

THIS COPY IS PROVIDED ON A RESTRICTED BASIS AND IS NOT TO BE USED IN ANY WAY DETRIMENTAL TO THE INTERESTS OF PANDUIT CORP.

CUSTOMER NAME	CUSTOMER APPROVAL	APPROVAL DATE
SEACOAST		
NORTHROP GRUMMAN		

PART NO.	MATERIAL	PACKAGE QUANTITY
MMP350HW54-MAL	5005 ALUMINUM	1000

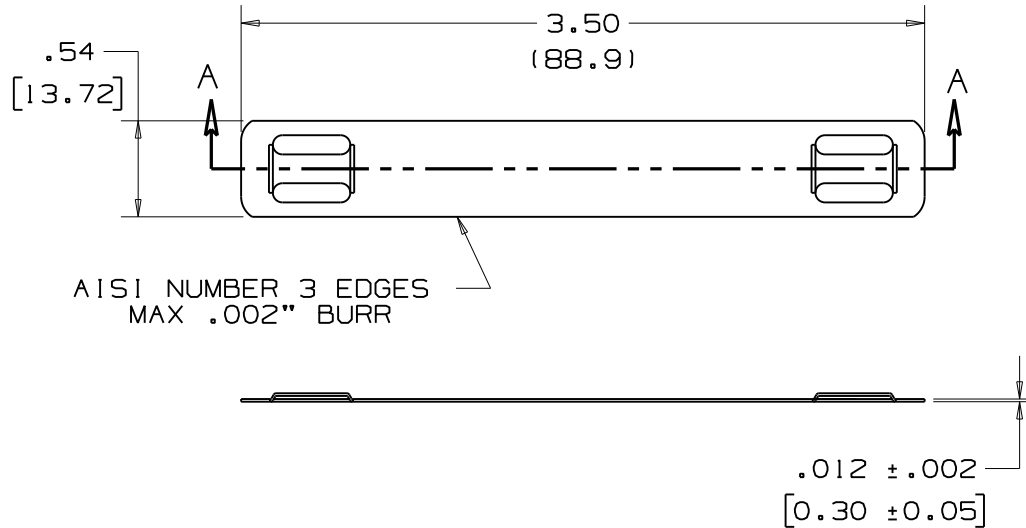

SECTION "A-A"

NOTES:

- BRACKETS [ ] DENOTES DIMENSIONS IN MILLIMETERS
- CUSTOM PERMANENT MARKING AVAILABLE. CONSULT FACTORY.
- TOLERANCE (UNLESS OTHERWISE SPECIFIED)  
 .xxx = ±.020 (.51)  
 .xx = ±.03 (.8)

S41288BS\_DC/02A

REV	DATE	BY	CHK	DESCRIPTION
02A	1/10	EJD	EJD	VOID DRAWING - REPLACED BY N41664BS_DC/00A
01A	12/09	EJD	EJD	ADDED CUSTOMER APPROVAL TABLE
00A	12/09	JAMB	EJD	DRAWING RELEASED

**PANDUIT**

CORP. TINLEY PARK, ILLINOIS

1/2" ALUMINUM MARKER PLATE-HEAVY  
CUSTOMER DRAWING

UNLESS OTHERWISE SPECIFIED,  
DIMENSIONAL TOLERANCES ARE:  
 (.X) ± (.XXX) ±  
 (.XX) ± ANGLES ±

UNLESS OTHERWISE SPECIFIED,  
ALL DIMENSIONS ARE GIVEN IN  
INCHES, THIRD ANGLE PROJECTION

DRAWN BY  
JAMB  
DATE  
12/10/09  
CHK'D  
EJD

MAT'L  
ALUMINUM

SCALE  
FULL & NOTED  
DRAWING NO.  
S41288BS\_DC  
DWG.  
A  
SIZE