

**PLEASE CHECK WWW.MOLEX.COM FOR LATEST PART INFORMATION**

**Part Number:** **0190190063**  
**Status:** **Active**  
**Overview:** Standard Quick-Disconnect Terminals  
**Description:** Avikrimp Quick Disconnect, Female, for 14-16 (2.00-1.30mm<sup>2</sup>) Wire, Mylar Tape, Tab 5.21 x 0.81mm

**Documents:**

<a href="#">3D Model</a>	<a href="#">Product Specification PS-19902-014-001 (PDF)</a>
<a href="#">3D Model (PDF)</a>	<a href="#">Product Specification PS-19902-015-001 (PDF)</a>
<a href="#">Drawing (PDF)</a>	<a href="#">RoHS Certificate of Compliance (PDF)</a>
<a href="#">Product Specification PS-19902-011-001 (PDF)</a>	

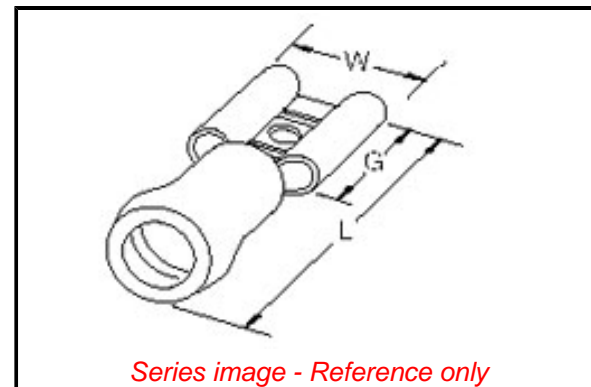

**General**

Product Family	Quick Disconnects
Series	19019
Crimp Quality Equipment	Yes
Insulated	Partial
Overview	Standard Quick-Disconnect Terminals
Product Name	Avikrimp
Taxonomy	Quick Disconnects
Type	Quick Disconnect
UPC	800755958508

**Physical**

Barrel Type	Closed
Color - Resin	Blue
Gender	Female
Glow-Wire Capable	No
Insulation	Nylon (PA)
Lock to Mating Part	None
Material - Metal	Brass
Material - Plating Mating	Tin
Material - Plating Termination	Tin
Net Weight	0.807/g
Orientation	Straight
Packaging Type	Adhesive Tape on Reel
Polarized to Mating Part	No
Tab Thickness	0.81mm
Tab Width	5.21mm
Temperature Range - Operating	-65° to +105°C
Wire Insulation Diameter	3.50mm max.
Wire Size AWG	14, 16
Wire Size mm <sup>2</sup>	1.30-2.00

**Electrical**

Voltage - Maximum	300V
-------------------	------

**Material Info**

Engineering Number	BB-8191-032T
--------------------	--------------

**Reference - Drawing Numbers**

Product Specification	PS-19902-011-001, PS-19902-014-001, PS-19902-015-001
Sales Drawing	SD-19019-001-001

**EU ELV**

**Not Relevant**

**EU RoHS**

**Not Reviewed**

**REACH SVHC**

Not Contained Per -  
ED/61/2018 (27 June  
2018)

**Halogen-Free**

**Status**

**Low-Halogen**

For more information, please visit [Contact US](#)

China ROHS

ELV

RoHS Phthalates

**China RoHS**

Green Image

Not Relevant

Not Contained

**Search Parts in this Series**

19019 Series

**Application Tooling | FAQ**

*Tooling specifications and manuals are found by selecting the products below. Crimp Height Specifications are then contained in the Application Tooling Specification document.*

**Global**

Description	Product #
ATP Crimp Dies for the Tape Crimp Module and ATP-101 & 301 Press	<a href="#">192880145</a>
Mini-Mac Applicator	<a href="#">638850900</a>

**PLEASE CHECK [WWW.MOLEX.COM](http://WWW.MOLEX.COM) FOR LATEST PART INFORMATION**