

TPA2035D1 Audio Power Amplifier Evaluation Module

The TPA2035D1 audio power amplifier evaluation module is a complete, low-power, Class-D, stereo audio power amplifier capable of delivering 2.75 W (YZF package). All components and the evaluation module are Pb-free. The evaluation module consists of a TPA2035D1 on the main circuit of the board. An additional TPA2035D1 Mini EVM is included.

Contents

1	Introduction	1
2	Operation	2
3	Reference	3
4	Related Documentation From Texas Instruments	6
5	EVM Board Revision History	6

List of Figures

1	TPA2035D1 Output Power	2
2	Top Layer	4
3	Bottom Layer	4
4	TPA2035D1EVM Schematic Diagram.....	5

List of Tables

1	TPA2035D1EVM Parts List.....	6
---	------------------------------	---

1 Introduction

This section provides an overview of the Texas Instruments (TI) TPA2035D1 NanoFree™ WCSP audio amplifier evaluation module (TPA2035D1EVM). It includes a brief description of the module and a list of EVM specifications.

1.1 TPA2035D1EVM Specifications

Supply voltage range, V_{DD}	2.5 V to 5.5 V
Power supply current rating required	2.5 A
Continuous output power, P_O : 4- Ω BTL, $V_{DD} = 5$ V	2.75 W
Audio input voltage, V_I	0 V to V_{DD}
Minimum load impedance, Z_L	4 Ω

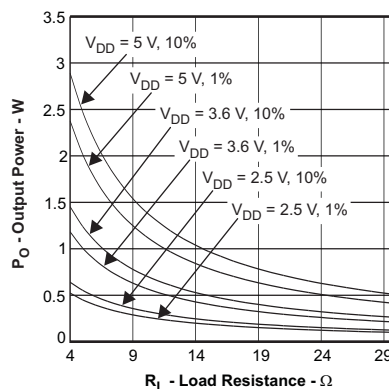

Figure 1. TPA2035D1 Output Power

2 Operation

This section describes how to operate the TPA2035D1EVM.

2.1 Quick Start for Stand-Alone Operation

Use the following steps when operating the TPA2035D1EVM stand-alone or when connecting the EVM into existing circuits or equipment.

2.1.1 Power and Ground

1. Ensure that the external power sources are set to OFF.
2. Set the power supply voltage between 2.5 V and 5.5 V. When connecting the power supply to the EVM, attach the ground connection to the GND header pin first, and then connect the positive supply to the VDD header pin. Verify that the connections are made to the correct header pins.

2.1.2 Inputs and Outputs

2.1.2.1 Audio

1. Ensure that the audio source is set to the minimum level.
2. Connect the audio source to the inputs, IN+/- .
 - For a differential audio source, connect the audio source directly to the appropriate input header pins.
 - For a single-ended audio source, connect the audio source to the negative input header pin and ground the positive audio input header pin.
3. Connect speakers (4 Ω-32 Ω) to the output pins, OUT+/- .

2.1.2.2 Shutdown Control

The TPA2035D1 provides a shutdown control so that the device can be placed into a shutdown mode. The shutdown pin, \overline{SD} , is an active low pin. This means that a low voltage (ground) on this pin places the device into a shutdown mode. Using the pushbutton provided on the EVM, the user can place the TPA2035D1 in shutdown mode by pressing and holding the button down. When the button is released, the device restarts.

2.2 Power Up

1. Verify the correct connections as described in Sections 2.1.1 and 2.1.2.
2. Verify the voltage setting of the power supply is between 2.5 V and 5.5 V, and turn on the power supply. Proper operation of the EVM begins.
3. Adjust the audio signal source as needed.

3 Reference

This section includes the EVM PCB layout reference, schematic, and parts list.

3.1 TPA2035D1EVM PCB Layers

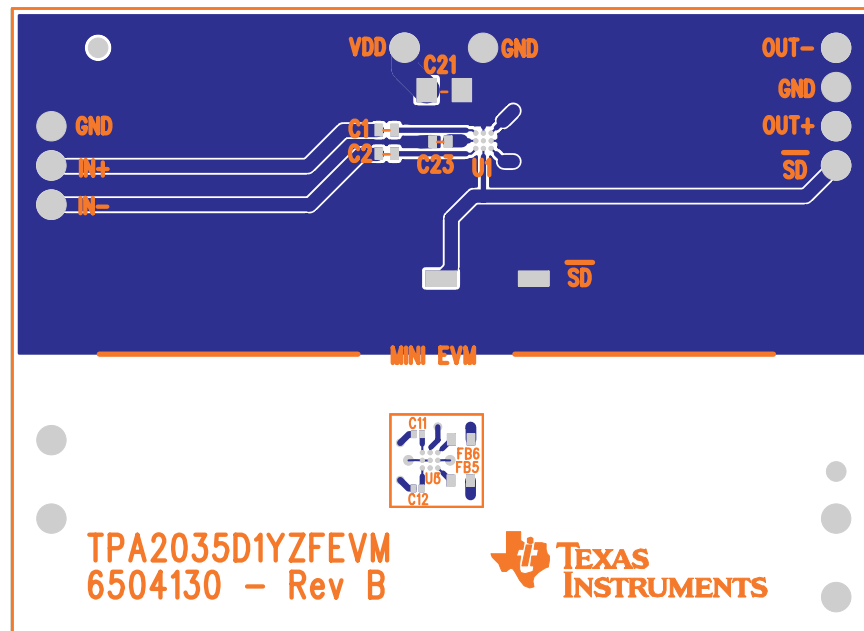

Figure 2. Top Layer

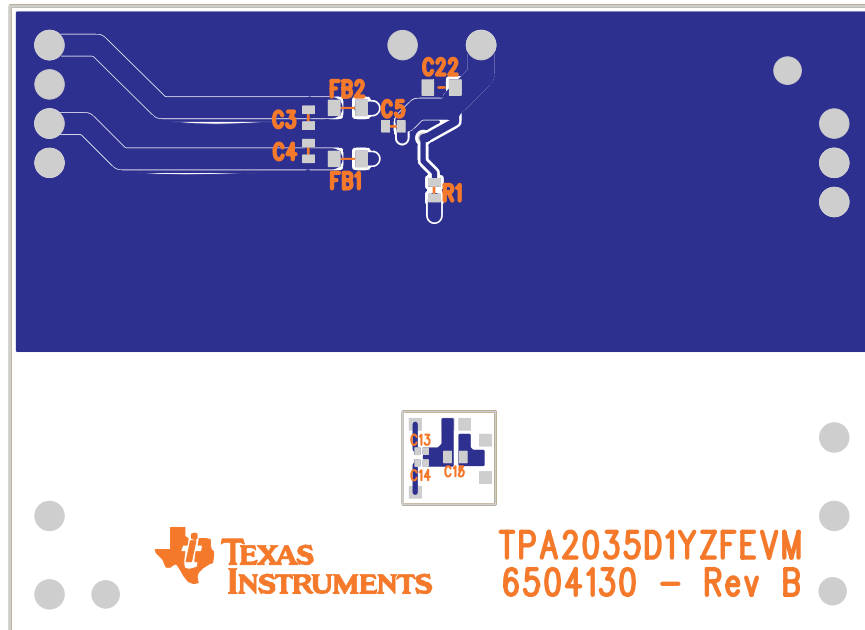
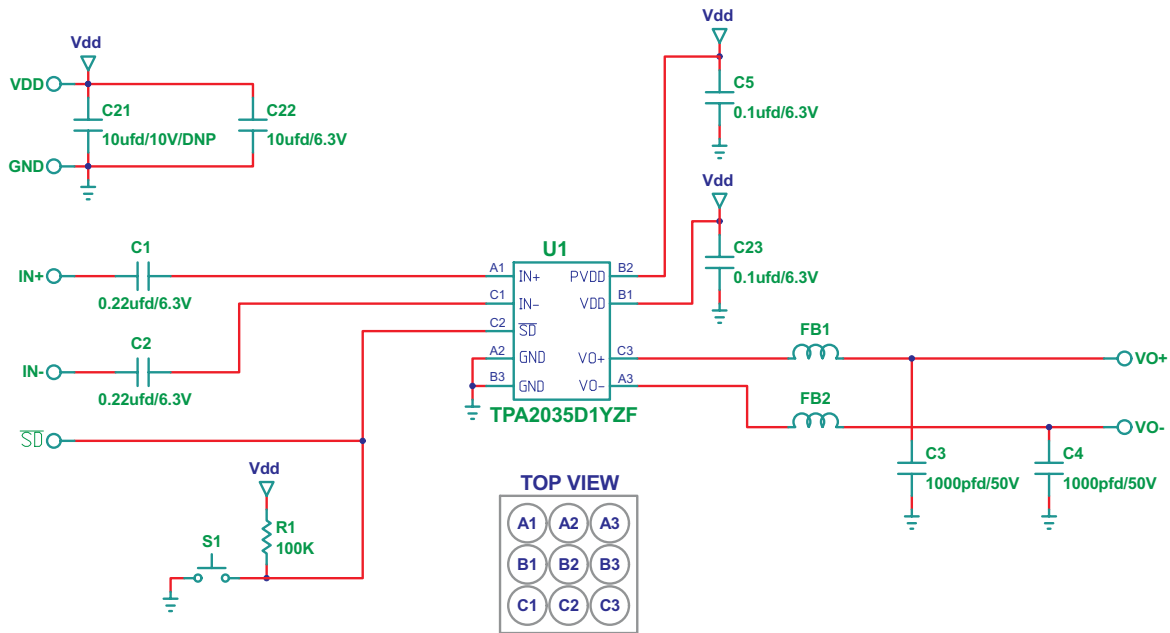

Figure 3. Bottom Layer

3.2 TPA2035D1EVM Schematic Diagram

TPA2035D1YZF EVALUATION MODULE (UPPER CIRCUIT)



MINI EVM (LOWER CIRCUIT)

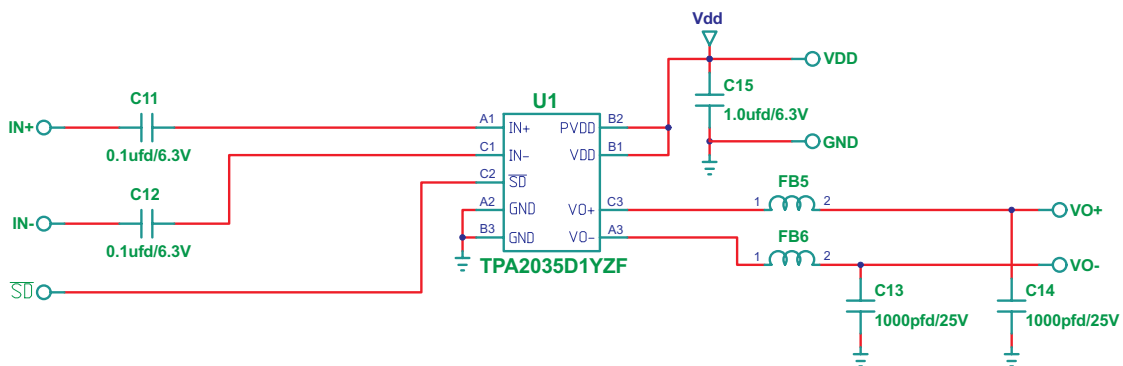

Figure 4. TPA2035D1EVM Schematic Diagram

3.3 TPA2035D1 Audio Power Amplifier Evaluation Module Parts List

Table 1. TPA2035D1EVM Parts List

Part No.	Description	Size	Qty.	Vendor Part Number
TPA2035D1 Main Circuit				
C1-2	Capacitor, Ceramic, 0.22uF, 6.3V, X5R	0402	2	TDK C1005X5R0J224
C5	Capacitor, Ceramic, 0.1uF, 6.3V, X5R	0402	1	TDK C1005X5R0J104
C3-4	Capacitor, Ceramic, 1nF, 50V, X7R	0402	2	TDK C1005X7R1H102
C22	Capacitor, Ceramic, 10uF, 6.3V, X5R	0603	1	TDK C1608X5R0J106
C21	Capacitor, Ceramic, 10uF, 10V	0805	1	Not Assembled
C23	Capacitor, Ceramic, 0.1uF, 6.3V, X5R	0402	1	TDK C1005X5R0J104
R1	Resistor, Chip, 100K, 1/16W, 1%	0402	1	Panasonic, ERJ-2RKF1003X
U1	TPA2035D1 audio amplifier IC 1.5 X 1.5 mm WCSP		1	Texas Instruments, TPA2035D1YZF
FB1-2	Ferrite Bead	0603	4	TDK MPZ1608S221A
	Terminal post headers		12	Sullins, PTC36SABN, SAMTEC TSW-19-8-G-S"
S1	Switch, momentary	SMT	1	Panasonic, EVQ-PPBA25
PCB	TPA2035D1EVM printed circuit board		1	
TPA2035D1 Mini Circuit				
C11-12	Capacitor, Ceramic, 0.1uF, 6.3V, X5R	0201	2	TDK C0603X5R0J104
C13-14	Capacitor, Ceramic, 1nF, 25V, X5R	0201	2	TDK C0603X5R1E102
C15	Capacitor, Ceramic, 1uF, 6.3V, X5R	0402	1	TDK C1005X5R0J105
U3	TPA2035D1 audio amplifier IC 1.5 X 1.5 mm WCSP		1	Texas Instruments, TPA2035D1YZF
FB5-6	Ferrite Bead	0402	2	TDK MPZ1005S121C

4 Related Documentation From Texas Instruments

- *TPA2035D1 2.75-W Fixed Gain Mono Filter-Free Class-D Audio Power Amplifier* ([SLOS562](#)) This is the data sheet for the TPA2035D1 audio amplifier integrated circuit.

5 EVM Board Revision History

This is a list of modification made to the TPA2035D1EVM board Rev. A and appearing on Rev. B. The modifications do not affect the performance of the board.

Modification	Date	Description
EVM Label	12/2009	Changed from TPA2035D1 to TPA2035D1YZF (added package label)
GND	12/2009	Added ground label to right side of standard EVM silkscreen
Revision	12/2009	Updated EVM revision letter on silkscreen
TI Logo	12/2009	Moved TI logo on silkscreen.

EVALUATION BOARD/KIT IMPORTANT NOTICE

Texas Instruments (TI) provides the enclosed product(s) under the following conditions:

This evaluation board/kit is intended for use for **ENGINEERING DEVELOPMENT, DEMONSTRATION, OR EVALUATION PURPOSES ONLY** and is not considered by TI to be a finished end-product fit for general consumer use. Persons handling the product(s) must have electronics training and observe good engineering practice standards. As such, the goods being provided are not intended to be complete in terms of required design-, marketing-, and/or manufacturing-related protective considerations, including product safety and environmental measures typically found in end products that incorporate such semiconductor components or circuit boards. This evaluation board/kit does not fall within the scope of the European Union directives regarding electromagnetic compatibility, restricted substances (RoHS), recycling (WEEE), FCC, CE or UL, and therefore may not meet the technical requirements of these directives or other related directives.

Should this evaluation board/kit not meet the specifications indicated in the User's Guide, the board/kit may be returned within 30 days from the date of delivery for a full refund. **THE FOREGOING WARRANTY IS THE EXCLUSIVE WARRANTY MADE BY SELLER TO BUYER AND IS IN LIEU OF ALL OTHER WARRANTIES, EXPRESSED, IMPLIED, OR STATUTORY, INCLUDING ANY WARRANTY OF MERCHANTABILITY OR FITNESS FOR ANY PARTICULAR PURPOSE.**

The user assumes all responsibility and liability for proper and safe handling of the goods. Further, the user indemnifies TI from all claims arising from the handling or use of the goods. Due to the open construction of the product, it is the user's responsibility to take any and all appropriate precautions with regard to electrostatic discharge.

EXCEPT TO THE EXTENT OF THE INDEMNITY SET FORTH ABOVE, NEITHER PARTY SHALL BE LIABLE TO THE OTHER FOR ANY INDIRECT, SPECIAL, INCIDENTAL, OR CONSEQUENTIAL DAMAGES.

TI currently deals with a variety of customers for products, and therefore our arrangement with the user **is not exclusive.**

TI assumes **no liability for applications assistance, customer product design, software performance, or infringement of patents or services described herein.**

Please read the User's Guide and, specifically, the Warnings and Restrictions notice in the User's Guide prior to handling the product. This notice contains important safety information about temperatures and voltages. For additional information on TI's environmental and/or safety programs, please contact the TI application engineer or visit www.ti.com/esh.

No license is granted under any patent right or other intellectual property right of TI covering or relating to any machine, process, or combination in which such TI products or services might be or are used.

FCC Warning

This evaluation board/kit is intended for use for **ENGINEERING DEVELOPMENT, DEMONSTRATION, OR EVALUATION PURPOSES ONLY** and is not considered by TI to be a finished end-product fit for general consumer use. It generates, uses, and can radiate radio frequency energy and has not been tested for compliance with the limits of computing devices pursuant to part 15 of FCC rules, which are designed to provide reasonable protection against radio frequency interference. Operation of this equipment in other environments may cause interference with radio communications, in which case the user at his own expense will be required to take whatever measures may be required to correct this interference.

EVM WARNINGS AND RESTRICTIONS

It is important to operate this EVM within the input voltage range of 2.5 V to 5 V and the output voltage range of 0 V to 5.5 V.

Exceeding the specified input range may cause unexpected operation and/or irreversible damage to the EVM. If there are questions concerning the input range, please contact a TI field representative prior to connecting the input power.

Applying loads outside of the specified output range may result in unintended operation and/or possible permanent damage to the EVM. Please consult the EVM User's Guide prior to connecting any load to the EVM output. If there is uncertainty as to the load specification, please contact a TI field representative.

During normal operation, some circuit components may have case temperatures greater than 60°C. The EVM is designed to operate properly with certain components above 60°C as long as the input and output ranges are maintained. These components include but are not limited to linear regulators, switching transistors, pass transistors, and current sense resistors. These types of devices can be identified using the EVM schematic located in the EVM User's Guide. When placing measurement probes near these devices during operation, please be aware that these devices may be very warm to the touch.

Mailing Address: Texas Instruments, Post Office Box 655303, Dallas, Texas 75265
Copyright © 2008-2009, Texas Instruments Incorporated

IMPORTANT NOTICE

Texas Instruments Incorporated and its subsidiaries (TI) reserve the right to make corrections, modifications, enhancements, improvements, and other changes to its products and services at any time and to discontinue any product or service without notice. Customers should obtain the latest relevant information before placing orders and should verify that such information is current and complete. All products are sold subject to TI's terms and conditions of sale supplied at the time of order acknowledgment.

TI warrants performance of its hardware products to the specifications applicable at the time of sale in accordance with TI's standard warranty. Testing and other quality control techniques are used to the extent TI deems necessary to support this warranty. Except where mandated by government requirements, testing of all parameters of each product is not necessarily performed.

TI assumes no liability for applications assistance or customer product design. Customers are responsible for their products and applications using TI components. To minimize the risks associated with customer products and applications, customers should provide adequate design and operating safeguards.

TI does not warrant or represent that any license, either express or implied, is granted under any TI patent right, copyright, mask work right, or other TI intellectual property right relating to any combination, machine, or process in which TI products or services are used. Information published by TI regarding third-party products or services does not constitute a license from TI to use such products or services or a warranty or endorsement thereof. Use of such information may require a license from a third party under the patents or other intellectual property of the third party, or a license from TI under the patents or other intellectual property of TI.

Reproduction of TI information in TI data books or data sheets is permissible only if reproduction is without alteration and is accompanied by all associated warranties, conditions, limitations, and notices. Reproduction of this information with alteration is an unfair and deceptive business practice. TI is not responsible or liable for such altered documentation. Information of third parties may be subject to additional restrictions.

Resale of TI products or services with statements different from or beyond the parameters stated by TI for that product or service voids all express and any implied warranties for the associated TI product or service and is an unfair and deceptive business practice. TI is not responsible or liable for any such statements.

TI products are not authorized for use in safety-critical applications (such as life support) where a failure of the TI product would reasonably be expected to cause severe personal injury or death, unless officers of the parties have executed an agreement specifically governing such use. Buyers represent that they have all necessary expertise in the safety and regulatory ramifications of their applications, and acknowledge and agree that they are solely responsible for all legal, regulatory and safety-related requirements concerning their products and any use of TI products in such safety-critical applications, notwithstanding any applications-related information or support that may be provided by TI. Further, Buyers must fully indemnify TI and its representatives against any damages arising out of the use of TI products in such safety-critical applications.

TI products are neither designed nor intended for use in military/aerospace applications or environments unless the TI products are specifically designated by TI as military-grade or "enhanced plastic." Only products designated by TI as military-grade meet military specifications. Buyers acknowledge and agree that any such use of TI products which TI has not designated as military-grade is solely at the Buyer's risk, and that they are solely responsible for compliance with all legal and regulatory requirements in connection with such use.

TI products are neither designed nor intended for use in automotive applications or environments unless the specific TI products are designated by TI as compliant with ISO/TS 16949 requirements. Buyers acknowledge and agree that, if they use any non-designated products in automotive applications, TI will not be responsible for any failure to meet such requirements.

Following are URLs where you can obtain information on other Texas Instruments products and application solutions:

Products

Amplifiers	amplifier.ti.com
Data Converters	dataconverter.ti.com
DLP® Products	www.dlp.com
DSP	dsp.ti.com
Clocks and Timers	www.ti.com/clocks
Interface	interface.ti.com
Logic	logic.ti.com
Power Mgmt	power.ti.com
Microcontrollers	microcontroller.ti.com
RFID	www.ti-rfid.com
RF/IF and ZigBee® Solutions	www.ti.com/lprf

Applications

Audio	www.ti.com/audio
Automotive	www.ti.com/automotive
Broadband	www.ti.com/broadband
Digital Control	www.ti.com/digitalcontrol
Medical	www.ti.com/medical
Military	www.ti.com/military
Optical Networking	www.ti.com/opticalnetwork
Security	www.ti.com/security
Telephony	www.ti.com/telephony
Video & Imaging	www.ti.com/video
Wireless	www.ti.com/wireless

Mailing Address: Texas Instruments, Post Office Box 655303, Dallas, Texas 75265
Copyright © 2009, Texas Instruments Incorporated