

To our customers,

Old Company Name in Catalogs and Other Documents

On April 1st, 2010, NEC Electronics Corporation merged with Renesas Technology Corporation, and Renesas Electronics Corporation took over all the business of both companies. Therefore, although the old company name remains in this document, it is a valid Renesas Electronics document. We appreciate your understanding.

Renesas Electronics website: <http://www.renesas.com>

April 1st, 2010
Renesas Electronics Corporation

Issued by: Renesas Electronics Corporation (<http://www.renesas.com>)

Send any inquiries to <http://www.renesas.com/inquiry>.

Notice

1. All information included in this document is current as of the date this document is issued. Such information, however, is subject to change without any prior notice. Before purchasing or using any Renesas Electronics products listed herein, please confirm the latest product information with a Renesas Electronics sales office. Also, please pay regular and careful attention to additional and different information to be disclosed by Renesas Electronics such as that disclosed through our website.
2. Renesas Electronics does not assume any liability for infringement of patents, copyrights, or other intellectual property rights of third parties by or arising from the use of Renesas Electronics products or technical information described in this document. No license, express, implied or otherwise, is granted hereby under any patents, copyrights or other intellectual property rights of Renesas Electronics or others.
3. You should not alter, modify, copy, or otherwise misappropriate any Renesas Electronics product, whether in whole or in part.
4. Descriptions of circuits, software and other related information in this document are provided only to illustrate the operation of semiconductor products and application examples. You are fully responsible for the incorporation of these circuits, software, and information in the design of your equipment. Renesas Electronics assumes no responsibility for any losses incurred by you or third parties arising from the use of these circuits, software, or information.
5. When exporting the products or technology described in this document, you should comply with the applicable export control laws and regulations and follow the procedures required by such laws and regulations. You should not use Renesas Electronics products or the technology described in this document for any purpose relating to military applications or use by the military, including but not limited to the development of weapons of mass destruction. Renesas Electronics products and technology may not be used for or incorporated into any products or systems whose manufacture, use, or sale is prohibited under any applicable domestic or foreign laws or regulations.
6. Renesas Electronics has used reasonable care in preparing the information included in this document, but Renesas Electronics does not warrant that such information is error free. Renesas Electronics assumes no liability whatsoever for any damages incurred by you resulting from errors in or omissions from the information included herein.
7. Renesas Electronics products are classified according to the following three quality grades: "Standard", "High Quality", and "Specific". The recommended applications for each Renesas Electronics product depends on the product's quality grade, as indicated below. You must check the quality grade of each Renesas Electronics product before using it in a particular application. You may not use any Renesas Electronics product for any application categorized as "Specific" without the prior written consent of Renesas Electronics. Further, you may not use any Renesas Electronics product for any application for which it is not intended without the prior written consent of Renesas Electronics. Renesas Electronics shall not be in any way liable for any damages or losses incurred by you or third parties arising from the use of any Renesas Electronics product for an application categorized as "Specific" or for which the product is not intended where you have failed to obtain the prior written consent of Renesas Electronics. The quality grade of each Renesas Electronics product is "Standard" unless otherwise expressly specified in a Renesas Electronics data sheets or data books, etc.

"Standard": Computers; office equipment; communications equipment; test and measurement equipment; audio and visual equipment; home electronic appliances; machine tools; personal electronic equipment; and industrial robots.

"High Quality": Transportation equipment (automobiles, trains, ships, etc.); traffic control systems; anti-disaster systems; anti-crime systems; safety equipment; and medical equipment not specifically designed for life support.

"Specific": Aircraft; aerospace equipment; submersible repeaters; nuclear reactor control systems; medical equipment or systems for life support (e.g. artificial life support devices or systems), surgical implantations, or healthcare intervention (e.g. excision, etc.), and any other applications or purposes that pose a direct threat to human life.

8. You should use the Renesas Electronics products described in this document within the range specified by Renesas Electronics, especially with respect to the maximum rating, operating supply voltage range, movement power voltage range, heat radiation characteristics, installation and other product characteristics. Renesas Electronics shall have no liability for malfunctions or damages arising out of the use of Renesas Electronics products beyond such specified ranges.
9. Although Renesas Electronics endeavors to improve the quality and reliability of its products, semiconductor products have specific characteristics such as the occurrence of failure at a certain rate and malfunctions under certain use conditions. Further, Renesas Electronics products are not subject to radiation resistance design. Please be sure to implement safety measures to guard them against the possibility of physical injury, and injury or damage caused by fire in the event of the failure of a Renesas Electronics product, such as safety design for hardware and software including but not limited to redundancy, fire control and malfunction prevention, appropriate treatment for aging degradation or any other appropriate measures. Because the evaluation of microcomputer software alone is very difficult, please evaluate the safety of the final products or system manufactured by you.
10. Please contact a Renesas Electronics sales office for details as to environmental matters such as the environmental compatibility of each Renesas Electronics product. Please use Renesas Electronics products in compliance with all applicable laws and regulations that regulate the inclusion or use of controlled substances, including without limitation, the EU RoHS Directive. Renesas Electronics assumes no liability for damages or losses occurring as a result of your noncompliance with applicable laws and regulations.
11. This document may not be reproduced or duplicated, in any form, in whole or in part, without prior written consent of Renesas Electronics.
12. Please contact a Renesas Electronics sales office if you have any questions regarding the information contained in this document or Renesas Electronics products, or if you have any other inquiries.

(Note 1) "Renesas Electronics" as used in this document means Renesas Electronics Corporation and also includes its majority-owned subsidiaries.

(Note 2) "Renesas Electronics product(s)" means any product developed or manufactured by or for Renesas Electronics.

The revision list can be viewed directly by clicking the title page.

The revision list summarizes the locations of revisions and additions. Details should always be checked by referring to the relevant text.

H8/3048B Group

Hardware Manual

Renesas 8-Bit Single-Chip Microcomputer H8 Family/H8/300H Series

H8/3048B	HD6433048B
	HD6433048BV
H8/3048F-ONE	HD64F3048B
	HD64F3048BV

Keep safety first in your circuit designs!

1. Renesas Technology Corp. puts the maximum effort into making semiconductor products better and more reliable, but there is always the possibility that trouble may occur with them. Trouble with semiconductors may lead to personal injury, fire or property damage.
Remember to give due consideration to safety when making your circuit designs, with appropriate measures such as (i) placement of substitutive, auxiliary circuits, (ii) use of nonflammable material or (iii) prevention against any malfunction or mishap.

Notes regarding these materials

1. These materials are intended as a reference to assist our customers in the selection of the Renesas Technology Corp. product best suited to the customer's application; they do not convey any license under any intellectual property rights, or any other rights, belonging to Renesas Technology Corp. or a third party.
2. Renesas Technology Corp. assumes no responsibility for any damage, or infringement of any third-party's rights, originating in the use of any product data, diagrams, charts, programs, algorithms, or circuit application examples contained in these materials.
3. All information contained in these materials, including product data, diagrams, charts, programs and algorithms represents information on products at the time of publication of these materials, and are subject to change by Renesas Technology Corp. without notice due to product improvements or other reasons. It is therefore recommended that customers contact Renesas Technology Corp. or an authorized Renesas Technology Corp. product distributor for the latest product information before purchasing a product listed herein.
The information described here may contain technical inaccuracies or typographical errors.
Renesas Technology Corp. assumes no responsibility for any damage, liability, or other loss rising from these inaccuracies or errors.
Please also pay attention to information published by Renesas Technology Corp. by various means, including the Renesas Technology Corp. Semiconductor home page (<http://www.renesas.com>).
4. When using any or all of the information contained in these materials, including product data, diagrams, charts, programs, and algorithms, please be sure to evaluate all information as a total system before making a final decision on the applicability of the information and products. Renesas Technology Corp. assumes no responsibility for any damage, liability or other loss resulting from the information contained herein.
5. Renesas Technology Corp. semiconductors are not designed or manufactured for use in a device or system that is used under circumstances in which human life is potentially at stake. Please contact Renesas Technology Corp. or an authorized Renesas Technology Corp. product distributor when considering the use of a product contained herein for any specific purposes, such as apparatus or systems for transportation, vehicular, medical, aerospace, nuclear, or undersea repeater use.
6. The prior written approval of Renesas Technology Corp. is necessary to reprint or reproduce in whole or in part these materials.
7. If these products or technologies are subject to the Japanese export control restrictions, they must be exported under a license from the Japanese government and cannot be imported into a country other than the approved destination.
Any diversion or reexport contrary to the export control laws and regulations of Japan and/or the country of destination is prohibited.
8. Please contact Renesas Technology Corp. for further details on these materials or the products contained therein.

General Precautions on Handling of Product

1. Treatment of NC Pins

Note: Do not connect anything to the NC pins.

The NC (not connected) pins are either not connected to any of the internal circuitry or are used as test pins or to reduce noise. If something is connected to the NC pins, the operation of the LSI is not guaranteed.

2. Treatment of Unused Input Pins

Note: Fix all unused input pins to high or low level.

Generally, the input pins of CMOS products are high-impedance input pins. If unused pins are in their open states, intermediate levels are induced by noise in the vicinity, a pass-through current flows internally, and a malfunction may occur.

3. Processing before Initialization

Note: When power is first supplied, the product's state is undefined.

The states of internal circuits are undefined until full power is supplied throughout the chip and a low level is input on the reset pin. During the period where the states are undefined, the register settings and the output state of each pin are also undefined. Design your system so that it does not malfunction because of processing while it is in this undefined state. For those products which have a reset function, reset the LSI immediately after the power supply has been turned on.

4. Prohibition of Access to Undefined or Reserved Addresses

Note: Access to undefined or reserved addresses is prohibited.

The undefined or reserved addresses may be used to expand functions, or test registers may have been allocated to these addresses. Do not access these registers; the system's operation is not guaranteed if they are accessed.

Preface

The H8/3048B Group is a series of high-performance microcontrollers that integrate system supporting functions together with an H8/300H CPU core. In addition, the H8/3048F-ONE is equipped with an on-chip emulator (E10T)^{*2}.

The H8/300H CPU has a 32-bit internal architecture with sixteen 16-bit general registers, and a concise, optimized instruction set designed for speed. It can address a 16-Mbyte linear address space.

The on-chip emulator (E10T)^{*2} has functions that allow it to emulate directly a microcontroller mounted on the user board. This makes possible on-board program debugging.

The on-chip supporting functions include ROM, RAM, a 16-bit integrated timer unit (ITU), a programmable timing pattern controller (TPC), a watchdog timer (WDT), a serial communication interface (SCI), an A/D converter, a D/A converter, I/O ports, a direct memory access controller (DMAC), a refresh controller, and other facilities. Of the two SCI channels, one has been expanded to support the ISO/IEC7816-3 smart card interface. Functions have also been added to reduce power consumption in battery-powered applications: individual modules can be placed in standby, and the frequency of the system clock supplied to the chip can be divided down under software control.

The address space is divided into eight areas. The data bus width and access cycle length can be selected independently in each area, simplifying the connection of different types of memory. Seven operating modes (modes 1 to 7) are provided, offering a choice of data bus width and address space size.

With these features, the H8/3048B Group can be used to implement compact, high-performance systems easily.

Versions with either flash memory (F-ZTAT^{TM*1}) or mask ROM as the on-chip ROM are available. This enables users to respond quickly and flexibly to changing application specifications from the initial production stage through full-scale volume production.

This manual describes the H8/3048B Group hardware. For information on H8/3048 Group products, please refer to the H8/3048 Group Hardware Manual. For details of the instruction set, refer to the H8/300H Series Programming Manual.

- Notes:
1. F-ZTAT (Flexible ZTAT) is a trademark of Renesas Technology Corp.
 2. An on-chip emulator (E10T) is not provided in the mask ROM version.

Notes on using the on-chip emulator (E10T) installed in the H8/3048F-ONE

H8/3048 Group products and H8/3048B Group products have different specifications regarding the pin arrangement (pin 1, VCL), flash memory, and maximum operating frequency. Refer to Comparison of H8/3048 Group Product Specifications for details of these differences.

Notes:

When using an on-chip emulator (E10T) for H8/3048 program development and debugging, the following restrictions must be noted.

1. Only programs in the on-chip flash memory can be developed and debugged. Consequently, emulation is not possible for programs in external memory or in the no-ROM mode.
2. Refresh controller and DMAC operation are not supported, so settings should not be made to the registers for these modules.
3. During break mode of on-chip emulation, the watchdog timer stops counting. Accordingly, the counter value may be invalid after resuming from the break mode.
4. The FWE (BRK) pin and pins P91, P93, and P95 are reserved for the E10T, and cannot be used.
5. Area H'F7000 to H'F7FFF in 1-M address mode (area H'FF7000 to H'FF77FF in 16-M address mode) is used by the E10T, and is not available to the user.
6. The initial program instructions following a reset should be initialize stack pointer (SP) and read mode register (MDCR). (After initializing SP using the MOV.L instruction, use the MOV.B instruction to read the MDCR register.)
7. Emulation of the hardware standby mode is not supported.

Comparison of H8/3048 Group Product Specifications

There are eight members of the H8/3048 Group; the H8/3048F-ZTAT (H8/3048F*¹, H8/3048F-ONE*²), H8/3048ZTAT, H8/3048 mask ROM version, H8/3048B mask ROM version, H8/3047 mask ROM version, H8/3045 mask ROM version, and H8/3044 mask ROM version.

The specifications of each model is compared below.





Notes: 1. H8/3048F has dual power supply with flash memory installed.

2. H8/3048F-ONE has single power supply with flash memory and E10T installed.

Hardware Manual	H8/3048 Group (Rev. 7.0)			H8/3048B Group (Rev. 3.0)	
	ZTAT	Mask ROM	F-ZTAT		Mask ROM
ROM Type	H8/3048	H8/3048 mask ROM version H8/3047 mask ROM version H8/3045 mask ROM version H8/3044 mask ROM version	H8/3048F	H8/3048F-ONE	H8/3048B mask ROM version
Model Type	PROM model	Mask ROM model	Dual power supply, flash memory is installed	Single power supply, flash memory installed, internal step-down (5 V operation model), high-speed operation model	Mask ROM model
Model Spec			Refer to 1.4, Differences between H8/3048F and H8/3048F-ONE.	Refer to 1.4.3, Differences between H8/3048F and H8/3048F-ONE.	
Model Type No.	HD6473048	HD6433048 HD6433047 HD6433045 HD6433044	HD64F3048	HD64F3048B (5 V operation model) HD64F3048BV (3 V operation model)	HD6433048B (5 V operation model) HD6433048BV (3 V operation model)
Pin Assignment	Refer to figure 1.2, Pin Arrangement of H8/3048ZTAT, H8/3048 Mask ROM Version, H8/3047 Mask ROM Version, H8/3045 Mask ROM Version, H8/3044 Mask ROM Version, and H8/3048F (FP-100B or TFP-100B, Top View), in section 1.			5-V operation models have a V_{cc} pin and an external capacitor must be connected. Refer to figure 1.3, H8/3048F-ONE Pin Arrangement (FP-100B or TFP-100B, Top View), in section 1.	

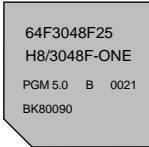
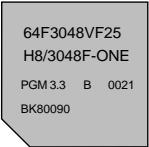
Hardware Manual	H8/3048 Group (Rev. 7.0)			H8/3048B Group (Rev. 3.0)	
ROM Type	ZTAT	Mask ROM	F-ZTAT		Mask ROM
RAM Capacity	4 kbytes	H8/3048: 4 kbytes H8/3047: 4 kbytes H8/3045: 2 kbytes H8/3044: 2 kbytes	4 kbytes	4 kbytes	
ROM Capacity	128 kbytes	H8/3048: 128 kbytes H8/3047: 96 kbytes H8/3045: 64 kbytes H8/3044: 32 kbytes	128 kbytes	128 kbytes	
Flash Memory	—	—	Refer to section 19, Flash Memory (H8/3048F Dual Power Supply).	Refer to section 18, ROM (H8/3048F-ONE: Single Power Supply, H8/3048B Mask ROM Version)	—
Clock Pulse Generator	Refer to section 20, Clock Pulse Generator.			Refer to section 19, Clock Pulse Generator.	
Power-Down State	Refer to section 21, Power-Down State.			Refer to section 20, Power-Down State.	
	Clock oscillator settling time: Waiting time of up to 131072 states			Clock oscillator settling time: Waiting time of up to 262144 states	
Electrical Characteristics (Clock Rate)	Refer to table 22.1, Electrical Characteristics of H8/3048 Group Products, in section 22.			Refer to table 21.1, Electrical Characteristics of H8/3048 Group and H8/3048B Group Products, in section 21.	
	1 to 18 MHz		1 to 16 MHz	5 V operation models: 2 to 25 MHz, 3 V operation models: 2 to 25 MHz.	
List of Registers	Refer to table B.1, Comparison of H8/3048 Group Internal I/O Register Specifications, in appendix B.				
	Refer to appendix B.1, Addresses.				
Notes on Usage	—	—	—	Refer to section 1.4, Notes on H8/3048F-ONE (Single Power Supply)	—
On-chip Emulator (E10T)	—	—	—	On-chip emulator (E10T)	—

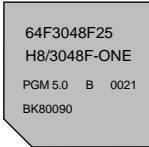
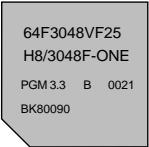
Main Revisions for This Edition

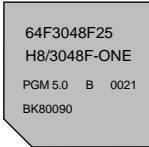
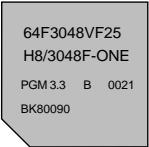
Item	Page	Revision (See Manual for Details)																				
All	—	<ul style="list-style-type: none"> Notification of change in company name amended (Before) Hitachi, Ltd. → (After) Renesas Technology Corp. Product naming convention amended (Before) H8/3048B Series → (After) H8/3048B Group 																				
1.3.1 Pin Arrangement Figure 1.3 H8/3048B Group Pin Arrangement (FP-100B or TFP-100B, Top View)	8	<p>Note amended</p> <p>Note: 1. For the 5 V operation product, this pin is used as the V_{CL} terminal, and for the 3 V operation models, this pin is used as the V_{CC} terminal that requires an external capacitor.</p>																				
1.3.3 Pin Functions Table 1.4 Pin Functions	18, 19	<p>Table amended</p> <table border="1"> <thead> <tr> <th>Type</th> <th>Symbol</th> <th>Pin No.</th> <th>I/O</th> <th>Name and Function</th> </tr> </thead> <tbody> <tr> <td>A/D and D/A converters</td> <td>AV_{CC}</td> <td>76</td> <td>Input</td> <td>Power supply pin for the A/D and D/A converters. Connect to the system power supply (V_{CC}) when not using the A/D and D/A converters.</td> </tr> <tr> <td></td> <td>AV_{SS}</td> <td>86</td> <td>Input</td> <td>Ground pin for the A/D and D/A converters. Connect to system ground (V_{SS}).</td> </tr> <tr> <td></td> <td>V_{REF}</td> <td>77</td> <td>Input</td> <td>Reference voltage input pin for the A/D and D/A converters. Connect to the system power supply (V_{CC}) when not using the A/D and D/A converters.</td> </tr> </tbody> </table>	Type	Symbol	Pin No.	I/O	Name and Function	A/D and D/A converters	AV_{CC}	76	Input	Power supply pin for the A/D and D/A converters. Connect to the system power supply (V_{CC}) when not using the A/D and D/A converters.		AV_{SS}	86	Input	Ground pin for the A/D and D/A converters. Connect to system ground (V_{SS}).		V_{REF}	77	Input	Reference voltage input pin for the A/D and D/A converters. Connect to the system power supply (V_{CC}) when not using the A/D and D/A converters.
Type	Symbol	Pin No.	I/O	Name and Function																		
A/D and D/A converters	AV_{CC}	76	Input	Power supply pin for the A/D and D/A converters. Connect to the system power supply (V_{CC}) when not using the A/D and D/A converters.																		
	AV_{SS}	86	Input	Ground pin for the A/D and D/A converters. Connect to system ground (V_{SS}).																		
	V_{REF}	77	Input	Reference voltage input pin for the A/D and D/A converters. Connect to the system power supply (V_{CC}) when not using the A/D and D/A converters.																		
1.4.2 Product Type Names and Markings Table 1.5 Differences in H8/3048F and H8/3048F-ONE	21	<p>Sample markings amended</p> <table border="1"> <thead> <tr> <th></th> <th>Dual Power Supply Model: H8/3048F</th> <th colspan="2">Single Power Supply Model: H8/3048F-ONE</th> </tr> </thead> <tbody> <tr> <td>Sample markings</td> <td>  </td> <td>  </td> <td>  </td> </tr> </tbody> </table>		Dual Power Supply Model: H8/3048F	Single Power Supply Model: H8/3048F-ONE		Sample markings															
	Dual Power Supply Model: H8/3048F	Single Power Supply Model: H8/3048F-ONE																				
Sample markings																						

5.5.4 Usage Notes on 120
External Interrupts

Figure 5.9 IRQnF Flag When Interrupt Processing Is Not Conducted

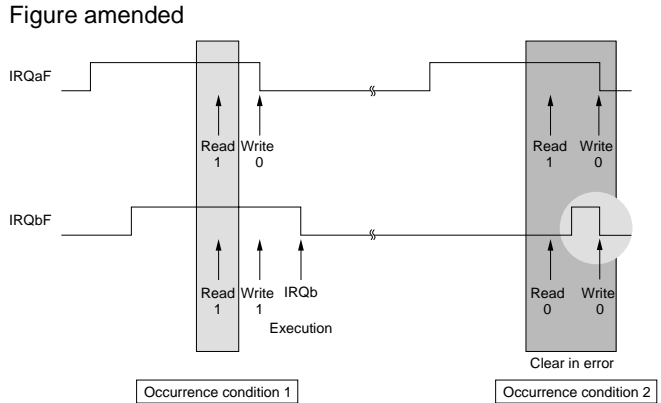

10.2.3 Timer Mode 335
Register (TMDR)

Bit 6—Phase Counting Mode Flag (MDF)

Table amended

Counting Direction	Down-Counting				Up-Counting				
	TCLKA pin	↑	High	↓	Low	↑	Low	↓	High
TCLKB pin	Low	↑	High	↓	High	↑	Low	↓	High

13.2.8 Bit Rate 473,
Register (BRR) 475

Table 13.3 Examples of Bit Rates and BRR Settings in Asynchronous Mode

Table amended

Bit Rate (bits/s)	ϕ (MHz)								
	3			3.6864			25		
	n	N	Error (%)	n	N	Error (%)	n	N	Error (%)
110	1	212	0.03	2	64	0.70	3	110	-0.02
150	1	155	0.16	1	191	0.00	3	80	0.47
300	1	77	0.16	1	95	0.00	2	162	-0.15
600	0	155	0.16	0	191	0.00	2	80	0.47
1200	0	77	0.16	0	95	0.00	1	162	-0.15
2400	0	38	0.16	0	47	0.00	1	80	0.47
4800	0	19	-2.34	0	23	0.00	0	162	-0.15
9600	0	9	-2.34	0	11	0.00	0	80	0.47
19200	0	4	-2.34	0	5	0.00	0	40	-0.76
31250	0	2	0.00	0	3	-7.84	0	24	0.00
38400	0	1	22.07	0	2	0.00	0	19	1.73

13.3.2 Operation in 492
Asynchronous Mode

Figure 13.8 Example of SCI Receive Operation (8-Bit Data with Parity and One Stop Bit)

Figure amended

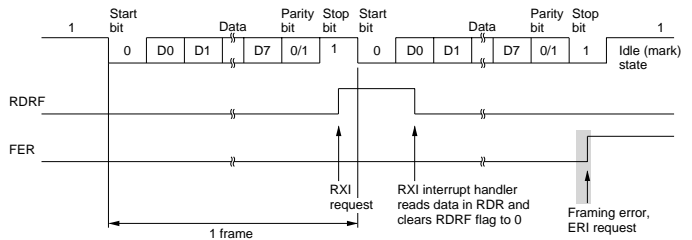

13.3.3 Multiprocessor Communication 495

Figure amended

Figure 13.11
Example of SCI Transmit Operation (8-Bit Data with Multiprocessor Bit and One Stop Bit)

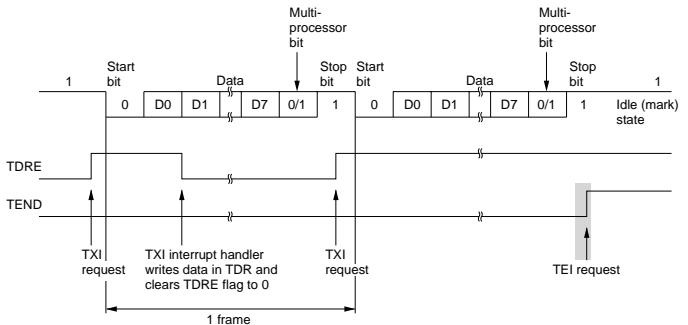

13.3.4 Synchronous Operation Clock 500

Description amended

An internal clock generated by the on-chip baud rate generator or an external clock input from the SCK pin can be selected by setting the C/A bit in SMR and the CKE1 and CKE0 bits in SCR. See table 13.9.

14.2.3 Serial Mode Register (SMR) Bit 7—GSM Mode (GM) 521

Table amended

Bit 7: GM	Description
0	Using the regular smart card interface mode <ul style="list-style-type: none"> The TEND flag is set 12.5 etu after the beginning of the start bit (Initial value) Clock output on/off control only
1	Using the GSM mode smart card interface mode <ul style="list-style-type: none"> The TEND flag is set 11.0 etu after the beginning of the start bit Clock output on/off and fixed-high/fixed-low control (set by SCR)

18.5.1 Flash Memory Control Register 1 (FLMCR1) 587

Note amended

Note: * Do not access flash memory while the E bit is set to 1.

Bit 1—Erase Bit (E)

Section 21 Electrical Characteristics 653, 654

Table amended

Table 21.1 Electrical Characteristics of H8/3048 Group and H8/3048B Group Products

Item		H8/3048B Group		
		H8/3048 ZTAT	H8/3048 F-ONE (Single Power Supply)	H8/3048B Mask ROM
Absolute maximum ratings	V _{pp} pin rating	Yes	—	■
Flash memory characteristics ^{*)4}		—	See table 21.11	—

Item	Page	Revision (See Manual for Details)																																								
21.2 Electrical Characteristics of H8/3048B (Mask ROM)	675 to 689	Preliminary deleted																																								
21.2.2 DC Characteristics Table 21.13 DC Characteristics (2)	678	Conditions amended Conditions: $V_{CC} = 3.0\text{ V to }3.6\text{ V}$, $AV_{CC} = 3.0\text{ V to }3.6\text{ V}$, $V_{REF} = 3.0\text{ V to }AV_{CC}$, $V_{SS} = AV_{SS} = 0\text{ V}^{*1}$, $T_a = -20^{\circ}\text{C to }+75^{\circ}\text{C}$ (regular specifications), $T_a = -40^{\circ}\text{C to }+85^{\circ}\text{C}$ (wide-range specifications)																																								
B.1 Addresses (For H8/3048F-ONE, H8/3048B Mask ROM Version)	742	Note amended Note: 4. Byte data must be used to access FLMCR1, FLMCR2, EBR, and RAMCR. Registers FLMCR1, FLMCR2, EBR, and RAMCR are implemented in the flash memory version only. The mask ROM version does not have these registers.																																								
B.3 Function ADCR	829	Table amended <table border="1"> <tr> <td>H8/3048F-ONE</td> <td>Not include this register</td> </tr> <tr> <td>H8/3048F</td> <td rowspan="6">Include this register</td> </tr> <tr> <td>H8/3048B mask ROM version</td> </tr> <tr> <td>H8/3048ZTAT</td> </tr> <tr> <td>H8/3048 mask ROM version</td> </tr> <tr> <td>H8/3047 mask ROM version</td> </tr> <tr> <td>H8/3045 mask ROM version</td> </tr> <tr> <td>H8/3044 mask ROM version</td> </tr> </table>	H8/3048F-ONE	Not include this register	H8/3048F	Include this register	H8/3048B mask ROM version	H8/3048ZTAT	H8/3048 mask ROM version	H8/3047 mask ROM version	H8/3045 mask ROM version	H8/3044 mask ROM version																														
H8/3048F-ONE	Not include this register																																									
H8/3048F	Include this register																																									
H8/3048B mask ROM version																																										
H8/3048ZTAT																																										
H8/3048 mask ROM version																																										
H8/3047 mask ROM version																																										
H8/3045 mask ROM version																																										
H8/3044 mask ROM version																																										
ADCR	829	Table amended <table border="1"> <tr> <td>H8/3048F-ONE</td> <td>Include this register</td> </tr> <tr> <td>H8/3048F</td> <td rowspan="6">Not include this register</td> </tr> <tr> <td>H8/3048B mask ROM version</td> </tr> <tr> <td>H8/3048ZTAT</td> </tr> <tr> <td>H8/3048 mask ROM version</td> </tr> <tr> <td>H8/3047 mask ROM version</td> </tr> <tr> <td>H8/3045 mask ROM version</td> </tr> <tr> <td>H8/3044 mask ROM version</td> </tr> </table>	H8/3048F-ONE	Include this register	H8/3048F	Not include this register	H8/3048B mask ROM version	H8/3048ZTAT	H8/3048 mask ROM version	H8/3047 mask ROM version	H8/3045 mask ROM version	H8/3044 mask ROM version																														
H8/3048F-ONE	Include this register																																									
H8/3048F	Not include this register																																									
H8/3048B mask ROM version																																										
H8/3048ZTAT																																										
H8/3048 mask ROM version																																										
H8/3047 mask ROM version																																										
H8/3045 mask ROM version																																										
H8/3044 mask ROM version																																										
SYSCR	833	Table amended Standby timer select 2 to 0 <table border="1"> <thead> <tr> <th>Bit 6</th> <th>Bit 5</th> <th>Bit 4</th> <th colspan="2">Standby Timer</th> </tr> </thead> <tbody> <tr> <td>STS2</td> <td>STS1</td> <td>STS0</td> <td>H8/3048F-ONE H8/3048B mask ROM version</td> <td>*</td> </tr> <tr> <td rowspan="4">0</td> <td rowspan="2">0</td> <td>0</td> <td>Waiting time = 8,192 states</td> <td>Waiting time = 8,192 states</td> </tr> <tr> <td>1</td> <td>Waiting time = 16,384 states</td> <td>Waiting time = 16,384 states</td> </tr> <tr> <td rowspan="2">1</td> <td>0</td> <td>Waiting time = 32,768 states</td> <td>Waiting time = 32,768 states</td> </tr> <tr> <td>1</td> <td>Waiting time = 65,536 states</td> <td>Waiting time = 65,536 states</td> </tr> <tr> <td rowspan="4">1</td> <td rowspan="2">0</td> <td>0</td> <td>Waiting time = 131,072 states</td> <td>Waiting time = 131,072 states</td> </tr> <tr> <td>1</td> <td>Waiting time = 262,144 states</td> <td>Waiting time = 1,024 states</td> </tr> <tr> <td rowspan="2">1</td> <td>0</td> <td>Waiting time = 1,024 states</td> <td>Illegal setting</td> </tr> <tr> <td>1</td> <td>Illegal setting</td> <td>Illegal setting</td> </tr> </tbody> </table> <p>Note: * H8/3048F H8/3048ZTAT H8/3048 mask ROM version H8/3047 mask ROM version H8/3045 mask ROM version H8/3044 mask ROM version</p>	Bit 6	Bit 5	Bit 4	Standby Timer		STS2	STS1	STS0	H8/3048F-ONE H8/3048B mask ROM version	*	0	0	0	Waiting time = 8,192 states	Waiting time = 8,192 states	1	Waiting time = 16,384 states	Waiting time = 16,384 states	1	0	Waiting time = 32,768 states	Waiting time = 32,768 states	1	Waiting time = 65,536 states	Waiting time = 65,536 states	1	0	0	Waiting time = 131,072 states	Waiting time = 131,072 states	1	Waiting time = 262,144 states	Waiting time = 1,024 states	1	0	Waiting time = 1,024 states	Illegal setting	1	Illegal setting	Illegal setting
Bit 6	Bit 5	Bit 4	Standby Timer																																							
STS2	STS1	STS0	H8/3048F-ONE H8/3048B mask ROM version	*																																						
0	0	0	Waiting time = 8,192 states	Waiting time = 8,192 states																																						
		1	Waiting time = 16,384 states	Waiting time = 16,384 states																																						
	1	0	Waiting time = 32,768 states	Waiting time = 32,768 states																																						
		1	Waiting time = 65,536 states	Waiting time = 65,536 states																																						
1	0	0	Waiting time = 131,072 states	Waiting time = 131,072 states																																						
		1	Waiting time = 262,144 states	Waiting time = 1,024 states																																						
	1	0	Waiting time = 1,024 states	Illegal setting																																						
		1	Illegal setting	Illegal setting																																						

Contents

Section 1 Overview	1
1.1 Overview	1
1.2 Block Diagram	6
1.3 Pin Description.....	7
1.3.1 Pin Arrangement	7
1.3.2 Pin Assignments in Each Mode	9
1.3.3 Pin Functions	15
1.4 Notes on H8/3048F-ONE (Single Power Supply)	20
1.4.1 Voltage Application	20
1.4.2 Product Type Names and Markings.....	21
1.4.3 Differences between H8/3048F and H8/3048F-ONE	21
1.4.4 V _{CL} Pin.....	26
1.4.5 Note on Changeover to H8/3048 Group Mask ROM Version.....	27
1.5 Setting Oscillation Settling Wait Time	28
1.6 Notes on Crystal Resonator Connection	28
Section 2 CPU	29
2.1 Overview	29
2.1.1 Features	29
2.1.2 Differences from H8/300 CPU	30
2.2 CPU Operating Modes	31
2.3 Address Space.....	32
2.4 Register Configuration.....	33
2.4.1 Overview.....	33
2.4.2 General Registers	34
2.4.3 Control Registers	35
2.4.4 Initial CPU Register Values	36
2.5 Data Formats.....	37
2.5.1 General Register Data Formats	37
2.5.2 Memory Data Formats	39
2.6 Instruction Set	40
2.6.1 Instruction Set Overview	40
2.6.2 Instructions and Addressing Modes	41
2.6.3 Tables of Instructions Classified by Function.....	42
2.6.4 Basic Instruction Formats	52
2.6.5 Notes on Use of Bit Manipulation Instructions.....	53
2.7 Addressing Modes and Effective Address Calculation	54
2.7.1 Addressing Modes	54

2.7.2	Effective Address Calculation	58
2.8	Processing States.....	62
2.8.1	Overview.....	62
2.8.2	Program Execution State.....	62
2.8.3	Exception-Handling State	63
2.8.4	Exception-Handling Sequences	64
2.8.5	Bus-Released State.....	65
2.8.6	Reset State.....	66
2.8.7	Power-Down State	66
2.9	Basic Operational Timing	67
2.9.1	Overview.....	67
2.9.2	On-Chip Memory Access Timing.....	67
2.9.3	On-Chip Supporting Module Access Timing	68
2.9.4	Access to External Address Space	69
Section 3 MCU Operating Modes		71
3.1	Overview.....	71
3.1.1	Operating Mode Selection	71
3.1.2	Register Configuration.....	72
3.2	Mode Control Register (MDCR)	72
3.3	System Control Register (SYSCR)	73
3.4	Operating Mode Descriptions	75
3.4.1	Mode 1	75
3.4.2	Mode 2	75
3.4.3	Mode 3	75
3.4.4	Mode 4.....	76
3.4.5	Mode 5.....	76
3.4.6	Mode 6.....	76
3.4.7	Mode 7.....	76
3.5	Pin Functions in Each Operating Mode	77
3.6	Memory Map in Each Operating Mode	77
Section 4 Exception Handling		81
4.1	Overview.....	81
4.1.1	Exception Handling Types and Priority.....	81
4.1.2	Exception Handling Operation.....	81
4.1.3	Exception Vector Table	82
4.2	Reset.....	84
4.2.1	Overview.....	84
4.2.2	Reset Sequence	84
4.2.3	Interrupts after Reset.....	87

4.3	Interrupts	88
4.4	Trap Instruction.....	89
4.5	Stack Status after Exception Handling.....	89
4.6	Notes on Stack Usage	90
Section 5 Interrupt Controller		91
5.1	Overview.....	91
5.1.1	Features.....	91
5.1.2	Block Diagram.....	92
5.1.3	Pin Configuration.....	93
5.1.4	Register Configuration.....	93
5.2	Register Descriptions	94
5.2.1	System Control Register (SYSCR).....	94
5.2.2	Interrupt Priority Registers A and B (IPRA, IPRB).....	95
5.2.3	IRQ Status Register (ISR).....	102
5.2.4	IRQ Enable Register (IER)	103
5.2.5	IRQ Sense Control Register (ISCR)	104
5.3	Interrupt Sources	105
5.3.1	External Interrupts	105
5.3.2	Internal Interrupts.....	107
5.3.3	Interrupt Vector Table.....	107
5.4	Interrupt Operation.....	111
5.4.1	Interrupt Handling Process.....	111
5.4.2	Interrupt Sequence	116
5.4.3	Interrupt Response Time.....	117
5.5	Usage Notes	118
5.5.1	Contention between Interrupt and Interrupt-Disabling Instruction.....	118
5.5.2	Instructions That Inhibit Interrupts	119
5.5.3	Interrupts during EEPMOV Instruction Execution.....	119
5.5.4	Usage Notes on External Interrupts	119
5.5.5	Notes on Non-Maskable Interrupts (NMI).....	121
Section 6 Bus Controller		123
6.1	Overview.....	123
6.1.1	Features.....	123
6.1.2	Block Diagram.....	124
6.1.3	Input/Output Pins	125
6.1.4	Register Configuration.....	126
6.2	Register Descriptions	126
6.2.1	Bus Width Control Register (ABWCR).....	126
6.2.2	Access State Control Register (ASTCR)	127

6.2.3	Wait Control Register (WCR).....	128
6.2.4	Wait State Controller Enable Register (WCER).....	129
6.2.5	Bus Release Control Register (BRCR).....	130
6.2.6	Chip Select Control Register (CSCR).....	132
6.3	Operation	133
6.3.1	Area Division.....	133
6.3.2	Chip Select Signals	135
6.3.3	Data Bus.....	136
6.3.4	Bus Control Signal Timing	137
6.3.5	Wait Modes.....	145
6.3.6	Interconnections with Memory (Example)	151
6.3.7	Bus Arbiter Operation.....	153
6.4	Usage Notes	156
6.4.1	Connection to Dynamic RAM and Pseudo-Static RAM.....	156
6.4.2	Register Write Timing	156
6.4.3	BREQ Input Timing.....	158
6.4.4	Transition To Software Standby Mode	158
Section 7 Refresh Controller.....		159
7.1	Overview.....	159
7.1.1	Features.....	159
7.1.2	Block Diagram.....	161
7.1.3	Input/Output Pins.....	162
7.1.4	Register Configuration.....	162
7.2	Register Descriptions	163
7.2.1	Refresh Control Register (RFSHCR).....	163
7.2.2	Refresh Timer Control/Status Register (RTMCSR)	166
7.2.3	Refresh Timer Counter (RTCNT).....	168
7.2.4	Refresh Time Constant Register (RTCOR)	168
7.3	Operation	169
7.3.1	Overview.....	169
7.3.2	DRAM Refresh Control.....	171
7.3.3	Pseudo-Static RAM Refresh Control	185
7.3.4	Interval Timer	190
7.4	Interrupt Source	196
7.5	Usage Notes	196
Section 8 DMA Controller.....		199
8.1	Overview.....	199
8.1.1	Features.....	199
8.1.2	Block Diagram.....	200

8.1.3	Functional Overview.....	201
8.1.4	Input/Output Pins.....	203
8.1.5	Register Configuration.....	203
8.2	Register Descriptions (Short Address Mode).....	205
8.2.1	Memory Address Registers (MAR).....	205
8.2.2	I/O Address Registers (IOAR).....	206
8.2.3	Execute Transfer Count Registers (ETCR).....	206
8.2.4	Data Transfer Control Registers (DTCR).....	208
8.3	Register Descriptions (Full Address Mode).....	211
8.3.1	Memory Address Registers (MAR).....	211
8.3.2	I/O Address Registers (IOAR).....	211
8.3.3	Execute Transfer Count Registers (ETCR).....	212
8.3.4	Data Transfer Control Registers (DTCR).....	214
8.4	Operation.....	220
8.4.1	Overview.....	220
8.4.2	I/O Mode.....	222
8.4.3	Idle Mode.....	224
8.4.4	Repeat Mode.....	227
8.4.5	Normal Mode.....	231
8.4.6	Block Transfer Mode.....	234
8.4.7	DMAC Activation.....	239
8.4.8	DMAC Bus Cycle.....	241
8.4.9	DMAC Multiple-Channel Operation.....	247
8.4.10	External Bus Requests, Refresh Controller, and DMAC.....	248
8.4.11	NMI Interrupts and DMAC.....	249
8.4.12	Aborting a DMA Transfer.....	250
8.4.13	Exiting Full Address Mode.....	251
8.4.14	DMAC States in Reset State, Standby Modes, and Sleep Mode.....	252
8.5	Interrupts.....	253
8.6	Usage Notes.....	254
8.6.1	Note on Word Data Transfer.....	254
8.6.2	DMAC Self-Access.....	254
8.6.3	Longword Access to Memory Address Registers.....	254
8.6.4	Note on Full Address Mode Setup.....	254
8.6.5	Note on Activating DMAC by Internal Interrupts.....	254
8.6.6	NMI Interrupts and Block Transfer Mode.....	256
8.6.7	Memory and I/O Address Register Values.....	256
8.6.8	Bus Cycle when Transfer Is Aborted.....	257
Section 9 I/O Ports.....		259
9.1	Overview.....	259

9.2	Port 1.....	263
9.2.1	Overview.....	263
9.2.2	Register Descriptions.....	264
9.3	Port 2.....	266
9.3.1	Overview.....	266
9.3.2	Register Descriptions.....	267
9.4	Port 3.....	270
9.4.1	Overview.....	270
9.4.2	Register Descriptions.....	270
9.5	Port 4.....	272
9.5.1	Overview.....	272
9.5.2	Register Descriptions.....	273
9.6	Port 5.....	276
9.6.1	Overview.....	276
9.6.2	Register Descriptions.....	277
9.7	Port 6.....	280
9.7.1	Overview.....	280
9.7.2	Register Descriptions.....	281
9.8	Port 7.....	284
9.8.1	Overview.....	284
9.8.2	Register Description.....	285
9.9	Port 8.....	286
9.9.1	Overview.....	286
9.9.2	Register Descriptions.....	287
9.10	Port 9.....	292
9.10.1	Overview.....	292
9.10.2	Register Descriptions.....	293
9.11	Port A.....	297
9.11.1	Overview.....	297
9.11.2	Register Descriptions.....	299
9.11.3	Pin Functions.....	301
9.12	Port B.....	309
9.12.1	Overview.....	309
9.12.2	Register Descriptions.....	311
9.12.3	Pin Functions.....	313
Section 10 16-Bit Integrated Timer Unit (ITU).....		319
10.1	Overview.....	319
10.1.1	Features.....	319
10.1.2	Block Diagrams.....	322
10.1.3	Input/Output Pins.....	327

10.1.4	Register Configuration.....	328
10.2	Register Descriptions	331
10.2.1	Timer Start Register (TSTR).....	331
10.2.2	Timer Synchro Register (TSNC)	332
10.2.3	Timer Mode Register (TMDR).....	334
10.2.4	Timer Function Control Register (TFCR).....	337
10.2.5	Timer Output Master Enable Register (TOER)	339
10.2.6	Timer Output Control Register (TOCR).....	341
10.2.7	Timer Counters (TCNT)	342
10.2.8	General Registers A, B (GRA, GRB)	343
10.2.9	Buffer Registers A, B (BRA, BRB).....	344
10.2.10	Timer Control Registers (TCR)	345
10.2.11	Timer I/O Control Register (TIOR).....	348
10.2.12	Timer Status Register (TSR).....	350
10.2.13	Timer Interrupt Enable Register (TIER).....	352
10.3	CPU Interface.....	353
10.3.1	16-Bit Accessible Registers	353
10.3.2	8-Bit Accessible Registers	356
10.4	Operation	357
10.4.1	Overview.....	357
10.4.2	Basic Functions.....	359
10.4.3	Synchronization	367
10.4.4	PWM Mode.....	369
10.4.5	Reset-Synchronized PWM Mode.....	373
10.4.6	Complementary PWM Mode.....	376
10.4.7	Phase Counting Mode.....	385
10.4.8	Buffering.....	387
10.4.9	ITU Output Timing	392
10.5	Interrupts	395
10.5.1	Setting of Status Flags	395
10.5.2	Timing of Clearing of Status Flags.....	398
10.5.3	Interrupt Sources and DMA Controller Activation.....	398
10.6	Usage Notes	400
Section 11 Programmable Timing Pattern Controller.....		415
11.1	Overview.....	415
11.1.1	Features.....	415
11.1.2	Block Diagram.....	416
11.1.3	TPC Pins	417
11.1.4	Registers.....	418
11.2	Register Descriptions	419

11.2.1	Port A Data Direction Register (PADDR)	419
11.2.2	Port A Data Register (PADR)	419
11.2.3	Port B Data Direction Register (PBDDR).....	420
11.2.4	Port B Data Register (PBDR)	420
11.2.5	Next Data Register A (NDRA)	421
11.2.6	Next Data Register B (NDRB).....	423
11.2.7	Next Data Enable Register A (NDERA).....	425
11.2.8	Next Data Enable Register B (NDERB)	426
11.2.9	TPC Output Control Register (TPCR)	427
11.2.10	TPC Output Mode Register (TPMR)	429
11.3	Operation	431
11.3.1	Overview.....	431
11.3.2	Output Timing.....	432
11.3.3	Normal TPC Output.....	433
11.3.4	Non-Overlapping TPC Output.....	435
11.3.5	TPC Output Triggering by Input Capture	437
11.4	Usage Notes	438
11.4.1	Operation of TPC Output Pins	438
11.4.2	Note on Non-Overlapping Output.....	438
Section 12 Watchdog Timer		441
12.1	Overview.....	441
12.1.1	Features.....	441
12.1.2	Block Diagram	442
12.1.3	Pin Configuration.....	442
12.1.4	Register Configuration.....	443
12.2	Register Descriptions	443
12.2.1	Timer Counter (TCNT).....	443
12.2.2	Timer Control/Status Register (TCSR)	444
12.2.3	Reset Control/Status Register (RSTCSR).....	446
12.2.4	Notes on Register Rewriting	447
12.3	Operation	449
12.3.1	Watchdog Timer Operation	449
12.3.2	Interval Timer Operation	450
12.3.3	Timing of Setting of Overflow Flag (OVF).....	450
12.3.4	Timing of Setting of Watchdog Timer Reset Bit (WRST)	451
12.4	Interrupts.....	452
12.5	Usage Notes	452
12.6	Notes.....	453

Section 13	Serial Communication Interface	455
13.1	Overview.....	455
13.1.1	Features.....	455
13.1.2	Block Diagram.....	457
13.1.3	Input/Output Pins.....	458
13.1.4	Register Configuration.....	458
13.2	Register Descriptions	459
13.2.1	Receive Shift Register (RSR)	459
13.2.2	Receive Data Register (RDR).....	459
13.2.3	Transmit Shift Register (TSR).....	460
13.2.4	Transmit Data Register (TDR).....	460
13.2.5	Serial Mode Register (SMR).....	461
13.2.6	Serial Control Register (SCR).....	464
13.2.7	Serial Status Register (SSR)	468
13.2.8	Bit Rate Register (BRR)	472
13.3	Operation	481
13.3.1	Overview.....	481
13.3.2	Operation in Asynchronous Mode	483
13.3.3	Multiprocessor Communication.....	492
13.3.4	Synchronous Operation.....	499
13.4	SCI Interrupts.....	508
13.5	Usage Notes	509
Section 14	Smart Card Interface	515
14.1	Overview.....	515
14.1.1	Features.....	515
14.1.2	Block Diagram.....	516
14.1.3	Input/Output Pins.....	517
14.1.4	Register Configuration.....	517
14.2	Register Descriptions	518
14.2.1	Smart Card Mode Register (SCMR).....	518
14.2.2	Serial Status Register (SSR)	519
14.2.3	Serial Mode Register (SMR).....	521
14.2.4	Serial Control Register (SCR).....	522
14.3	Operation	523
14.3.1	Overview.....	523
14.3.2	Pin Connections	523
14.3.3	Data Format	524
14.3.4	Register Settings	526
14.3.5	Clock.....	528
14.3.6	Transmitting and Receiving Data	530

14.4	Usage Notes	538
Section 15	A/D Converter.....	541
15.1	Overview.....	541
15.1.1	Features.....	541
15.1.2	Block Diagram.....	542
15.1.3	Input Pins.....	543
15.1.4	Register Configuration.....	544
15.2	Register Descriptions	545
15.2.1	A/D Data Registers A to D (ADDRA to ADDR D).....	545
15.2.2	A/D Control/Status Register (ADCSR)	546
15.2.3	A/D Control Register (ADCR)	548
15.3	CPU Interface.....	549
15.4	Operation	550
15.4.1	Single Mode (SCAN = 0)	550
15.4.2	Scan Mode (SCAN = 1).....	552
15.4.3	Input Sampling and A/D Conversion Time	554
15.4.4	External Trigger Input Timing.....	555
15.5	Interrupts.....	556
15.6	Usage Notes	556
Section 16	D/A Converter.....	561
16.1	Overview	561
16.1.1	Features	561
16.1.2	Block Diagram.....	562
16.1.3	Input/Output Pins.....	563
16.1.4	Register Configuration.....	563
16.2	Register Descriptions	564
16.2.1	D/A Data Registers 0 and 1 (DADR0, DADR1)	564
16.2.2	D/A Control Register (DACR)	564
16.2.3	D/A Standby Control Register (DASTCR).....	566
16.3	Operation	567
16.4	D/A Output Control	568
Section 17	RAM	569
17.1	Overview.....	569
17.1.1	Block Diagram.....	570
17.1.2	Register Configuration.....	570
17.2	System Control Register (SYSCR).....	571
17.3	Operation	572

Section 18	ROM (H8/3048F-ONE: Single Power Supply, H8/3048B Mask ROM Version).....	573
18.1	Flash Memory Overview	573
18.1.1	Notes on H8/3048F-ONE (Single Power Supply)	573
18.1.2	Mode Pin Settings	574
18.2	Flash Memory Features.....	575
18.2.1	Block Diagram.....	576
18.2.2	Mode Transitions	576
18.2.3	On-Board Programming Modes.....	579
18.2.4	Flash Memory Emulation in RAM	581
18.2.5	Differences between Boot Mode and User Program Mode	582
18.2.6	Block Configuration	583
18.3	Flash Memory Pin Configuration.....	583
18.4	Flash Memory Register Configuration.....	584
18.5	Flash Memory Register Descriptions.....	584
18.5.1	Flash Memory Control Register 1 (FLMCR1).....	584
18.5.2	Flash Memory Control Register 2 (FLMCR2).....	588
18.5.3	Erase Block Register (EBR)	589
18.5.4	RAM Control Register (RAMCR).....	590
18.6	Flash Memory On-Board Programming Modes.....	592
18.6.1	Boot Mode	593
18.6.2	User Program Mode.....	598
18.7	Programming/Erasing Flash Memory	600
18.7.1	Program Mode	602
18.7.2	Program-Verify Mode.....	603
18.7.3	Erase Mode	607
18.7.4	Erase-Verify Mode	607
18.8	Flash Memory Protection.....	609
18.8.1	Hardware Protection	609
18.8.2	Software Protection.....	611
18.8.3	Error Protection.....	612
18.8.4	NMI Input Disable Conditions.....	614
18.9	Flash Memory Emulation in RAM	615
18.10	Flash Memory PROM Mode.....	616
18.10.1	Socket Adapters and Memory Map	617
18.10.2	Notes on Use of PROM Mode	618
18.11	Notes on Flash Memory Programming/Erasing	619
18.12	Mask ROM (H8/3048B Mask ROM Version) Overviews.....	625
18.12.1	Block Diagram.....	625
18.13	Notes on Ordering Mask ROM Version Chips	626

18.14	Notes when Converting the F-ZTAT (Single Power Supply) Application Software to the Mask-ROM Versions	627
Section 19	Clock Pulse Generator	629
19.1	Overview.....	629
19.1.1	Block Diagram.....	630
19.2	Oscillator Circuit.....	630
19.2.1	Connecting a Crystal Resonator.....	630
19.2.2	External Clock Input.....	633
19.3	Duty Adjustment Circuit.....	636
19.4	Prescalers	636
19.5	Frequency Divider	636
19.5.1	Register Configuration.....	637
19.5.2	Division Control Register (DIVCR)	637
19.5.3	Usage Notes	638
Section 20	Power-Down State	639
20.1	Overview.....	639
20.2	Register Configuration.....	641
20.2.1	System Control Register (SYSCR).....	641
20.2.2	Module Standby Control Register (MSTCR).....	643
20.3	Sleep Mode	645
20.3.1	Transition to Sleep Mode.....	645
20.3.2	Exit from Sleep Mode.....	645
20.4	Software Standby Mode.....	645
20.4.1	Transition to Software Standby Mode	645
20.4.2	Exit from Software Standby Mode	646
20.4.3	Selection of Waiting Time for Exit from Software Standby Mode.....	646
20.4.4	Sample Application of Software Standby Mode.....	648
20.4.5	Note.....	648
20.5	Hardware Standby Mode	649
20.5.1	Transition to Hardware Standby Mode.....	649
20.5.2	Exit from Hardware Standby Mode	649
20.5.3	Timing for Hardware Standby Mode	649
20.6	Module Standby Function.....	650
20.6.1	Module Standby Timing	650
20.6.2	Read/Write in Module Standby.....	650
20.6.3	Usage Notes	651
20.7	System Clock Output Disabling Function.....	652

Section 21	Electrical Characteristics.....	653
21.1	Electrical Characteristics of H8/3048F-ONE (Single-Power Supply)	655
21.1.1	Absolute Maximum Ratings	655
21.1.2	DC Characteristics	656
21.1.3	AC Characteristics	663
21.1.4	A/D Conversion Characteristics.....	669
21.1.5	D/A Conversion Characteristics.....	670
21.1.6	Flash Memory Characteristics	671
21.2	Electrical Characteristics of H8/3048B (Mask ROM)	675
21.2.1	Absolute Maximum Ratings	675
21.2.2	DC Characteristics	676
21.2.3	AC Characteristics	682
21.2.4	A/D Conversion Characteristics.....	688
21.2.5	D/A Conversion Characteristics.....	689
21.3	Operational Timing	690
21.3.1	Bus Timing	690
21.3.2	Refresh Controller Bus Timing.....	694
21.3.3	Control Signal Timing	699
21.3.4	Clock Timing	701
21.3.5	TPC and I/O Port Timing.....	701
21.3.6	ITU Timing.....	702
21.3.7	SCI Input/Output Timing.....	703
21.3.8	DMAC Timing.....	704
Appendix A	Instruction Set.....	705
A.1	Instruction List.....	705
A.2	Operation Code Map.....	720
A.3	Number of States Required for Execution	723
Appendix B	Internal I/O Register	734
B.1	Addresses (For H8/3048F-ONE, H8/3048B Mask ROM Version)	735
B.2	Addresses (For H8/3048F, H8/3048ZTAT, H8/3048 Mask-ROM, H8/3047 Mask-ROM, H8/3045 Mask-ROM, and H8/3044 Mask-ROM Versions)	743
B.3	Function	751
Appendix C	I/O Port Block Diagrams.....	837
C.1	Port 1 Block Diagram	837
C.2	Port 2 Block Diagram	838
C.3	Port 3 Block Diagram	839
C.4	Port 4 Block Diagram	840
C.5	Port 5 Block Diagram	841

C.6	Port 6 Block Diagrams.....	842
C.7	Port 7 Block Diagrams.....	846
C.8	Port 8 Block Diagrams.....	847
C.9	Port 9 Block Diagrams.....	850
C.10	Port A Block Diagrams.....	854
C.11	Port B Block Diagrams.....	858
Appendix D	Pin States.....	862
D.1	Port States in Each Mode.....	862
D.2	Pin States at Reset.....	865
Appendix E	Timing of Transition to and Recovery from Hardware Standby Mode.....	868
Appendix F	Product Code Lineup.....	869
Appendix G	Package Dimensions.....	871

Section 1 Overview

1.1 Overview

The H8/3048B Group is a series of microcontrollers (MCUs) that integrate system supporting functions together with an H8/300H CPU core having an original Renesas Technology architecture. In addition, the H8/3048F-ONE is equipped with an on-chip emulator (E10T)^{*2}.

The H8/300H CPU has a 32-bit internal architecture with sixteen 16-bit general registers, and a concise, optimized instruction set designed for speed. It can address a 16-Mbyte linear address space. Its instruction set is upward-compatible at the object-code level with the H8/300 CPU, enabling easy porting of software from the H8/300 Series.

The on-chip system supporting functions include ROM, RAM, a 16-bit integrated timer unit (ITU), a programmable timing pattern controller (TPC), a watchdog timer (WDT), a serial communication interface (SCI), an A/D converter, a D/A converter, I/O ports, a direct memory access controller (DMAC), a refresh controller, and other facilities.

The H8/3048B Group has 128 kbytes of on-chip ROM and 4 kbytes of on-chip RAM.

Seven MCU operating modes offer a choice of data bus width and address space size. The modes (modes 1 to 7) include one single-chip mode and six expanded modes.

In addition to mask ROM products, the H8/3048B Group includes F-ZTAT^{TM*1} version products with on-chip user-programmable flash memory. It enables users to respond quickly and flexibly to changing application specifications as well as to conditions when ramping up from initial to full volume production. The on-chip emulator (E10T)^{*2} is capable of direct emulation of the microcontroller when mounted in the user's system, thereby making possible on-board program debugging.

Table 1.1 summarizes the features of the H8/3048B Group.

- Notes:
1. F-ZTAT (Flexible ZTATTM) is a trademark of Renesas Technology Corp.
 2. An on-chip emulator (E10T) is not provided in the mask ROM version.

Table 1.1 Features

Feature	Description
CPU	<p>Upward-compatible with the H8/300 CPU at the object-code level</p> <ul style="list-style-type: none"> • General-register machine <ul style="list-style-type: none"> — Sixteen 16-bit general registers (also usable as sixteen 8-bit registers + eight 16-bit registers or eight 32-bit registers) • High-speed operation (flash memory version) <ul style="list-style-type: none"> — Maximum clock rate: 25 MHz — Add/subtract: 80 ns — Multiply/divide: 560 ns — 16-Mbyte address space • Instruction features <ul style="list-style-type: none"> — 8/16/32-bit data transfer, arithmetic, and logic instructions — Signed and unsigned multiply instructions (8 bits × 8 bits, 16 bits × 16 bits) — Signed and unsigned divide instructions (16 bits ÷ 8 bits, 32 bits ÷ 16 bits) — Bit accumulator function — Bit manipulation instructions with register-indirect specification of bit positions
Memory	<ul style="list-style-type: none"> • ROM: 128 kbytes • RAM: 4 kbytes
Interrupt controller	<ul style="list-style-type: none"> • Seven external interrupt pins: NMI, \overline{IRQ}_0 to \overline{IRQ}_5 • 30 internal interrupts • Three selectable interrupt priority levels
Bus controller	<ul style="list-style-type: none"> • Address space can be partitioned into eight areas, with independent bus specifications in each area • Chip select output available for areas 0 to 7 • 8-bit access or 16-bit access selectable for each area • Two-state or three-state access selectable for each area • Selection of four wait modes • Bus arbitration function

Feature	Description
Refresh controller	<ul style="list-style-type: none"> • DRAM refresh <ul style="list-style-type: none"> — Directly connectable to 16-bit-wide DRAM — CAS-before-RAS refresh — Self-refresh mode selectable • Pseudo-static RAM refresh <ul style="list-style-type: none"> — Self-refresh mode selectable • Usable as an interval timer
DMA controller (DMAC)	<ul style="list-style-type: none"> • Short address mode <ul style="list-style-type: none"> — Maximum four channels available — Selection of I/O mode, idle mode, or repeat mode — Can be activated by compare match/input capture A interrupts from ITU channels 0 to 3, transmit-data-empty and receive-data-full interrupts from SCI channel 0, or external requests • Full address mode <ul style="list-style-type: none"> — Maximum two channels available — Selection of normal mode or block transfer mode — Can be activated by compare match/input capture A interrupts from ITU channels 0 to 3, external requests, or auto-request
16-bit integrated timer unit (ITU)	<ul style="list-style-type: none"> • Five 16-bit timer channels, capable of processing up to 12 pulse outputs or 10 pulse inputs • One 16-bit timer counter (channels 0 to 4) • Two multiplexed output compare/input capture pins (channels 0 to 4) • Operation can be synchronized (channels 0 to 4) • PWM mode available (channels 0 to 4) • Phase counting mode available (channel 2) • Buffering available (channels 3 and 4) • Reset-synchronized PWM mode available (channels 3 and 4) • Complementary PWM mode available (channels 3 and 4) • DMAC can be activated by compare match/input capture A interrupts (channels 0 to 3)

Feature	Description																																								
Programmable timing pattern controller (TPC)	<ul style="list-style-type: none"> Maximum 16-bit pulse output, using ITU as time base Up to four 4-bit pulse output groups (or one 16-bit group, or two 8-bit groups) Non-overlap mode available Output data can be transferred by DMAC 																																								
Watchdog timer (WDT), 1 channel	<ul style="list-style-type: none"> Reset signal can be generated by overflow Usable as an interval timer 																																								
Serial communication interface (SCI), 2 channels	<ul style="list-style-type: none"> Selection of asynchronous or synchronous mode Full duplex: can transmit and receive simultaneously On-chip baud-rate generator Smart card interface functions added (SCI0 only) 																																								
A/D converter	<ul style="list-style-type: none"> Resolution: 10 bits Eight channels, with selection of single or scan mode Variable analog conversion voltage range Sample-and-hold function A/D conversion can be externally triggered 																																								
D/A converter	<ul style="list-style-type: none"> Resolution: 8 bits Two channels D/A outputs can be sustained in software standby mode 																																								
I/O ports	<ul style="list-style-type: none"> 70 input/output pins 8 input-only pins 																																								
Operating modes	<ul style="list-style-type: none"> Seven MCU operating modes <table border="1"> <thead> <tr> <th>Mode</th> <th>Address Space</th> <th>Address Pins</th> <th>Initial Bus Width</th> <th>Max. Bus Width</th> </tr> </thead> <tbody> <tr> <td>Mode 1</td> <td>1 Mbyte</td> <td>A₁₉ to A₀</td> <td>8 bits</td> <td>16 bits</td> </tr> <tr> <td>Mode 2</td> <td>1 Mbyte</td> <td>A₁₉ to A₀</td> <td>16 bits</td> <td>16 bits</td> </tr> <tr> <td>Mode 3</td> <td>16 Mbytes</td> <td>A₂₃ to A₀</td> <td>8 bits</td> <td>16 bits</td> </tr> <tr> <td>Mode 4</td> <td>16 Mbytes</td> <td>A₂₃ to A₀</td> <td>16 bits</td> <td>16 bits</td> </tr> <tr> <td>Mode 5</td> <td>1 Mbyte</td> <td>A₁₉ to A₀</td> <td>8 bits</td> <td>16 bits</td> </tr> <tr> <td>Mode 6</td> <td>16 Mbytes</td> <td>A₂₃ to A₀</td> <td>8 bits</td> <td>16 bits</td> </tr> <tr> <td>Mode 7</td> <td>1 Mbyte</td> <td>—</td> <td>—</td> <td>—</td> </tr> </tbody> </table>	Mode	Address Space	Address Pins	Initial Bus Width	Max. Bus Width	Mode 1	1 Mbyte	A ₁₉ to A ₀	8 bits	16 bits	Mode 2	1 Mbyte	A ₁₉ to A ₀	16 bits	16 bits	Mode 3	16 Mbytes	A ₂₃ to A ₀	8 bits	16 bits	Mode 4	16 Mbytes	A ₂₃ to A ₀	16 bits	16 bits	Mode 5	1 Mbyte	A ₁₉ to A ₀	8 bits	16 bits	Mode 6	16 Mbytes	A ₂₃ to A ₀	8 bits	16 bits	Mode 7	1 Mbyte	—	—	—
	Mode	Address Space	Address Pins	Initial Bus Width	Max. Bus Width																																				
	Mode 1	1 Mbyte	A ₁₉ to A ₀	8 bits	16 bits																																				
	Mode 2	1 Mbyte	A ₁₉ to A ₀	16 bits	16 bits																																				
	Mode 3	16 Mbytes	A ₂₃ to A ₀	8 bits	16 bits																																				
	Mode 4	16 Mbytes	A ₂₃ to A ₀	16 bits	16 bits																																				
	Mode 5	1 Mbyte	A ₁₉ to A ₀	8 bits	16 bits																																				
	Mode 6	16 Mbytes	A ₂₃ to A ₀	8 bits	16 bits																																				
	Mode 7	1 Mbyte	—	—	—																																				
<ul style="list-style-type: none"> On-chip ROM is disabled in modes 1 to 4 																																									

Feature	Description				
Power-down state	<ul style="list-style-type: none"> • Sleep mode • Software standby mode • Hardware standby mode • Module standby function • Programmable system clock frequency division 				
Other features	<ul style="list-style-type: none"> • On-chip clock pulse generator 				
Product lineup	Model (5 V)	Model (3 V)	Package	ROM	Remarks
	HD64F3048BTE	HD64F3048BVTE	100-pin TQFP (TFP-100B)	Flash memory	E10T is installed
	HD64F3048BF	HD64F3048BVF	100-pin QFP (FP-100B)		
	HD6433048BTE	HD6433048BVTE	100-pin TQFP (TFP-100B)	Mask ROM	E10T is not installed
	HD6433048BF	HD6433048BVF	100-pin QFP (FP-100B)		

1.2 Block Diagram

Figure 1.1 shows an internal block diagram.

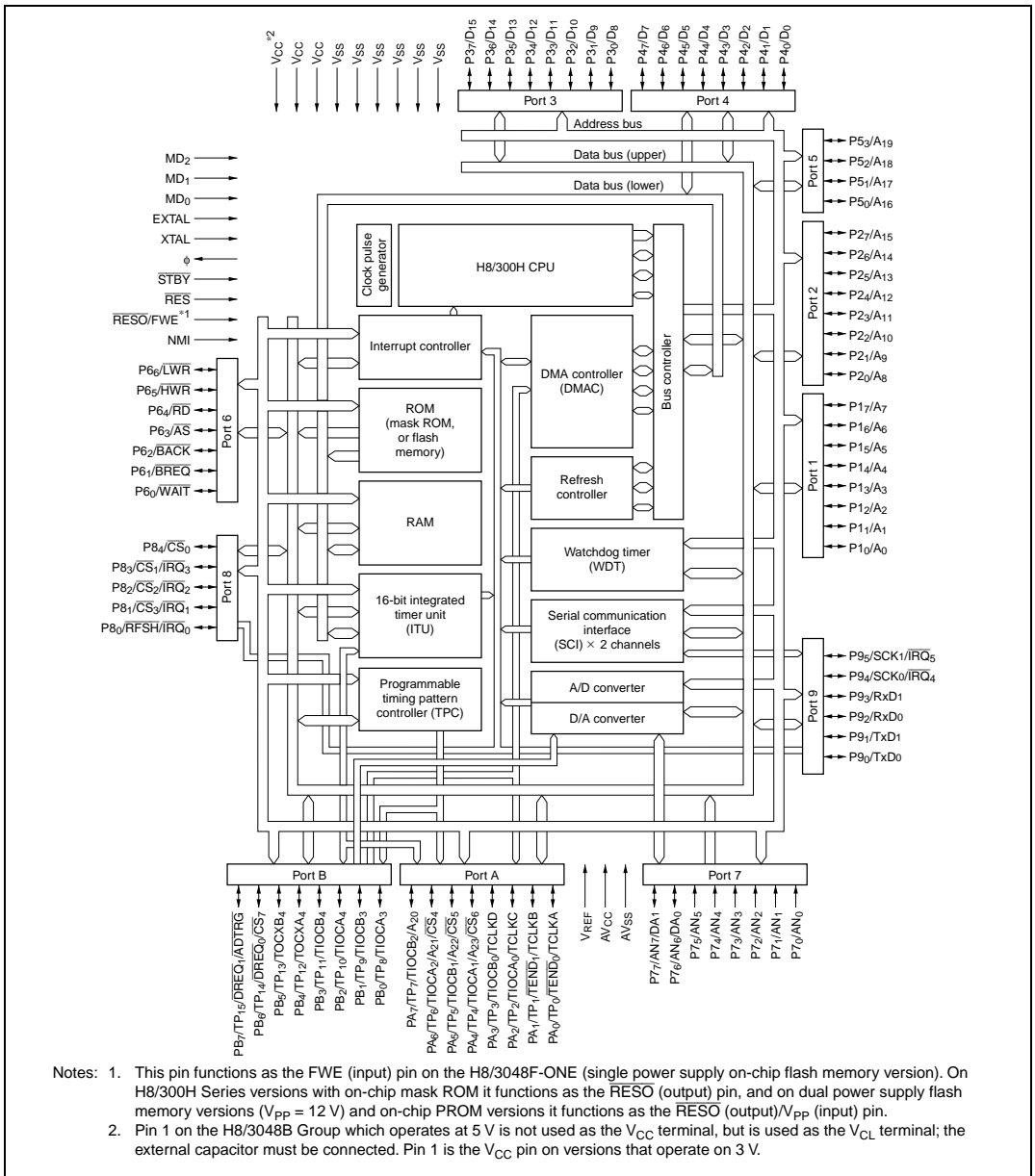

Figure 1.1 Block Diagram

1.3 Pin Description

1.3.1 Pin Arrangement

Figure 1.3 shows the pin arrangement of the H8/3048B Group.

The pin arrangement of the H8/3048B Group is shown in figure 1.3. Differences in the H8/3048 Group pin arrangements are shown in table 1.2. The 5 V operation models of the H8/3048B Group have a V_{CL} pin. The 3 V operation models of the H8/3048B Group have pin 1, which is the V_{CC} power supply pin. See section 1.4, Notes on H8/3048F-ONE (Single Power Supply). Except for the differences shown in table 1.2, the pin arrangements are the same.

Table 1.2 Comparison of H8/3048B Group and H8/3048 Group Pin Arrangements

Package	Pin Number	H8/3048F-ONE		H8/3048B Mask ROM Version		H8/3048F	H8/3048 ZTAT	H8/3048 Mask ROM Version	H8/3047 Mask ROM Version	H8/3045 Mask ROM Version	H8/3044 Mask ROM Version
		5 V Operation Model	3 V Operation Model	5 V Operation Model	3 V Operation Model						
FP-100B (TFP-100B)	1	V_{CL}	V_{CC}	V_{CL}	V_{CC}	V_{CC}	V_{CC}	V_{CC}	V_{CC}	V_{CC}	V_{CC}
	10	FWE	FWE	RESO	RESO	$\frac{V_{PP}}{RESO}$	$\frac{V_{PP}}{RESO}$	RESO	RESO	RESO	RESO

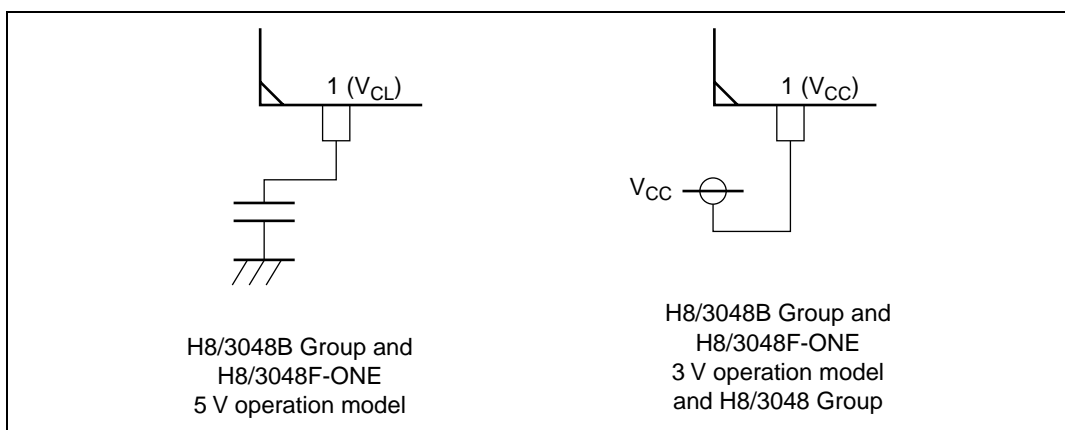

Figure 1.2 Connection of Pin 1

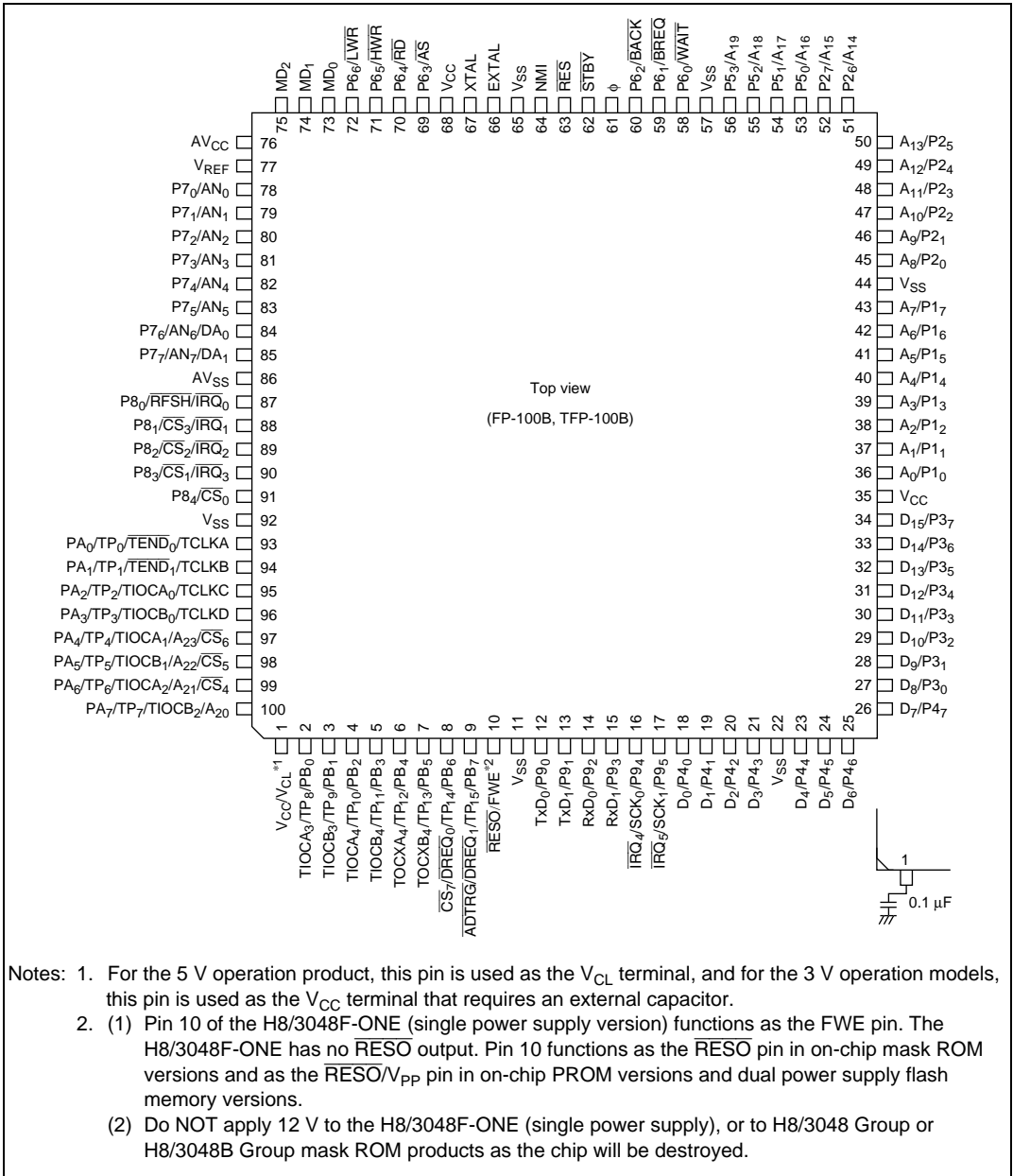

Figure 1.3 H8/3048B Group Pin Arrangement (FP-100B or TFP-100B, Top View)

1.3.2 Pin Assignments in Each Mode

Table 1.3 lists the pin assignments in each mode.

Table 1.3 Pin Assignments in Each Mode (FP-100B or TFP-100B)

Pin No.	Pin Name							PROM Mode		Remarks
	Mode 1	Mode 2	Mode 3	Mode 4	Mode 5	Mode 6	Mode 7	EPROM	Flash	
1 ^{*3}	$V_{CL}(V_{CC})$	$V_{CL}(V_{CC})$	$V_{CL}(V_{CC})$	$V_{CL}(V_{CC})$	$V_{CL}(V_{CC})$	$V_{CL}(V_{CC})$	$V_{CL}(V_{CC})$	—	$V_{CL}(V_{CC})$	Flash memory version with single power supply. H8/3048 B mask-ROM version
	V_{CC}	V_{CC}	V_{CC}	V_{CC}	V_{CC}	V_{CC}	V_{CC}	V_{CC}	V_{CC}	H8/3048 Group, Mask ROM version, PROM version and flash memory version with dual power supply.
2	PB ₂ /TP ₈ / TIOCA ₃	PB ₀ /TP ₆ / TIOCA ₃	PB ₁ /TP ₆ / TIOCA ₃	PB ₀ /TP ₆ / TIOCA ₃	PB ₀ /TP ₆ / TIOCA ₃	PB ₀ /TP ₆ / TIOCA ₃	PB ₀ /TP ₆ / TIOCA ₃	NC	NC	
3	PB ₁ /TP ₉ / TIOCB ₃	PB ₃ /TP ₇ / TIOCB ₃	PB ₁ /TP ₉ / TIOCB ₃	PB ₁ /TP ₉ / TIOCB ₃	PB ₁ /TP ₉ / TIOCB ₃	PB ₃ /TP ₇ / TIOCB ₃	PB ₁ /TP ₉ / TIOCB ₃	NC	NC	
4	PB ₂ /TP ₁₀ / TIOCA ₄	PB ₂ /TP ₁₀ / TIOCA ₄	PB ₂ /TP ₁₀ / TIOCA ₄	PB ₂ /TP ₁₀ / TIOCA ₄	PB ₂ /TP ₁₀ / TIOCA ₄	PB ₂ /TP ₁₀ / TIOCA ₄	PB ₂ /TP ₁₀ / TIOCA ₄	NC	NC	
5	PB ₂ /TP ₁₁ / TIOCB ₄	PB ₂ /TP ₁₁ / TIOCB ₄	PB ₂ /TP ₁₁ / TIOCB ₄	PB ₂ /TP ₁₁ / TIOCB ₄	PB ₂ /TP ₁₁ / TIOCB ₄	PB ₂ /TP ₁₁ / TIOCB ₄	PB ₂ /TP ₁₁ / TIOCB ₄	NC	NC	
6	PB ₄ /TP ₁₂ / TOCXA ₄	PB ₄ /TP ₁₂ / TOCXA ₄	PB ₄ /TP ₁₂ / TOCXA ₄	PB ₄ /TP ₁₂ / TOCXA ₄	PB ₄ /TP ₁₂ / TOCXA ₄	PB ₄ /TP ₁₂ / TOCXA ₄	PB ₄ /TP ₁₂ / TOCXA ₄	NC	NC	
7	PB ₂ /TP ₁₃ / TOCXB ₄	PB ₂ /TP ₁₃ / TOCXB ₄	PB ₂ /TP ₁₃ / TOCXB ₄	PB ₂ /TP ₁₃ / TOCXB ₄	PB ₂ /TP ₁₃ / TOCXB ₄	PB ₂ /TP ₁₃ / TOCXB ₄	PB ₂ /TP ₁₃ / TOCXB ₄	NC	NC	

Pin Name

Pin No.	Pin Name							PROM Mode		Remarks
	Mode 1	Mode 2	Mode 3	Mode 4	Mode 5	Mode 6	Mode 7	EPROM	Flash	
8	PB ₆ /TP ₁₄ / DREQ ₀ / CS ₇	PB ₆ /TP ₁₄ / DREQ ₀ / CS ₇	PB ₆ /TP ₁₄ / DREQ ₀ / CS ₇	PB ₆ /TP ₁₄ / DREQ ₀ / CS ₇	PB ₆ /TP ₁₄ / DREQ ₀ / CS ₇	PB ₆ /TP ₁₄ / DREQ ₀ / CS ₇	PB ₆ /TP ₁₄ / DREQ ₀ / CS ₇	NC	NC	
9	PB ₇ /TP ₁₅ / DREQ ₁ / ADTRG	PB ₇ /TP ₁₅ / DREQ ₁ / ADTRG	PB ₇ /TP ₁₅ / DREQ ₁ / ADTRG	PB ₇ /TP ₁₅ / DREQ ₁ / ADTRG	PB ₇ /TP ₁₅ / DREQ ₁ / ADTRG	PB ₇ /TP ₁₅ / DREQ ₁ / ADTRG	PB ₇ /TP ₁₅ / DREQ ₁ / ADTRG	NC	NC	
10 ^{*4}	FWE	FWE	FWE	FWE	FWE	FWE	FWE	—	FWE	Flash memory version with single power supply.
	RESO	RESO	RESO	RESO	RESO	RESO	RESO	V _{pp}	V _{pp}	Mask ROM version, PROM version and flash memory version with dual power supply.
11	V _{ss}	V _{ss}	V _{ss}	V _{ss}	V _{ss}	V _{ss}	V _{ss}	V _{ss}	V _{ss}	
12	P9 ₀ /TxD ₀	P9 ₀ /TxD ₀	P9 ₀ /TxD ₀	P9 ₀ /TxD ₀	P9 ₀ /TxD ₀	P9 ₀ /TxD ₀	P9 ₀ /TxD ₀	NC	NC	
13	P9 ₁ /TxD ₁	P9 ₁ /TxD ₁	P9 ₁ /TxD ₁	P9 ₁ /TxD ₁	P9 ₁ /TxD ₁	P9 ₁ /TxD ₁	P9 ₁ /TxD ₁	NC	NC	
14	P9 ₂ /RxD ₀	P9 ₂ /RxD ₀	P9 ₂ /RxD ₀	P9 ₂ /RxD ₀	P9 ₂ /RxD ₀	P9 ₂ /RxD ₀	P9 ₂ /RxD ₀	NC	NC	
15	P9 ₃ /RxD ₁	P9 ₃ /RxD ₁	P9 ₃ /RxD ₁	P9 ₃ /RxD ₁	P9 ₃ /RxD ₁	P9 ₃ /RxD ₁	P9 ₃ /RxD ₁	NC	NC	
16	P9 ₄ /SCK ₀ / IRQ ₄	P9 ₄ /SCK ₀ / IRQ ₄	P9 ₄ /SCK ₀ / IRQ ₄	P9 ₄ /SCK ₀ / IRQ ₄	P9 ₄ /SCK ₀ / IRQ ₄	P9 ₄ /SCK ₀ / IRQ ₄	P9 ₄ /SCK ₀ / IRQ ₄	NC	NC	
17	P9 ₅ /SCK ₁ / IRQ ₅	P9 ₅ /SCK ₁ / IRQ ₅	P9 ₅ /SCK ₁ / IRQ ₅	P9 ₅ /SCK ₁ / IRQ ₅	P9 ₅ /SCK ₁ / IRQ ₅	P9 ₅ /SCK ₁ / IRQ ₅	P9 ₅ /SCK ₁ / IRQ ₅	NC	NC	
18	P4 ₀ /D ₀ ^{*1}	P4 ₀ /D ₀ ^{*2}	P4 ₀ /D ₀ ^{*1}	P4 ₀ /D ₀ ^{*2}	P4 ₀ /D ₀ ^{*1}	P4 ₀ /D ₀ ^{*1}	P4 ₀	NC	NC	
19	P4 ₁ /D ₁ ^{*1}	P4 ₁ /D ₁ ^{*2}	P4 ₁ /D ₁ ^{*1}	P4 ₁ /D ₁ ^{*2}	P4 ₁ /D ₁ ^{*1}	P4 ₁ /D ₁ ^{*1}	P4 ₁	NC	NC	
20	P4 ₂ /D ₂ ^{*1}	P4 ₂ /D ₂ ^{*2}	P4 ₂ /D ₂ ^{*1}	P4 ₂ /D ₂ ^{*2}	P4 ₂ /D ₂ ^{*1}	P4 ₂ /D ₂ ^{*1}	P4 ₂	NC	NC	
21	P4 ₃ /D ₃ ^{*1}	P4 ₃ /D ₃ ^{*2}	P4 ₃ /D ₃ ^{*1}	P4 ₃ /D ₃ ^{*2}	P4 ₃ /D ₃ ^{*1}	P4 ₃ /D ₃ ^{*1}	P4 ₃	NC	NC	
22	V _{ss}	V _{ss}	V _{ss}	V _{ss}	V _{ss}	V _{ss}	V _{ss}	V _{ss}	V _{ss}	

Pin Name

Pin No.	Pin Name							PROM Mode		Remarks
	Mode 1	Mode 2	Mode 3	Mode 4	Mode 5	Mode 6	Mode 7	EPROM	Flash	
23	P4 ₄ /D ₄ ^{*1}	P4 ₄ /D ₄ ^{*2}	P4 ₄ /D ₄ ^{*1}	P4 ₄ /D ₄ ^{*2}	P4 ₄ /D ₄ ^{*1}	P4 ₄ /D ₄ ^{*1}	P4 ₄	NC	NC	
24	P4 ₅ /D ₅ ^{*1}	P4 ₅ /D ₅ ^{*2}	P4 ₅ /D ₅ ^{*1}	P4 ₅ /D ₅ ^{*2}	P4 ₅ /D ₅ ^{*1}	P4 ₅ /D ₅ ^{*1}	P4 ₅	NC	NC	
25	P4 ₆ /D ₆ ^{*1}	P4 ₆ /D ₆ ^{*2}	P4 ₆ /D ₆ ^{*1}	P4 ₆ /D ₆ ^{*2}	P4 ₆ /D ₆ ^{*1}	P4 ₆ /D ₆ ^{*1}	P4 ₆	NC	NC	
26	P4 ₇ /D ₇ ^{*1}	P4 ₇ /D ₇ ^{*2}	P4 ₇ /D ₇ ^{*1}	P4 ₇ /D ₇ ^{*2}	P4 ₇ /D ₇ ^{*1}	P4 ₇ /D ₇ ^{*1}	P4 ₇	NC	NC	
27	D ₈	D ₈	D ₈	D ₈	D ₈	D ₈	P3 ₀	EO ₀	I/O ₀	
28	D ₉	D ₉	D ₉	D ₉	D ₉	D ₉	P3 ₁	EO ₁	I/O ₁	
29	D ₁₀	D ₁₀	D ₁₀	D ₁₀	D ₁₀	D ₁₀	P3 ₂	EO ₂	I/O ₂	
30	D ₁₁	D ₁₁	D ₁₁	D ₁₁	D ₁₁	D ₁₁	P3 ₃	EO ₃	I/O ₃	
31	D ₁₂	D ₁₂	D ₁₂	D ₁₂	D ₁₂	D ₁₂	P3 ₄	EO ₄	I/O ₄	
32	D ₁₃	D ₁₃	D ₁₃	D ₁₃	D ₁₃	D ₁₃	P3 ₅	EO ₅	I/O ₅	
33	D ₁₄	D ₁₄	D ₁₄	D ₁₄	D ₁₄	D ₁₄	P3 ₆	EO ₆	I/O ₆	
34	D ₁₅	D ₁₅	D ₁₅	D ₁₅	D ₁₅	D ₁₅	P3 ₇	EO ₇	I/O ₇	
35	V _{CC}	V _{CC}	V _{CC}	V _{CC}	V _{CC}	V _{CC}	V _{CC}	V _{CC}	V _{CC}	
36	A ₀	A ₀	A ₀	A ₀	P1 ₀ /A ₀	P1 ₀ /A ₀	P1 ₀	EA ₀	A ₀	
37	A ₁	A ₁	A ₁	A ₁	P1 ₁ /A ₁	P1 ₁ /A ₁	P1 ₁	EA ₁	A ₁	
38	A ₂	A ₂	A ₂	A ₂	P1 ₂ /A ₂	P1 ₂ /A ₂	P1 ₂	EA ₂	A ₂	
39	A ₃	A ₃	A ₃	A ₃	P1 ₃ /A ₃	P1 ₃ /A ₃	P1 ₃	EA ₃	A ₃	
40	A ₄	A ₄	A ₄	A ₄	P1 ₄ /A ₄	P1 ₄ /A ₄	P1 ₄	EA ₄	A ₄	
41	A ₅	A ₅	A ₅	A ₅	P1 ₅ /A ₅	P1 ₅ /A ₅	P1 ₅	EA ₅	A ₅	
42	A ₆	A ₆	A ₆	A ₆	P1 ₆ /A ₆	P1 ₆ /A ₆	P1 ₆	EA ₆	A ₆	
43	A ₇	A ₇	A ₇	A ₇	P1 ₇ /A ₇	P1 ₇ /A ₇	P1 ₇	EA ₇	A ₇	
44	V _{SS}	V _{SS}	V _{SS}	V _{SS}	V _{SS}	V _{SS}	V _{SS}	V _{SS}	V _{SS}	
45	A ₈	A ₈	A ₈	A ₈	P2 ₀ /A ₈	P2 ₀ /A ₈	P2 ₀	EA ₈	A ₈	
46	A ₉	A ₉	A ₉	A ₉	P2 ₁ /A ₉	P2 ₁ /A ₉	P2 ₁	\overline{OE}	\overline{OE}	
47	A ₁₀	A ₁₀	A ₁₀	A ₁₀	P2 ₂ /A ₁₀	P2 ₂ /A ₁₀	P2 ₂	EA ₁₀	A ₁₀	
48	A ₁₁	A ₁₁	A ₁₁	A ₁₁	P2 ₃ /A ₁₁	P2 ₃ /A ₁₁	P2 ₃	EA ₁₁	A ₁₁	
49	A ₁₂	A ₁₂	A ₁₂	A ₁₂	P2 ₄ /A ₁₂	P2 ₄ /A ₁₂	P2 ₄	EA ₁₂	A ₁₂	
50	A ₁₃	A ₁₃	A ₁₃	A ₁₃	P2 ₅ /A ₁₃	P2 ₅ /A ₁₃	P2 ₅	EA ₁₃	A ₁₃	
51	A ₁₄	A ₁₄	A ₁₄	A ₁₄	P2 ₆ /A ₁₄	P2 ₆ /A ₁₄	P2 ₆	EA ₁₄	A ₁₄	
52	A ₁₅	A ₁₅	A ₁₅	A ₁₅	P2 ₇ /A ₁₅	P2 ₇ /A ₁₅	P2 ₇	\overline{CE}	\overline{CE}	
53	A ₁₆	A ₁₆	A ₁₆	A ₁₆	P5 ₀ /A ₁₆	P5 ₀ /A ₁₆	P5 ₀	V _{CC}	V _{CC}	
54	A ₁₇	A ₁₇	A ₁₇	A ₁₇	P5 ₁ /A ₁₇	P5 ₁ /A ₁₇	P5 ₁	V _{CC}	V _{CC}	

Pin Name

Pin No.	Pin Name							PROM Mode		Remarks
	Mode 1	Mode 2	Mode 3	Mode 4	Mode 5	Mode 6	Mode 7	EPROM	Flash	
55	A ₁₈	A ₁₈	A ₁₈	A ₁₈	P5 ₂ /A ₁₈	P5 ₂ /A ₁₈	P5 ₂	NC	NC	
56	A ₁₉	A ₁₉	A ₁₉	A ₁₉	P5 ₃ /A ₁₉	P5 ₃ /A ₁₉	P5 ₃	NC	NC	
57	V _{SS}	V _{SS}	V _{SS}	V _{SS}	V _{SS}	V _{SS}	V _{SS}	V _{SS}	V _{SS}	
58	P6 ₀ / WAIT	P6 ₀ / WAIT	P6 ₀ / WAIT	P6 ₀ / WAIT	P6 ₀ / WAIT	P6 ₀ / WAIT	P6 ₀	EA ₁₅	A ₁₅	
59	P6 ₁ / BREQ	P6 ₁ / BREQ	P6 ₁ / BREQ	P6 ₁ / BREQ	P6 ₁ / BREQ	P6 ₁ / BREQ	P6 ₁	NC	NC	
60	P6 ₂ / BACK	P6 ₂ / BACK	P6 ₂ / BACK	P6 ₂ / BACK	P6 ₂ / BACK	P6 ₂ / BACK	P6 ₂	NC	NC	
61	φ	φ	φ	φ	φ	φ	φ	NC	NC	
62	$\overline{\text{STBY}}$	$\overline{\text{STBY}}$	$\overline{\text{STBY}}$	$\overline{\text{STBY}}$	$\overline{\text{STBY}}$	$\overline{\text{STBY}}$	$\overline{\text{STBY}}$	V _{SS}	V _{CC}	
63	$\overline{\text{RES}}$	$\overline{\text{RES}}$	$\overline{\text{RES}}$	$\overline{\text{RES}}$	$\overline{\text{RES}}$	$\overline{\text{RES}}$	$\overline{\text{RES}}$	NC	$\overline{\text{RES}}$	
64	NMI	NMI	NMI	NMI	NMI	NMI	NMI	EA ₉	A ₉	
65	V _{SS}	V _{SS}	V _{SS}	V _{SS}	V _{SS}	V _{SS}	V _{SS}	V _{SS}	V _{SS}	
66	EXTAL	EXTAL	EXTAL	EXTAL	EXTAL	EXTAL	EXTAL	NC	EXTAL	
67	XTAL	XTAL	XTAL	XTAL	XTAL	XTAL	XTAL	NC	XTAL	
68	V _{CC}	V _{CC}	V _{CC}	V _{CC}	V _{CC}	V _{CC}	V _{CC}	V _{CC}	V _{CC}	
69	$\overline{\text{AS}}$	$\overline{\text{AS}}$	$\overline{\text{AS}}$	$\overline{\text{AS}}$	$\overline{\text{AS}}$	$\overline{\text{AS}}$	P6 ₃	NC	A ₁₆	
70	$\overline{\text{RD}}$	$\overline{\text{RD}}$	$\overline{\text{RD}}$	$\overline{\text{RD}}$	$\overline{\text{RD}}$	$\overline{\text{RD}}$	P6 ₄	NC	NC	
71	$\overline{\text{HWR}}$	$\overline{\text{HWR}}$	$\overline{\text{HWR}}$	$\overline{\text{HWR}}$	$\overline{\text{HWR}}$	$\overline{\text{HWR}}$	P6 ₅	NC	V _{CC}	
72	$\overline{\text{LWR}}$	$\overline{\text{LWR}}$	$\overline{\text{LWR}}$	$\overline{\text{LWR}}$	$\overline{\text{LWR}}$	$\overline{\text{LWR}}$	P6 ₆	NC	NC	
73	MD ₀	MD ₀	MD ₀	MD ₀	MD ₀	MD ₀	MD ₀	V _{SS}	V _{SS}	
74	MD ₁	MD ₁	MD ₁	MD ₁	MD ₁	MD ₁	MD ₁	V _{SS}	V _{SS}	
75	MD ₂	MD ₂	MD ₂	MD ₂	MD ₂	MD ₂	MD ₂	V _{SS}	V _{SS}	
76	AV _{CC}	AV _{CC}	AV _{CC}	AV _{CC}	AV _{CC}	AV _{CC}	AV _{CC}	V _{CC}	V _{CC}	
77	V _{REF}	V _{REF}	V _{REF}	V _{REF}	V _{REF}	V _{REF}	V _{REF}	V _{CC}	V _{CC}	
78	P7 ₀ /AN ₀	P7 ₀ /AN ₀	P7 ₀ /AN ₀	P7 ₀ /AN ₀	P7 ₀ /AN ₀	P7 ₀ /AN ₀	P7 ₀ /AN ₀	NC	NC	
79	P7 ₁ /AN ₁	P7 ₁ /AN ₁	P7 ₁ /AN ₁	P7 ₁ /AN ₁	P7 ₁ /AN ₁	P7 ₁ /AN ₁	P7 ₁ /AN ₁	NC	NC	
80	P7 ₂ /AN ₂	P7 ₂ /AN ₂	P7 ₂ /AN ₂	P7 ₂ /AN ₂	P7 ₂ /AN ₂	P7 ₂ /AN ₂	P7 ₂ /AN ₂	NC	NC	
81	P7 ₃ /AN ₃	P7 ₃ /AN ₃	P7 ₃ /AN ₃	P7 ₃ /AN ₃	P7 ₃ /AN ₃	P7 ₃ /AN ₃	P7 ₃ /AN ₃	NC	NC	
82	P7 ₄ /AN ₄	P7 ₄ /AN ₄	P7 ₄ /AN ₄	P7 ₄ /AN ₄	P7 ₄ /AN ₄	P7 ₄ /AN ₄	P7 ₄ /AN ₄	NC	NC	
83	P7 ₅ /AN ₅	P7 ₅ /AN ₅	P7 ₅ /AN ₅	P7 ₅ /AN ₅	P7 ₅ /AN ₅	P7 ₅ /AN ₅	P7 ₅ /AN ₅	NC	NC	

Pin Name

Pin No.	Pin Name							PROM Mode		
	Mode 1	Mode 2	Mode 3	Mode 4	Mode 5	Mode 6	Mode 7	EPROM	Flash	Remarks
84	P7 _e /AN _e / DA ₀	P7 _e /AN _e / DA ₀	P7 _e /AN _e / DA ₀	P7 _e /AN _e / DA ₀	P7 _e /AN _e / DA ₀	P7 _e /AN _e / DA ₀	P7 _e /AN _e / DA ₀	NC	NC	
85	P7 _f /AN _f / DA ₁	P7 _f /AN _f / DA ₁	P7 _f /AN _f / DA ₁	P7 _f /AN _f / DA ₁	P7 _f /AN _f / DA ₁	P7 _f /AN _f / DA ₁	P7 _f /AN _f / DA ₁	NC	NC	
86	AV _{SS}	AV _{SS}	AV _{SS}	AV _{SS}	AV _{SS}	AV _{SS}	AV _{SS}	V _{SS}	V _{SS}	
87	P8 _g / RFSH/ IRQ ₀	P8 _g / RFSH/ IRQ ₀	P8 _g / RFSH/ IRQ ₀	P8 _g / RFSH/ IRQ ₀	P8 _g / RFSH/ IRQ ₀	P8 _g / RFSH/ IRQ ₀	P8 _g / RFSH/ IRQ ₀	P8 _g / RFSH/ IRQ ₀	EA ₁₆	NC
88	P8 _h /CS ₃ / IRQ ₁	P8 _h /CS ₃ / IRQ ₁	P8 _h /CS ₃ / IRQ ₁	P8 _h /CS ₃ / IRQ ₁	P8 _h /CS ₃ / IRQ ₁	P8 _h /CS ₃ / IRQ ₁	P8 _h /CS ₃ / IRQ ₁	P8 _h /IRQ ₁	PGM	NC
89	P8 _i /CS ₂ / IRQ ₂	P8 _i /CS ₂ / IRQ ₂	P8 _i /CS ₂ / IRQ ₂	P8 _i /CS ₂ / IRQ ₂	P8 _i /CS ₂ / IRQ ₂	P8 _i /CS ₂ / IRQ ₂	P8 _i /CS ₂ / IRQ ₂	P8 _i /IRQ ₂	NC	V _{CC}
90	P8 _j /CS ₁ / IRQ ₃	P8 _j /CS ₁ / IRQ ₃	P8 _j /CS ₁ / IRQ ₃	P8 _j /CS ₁ / IRQ ₃	P8 _j /CS ₁ / IRQ ₃	P8 _j /CS ₁ / IRQ ₃	P8 _j /CS ₁ / IRQ ₃	P8 _j /IRQ ₃	NC	WE
91	P8 _k /CS ₀	P8 _k /CS ₀	P8 _k /CS ₀	P8 _k /CS ₀	P8 _k /CS ₀	P8 _k /CS ₀	P8 _k /CS ₀	P8 _k	NC	NC
92	V _{SS}	V _{SS}	V _{SS}	V _{SS}	V _{SS}	V _{SS}	V _{SS}	V _{SS}	V _{SS}	V _{SS}
93	PA ₀ /TP ₀ / TEND ₀ / TCLKA	PA ₀ /TP ₀ / TEND ₀ / TCLKA	PA ₀ /TP ₀ / TEND ₀ / TCLKA	PA ₀ /TP ₀ / TEND ₀ / TCLKA	PA ₀ /TP ₀ / TEND ₀ / TCLKA	PA ₀ /TP ₀ / TEND ₀ / TCLKA	PA ₀ /TP ₀ / TEND ₀ / TCLKA	PA ₀ /TP ₀ / TEND ₀ / TCLKA	NC	NC
94	PA ₁ /TP ₁ / TEND ₁ / TCLKB	PA ₁ /TP ₁ / TEND ₁ / TCLKB	PA ₁ /TP ₁ / TEND ₁ / TCLKB	PA ₁ /TP ₁ / TEND ₁ / TCLKB	PA ₁ /TP ₁ / TEND ₁ / TCLKB	PA ₁ /TP ₁ / TEND ₁ / TCLKB	PA ₁ /TP ₁ / TEND ₁ / TCLKB	PA ₁ /TP ₁ / TEND ₁ / TCLKB	NC	NC
95	PA ₂ /TP ₂ / TIOCA ₀ / TCLKC	PA ₂ /TP ₂ / TIOCA ₀ / TCLKC	PA ₂ /TP ₂ / TIOCA ₀ / TCLKC	PA ₂ /TP ₂ / TIOCA ₀ / TCLKC	PA ₂ /TP ₂ / TIOCA ₀ / TCLKC	PA ₂ /TP ₂ / TIOCA ₀ / TCLKC	PA ₂ /TP ₂ / TIOCA ₀ / TCLKC	PA ₂ /TP ₂ / TIOCA ₀ / TCLKC	NC	NC
96	PA ₃ /TP ₃ / TIOCB ₀ / TCLKD	PA ₃ /TP ₃ / TIOCB ₀ / TCLKD	PA ₃ /TP ₃ / TIOCB ₀ / TCLKD	PA ₃ /TP ₃ / TIOCB ₀ / TCLKD	PA ₃ /TP ₃ / TIOCB ₀ / TCLKD	PA ₃ /TP ₃ / TIOCB ₀ / TCLKD	PA ₃ /TP ₃ / TIOCB ₀ / TCLKD	PA ₃ /TP ₃ / TIOCB ₀ / TCLKD	NC	NC
97	PA ₄ /TP ₄ / TIOCA ₁ / CS ₆	PA ₄ /TP ₄ / TIOCA ₁ / CS ₆	PA ₄ /TP ₄ / TIOCA ₁ / CS ₆	PA ₄ /TP ₄ / TIOCA ₁ / CS ₆	PA ₄ /TP ₄ / TIOCA ₁ / CS ₆	PA ₄ /TP ₄ / TIOCA ₁ / CS ₆	PA ₄ /TP ₄ / TIOCA ₁ / CS ₆	PA ₄ /TP ₄ / TIOCA ₁ / CS ₆	NC	NC
98	PA ₅ /TP ₅ / TIOCB ₁ / CS ₅	PA ₅ /TP ₅ / TIOCB ₁ / CS ₅	PA ₅ /TP ₅ / TIOCB ₁ / CS ₅	PA ₅ /TP ₅ / TIOCB ₁ / CS ₅	PA ₅ /TP ₅ / TIOCB ₁ / CS ₅	PA ₅ /TP ₅ / TIOCB ₁ / CS ₅	PA ₅ /TP ₅ / TIOCB ₁ / CS ₅	PA ₅ /TP ₅ / TIOCB ₁ / CS ₅	NC	NC
99	PA ₆ /TP ₆ / TIOCA ₂ / CS ₄	PA ₆ /TP ₆ / TIOCA ₂ / CS ₄	PA ₆ /TP ₆ / TIOCA ₂ / CS ₄	PA ₆ /TP ₆ / TIOCA ₂ / CS ₄	PA ₆ /TP ₆ / TIOCA ₂ / CS ₄	PA ₆ /TP ₆ / TIOCA ₂ / CS ₄	PA ₆ /TP ₆ / TIOCA ₂ / CS ₄	PA ₆ /TP ₆ / TIOCA ₂ / CS ₄	NC	NC
100	PA ₇ /TP ₇ / TIOCB ₂	PA ₇ /TP ₇ / TIOCB ₂	A ₂₀	A ₂₀	PA ₇ /TP ₇ / TIOCB ₂	A ₂₀	PA ₇ /TP ₇ / TIOCB ₂	NC	NC	

Notes: Pins marked NC should be left unconnected.

For details on PROM mode see section 18, ROM (H8/3048F-ONE: Single Power Supply, H8/3048B Mask ROM Version).

1. In modes 1, 3, 5, and 6 the $P4_0$ to $P4_7$ functions of pins $P4_0/D_0$ to $P4_7/D_7$ are selected after a reset, but they can be changed by software.
2. In modes 2 and 4 the D_0 to D_7 functions of pins $P4_0/D_0$ to $P4_7/D_7$ are selected after a reset, but they can be changed by software.
3. For the H8/3048B Group which operates at 5 V, this pin is also used as the V_{cl} terminal, and for those at 3 V, V_{cc} terminal. For the H8/3048 ZTAT version, H8/3048F version, H8/3048 mask ROM version, H8/3047 mask ROM version, H8/3045 mask ROM version, and H8/3044 mask ROM version, this pin is also used as the V_{cc} terminal.
4. This pin functions as the FWE pin on the single power supply on-chip flash memory version. Under no circumstances should 12 V be applied to the single power supply on-chip flash memory version (H8/3048F-ONE), or to H8/3048 Group or H8/3048B Group mask ROM products. Doing so will destroy the chip. This pin functions as an overview control signal in modes 5, 6, and 7. The pin functions as the \overline{RESO} pin in on-chip mask ROM versions, on-chip PROM versions, and dual power supply flash memory versions.

1.3.3 Pin Functions

Table 1.4 summarizes the pin functions. For the H8/3048B Group which operates at 5 V, the external capacitor is required for the V_{CL} pin.

Table 1.4 Pin Functions

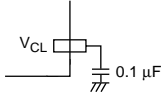
Type	Symbol	Pin No.	I/O	Name and Function
Power	V_{CC}	1*1, 35, 68	Input	Power: For connection to the power supply. Connect all V_{CC} pins to the system power supply.
	V_{SS}	11, 22, 44, 57, 65, 92	Input	Ground: For connection to ground (0 V). Connect all V_{SS} pins to the 0-V system power supply.
Internal step-down pin	V_{CL}	1*2	Output	The external capacitor must be connected between the V_{CL} and GND (0 V). Do not connect to V_{CC} . 
Clock	XTAL	67	Input	For connection to a crystal resonator. For examples of crystal resonator and external clock input, see section 19, Clock Pulse Generator.
	EXTAL	66	Input	For connection to a crystal resonator or input of an external clock signal. For examples of crystal resonator and external clock input, see section 19, Clock Pulse Generator.
	ϕ	61	Output	System clock: Supplies the system clock to external devices.

Type	Symbol	Pin No.	I/O	Name and Function			
Operating mode control	MD ₂ to MD ₀	75 to 73	Input	Mode 2 to mode 0: For setting the operating mode, as follows. Inputs at these pins must not be changed during operation.			
				MD₂	MD₁	MD₀	Operating Mode
				0	0	0	—
				0	0	1	Mode 1
				0	1	0	Mode 2
				0	1	1	Mode 3
				1	0	0	Mode 4
				1	0	1	Mode 5
				1	1	0	Mode 6
				1	1	1	Mode 7
System control	$\overline{\text{RES}}$	63	Input	Reset input: When driven low, this pin resets the chip			
	$\overline{\text{RESO}}$	10	Output	Reset output: For the mask ROM version, outputs a reset signal to external devices Also used as a power supply for on-board programming of the flash memory version with dual power supply.			
	$(\overline{\text{RESO}}/V_{\text{PP}})$						
	FWE ^{*3}	10	Input	Write enable signal: Write-control signal for writing to flash memory for the flash memory version with single power supply			
	$\overline{\text{STBY}}$	62	Input	Standby: When driven low, this pin forces a transition to hardware standby mode			
	$\overline{\text{BREQ}}$	59	Input	Bus request: Used by an external bus master to request the bus right			
Interrupts	$\overline{\text{BACK}}$	60	Output	Bus request acknowledge: Indicates that the bus has been granted to an external bus master			
	NMI	64	Input	Nonmaskable interrupt: Requests a nonmaskable interrupt			
	$\overline{\text{IRQ}}_5$ to $\overline{\text{IRQ}}_0$	17, 16, 90 to 87	Input	Interrupt request 5 to 0: Maskable interrupt request pins			
Address bus	A ₂₃ to A ₀	97 to 100, 56 to 45, 43 to 36	Output	Address bus: Outputs address signals			
Data bus	D ₁₅ to D ₀	34 to 23, 21 to 18	Input/output	Data bus: Bidirectional data bus			

Type	Symbol	Pin No.	I/O	Name and Function
Bus control	\overline{CS}_7 to \overline{CS}_0	8, 97 to 99, 88 to 91	Output	Chip select: Select signals for areas 7 to 0
	\overline{AS}	69	Output	Address strobe: Goes low to indicate valid address output on the address bus
	\overline{RD}	70	Output	Read: Goes low to indicate reading from the external address space
	\overline{HWR}	71	Output	High write: Goes low to indicate writing to the external address space; indicates valid data on the upper data bus (D_{15} to D_8).
	\overline{LWR}	72	Output	Low write: Goes low to indicate writing to the external address space; indicates valid data on the lower data bus (D_7 to D_0).
	\overline{WAIT}	58	Input	Wait: Requests insertion of wait states in bus cycles during access to the external address space
Refresh controller	\overline{RFSH}	87	Output	Refresh: Indicates a refresh cycle
	\overline{CS}_3	88	Output	Row address strobe \overline{RAS}: Row address strobe signal for DRAM connected to area 3
	\overline{RD}	70	Output	Column address strobe \overline{CAS}: Column address strobe signal for DRAM connected to area 3; used with $2\overline{WE}$ DRAM. Write enable \overline{WE}: Write enable signal for DRAM connected to area 3; used with $2\overline{CAS}$ DRAM.
	\overline{HWR}	71	Output	Upper write \overline{UW}: Write enable signal for DRAM connected to area 3; used with $2\overline{WE}$ DRAM. Upper column address strobe \overline{UCAS}: Column address strobe signal for DRAM connected to area 3; used with $2\overline{CAS}$ DRAM.
	\overline{LWR}	72	Output	Lower write \overline{LW}: Write enable signal for DRAM connected to area 3; used with $2\overline{WE}$ DRAM. Lower column address strobe \overline{LCAS}: Column address strobe signal for DRAM connected to area 3; used with $2\overline{CAS}$ DRAM.

Type	Symbol	Pin No.	I/O	Name and Function
DMA controller (DMAC)	$\overline{\text{DREQ}}_1$, $\overline{\text{DREQ}}_0$	9, 8	Input	DMA request 1 and 0: DMAC activation requests
	$\overline{\text{TEND}}_1$, $\overline{\text{TEND}}_0$	94, 93	Output	Transfer end 1 and 0: These signals indicate that the DMAC has ended a data transfer
16-bit integrated timer unit (ITU)	TCLKD to TCLKA	96 to 93	Input	Clock input D to A: External clock inputs
	TIOCA ₄ to TIOCA ₀	4, 2, 99, 97, 95	Input/ output	Input capture/output compare A4 to A0: GRA4 to GRA0 output compare or input capture, or PWM output
	TIOCB ₄ to TIOCB ₀	5, 3, 100, 98, 96	Input/ output	Input capture/output compare B4 to B0: GRB4 to GRB0 output compare or input capture
	TOCX _{A4}	6	Output	Output compare XA4: PWM output
	TOCX _{B4}	7	Output	Output compare XB4: PWM output
Programmable timing pattern controller (TPC)	TP ₁₅ to TP ₀	9 to 2, 100 to 93	Output	TPC output 15 to 0: Pulse output
Serial communication interface (SCI)	TxD ₁ , TxD ₀	13, 12	Output	Transmit data (channels 0 and 1): SCI data output
	RxD ₁ , RxD ₀	15, 14	Input	Receive data (channels 0 and 1): SCI data input
	SCK ₁ , SCK ₀	17, 16	Input/ output	Serial clock (channels 0 and 1): SCI clock input/output
A/D converter	AN ₇ to AN ₀	85 to 78	Input	Analog 7 to 0: Analog input pins
	$\overline{\text{ADTRG}}$	9	Input	A/D trigger: External trigger input for starting A/D conversion
D/A converter	DA ₁ , DA ₀	85, 84	Output	Analog output: Analog output from the D/A converter
A/D and D/A converters	AV _{cc}	76	Input	Power supply pin for the A/D and D/A converters. Connect to the system power supply (V _{cc}) when not using the A/D and D/A converters.
	AV _{ss}	86	Input	Ground pin for the A/D and D/A converters. Connect to system ground (V _{ss}).

Type	Symbol	Pin No.	I/O	Name and Function
A/D and D/A converters	V_{REF}	77	Input	Reference voltage input pin for the A/D and D/A converters. Connect to the system power supply (V_{CC}) when not using the A/D and D/A converters.
I/O ports	$P1_7$ to $P1_0$	43 to 36	Input/output	Port 1: Eight input/output pins. The direction of each pin can be selected in the port 1 data direction register (P1DDR).
	$P2_7$ to $P2_0$	52 to 45	Input/output	Port 2: Eight input/output pins. The direction of each pin can be selected in the port 2 data direction register (P2DDR).
	$P3_7$ to $P3_0$	34 to 27	Input/output	Port 3: Eight input/output pins. The direction of each pin can be selected in the port 3 data direction register (P3DDR).
	$P4_7$ to $P4_0$	26 to 23, 21 to 18	Input/output	Port 4: Eight input/output pins. The direction of each pin can be selected in the port 4 data direction register (P4DDR).
	$P5_3$ to $P5_0$	56 to 53	Input/output	Port 5: Four input/output pins. The direction of each pin can be selected in the port 5 data direction register (P5DDR).
	$P6_6$ to $P6_0$	72 to 69, 60 to 58	Input/output	Port 6: Seven input/output pins. The direction of each pin can be selected in the port 6 data direction register (P6DDR).
	$P7_7$ to $P7_0$	85 to 78	Input	Port 7: Eight input pins
	$P8_4$ to $P8_0$	91 to 87	Input/output	Port 8: Five input/output pins. The direction of each pin can be selected in the port 8 data direction register (P8DDR).
	$P9_5$ to $P9_0$	17 to 12	Input/output	Port 9: Six input/output pins. The direction of each pin can be selected in the port 9 data direction register (P9DDR).
	PA_7 to PA_0	100 to 93	Input/output	Port A: Eight input/output pins. The direction of each pin can be selected in the port A data direction register (PADDDR).
PB_7 to PB_0	9 to 2	Input/output	Port B: Eight input/output pins. The direction of each pin can be selected in the port B data direction register (PBDDR).	

- Notes:
1. For H8/3048 Group products and H8/3048B Group models operating at 3 V.
 2. For the H8/3048B Group which operates at 5 V.
 3. Do NOT apply 12 V to the H8/3048B Group as the chip will be destroyed.

1.4 Notes on H8/3048F-ONE (Single Power Supply)

There are two models of the H8/3048F-ZTAT with on-chip flash memory: a dual power supply model (H8/3048F) and single power supply model (H8/3048F-ONE). Points to be noted when using the single power supply H8/3048F-ONE are given below.

1.4.1 Voltage Application

12 V must not be applied to the H8/3048F-ONE (single power supply), as this will permanently damage the device.

The flash memory programming power source for the H8/3048F-ONE (single power supply) is V_{CC} .

The programming power source for the dual power supply model was the V_{PP} pin (12 V), but there is no V_{PP} pin in the single power supply models. In the H8/3048F-ONE the FWE pin is provided at the same pin position as the V_{PP} pin in the dual power supply model, but FWE is not a power source pin-it is used to control flash memory write enabling.

Also, in boot mode, 12 V must be applied to the MD_2 pin in the dual power supply model, but this is not necessary in the H8/3048F-ONE (single power supply).

The maximum rating of the FWE and MD_2 pins in the H8/3048F-ONE (single power supply) is $V_{CC} + 0.3$ V. Applying a voltage in excess of the maximum rating will permanently damage the device.

Do not select the HN28F101 programmer setting for the H8/3048F-ONE (single power supply). If this setting is made by mistake, 12.0 V may be applied to the FWE pin, causing permanent damage to the device.

When using a PROM programmer to program the on-chip flash memory in the H8/3048F-ONE model (single power supply), use a PROM programmer that supports Renesas Technology microcomputer device types with 128-kbyte on-chip flash memory.

1.4.2 Product Type Names and Markings

Table 1.5 shows examples of product type names and markings for the H8/3048F (dual power supply model), H8/3048F-ONE (single power supply), and the differences in flash memory programming power source.

Table 1.5 Differences in H8/3048F and H8/3048F-ONE

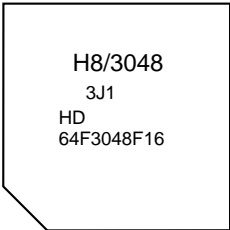
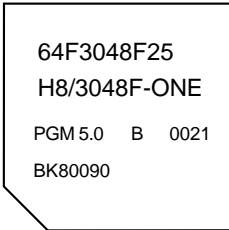
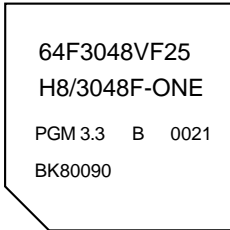
	Dual Power Supply Model: H8/3048F	Single Power Supply Model: H8/3048F-ONE	
Product type name	HD64F3048F16	HD64F3048BF25	HD64F3048BVF25
Sample markings			
Flash memory programming power source	V_{PP} power source (12.0 \pm 0.6 V)	V_{CC} power source (5.0 \pm 10%)	V_{CC} power source (3.0 to 3.6 V)

1.4.3 Differences between H8/3048F and H8/3048F-ONE

Table 1.6 shows the differences between the H8/3048F (dual power supply model) and H8/3048F-ONE (single power supply model).

Table 1.6 Differences between H8/3048F and H8/3048F-ONE

Item	Models with Dual Power Supply: H8/3048F ^{※1}	Models with Single Power Supply: H8/3048F-ONE																															
Pin specifications	Pin 1: V_{CC}	Pin 1: V_{CL} (when a model which operates at 5 V is used) Connected to V_{SS} with 0.1 μ F externally applied. Pin 1 becomes V_{CC} when a model which operates at 3 V is used.																															
	Pin 10: V_{PP}/\overline{RESO}	Pin 10: FWE																															
ROM/RAM	128-kbyte flash memory with dual power supply, RAM: 4 kbytes	128-kbyte flash memory with single power supply, RAM: 4 kbytes																															
Units of on-board writing	Writing in 1-byte units	Writing in 128-byte units																															
Write/erase voltage	12 V is externally applied from V_{PP} pin	Application of 12 V is not required. V_{CC} single power supply																															
V_{PP} pin functions	Multiplexes with \overline{RESO}	FWE function only (no RESO function)																															
Boot mode settings	$\overline{RESO} = 12$ V	FWE = 1																															
	<table border="1"> <thead> <tr> <th></th> <th>MD2</th> <th>MD1</th> <th>MD0</th> </tr> </thead> <tbody> <tr> <td>Mode 5</td> <td>12 V</td> <td>0</td> <td>1</td> </tr> <tr> <td>Mode 6</td> <td>12 V</td> <td>1</td> <td>0</td> </tr> <tr> <td>Mode 7</td> <td>12 V</td> <td>1</td> <td>1</td> </tr> </tbody> </table> <p>Cancelled by reset</p>		MD2	MD1	MD0	Mode 5	12 V	0	1	Mode 6	12 V	1	0	Mode 7	12 V	1	1	<table border="1"> <thead> <tr> <th></th> <th>MD2</th> <th>MD1</th> <th>MD0</th> </tr> </thead> <tbody> <tr> <td>Mode 5</td> <td>0</td> <td>0</td> <td>1</td> </tr> <tr> <td>Mode 6</td> <td>0</td> <td>1</td> <td>0</td> </tr> <tr> <td>Mode 7</td> <td>0</td> <td>1</td> <td>1</td> </tr> </tbody> </table> <p>Set to mode 1 in mode 5 Set to mode 2 in mode 6 Set to mode 3 in mode 7 Cancelled by reset</p>		MD2	MD1	MD0	Mode 5	0	0	1	Mode 6	0	1	0	Mode 7	0	1
	MD2	MD1	MD0																														
Mode 5	12 V	0	1																														
Mode 6	12 V	1	0																														
Mode 7	12 V	1	1																														
	MD2	MD1	MD0																														
Mode 5	0	0	1																														
Mode 6	0	1	0																														
Mode 7	0	1	1																														
Settings for user program mode	$\overline{RESO} = 12$ V	FWE = 1																															
	<table border="1"> <thead> <tr> <th></th> <th>MD2</th> <th>MD1</th> <th>MD0</th> </tr> </thead> <tbody> <tr> <td>Mode 5</td> <td>1</td> <td>0</td> <td>1</td> </tr> <tr> <td>Mode 6</td> <td>1</td> <td>1</td> <td>0</td> </tr> <tr> <td>Mode 7</td> <td>1</td> <td>1</td> <td>1</td> </tr> </tbody> </table> <p>Cancelled by reset</p>		MD2	MD1	MD0	Mode 5	1	0	1	Mode 6	1	1	0	Mode 7	1	1	1	<table border="1"> <thead> <tr> <th></th> <th>MD2</th> <th>MD1</th> <th>MD0</th> </tr> </thead> <tbody> <tr> <td>Mode 5</td> <td>1</td> <td>0</td> <td>1</td> </tr> <tr> <td>Mode 6</td> <td>1</td> <td>1</td> <td>0</td> </tr> <tr> <td>Mode 7</td> <td>1</td> <td>1</td> <td>1</td> </tr> </tbody> </table> <p>Cancelled by reset</p>		MD2	MD1	MD0	Mode 5	1	0	1	Mode 6	1	1	0	Mode 7	1	1
	MD2	MD1	MD0																														
Mode 5	1	0	1																														
Mode 6	1	1	0																														
Mode 7	1	1	1																														
	MD2	MD1	MD0																														
Mode 5	1	0	1																														
Mode 6	1	1	0																														
Mode 7	1	1	1																														
Prewrite processing	Necessary before erasing	Not necessary																															
Erasing blocks	More than one block can be erased at the same time (verifies in block units and erases only the unerased blocks)	Erases in one block units. More than one block cannot be erased at the same time (the erasing flow is different)																															

Item	Models with Dual Power Supply: H8/3048F*1	Models with Single Power Supply: H8/3048F-ONE																								
Write processing	Before writing, sets the block with the address to be written to EBR1/EBR2	No setting																								
FLMCR	FLMCR (H'FF40) <table border="1"> <tr> <td>V_{PP}</td> <td>V_{PP}E</td> <td>—</td> <td>—</td> <td>EV</td> <td>PV</td> <td>E</td> <td>P</td> </tr> </table>	V _{PP}	V _{PP} E	—	—	EV	PV	E	P	FLMCR1 (H'FF40) <table border="1"> <tr> <td>FWE</td> <td>SWE</td> <td>ESU</td> <td>PSU</td> <td>EV</td> <td>PV</td> <td>E</td> <td>P</td> </tr> </table> FLMCR2 (H'FF41) <table border="1"> <tr> <td>FLER</td> <td>—</td> <td>—</td> <td>—</td> <td>—</td> <td>—</td> <td>—</td> <td>—</td> </tr> </table>	FWE	SWE	ESU	PSU	EV	PV	E	P	FLER	—	—	—	—	—	—	—
V _{PP}	V _{PP} E	—	—	EV	PV	E	P																			
FWE	SWE	ESU	PSU	EV	PV	E	P																			
FLER	—	—	—	—	—	—	—																			
EBR	EBR1 (H'FF42) <table border="1"> <tr> <td>LB7</td> <td>LB6</td> <td>LB5</td> <td>LB4</td> <td>LB3</td> <td>LB2</td> <td>LB1</td> <td>LB0</td> </tr> </table> EBR2 (H'FF43) <table border="1"> <tr> <td>SB7</td> <td>SB6</td> <td>SB5</td> <td>SB4</td> <td>SB3</td> <td>SB2</td> <td>SB1</td> <td>SB0</td> </tr> </table> More than one block can be selected (setting for writing/erasing)	LB7	LB6	LB5	LB4	LB3	LB2	LB1	LB0	SB7	SB6	SB5	SB4	SB3	SB2	SB1	SB0	EBR (H'FF42) <table border="1"> <tr> <td>EB7</td> <td>EB6</td> <td>EB5</td> <td>EB4</td> <td>EB3</td> <td>EB2</td> <td>EB1</td> <td>EB0</td> </tr> </table> Only one block can be selected(setting for erasing)	EB7	EB6	EB5	EB4	EB3	EB2	EB1	EB0
LB7	LB6	LB5	LB4	LB3	LB2	LB1	LB0																			
SB7	SB6	SB5	SB4	SB3	SB2	SB1	SB0																			
EB7	EB6	EB5	EB4	EB3	EB2	EB1	EB0																			
RAMCR	RAMCR (H'FF48) <table border="1"> <tr> <td>FLER</td> <td>—</td> <td>—</td> <td>—</td> <td>RAMS</td> <td>RAM2</td> <td>RAM1</td> <td>RAM0</td> </tr> </table>	FLER	—	—	—	RAMS	RAM2	RAM1	RAM0	RAMCR (H'FF47) <table border="1"> <tr> <td>—</td> <td>—</td> <td>—</td> <td>—</td> <td>RAMS</td> <td>RAM2</td> <td>RAM1</td> <td>—</td> </tr> </table>	—	—	—	—	RAMS	RAM2	RAM1	—								
FLER	—	—	—	RAMS	RAM2	RAM1	RAM0																			
—	—	—	—	RAMS	RAM2	RAM1	—																			
Division of flash memory block	Division in 16 blocks 16 kbytes × 7: LB0 to LB6 12 kbytes × 1: LB7 512 kbytes × 8: SB0 to SB7	Division in 8 blocks 1 kbyte × 4: EB0 to EB3 28 kbytes × 1: EB4 32 kbytes × 3: EB5 to EB7																								
	Flash memory <table border="1"> <tr><td>LB0 (16 kbytes)</td></tr> <tr><td>LB1 (16 kbytes)</td></tr> <tr><td>LB2 (16 kbytes)</td></tr> <tr><td>LB3 (16 kbytes)</td></tr> <tr><td>LB4 (16 kbytes)</td></tr> <tr><td>LB5 (16 kbytes)</td></tr> <tr><td>LB6 (16 kbytes)</td></tr> <tr><td>LB7 (12 kbytes)</td></tr> <tr><td>SB0 (512 bytes)</td></tr> <tr><td>SB1 (512 bytes)</td></tr> <tr><td>SB2 (512 bytes)</td></tr> <tr><td>SB3 (512 bytes)</td></tr> <tr><td>SB4 (512 bytes)</td></tr> <tr><td>SB5 (512 bytes)</td></tr> <tr><td>SB6 (512 bytes)</td></tr> <tr><td>SB7 (512 bytes)</td></tr> </table> H'00000 H'1FFFF	LB0 (16 kbytes)	LB1 (16 kbytes)	LB2 (16 kbytes)	LB3 (16 kbytes)	LB4 (16 kbytes)	LB5 (16 kbytes)	LB6 (16 kbytes)	LB7 (12 kbytes)	SB0 (512 bytes)	SB1 (512 bytes)	SB2 (512 bytes)	SB3 (512 bytes)	SB4 (512 bytes)	SB5 (512 bytes)	SB6 (512 bytes)	SB7 (512 bytes)	Flash memory <table border="1"> <tr><td>EB0 (1 kbyte)</td></tr> <tr><td>EB1 (1 kbyte)</td></tr> <tr><td>EB2 (1 kbyte)</td></tr> <tr><td>EB3 (1 kbyte)</td></tr> <tr><td>EB4 (28 kbytes)</td></tr> <tr><td>EB5 (32 kbytes)</td></tr> <tr><td>EB6 (32 kbytes)</td></tr> <tr><td>EB7 (32 kbytes)</td></tr> </table> H'00000 H'1FFFF	EB0 (1 kbyte)	EB1 (1 kbyte)	EB2 (1 kbyte)	EB3 (1 kbyte)	EB4 (28 kbytes)	EB5 (32 kbytes)	EB6 (32 kbytes)	EB7 (32 kbytes)
LB0 (16 kbytes)																										
LB1 (16 kbytes)																										
LB2 (16 kbytes)																										
LB3 (16 kbytes)																										
LB4 (16 kbytes)																										
LB5 (16 kbytes)																										
LB6 (16 kbytes)																										
LB7 (12 kbytes)																										
SB0 (512 bytes)																										
SB1 (512 bytes)																										
SB2 (512 bytes)																										
SB3 (512 bytes)																										
SB4 (512 bytes)																										
SB5 (512 bytes)																										
SB6 (512 bytes)																										
SB7 (512 bytes)																										
EB0 (1 kbyte)																										
EB1 (1 kbyte)																										
EB2 (1 kbyte)																										
EB3 (1 kbyte)																										
EB4 (28 kbytes)																										
EB5 (32 kbytes)																										
EB6 (32 kbytes)																										
EB7 (32 kbytes)																										

Item	Models with Dual Power Supply: H8/3048F ^{*1}	Models with Single Power Supply: H8/3048F-ONE
Division of RAM emulation block	<p>On-chip RAM</p> <p>Flash memory</p>	<p>On-chip RAM</p> <p>Flash memory</p>
Reset during operation	The RES signal must be kept low during at least 6 system clock (6φ) cycles. (RES pulse width $t_{RESW} = \text{min. } 6.0 t_{cyc}$)	The RES signal must be kept low during at least 20 system clock (20φ) cycles. (RES pulse width $t_{RESW} = \text{min. } 20 t_{cyc}$)
A/D ADCR	ADCR (H'FFE9) Initial value: H'7F Only bit 7 can be read or written. Other bits are reserved and always read as 1; writing to these bits is invalid.	ADCR (H'FFE9) Initial value: H'7E Only bit 7 can be read or written. Bit 0 is reserved and must not be set to 1. Other bits are reserved and always read as 1; writing to these bits is invalid.
WDT RSTCSR	RSTCSR (H'FFAB) Initial value: H'3F Only bits 7 and 6 can be read or written. Other bits are reserved and always read as 1; writing to these bits is invalid.	RSTCSR (H'FFAB) Initial value: H'3F Only bit 7 can be read or written. Bit 6 is reserved and must not be set to 1. Other bits are reserved and always read as 1; writing to these bits is invalid.

Item	Models with Dual Power Supply: H8/3048F ^{*1}	Models with Single Power Supply: H8/3048F-ONE																																																				
Clock oscillator settling time (SYSCR STS2 to STS0)	Setting of standby timer select bits 2 to 0 <table border="1"> <thead> <tr> <th>STS2</th> <th>STS1</th> <th>STS0</th> <th>Description</th> </tr> </thead> <tbody> <tr> <td rowspan="4">0</td> <td rowspan="2">0</td> <td>0</td> <td>8,192 states</td> </tr> <tr> <td>1</td> <td>16,384 states</td> </tr> <tr> <td rowspan="2">1</td> <td>0</td> <td>32,768 states</td> </tr> <tr> <td>1</td> <td>65,536 states</td> </tr> <tr> <td rowspan="3">1</td> <td rowspan="2">0</td> <td>0</td> <td>131,072 states</td> </tr> <tr> <td>1</td> <td>1,024 states</td> </tr> <tr> <td>1</td> <td>—</td> <td>Illegal setting</td> </tr> </tbody> </table>	STS2	STS1	STS0	Description	0	0	0	8,192 states	1	16,384 states	1	0	32,768 states	1	65,536 states	1	0	0	131,072 states	1	1,024 states	1	—	Illegal setting	Setting of standby timer select bits 2 to 0 <table border="1"> <thead> <tr> <th>STS2</th> <th>STS1</th> <th>STS0</th> <th>Description</th> </tr> </thead> <tbody> <tr> <td rowspan="4">0</td> <td rowspan="2">0</td> <td>0</td> <td>8,192 states</td> </tr> <tr> <td>1</td> <td>16,384 states</td> </tr> <tr> <td rowspan="2">1</td> <td>0</td> <td>32,768 states</td> </tr> <tr> <td>1</td> <td>65,536 states</td> </tr> <tr> <td rowspan="3">1</td> <td rowspan="2">0</td> <td>0</td> <td>131,072 states</td> </tr> <tr> <td>1</td> <td>262,144 states</td> </tr> <tr> <td>1</td> <td>0</td> <td>1,024 states</td> </tr> <tr> <td></td> <td></td> <td>1</td> <td>Illegal setting</td> </tr> </tbody> </table>	STS2	STS1	STS0	Description	0	0	0	8,192 states	1	16,384 states	1	0	32,768 states	1	65,536 states	1	0	0	131,072 states	1	262,144 states	1	0	1,024 states			1	Illegal setting
STS2	STS1	STS0	Description																																																			
0	0	0	8,192 states																																																			
		1	16,384 states																																																			
	1	0	32,768 states																																																			
		1	65,536 states																																																			
1	0	0	131,072 states																																																			
		1	1,024 states																																																			
	1	—	Illegal setting																																																			
STS2	STS1	STS0	Description																																																			
0	0	0	8,192 states																																																			
		1	16,384 states																																																			
	1	0	32,768 states																																																			
		1	65,536 states																																																			
1	0	0	131,072 states																																																			
		1	262,144 states																																																			
	1	0	1,024 states																																																			
		1	Illegal setting																																																			
Details on flash memory	Refer to section 19, Flash Memory (H8/3048F, Dual Power Supply).	Refer to section 18, ROM (H8/3048F-ONE: Single Power Supply, H8/3048B Mask ROM Version)																																																				
Electrical characteristics (clock rate)	Clock rate: 1 to 16 MHz Refer to section 22, Table 22.1 Electrical Characteristics of H8/3048 Group Products. ^{*2}	Clock rate: 2 to 25 MHz Refer to section 21, Table 21.1 Electrical Characteristics of H8/3048 Group and H8/3048B Group Products.																																																				
List of registers	Refer to appendix B, Table B.1 Comparison of H8/3048 Group Internal I/O Register Specifications ^{*2} Refer to appendix B.2, Addresses (For H8/3048F, H8/3048ZTAT, H8/3048 Mask-ROM, H8/3047 Mask-ROM, H8/3045 Mask-ROM, and H8/3044 Mask-ROM Versions) ^{*2}	Refer to appendix B, Table B.1 Comparison of H8/3048 Group Internal I/O Register Specifications ^{*2} Refer to appendix B.1, Addresses (For H8/3048F-ONE, H8/3048B Mask ROM Version) ^{*2}																																																				
On-chip emulator	—	On-chip emulator (E10T)																																																				

- Notes: 1. Refer to the "H8/3048 Group, H8/3048F-ZTAT™ Hardware Manual" for information about H8/3048F.
2. H8/3048F and H8/3048F-ONE can be referred to also on this manual.

1.4.4 V_{CL} Pin

The H8/3048B Group 5 V operation models have a V_{CL} (internal step-down) pin, to which a 0.1 μF internal voltage stabilization capacitor must be connected.

The method of connecting the external capacitor is shown in figure 1.4.

Do not connect the V_{CC} power supply to the V_{CL} pin. (Connect the V_{CC} power supply to other V_{CC} pins as usual.) Note that the V_{CL} output pin occupies the same location as a V_{CC} pin in the H8/3048F, H8/3048ZTAT and on-chip mask ROM models (H8/3048, H8/3047, H8/3045, and H8/3044).

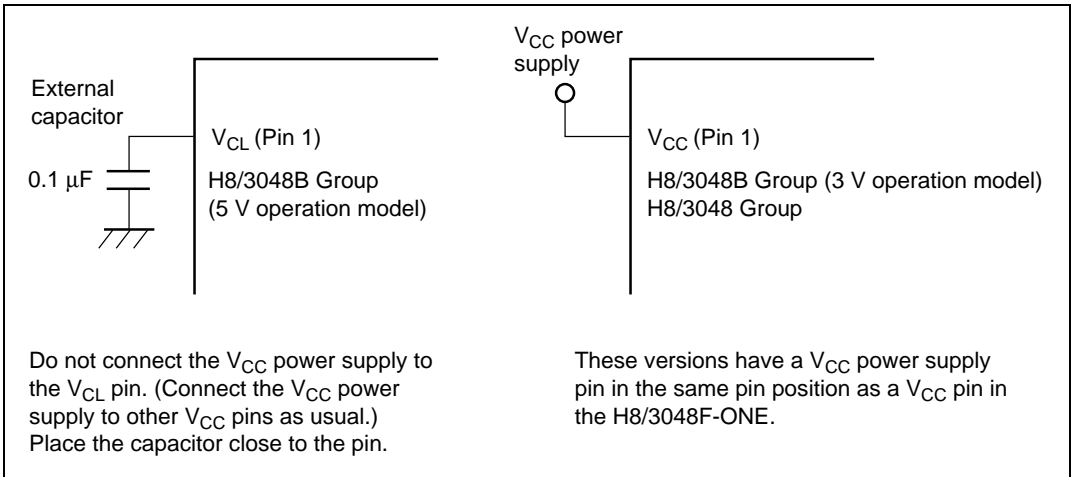

Figure 1.4 Method of Connecting H8/3048B Group V_{CL} Capacitor

The 3 V operation models of the H8/3048B Group do not have a V_{CL} pin. The 3 V operation models have a V_{CC} power supply pin at the location of the V_{CL} pin in the 5 V operation models. Therefore, 3 V operation models do not require connection of an external capacitor, and this pin should be connected to the power supply in the same way as other V_{CC} pins.

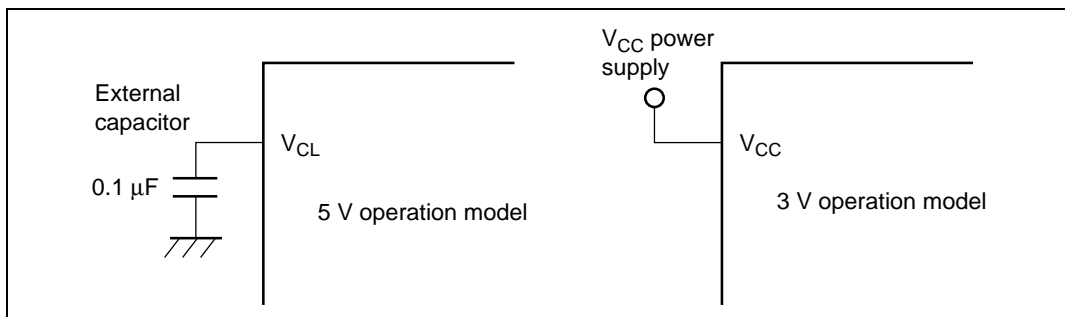

Figure 1.5 Difference between 5 V and 3 V Operation Models

1.4.5 Note on Changeover to H8/3048 Group Mask ROM Version

Care is required when changing from the H8/3048F-ONE with on-chip flash memory to a model with on-chip H8/3048 Group mask ROM (H8/3048, H8/3047, H8/3045, or H8/3044).

An external capacitor must be connected to the V_{CL} pin of the H8/3048F-ONE (5 V model). This V_{CL} pin occupies the same location as a V_{CC} pin in the on-chip mask ROM versions. Changeover to a mask ROM version must therefore be taken into account when undertaking pattern design, etc., in the board design stage.

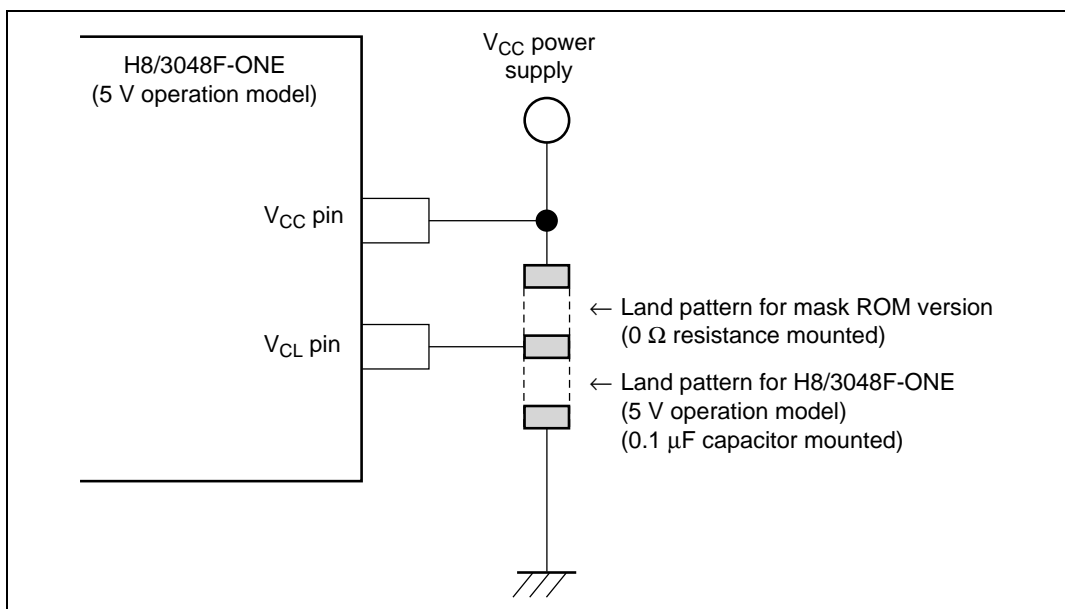

Figure 1.6 Example of Board Pattern Providing for External Capacitor

1.5 Setting Oscillation Settling Wait Time

When software standby mode is used, after exiting software standby mode a wait period must be provided to allow the clock to stabilize. Select the length of time for which the CPU and peripheral functions are to wait by setting bits STS2 to STS0 in the system control register (SYSCR) and bits DIV1 and DIV0 in the division ratio control register (DIVCR) according to the operating frequency of the chip.

For the H8/3048B Group, ensure that the oscillation settling wait time is at least 0.1 ms when operating on an external clock.

For setting details, see section 20.4.3, Selection of Waiting Time for Exit from Software Standby Mode.

1.6 Notes on Crystal Resonator Connection

The H8/3048B Group support an operating frequency of up to 25 MHz. If a crystal resonator with a frequency higher than 20 MHz is connected, attention must be paid to circuit constants such as external load capacitance values. For details see section 19.2.1, Connecting a Crystal Resonator.

Section 2 CPU

2.1 Overview

The H8/300H CPU is a high-speed central processing unit with an internal 32-bit architecture that is upward-compatible with the H8/300 CPU. The H8/300H CPU has sixteen 16-bit general registers, can address a 16-Mbyte linear address space, and is ideal for realtime control.

2.1.1 Features

The H8/300H CPU has the following features.

- Upward compatibility with H8/300 CPU
Can execute H8/300 Series object programs
- General-register architecture
Sixteen 16-bit general registers (also usable as sixteen 8-bit registers or eight 32-bit registers)
- Sixty-two basic instructions
 - 8/16/32-bit data transfer and arithmetic and logic instructions
 - Multiply and divide instructions
 - Powerful bit-manipulation instructions
- Eight addressing modes
 - Register direct [Rn]
 - Register indirect [@ERn]
 - Register indirect with displacement [@(d:16, ERn) or @(d:24, ERn)]
 - Register indirect with post-increment or pre-decrement [@ERn+ or @-ERn]
 - Absolute address [@aa:8, @aa:16, or @aa:24]
 - Immediate [#xx:8, #xx:16, or #xx:32]
 - Program-counter relative [@(d:8, PC) or @(d:16, PC)]
 - Memory indirect [@@aa:8]
- 16-Mbyte linear address space
- High-speed operation
 - All frequently-used instructions execute in two to four states
 - Maximum clock frequency: 25 MHz (H8/3048B Group)
 - 8/16/32-bit register-register add/subtract: 80 ns @ 25 MHz/125 ns @ 16 MHz
 - 8 × 8-bit register-register multiply: 560 ns @ 25 MHz/875 ns @ 16 MHz
 - 16 ÷ 8-bit register-register divide: 560 ns @ 25 MHz/875 ns @ 16 MHz

- 16×16 -bit register-register multiply: 880 ns @ 25 MHz/1,375 ns @ 16 MHz
- $32 \div 16$ -bit register-register divide: 880 ns @ 25 MHz/1,375 ns @ 16 MHz
- Two CPU operating modes
 - Normal mode (not available in the H8/3048B Group)
 - Advanced mode
- Low-power mode
 - Transition to power-down state by SLEEP instruction

2.1.2 Differences from H8/300 CPU

In comparison to the H8/300 CPU, the H8/300H has the following enhancements.

- More general registers
 - Eight 16-bit registers have been added.
- Expanded address space
 - Advanced mode supports a maximum 16-Mbyte address space.
 - Normal mode supports the same 64-kbyte address space as the H8/300 CPU.
(Normal mode is not available in the H8/3048B Group.)
- Enhanced addressing
 - The addressing modes have been enhanced to make effective use of the 16-Mbyte address space.
- Enhanced instructions
 - Data transfer, arithmetic, and logic instructions can operate on 32-bit data.
 - Signed multiply/divide instructions and other instructions have been added.

2.2 CPU Operating Modes

The H8/300H CPU has two operating modes: normal and advanced. Normal mode supports a maximum 64-kbyte address space. Advanced mode supports up to 16 Mbytes. See figure 2.1.

The H8/3048B Group can be used only in advanced mode. (Information from this point on will apply to advanced mode unless otherwise stated.)

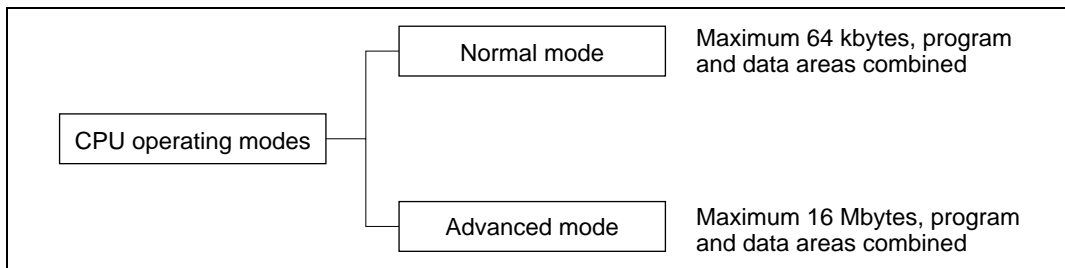

Figure 2.1 CPU Operating Modes

2.3 Address Space

The maximum address space of the H8/300H CPU is 16 Mbytes. The H8/3048B Group has various operating modes (MCU modes), some providing a 1-Mbyte address space, the others supporting the full 16 Mbytes.

Figure 2.2 shows the address ranges of the H8/3048B Group. For further details see section 3.6, Memory Map in Each Operating Mode.

The 1-Mbyte operating modes use 20-bit addressing. The upper 4 bits of effective addresses are ignored.

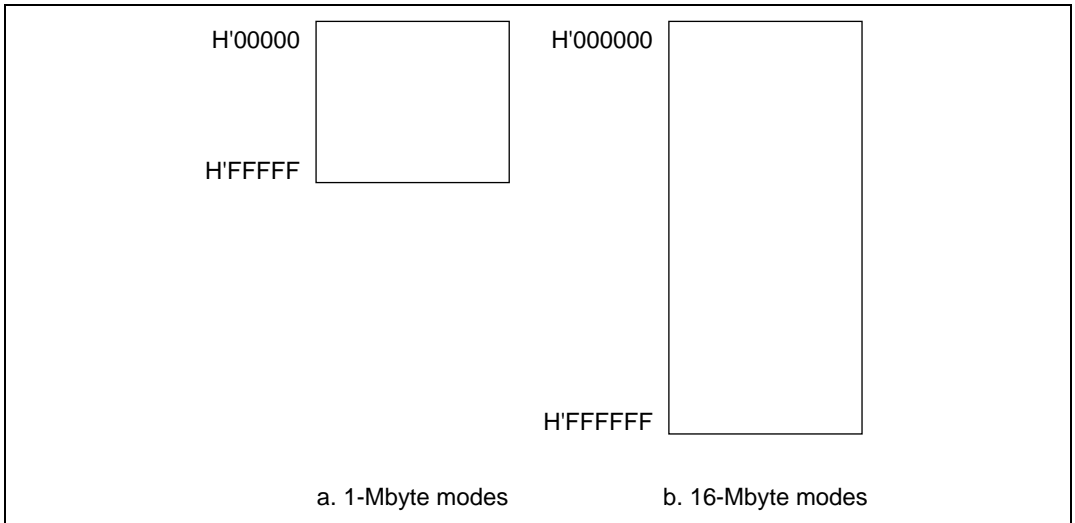

Figure 2.2 Memory Map

2.4 Register Configuration

2.4.1 Overview

The H8/300H CPU has the internal registers shown in figure 2.3. There are two types of registers: general registers and control registers.

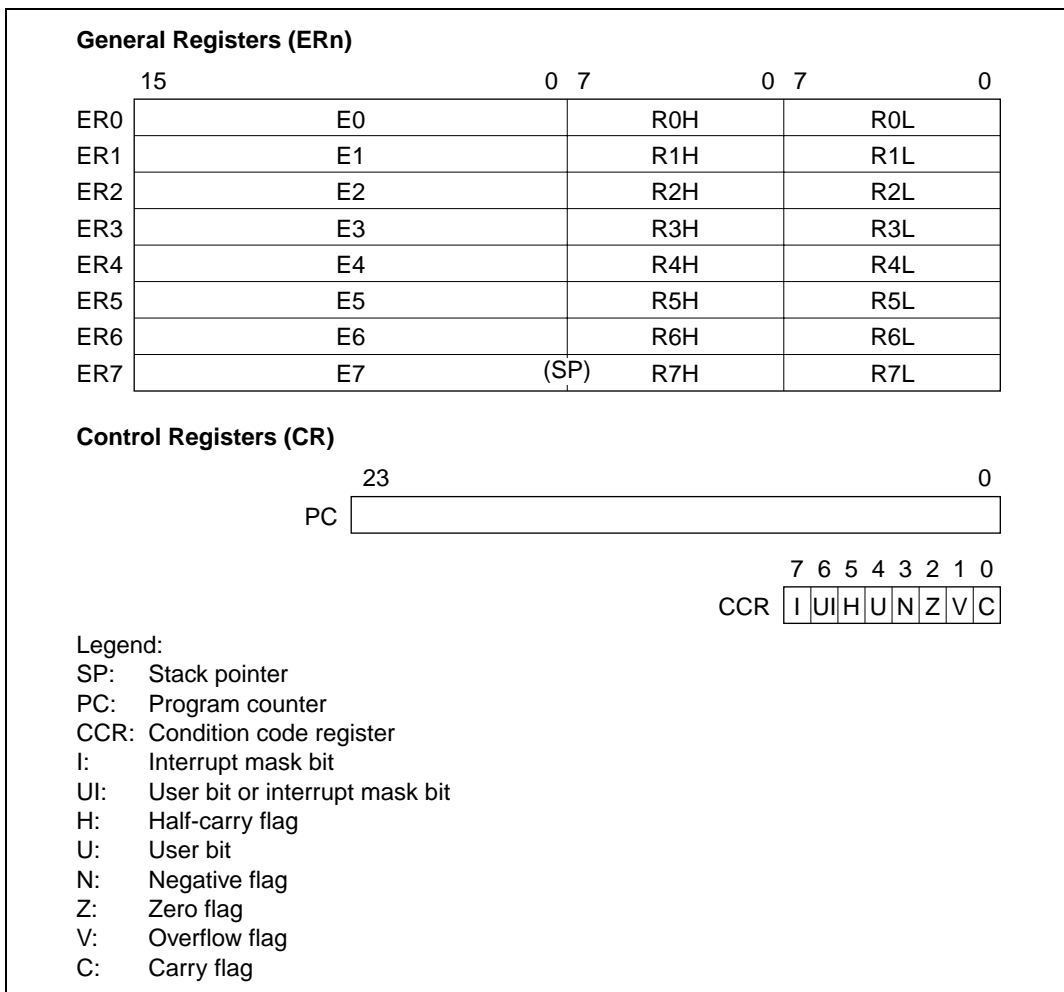

Figure 2.3 CPU Internal Registers

2.4.2 General Registers

The H8/300H CPU has eight 32-bit general registers. These general registers are all functionally alike and can be used without distinction between data registers and address registers. When a general register is used as a data register, it can be accessed as a 32-bit, 16-bit, or 8-bit register. When the general registers are used as 32-bit registers or as address registers, they are designated by the letters ER (ER0 to ER7).

The ER registers divide into 16-bit general registers designated by the letters E (E0 to E7) and R (R0 to R7). These registers are functionally equivalent, providing a maximum sixteen 16-bit registers. The E registers (E0 to E7) are also referred to as extended registers.

The R registers divide into 8-bit general registers designated by the letters RH (R0H to R7H) and RL (R0L to R7L). These registers are functionally equivalent, providing a maximum sixteen 8-bit registers.

Figure 2.4 illustrates the usage of the general registers. The usage of each register can be selected independently.

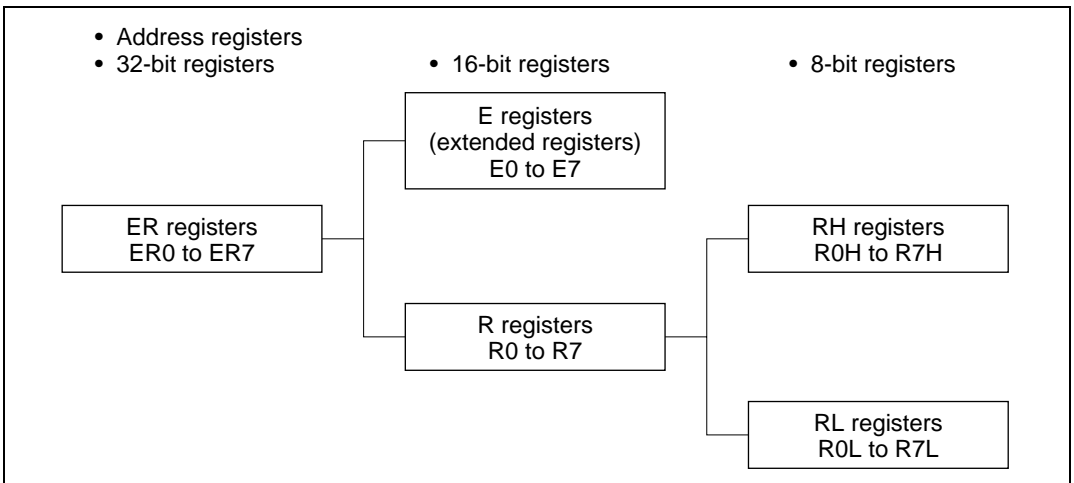

Figure 2.4 Usage of General Registers

General register ER7 has the function of stack pointer (SP) in addition to its general-register function, and is used implicitly in exception handling and subroutine calls. Figure 2.5 shows the stack.

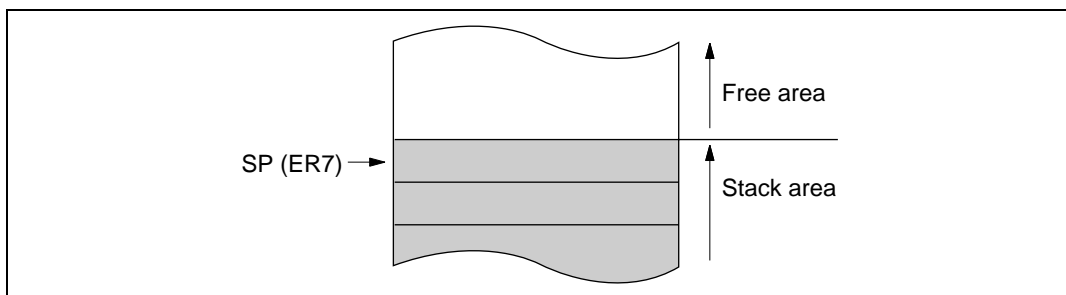

Figure 2.5 Stack

2.4.3 Control Registers

The control registers are the 24-bit program counter (PC) and the 8-bit condition code register (CCR).

Program Counter (PC)

This 24-bit counter indicates the address of the next instruction the CPU will execute. The length of all CPU instructions is 2 bytes (one word) or a multiple of 2 bytes, so the least significant PC bit is ignored. When an instruction is fetched, the least significant PC bit is regarded as 0.

Condition Code Register (CCR)

This 8-bit register contains internal CPU status information, including the interrupt mask bit (I) and half-carry (H), negative (N), zero (Z), overflow (V), and carry (C) flags.

- **Bit 7—Interrupt Mask Bit (I):** Masks interrupts other than NMI when set to 1. NMI is accepted regardless of the I bit setting. The I bit is set to 1 at the start of an exception-handling sequence.
- **Bit 6—User Bit or Interrupt Mask Bit (UI):** Can be written and read by software using the LDC, STC, ANDC, ORC, and XORC instructions. This bit can also be used as an interrupt mask bit. For details see section 5, Interrupt Controller.
- **Bit 5—Half-Carry Flag (H):** When the ADD.B, ADDX.B, SUB.B, SUBX.B, CMP.B, or NEG.B instruction is executed, this flag is set to 1 if there is a carry or borrow at bit 3, and cleared to 0 otherwise. When the ADD.W, SUB.W, CMP.W, or NEG.W instruction is

executed, the H flag is set to 1 if there is a carry or borrow at bit 11, and cleared to 0 otherwise. When the ADD.L, SUB.L, CMP.L, or NEG.L instruction is executed, the H flag is set to 1 if there is a carry or borrow at bit 27, and cleared to 0 otherwise.

- **Bit 4—User Bit (U):** Can be written and read by software using the LDC, STC, ANDC, ORC, and XORC instructions.
- **Bit 3—Negative Flag (N):** Indicates the most significant bit (sign bit) of data.
- **Bit 2—Zero Flag (Z):** Set to 1 to indicate zero data, and cleared to 0 to indicate non-zero data.
- **Bit 1—Overflow Flag (V):** Set to 1 when an arithmetic overflow occurs, and cleared to 0 at other times.
- **Bit 0—Carry Flag (C):** Set to 1 when a carry occurs, and cleared to 0 otherwise. Used by:
 - Add instructions, to indicate a carry
 - Subtract instructions, to indicate a borrow
 - Shift and rotate instructions, to store the value shifted out of the end bitThe carry flag is also used as a bit accumulator by bit manipulation instructions.

Some instructions leave flag bits unchanged. Operations can be performed on CCR by the LDC, STC, ANDC, ORC, and XORC instructions. The N, Z, V, and C flags are used by conditional branch (Bcc) instructions.

For the action of each instruction on the flag bits, see appendix A.1, Instruction List. For the I and UI bits, see section 5, Interrupt Controller.

2.4.4 Initial CPU Register Values

In reset exception handling, PC is initialized to a value loaded from the vector table, and the I bit in CCR is set to 1. The other CCR bits and the general registers are not initialized. In particular, the stack pointer (ER7) is not initialized. The stack pointer must therefore be initialized by an MOV.L instruction executed immediately after a reset.

2.5 Data Formats

The H8/300H CPU can process 1-bit, 4-bit (BCD), 8-bit (byte), 16-bit (word), and 32-bit (longword) data. Bit-manipulation instructions operate on 1-bit data by accessing bit n ($n = 0, 1, 2, \dots, 7$) of byte operand data. The DAA and DAS decimal-adjust instructions treat byte data as two digits of 4-bit BCD data.

2.5.1 General Register Data Formats

Figures 2.6 and 2.7 show the data formats in general registers.

Data Type	General Register	Data Format
1-bit data	RnH	<p>7 0 7 6 5 4 3 2 1 0 Don't care</p>
1-bit data	RnL	<p>7 0 Don't care 7 6 5 4 3 2 1 0</p>
4-bit BCD data	RnH	<p>7 4 3 0 Upper digit Lower digit Don't care</p>
4-bit BCD data	RnL	<p>7 4 3 0 Don't care Upper digit Lower digit</p>
Byte data	RnH	<p>7 0 MSB LSB Don't care</p>
Byte data	RnL	<p>7 0 Don't care MSB LSB</p>

Figure 2.6 General Register Data Formats (1)

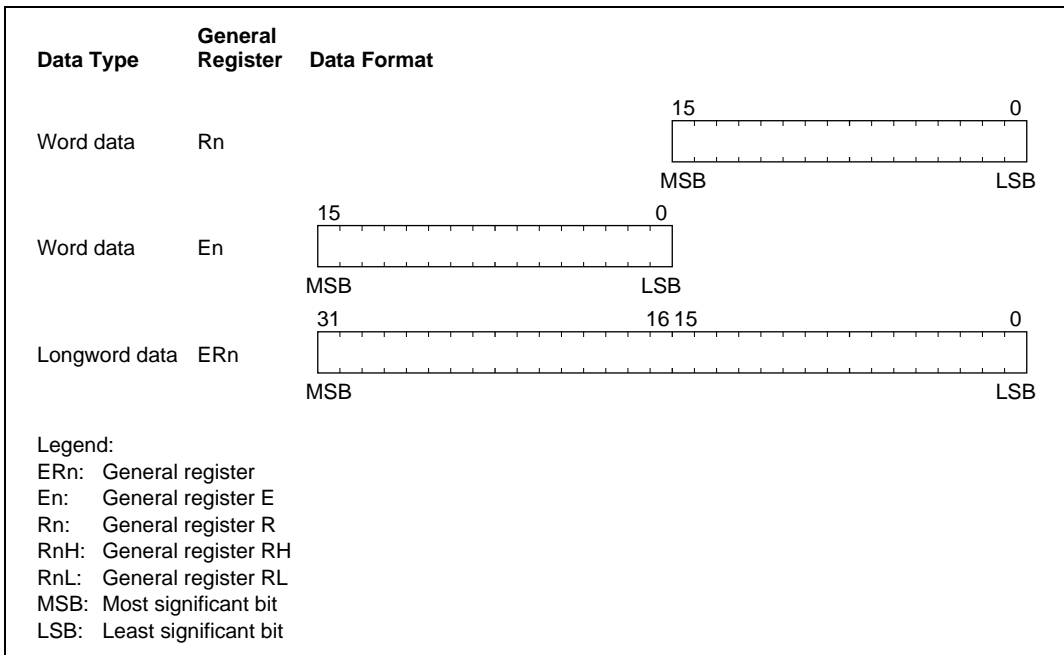

Figure 2.7 General Register Data Formats (2)

2.5.2 Memory Data Formats

Figure 2.8 shows the data formats on memory. The H8/300H CPU can access word data and longword data on memory, but word or longword data must begin at an even address. If an attempt is made to access word or longword data at an odd address, no address error occurs but the least significant bit of the address is regarded as 0, so the access starts at the preceding address. This also applies to instruction fetches.

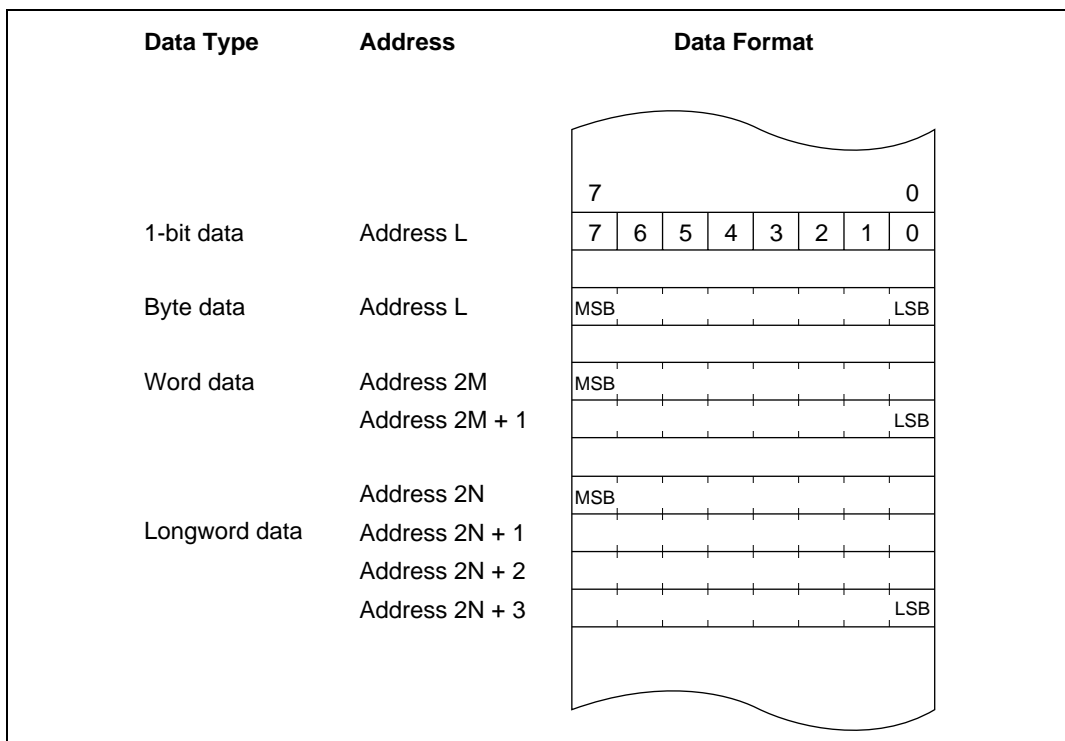

Figure 2.8 Memory Data Formats

When ER7 (SP) is used as an address register to access the stack, the operand size should be word size or longword size.

2.6 Instruction Set

2.6.1 Instruction Set Overview

The H8/300H CPU has 62 types of instructions, which are classified in table 2.1.

Table 2.1 Instruction Classification

Function	Instruction	Types
Data transfer	MOV, PUSH ^{*1} , POP ^{*1} , MOVTPE ^{*2} , MOVFPE ^{*2}	3
Arithmetic operations	ADD, SUB, ADDX, SUBX, INC, DEC, ADDS, SUBS, DAA, DAS, MULXU, MULXS, DIVXU, DIVXS, CMP, NEG, EXTS, EXTU	18
Logic operations	AND, OR, XOR, NOT	4
Shift operations	SHAL, SHAR, SHLL, SHLR, ROTL, ROTR, ROTXL, ROTXR	8
Bit manipulation	BSET, BCLR, BNOT, BTST, BAND, BIAND, BOR, BIOR, BXOR, BIXOR, BLD, BILD, BST, BIST	14
Branch	Bcc ^{*3} , JMP, BSR, JSR, RTS	5
System control	TRAPA, RTE, SLEEP, LDC, STC, ANDC, ORC, XORC, NOP	9
Block data transfer	EPMOV	1

Total 62 types

- Notes: 1. POP.W Rn is identical to MOV.W @SP+, Rn.
 PUSH.W Rn is identical to MOV.W Rn, @-SP.
 POP.L ERn is identical to MOV.L @SP+, Rn.
 PUSH.L ERn is identical to MOV.L Rn, @-SP.
2. Not available in the H8/3048B Group.
3. Bcc is a generic branching instruction.

2.6.2 Instructions and Addressing Modes

Table 2.2 indicates the instructions available in the H8/300H CPU.

Table 2.2 Instructions and Addressing Modes

Function	Instruction	Addressing Modes												
		#xx	Rn	@ERn	@(d:16,ERn)	@(d:24,ERn)	@ERn+/@-ERn	@aa:8	@aa:16	@aa:24	@(d:8,PC)	@(d:16,PC)	@aa:8	
Data transfer	MOV	BWL	BWL	BWL	BWL	BWL	BWL	B	BWL	BWL	—	—	—	—
	POP, PUSH	—	—	—	—	—	—	—	—	—	—	—	—	WL
	MOVFPPE*, MOVTPE*	—	—	—	—	—	—	—	B	—	—	—	—	—
Arithmetic operations	ADD, CMP	BWL	BWL	—	—	—	—	—	—	—	—	—	—	—
	SUB	WL	BWL	—	—	—	—	—	—	—	—	—	—	—
	ADDX, SUBX	B	B	—	—	—	—	—	—	—	—	—	—	—
	ADDS, SUBS	—	L	—	—	—	—	—	—	—	—	—	—	—
	INC, DEC	—	BWL	—	—	—	—	—	—	—	—	—	—	—
	DAA, DAS	—	B	—	—	—	—	—	—	—	—	—	—	—
	MULXU, MULXS, DIVXU, DIVXS	—	BW	—	—	—	—	—	—	—	—	—	—	—
	NEG	—	BWL	—	—	—	—	—	—	—	—	—	—	—
	EXTU, EXTS	—	WL	—	—	—	—	—	—	—	—	—	—	—
Logic operations	AND, OR, XOR	BWL	BWL	—	—	—	—	—	—	—	—	—	—	—
	NOT	—	BWL	—	—	—	—	—	—	—	—	—	—	—
Shift instructions	—	BWL	—	—	—	—	—	—	—	—	—	—	—	
Bit manipulation	—	B	B	—	—	—	—	B	—	—	—	—	—	
Branch	Bcc, BSR	—	—	—	—	—	—	—	—	—	○	○	—	—
	JMP, JSR	—	—	○	—	—	—	—	—	○	—	—	○	—
	RTS	—	—	—	—	—	—	—	—	—	—	—	—	○
System control	TRAPA	—	—	—	—	—	—	—	—	—	—	—	—	○
	RTE	—	—	—	—	—	—	—	—	—	—	—	—	○
	SLEEP	—	—	—	—	—	—	—	—	—	—	—	—	○
	LDC	B	B	W	W	W	W	—	W	W	—	—	—	—
	STC	—	B	W	W	W	W	—	W	W	—	—	—	—
	ANDC, ORC, XORC	B	—	—	—	—	—	—	—	—	—	—	—	—
	NOP	—	—	—	—	—	—	—	—	—	—	—	—	○
Block data transfer	—	—	—	—	—	—	—	—	—	—	—	—	—	BW

Legend:

B: Byte

W: Word

L: Longword

Note: * Not available in the H8/3048B Group.

2.6.3 Tables of Instructions Classified by Function

Tables 2.3 to 2.10 summarize the instructions in each functional category. The operation notation used in these tables is defined next.

Operation Notation

Rd	General register (destination)*
Rs	General register (source)*
Rn	General register*
ERn	General register (32-bit register or address register)
(EAd)	Destination operand
(EAs)	Source operand
CCR	Condition code register
N	N (negative) flag of CCR
Z	Z (zero) flag of CCR
V	V (overflow) flag of CCR
C	C (carry) flag of CCR
PC	Program counter
SP	Stack pointer
#IMM	Immediate data
disp	Displacement
+	Addition
-	Subtraction
×	Multiplication
÷	Division
^	AND logical
∨	OR logical
⊕	Exclusive OR logical
→	Move
¬	NOT (logical complement)
:3/:8/:16/:24	3-, 8-, 16-, or 24-bit length

Note: * General registers include 8-bit registers (R0H to R7H, R0L to R7L), 16-bit registers (R0 to R7, E0 to E7), and 32-bit data or address registers (ER0 to ER7).

Table 2.3 Data Transfer Instructions

Instruction	Size*	Function
MOV	B/W/L	(EAs) → Rd, Rs → (EAd) Moves data between two general registers or between a general register and memory, or moves immediate data to a general register.
MOVFPE	B	(EAs) → Rd Cannot be used in the H8/3048B Group.
MOVTPE	B	Rs → (EAs) Cannot be used in the H8/3048B Group.
POP	W/L	@SP+ → Rn Pops a general register from the stack. POP.W Rn is identical to MOV.W @SP+, Rn. Similarly, POP.L ERn is identical to MOV.L @SP+, ERn.
PUSH	W/L	Rn → @-SP Pushes a general register onto the stack. PUSH.W Rn is identical to MOV.W Rn, @-SP. Similarly, PUSH.L ERn is identical to MOV.L ERn, @-SP.

Note: * Size refers to the operand size.

B: Byte

W: Word

L: Longword

Table 2.4 Arithmetic Operation Instructions

Instruction	Size*	Function
ADD, SUB	B/W/L	$Rd \pm Rs \rightarrow Rd$, $Rd \pm \#IMM \rightarrow Rd$ Performs addition or subtraction on data in two general registers, or on immediate data and data in a general register. (Immediate byte data cannot be subtracted from data in a general register. Use the SUBX or ADD instruction.)
ADDX, SUBX	B	$Rd \pm Rs \pm C \rightarrow Rd$, $Rd \pm \#IMM \pm C \rightarrow Rd$ Performs addition or subtraction with carry or borrow on data in two general registers, or on immediate data and data in a general register.
INC, DEC	B/W/L	$Rd \pm 1 \rightarrow Rd$, $Rd \pm 2 \rightarrow Rd$ Increments or decrements a general register by 1 or 2. (Byte operands can be incremented or decremented by 1 only.)
ADDS, SUBS	L	$Rd \pm 1 \rightarrow Rd$, $Rd \pm 2 \rightarrow Rd$, $Rd \pm 4 \rightarrow Rd$ Adds or subtracts the value 1, 2, or 4 to or from data in a 32-bit register.
DAA, DAS	B	Rd decimal adjust $\rightarrow Rd$ Decimal-adjusts an addition or subtraction result in a general register by referring to CCR to produce 4-bit BCD data.
MULXU	B/W	$Rd \times Rs \rightarrow Rd$ Performs unsigned multiplication on data in two general registers: either 8 bits \times 8 bits \rightarrow 16 bits or 16 bits \times 16 bits \rightarrow 32 bits.
MULXS	B/W	$Rd \times Rs \rightarrow Rd$ Performs signed multiplication on data in two general registers: either 8 bits \times 8 bits \rightarrow 16 bits or 16 bits \times 16 bits \rightarrow 32 bits.
DIVXU	B/W	$Rd \div Rs \rightarrow Rd$ Performs unsigned division on data in two general registers: either 16 bits \div 8 bits \rightarrow 8-bit quotient and 8-bit remainder or 32 bits \div 16 bits \rightarrow 16-bit quotient and 16-bit remainder.
DIVXS	B/W	$Rd \div Rs \rightarrow Rd$ Performs signed division on data in two general registers: either 16 bits \div 8 bits \rightarrow 8-bit quotient and 8-bit remainder, or 32 bits \div 16 bits \rightarrow 16-bit quotient and 16-bit remainder.

Instruction	Size*	Function
CMP	B/W/L	Rd – Rs, Rd – #IMM Compares data in a general register with data in another general register or with immediate data, and sets CCR according to the result.
NEG	B/W/L	0 – Rd → Rd Takes the two's complement (arithmetic complement) of data in a general register.
EXTS	W/L	Rd (sign extension) → Rd Extends byte data in the lower 8 bits of a 16-bit register to word data, or extends word data in the lower 16 bits of a 32-bit register to longword data, by extending the sign bit.
EXTU	W/L	Rd (zero extension) → Rd Extends byte data in the lower 8 bits of a 16-bit register to word data, or extends word data in the lower 16 bits of a 32-bit register to longword data, by padding with zeros.

Note: * Size refers to the operand size.

B: Byte

W: Word

L: Longword

Table 2.5 Logic Operation Instructions

Instruction	Size*	Function
AND	B/W/L	$Rd \wedge Rs \rightarrow Rd, Rd \wedge \#IMM \rightarrow Rd$ Performs a logical AND operation on a general register and another general register or immediate data.
OR	B/W/L	$Rd \vee Rs \rightarrow Rd, Rd \vee \#IMM \rightarrow Rd$ Performs a logical OR operation on a general register and another general register or immediate data.
XOR	B/W/L	$Rd \oplus Rs \rightarrow Rd, Rd \oplus \#IMM \rightarrow Rd$ Performs a logical exclusive OR operation on a general register and another general register or immediate data.
NOT	B/W/L	$\neg Rd \rightarrow Rd$ Takes the one's complement of general register contents.

Note: * Size refers to the operand size.

B: Byte
W: Word
L: Longword

Table 2.6 Shift Instructions

Instruction	Size*	Function
SHAL, SHAR	B/W/L	$Rd \text{ (shift)} \rightarrow Rd$ Performs an arithmetic shift on general register contents.
SHLL, SHLR	B/W/L	$Rd \text{ (shift)} \rightarrow Rd$ Performs a logical shift on general register contents.
ROTL, ROTR	B/W/L	$Rd \text{ (rotate)} \rightarrow Rd$ Rotates general register contents.
ROTXL, ROTXR	B/W/L	$Rd \text{ (rotate)} \rightarrow Rd$ Rotates general register contents through the carry bit.

Note: * Size refers to the operand size.

B: Byte
W: Word
L: Longword

Table 2.7 Bit Manipulation Instructions

Instruction	Size*	Function
BSET	B	$1 \rightarrow (\text{<bit-No.> of <EAd>})$ Sets a specified bit in a general register or memory operand to 1. The bit number is specified by 3-bit immediate data or the lower 3 bits of a general register.
BCLR	B	$0 \rightarrow (\text{<bit-No.> of <EAd>})$ Clears a specified bit in a general register or memory operand to 0. The bit number is specified by 3-bit immediate data or the lower 3 bits of a general register.
BNOT	B	$\neg (\text{<bit-No.> of <EAd>}) \rightarrow (\text{<bit-No.> of <EAd>})$ Inverts a specified bit in a general register or memory operand. The bit number is specified by 3-bit immediate data or the lower 3 bits of a general register.
BTST	B	$\neg (\text{<bit-No.> of <EAd>}) \rightarrow Z$ Tests a specified bit in a general register or memory operand and sets or clears the Z flag accordingly. The bit number is specified by 3-bit immediate data or the lower 3 bits of a general register.
BAND	B	$C \wedge (\text{<bit-No.> of <EAd>}) \rightarrow C$ ANDs the carry flag with a specified bit in a general register or memory operand and stores the result in the carry flag.
BIAND	B	$C \wedge [\neg (\text{<bit-No.> of <EAd>})] \rightarrow C$ ANDs the carry flag with the inverse of a specified bit in a general register or memory operand and stores the result in the carry flag. The bit number is specified by 3-bit immediate data.
BOR	B	$C \vee (\text{<bit-No.> of <EAd>}) \rightarrow C$ ORs the carry flag with a specified bit in a general register or memory operand and stores the result in the carry flag.
BIOR	B	$C \vee [\neg (\text{<bit-No.> of <EAd>})] \rightarrow C$ ORs the carry flag with the inverse of a specified bit in a general register or memory operand and stores the result in the carry flag. The bit number is specified by 3-bit immediate data.

Instruction	Size*	Function
BXOR	B	$C \oplus (\text{<bit-No.> of <EAd>}) \rightarrow C$ Exclusive-ORs the carry flag with a specified bit in a general register or memory operand and stores the result in the carry flag.
BIXOR	B	$C \oplus [\neg (\text{<bit-No.> of <EAd>})] \rightarrow C$ Exclusive-ORs the carry flag with the inverse of a specified bit in a general register or memory operand and stores the result in the carry flag. The bit number is specified by 3-bit immediate data.
BLD	B	$(\text{<bit-No.> of <EAd>}) \rightarrow C$ Transfers a specified bit in a general register or memory operand to the carry flag.
BILD	B	$\neg (\text{<bit-No.> of <EAd>}) \rightarrow C$ Transfers the inverse of a specified bit in a general register or memory operand to the carry flag. The bit number is specified by 3-bit immediate data.
BST	B	$C \rightarrow (\text{<bit-No.> of <EAd>})$ Transfers the carry flag value to a specified bit in a general register or memory operand.
BIST	B	$C \rightarrow \neg (\text{<bit-No.> of <EAd>})$ Transfers the inverse of the carry flag value to a specified bit in a general register or memory operand. The bit number is specified by 3-bit immediate data.

Note: * Size refers to the operand size.

B: Byte

Table 2.8 Branching Instructions

Instruction	Size	Function																																																			
Bcc	—	Branches to a specified address if a specified condition is true. The branching conditions are listed below.																																																			
		<table border="1"> <thead> <tr> <th>Mnemonic</th> <th>Description</th> <th>Condition</th> </tr> </thead> <tbody> <tr> <td>BRA (BT)</td> <td>Always (true)</td> <td>Always</td> </tr> <tr> <td>BRN (BF)</td> <td>Never (false)</td> <td>Never</td> </tr> <tr> <td>BHI</td> <td>High</td> <td>$C \vee Z = 0$</td> </tr> <tr> <td>BLS</td> <td>Low or same</td> <td>$C \vee Z = 1$</td> </tr> <tr> <td>Bcc (BHS)</td> <td>Carry clear (high or same)</td> <td>$C = 0$</td> </tr> <tr> <td>BCS (BLO)</td> <td>Carry set (low)</td> <td>$C = 1$</td> </tr> <tr> <td>BNE</td> <td>Not equal</td> <td>$Z = 0$</td> </tr> <tr> <td>BEQ</td> <td>Equal</td> <td>$Z = 1$</td> </tr> <tr> <td>BVC</td> <td>Overflow clear</td> <td>$V = 0$</td> </tr> <tr> <td>BVS</td> <td>Overflow set</td> <td>$V = 1$</td> </tr> <tr> <td>BPL</td> <td>Plus</td> <td>$N = 0$</td> </tr> <tr> <td>BMI</td> <td>Minus</td> <td>$N = 1$</td> </tr> <tr> <td>BGE</td> <td>Greater or equal</td> <td>$N \oplus V = 0$</td> </tr> <tr> <td>BLT</td> <td>Less than</td> <td>$N \oplus V = 1$</td> </tr> <tr> <td>BGT</td> <td>Greater than</td> <td>$Z \vee (N \oplus V) = 0$</td> </tr> <tr> <td>BLE</td> <td>Less or equal</td> <td>$Z \vee (N \oplus V) = 1$</td> </tr> </tbody> </table>	Mnemonic	Description	Condition	BRA (BT)	Always (true)	Always	BRN (BF)	Never (false)	Never	BHI	High	$C \vee Z = 0$	BLS	Low or same	$C \vee Z = 1$	Bcc (BHS)	Carry clear (high or same)	$C = 0$	BCS (BLO)	Carry set (low)	$C = 1$	BNE	Not equal	$Z = 0$	BEQ	Equal	$Z = 1$	BVC	Overflow clear	$V = 0$	BVS	Overflow set	$V = 1$	BPL	Plus	$N = 0$	BMI	Minus	$N = 1$	BGE	Greater or equal	$N \oplus V = 0$	BLT	Less than	$N \oplus V = 1$	BGT	Greater than	$Z \vee (N \oplus V) = 0$	BLE	Less or equal	$Z \vee (N \oplus V) = 1$
Mnemonic	Description	Condition																																																			
BRA (BT)	Always (true)	Always																																																			
BRN (BF)	Never (false)	Never																																																			
BHI	High	$C \vee Z = 0$																																																			
BLS	Low or same	$C \vee Z = 1$																																																			
Bcc (BHS)	Carry clear (high or same)	$C = 0$																																																			
BCS (BLO)	Carry set (low)	$C = 1$																																																			
BNE	Not equal	$Z = 0$																																																			
BEQ	Equal	$Z = 1$																																																			
BVC	Overflow clear	$V = 0$																																																			
BVS	Overflow set	$V = 1$																																																			
BPL	Plus	$N = 0$																																																			
BMI	Minus	$N = 1$																																																			
BGE	Greater or equal	$N \oplus V = 0$																																																			
BLT	Less than	$N \oplus V = 1$																																																			
BGT	Greater than	$Z \vee (N \oplus V) = 0$																																																			
BLE	Less or equal	$Z \vee (N \oplus V) = 1$																																																			
JMP	—	Branches unconditionally to a specified address																																																			
BSR	—	Branches to a subroutine at a specified address																																																			
JSR	—	Branches to a subroutine at a specified address																																																			
RTS	—	Returns from a subroutine																																																			

Table 2.9 System Control Instructions

Instruction	Size*	Function
TRAPA	—	Starts trap-instruction exception handling
RTE	—	Returns from an exception-handling routine
SLEEP	—	Causes a transition to the power-down state
LDC	B/W	(EAs) → CCR Moves the source operand contents to the condition code register. The condition code register size is one byte, but in transfer from memory, data is read by word access.
STC	B/W	CCR → (EAd) Transfers the CCR contents to a destination location. The condition code register size is one byte, but in transfer to memory, data is written by word access.
ANDC	B	CCR ∧ #IMM → CCR Logically ANDs the condition code register with immediate data.
ORC	B	CCR ∨ #IMM → CCR Logically ORs the condition code register with immediate data.
XORC	B	CCR ⊕ #IMM → CCR Logically exclusive-ORs the condition code register with immediate data.
NOP	—	PC + 2 → PC Only increments the program counter.

Note: * Size refers to the operand size.

B: Byte

W: Word

Table 2.10 Block Transfer Instruction

Instruction	Size	Function
EEPMOV.B	—	<p>if R4L ≠ 0 then</p> <p style="padding-left: 40px;">repeat @ER5+ → @ER6+, R4L – 1 → R4L</p> <p style="padding-left: 40px;">until R4L = 0</p> <p>else next;</p>
EEPMOV.W	—	<p>if R4 ≠ 0 then</p> <p style="padding-left: 40px;">repeat @ER5+ → @ER6+, R4 – 1 → R4</p> <p style="padding-left: 40px;">until R4 = 0</p> <p>else next;</p> <p>Transfers a data block according to parameters set in general registers R4L or R4, ER5, and ER6.</p> <p>R4L or R4: Size of block (bytes)</p> <p>ER5: Starting source address</p> <p>ER6: Starting destination address</p> <p>Execution of the next instruction begins as soon as the transfer is completed.</p>

2.6.4 Basic Instruction Formats

The H8/300H instructions consist of 2-byte (1-word) units. An instruction consists of an operation field (OP field), a register field (r field), an effective address extension (EA field), and a condition field (cc).

Operation Field: Indicates the function of the instruction, the addressing mode, and the operation to be carried out on the operand. The operation field always includes the first 4 bits of the instruction. Some instructions have two operation fields.

Register Field: Specifies a general register. Address registers are specified by 3 bits, data registers by 3 bits or 4 bits. Some instructions have two register fields. Some have no register field.

Effective Address Extension: Eight, 16, or 32 bits specifying immediate data, an absolute address, or a displacement. A 24-bit address or displacement is treated as 32-bit data in which the first 8 bits are 0 (H'00).

Condition Field: Specifies the branching condition of Bcc instructions.

Figure 2.9 shows examples of instruction formats.

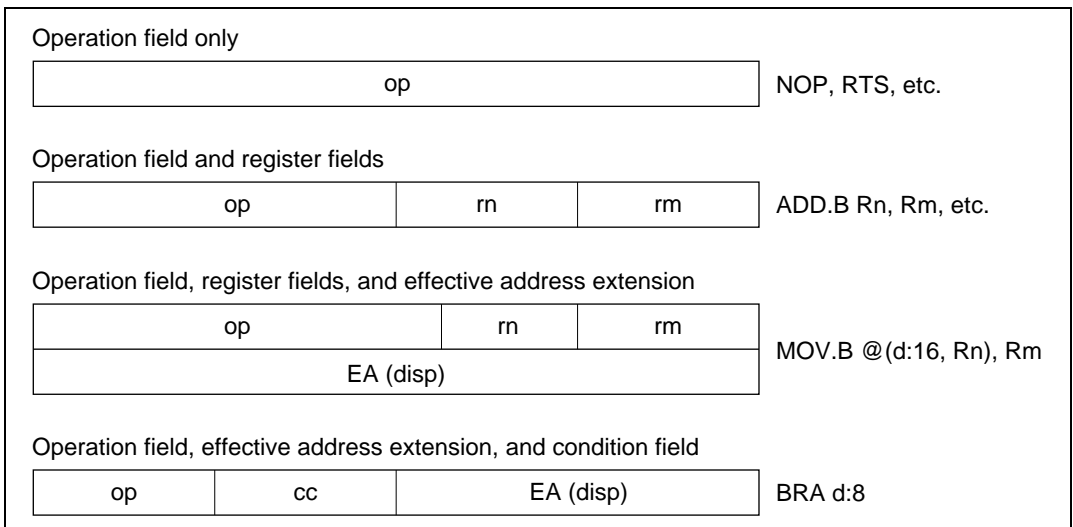

Figure 2.9 Instruction Formats

2.6.5 Notes on Use of Bit Manipulation Instructions

The BSET, BCLR, BNOT, BST, and BIST instructions read a byte of data, modify a bit in the byte, then write the byte back. Care is required when these instructions are used to access registers with write-only bits, or to access ports.

The BCLR instruction can be used to clear flags in the internal I/O registers. In an interrupt-handling routine, for example, if it is known that the flag is set to 1, it is not necessary to read the flag ahead of time.

Step		Description
1	Read	Read data (byte unit) at the specified address
2	Bit manipulation	Modify the specified bit in the read data
3	Write	Write the modified data (byte unit) to the specified address

In the following example, a BCLR instruction is executed on the data direction register (DDR) of port 4.

P4₇ and P4₆ are set as input pins, and are inputting low-level and high-level signals, respectively.

P4₅ to P4₀ are set as output pins, and are in the low-level output state.

In this example, the BCLR instruction is used to make P4₀ an input port.

Before Execution of BCLR Instruction

	P4 ₇	P4 ₆	P4 ₅	P4 ₄	P4 ₃	P4 ₂	P4 ₁	P4 ₀
Input/output	Input	Input	Output	Output	Output	Output	Output	Output
DDR	0	0	1	1	1	1	1	1
DR	1	0	0	0	0	0	0	0

Execution of BCLR Instruction

```
BCLR #0, @P4DDR ; Execute BCLR instruction on DDR
```

After Execution of BCLR Instruction

	P4 ₇	P4 ₆	P4 ₅	P4 ₄	P4 ₃	P4 ₂	P4 ₁	P4 ₀
Input/output	Output	Output	Output	Output	Output	Output	Output	Input
DDR	1	1	1	1	1	1	1	0
DR	1	0	0	0	0	0	0	0

Explanation of BCLR Instruction

To execute the BCLR instruction, the CPU begins by reading P4DDR. Since P4DDR is a write-only register, it is read as H'FF, even though its true value is H'3F.

Next the CPU clears bit 0 of the read data, changing the value to H'FE.

Finally, the CPU writes this value (H'FE) back to DDR to complete the BCLR instruction.

As a result, P4₀DDR is cleared to 0, making P4₀ an input pin. In addition, P4₇DDR and P4₆DDR are set to 1, making P4₇ and P4₆ output pins.

The BCLR instruction can be used to clear flags in the internal I/O registers to 0. In an interrupt-handling routine, for example, if it is known that the flag is set to 1, it is not necessary to read the flag ahead of time.

2.7 Addressing Modes and Effective Address Calculation

2.7.1 Addressing Modes

The H8/300H CPU supports the eight addressing modes listed in table 2.11. Each instruction uses a subset of these addressing modes. Arithmetic and logic instructions can use the register direct and immediate modes. Data transfer instructions can use all addressing modes except program-counter relative and memory indirect. Bit manipulation instructions use register direct, register indirect, or absolute (@aa:8) addressing mode to specify an operand, and register direct (BSET, BCLR, BNOT, and BTST instructions) or immediate (3-bit) addressing mode to specify a bit number in the operand.

Table 2.11 Addressing Modes

No.	Addressing Mode	Symbol
1	Register direct	Rn
2	Register indirect	@ERn
3	Register indirect with displacement	@(d:16, ERn)/@(d:24, ERn)
4	Register indirect with post-increment	@ERn+
	Register indirect with pre-decrement	@-ERn
5	Absolute address	@aa:8/@aa:16/@aa:24
6	Immediate	#xx:8/#xx:16/#xx:32
7	Program-counter relative	@(d:8, PC)/@(d:16, PC)
8	Memory indirect	@@aa:8

1. Register Direct—Rn

The register field of the instruction code specifies an 8-, 16-, or 32-bit register containing the operand. R0H to R7H and R0L to R7L can be specified as 8-bit registers. R0 to R7 and E0 to E7 can be specified as 16-bit registers. ER0 to ER7 can be specified as 32-bit registers.

2. Register Indirect—@ERn

The register field of the instruction code specifies an address register (ERn), the lower 24 bits of which contain the address of the operand.

3. Register Indirect with Displacement—@(d:16, ERn) or @(d:24, ERn)

A 16-bit or 24-bit displacement contained in the instruction code is added to the contents of an address register (ERn) specified by the register field of the instruction, and the lower 24 bits of the sum specify the address of a memory operand. A 16-bit displacement is sign-extended when added.

4. Register Indirect with Post-Increment or Pre-Decrement—@ERn+ or @-ERn

- Register indirect with post-increment—@ERn+

The register field of the instruction code specifies an address register (ERn) the lower 24 bits of which contain the address of a memory operand. After the operand is accessed, 1, 2, or 4 is added to the address register contents (32 bits) and the sum is stored in the address register. The value added is 1 for byte access, 2 for word access, or 4 for longword access. For word or longword access, the register value should be even.

- Register indirect with pre-decrement—@-ERn

The value 1, 2, or 4 is subtracted from an address register (ERn) specified by the register field in the instruction code, and the lower 24 bits of the result become the address of a memory operand. The result is also stored in the address register. The value subtracted is 1 for byte access, 2 for word access, or 4 for longword access. For word or longword access, the resulting register value should be even.

5. Absolute Address—@aa:8, @aa:16, or @aa:24

The instruction code contains the absolute address of a memory operand. The absolute address may be 8 bits long (@aa:8), 16 bits long (@aa:16), or 24 bits long (@aa:24). For an 8-bit absolute address, the upper 16 bits are all assumed to be 1 (H'FFFF). For a 16-bit absolute address the upper 8 bits are a sign extension. A 24-bit absolute address can access the entire address space. Table 2.12 indicates the accessible address ranges.

Table 2.12 Absolute Address Access Ranges

Absolute Address	1-Mbyte Modes	16-Mbyte Modes
8 bits (@aa:8)	H'FFF00 to H'FFFFF (1048320 to 1048575)	H'FFFF00 to H'FFFFFFF (16776960 to 16777215)
16 bits (@aa:16)	H'00000 to H'07FFF, H'F8000 to H'FFFFFF (0 to 32767, 1015808 to 1048575)	H'000000 to H'007FFF, H'FF8000 to H'FFFFFFF (0 to 32767, 16744448 to 16777215)
24 bits (@aa:24)	H'00000 to H'FFFFFF (0 to 1048575)	H'000000 to H'FFFFFFF (0 to 16777215)

6. Immediate—#xx:8, #xx:16, or #xx:32

The instruction code contains 8-bit (#xx:8), 16-bit (#xx:16), or 32-bit (#xx:32) immediate data as an operand.

The instruction codes of the ADDS, SUBS, INC, and DEC instructions contain immediate data implicitly. The instruction codes of some bit manipulation instructions contain 3-bit immediate data specifying a bit number. The TRAPA instruction code contains 2-bit immediate data specifying a vector address.

7. Program-Counter Relative—@(d:8, PC) or @(d:16, PC)

This mode is used in the Bcc and BSR instructions. An 8-bit or 16-bit displacement contained in the instruction code is sign-extended to 24 bits and added to the 24-bit PC contents to generate a 24-bit branch address. The PC value to which the displacement is added is the address of the first byte of the next instruction, so the possible branching range is -126 to $+128$ bytes (-63 to $+64$ words) or -32766 to $+32768$ bytes (-16383 to $+16384$ words) from the branch instruction. The resulting value should be an even number.

8. Memory Indirect—@@aa:8

This mode can be used by the JMP and JSR instructions. The instruction code contains an 8-bit absolute address specifying a memory operand. This memory operand contains a branch address. The memory operand is accessed by longword access. The first byte of the memory operand is ignored, generating a 24-bit branch address. See figure 2.10. The upper bits of the 8-bit absolute address are assumed to be 0 (H'0000), so the address range is 0 to 255 (H'000000 to H'0000FF). Note that the first part of this range is also the exception vector area. For further details see section 5, Interrupt Controller.

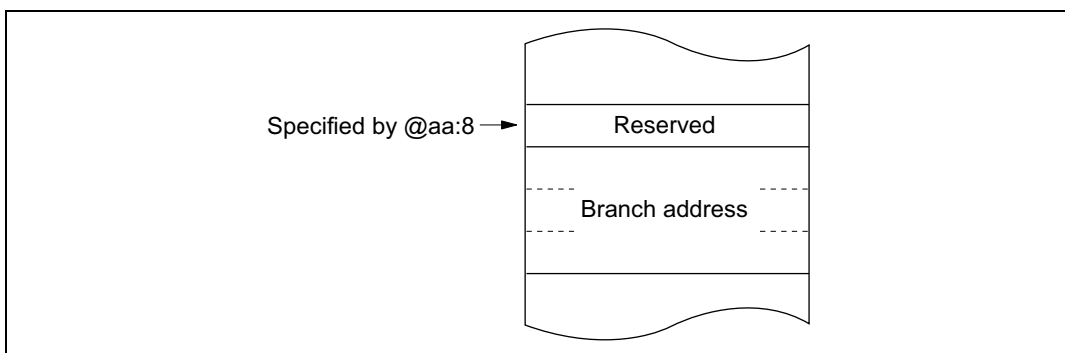

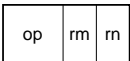
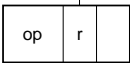
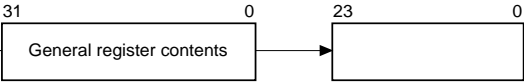

Figure 2.10 Memory-Indirect Branch Address Specification

When a word-size or longword-size memory operand is specified, or when a branch address is specified, if the specified memory address is odd, the least significant bit is regarded as 0. The accessed data or instruction code therefore begins at the preceding address. See section 2.5.2, Memory Data Formats.

2.7.2 Effective Address Calculation

Table 2.13 explains how an effective address is calculated in each addressing mode. In the 1-Mbyte operating modes the upper 4 bits of the calculated address are ignored in order to generate a 20-bit effective address.

Table 2.13 Effective Address Calculation

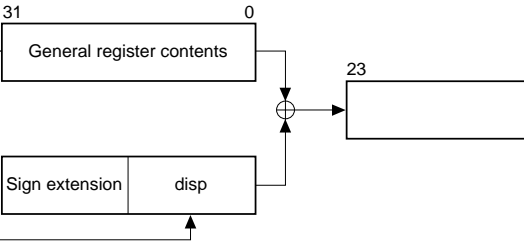
No.	Addressing Mode and Instruction Format	Effective Address Calculation	Effective Address
1	Register direct (Rn) 		Operand is general register contents
2	Register indirect (@ERn)		
3	Register indirect with displacement @(d:16, ERn)/@(d:24, ERn)		
4.	Register indirect with post-increment or pre-decrement	<ul style="list-style-type: none"> Register indirect with post-increment @ERn+  <ul style="list-style-type: none"> Register indirect with pre-decrement @-ERn 	

1 for a byte operand, 2 for a word operand, 4 for a longword operand

No.	Addressing Mode and Instruction Format	Effective Address Calculation	Effective Address																
5	Absolute address																		
	@aa:8																		
	<table border="1"> <tr> <td>op</td> <td>abs</td> </tr> </table>	op	abs		<table border="1"> <tr> <td>23</td> <td>8</td> <td>7</td> <td>0</td> </tr> <tr> <td colspan="2">H'FFFF</td> <td colspan="2"></td> </tr> </table>	23	8	7	0	H'FFFF									
op	abs																		
23	8	7	0																
H'FFFF																			
	@aa:16																		
	<table border="1"> <tr> <td>op</td> <td>abs</td> </tr> </table>	op	abs		<table border="1"> <tr> <td>23</td> <td>16</td> <td>15</td> <td>0</td> </tr> <tr> <td colspan="2">Sign extension</td> <td colspan="2"></td> </tr> </table>	23	16	15	0	Sign extension									
op	abs																		
23	16	15	0																
Sign extension																			
	@aa:24																		
	<table border="1"> <tr> <td>op</td> <td rowspan="2">abs</td> </tr> <tr> <td colspan="2"></td> </tr> </table>	op	abs				<table border="1"> <tr> <td>23</td> <td>0</td> </tr> <tr> <td colspan="2"></td> </tr> </table>	23	0										
op	abs																		
23	0																		
6	Immediate #xx:8, #xx:16, or #xx:32		Operand is immediate data																
	<table border="1"> <tr> <td>op</td> <td>IMM</td> </tr> </table>	op	IMM																
op	IMM																		
7	Program-counter relative @(d:8, PC) or @(d:16, PC)																		
	<table border="1"> <tr> <td>op</td> <td>disp</td> </tr> </table>	op	disp	<table border="1"> <tr> <td>23</td> <td>0</td> </tr> <tr> <td colspan="2">PC contents</td> </tr> </table> <table border="1"> <tr> <td>Sign extension</td> <td>disp</td> </tr> </table> <table border="1"> <tr> <td>23</td> <td>0</td> </tr> <tr> <td colspan="2"></td> </tr> </table>	23	0	PC contents		Sign extension	disp	23	0			<table border="1"> <tr> <td>23</td> <td>0</td> </tr> <tr> <td colspan="2"></td> </tr> </table>	23	0		
op	disp																		
23	0																		
PC contents																			
Sign extension	disp																		
23	0																		
23	0																		

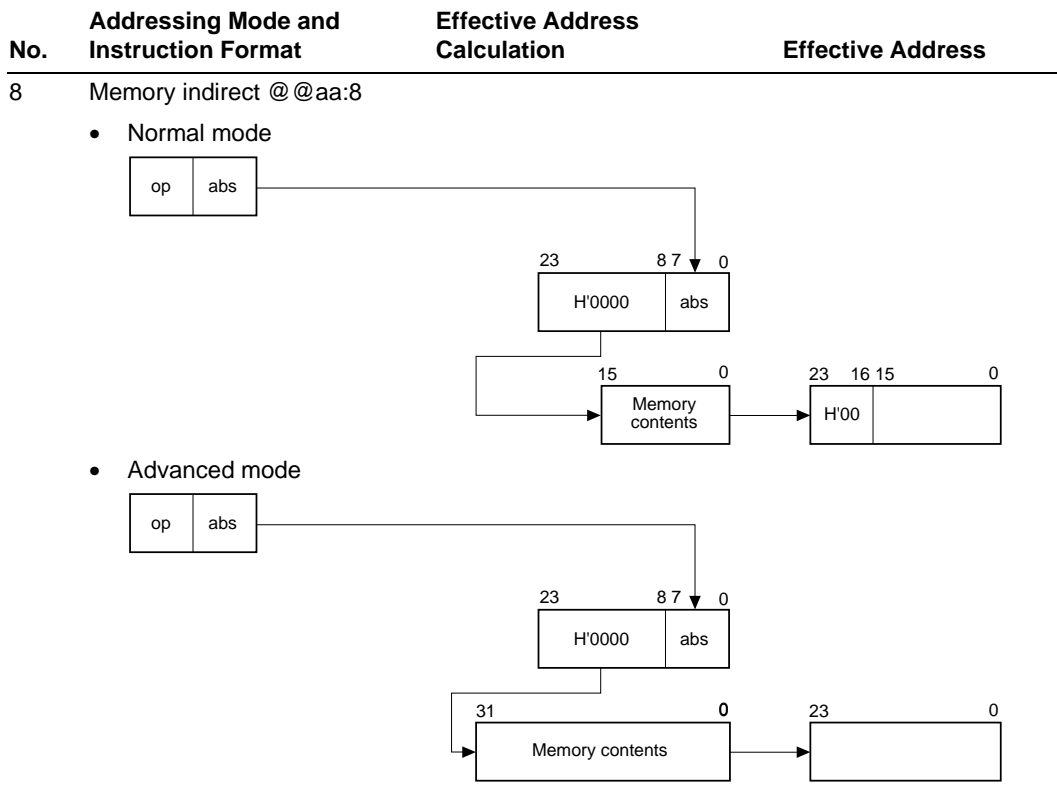

Legend:

r, rm, rn: Register field

op: Operation field

disp: Displacement

IMM: Immediate data

abs: Absolute address

2.8 Processing States

2.8.1 Overview

The H8/300H CPU has five processing states: the program execution state, exception-handling state, power-down state, reset state, and bus-released state. The power-down state includes sleep mode, software standby mode, and hardware standby mode. Figure 2.11 classifies the processing states. Figure 2.13 indicates the state transitions.

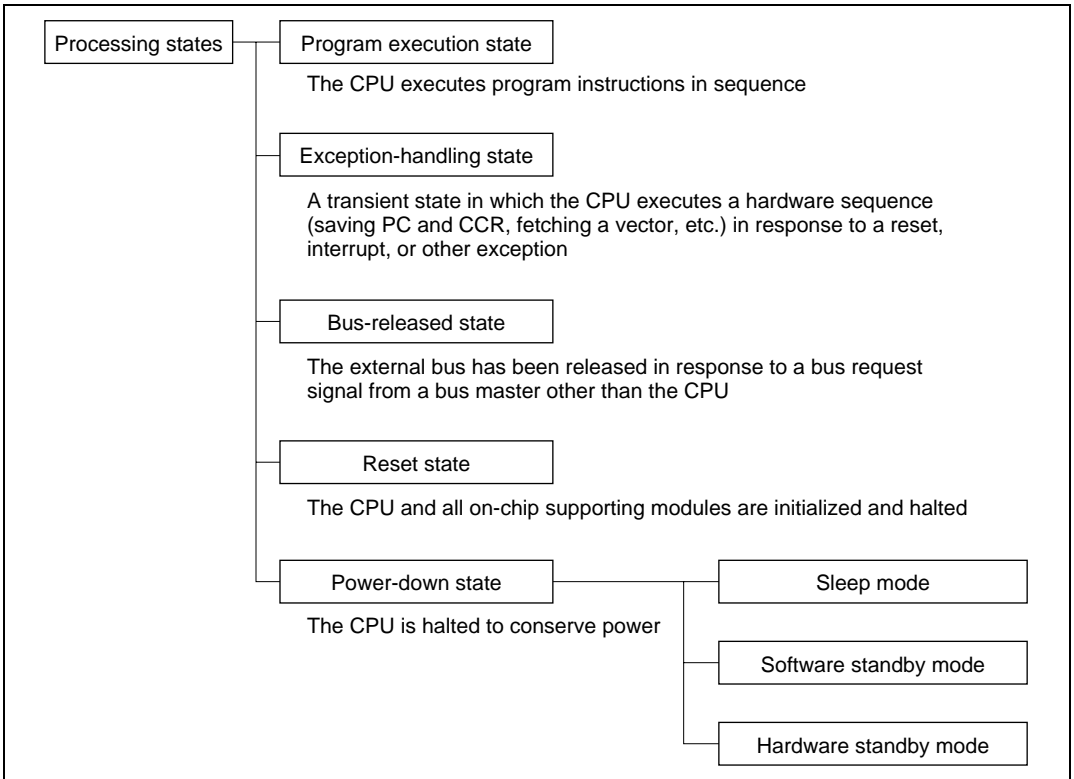

Figure 2.11 Processing States

2.8.2 Program Execution State

In this state the CPU executes program instructions in normal sequence.

2.8.3 Exception-Handling State

The exception-handling state is a transient state that occurs when the CPU alters the normal program flow due to a reset, interrupt, or trap instruction. The CPU fetches a starting address from the exception vector table and branches to that address. In interrupt and trap exception handling the CPU references the stack pointer (ER7) and saves the program counter and condition code register.

Types of Exception Handling and Their Priority: Exception handling is performed for resets, interrupts, and trap instructions. Table 2.14 indicates the types of exception handling and their priority. Trap instruction exceptions are accepted at all times in the program execution state.

Table 2.14 Exception Handling Types and Priority

Priority	Type of Exception	Detection Timing	Start of Exception Handling
High ↑ Low	Reset	Synchronized with clock	Exception handling starts immediately when $\overline{\text{RES}}$ changes from low to high
	Interrupt	End of instruction execution or end of exception handling*	When an interrupt is requested, exception handling starts at the end of the current instruction or current exception-handling sequence
	Trap instruction	When TRAPA instruction is executed	Exception handling starts when a trap (TRAPA) instruction is executed

Note: * Interrupts are not detected at the end of the ANDC, ORC, XORC, and LDC instructions, or immediately after reset exception handling.

Figure 2.12 classifies the exception sources. For further details about exception sources, vector numbers, and vector addresses, see section 4, Exception Handling, and section 5, Interrupt Controller.

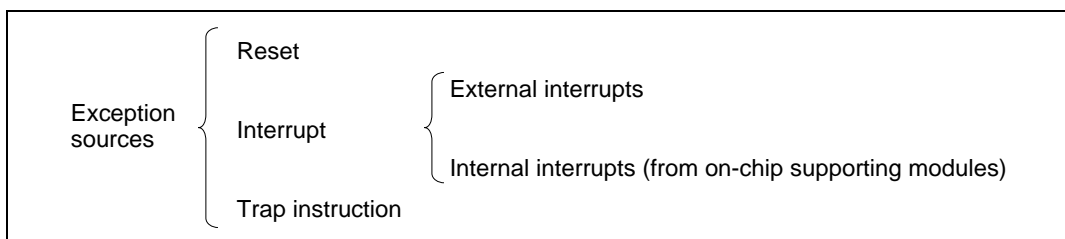

Figure 2.12 Classification of Exception Sources

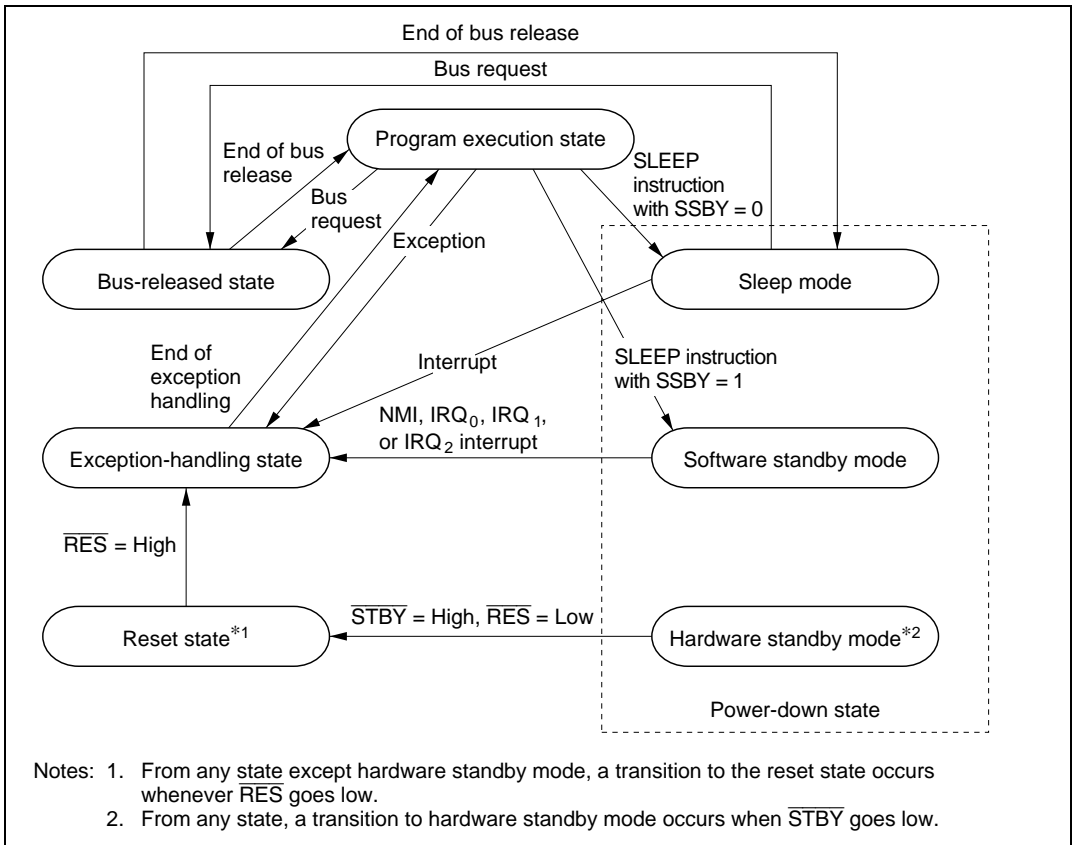

Figure 2.13 State Transitions

2.8.4 Exception-Handling Sequences

Reset Exception Handling: Reset exception handling has the highest priority. The reset state is entered when the \overline{RES} signal goes low. Reset exception handling starts after that, when \overline{RES} changes from low to high. When reset exception handling starts the CPU fetches a start address from the exception vector table and starts program execution from that address. All interrupts, including NMI, are disabled during the reset exception-handling sequence and immediately after it ends.

Interrupt Exception Handling and Trap Instruction Exception Handling: When these exception-handling sequences begin, the CPU references the stack pointer (ER7) and pushes the program counter and condition code register on the stack. Next, if the UE bit in the system control register (SYSCR) is set to 1, the CPU sets the I bit in the condition code register to 1. If the UE bit

is cleared to 0, the CPU sets both the I bit and the UI bit in the condition code register to 1. Then the CPU fetches a start address from the exception vector table and execution branches to that address.

Figure 2.14 shows the stack after the exception-handling sequence.

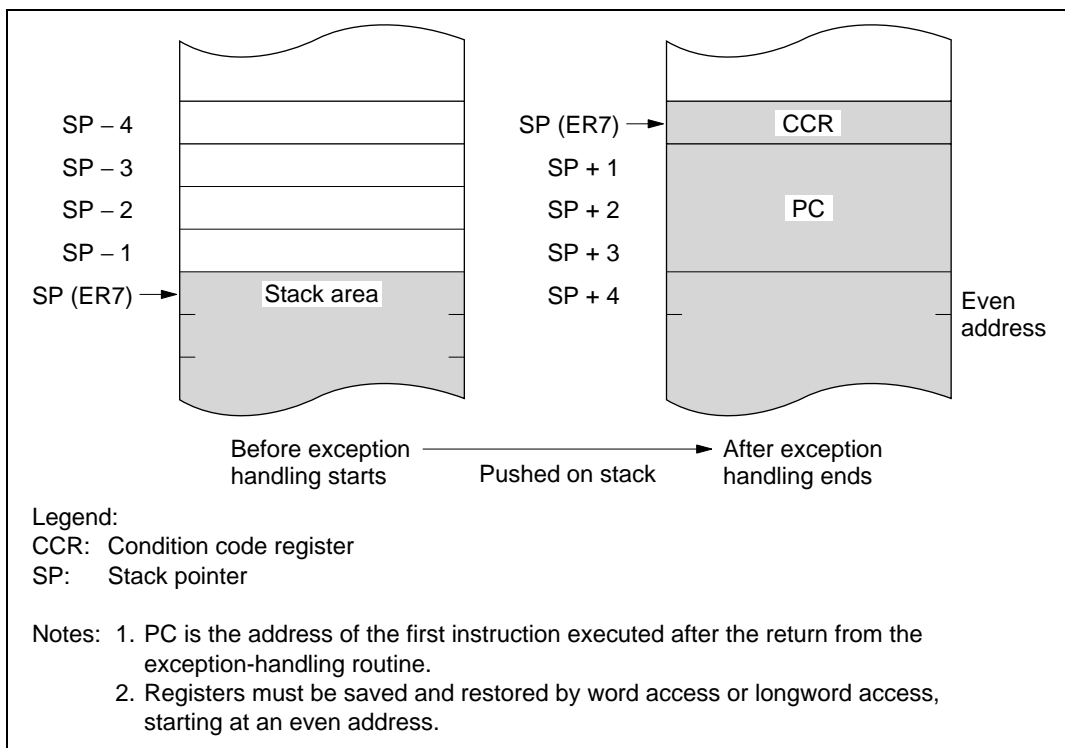

Figure 2.14 Stack Structure after Exception Handling

2.8.5 Bus-Released State

In this state the bus is released to a bus master other than the CPU, in response to a bus request. The bus masters other than the CPU are the DMA controller, the refresh controller, and an external bus master. While the bus is released, the CPU halts except for internal operations. Interrupt requests are not accepted. For details see section 6.3.7, Bus Arbiter Operation.

2.8.6 Reset State

When the $\overline{\text{RES}}$ input goes low all current processing stops and the CPU enters the reset state. The I bit in the condition code register is set to 1 by a reset. All interrupts are masked in the reset state. Reset exception handling starts when the $\overline{\text{RES}}$ signal changes from low to high.

The reset state can also be entered by a watchdog timer overflow. For details see section 12, Watchdog Timer.

2.8.7 Power-Down State

In the power-down state the CPU stops operating to conserve power. There are three modes: sleep mode, software standby mode, and hardware standby mode.

Sleep Mode: A transition to sleep mode is made if the SLEEP instruction is executed while the SSBY bit is cleared to 0 in the system control register (SYSCR). CPU operations stop immediately after execution of the SLEEP instruction, but the contents of CPU registers are retained.

Software Standby Mode: A transition to software standby mode is made if the SLEEP instruction is executed while the SSBY bit is set to 1 in SYSCR. The CPU and clock halt and all on-chip supporting modules stop operating. The on-chip supporting modules are reset, but as long as a specified voltage is supplied the contents of CPU registers and on-chip RAM are retained. The I/O ports also remain in their existing states.

Hardware Standby Mode: A transition to hardware standby mode is made when the $\overline{\text{STBY}}$ input goes low. As in software standby mode, the CPU and all clocks halt and the on-chip supporting modules are reset, but as long as a specified voltage is supplied, on-chip RAM contents are retained.

For further information see section 20, Power-Down State.

2.9 Basic Operational Timing

2.9.1 Overview

The H8/300H CPU operates according to the system clock (ϕ). The interval from one rise of the system clock to the next rise is referred to as a “state.” A memory cycle or bus cycle consists of two or three states. The CPU uses different methods to access on-chip memory, the on-chip supporting modules, and the external address space. Access to the external address space can be controlled by the bus controller.

2.9.2 On-Chip Memory Access Timing

On-chip memory is accessed in two states. The data bus is 16 bits wide, permitting both byte and word access. Figure 2.15 shows the on-chip memory access cycle. Figure 2.16 indicates the pin states.

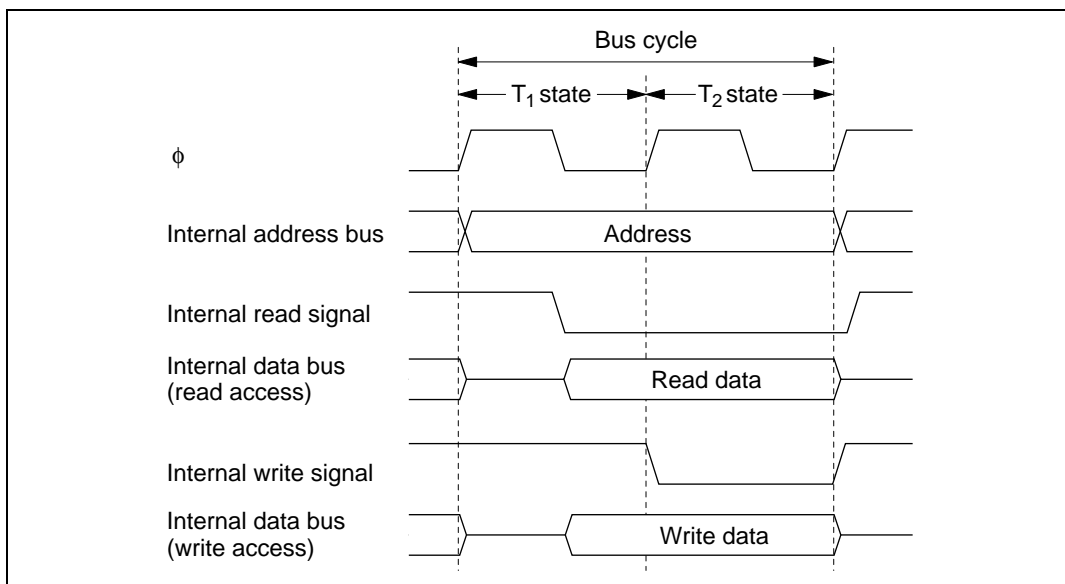

Figure 2.15 On-Chip Memory Access Cycle

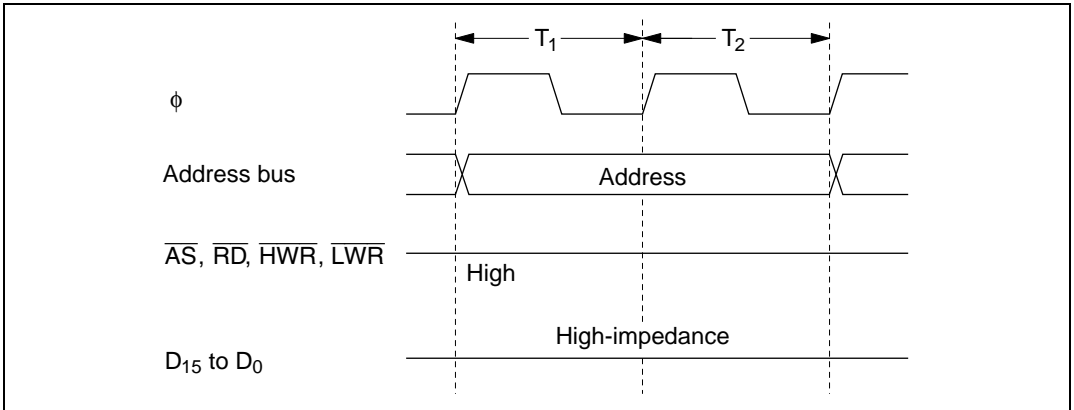

Figure 2.16 Pin States during On-Chip Memory Access

2.9.3 On-Chip Supporting Module Access Timing

The on-chip supporting modules are accessed in three states. The data bus is 8 or 16 bits wide, depending on the register being accessed. Figure 2.17 shows the on-chip supporting module access timing. Figure 2.18 indicates the pin states.

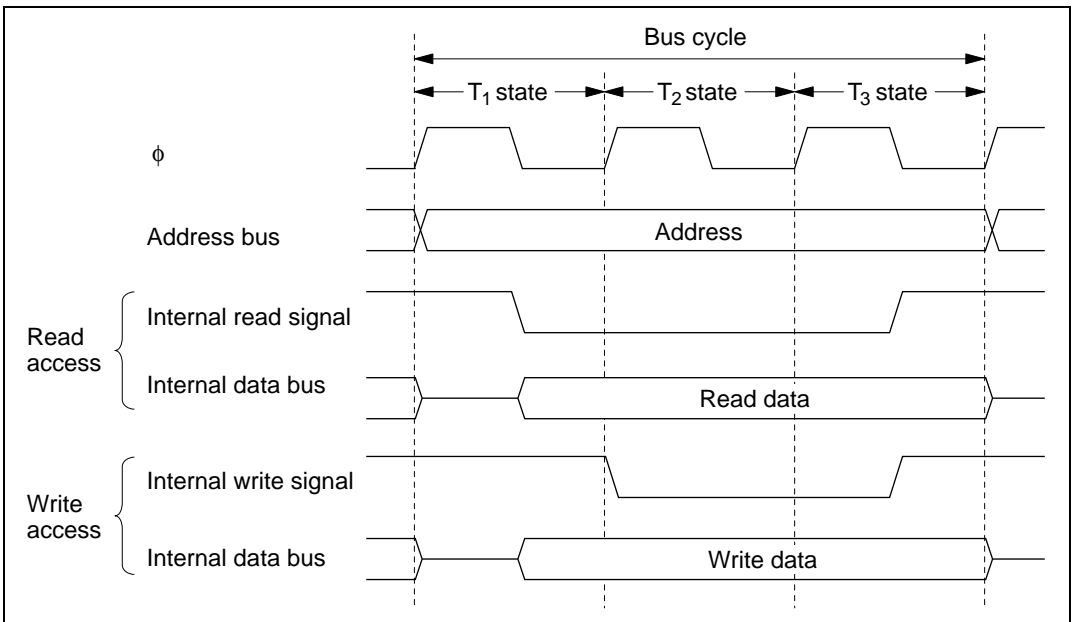

Figure 2.17 Access Cycle for On-Chip Supporting Modules

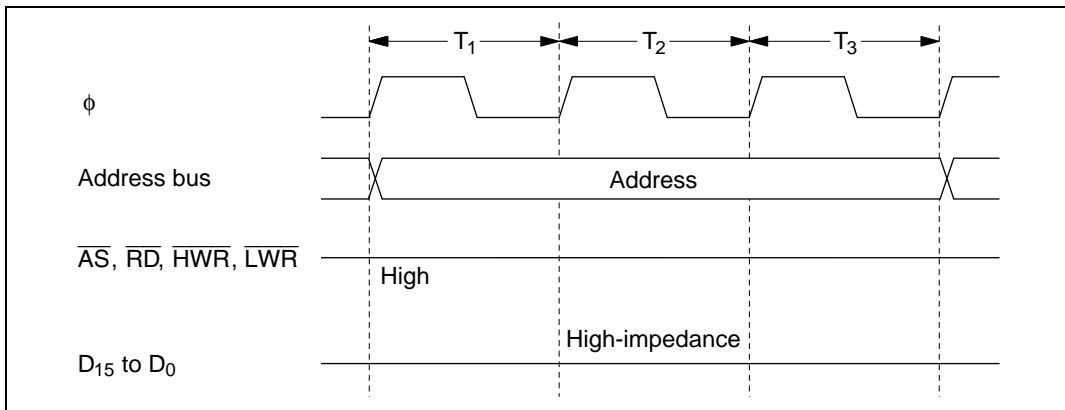

Figure 2.18 Pin States during Access to On-Chip Supporting Modules

2.9.4 Access to External Address Space

The external address space is divided into eight areas (areas 0 to 7). Bus-controller settings determine whether each area is accessed via an 8-bit or 16-bit bus, and whether it is accessed in two or three states. For details see section 6, Bus Controller.

Section 3 MCU Operating Modes

3.1 Overview

3.1.1 Operating Mode Selection

The H8/3048B Group has seven operating modes (modes 1 to 7) that are selected by the mode pins (MD_2 to MD_0) as indicated in table 3.1. The input at these pins determines the size of the address space and the initial bus mode.

Table 3.1 Operating Mode Selection

Operating Mode	Mode Pins			Address Space	Description		
	MD_2	MD_1	MD_0		Initial Bus Mode* ¹	On-Chip ROM	On-Chip RAM
—	0	0	0	—	—	—	—
Mode 1	0	0	1	Expanded mode	8 bits	Disabled	Enabled* ²
Mode 2	0	1	0	Expanded mode	16 bits	Disabled	Enabled* ²
Mode 3	0	1	1	Expanded mode	8 bits	Disabled	Enabled* ²
Mode 4	1	0	0	Expanded mode	16 bits	Disabled	Enabled* ²
Mode 5	1	0	1	Expanded mode	8 bits	Enabled	Enabled* ²
Mode 6	1	1	0	Expanded mode	8 bits	Enabled	Enabled* ²
Mode 7	1	1	1	Single-chip advanced mode	—	Enabled	Enabled

- Notes: 1. In modes 1 to 6, an 8-bit or 16-bit data bus can be selected on a per-area basis by settings made in the area bus width control register (ABWCR). For details see section 6, Bus Controller.
2. If the RAME bit in SYSCR is cleared to 0, these addresses become external addresses.

For the address space size there are two choices: 1 Mbyte or 16 Mbytes. The external data bus is either 8 or 16 bits wide depending on ABWCR settings. If 8-bit access is selected for all areas, the external data bus is 8 bits wide. For details see section 6, Bus Controller.

Modes 1 to 4 are externally expanded modes that enable access to external memory and peripheral devices and disable access to the on-chip ROM. Modes 1 and 2 support a maximum address space of 1 Mbyte. Modes 3 and 4 support a maximum address space of 16 Mbytes.

Modes 5 and 6 are externally expanded modes that enable access to external memory and peripheral devices and also enable access to the on-chip ROM. Mode 5 supports a maximum address space of 1 Mbyte. Mode 6 supports a maximum address space of 16 Mbytes.

Mode 7 is a single-chip mode that operates using the on-chip ROM, RAM, and internal I/O registers, and makes all I/O ports available. Mode 7 supports a 1-Mbyte address space.

The H8/3048B Group can be used only in modes 1 to 7. The inputs at the mode pins must select one of these seven modes. The inputs at the mode pins must not be changed during operation.

3.1.2 Register Configuration

The H8/3048B Group has a mode control register (MDCR) that indicates the inputs at the mode pins (MD_2 to MD_0), and a system control register (SYSCR). Table 3.2 summarizes these registers.

Table 3.2 Registers

Address*	Name	Abbreviation	R/W	Initial Value
H'FFF1	Mode control register	MDCR	R	Undetermined
H'FFF2	System control register	SYSCR	R/W	H'0B

Note: * The lower 16 bits of the address are indicated.

3.2 Mode Control Register (MDCR)

MDCR is an 8-bit read-only register that indicates the current operating mode of the H8/3048B Group.

Bit	7	6	5	4	3	2	1	0	
	—	—	—	—	—	MDS2	MDS1	MDS0	
Initial value	1	1	0	0	0	—*	—*	—*	
Read/Write	—	—	—	—	—	R	R	R	
	Reserved bits		Reserved bits			Mode select 2 to 0			
							Bits indicating the current operating mode		

Note: * Determined by pins MD_2 to MD_0 .

Bits 7 and 6—Reserved: Read-only bits, always read as 1.

Bits 5 to 3—Reserved: Read-only bits, always read as 0.

Bits 2 to 0—Mode Select 2 to 0 (MDS2 to MDS0): These bits indicate the logic levels at pins MD₂ to MD₀ (the current operating mode). MDS2 to MDS0 correspond to MD₂ to MD₀. MDS2 to MDS0 are read-only bits. The mode pin (MD₂ to MD₀) levels are latched into these bits when MDCR is read.

Note: For the flash memory version with single power supply (H8/3048F-ONE), flash memory can be written to in the boot mode. In the boot mode, the inverted value of the MD2 signal is set to bit MDS2.

3.3 System Control Register (SYSCR)

SYSCR is an 8-bit register that controls the operation of the H8/3048B Group.

Bit	7	6	5	4	3	2	1	0
	SSBY	STS2	STS1	STS0	UE	NMIEG	—	RAME
Initial value	0	0	0	0	1	0	1	1
Read/Write	R/W	R/W	R/W	R/W	R/W	R/W	—	R/W

RAM enable
Enables or disables on-chip RAM

Reserved bit

NMI edge select
Selects the valid edge of the NMI input

User bit enable
Selects whether to use the UI bit in CCR as a user bit or an interrupt mask bit

Standby timer select 2 to 0
These bits select the waiting time at recovery from software standby mode

Software standby
Enables transition to software standby mode

Bit 7—Software Standby (SSBY): Enables transition to software standby mode. (For further information about software standby mode see section 20, Power-Down State.)

When software standby mode is exited by an external interrupt, this bit remains set to 1. To clear this bit, write 0.

Bit 7: SSBY	Description
0	SLEEP instruction causes transition to sleep mode (Initial value)
1	SLEEP instruction causes transition to software standby mode

Bits 6 to 4—Standby Timer Select (STS2 to STS0): These bits select the length of time the CPU and on-chip supporting modules wait for the internal clock oscillator to settle when software standby mode is exited by an external interrupt. When using a crystal oscillator, set these bits so that the waiting time will be at least 7 ms at the system clock rate. For further information about waiting time selection, see section 20.4.3, Selection of Waiting Time for Exit from Software Standby Mode.

Bit 6: STS2	Bit 5: STS1	Bit 4: STS0	Description
0	0	0	Waiting time = 8,192 states (Initial value)
		1	Waiting time = 16,384 states
	1	0	Waiting time = 32,768 states
		1	Waiting time = 65,536 states
1	0	0	Waiting time = 131,072 states
		1	Waiting time = 262,144 states
	1	0	Waiting time = 1,024 states
		1	Illegal setting

Bit 3—User Bit Enable (UE): Selects whether to use the UI bit in the condition code register as a user bit or an interrupt mask bit.

Bit 3: UE	Description
0	UI bit in CCR is used as an interrupt mask bit
1	UI bit in CCR is used as a user bit (Initial value)

Bit 2—NMI Edge Select (NMIEG): Selects the valid edge of the NMI input.

Bit 2: NMIEG	Description
0	An interrupt is requested at the falling edge of NMI (Initial value)
1	An interrupt is requested at the rising edge of NMI

Bit 1—Reserved: Read-only bit, always read as 1.

Bit 0—RAM Enable (RAME): Enables or disables the on-chip RAM. The RAME bit is initialized by the rising edge of the $\overline{\text{RES}}$ signal. It is not initialized in software standby mode.

Bit 0: RAME	Description
0	On-chip RAM is disabled
1	On-chip RAM is enabled (Initial value)

3.4 Operating Mode Descriptions

3.4.1 Mode 1

Ports 1, 2, and 5 function as address pins A_{19} to A_0 , permitting access to a maximum 1-Mbyte address space. The initial bus mode after a reset is 8 bits, with 8-bit access to all areas. If at least one area is designated for 16-bit access in ABWCR, the bus mode switches to 16 bits.

3.4.2 Mode 2

Ports 1, 2, and 5 function as address pins A_{19} to A_0 , permitting access to a maximum 1-Mbyte address space. The initial bus mode after a reset is 16 bits, with 16-bit access to all areas. If all areas are designated for 8-bit access in ABWCR, the bus mode switches to 8 bits.

3.4.3 Mode 3

Ports 1, 2, and 5 and part of port A function as address pins A_{23} to A_0 , permitting access to a maximum 16-Mbyte address space. The initial bus mode after a reset is 8 bits, with 8-bit access to all areas. If at least one area is designated for 16-bit access in ABWCR, the bus mode switches to 16 bits. A_{23} to A_{21} are valid when 0 is written in bits 7 to 5 of the bus release control register (BRCR). (In this mode A_{20} is always used for address output.)

3.4.4 Mode 4

Ports 1, 2, and 5 and part of port A function as address pins A_{23} to A_0 , permitting access to a maximum 16-Mbyte address space. The initial bus mode after a reset is 16 bits, with 16-bit access to all areas. If all areas are designated for 8-bit access in ABWCR, the bus mode switches to 8 bits. A_{23} to A_{21} are valid when 0 is written in bits 7 to 5 of BRCCR. (In this mode A_{20} is always used for address output.)

3.4.5 Mode 5

Ports 1, 2, and 5 can function as address pins A_{19} to A_0 , permitting access to a maximum 1-Mbyte address space, but following a reset they are input ports. To use ports 1, 2, and 5 as an address bus, the corresponding bits in their data direction registers (P1DDR, P2DDR, and P5DDR) must be set to 1. The initial bus mode after a reset is 8 bits, with 8-bit access to all areas. If at least one area is designated for 16-bit access in ABWCR, the bus mode switches to 16 bits.

3.4.6 Mode 6

Ports 1, 2, and 5 and part of port A function as address pins A_{23} to A_0 , permitting access to a maximum 16-Mbyte address space, but following a reset they are input ports. To use ports 1, 2, and 5 as an address bus, the corresponding bits in their data direction registers (P1DDR, P2DDR, and P5DDR) must be set to 1. For A_{23} to A_{21} output, clear bits 7 to 5 of BRCCR to 0. (In this mode A_{20} is always used for address output.)

The initial bus mode after a reset is 8 bits, with 8-bit access to all areas. If at least one area is designated for 16-bit access in ABWCR, the bus mode switches to 16 bits.

3.4.7 Mode 7

This mode operates using the on-chip ROM, RAM, and internal I/O registers. All I/O ports are available. Mode 7 supports a 1-Mbyte address space.

3.5 Pin Functions in Each Operating Mode

The pin functions of ports 1 to 5 and port A vary depending on the operating mode. Table 3.3 indicates their functions in each operating mode.

Table 3.3 Pin Functions in Each Mode

Port	Mode 1	Mode 2	Mode 3	Mode 4	Mode 5	Mode 6	Mode 7
Port 1	A ₇ to A ₀	A ₇ to A ₀	A ₇ to A ₀	A ₇ to A ₀	P1 ₇ to P1 ₀ ^{*2}	P1 ₇ to P1 ₀ ^{*2}	P1 ₇ to P1 ₀
Port 2	A ₁₅ to A ₈	A ₁₅ to A ₈	A ₁₅ to A ₈	A ₁₅ to A ₈	P2 ₇ to P2 ₀ ^{*2}	P2 ₇ to P2 ₀ ^{*2}	P2 ₇ to P2 ₀
Port 3	D ₁₅ to D ₈	D ₁₅ to D ₈	D ₁₅ to D ₈	D ₁₅ to D ₈	D ₁₅ to D ₈	D ₁₅ to D ₈	P3 ₇ to P3 ₀
Port 4	P4 ₇ to P4 ₀ ^{*1}	D ₇ to D ₀ ^{*1}	P4 ₇ to P4 ₀ ^{*1}	D ₇ to D ₀ ^{*1}	P4 ₇ to P4 ₀ ^{*1}	P4 ₇ to P4 ₀ ^{*1}	P4 ₇ to P4 ₀
Port 5	A ₁₉ to A ₁₆	A ₁₉ to A ₁₆	A ₁₉ to A ₁₆	A ₁₉ to A ₁₆	P5 ₃ to P5 ₀ ^{*2}	P5 ₃ to P5 ₀ ^{*2}	P5 ₃ to P5 ₀
Port A	PA ₇ to PA ₄	PA ₇ to PA ₄	PA ₇ to PA ₅ ^{*3} , A ₂₀	PA ₇ to PA ₅ ^{*3} , A ₂₀	PA ₇ to PA ₄	PA ₇ to PA ₅ , A ₂₀ ^{*3}	PA ₇ to PA ₄

- Notes: 1. Initial state. The bus mode can be switched by settings in ABWCR. These pins function as P4₇ to P4₀ in 8-bit bus mode, and as D₇ to D₀ in 16-bit bus mode.
2. Initial state. These pins become address output pins when the corresponding bits in the data direction registers (P1DDR, P2DDR, P5DDR) are set to 1.
3. Initial state. A₂₀ is always an address output pin. PA₇ to PA₅ are switched over to A₂₃ to A₂₁ output by writing 0 in bits 7 to 5 of BRCCR.

3.6 Memory Map in Each Operating Mode

Figure 3.1 shows a memory map of the H8/3048B Group. The address space is divided into eight areas.

The initial bus mode differs between modes 1 and 2, and also between modes 3 and 4.

The address locations of the on-chip RAM and internal I/O registers differ between the 1-Mbyte modes (modes 1, 2, 5, and 7) and 16-Mbyte modes (modes 3, 4, and 6). The address range specifiable by the CPU in the 8- and 16-bit absolute addressing modes (@aa:8 and @aa:16) also differs.

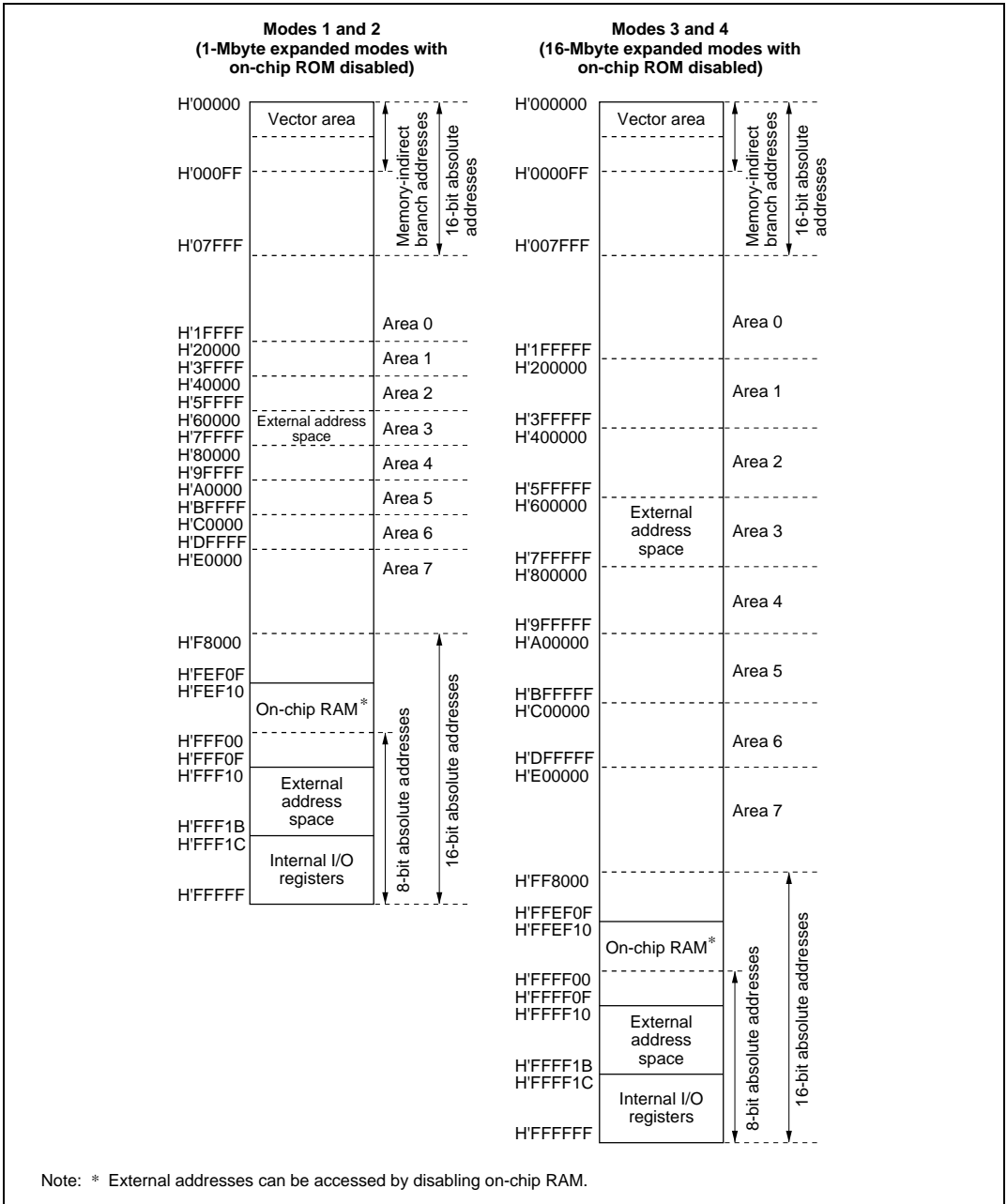

Figure 3.1 H8/3048B Group Memory Map in Each Operating Mode

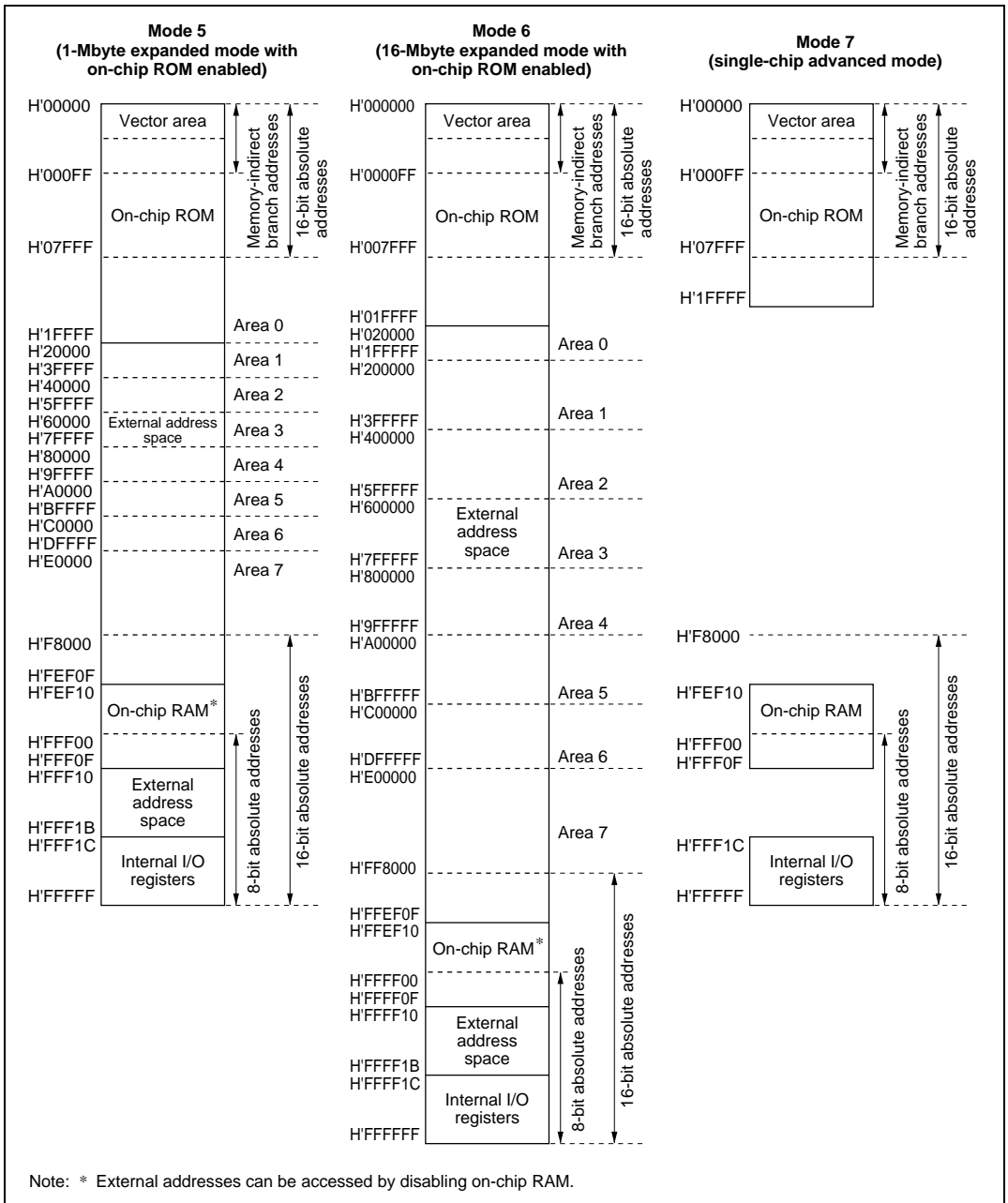

Figure 3.1 H8/3048B Group Memory Map in Each Operating Mode (cont)

Section 4 Exception Handling

4.1 Overview

4.1.1 Exception Handling Types and Priority

As table 4.1 indicates, exception handling may be caused by a reset, trap instruction, or interrupt. Exception handling is prioritized as shown in table 4.1. If two or more exceptions occur simultaneously, they are accepted and processed in priority order. Trap instruction exceptions are accepted at all times in the program execution state.

Table 4.1 Exception Types and Priority

Priority	Exception Type	Start of Exception Handling
High ↑	Reset	Starts immediately after a low-to-high transition at the RES pin
	Interrupt	Interrupt requests are handled when execution of the current instruction or handling of the current exception is completed
Low	Trap instruction (TRAPA)	Started by execution of a trap instruction (TRAPA)

4.1.2 Exception Handling Operation

Exceptions originate from various sources. Trap instructions and interrupts are handled as follows.

1. The program counter (PC) and condition code register (CCR) are pushed onto the stack.
2. The CCR interrupt mask bit is set to 1.
3. A vector address corresponding to the exception source is generated, and program execution starts from the address indicated in that address.

Note: For a reset exception, steps 2 and 3 above are carried out.

4.1.3 Exception Vector Table

The exception sources are classified as shown in figure 4.1. Different vectors are assigned to different exception sources. Table 4.2 lists the exception sources and their vector addresses.

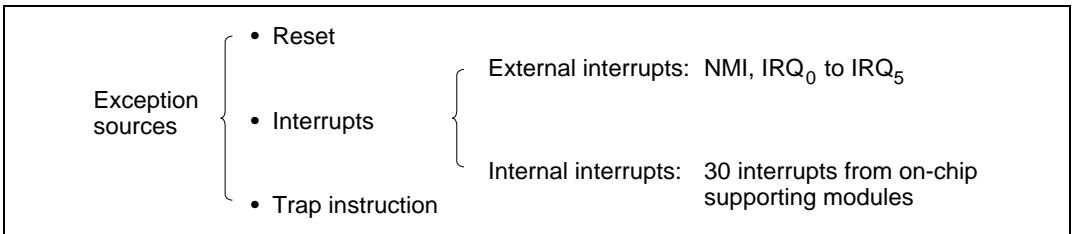

Figure 4.1 Exception Sources

Table 4.2 Exception Vector Table

Exception Source	Vector Number	Vector Address^{*1}
Reset	0	H'0000 to H'0003
Reserved for system use	1	H'0004 to H'0007
	2	H'0008 to H'000B
	3	H'000C to H'000F
	4	H'0010 to H'0013
	5	H'0014 to H'0017
	6	H'0018 to H'001B
External interrupt (NMI)	7	H'001C to H'001F
Trap instruction (4 sources)	8	H'0020 to H'0023
	9	H'0024 to H'0027
	10	H'0028 to H'002B
	11	H'002C to H'002F
External interrupt IRQ ₀	12	H'0030 to H'0033
External interrupt IRQ ₁	13	H'0034 to H'0037
External interrupt IRQ ₂	14	H'0038 to H'003B
External interrupt IRQ ₃	15	H'003C to H'003F
External interrupt IRQ ₄	16	H'0040 to H'0043
External interrupt IRQ ₅	17	H'0044 to H'0047
Reserved for system use	18	H'0048 to H'004B
	19	H'004C to H'004F
Internal interrupts ^{*2}	20	H'0050 to H'0053
	to	to
	60	H'00F0 to H'00F3

Notes: 1. Lower 16 bits of the address.

2. For the internal interrupt vectors, see section 5.3.3, Interrupt Vector Table.

4.2 Reset

4.2.1 Overview

A reset is the highest-priority exception. When the $\overline{\text{RES}}$ pin goes low, all processing halts and the chip enters the reset state. A reset initializes the internal state of the CPU and the registers of the on-chip supporting modules. Reset exception handling begins when the $\overline{\text{RES}}$ pin changes from low to high.

The chip can also be reset by overflow of the watchdog timer. For details see section 12, Watchdog Timer.

4.2.2 Reset Sequence

The chip enters the reset state when the $\overline{\text{RES}}$ pin goes low.

To ensure that the chip is reset properly, hold the $\overline{\text{RES}}$ pin low for at least 20 ms at power-up. To reset the chip during operation, hold the $\overline{\text{RES}}$ pin low for at least 20 system clock (ϕ) cycles. See appendix D.2, Pin States at Reset, for the states of the pins in the reset state.

When the $\overline{\text{RES}}$ pin goes high after being held low for the necessary time, the chip starts reset exception handling as follows.

- The internal state of the CPU and the registers of the on-chip supporting modules are initialized, and the I bit is set to 1 in CCR.
- The contents of the reset vector address (H'0000 to H'0003) are read, and program execution starts from the address indicated in the vector address.

Figure 4.2 shows the reset sequence in modes 1 and 3. Figure 4.3 shows the reset sequence in modes 2 and 4. Figure 4.4 shows the reset sequence in modes 5, 6, and 7.

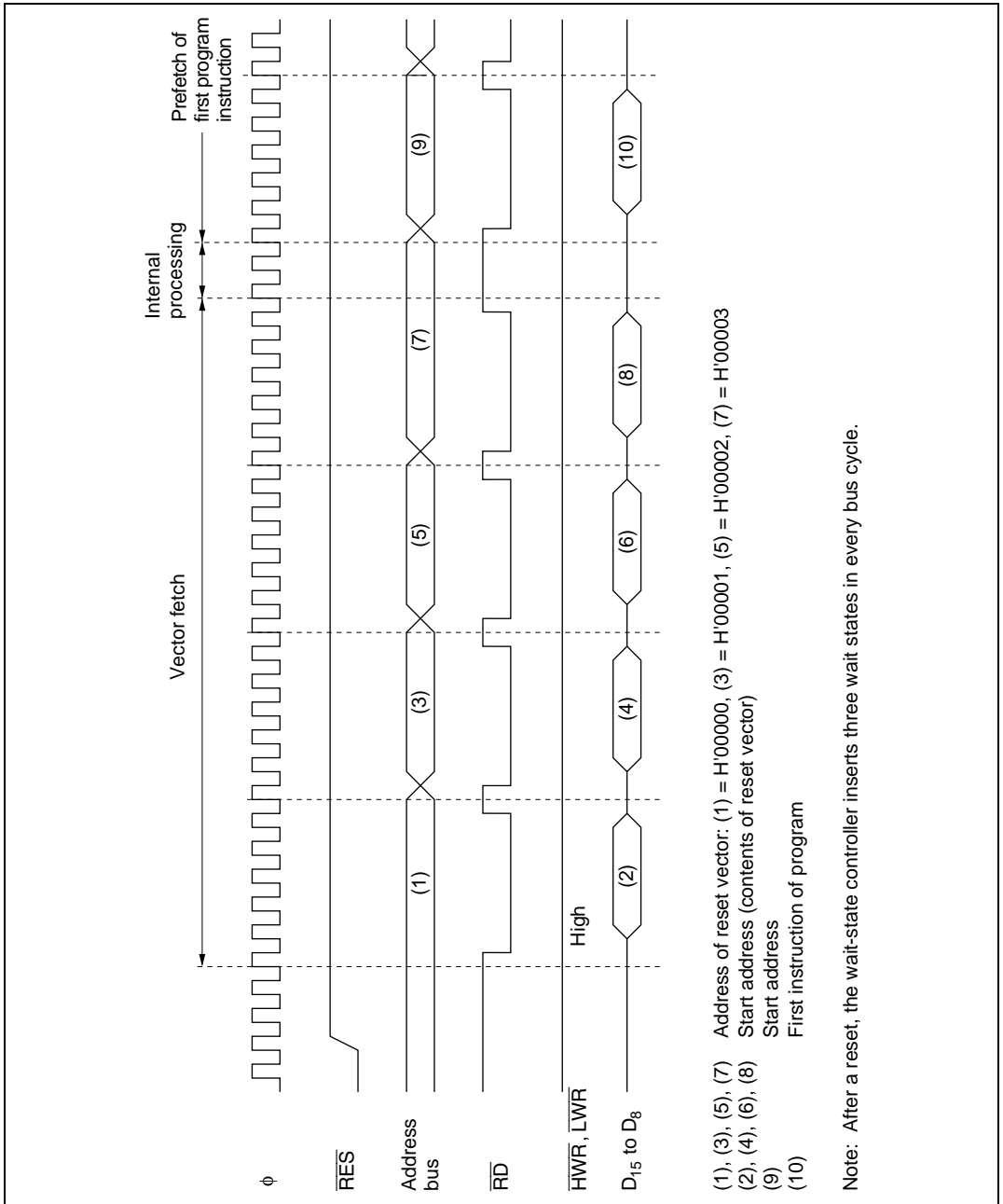

Figure 4.2 Reset Sequence (Modes 1 and 3)

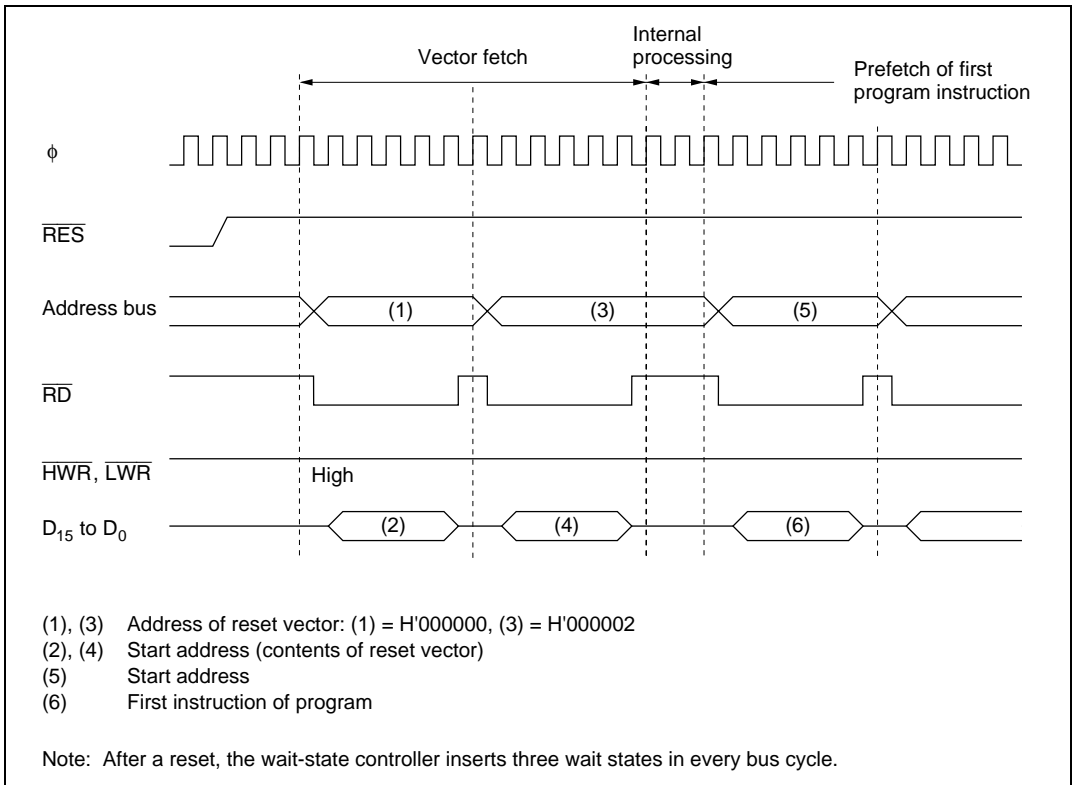

Figure 4.3 Reset Sequence (Modes 2 and 4)

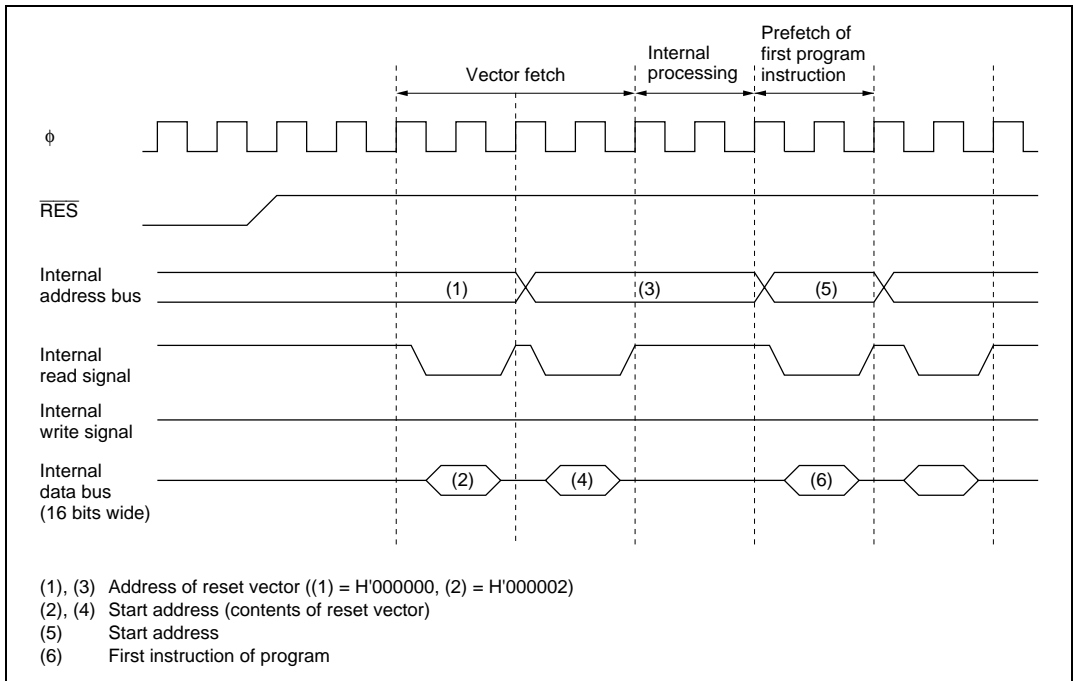

Figure 4.4 Reset Sequence (Modes 5, 6, and 7)

4.2.3 Interrupts after Reset

If an interrupt is accepted after a reset but before the stack pointer (SP) is initialized, PC and CCR will not be saved correctly, leading to a program crash. To prevent this, all interrupt requests, including NMI, are disabled immediately after a reset. The first instruction of the program is always executed immediately after the reset state ends. This instruction should initialize the stack pointer (example: `MOV.L #xx:32, SP`).

4.3 Interrupts

Interrupt exception handling can be requested by seven external sources (NMI, IRQ₀ to IRQ₅) and 30 internal sources in the on-chip supporting modules. Figure 4.5 classifies the interrupt sources and indicates the number of interrupts of each type.

The on-chip supporting modules that can request interrupts are the watchdog timer (WDT), refresh controller, 16-bit integrated timer unit (ITU), DMA controller (DMAC), serial communication interface (SCI), and A/D converter. Each interrupt source has a separate vector address.

NMI is the highest-priority interrupt and is always accepted*. Interrupts are controlled by the interrupt controller. The interrupt controller can assign interrupts other than NMI to two priority levels, and arbitrate between simultaneous interrupts. Interrupt priorities are assigned in interrupt priority registers A and B (IPRA and IPRB) in the interrupt controller.

For details on interrupts see section 5, Interrupt Controller.

Note: * For the H8/3048F-ONE (single power supply with flash memory), the NMI input may be prohibited. For details, refer to section 18.8.4, NMI Input Disable Conditions.

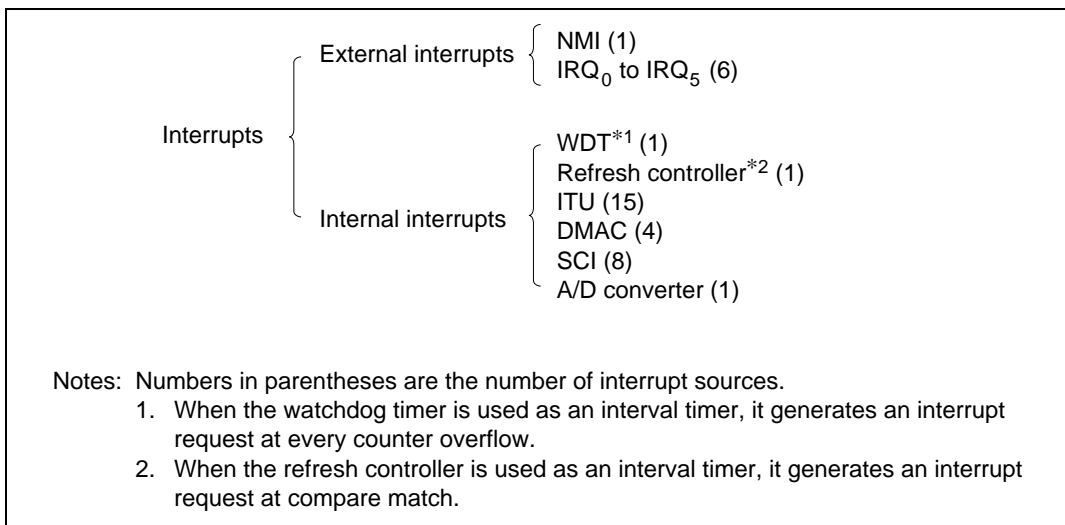

Figure 4.5 Interrupt Sources and Number of Interrupts

4.4 Trap Instruction

Trap instruction exception handling starts when a TRAPA instruction is executed. If the UE bit is set to 1 in the system control register (SYSCR), the exception handling sequence sets the I bit to 1 in CCR. If the UE bit is 0, the I and UI bits are both set to 1. The TRAPA instruction fetches a start address from a vector table entry corresponding to a vector number from 0 to 3, which is specified in the instruction code.

4.5 Stack Status after Exception Handling

Figure 4.6 shows the stack after completion of trap instruction exception handling and interrupt exception handling.

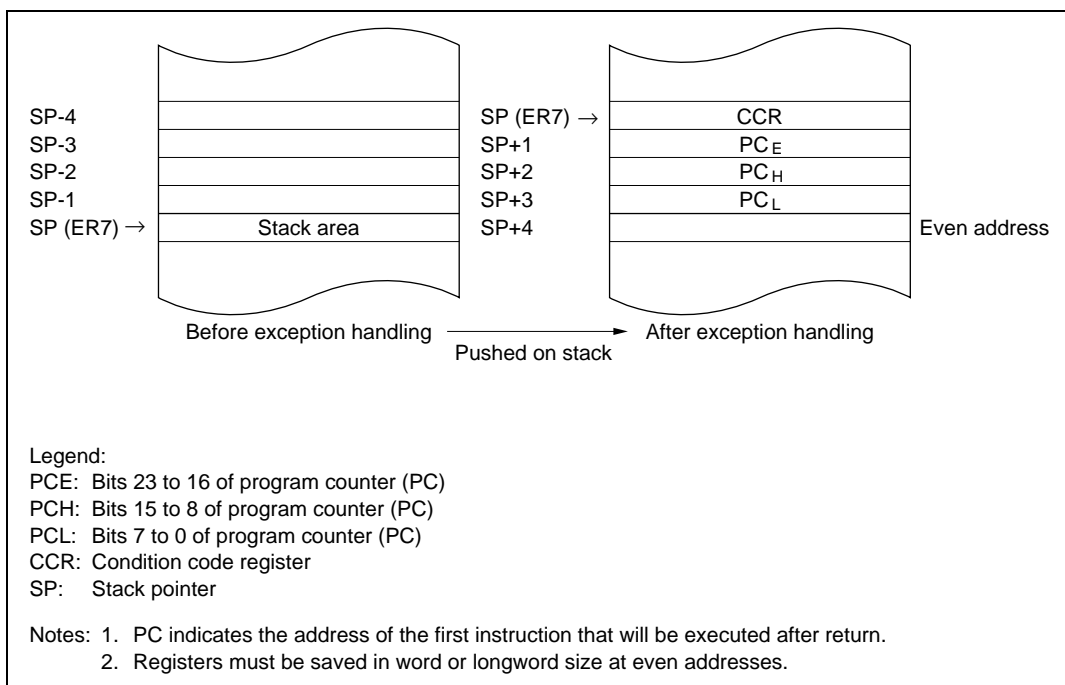

Figure 4.6 Stack after Completion of Exception Handling

4.6 Notes on Stack Usage

When accessing word data or longword data, the H8/3048B Group regards the lowest address bit as 0. The stack should always be accessed by word access or longword access, and the value of the stack pointer (SP:ER7) should always be kept even. Use the following instructions to save registers:

```
PUSH.W Rn    (or MOV.W Rn, @-SP)
PUSH.L ERn   (or MOV.L ERn, @-SP)
```

Use the following instructions to restore registers:

```
POP.W Rn     (or MOV.W @SP+, Rn)
POP.L ERn    (or MOV.L @SP+, ERn)
```

Setting SP to an odd value may lead to a malfunction. Figure 4.7 shows an example of what happens when the SP value is odd.

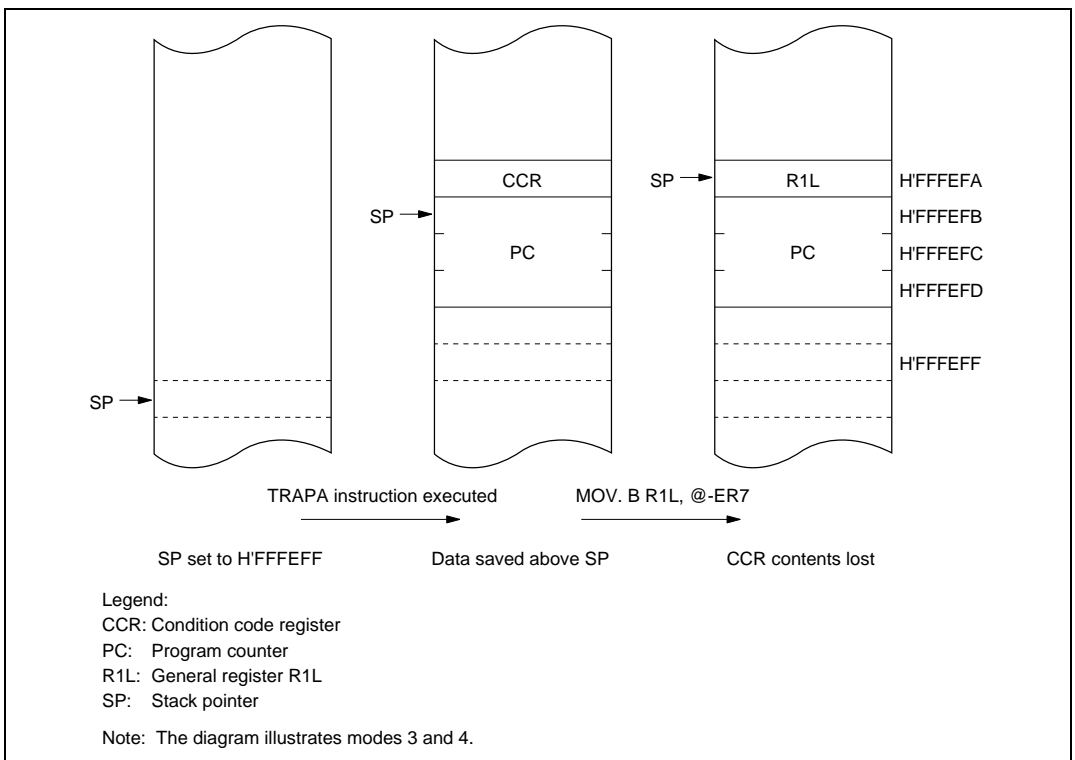

Figure 4.7 Operation when SP Value Is Odd

Section 5 Interrupt Controller

5.1 Overview

5.1.1 Features

The interrupt controller has the following features:

- Interrupt priority registers (IPRs) for setting interrupt priorities
Interrupts other than NMI can be assigned to two priority levels on a module-by-module basis in interrupt priority registers A and B (IPRA and IPRB).
- Three-level masking by the I and UI bits in the CPU condition code register (CCR)
- Independent vector addresses
All interrupts are independently vectored; the interrupt service routine does not have to identify the interrupt source.
- Seven external interrupt pins
NMI has the highest priority and is always accepted*; either the rising or falling edge can be selected. For each of IRQ_0 to IRQ_5 , sensing of the falling edge or level sensing can be selected independently.

Note: * For the H8/3048F-ONE (single power supply with flash memory), the NMI input may be prohibited. For details, refer to section 18.8.4, NMI Input Disable Conditions.

5.1.2 Block Diagram

Figure 5.1 shows a block diagram of the interrupt controller.

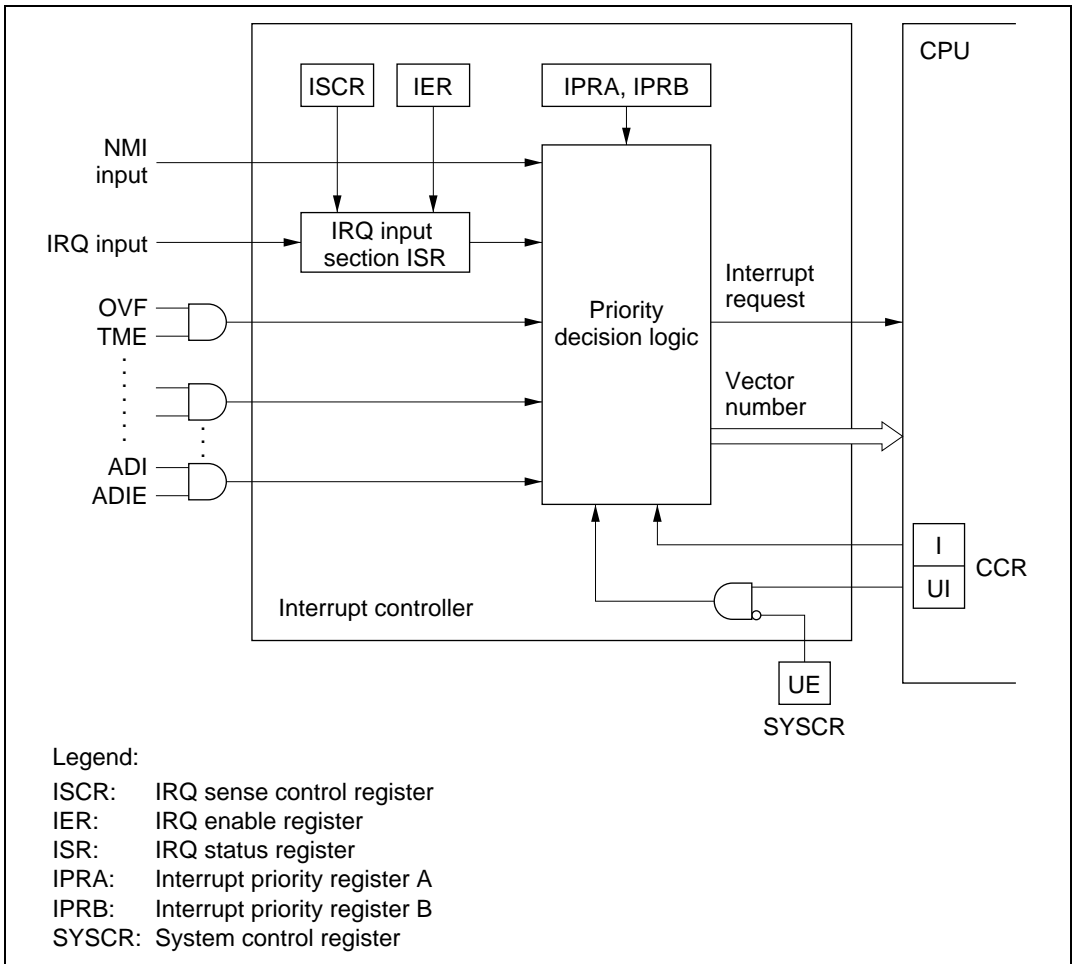

Figure 5.1 Interrupt Controller Block Diagram

5.1.3 Pin Configuration

Table 5.1 lists the interrupt pins.

Table 5.1 Interrupt Pins

Name	Abbreviation	I/O	Function
Nonmaskable interrupt	NMI	Input	Nonmaskable interrupt*, rising edge or falling edge selectable
External interrupt request 5 to 0	$\overline{\text{IRQ}}_5$ to $\overline{\text{IRQ}}_0$	Input	Maskable interrupts, falling edge or level sensing selectable

Note: * For the H8/3048F-ONE (single power supply with flash memory), the NMI input may be prohibited. For details, refer to section 18.8.4, NMI Input Disable Conditions.

5.1.4 Register Configuration

Table 5.2 lists the registers of the interrupt controller.

Table 5.2 Interrupt Controller Registers

Address* ¹	Name	Abbreviation	R/W	Initial Value
H'FFF2	System control register	SYSCR	R/W	H'0B
H'FFF4	IRQ sense control register	ISCR	R/W	H'00
H'FFF5	IRQ enable register	IER	R/W	H'00
H'FFF6	IRQ status register	ISR	R/(W)* ²	H'00
H'FFF8	Interrupt priority register A	IPRA	R/W	H'00
H'FFF9	Interrupt priority register B	IPRB	R/W	H'00

Notes: 1. Lower 16 bits of the address.
2. Only 0 can be written, to clear flags.

5.2 Register Descriptions

5.2.1 System Control Register (SYSCR)

SYSCR is an 8-bit readable/writable register that controls software standby mode, selects the action of the UI bit in CCR, selects the NMI edge, and enables or disables the on-chip RAM.

Only bits 3 and 2 are described here. For the other bits, see section 3.3, System Control Register (SYSCR).

SYSCR is initialized to H'0B by a reset and in hardware standby mode. It is not initialized in software standby mode.

Bit	7	6	5	4	3	2	1	0
	SSBY	STS2	STS1	STS0	UE	NMIEG	—	RAME
Initial value	0	0	0	0	1	0	1	1
Read/Write	R/W	R/W	R/W	R/W	R/W	R/W	—	R/W

Software standby

Standby timer select 2 to 0

User bit enable
Selects whether to use the UI bit in CCR as a user bit or interrupt mask bit

NMI edge select
Selects the NMI input edge

Reserved bit

RAM enable

Bit 3—User Bit Enable (UE): Selects whether to use the UI bit in CCR as a user bit or an interrupt mask bit.

Bit 3: UE	Description
0	UI bit in CCR is used as interrupt mask bit
1	UI bit in CCR is used as user bit (Initial value)

Bit 2—NMI Edge Select (NMIEG): Selects the NMI input edge.

Bit 2: NMIEG	Description
0	Interrupt is requested at falling edge of NMI input (Initial value)
1	Interrupt is requested at rising edge of NMI input

5.2.2 Interrupt Priority Registers A and B (IPRA, IPRB)

IPRA and IPRB are 8-bit readable/writable registers that control interrupt priority.

Interrupt Priority Register A (IPRA)

IPRA is an 8-bit readable/writable register in which interrupt priority levels can be set.

Bit	7	6	5	4	3	2	1	0
	IPRA7	IPRA6	IPRA5	IPRA4	IPRA3	IPRA2	IPRA1	IPRA0
Initial value	0	0	0	0	0	0	0	0
Read/Write	R/W	R/W	R/W	R/W	R/W	R/W	R/W	R/W

Priority level A0
Selects the priority level of ITU channel 2 interrupt requests

Priority level A1
Selects the priority level of ITU channel 1 interrupt requests

Priority level A2
Selects the priority level of ITU channel 0 interrupt requests

Priority level A3
Selects the priority level of WDT and refresh controller interrupt requests

Priority level A4
Selects the priority level of IRQ₄ and IRQ₅ interrupt requests

Priority level A5
Selects the priority level of IRQ₂ and IRQ₃ interrupt requests

Priority level A6
Selects the priority level of IRQ₁ interrupt requests

Priority level A7
Selects the priority level of IRQ₀ interrupt requests

Priority level A0

Priority level A1

Priority level A2

Priority level A3

Priority level A4

Priority level A5

Priority level A6

Priority level A7

IPRA is initialized to H'00 by a reset and in hardware standby mode.

Bit 7—Priority Level A7 (IPRA7): Selects the priority level of IRQ_0 interrupt requests.

Bit 7: IPRA7	Description
0	IRQ_0 interrupt requests have priority level 0 (low priority) (Initial value)
1	IRQ_0 interrupt requests have priority level 1 (high priority)

Bit 6—Priority Level A6 (IPRA6): Selects the priority level of IRQ_1 interrupt requests.

Bit 6: IPRA6	Description
0	IRQ_1 interrupt requests have priority level 0 (low priority) (Initial value)
1	IRQ_1 interrupt requests have priority level 1 (high priority)

Bit 5—Priority Level A5 (IPRA5): Selects the priority level of IRQ_2 and IRQ_3 interrupt requests.

Bit 5: IPRA5	Description
0	IRQ_2 and IRQ_3 interrupt requests have priority level 0 (low priority) (Initial value)
1	IRQ_2 and IRQ_3 interrupt requests have priority level 1 (high priority)

Bit 4—Priority Level A4 (IPRA4): Selects the priority level of IRQ_4 and IRQ_5 interrupt requests.

Bit 4: IPRA4	Description
0	IRQ_4 and IRQ_5 interrupt requests have priority level 0 (low priority) (Initial value)
1	IRQ_4 and IRQ_5 interrupt requests have priority level 1 (high priority)

Bit 3—Priority Level A3 (IPRA3): Selects the priority level of WDT and refresh controller interrupt requests.

Bit 3: IPRA3	Description
0	WDT and refresh controller interrupt requests have priority level 0 (low priority) (Initial value)
1	WDT and refresh controller interrupt requests have priority level 1 (high priority)

Bit 2—Priority Level A2 (IPRA2): Selects the priority level of ITU channel 0 interrupt requests.

Bit 2: IPRA2	Description
0	ITU channel 0 interrupt requests have priority level 0 (low priority) (Initial value)
1	ITU channel 0 interrupt requests have priority level 1 (high priority)

Bit 1—Priority Level A1 (IPRA1): Selects the priority level of ITU channel 1 interrupt requests.

Bit 1: IPRA1	Description
0	ITU channel 1 interrupt requests have priority level 0 (low priority) (Initial value)
1	ITU channel 1 interrupt requests have priority level 1 (high priority)

Bit 0—Priority Level A0 (IPRA0): Selects the priority level of ITU channel 2 interrupt requests.

Bit 0: IPRA0	Description
0	ITU channel 2 interrupt requests have priority level 0 (low priority) (Initial value)
1	ITU channel 2 interrupt requests have priority level 1 (high priority)

Interrupt Priority Register B (IPRB)

IPRB is an 8-bit readable/writable register in which interrupt priority levels can be set.

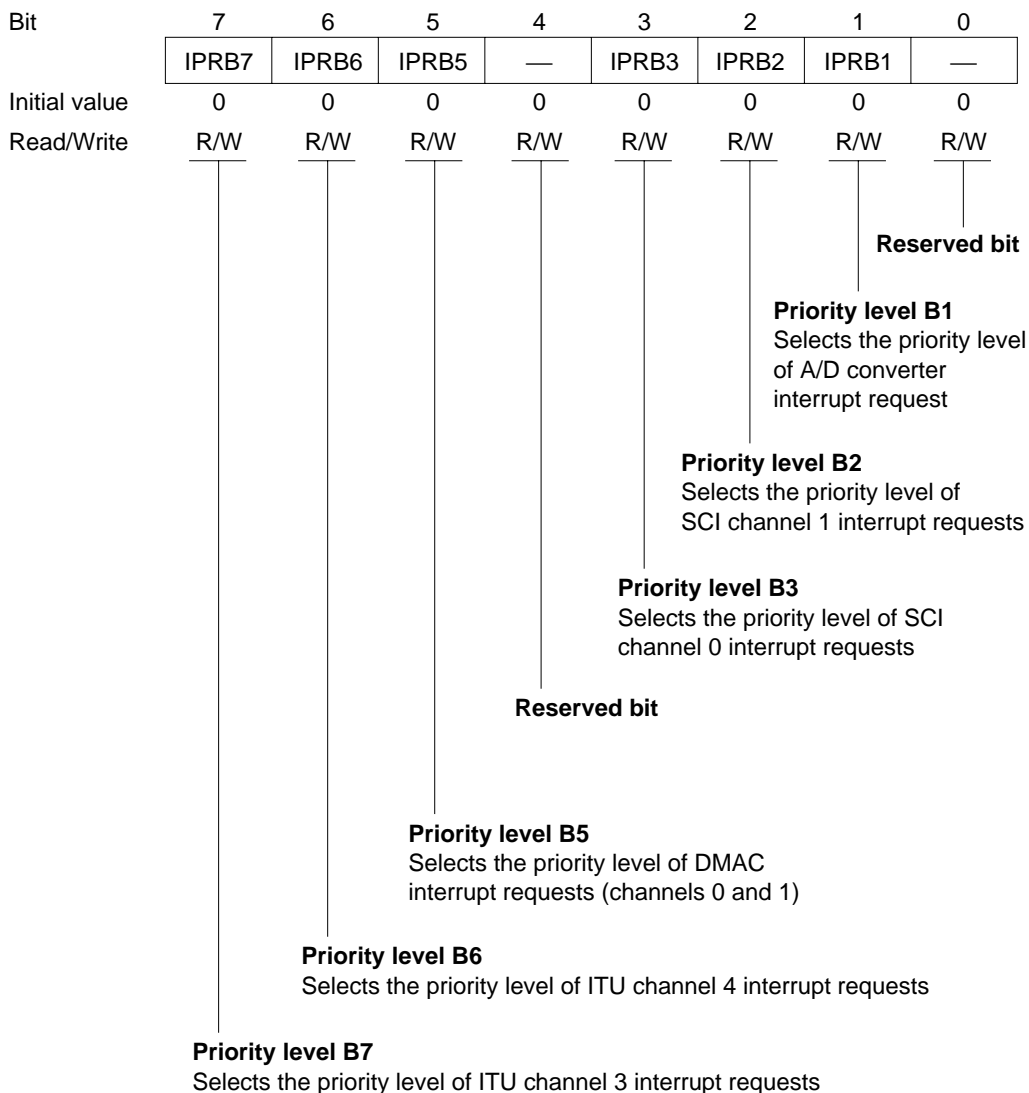

IPRB is initialized to H'00 by a reset and in hardware standby mode.

Bit 7—Priority Level B7 (IPRB7): Selects the priority level of ITU channel 3 interrupt requests.

Bit 7: IPRB7	Description
0	ITU channel 3 interrupt requests have priority level 0 (low priority) (Initial value)
1	ITU channel 3 interrupt requests have priority level 1 (high priority)

Bit 6—Priority Level B6 (IPRB6): Selects the priority level of ITU channel 4 interrupt requests.

Bit 6: IPRB6	Description
0	ITU channel 4 interrupt requests have priority level 0 (low priority) (Initial value)
1	ITU channel 4 interrupt requests have priority level 1 (high priority)

Bit 5—Priority Level B5 (IPRB5): Selects the priority level of DMAC interrupt requests (channels 0 and 1).

Bit 5: IPRB5	Description
0	DMAC interrupt requests (channels 0 and 1) have priority level 0 (low priority) (Initial value)
1	DMAC interrupt requests (channels 0 and 1) have priority level 1 (high priority)

Bit 4—Reserved: This bit can be written and read, but it does not affect interrupt priority.

Bit 3—Priority Level B3 (IPRB3): Selects the priority level of SCI channel 0 interrupt requests.

Bit 3: IPRB3	Description
0	SCI0 interrupt requests have priority level 0 (low priority) (Initial value)
1	SCI0 interrupt requests have priority level 1 (high priority)

Bit 2—Priority Level B2 (IPRB2): Selects the priority level of SCI channel 1 interrupt requests.

Bit 2: IPRB2	Description
0	SCI1 interrupt requests have priority level 0 (low priority) (Initial value)
1	SCI1 interrupt requests have priority level 1 (high priority)

Bit 1—Priority Level B1 (IPRB1): Selects the priority level of A/D converter interrupt requests.

Bit 1: IPRB1	Description
0	A/D converter interrupt requests have priority level 0 (low priority) (Initial value)
1	A/D converter interrupt requests have priority level 1 (high priority)

Bit 0—Reserved: This bit can be written and read, but it does not affect interrupt priority.

5.2.3 IRQ Status Register (ISR)

ISR is an 8-bit readable/writable register that indicates the status of IRQ₀ to IRQ₅ interrupt requests.

Bit	7	6	5	4	3	2	1	0
	—	—	IRQ5F	IRQ4F	IRQ3F	IRQ2F	IRQ1F	IRQ0F
Initial value	0	0	0	0	0	0	0	0
Read/Write	—	—	R/(W)*	R/(W)*	R/(W)*	R/(W)*	R/(W)*	R/(W)*

Reserved bits
IRQ₅ to IRQ₀ flags
These bits indicate IRQ₅ to IRQ₀ interrupt request status

Note: * Only 0 can be written, to clear flags.

ISR is initialized to H'00 by a reset and in hardware standby mode.

Bits 7 and 6—Reserved: Read-only bits, always read as 0.

Bits 5 to 0—IRQ₅ to IRQ₀ Flags (IRQ5F to IRQ0F): These bits indicate the status of IRQ₅ to IRQ₀ interrupt requests.

Bits 5 to 0:

IRQ5F to IRQ0F	Description
0	[Clearing conditions] (Initial value) 0 is written in IRQnF after reading the IRQnF flag when IRQnF = 1. IRQnSC = 0, $\overline{\text{IRQn}}$ input is high, and interrupt exception handling is carried out. IRQnSC = 1 and IRQn interrupt exception handling is carried out.
1	[Setting conditions] IRQnSC = 0 and $\overline{\text{IRQn}}$ input is low. IRQnSC = 1 and $\overline{\text{IRQn}}$ input changes from high to low.

Note: n = 5 to 0

5.2.4 IRQ Enable Register (IER)

IER is an 8-bit readable/writable register that enables or disables IRQ₀ to IRQ₅ interrupt requests.

Bit	7	6	5	4	3	2	1	0
	—	—	IRQ5E	IRQ4E	IRQ3E	IRQ2E	IRQ1E	IRQ0E
Initial value	0	0	0	0	0	0	0	0
Read/Write	R/W	R/W	R/W	R/W	R/W	R/W	R/W	R/W

Reserved bits
IRQ₅ to IRQ₀ enable
 These bits enable or disable IRQ₅ to IRQ₀ interrupts

IER is initialized to H'00 by a reset and in hardware standby mode.

Bits 7 and 6—Reserved: These bits can be written and read, but they do not enable or disable interrupts.

Bits 5 to 0—IRQ₅ to IRQ₀ Enable (IRQ5E to IRQ0E): These bits enable or disable IRQ₅ to IRQ₀ interrupts.

Bits 5 to 0:

IRQ5E to IRQ0E	Description
0	IRQ ₅ to IRQ ₀ interrupts are disabled (Initial value)
1	IRQ ₅ to IRQ ₀ interrupts are enabled

5.2.5 IRQ Sense Control Register (ISCR)

ISCR is an 8-bit readable/writable register that selects level sensing or falling-edge sensing of the inputs at pins $\overline{\text{IRQ}}_5$ to $\overline{\text{IRQ}}_0$.

Bit	7	6	5	4	3	2	1	0
	—	—	IRQ5SC	IRQ4SC	IRQ3SC	IRQ2SC	IRQ1SC	IRQ0SC
Initial value	0	0	0	0	0	0	0	0
Read/Write	R/W	R/W	R/W	R/W	R/W	R/W	R/W	R/W

Reserved bits

IRQ₅ to IRQ₀ sense control

These bits select level sensing or falling-edge sensing for IRQ₅ to IRQ₀ interrupts

ISCR is initialized to H'00 by a reset and in hardware standby mode.

Bits 7 and 6—Reserved: These bits can be written and read, but they do not select level or falling-edge sensing.

Bits 5 to 0—IRQ₅ to IRQ₀ Sense Control (IRQ5SC to IRQ0SC): These bits select whether interrupts IRQ₅ to IRQ₀ are requested by level sensing of pins $\overline{\text{IRQ}}_5$ to $\overline{\text{IRQ}}_0$, or by falling-edge sensing.

Bits 5 to 0: **Description**
IRQ5SC to IRQ0SC

0	Interrupts are requested when $\overline{\text{IRQ}}_5$ to $\overline{\text{IRQ}}_0$ inputs are low (Initial value)
1	Interrupts are requested by falling-edge input at $\overline{\text{IRQ}}_5$ to $\overline{\text{IRQ}}_0$

5.3 Interrupt Sources

The interrupt sources include external interrupts (NMI, IRQ₀ to IRQ₃) and 30 internal interrupts.

5.3.1 External Interrupts

There are seven external interrupts: NMI, and IRQ₀ to IRQ₅. Of these, NMI, IRQ₀, IRQ₁, and IRQ₂ can be used to exit software standby mode.

NMI

NMI is the highest-priority interrupt and is always accepted, regardless of the states of the I and UI bits in CCR. The NMIEG bit in SYSCR selects whether an interrupt is requested by the rising or falling edge of the input at the NMI pin*. NMI interrupt exception handling has vector number 7.

Note: * For the H8/3048F-ONE (single power supply with flash memory), the NMI input may be prohibited. For details, refer to section 18.8.4, NMI Input Disable Conditions.

IRQ₀ to IRQ₅ Interrupts

These interrupts are requested by input signals at pins $\overline{\text{IRQ}}_0$ to $\overline{\text{IRQ}}_5$. The IRQ₀ to IRQ₅ interrupts have the following features.

- ISCR settings can select whether an interrupt is requested by the low level of the input at pins $\overline{\text{IRQ}}_0$ to $\overline{\text{IRQ}}_5$, or by the falling edge.
- IER settings can enable or disable the IRQ₀ to IRQ₅ interrupts. Interrupt priority levels can be assigned by four bits in IPRA (IPRA7 to IPRA4).
- The status of IRQ₀ to IRQ₅ interrupt requests is indicated in ISR. The ISR flags can be cleared to 0 by software.

Figure 5.2 shows a block diagram of interrupts IRQ₀ to IRQ₅.

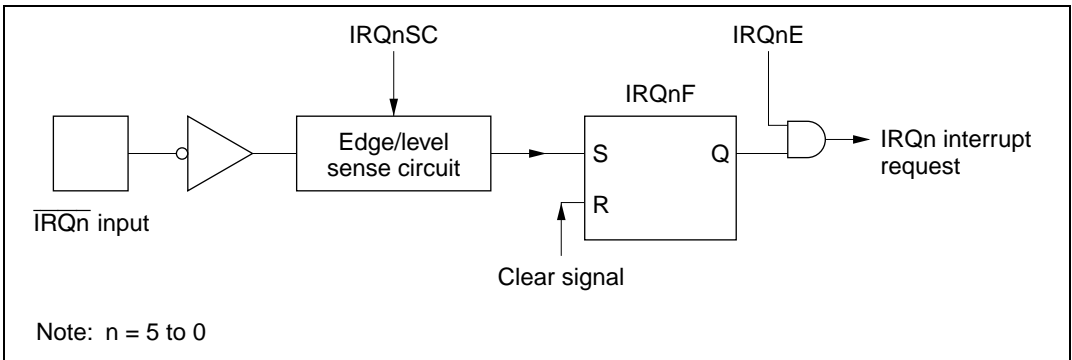

Figure 5.2 Block Diagram of Interrupts IRQ_0 to IRQ_5

Figure 5.3 shows the timing of the setting of the interrupt flags (IRQnF).

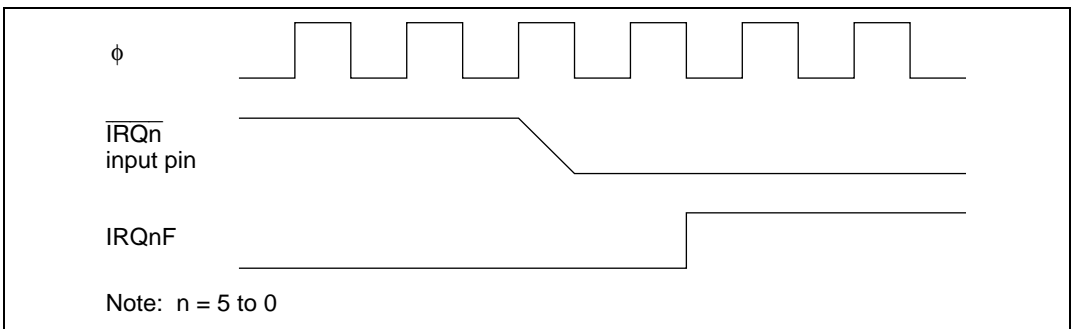

Figure 5.3 Timing of Setting of IRQnF

Interrupts IRQ_0 to IRQ_5 have vector numbers 12 to 17. These interrupts are detected regardless of whether the corresponding pin is set for input or output. When using a pin for external interrupt input, clear its DDR bit to 0 and do not use the pin for chip select output, refresh output, or SCI input or output.

5.3.2 Internal Interrupts

Thirty internal interrupts are requested from the on-chip supporting modules.

- Each on-chip supporting module has status flags for indicating interrupt status, and enable bits for enabling or disabling interrupts.
- Interrupt priority levels can be assigned in IPRA and IPRB.
- ITU and SCI interrupt requests can activate the DMAC, in which case no interrupt request is sent to the interrupt controller, and the I and UI bits are disregarded.

5.3.3 Interrupt Vector Table

Table 5.3 lists the interrupt sources, their vector addresses, and their default priority order. In the default priority order, smaller vector numbers have higher priority. The priority of interrupts other than NMI can be changed in IPRA and IPRB. The priority order after a reset is the default order shown in table 5.3.

Table 5.3 Interrupt Sources, Vector Addresses, and Priority

Interrupt Source	Origin	Vector Number	Vector Address*	IPR	Priority
NMI	External pins	7	H'001C to H'001F	—	High ↑
IRQ ₀		12	H'0030 to H'0033	IPRA7	
IRQ ₁		13	H'0034 to H'0037	IPRA6	
IRQ ₂		14	H'0038 to H'003B	IPRA5	
IRQ ₃		15	H'003C to H'003F		
IRQ ₄		16	H'0040 to H'0043	IPRA4	
IRQ ₅		17	H'0044 to H'0047		
Reserved	—	18	H'0048 to H'004B		
		19	H'004C to H'004F		
WOVI (interval timer)	Watchdog timer	20	H'0050 to H'0053	IPRA3	
CMI (compare match)	Refresh controller	21	H'0054 to H'0057		
Reserved	—	22	H'0058 to H'005B		
		23	H'005C to H'005F		
IMIA0 (compare match/ input capture A0)	ITU channel 0	24	H'0060 to H'0063	IPRA2	
IMIB0 (compare match/ input capture B0)		25	H'0064 to H'0067		
OVI0 (overflow 0)		26	H'0068 to H'006B		
Reserved		—	27	H'006C to H'006F	
IMIA1 (compare match/ input capture A1)	ITU channel 1	28	H'0070 to H'0073	IPRA1	
IMIB1 (compare match/ input capture B1)		29	H'0074 to H'0077		
OVI1 (overflow 1)		30	H'0078 to H'007B		
Reserved	—	31	H'007C to H'007F		Low

Interrupt Source	Origin	Vector Number	Vector Address*	IPR	Priority
ERI0 (receive error 0)	SCI channel 0	52	H'00D0 to H'00D3	IPRB3	High ↑ Low
RXI0 (receive data full 0)		53	H'00D4 to H'00D7		
TXI0 (transmit data empty 0)		54	H'00D8 to H'00DB		
TEI0 (transmit end 0)		55	H'00DC to H'00DF		
ERI1 (receive error 1)	SCI channel 1	56	H'00E0 to H'00E3	IPRB2	
RXI1 (receive data full 1)		57	H'00E4 to H'00E7		
TXI1 (transmit data empty 1)		58	H'00E8 to H'00EB		
TEI1 (transmit end 1)		59	H'00EC to H'00EF		
ADI (A/D end)	A/D	60	H'00F0 to H'00F3	IPRB1	Low

Note: * Lower 16 bits of the address.

5.4 Interrupt Operation

5.4.1 Interrupt Handling Process

The H8/3048B Group handles interrupts differently depending on the setting of the UE bit. When UE = 1, interrupts are controlled by the I bit. When UE = 0, interrupts are controlled by the I and UI bits. Table 5.4 indicates how interrupts are handled for all setting combinations of the UE, I, and UI bits.

NMI interrupts are always accepted except in the reset and hardware standby states*. IRQ interrupts and interrupts from the on-chip supporting modules have their own enable bits. Interrupt requests are ignored when the enable bits are cleared to 0.

Note: * For the H8/3048F-ONE (single power supply with flash memory), the NMI input may be prohibited. For details, refer to section 18.8.4, NMI Input Disable Conditions.

Table 5.4 UE, I, and UI Bit Settings and Interrupt Handling

SYSCR	CCR		Description
	I	UI	
1	0	—	All interrupts are accepted. Interrupts with priority level 1 have higher priority.
	1	—	No interrupts are accepted except NMI.
0	0	—	All interrupts are accepted. Interrupts with priority level 1 have higher priority.
	1	0	NMI and interrupts with priority level 1 are accepted.
		1	No interrupts are accepted except NMI.

UE = 1

Interrupts IRQ₀ to IRQ₅ and interrupts from the on-chip supporting modules can all be masked by the I bit in the CPU's CCR. Interrupts are masked when the I bit is set to 1, and unmasked when the I bit is cleared to 0. Interrupts with priority level 1 have higher priority. Figure 5.4 is a flowchart showing how interrupts are accepted when UE = 1.

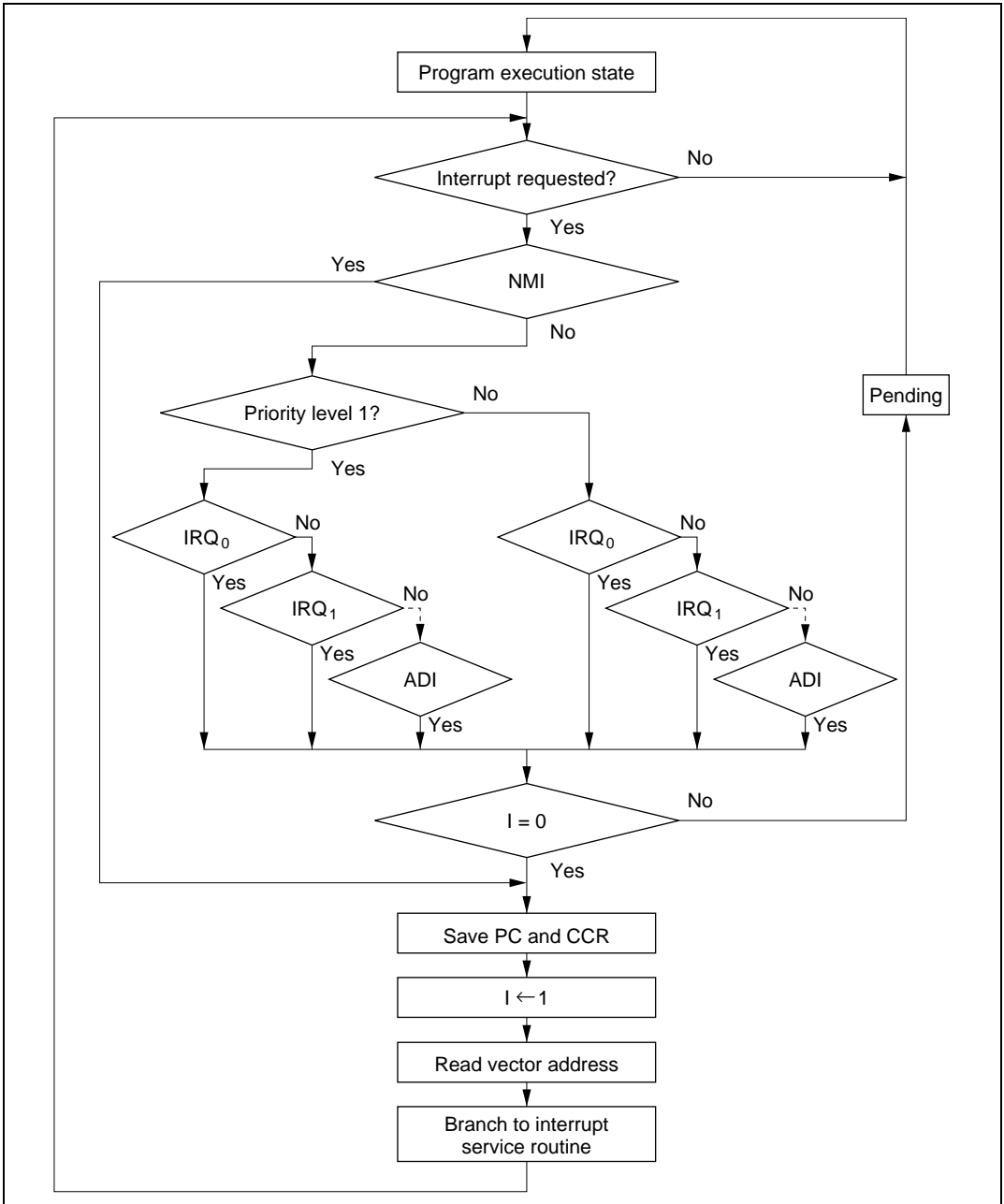

Figure 5.4 Process Up to Interrupt Acceptance when UE = 1

- If an interrupt condition occurs and the corresponding interrupt enable bit is set to 1, an interrupt request is sent to the interrupt controller.
- When the interrupt controller receives one or more interrupt requests, it selects the highest-priority request, following the IPR interrupt priority settings, and holds other requests pending. If two or more interrupts with the same IPR setting are requested simultaneously, the interrupt controller follows the priority order shown in table 5.3.
- The interrupt controller checks the I bit. If the I bit is cleared to 0, the selected interrupt request is accepted. If the I bit is set to 1, only NMI is accepted; other interrupt requests are held pending.
- When an interrupt request is accepted, interrupt exception handling starts after execution of the current instruction has been completed.
- In interrupt exception handling, PC and CCR are saved to the stack area. The PC value that is saved indicates the address of the first instruction that will be executed after the return from the interrupt service routine.
- Next the I bit is set to 1 in CCR, masking all interrupts except NMI.
- The vector address of the accepted interrupt is generated, and the interrupt service routine starts executing from the address indicated by the contents of the vector address.

UE = 0

The I and UI bits in the CPU's CCR and the IPR bits enable three-level masking of IRQ₀ to IRQ₅ interrupts and interrupts from the on-chip supporting modules.

- Interrupt requests with priority level 0 are masked when the I bit is set to 1, and are unmasked when the I bit is cleared to 0.
- Interrupt requests with priority level 1 are masked when the I and UI bits are both set to 1, and are unmasked when either the I bit or the UI bit is cleared to 0.

For example, if the interrupt enable bits of all interrupt requests are set to 1, IPRA is set to H'20, and IPRB is set to H'00 (giving IRQ₂ and IRQ₃ interrupt requests priority over other interrupts), interrupts are masked as follows:

- If I = 0, all interrupts are unmasked (priority order: NMI > IRQ₂ > IRQ₃ > IRQ₀ ...).
- If I = 1 and UI = 0, only NMI, IRQ₂, and IRQ₃ are unmasked.
- If I = 1 and UI = 1, all interrupts are masked except NMI.

Figure 5.5 shows the transitions among the above states.

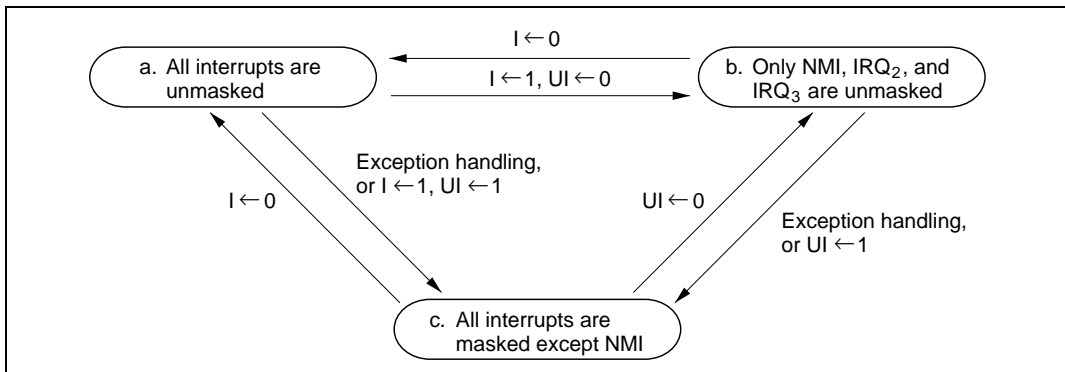

Figure 5.5 Interrupt Masking State Transitions (Example)

Figure 5.6 is a flowchart showing how interrupts are accepted when $UE = 0$.

- If an interrupt condition occurs and the corresponding interrupt enable bit is set to 1, an interrupt request is sent to the interrupt controller.
- When the interrupt controller receives one or more interrupt requests, it selects the highest-priority request, following the IPR interrupt priority settings, and holds other requests pending. If two or more interrupts with the same IPR setting are requested simultaneously, the interrupt controller follows the priority order shown in table 5.3.
- The interrupt controller checks the I bit. If the I bit is cleared to 0, the selected interrupt request is accepted regardless of its IPR setting, and regardless of the UI bit. If the I bit is set to 1 and the UI bit is cleared to 0, only NMI and interrupts with priority level 1 are accepted; interrupt requests with priority level 0 are held pending. If the I bit and UI bit are both set to 1, only NMI is accepted; all other interrupt requests are held pending.
- When an interrupt request is accepted, interrupt exception handling starts after execution of the current instruction has been completed.
- In interrupt exception handling, PC and CCR are saved to the stack area. The PC value that is saved indicates the address of the first instruction that will be executed after the return from the interrupt service routine.
- The I and UI bits are set to 1 in CCR, masking all interrupts except NMI.
- The vector address of the accepted interrupt is generated, and the interrupt service routine starts executing from the address indicated by the contents of the vector address.

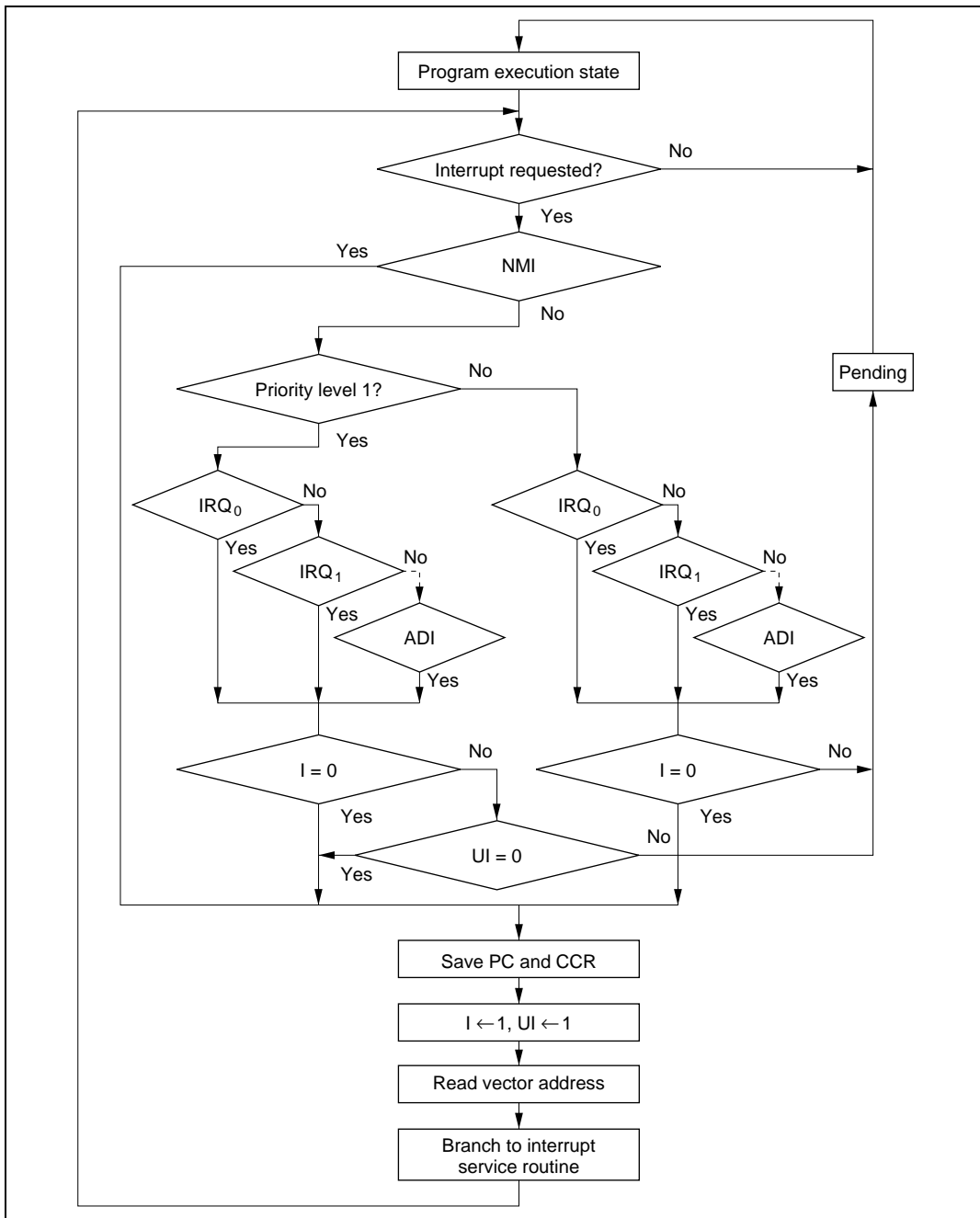

Figure 5.6 Process Up to Interrupt Acceptance when UE = 0

5.4.2 Interrupt Sequence

Figure 5.7 shows the interrupt sequence in mode 2 when the program code and stack are in an external memory area accessed in two states via a 16-bit bus.

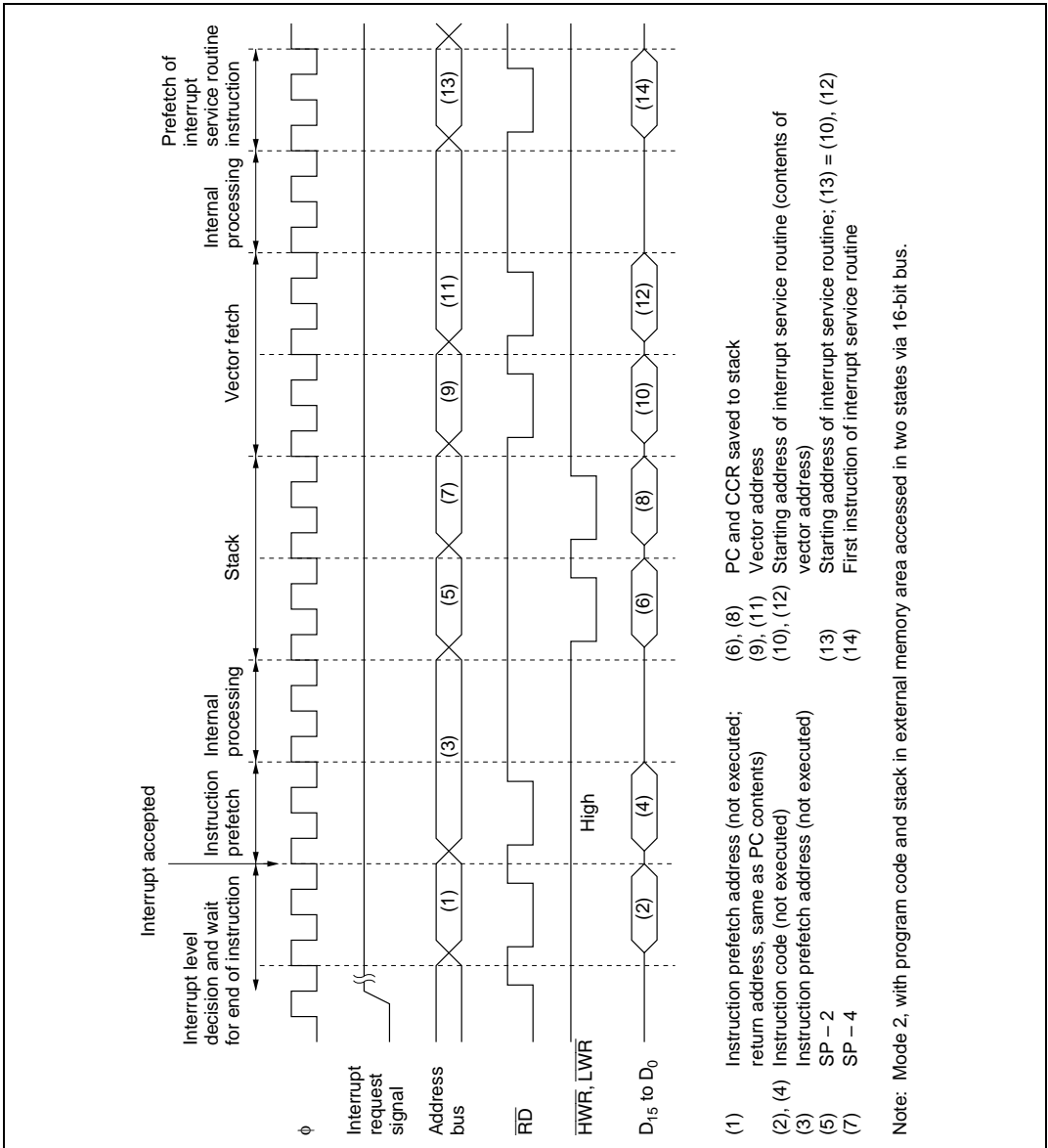

Figure 5.7 Interrupt Sequence (Mode 2, Two-State Access, Stack in External Memory)

5.4.3 Interrupt Response Time

Table 5.5 indicates the interrupt response time from the occurrence of an interrupt request until the first instruction of the interrupt service routine is executed.

Table 5.5 Interrupt Response Time

No.	Item	On-Chip Memory	External Memory			
			8-Bit Bus		16-Bit Bus	
			2 States	3 States	2 States	3 States
1	Interrupt priority decision	2 ^{*1}	2 ^{*1}	2 ^{*1}	2 ^{*1}	2 ^{*1}
2	Maximum number of states until end of current instruction	1 to 23 ^{*5}	1 to 27 ^{*5 *6}	1 to 41 ^{*6}	1 to 23 ^{*5}	1 to 25 ^{*5}
3	Saving PC and CCR to stack	4	8	12 ^{*4}	4	6 ^{*4}
4	Vector fetch	4	8	12 ^{*4}	4	6 ^{*4}
5	Instruction prefetch ^{*2}	4	8	12 ^{*4}	4	6 ^{*4}
6	Internal processing ^{*3}	4	4	4	4	4
Total		19 to 41	31 to 57	43 to 83	19 to 41	25 to 49

- Notes:
- 1 state for internal interrupts.
 - Prefetch after the interrupt is accepted and prefetch of the first instruction in the interrupt service routine.
 - Internal processing after the interrupt is accepted and internal processing after prefetch.
 - The number of states increases if wait states are inserted in external memory access.
 - Example for DIVXS.W Rs,ERd and MULXS.W Rs,ERd
 - Example for MOV.L @(d:24,ERs),ERd and MOV.L ERs,@(d:24,ERd)

5.5 Usage Notes

5.5.1 Contention between Interrupt and Interrupt-Disabling Instruction

When an instruction clears an interrupt enable bit to 0 to disable the interrupt, the interrupt is not disabled until after execution of the instruction is completed. If an interrupt occurs while a BCLR, MOV, or other instruction is being executed to clear its interrupt enable bit to 0, at the instant when execution of the instruction ends the interrupt is still enabled, so its interrupt exception handling is carried out. If a higher-priority interrupt is also requested, however, interrupt exception handling for the higher-priority interrupt is carried out, and the lower-priority interrupt is ignored. This also applies to the clearing of an interrupt flag.

Figure 5.8 shows an example in which an IMIEA bit is cleared to 0 in TIER of the ITU.

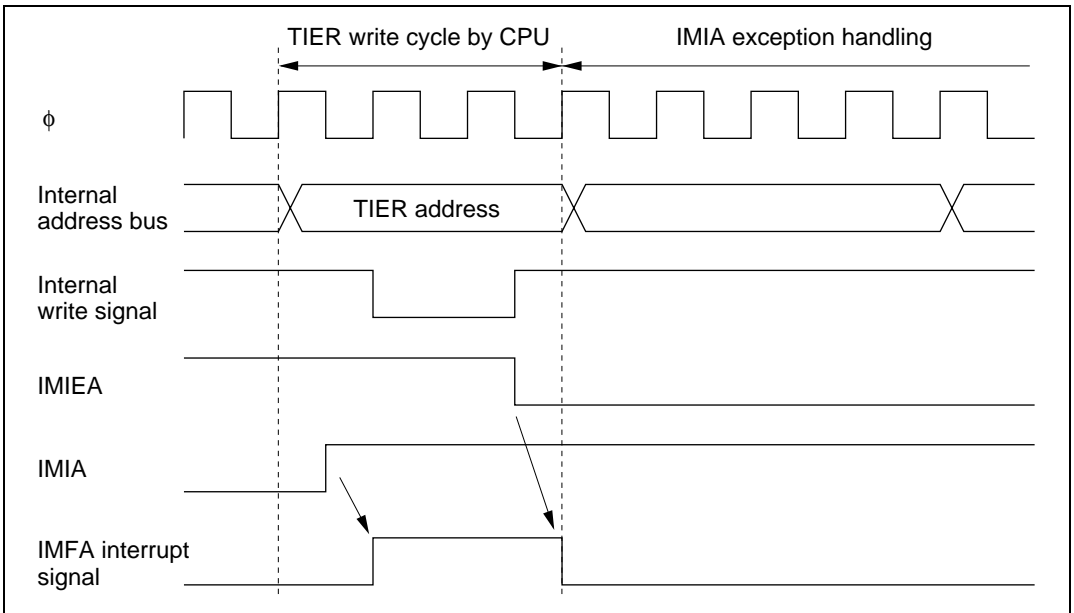

Figure 5.8 Contention between Interrupt and Interrupt-Disabling Instruction

This type of contention will not occur if the interrupt is masked when the interrupt enable bit or flag is cleared to 0.

5.5.2 Instructions That Inhibit Interrupts

The LDC, ANDC, ORC, and XORC instructions inhibit interrupts. When an interrupt occurs, after determining the interrupt priority, the interrupt controller requests a CPU interrupt. If the CPU is currently executing one of these interrupt-inhibiting instructions, however, when the instruction is completed the CPU always continues by executing the next instruction.

5.5.3 Interrupts during EEPMOV Instruction Execution

The EEPMOV.B and EEPMOV.W instructions differ in their reaction to interrupt requests.

When the EEPMOV.B instruction is executing a transfer, no interrupts are accepted until the transfer is completed, not even NMI.

When the EEPMOV.W instruction is executing a transfer, interrupt requests other than NMI are not accepted until the transfer is completed. If NMI is requested, NMI exception handling starts at a transfer cycle boundary. The PC value saved on the stack is the address of the next instruction. Programs should be coded as follows to allow for NMI interrupts during EEPMOV.W execution:

```
L1: EEPMOV.W  
    MOV.W R4, R4  
    BNE L1
```

5.5.4 Usage Notes on External Interrupts

The IRQnF flag specification calls for the flag to be cleared by writing 0 to it after it has been read while set to 1. However, it is possible for the IRQnF flag to be cleared by mistake simply by writing 0 to it, irrespective of whether it has been read while set to 1, with the result that interrupt exception handling is not executed. This occurs when the following conditions are fulfilled.

- Setting conditions
 1. Multiple external interrupts (IRQa, IRQb) are being used.
 2. Different clearing methods are being used: clearing by writing 0 for the IRQaF flag, and clearing by hardware for the IRQbF flag.
 3. A bit manipulation instruction is used on the IRQ status register to clear the IRQaF flag, or else ISR is read as a byte unit, the IRQaF flag bit is cleared, and the values read in the other bits are written as a byte unit.

- Occurrence conditions
 1. When $IRQaF = 1$, for the $IRQaF$ flag to clear, ISR register read is executed. Thereafter interrupt processing is carried out and $IRQbF$ flag clears.
 2. $IRQaF$ flag clear and $IRQbF$ flag generation compete ($IRQaF$ flag setting).
(The ISR read needed for $IRQaF$ flag clear was at $IRQbF = 0$ but in the time taken for ISR write, $IRQbF = 1$ was reached.)

In all of the setting conditions 1 to 3 and occurrence conditions 1 and 2 are generated, $IRQbF$ clears in error during ISR write for occurrence condition 2 and interrupt processing is not carried out. However, if $IRQbF$ flag reaches 0 between occurrence conditions 1 and 2, $IRQbF$ flag does not clear in error.

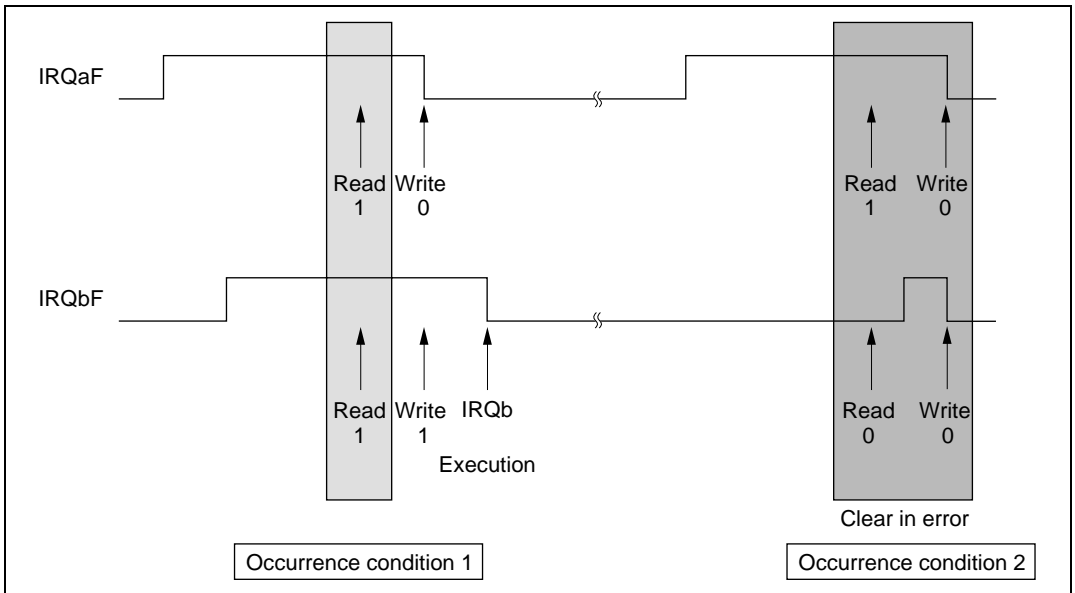

Figure 5.9 $IRQnF$ Flag When Interrupt Processing Is Not Conducted

In this situation, conduct one of the following countermeasures.

Countermeasure 1: When clears IRQaF flag, do not use the bit manipulation instruction, read the ISR in bytes. Then write a value in bytes which sets IRQaF flag to 0 and other bits to 1.

For example, if a = 0

```
MOV.B @ISR,R0L
MOV.B #HFE,R0L
MOV.B R0L,@ISR
```

Countermeasure 2: During IRQb interrupt exception processing, carry out IRQbF flag clear dummy processing.

For example, if b = 1

```
IRQB MOV.B #HFD,R0L
      MOV.B R0L,@ISR
      ⋮
```

5.5.5 Notes on Non-Maskable Interrupts (NMI)

NMI is an exception processing that can be executed by the interrupt controller and CPU when the chip internal circuits are operating normally under a specified electrical characteristics. If an NMI is executed when the circuits are not operating normally due to some factors such as software or abnormal interrupt of input to the pins (runaway execution), the operation will not be guaranteed.

Incorrect NMI Operation Factors: Software

1. When an interrupt exception processing is executed in an H8/300H CPU, it is assumed that the stack pointer (SP(ER7)) has already been set by software, and that the stack pointer (SP(ER7)) points to the stack area set in a system such as RAM. If the program is in a runaway execution, the stack pointer may be overflowed and updated illegally. Therefore, normal operation will not be guaranteed.
2. Requests for NMIs can be accepted on the rising or falling edge of a pin. Acceptance of the rising or falling edge depends on the setting of the bit NMIEG in the system control register (SYSCR). It is necessary for the customer to set the bit according to the designated system. When the program is in a runaway execution, this bit may be rewritten illegally. Therefore, the system may not operate as expected.

3. This chip has a break function to implement on-board emulation for specific customers. To use this break function, execute the BRK instruction (H'5770). Note that the BRK instruction is usually undefined. Therefore, if the CPU accidentally executes the instruction, the chip will perform exceptional processing and will enter the break mode. In the break mode, interrupts including the NMI are inhibited and the count of the watch dog timer will be stopped. Then by executing the RTB (H'56F0) instruction, the break mode will be cancelled, and usual program execution will resume. When the execution is reset during break mode, the CPU enters the reset state and the break mode is cancelled. Once the reset has been cancelled, normal program execution will resume after the reset exception processing has been executed.

Incorrect NMI Operation Factors: Abnormal Interrupts Input to the Chip Pins

If an abnormal interrupt which was not specified in the electrical characteristics is input to a pin during a chip operation, the chip may be destroyed. In this case, the operation of the chip will not be guaranteed.

When an abnormal interrupt has been input to a pin, the chip may not be destroyed; however, the internal circuits of the chip may partially or wholly malfunction, and the CPU may enter an unimagined undefined state when the CPU was designed. If this occurs, it will be impossible to control the operation of the chip by external pins other than the external reset and standby pins, and the operation of the NMI will not be guaranteed. In this case, after some specified signals have been input to the pins, input an external reset so that the chip can enter the normal program execution state again.

Section 6 Bus Controller

6.1 Overview

The H8/3048B Group has an on-chip bus controller that divides the address space into eight areas and can assign different bus specifications to each. This enables different types of memory to be connected easily.

A bus arbitration function of the bus controller controls the operation of the DMA controller (DMAC) and refresh controller. The bus controller can also release the bus to an external device.

6.1.1 Features

Features of the bus controller are listed below.

- Independent settings for address areas 7 to 0
 - 128-kbyte areas in 1-Mbyte modes; 2-Mbyte areas in 16-Mbyte modes.
 - Chip select signals (\overline{CS}_7 to \overline{CS}_0) can be output for areas 7 to 0.
 - Areas can be designated for 8-bit or 16-bit access.
 - Areas can be designated for two-state or three-state access.
- Four wait modes
 - Programmable wait mode, pin auto-wait mode, and pin wait modes 0 and 1 can be selected.
 - Zero to three wait states can be inserted automatically.
- Bus arbitration function
 - A built-in bus arbiter arbitrates the bus right to the CPU, DMAC, refresh controller, or an external bus master.

6.1.2 Block Diagram

Figure 6.1 shows a block diagram of the bus controller.

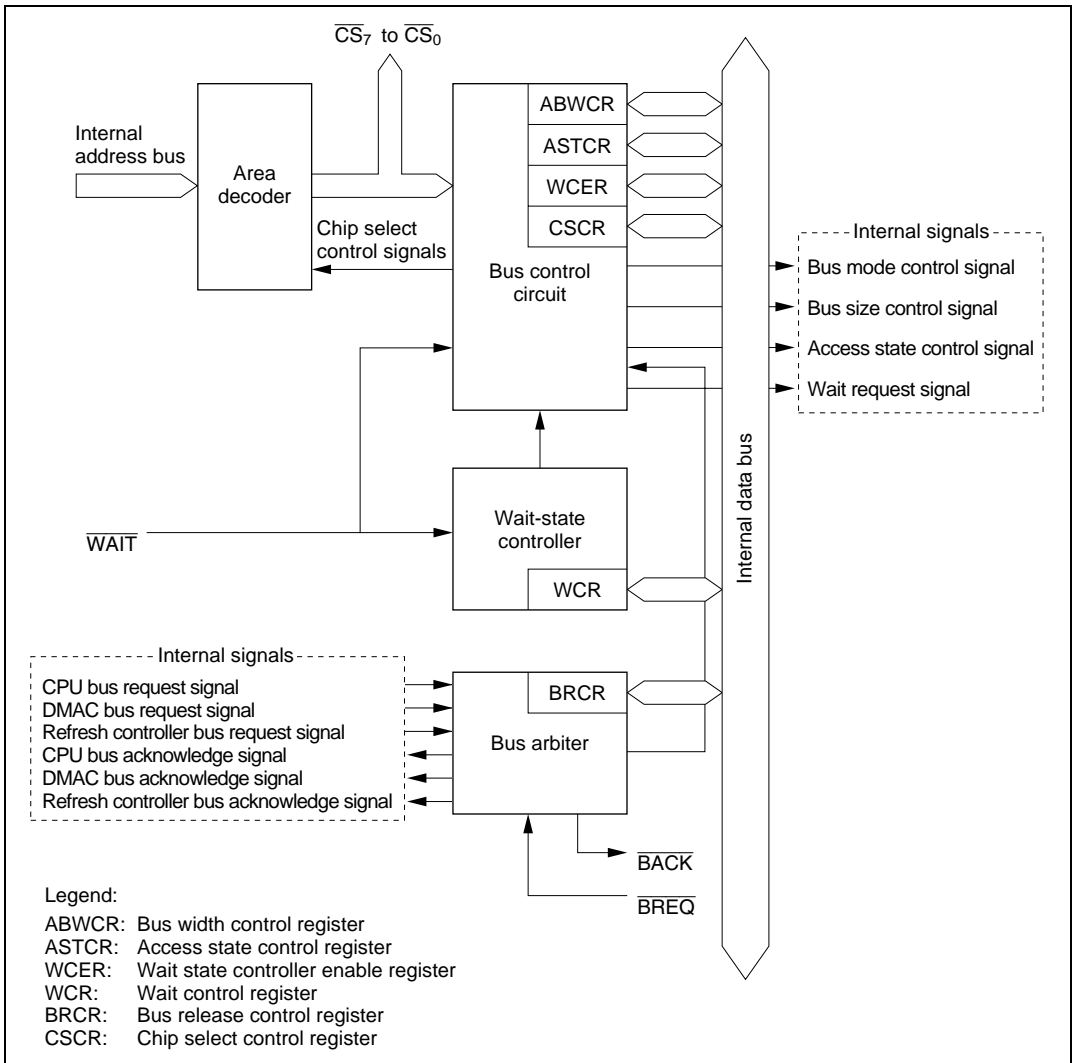

Figure 6.1 Block Diagram of Bus Controller

6.1.3 Input/Output Pins

Table 6.1 summarizes the bus controller's input/output pins.

Table 6.1 Bus Controller Pins

Name	Abbreviation	I/O	Function
Chip select 7 to 0	\overline{CS}_7 to \overline{CS}_0	Output	Strobe signals selecting areas 7 to 0
Address strobe	\overline{AS}	Output	Strobe signal indicating valid address output on the address bus
Read	\overline{RD}	Output	Strobe signal indicating reading from the external address space
High write	\overline{HWR}	Output	Strobe signal indicating writing to the external address space, with valid data on the upper data bus (D_{15} to D_8)
Low write	\overline{LWR}	Output	Strobe signal indicating writing to the external address space, with valid data on the lower data bus (D_7 to D_0)
Wait	\overline{WAIT}	Input	Wait request signal for access to external three-state-access areas
Bus request	\overline{BREQ}	Input	Request signal for releasing the bus to an external device
Bus acknowledge	\overline{BACK}	Output	Acknowledge signal indicating the bus is released to an external device

6.1.4 Register Configuration

Table 6.2 summarizes the bus controller's registers.

Table 6.2 Bus Controller Registers

Address*	Name	Abbreviation	R/W	Initial Value	
				Modes 1, 3, 5, 6	Modes 2, 4, 7
H'FFEC	Bus width control register	ABWCR	R/W	H'FF	H'00
H'FFED	Access state control register	ASTCR	R/W	H'FF	H'FF
H'FFEE	Wait control register	WCR	R/W	H'F3	H'F3
H'FFEF	Wait state controller enable register	WCER	R/W	H'FF	H'FF
H'FFF3	Bus release control register	BRCR	R/W	H'FE	H'FE
H'FF5F	Chip select control register	CSCR	R/W	H'0F	H'0F

Note: * Lower 16 bits of the address.

6.2 Register Descriptions

6.2.1 Bus Width Control Register (ABWCR)

ABWCR is an 8-bit readable/writable register that selects 8-bit or 16-bit access for each area.

Bit	7	6	5	4	3	2	1	0
	ABW7	ABW6	ABW5	ABW4	ABW3	ABW2	ABW1	ABW0
Initial value	Modes 1, 3, 5, 6	1	1	1	1	1	1	1
	Modes 2, 4, 7	0	0	0	0	0	0	0
Read/Write	R/W	R/W	R/W	R/W	R/W	R/W	R/W	R/W

Bits selecting bus width for each area

When ABWCR contains H'FF (selecting 8-bit access for all areas), the chip operates in 8-bit bus mode: the upper data bus (D_{15} to D_8) is valid, and port 4 is an input/output port. When at least one bit is cleared to 0 in ABWCR, the chip operates in 16-bit bus mode with a 16-bit data bus (D_{15} to D_0). In modes 1, 3, 5, and 6 ABWCR is initialized to H'FF by a reset and in hardware standby mode. In modes 2, 4, and 7 ABWCR is initialized to H'00 by a reset and in hardware standby mode. ABWCR is not initialized in software standby mode.

Bits 7 to 0—Areas 7 to 0 Bus Width Control (ABW7 to ABW0): These bits select 8-bit access or 16-bit access to the corresponding address areas.

Bits 7 to 0:

ABW7 to ABW0	Description
0	Areas 7 to 0 are 16-bit access areas
1	Areas 7 to 0 are 8-bit access areas

ABWCR specifies the bus width of external memory areas. The bus width of on-chip memory and internal I/O registers is fixed and does not depend on ABWCR settings. These settings are therefore meaningless in single-chip mode (mode 7).

6.2.2 Access State Control Register (ASTCR)

ASTCR is an 8-bit readable/writable register that selects whether each area is accessed in two states or three states.

Bit	7	6	5	4	3	2	1	0
	AST7	AST6	AST5	AST4	AST3	AST2	AST1	AST0
Initial value	1	1	1	1	1	1	1	1
Read/Write	R/W	R/W	R/W	R/W	R/W	R/W	R/W	R/W

Bits selecting number of states for access to each area

ASTCR is initialized to H'FF by a reset and in hardware standby mode. It is not initialized in software standby mode.

Bits 7 to 0—Areas 7 to 0 Access State Control (AST7 to AST0): These bits select whether the corresponding area is accessed in two or three states.

Bits 7 to 0:

AST7 to AST0	Description
0	Areas 7 to 0 are accessed in two states
1	Areas 7 to 0 are accessed in three states (Initial value)

ASTCR specifies the number of states in which external areas are accessed. On-chip memory and internal I/O registers are accessed in a fixed number of states that does not depend on ASTCR settings. These settings are therefore meaningless in single-chip mode (mode 7).

6.2.3 Wait Control Register (WCR)

WCR is an 8-bit readable/writable register that selects the wait mode for the wait-state controller (WSC) and specifies the number of wait states.

Bit	7	6	5	4	3	2	1	0
	—	—	—	—	WMS1	WMS0	WC1	WC0
Initial value	1	1	1	1	0	0	1	1
Read/Write	—	—	—	—	R/W	R/W	R/W	R/W

Reserved bits
 These bits are reserved and always read as 1.

Wait mode select 1/0
 These bits select the wait mode.

Wait count 1/0
 These bits select the number of wait states inserted.

WCR is initialized to H'F3 by a reset and in hardware standby mode. It is not initialized in software standby mode.

Bits 7 to 4—Reserved: Read-only bits, always read as 1.

Bits 3 and 2—Wait Mode Select 1 and 0 (WMS1, WMS0): These bits select the wait mode.

Bit 3: WMS1	Bit 2: WMS0	Description
0	0	Programmable wait mode (Initial value)
	1	No wait states inserted by wait-state controller
1	0	Pin wait mode 1
	1	Pin auto-wait mode

Bits 1 and 0—Wait Count 1 and 0 (WC1, WC0): These bits select the number of wait states inserted in access to external three-state-access areas.

Bit 1: WC1	Bit 0: WC0	Description
0	0	No wait states inserted by wait-state controller
	1	1 state inserted
1	0	2 states inserted
	1	3 states inserted (Initial value)

6.2.4 Wait State Controller Enable Register (WCER)

WCER is an 8-bit readable/writable register that enables or disables wait-state control of external three-state-access areas by the wait-state controller.

Bit	7	6	5	4	3	2	1	0
	WCE7	WCE6	WCE5	WCE4	WCE3	WCE2	WCE1	WCE0
Initial value	1	1	1	1	1	1	1	1
Read/Write	R/W	R/W	R/W	R/W	R/W	R/W	R/W	R/W

Wait-state controller enable 7 to 0

These bits enable or disable wait-state control

WCER is initialized to H'FF by a reset and in hardware standby mode. It is not initialized in software standby mode.

Bits 7 to 0—Wait-State Controller Enable 7 to 0 (WCE7 to WCE0): These bits enable or disable wait-state control of external three-state-access areas.

Bits 7 to 0:

WCE7 to WCE0	Description
0	Wait-state control disabled (pin wait mode 0)
1	Wait-state control enabled (Initial value)

Since WCER enables or disables wait-state control of external three-state-access areas, these settings are meaningless in single-chip mode (mode 7).

6.2.5 Bus Release Control Register (BRCR)

BRCR is an 8-bit readable/writable register that enables address output on bus lines A_{23} to A_{21} and enables or disables release of the bus to an external device.

Bit	7	6	5	4	3	2	1	0
	A23E	A22E	A21E	—	—	—	—	BRLE
Initial value	1	1	1	1	1	1	1	0
Read/Write	Modes 1, 2, 5, 7 —	—	—	—	—	—	—	R/W
	Modes 3, 4, 6 R/W	R/W	R/W	—	—	—	—	R/W
	Address 23 to 21 enable These bits enable PA_6 to PA_4 to be used for A_{23} to A_{21} address output			Reserved bits		Bus release enable Enables or disables release of the bus to an external device		

BRCR is initialized to H'FE by a reset and in hardware standby mode. It is not initialized in software standby mode.

Bit 7—Address 23 Enable (A23E): Enables PA_4 to be used as the A_{23} address output pin. Writing 0 in this bit enables A_{23} address output from PA_4 . In modes other than 3, 4, and 6 this bit cannot be modified and PA_4 has its ordinary input/output functions.

Bit 7: A23E	Description
0	PA_4 is the A_{23} address output pin
1	PA_4 is the $PA_4/TP_4/TIOCA_1$ input/output pin (Initial value)

Bit 6—Address 22 Enable (A22E): Enables PA_5 to be used as the A_{22} address output pin. Writing 0 in this bit enables A_{22} address output from PA_5 . In modes other than 3, 4, and 6 this bit cannot be modified and PA_5 has its ordinary input/output functions.

Bit 6: A22E	Description
0	PA_5 is the A_{22} address output pin
1	PA_5 is the $PA_5/TP_5/TIOCB_1$ input/output pin (Initial value)

Bit 5—Address 21 Enable (A21E): Enables PA_6 to be used as the A_{21} address output pin. Writing 0 in this bit enables A_{21} address output from PA_6 . In modes other than 3, 4, and 6 this bit cannot be modified and PA_6 has its ordinary input/output functions.

Bit 5: A21E	Description
0	PA_6 is the A_{21} address output pin
1	PA_6 is the $PA_6/TP_6/TIOCA_2$ input/output pin (Initial value)

Bits 4 to 1—Reserved: Read-only bits, always read as 1.

Bit 0—Bus Release Enable (BRLE): Enables or disables release of the bus to an external device.

Bit 0: BRLE	Description
0	The bus cannot be released to an external device; \overline{BREQ} and \overline{BACK} can be used as input/output pins (Initial value)
1	The bus can be released to an external device

6.2.6 Chip Select Control Register (CSCR)

CSCR is an 8-bit readable/writable register that enables or disables output of chip select signals (\overline{CS}_7 to \overline{CS}_4).

If a chip select signal (\overline{CS}_7 to \overline{CS}_4) output is selected in this register, the corresponding pin functions as a chip select signal (\overline{CS}_7 to \overline{CS}_4) output, this function taking priority over other functions. CSCR cannot be modified in single-chip mode.

Bit	7	6	5	4	3	2	1	0
	CS7E	CS6E	CS5E	CS4E	—	—	—	—
Initial value	0	0	0	0	1	1	1	1
Read/Write	R/W	R/W	R/W	R/W	—	—	—	—

Chip select 7 to 4 enable
These bits enable or disable
chip select signal output
Reserved bits

CSCR is initialized to H'0F by a reset and in hardware standby mode. It is not initialized in software standby mode.

Bits 7 to 4—Chip Select 7 to 4 Enable (CS7E to CS4E): These bits enable or disable output of the corresponding chip select signal.

Bit n: CSnE	Description
0	Output of chip select signal CS_n is disabled (Initial value)
1	Output of chip select signal CS_n is enabled

Note: n = 7 to 4

Bits 3 to 0—Reserved: Read-only bits, always read as 1.

6.3 Operation

6.3.1 Area Division

The external address space is divided into areas 0 to 7. Each area has a size of 128 kbytes in the 1-Mbyte modes, or 2 Mbytes in the 16-Mbyte modes. Figure 6.2 shows a general view of the memory map.

H'00000	Area 0 (128 kbytes)	H'000000	Area 0 (2 Mbytes)	H'00000	On-chip ROM*1	H'000000	On-chip ROM*1
H'1FFFFF		H'1FFFFF		H'1FFFFF	Area 0 (128 kbytes)	H'1FFFFF	Area 0 (2 Mbytes)
H'20000	Area 1 (128 kbytes)	H'200000	Area 1 (2 Mbytes)	H'20000	Area 1 (128 kbytes)	H'200000	Area 1 (2 Mbytes)
H'3FFFFF		H'3FFFFF		H'3FFFFF	Area 2 (128 kbytes)	H'3FFFFF	Area 2 (2 Mbytes)
H'40000	Area 2 (128 kbytes)	H'400000	Area 2 (2 Mbytes)	H'40000	Area 2 (128 kbytes)	H'400000	Area 2 (2 Mbytes)
H'5FFFFF		H'5FFFFF		H'5FFFFF	Area 3 (128 kbytes)	H'5FFFFF	Area 3 (2 Mbytes)
H'60000	Area 3 (128 kbytes)	H'600000	Area 3 (2 Mbytes)	H'60000	Area 3 (128 kbytes)	H'600000	Area 3 (2 Mbytes)
H'7FFFFF		H'7FFFFF		H'7FFFFF	Area 4 (128 kbytes)	H'7FFFFF	Area 4 (2 Mbytes)
H'80000	Area 4 (128 kbytes)	H'800000	Area 4 (2 Mbytes)	H'80000	Area 4 (128 kbytes)	H'800000	Area 4 (2 Mbytes)
H'9FFFFF		H'9FFFFF		H'9FFFFF	Area 5 (128 kbytes)	H'9FFFFF	Area 5 (2 Mbytes)
H'A0000	Area 5 (128 kbytes)	H'A00000	Area 5 (2 Mbytes)	H'A0000	Area 5 (128 kbytes)	H'A00000	Area 5 (2 Mbytes)
H'BFFFFF		H'BFFFFF		H'BFFFFF	Area 6 (128 kbytes)	H'BFFFFF	Area 6 (2 Mbytes)
H'C0000	Area 6 (128 kbytes)	H'C00000	Area 6 (2 Mbytes)	H'C0000	Area 6 (128 kbytes)	H'C00000	Area 6 (2 Mbytes)
H'DFFFFF		H'DFFFFF		H'DFFFFF	Area 7 (128 kbytes)	H'DFFFFF	Area 7 (2 Mbytes)
H'E0000	Area 7 (128 kbytes)	H'E00000	Area 7 (2 Mbytes)	H'E0000	Area 7 (128 kbytes)	H'E00000	Area 7 (2 Mbytes)
	On-chip RAM*1*2		On-chip RAM*1*2		On-chip RAM*1*2		On-chip RAM*1*2
	External address space*3		External address space*3		External address space*3		External address space*3
H'FFFFFF	Internal I/O registers*1	H'FFFFFF	Internal I/O registers*1	H'FFFFFF	Internal I/O registers*1	H'FFFFFF	Internal I/O registers*1

a. 1-Mbyte modes with on-chip ROM disabled (modes 1 and 2)

b. 16-Mbyte modes with on-chip ROM disabled (modes 3 and 4)

c. 1-Mbyte mode with on-chip ROM enabled (mode 5)

d. 16-Mbyte mode with on-chip ROM enabled (mode 6)

Notes: 1. The on-chip ROM, on-chip RAM, and internal I/O registers have a fixed bus width and are accessed in a fixed number of states.
 2. When the RAME bit is cleared to 0 in SYSCR, this area conforms to the specifications of area 7.
 3. This external address area conforms to the specifications of area 7.

Figure 6.2 Access Area Map for Modes 1 to 6

Chip select signals (\overline{CS}_7 to \overline{CS}_0) can be output for areas 7 to 0. The bus specifications for each area can be selected in ABWCR, ASTCR, WCER, and WCR as shown in table 6.3.

Table 6.3 Bus Specifications

ABWCR	ASTCR	WCER	WCR		Bus Specifications			
					Bus Width	Access States	Wait Mode	
ABWn	ASTn	WCEn	WMS1	WMS0				
0	0	—	—	—	16	2	Disabled	
		1	0	—	16	3	Pin wait mode 0	
	1	0	0	0	0	16	3	Programmable wait mode
				1	1	16	3	Disabled
		0	0	0	0	16	3	Pin wait mode 1
				1	1	16	3	Pin auto-wait mode
1	0	—	—	—	8	2	Disabled	
		1	0	—	8	3	Pin wait mode 0	
	1	0	0	0	0	8	3	Programmable wait mode
				1	1	8	3	Disabled
		0	0	0	0	8	3	Pin wait mode 1
				1	1	8	3	Pin auto-wait mode

Note: n = 0 to 7

6.3.2 Chip Select Signals

For each of areas 7 to 0, the H8/3048B Group can output a chip select signal (\overline{CS}_7 to \overline{CS}_0) that goes low to indicate when the area is selected. Figure 6.3 shows the output timing of a \overline{CS}_n signal ($n = 0$ to 7).

Output of \overline{CS}_3 to \overline{CS}_0 : Output of \overline{CS}_3 to \overline{CS}_0 is enabled or disabled in the data direction register (DDR) of the corresponding port.

In the expanded modes with on-chip ROM disabled, a reset leaves pin \overline{CS}_0 in the output state and pins \overline{CS}_3 to \overline{CS}_1 in the input state. To output chip select signals \overline{CS}_3 to \overline{CS}_1 , the corresponding DDR bits must be set to 1. In the expanded modes with on-chip ROM enabled, a reset leaves pins \overline{CS}_3 to \overline{CS}_0 in the input state. To output chip select signals \overline{CS}_3 to \overline{CS}_0 , the corresponding DDR bits must be set to 1. For details see section 9, I/O Ports.

Output of \overline{CS}_7 to \overline{CS}_4 : Output of \overline{CS}_7 to \overline{CS}_4 is enabled or disabled in the chip select control register (CSCR). A reset leaves pins \overline{CS}_7 to \overline{CS}_4 in the input state. To output chip select signals \overline{CS}_7 to \overline{CS}_4 , the corresponding CSCR bits must be set to 1. For details see section 9, I/O Ports.

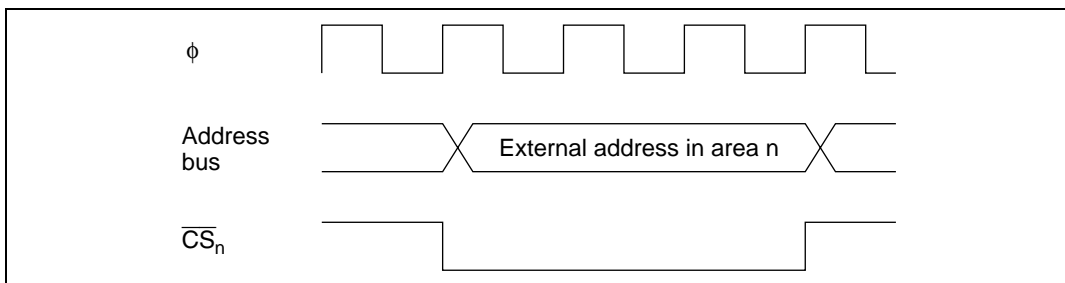

Figure 6.3 \overline{CS}_n Output Timing ($n = 7$ to 0)

When the on-chip ROM, on-chip RAM, and internal I/O registers are accessed, \overline{CS}_7 and \overline{CS}_0 remain high. The \overline{CS}_n signals are decoded from the address signals. They can be used as chip select signals for SRAM and other devices.

6.3.3 Data Bus

The H8/3048B Group allows either 8-bit access or 16-bit access to be designated for each of areas 7 to 0. An 8-bit-access area uses the upper data bus (D_{15} to D_8). A 16-bit-access area uses both the upper data bus (D_{15} to D_8) and lower data bus (D_7 to D_0).

In read access the \overline{RD} signal applies without distinction to both the upper and lower data bus. In write access the \overline{HWR} signal applies to the upper data bus, and the \overline{LWR} signal applies to the lower data bus.

Table 6.4 indicates how the two parts of the data bus are used under different access conditions.

Table 6.4 Access Conditions and Data Bus Usage

Area	Access Size	Read/Write	Address	Valid Strobe	Upper Data Bus (D_{15} to D_8)	Lower Data Bus (D_7 to D_0)
8-bit-access area	—	Read	—	\overline{RD}	Valid	Invalid
		Write	—	\overline{HWR}		Undetermined data
16-bit-access area	Byte	Read	Even	\overline{RD}	Valid	Invalid
			Odd		Invalid	Valid
		Write	Even	\overline{HWR}	Valid	Undetermined data
			Odd	\overline{LWR}	Undetermined data	Valid
	Word	Read	—	\overline{RD}	Valid	Valid
		Write	—		\overline{HWR} , \overline{LWR}	Valid

Note: Undetermined data means that unpredictable data is output.

Invalid means that the bus is in the input state and the input is ignored.

6.3.4 Bus Control Signal Timing

8-Bit, Three-State-Access Areas

Figure 6.4 shows the timing of bus control signals for an 8-bit, three-state-access area. The upper address bus (D_{15} to D_8) is used to access these areas. The \overline{LWR} pin is always high. Wait states can be inserted.

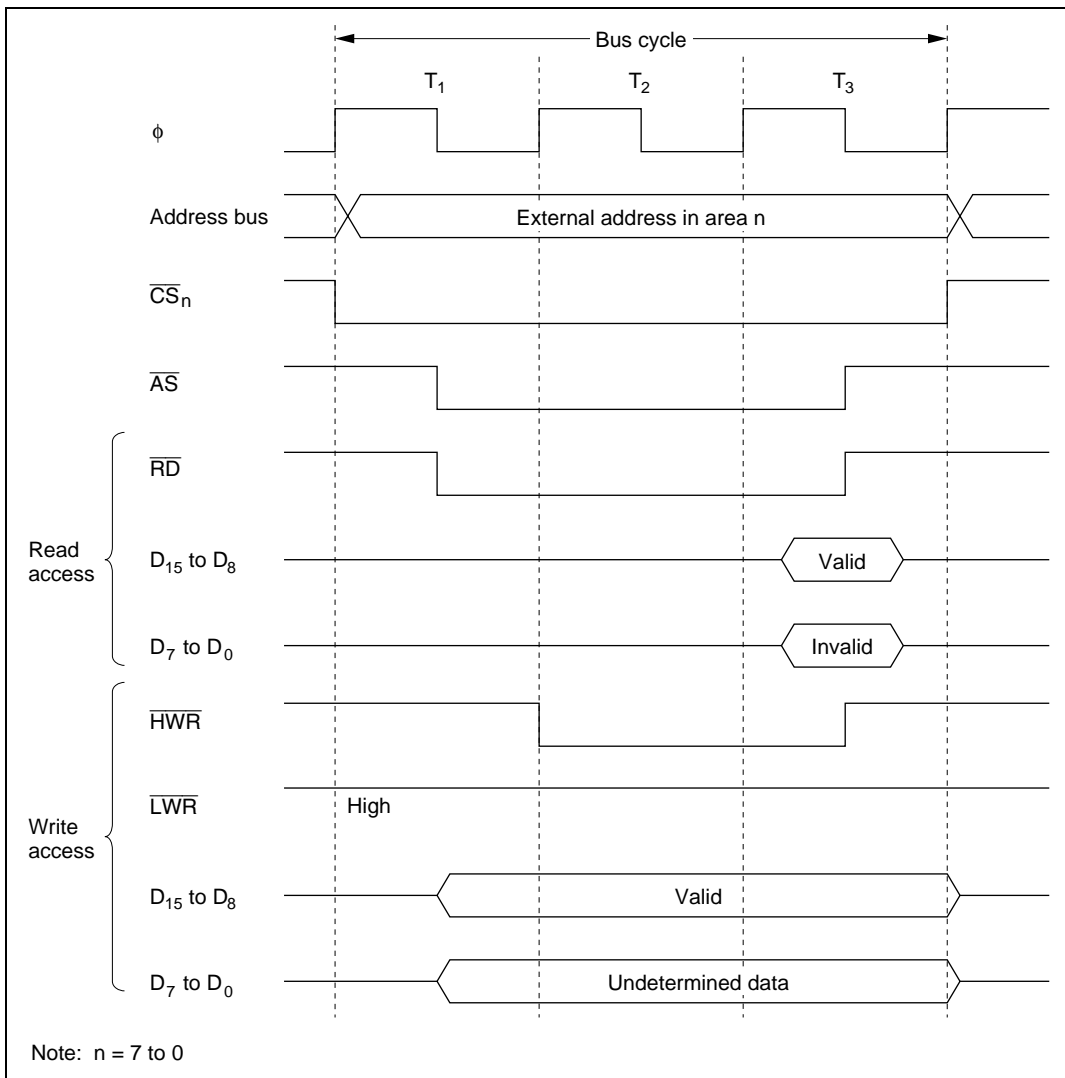

Figure 6.4 Bus Control Signal Timing for 8-Bit, Three-State-Access Area

8-Bit, Two-State-Access Areas

Figure 6.5 shows the timing of bus control signals for an 8-bit, two-state-access area. The upper address bus (D_{15} to D_8) is used to access these areas. The \overline{LWR} pin is always high. Wait states cannot be inserted.

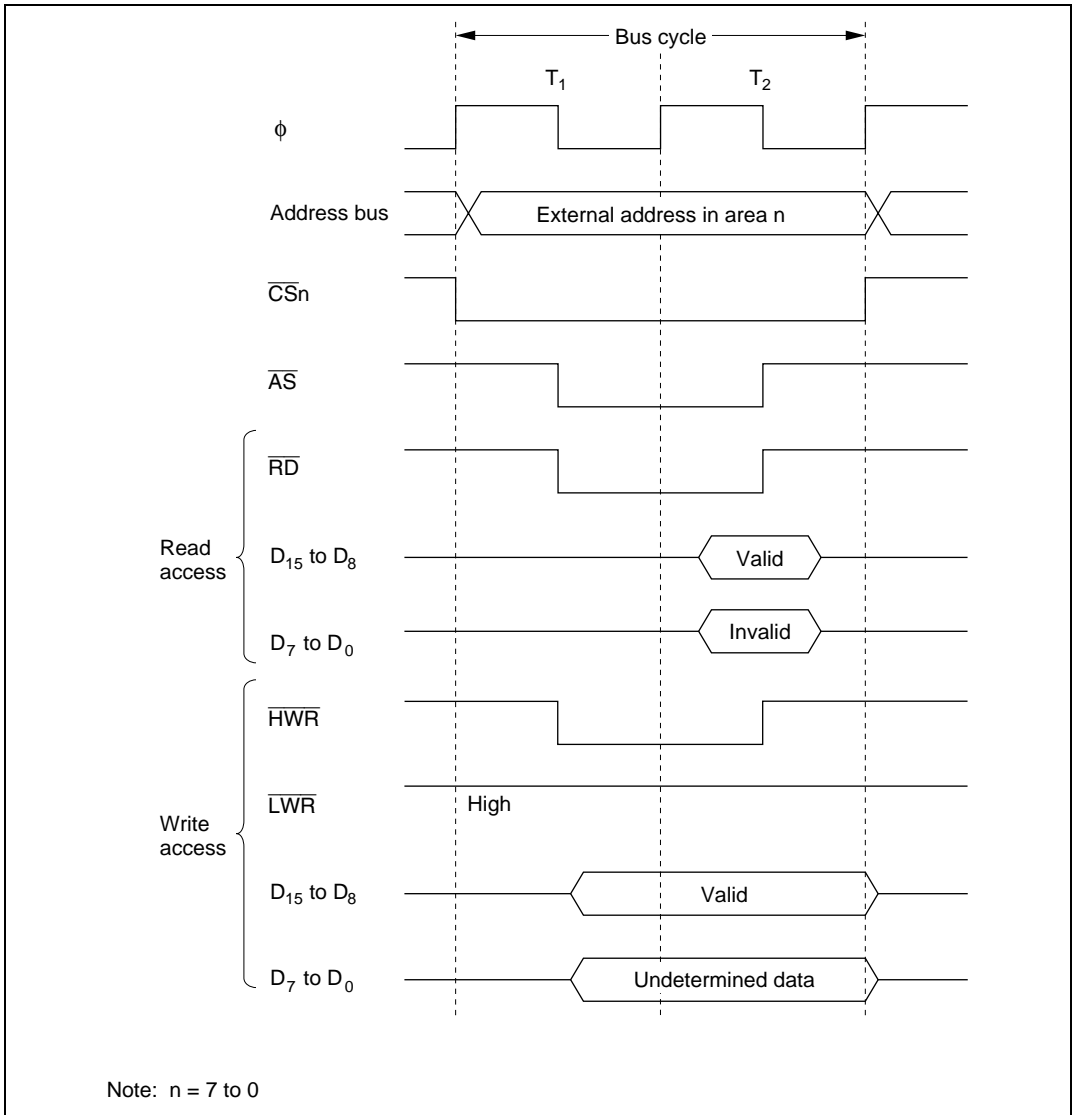

Figure 6.5 Bus Control Signal Timing for 8-Bit, Two-State-Access Area

16-Bit, Three-State-Access Areas

Figures 6.6 to 6.8 show the timing of bus control signals for a 16-bit, three-state-access area. In these areas, the upper address bus (D_{15} to D_8) is used to access even addresses and the lower address bus (D_7 to D_0) is used to access odd addresses. Wait states can be inserted.

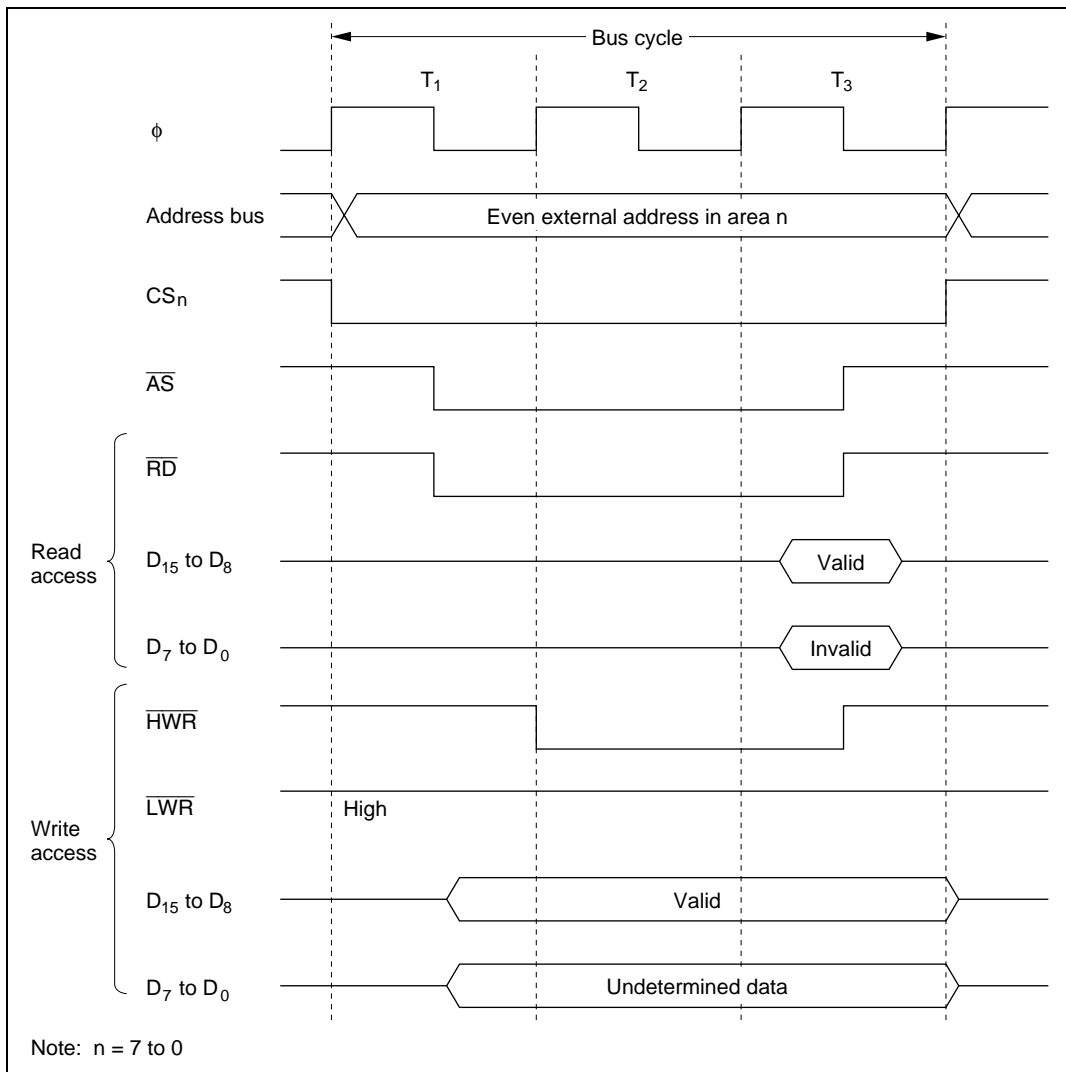
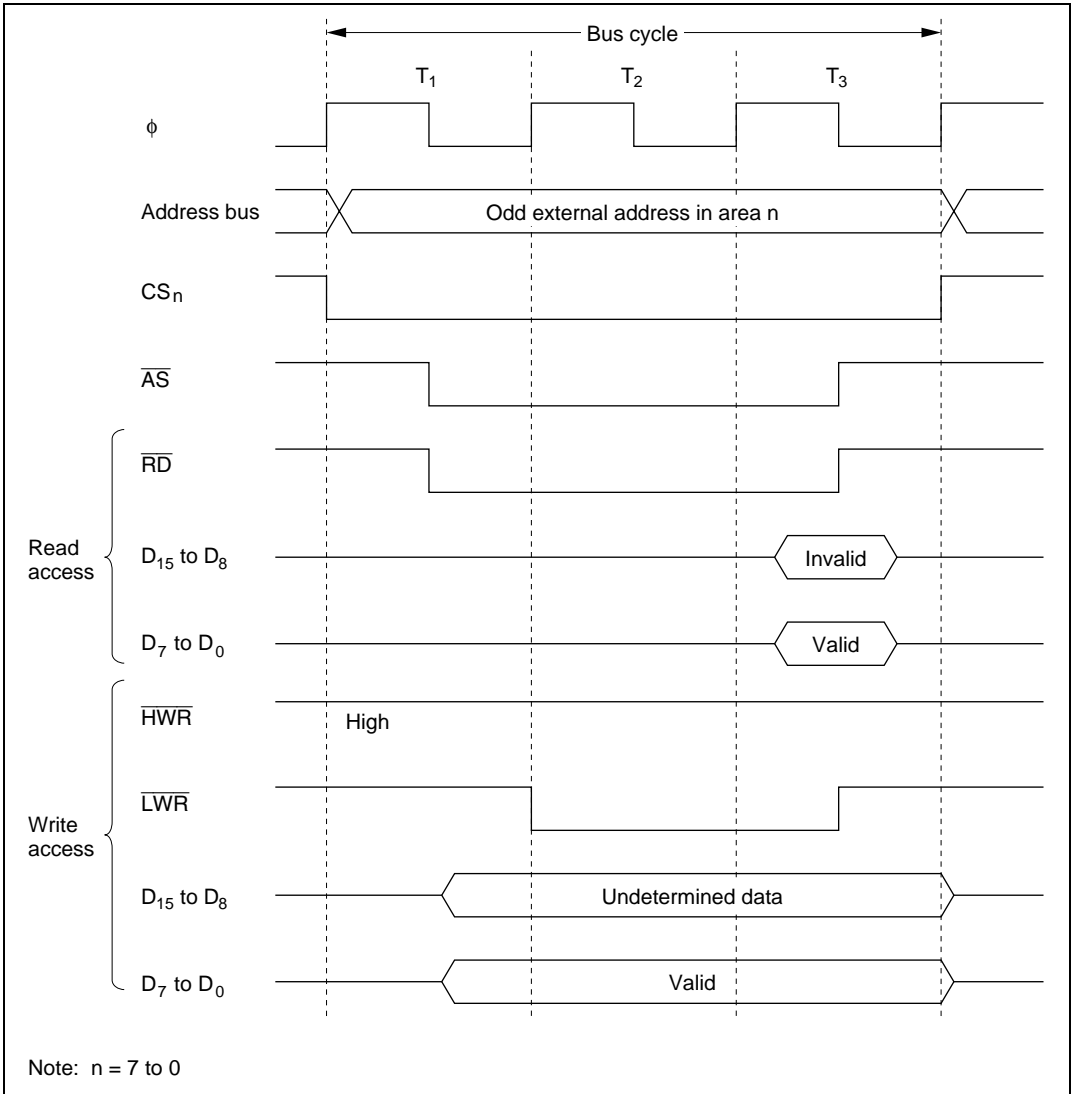
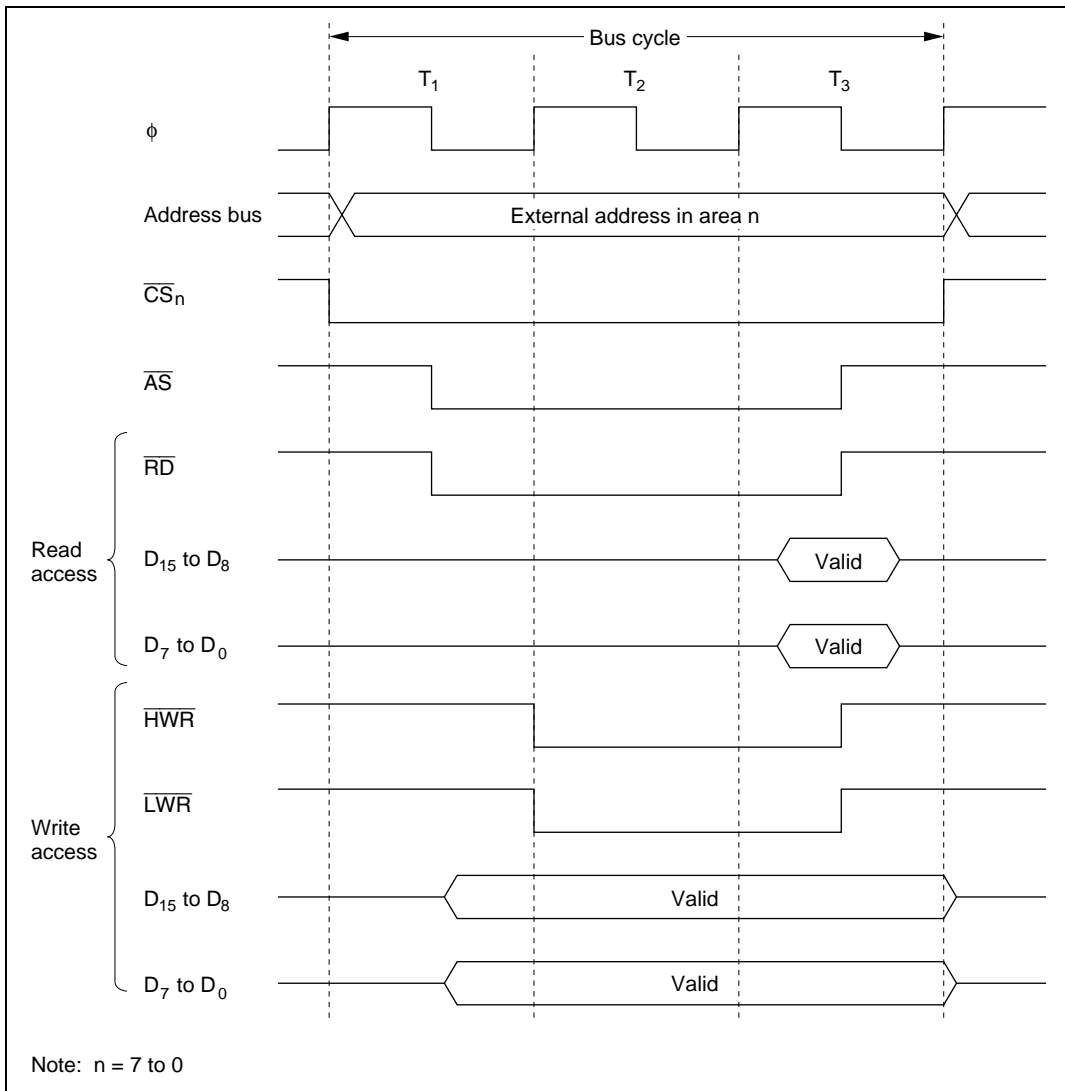

Figure 6.6 Bus Control Signal Timing for 16-Bit, Three-State-Access Area (1)
(Byte Access to Even Address)



**Figure 6.7 Bus Control Signal Timing for 16-Bit, Three-State-Access Area (2)
(Byte Access to Odd Address)**



**Figure 6.8 Bus Control Signal Timing for 16-Bit, Three-State-Access Area (3)
(Word Access)**

16-Bit, Two-State-Access Areas

Figures 6.9 to 6.11 show the timing of bus control signals for a 16-bit, two-state-access area. In these areas, the upper address bus (D_{15} to D_8) is used to access even addresses and the lower address bus (D_7 to D_0) is used to access odd addresses. Wait states cannot be inserted.

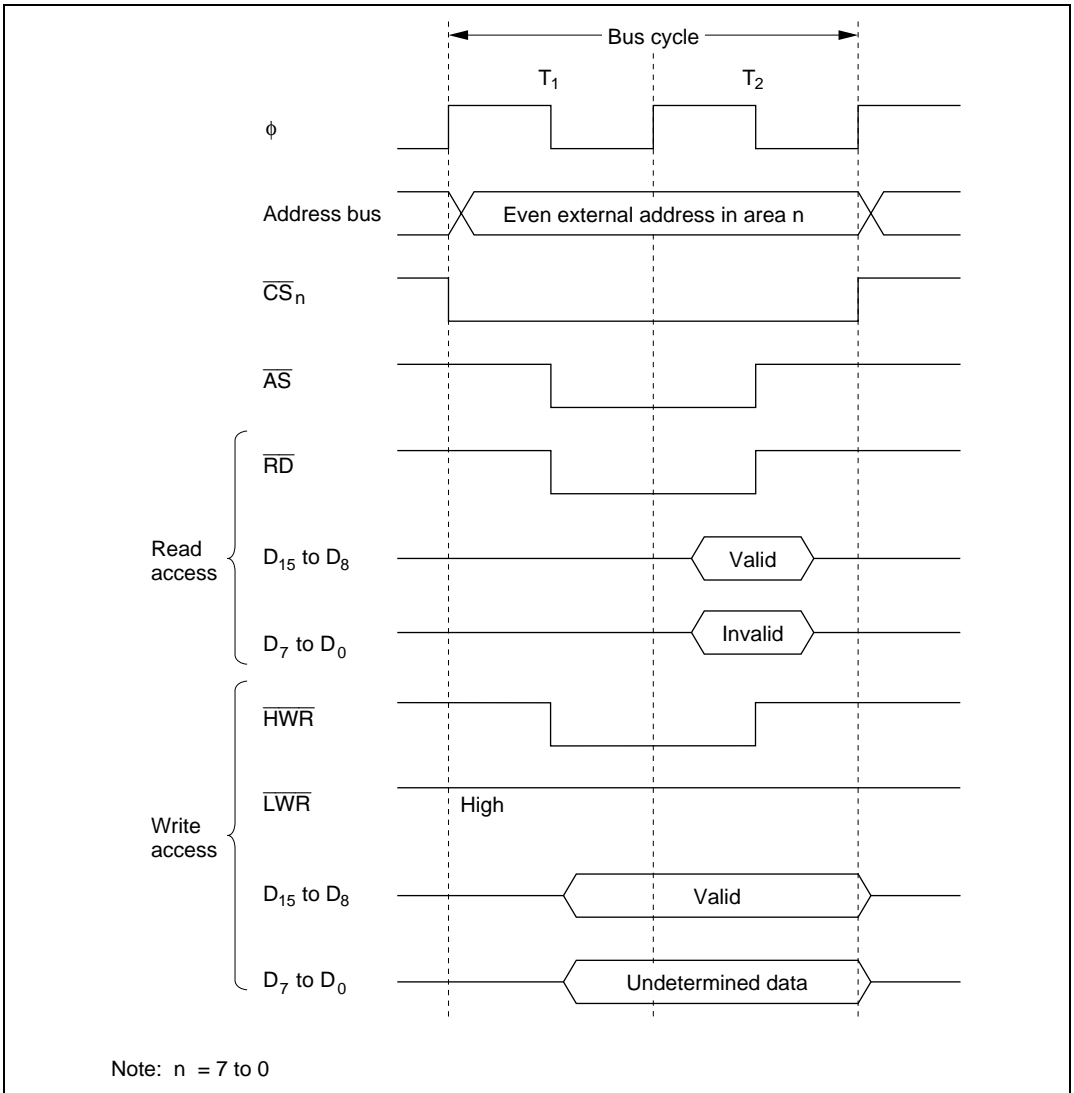
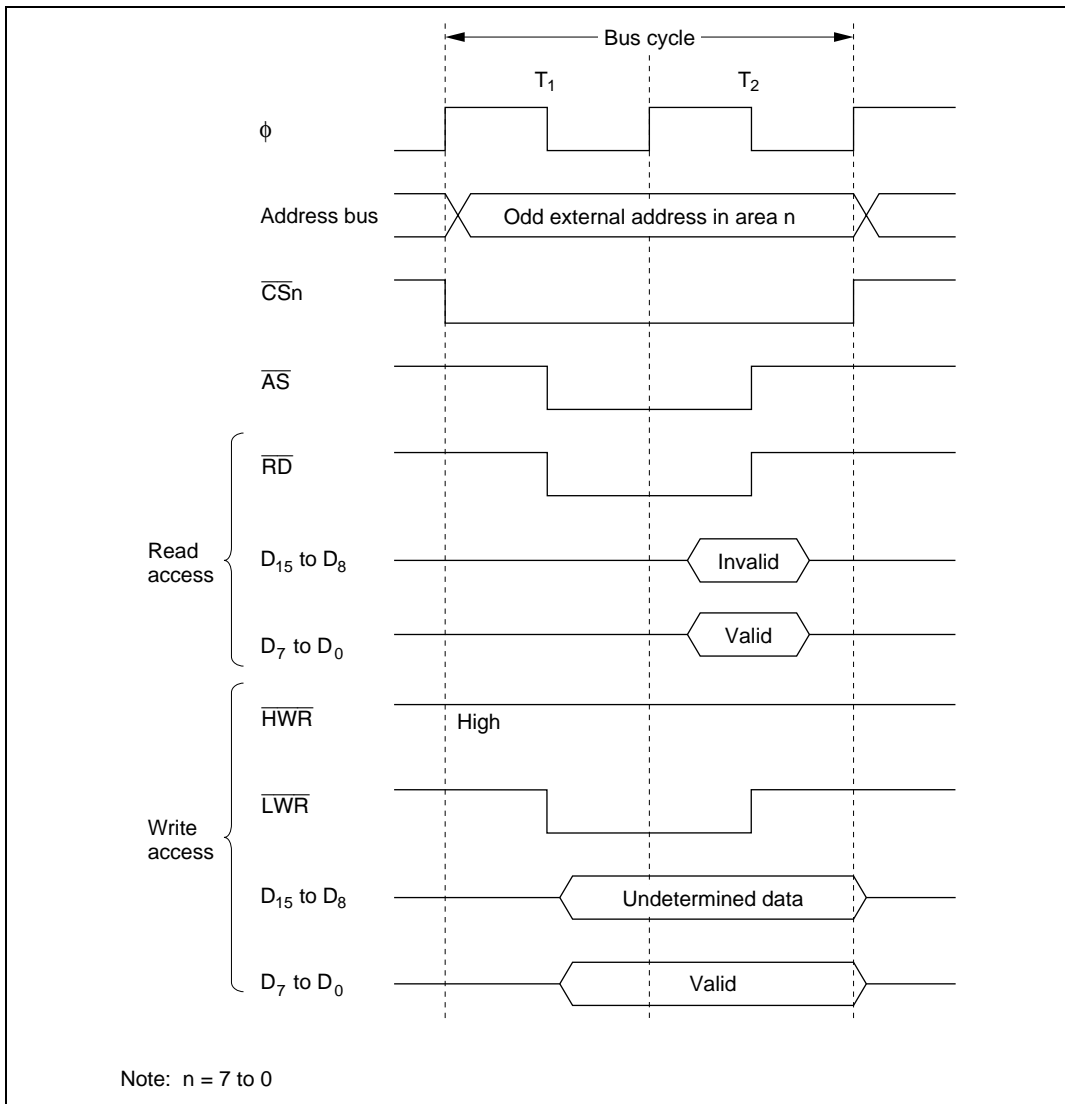
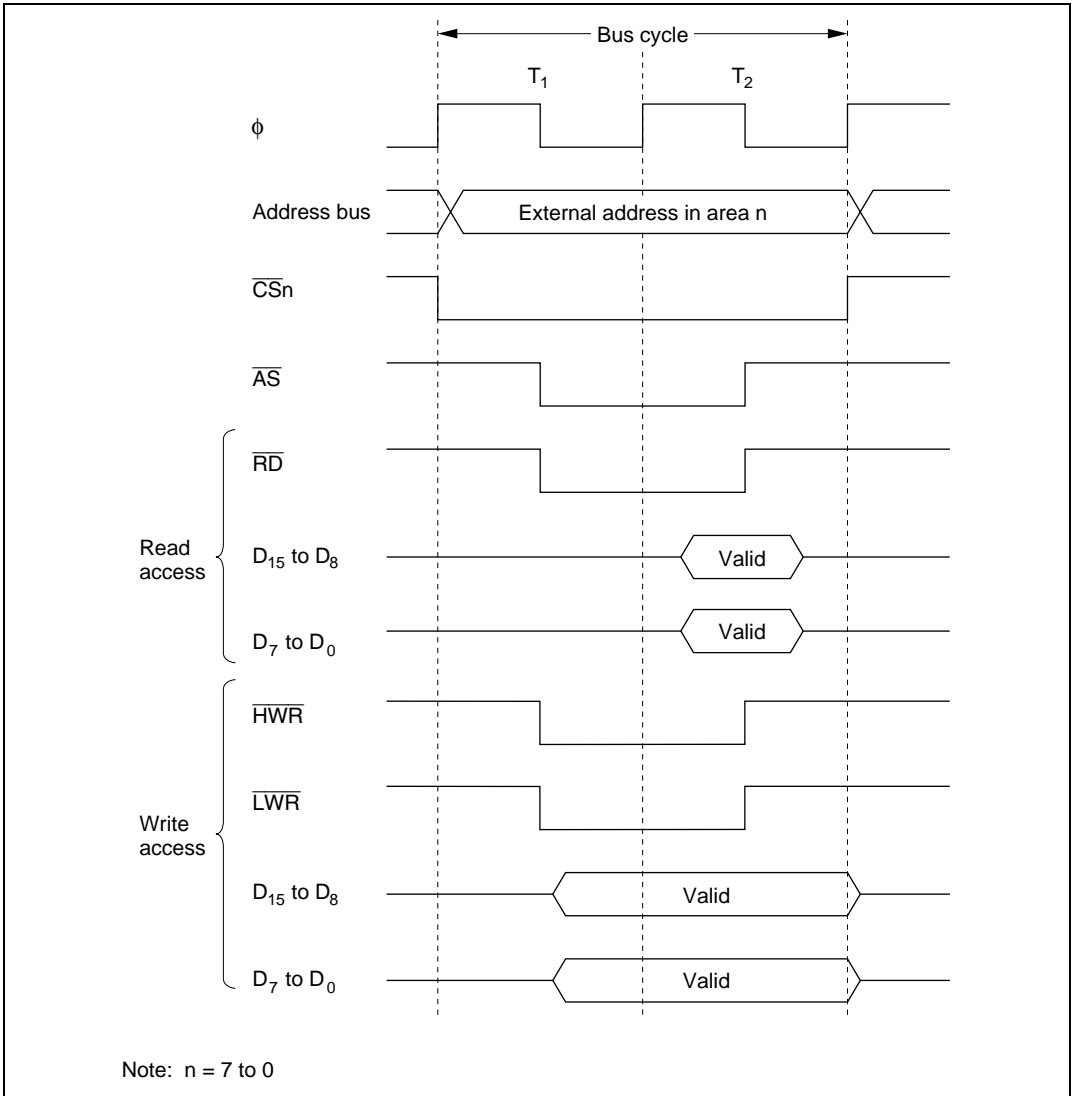

Figure 6.9 Bus Control Signal Timing for 16-Bit, Two-State-Access Area (1)
(Byte Access to Even Address)



**Figure 6.10 Bus Control Signal Timing for 16-Bit, Two-State-Access Area (2)
(Byte Access to Odd Address)**



**Figure 6.11 Bus Control Signal Timing for 16-Bit, Two-State-Access Area (3)
(Word Access)**

6.3.5 Wait Modes

Four wait modes can be selected as shown in table 6.5.

Table 6.5 Wait Mode Selection

ASTCR	WCER	WCR		WSC Control	Wait Mode
ASTn Bit	WCEn Bit	WMS1 Bit	WMS0 Bit		
0	—	—	—	Disabled	No wait states
1	0	—	—	Disabled	Pin wait mode 0
		1	0	0	Enabled
	1		1	1	Enabled
	1	0	1	Enabled	Pin wait mode 1
			1	Enabled	Pin auto-wait mode

Note: n = 7 to 0

Wait Mode in Areas Where Wait-State Controller is Disabled

External three-state access areas in which the wait-state controller is disabled ($ASTn = 1$, $WCEn = 0$) operate in pin wait mode 0. The other wait modes are unavailable. The settings of bits $WMS1$ and $WMS0$ are ignored in these areas.

Pin Wait Mode 0: Wait states can only be inserted by \overline{WAIT} pin control. During access to an external three-state-access area, if the \overline{WAIT} pin is low at the fall of the system clock (ϕ) in the T_2 state, a wait state (T_w) is inserted. If the \overline{WAIT} pin remains low, wait states continue to be inserted until the \overline{WAIT} signal goes high. Figure 6.12 shows the timing.

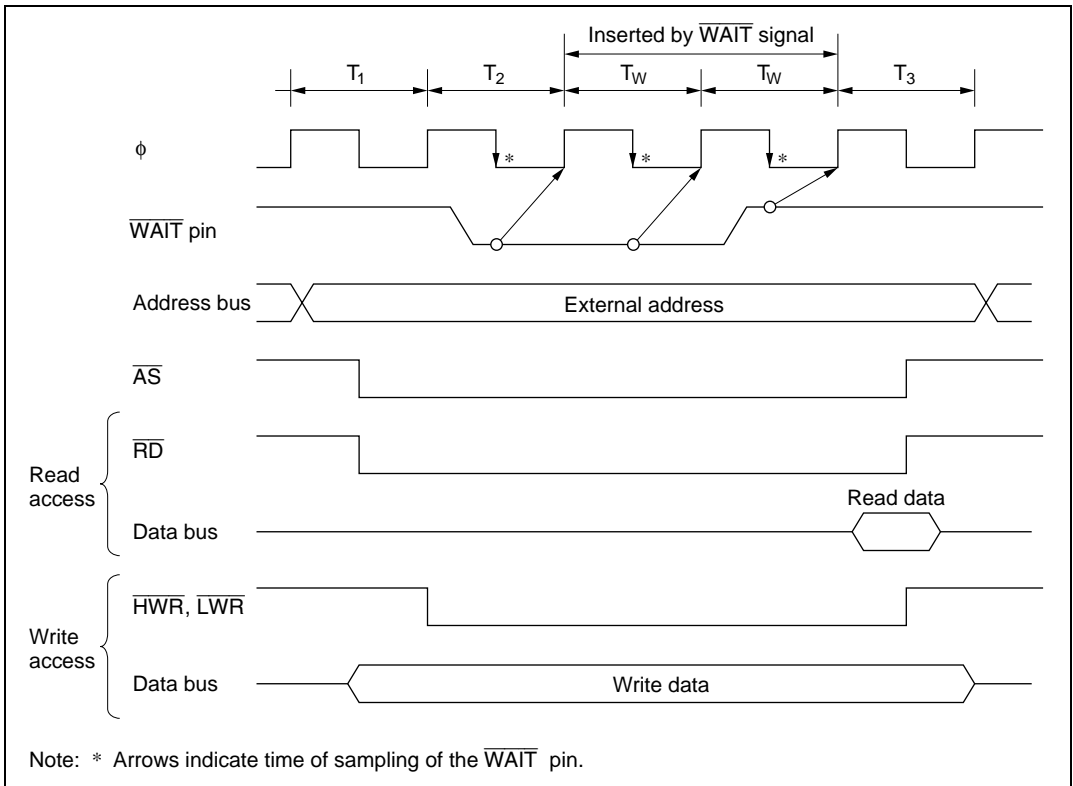

Figure 6.12 Pin Wait Mode 0

Wait Modes in Areas Where Wait-State Controller is Enabled

External three-state access areas in which the wait-state controller is enabled ($\text{ASTn} = 1$, $\text{WCEn} = 1$) can operate in pin wait mode 1, pin auto-wait mode, or programmable wait mode, as selected by bits WMS1 and WMS0 . Bits WMS1 and WMS0 apply to all areas, so all areas in which the wait-state controller is enabled operate in the same wait mode.

Pin Wait Mode 1: In all accesses to external three-state-access areas, the number of wait states (T_w) selected by bits WC1 and WC0 are inserted. If the $\overline{\text{WAIT}}$ pin is low at the fall of the system clock (ϕ) in the last of these wait states, an additional wait state is inserted. If the $\overline{\text{WAIT}}$ pin remains low, wait states continue to be inserted until the $\overline{\text{WAIT}}$ signal goes high.

Pin wait mode 1 is useful for inserting four or more wait states, or for inserting different numbers of wait states for different external devices.

If the wait count is 0, this mode operates in the same way as pin wait mode 0.

Figure 6.13 shows the timing when the wait count is 1 ($WC1 = 0$, $WC0 = 1$) and one additional wait state is inserted by \overline{WAIT} input.

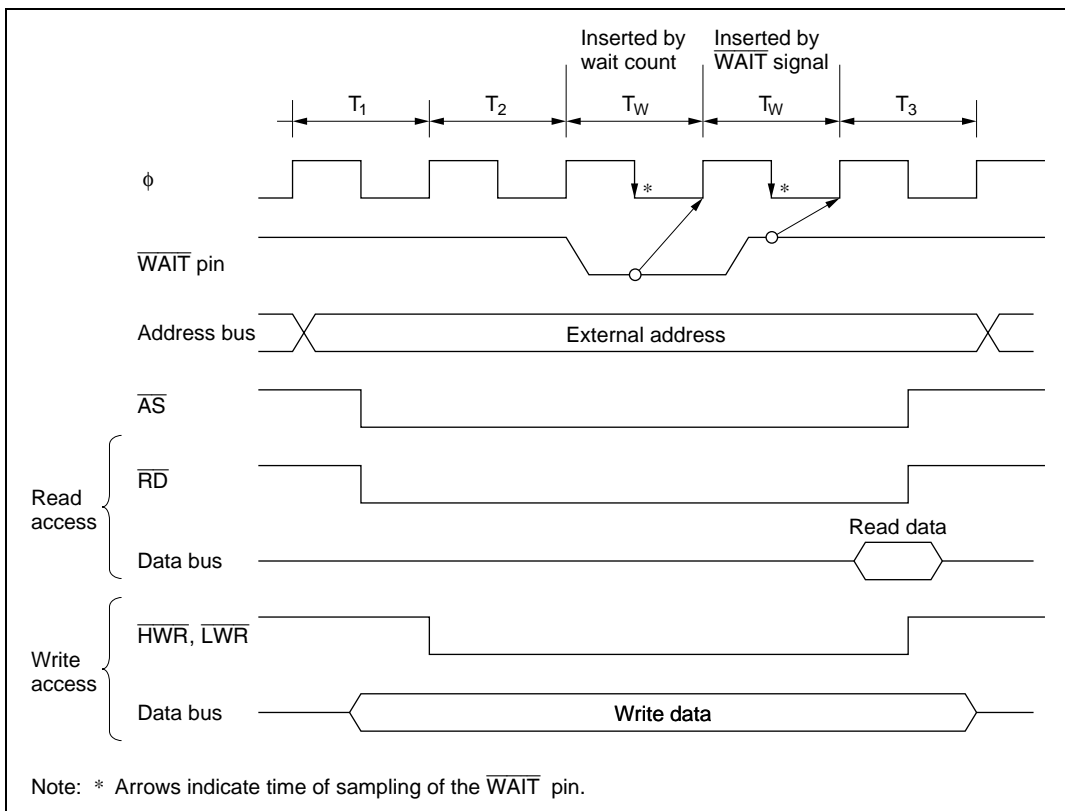

Figure 6.13 Pin Wait Mode 1

Pin Auto-Wait Mode: If the $\overline{\text{WAIT}}$ pin is low, the number of wait states (T_w) selected by bits WC1 and WC0 are inserted.

In pin auto-wait mode, if the $\overline{\text{WAIT}}$ pin is low at the fall of the system clock (ϕ) in the T_2 state, the number of wait states (T_w) selected by bits WC1 and WC0 are inserted. No additional wait states are inserted even if the $\overline{\text{WAIT}}$ pin remains low. Pin auto-wait mode can be used for an easy interface to low-speed memory, simply by routing the chip select signal to the $\overline{\text{WAIT}}$ pin.

Figure 6.14 shows the timing when the wait count is 1.

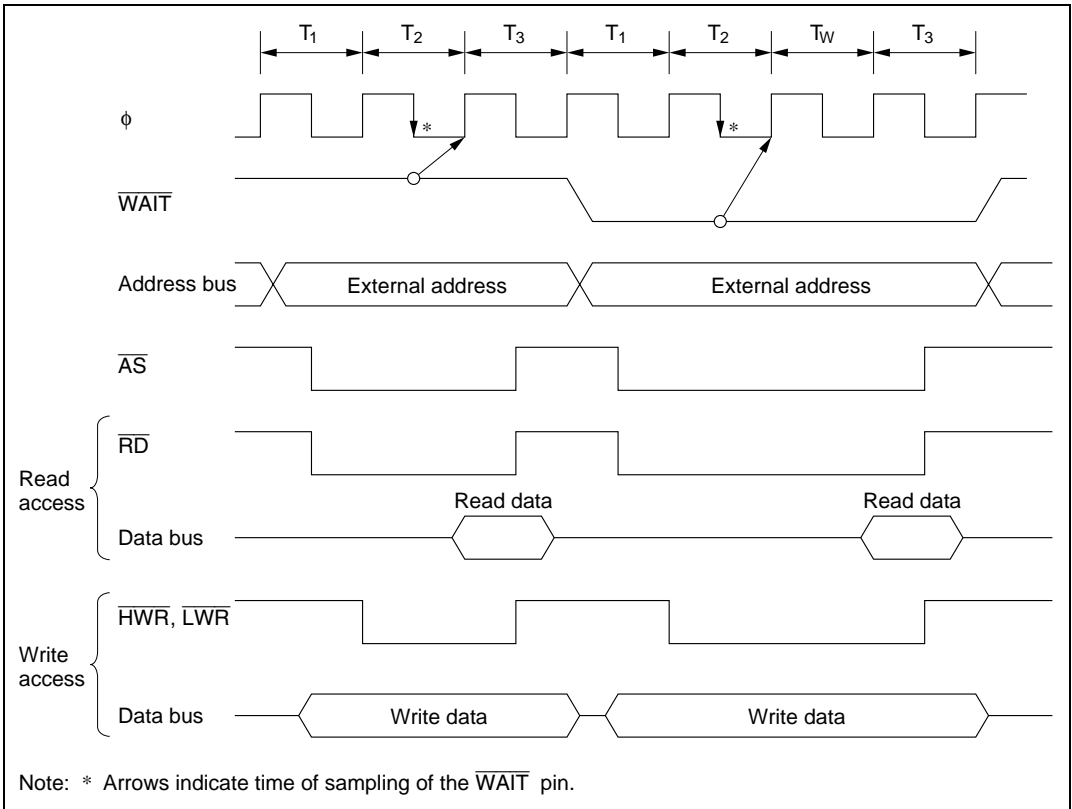

Figure 6.14 Pin Auto-Wait Mode

Programmable Wait Mode: The number of wait states (T_w) selected by bits WC1 and WC0 are inserted in all accesses to external three-state-access areas. Figure 6.15 shows the timing when the wait count is 1 ($WC1 = 0, WC0 = 1$).

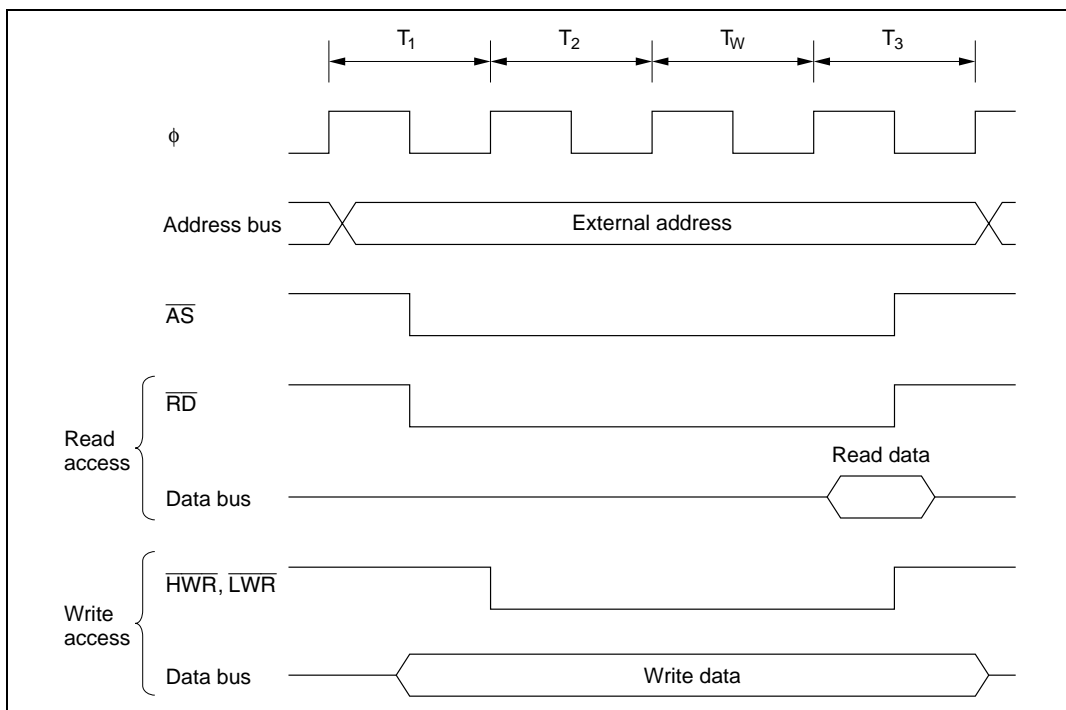

Figure 6.15 Programmable Wait Mode

Example of Wait State Control Settings

A reset initializes ASTCR and WCER to H'FF and WCR to H'F3, selecting programmable wait mode and three wait states for all areas. Software can select other wait modes for individual areas by modifying the ASTCR, WCER, and WCR settings. Figure 6.16 shows an example of wait mode settings.

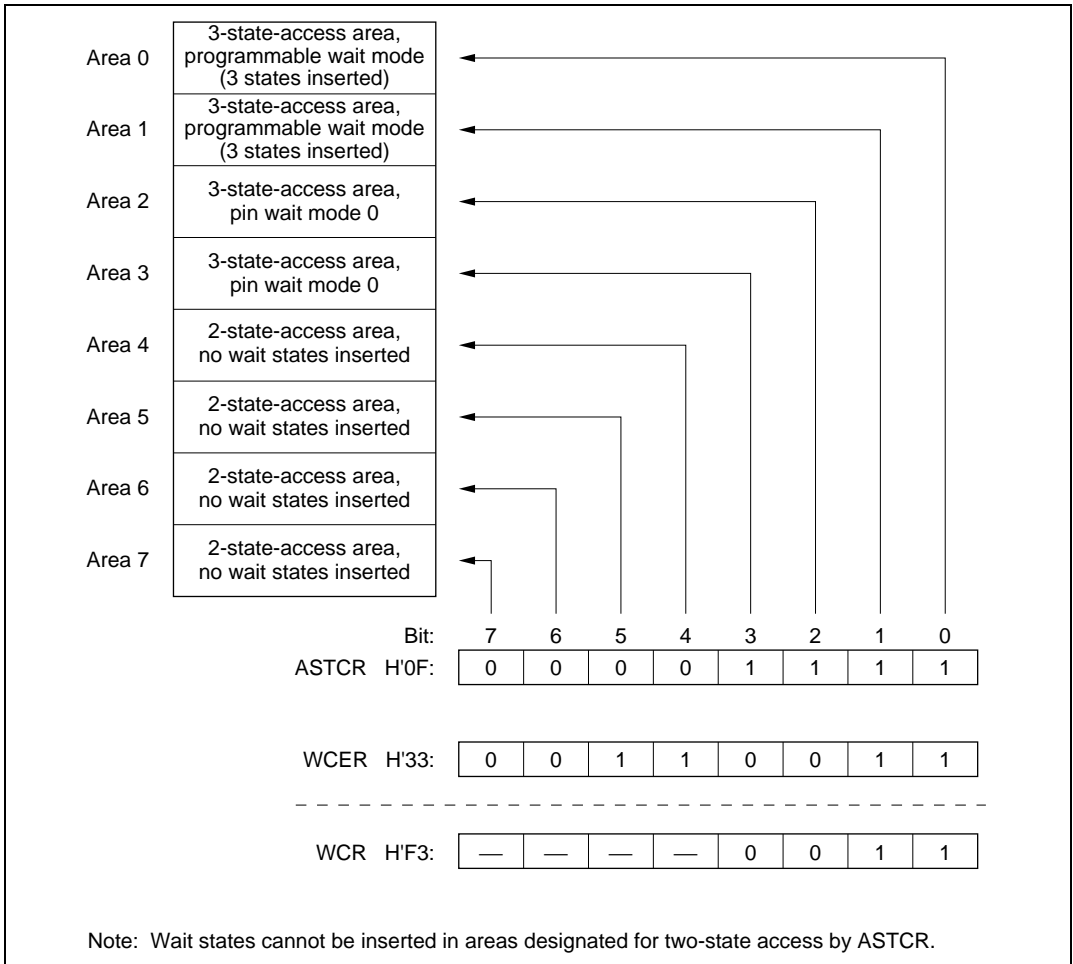

Figure 6.16 Wait Mode Settings (Example)

6.3.6 Interconnections with Memory (Example)

For each area, the bus controller can select two- or three-state access and an 8- or 16-bit data bus width. In three-state-access areas, wait states can be inserted in a variety of modes, simplifying the connection of both high-speed and low-speed devices.

Figure 6.18 shows an example of interconnections between the H8/3048B Group and memory. Figure 6.17 shows a memory map for this example.

A 256-kword \times 16-bit EPROM is connected to area 0. This device is accessed in three states via a 16-bit bus.

Two 32-kword \times 8-bit SRAM devices (SRAM1 and SRAM2) are connected to area 1. These devices are accessed in two states via a 16-bit bus.

One 32-kword \times 8-bit SRAM (SRAM3) is connected to area 2. This device is accessed via an 8-bit bus, using three-state access with an additional wait state inserted in pin auto-wait mode.

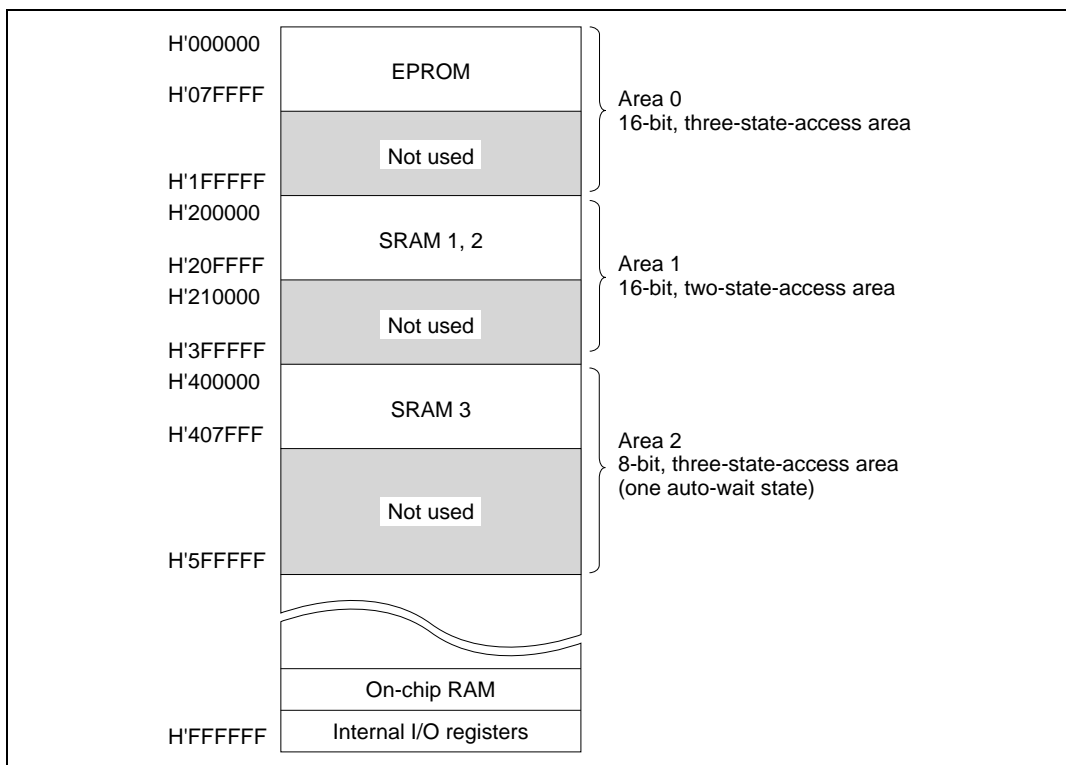

Figure 6.17 Memory Map (Example)

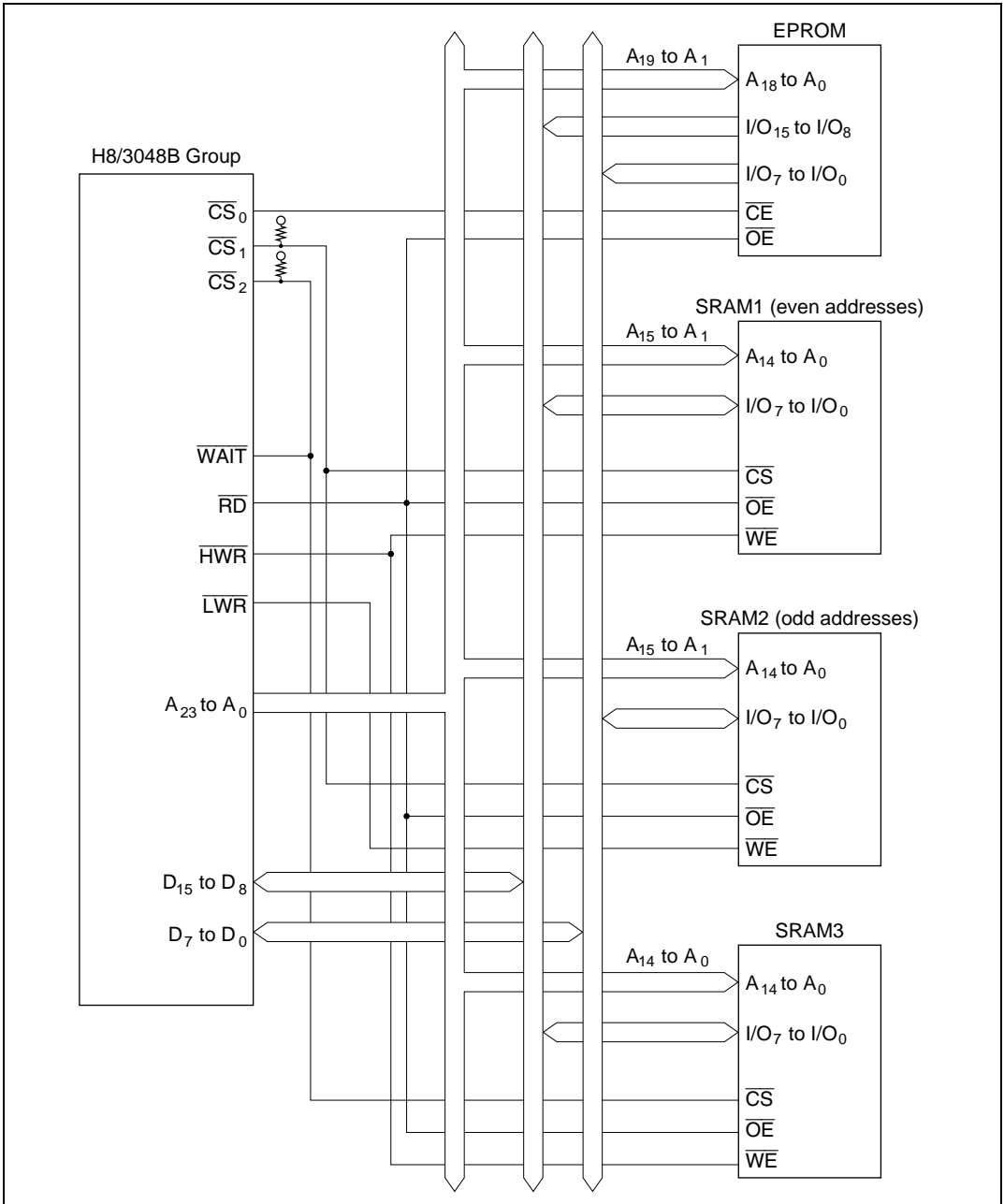

Figure 6.18 Interconnections with Memory (Example)

6.3.7 Bus Arbiter Operation

The bus controller has a built-in bus arbiter that arbitrates between different bus masters. There are four bus masters: the CPU, DMA controller (DMAC), refresh controller, and an external bus master. When a bus master has the bus right it can carry out read, write, or refresh access. Each bus master uses a bus request signal to request the bus right. At fixed times the bus arbiter determines priority and uses a bus acknowledge signal to grant the bus to a bus master, which can then operate using the bus.

The bus arbiter checks whether the bus request signal from a bus master is active or inactive, and returns an acknowledge signal to the bus master if the bus request signal is active. When two or more bus masters request the bus, the highest-priority bus master receives an acknowledge signal. The bus master that receives an acknowledge signal can continue to use the bus until the acknowledge signal is deactivated.

The bus master priority order is:

(High) External bus master > refresh controller > DMAC > CPU (Low)

The bus arbiter samples the bus request signals and determines priority at all times, but it does not always grant the bus immediately, even when it receives a bus request from a bus master with higher priority than the current bus master. Each bus master has certain times at which it can release the bus to a higher-priority bus master.

CPU

The CPU is the lowest-priority bus master. If the DMAC, refresh controller, or an external bus master requests the bus while the CPU has the bus right, the bus arbiter transfers the bus right to the bus master that requested it. The bus right is transferred at the following times:

- The bus right is transferred at the boundary of a bus cycle. If word data is accessed by two consecutive byte accesses, however, the bus right is not transferred between the two byte accesses.
- If another bus master requests the bus while the CPU is performing internal operations, such as executing a multiply or divide instruction, the bus right is transferred immediately. The CPU continues its internal operations.
- If another bus master requests the bus while the CPU is in sleep mode, the bus right is transferred immediately.

DMAC

When the DMAC receives an activation request, it requests the bus right from the bus arbiter. If the DMAC is bus master and the refresh controller or an external bus master requests the bus, the bus arbiter transfers the bus right from the DMAC to the bus master that requested the bus. The bus right is transferred at the following times.

The bus right is transferred when the DMAC finishes transferring 1 byte or 1 word. A DMAC transfer cycle consists of a read cycle and a write cycle. The bus right is not transferred between the read cycle and the write cycle.

There is a priority order among the DMAC channels. For details see section 8.4.9, DMAC Multiple-Channel Operation.

Refresh Controller

When a refresh cycle is requested, the refresh controller requests the bus right from the bus arbiter. When the refresh cycle is completed, the refresh controller releases the bus. For details see section 7, Refresh Controller.

External Bus Master

When the BRLE bit is set to 1 in BRCCR, the bus can be released to an external bus master. The external bus master has highest priority, and requests the bus right from the bus arbiter by driving the $\overline{\text{BREQ}}$ signal low. Once the external bus master gets the bus, it keeps the bus right until the $\overline{\text{BREQ}}$ signal goes high. While the bus is released to an external bus master, the H8/3048B Group holds the address bus and data bus control signals ($\overline{\text{AS}}$, $\overline{\text{RD}}$, $\overline{\text{HWR}}$, and $\overline{\text{LWR}}$) in the high-impedance state, holds the chip select signals high ($\overline{\text{CS}}_n$; $n = 7$ to 0), and holds the $\overline{\text{BACK}}$ pin in the low output state.

The bus arbiter samples the $\overline{\text{BREQ}}$ pin at the rise of the system clock (ϕ). If $\overline{\text{BREQ}}$ is low, the bus is released to the external bus master at the appropriate opportunity. The $\overline{\text{BREQ}}$ signal should be held low until the $\overline{\text{BACK}}$ signal goes low.

When the $\overline{\text{BREQ}}$ pin is high in two consecutive samples, the $\overline{\text{BACK}}$ signal is driven high to end the bus-release cycle.

Figure 6.19 shows the timing when the bus right is requested by an external bus master during a read cycle in a two-state-access area. There is a minimum interval of two states from when the $\overline{\text{BREQ}}$ signal goes low until the bus is released.

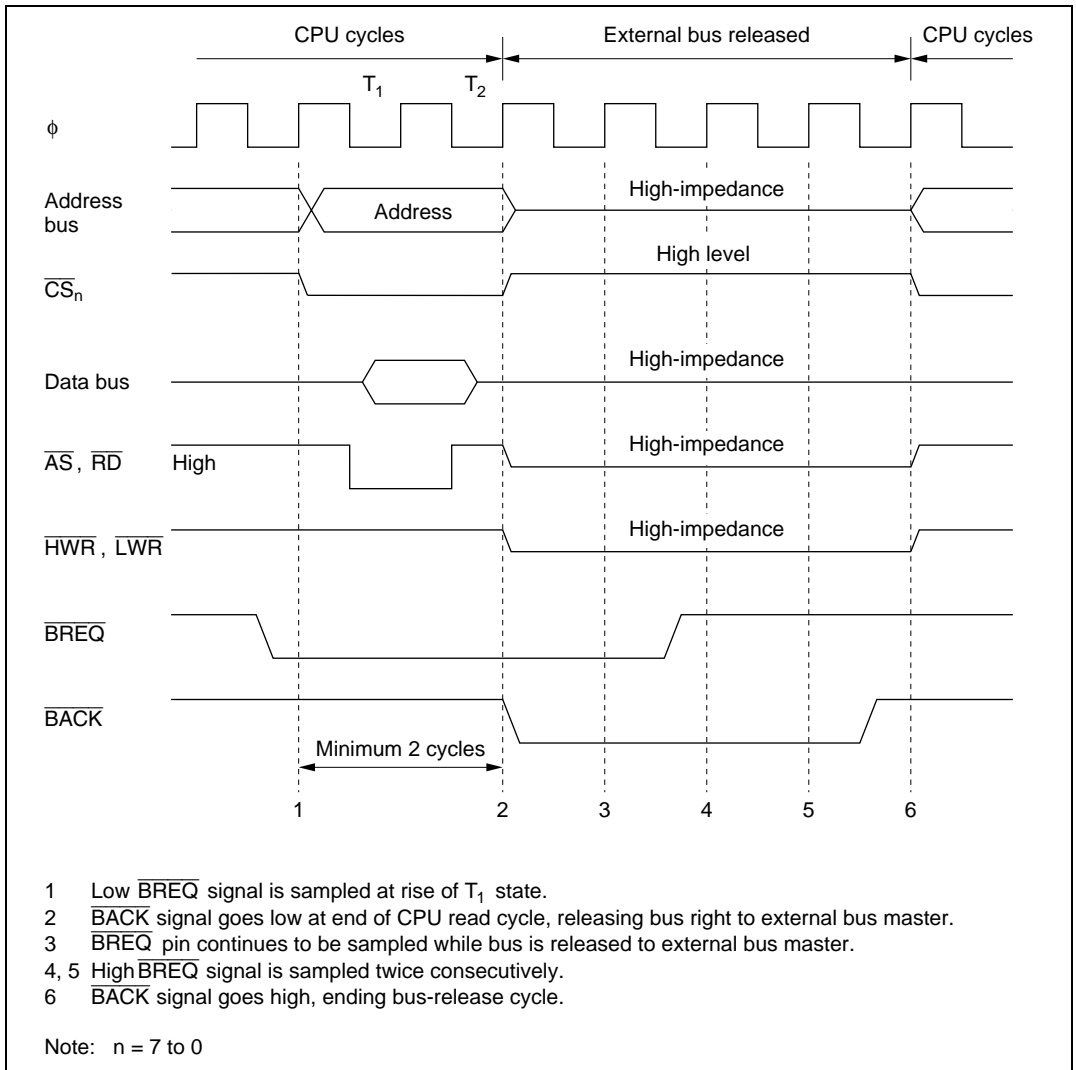

Figure 6.19 External-Bus-Released State (Two-State-Access Area, During Read Cycle)

6.4 Usage Notes

6.4.1 Connection to Dynamic RAM and Pseudo-Static RAM

A different bus control signal timing applies when dynamic RAM or pseudo-static RAM is connected to area 3. For details see section 7, Refresh Controller.

6.4.2 Register Write Timing

ABWCR, ASTCR, and WCER Write Timing

Data written to ABWCR, ASTCR, or WCER takes effect starting from the next bus cycle. Figure 6.20 shows the timing when an instruction fetched from area 0 changes area 0 from three-state access to two-state access.

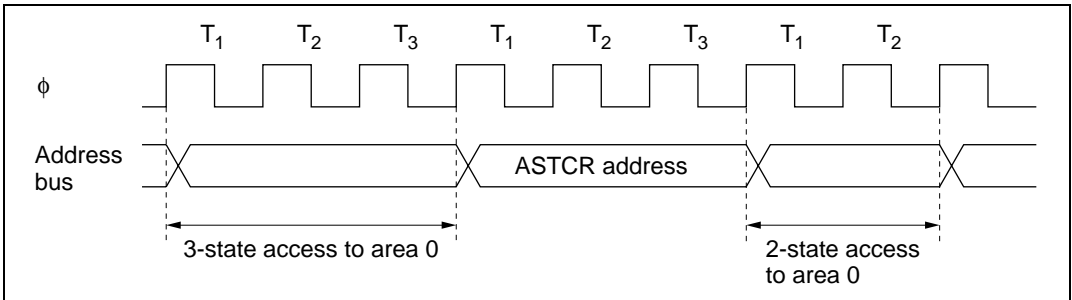

Figure 6.20 ASTCR Write Timing

DDR Write Timing

Data written to a data direction register (DDR) to change a \overline{CS}_n pin from \overline{CS}_n output to generic input, or vice versa, takes effect starting from the T_3 state of the DDR write cycle. Figure 6.21 shows the timing when the \overline{CS}_1 pin is changed from generic input to \overline{CS}_1 output.

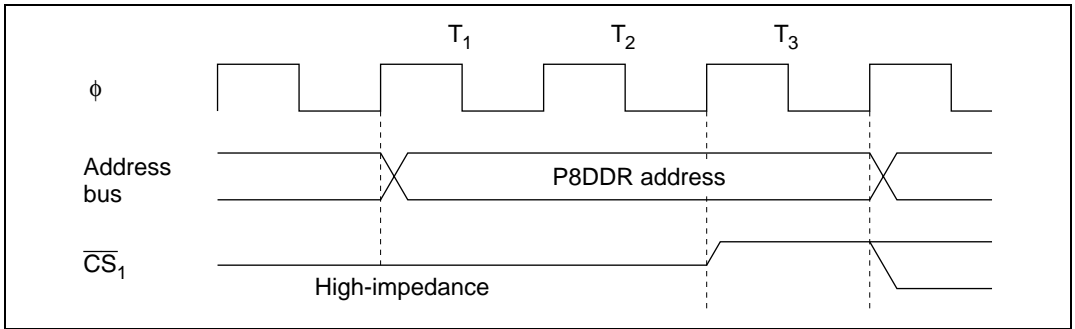

Figure 6.21 DDR Write Timing

BRCR Write Timing

Data written to switch between A_{23} , A_{22} , or A_{21} output and generic input or output takes effect starting from the T_3 state of the BRCR write cycle. Figure 6.22 shows the timing when a pin is changed from generic input to A_{23} , A_{22} , or A_{21} output.

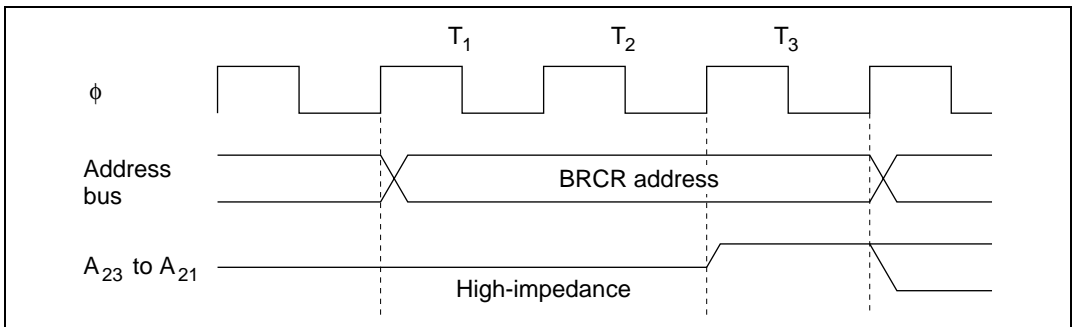

Figure 6.22 BRCR Write Timing

6.4.3 $\overline{\text{BREQ}}$ Input Timing

After driving the $\overline{\text{BREQ}}$ pin low, hold it low until $\overline{\text{BACK}}$ goes low. If $\overline{\text{BREQ}}$ returns to the high level before $\overline{\text{BACK}}$ goes low, the bus arbiter may operate incorrectly.

To terminate the external-bus-released state, hold the $\overline{\text{BREQ}}$ signal high for at least three states. If $\overline{\text{BREQ}}$ is high for too short an interval, the bus arbiter may operate incorrectly.

6.4.4 Transition To Software Standby Mode

If contention occurs between a transition to software standby mode and a bus request from an external bus master, the bus may be released for one state just before the transition to software standby mode (see figure 6.23). When using software standby mode, clear the BRLE bit to 0 in BRCR before executing the SLEEP instruction.

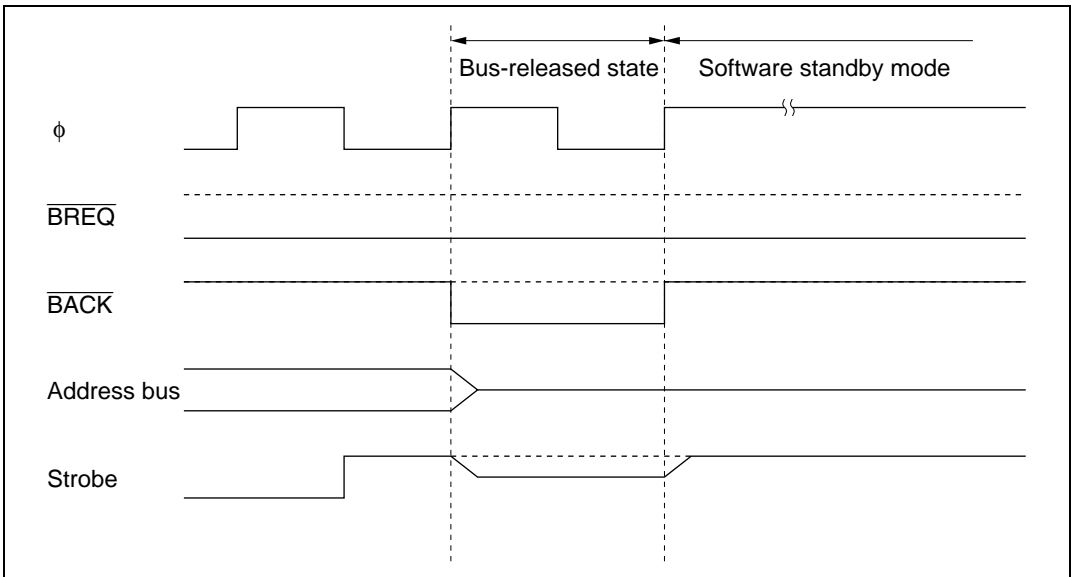

Figure 6.23 Contention between Bus-Released State and Software Standby Mode

Section 7 Refresh Controller

7.1 Overview

The H8/3048B Group has an on-chip refresh controller that enables direct connection of 16-bit-wide DRAM or pseudo-static RAM (PSRAM).

DRAM or pseudo-static RAM can be directly connected to area 3 of the external address space.

A maximum 128 kbytes can be connected in modes 1, 2, and 5 (1-Mbyte modes). A maximum 2 Mbytes can be connected in modes 3, 4, and 6 (16-Mbyte modes).

Systems that do not need to refresh DRAM or pseudo-static RAM can use the refresh controller as an 8-bit interval timer.

When the refresh controller is not used, it can be independently halted to conserve power. For details see section 20.6, Module Standby Function.

7.1.1 Features

The refresh controller can be used for one of three functions: DRAM refresh control, pseudo-static RAM refresh control, or 8-bit interval timing. Features of the refresh controller are listed below.

Features as a DRAM Refresh Controller:

- Enables direct connection of 16-bit-wide DRAM
- Selection of $2\overline{\text{CAS}}$ or $2\overline{\text{WE}}$ mode
- Selection of 8-bit or 9-bit column address multiplexing for DRAM address input

Examples:

- 1-Mbit DRAM: 8-bit row address \times 8-bit column address
- 4-Mbit DRAM: 9-bit row address \times 9-bit column address
- 4-Mbit DRAM: 10-bit row address \times 8-bit column address
- $\overline{\text{CAS}}$ -before- $\overline{\text{RAS}}$ refresh control
- Software-selectable refresh interval
- Software-selectable self-refresh mode
- Wait states can be inserted

Features as a Pseudo-Static RAM Refresh Controller:

- $\overline{\text{RFSH}}$ signal output for refresh control
- Software-selectable refresh interval
- Software-selectable self-refresh mode
- Wait states can be inserted

Features as an Interval Timer:

- Refresh timer counter (RTCNT) can be used as an 8-bit up-counter
- Selection of seven counter clock sources: $\phi/2$, $\phi/8$, $\phi/32$, $\phi/128$, $\phi/512$, $\phi/2048$, $\phi/4096$
- Interrupts can be generated by compare match between RTCNT and the refresh time constant register (RTCOR)

7.1.2 Block Diagram

Figure 7.1 shows a block diagram of the refresh controller.

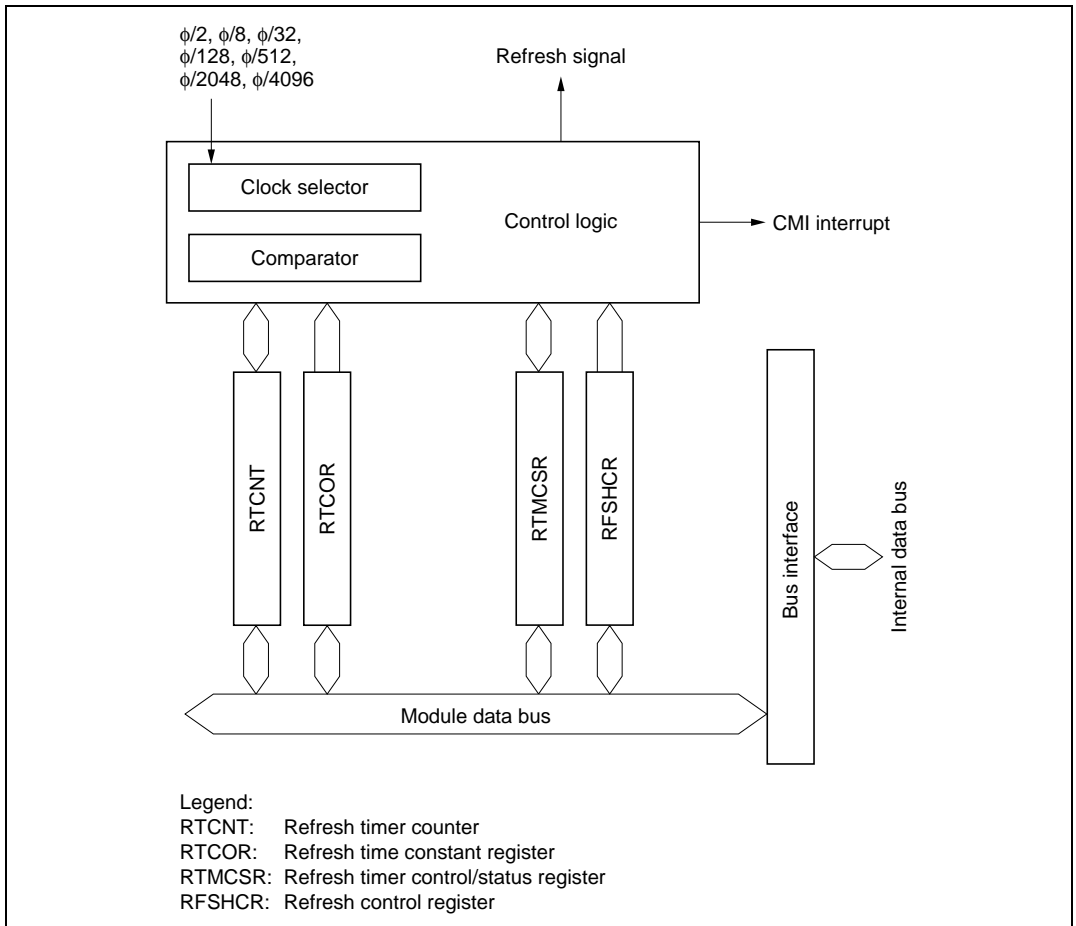

Figure 7.1 Block Diagram of Refresh Controller

7.1.3 Input/Output Pins

Table 7.1 summarizes the refresh controller's input/output pins.

Table 7.1 Refresh Controller Pins

Pin	Signal		I/O	Function
	Name	Abbr.		
$\overline{\text{RFSH}}$	Refresh	RFSH	Output	Goes low during refresh cycles; used to refresh DRAM and PSRAM
$\overline{\text{HWR}}$	Upper write/upper column address strobe	UW/UCAS	Output	Connects to the $\overline{\text{UW}}$ pin of $2\overline{\text{WE}}$ DRAM or $\overline{\text{UCAS}}$ pin of $2\overline{\text{CAS}}$ DRAM
$\overline{\text{LWR}}$	Lower write/lower column address strobe	LW/LCAS	Output	Connects to the $\overline{\text{LW}}$ pin of $2\overline{\text{WE}}$ DRAM or $\overline{\text{LCAS}}$ pin of $2\overline{\text{CAS}}$ DRAM
$\overline{\text{RD}}$	Column address strobe/write enable	CAS/WE	Output	Connects to the $\overline{\text{CAS}}$ pin of $2\overline{\text{WE}}$ DRAM or $\overline{\text{WE}}$ pin of $2\overline{\text{CAS}}$ DRAM
$\overline{\text{CS}}_3$	Row address strobe	RAS	Output	Connects to the $\overline{\text{RAS}}$ pin of DRAM

7.1.4 Register Configuration

Table 7.2 summarizes the refresh controller's registers.

Table 7.2 Refresh Controller Registers

Address*	Name	Abbreviation	R/W	Initial Value
H'FFAC	Refresh control register	RFSHCR	R/W	H'02
H'FFAD	Refresh timer control/status register	RTMCSR	R/W	H'07
H'FFAE	Refresh timer counter	RTCNT	R/W	H'00
H'FFAF	Refresh time constant register	RTCOR	R/W	H'FF

Note: * Lower 16 bits of the address.

7.2 Register Descriptions

7.2.1 Refresh Control Register (RFSHCR)

RFSHCR is an 8-bit readable/writable register that selects the operating mode of the refresh controller.

Bit	7	6	5	4	3	2	1	0
	SRFMD	PSRAME	DRAME	CAS/WE	M9/M8	RFSHE	—	RCYCE
Initial value	0	0	0	0	0	0	1	0
Read/Write	R/W	R/W	R/W	R/W	R/W	R/W	—	R/W

Self-refresh mode
Selects self-refresh mode

PSRAM enable and DRAM enable
These bits enable or disable connection of pseudo-static RAM and DRAM

Strobe mode select
Selects $2\overline{CAS}$ or $2\overline{WE}$ strobing of DRAM

Address multiplex mode select
Selects the number of column address bits

Refresh pin enable
Enables refresh signal output from the refresh pin

Reserved bit

Refresh cycle enable
Enables or disables insertion of refresh cycles

RFSHCR is initialized to H'02 by a reset and in hardware standby mode.

Bit 7—Self-Refresh Mode (SRFMD): Specifies DRAM or pseudo-static RAM self-refresh during software standby mode. When PSRAME = 1 and DRAME = 0, after the SRFMD bit is set to 1, pseudo-static RAM can be self-refreshed when the H8/3048B Group enters software standby mode. When PSRAME = 0 and DRAME = 1, after the SRFMD bit is set to 1, DRAM can be self-refreshed when the H8/3048B Group enters software standby mode. In either case, the normal access state resumes on exit from software standby mode.

Bit 7: SRFMD	Description
0	DRAM or PSRAM self-refresh is disabled in software standby mode (Initial value)
1	DRAM or PSRAM self-refresh is enabled in software standby mode

Bit 6—PSRAM Enable (PSRAME) and

Bit 5—DRAM Enable (DRAME): These bits enable or disable connection of pseudo-static RAM and DRAM to area 3 of the external address space.

When DRAM or pseudo-static RAM is connected, the bus cycle and refresh cycle of area 3 consist of three states, regardless of the setting in the access state control register (ASTCR). If AST3 = 0 in ASTCR, wait states cannot be inserted.

When the PSRAME or DRAME bit is set to 1, bits 0, 2, 3, and 4 in RFSHCR and registers RTMCSR, RTCNT, and RTCOR are write-disabled, except that the CMF flag in RTMCSR can be cleared by writing 0.

Bit 6: PSRAME	Bit 5: DRAME	Description
0	0	Can be used as an interval timer (Initial value) (DRAM and PSRAM cannot be directly connected)
	1	DRAM can be directly connected
1	0	PSRAM can be directly connected
	1	Illegal setting

Bit 4—Strobe Mode Select (CAS/ \overline{WE}): Selects $2\overline{CAS}$ or $2\overline{WE}$ mode. The setting of this bit is valid when PSRAME = 0 and DRAME = 1. This bit is write-disabled when the PSRAME or DRAME bit is set to 1.

Bit 4: CAS/ \overline{WE}	Description
0	$2\overline{WE}$ mode (Initial value)
1	$2\overline{CAS}$ mode

Bit 3—Address Multiplex Mode Select ($M9/\overline{M8}$): Selects 8-bit or 9-bit column addressing.

The setting of this bit is valid when $PSRAM = 0$ and $DRAME = 1$. This bit is write-disabled when the $PSRAM$ or $DRAME$ bit is set to 1.

Bit 3: $M9/\overline{M8}$	Description	
0	8-bit column address mode	(Initial value)
1	9-bit column address mode	

Bit 2—Refresh Pin Enable (RFSHE): Enables or disables refresh signal output from the \overline{RFSH} pin. This bit is write-disabled when the $PSRAM$ or $DRAME$ bit is set to 1.

Bit 2: RFSHE	Description	
0	Refresh signal output at the \overline{RFSH} pin is disabled (the \overline{RFSH} pin can be used as a generic input/output port)	(Initial value)
1	Refresh signal output at the \overline{RFSH} pin is enabled	

Bit 1—Reserved: Read-only bit, always read as 1.

Bit 0—Refresh Cycle Enable (RCYCE): Enables or disables insertion of refresh cycles.

The setting of this bit is valid when $PSRAM = 1$ or $DRAME = 1$. When $PSRAM = 0$ and $DRAME = 0$, refresh cycles are not inserted regardless of the setting of this bit.

Bit 0: RCYCE	Description	
0	Refresh cycles are disabled	(Initial value)
1	Refresh cycles are enabled for area 3	

7.2.2 Refresh Timer Control/Status Register (RTMCSR)

RTMCSR is an 8-bit readable/writable register that selects the clock source for RTCNT. It also enables or disables interrupt requests when the refresh controller is used as an interval timer.

Bit	7	6	5	4	3	2	1	0
	CMF	CMIE	CKS2	CKS1	CKS0	—	—	—
Initial value	0	0	0	0	0	1	1	1
Read/Write	R/(W)*	R/W	R/W	R/W	R/W	—	—	—

Clock select 2 to 0
 These bits select an internal clock source for input to RTCNT

Reserved bits

Compare match interrupt enable
 Enables or disables the CMI interrupt requested by CMF

Compare match flag
 Status flag indicating that RTCNT has matched RTCOR

Note: * Only 0 can be written, to clear the flag.

Bits 7 and 6 are initialized by a reset and in standby mode. Bits 5 to 3 are initialized by a reset and in hardware standby mode, but retain their previous values on transition to software standby mode.

Bit 7—Compare Match Flag (CMF): This status flag indicates that the RTCNT and RTCOR values have matched.

Bit 7: CMF	Description
0	[Clearing condition] Cleared by reading CMF when CMF = 1, then writing 0 in CMF
1	[Setting condition] When RTCNT = RTCOR

Bit 6—Compare Match Interrupt Enable (CMIE): Enables or disables the CMI interrupt requested when the CMF flag is set to 1 in RTMCSR. The CMIE bit is always cleared to 0 when PSRAME = 1 or DRAME = 1.

Bit 6: CMIE	Description
0	The CMI interrupt requested by CMF is disabled (Initial value)
1	The CMI interrupt requested by CMF is enabled

Bits 5 to 3—Clock Select 2 to 0 (CKS2 to CKS0): These bits select an internal clock source for input to RTCNT. When used for refresh control, the refresh controller outputs a refresh request at periodic intervals determined by compare match between RTCNT and RTCOR. When used as an interval timer, the refresh controller generates CMI interrupts at periodic intervals determined by compare match. These bits are write-disabled when the PSRAME bit or DRAME bit is set to 1.

Bit 5: CKS2	Bit 4: CKS1	Bit 3: CKS0	Description
0	0	0	Clock input is disabled (Initial value)
		1	$\phi/2$ clock source
	1	0	$\phi/8$ clock source
1	0	1	$\phi/32$ clock source
		0	$\phi/128$ clock source
	1	0	$\phi/512$ clock source
		1	$\phi/2048$ clock source
		1	$\phi/4096$ clock source

Bits 2 to 0—Reserved: Read-only bits, always read as 1.

7.2.3 Refresh Timer Counter (RTCNT)

RTCNT is an 8-bit readable/writable up-counter.

Bit	7	6	5	4	3	2	1	0
Initial value	0	0	0	0	0	0	0	0
Read/Write	R/W	R/W	R/W	R/W	R/W	R/W	R/W	R/W

RTCNT is an up-counter that is incremented by an internal clock selected by bits CKS2 to CKS0 in RTMCSR. When RTCNT matches RTCOR (compare match), the CMF flag is set to 1 and RTCNT is cleared to H'00.

RTCNT is write-disabled when the PSRAME bit or DRAME bit is set to 1. RTCNT is initialized to H'00 by a reset and in standby mode.

7.2.4 Refresh Time Constant Register (RTCOR)

RTCOR is an 8-bit readable/writable register that determines the interval at which RTCNT is compare matched.

Bit	7	6	5	4	3	2	1	0
Initial value	1	1	1	1	1	1	1	1
Read/Write	R/W	R/W	R/W	R/W	R/W	R/W	R/W	R/W

RTCOR and RTCNT are constantly compared. When their values match, the CMF flag is set to 1 in RTMCSR, and RTCNT is simultaneously cleared to H'00.

RTCOR is write-disabled when the PSRAME bit or DRAME bit is set to 1. RTCOR is initialized to H'FF by a reset and in hardware standby mode. In software standby mode it retains its previous value.

7.3 Operation

7.3.1 Overview

One of three functions can be selected for the H8/3048B Group refresh controller: interfacing to DRAM connected to area 3, interfacing to pseudo-static RAM connected to area 3, or interval timing. Table 7.3 summarizes the register settings when these three functions are used.

Table 7.3 Refresh Controller Settings

Register Settings		Usage		
		DRAM Interface	PSRAM Interface	Interval Timer
RFSHCR	SRFMD	Selects self-refresh mode	Selects self-refresh mode	Cleared to 0
	PSRAME	Cleared to 0	Set to 1	Cleared to 0
	DRAME	Set to 1	Cleared to 0	Cleared to 0
	CAS/ \overline{WE}	Selects 2CAS or 2 \overline{WE} mode	—	—
	M9/ $\overline{M8}$	Selects column addressing mode	—	—
	RFSHE	Selects \overline{RFSH} signal output	Selects \overline{RFSH} signal output	Cleared to 0
	RCYCE	Selects insertion of refresh cycles	Selects insertion of refresh cycles	—
RTCOR		Refresh interval setting	Refresh interval setting	Interrupt interval setting
RTMCSR	CKS2 to CKS0			
	CMF	Set to 1 when RTCNT = RTCOR	Set to 1 when RTCNT = RTCOR	Set to 1 when RTCNT = RTCOR
	CMIE	Cleared to 0	Cleared to 0	Enables or disables interrupt requests
P8DDR	P8 _{DDR}	Set to 1 (\overline{CS}_3 output)	Set to 1 (\overline{CS}_3 output)	Set to 0 or 1
ABWCR	ABW3	Cleared to 0	—	—

DRAM Interface

To set up area 3 for connection to 16-bit-wide DRAM, initialize RTCOR, RTMCSR, and RFSHCR in that order, clearing bit PSRAME to 0 and setting bit DRAME to 1. Set bit P8₁DDR to 1 in the port 8 data direction register (P8DDR) to enable \overline{CS}_3 output. In ABWCR, make area 3 a 16-bit-access area.

Pseudo-Static RAM Interface

To set up area 3 for connection to pseudo-static RAM, initialize RTCOR, RTMCSR, and RFSHCR in that order, setting bit PSRAME to 1 and clearing bit DRAME to 0. Set bit P8₁DDR to 1 in P8DDR to enable \overline{CS}_3 output.

Interval Timer

When PSRAME = 0 and DRAME = 0, the refresh controller operates as an interval timer. After setting RTCOR, select an input clock in RTMCSR and set the CMIE bit to 1. CMI interrupts will be requested at compare match intervals determined by RTCOR and bits CKS2 to CKS0 in RTMCSR.

When setting RTCOR, RTMCSR, and RFSHCR, make sure that PSRAME = 0 and DRAME = 0. Writing is disabled when either of these bits is set to 1.

7.3.2 DRAM Refresh Control

Refresh Request Interval and Refresh Cycle Execution

The refresh request interval is determined by the settings of RTCOR and bits CKS2 to CKS0 in RTMCSR. Figure 7.2 illustrates the refresh request interval.

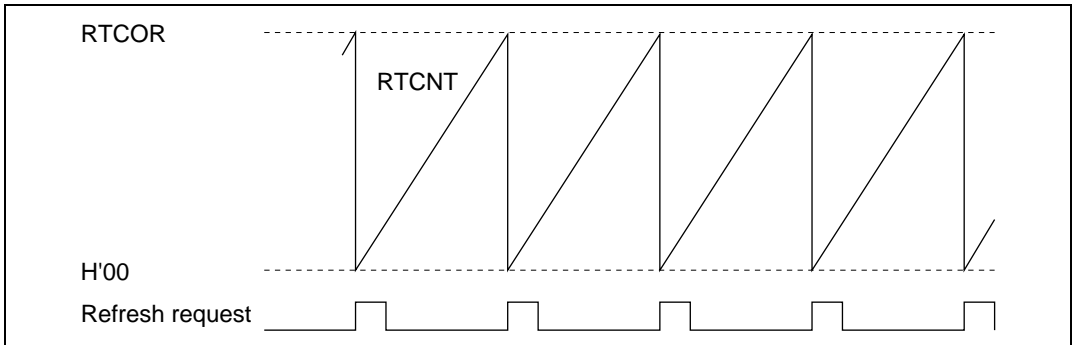

Figure 7.2 Refresh Request Interval (RCYCE = 1)

Refresh requests are generated at regular intervals as shown in figure 7.2, but the refresh cycle is not actually executed until the refresh controller gets the bus right.

Table 7.4 summarizes the relationship among area 3 settings, DRAM read/write cycles, and refresh cycles.

Table 7.4 Area 3 Settings, DRAM Access Cycles, and Refresh Cycles

Area 3 Settings	Read/Write Cycle by CPU or DMAC	Refresh Cycle
2-state-access area (AST3 = 0)	<ul style="list-style-type: none"> • 3 states • Wait states cannot be inserted 	<ul style="list-style-type: none"> • 3 states • Wait states cannot be inserted
3-state-access area (AST3 = 1)	<ul style="list-style-type: none"> • 3 states • Wait states can be inserted 	<ul style="list-style-type: none"> • 3 states • Wait states can be inserted

To insert refresh cycles, set the RCYCE bit to 1 in RFSHCR. Figure 7.3 shows the state transitions for execution of refresh cycles.

When the first refresh request occurs after exit from the reset state or standby mode, the refresh controller does not execute a refresh cycle, but goes into the refresh request pending state. Note this point when using a DRAM that requires a refresh cycle for initialization.

When a refresh request occurs in the refresh request pending state, the refresh controller acquires the bus right, then executes a refresh cycle. If another refresh request occurs during execution of the refresh cycle, it is ignored.

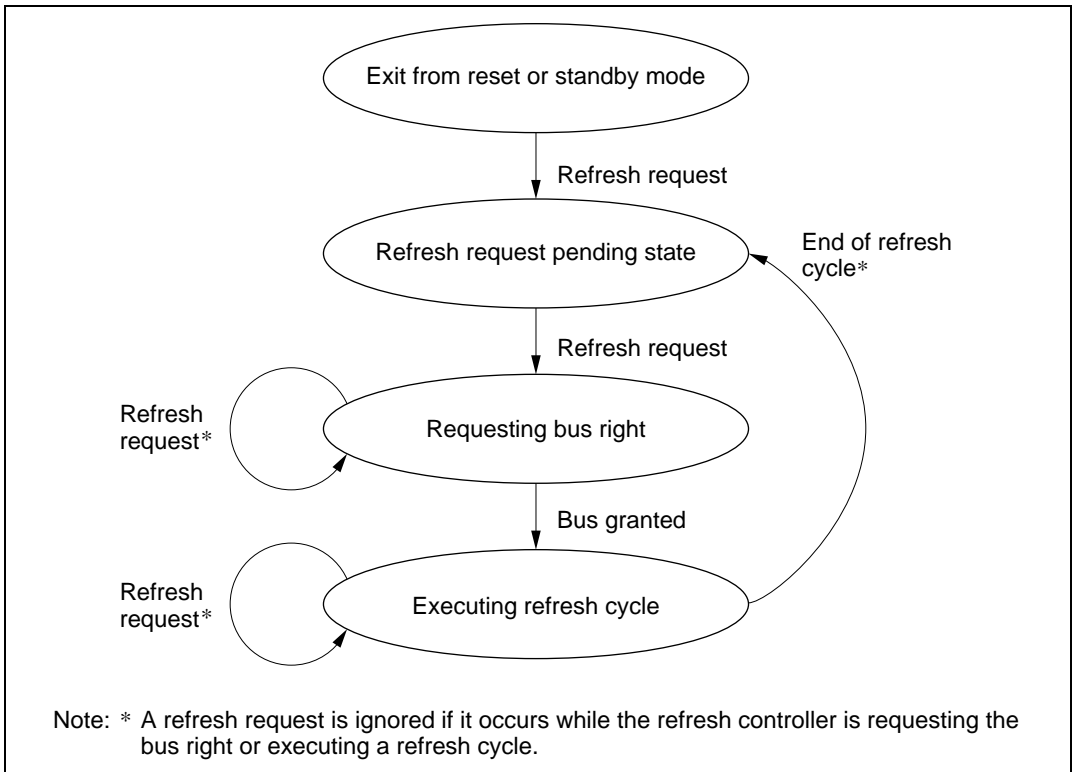

Figure 7.3 State Transitions for Refresh Cycle Execution

Address Multiplexing

Address multiplexing depends on the setting of the $M9/\overline{M8}$ bit in RFSHCR, as described in table 7.5. Figure 7.4 shows the address output timing. Address output is multiplexed only in area 3.

Table 7.5 Address Multiplexing

Address Pins	A_{23} to											
	A_{10}	A_9	A_8	A_7	A_6	A_5	A_4	A_3	A_2	A_1	A_0	
Address signals during row address output	A_{23} to A_{10}	A_9	A_8	A_7	A_6	A_5	A_4	A_3	A_2	A_1	A_0	
Address signals during column address output	$M9/\overline{M8} = 0$	A_{23} to A_{10}	A_9	A_9	A_{16}	A_{15}	A_{14}	A_{13}	A_{12}	A_{11}	A_{10}	A_0
	$M9/\overline{M8} = 1$	A_{23} to A_{10}	A_{18}	A_{17}	A_{16}	A_{15}	A_{14}	A_{13}	A_{12}	A_{11}	A_{10}	A_0

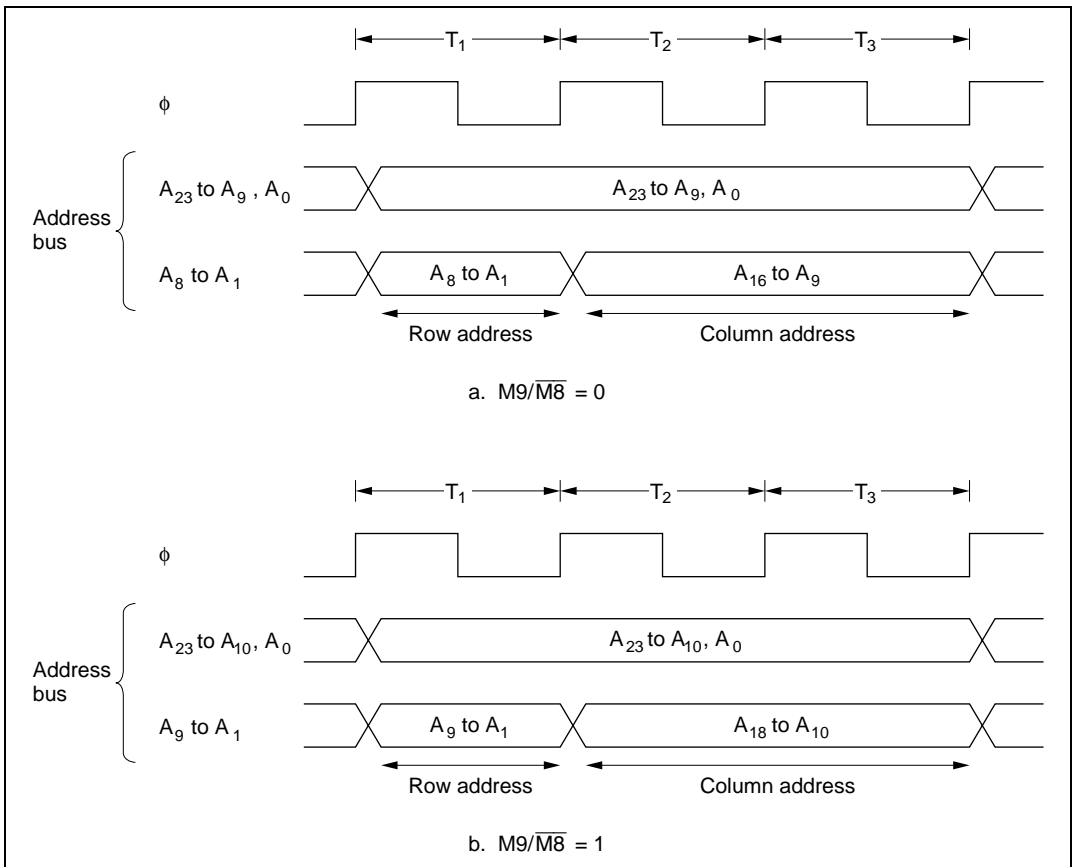

Figure 7.4 Multiplexed Address Output (Example without Wait States)

$2\overline{\text{CAS}}$ and $2\overline{\text{WE}}$ Modes

The $\text{CAS}/\overline{\text{WE}}$ bit in RFSHCR can select two control modes for 16-bit-wide DRAM: one using $\overline{\text{UCAS}}$ and $\overline{\text{LCAS}}$; the other using $\overline{\text{UW}}$ and $\overline{\text{LW}}$. These DRAM pins correspond to H8/3048B Group pins as shown in table 7.6.

Table 7.6 DRAM Pins and H8/3048B Group Pins

H8/3048B Group Pin	DRAM Pin	
	$\text{CAS}/\overline{\text{WE}} = 0$ ($2\overline{\text{WE}}$ Mode)	$\text{CAS}/\overline{\text{WE}} = 1$ ($2\overline{\text{CAS}}$ Mode)
$\overline{\text{HWR}}$	$\overline{\text{UW}}$	$\overline{\text{UCAS}}$
$\overline{\text{LWR}}$	$\overline{\text{LW}}$	$\overline{\text{LCAS}}$
$\overline{\text{RD}}$	$\overline{\text{CAS}}$	$\overline{\text{WE}}$
$\overline{\text{CS}}_3$	$\overline{\text{RAS}}$	$\overline{\text{RAS}}$

Figure 7.5 (1) shows the interface timing for $2\overline{\text{WE}}$ DRAM. Figure 7.5 (2) shows the interface timing for $2\overline{\text{CAS}}$ DRAM.

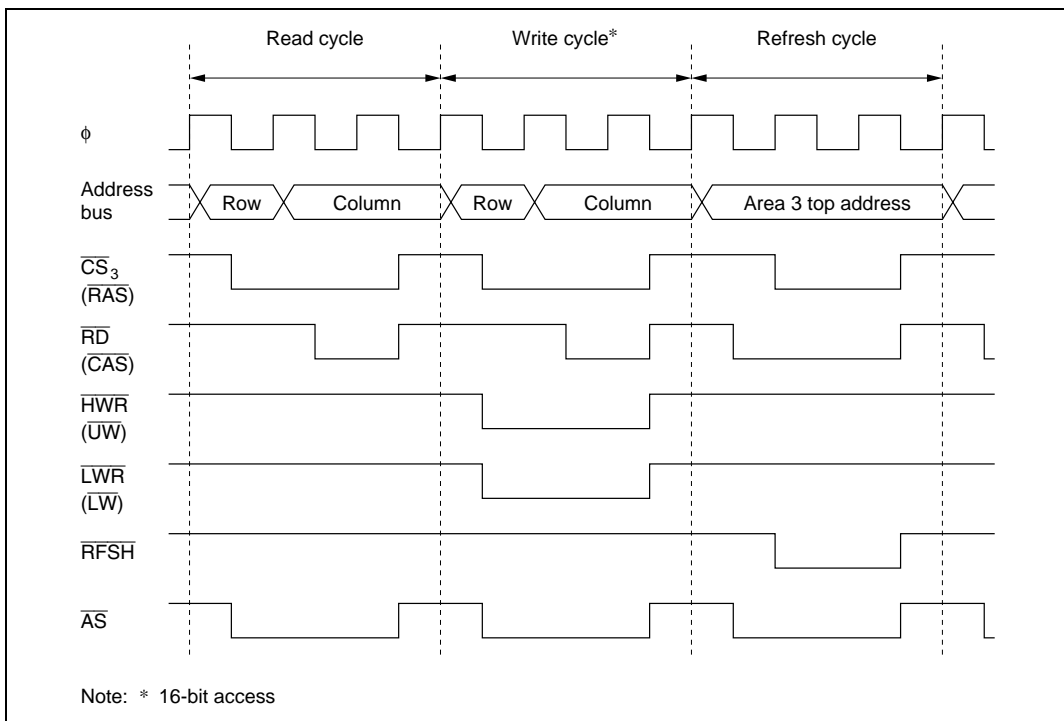

Figure 7.5(1) DRAM Control Signal Output Timing ($2\overline{\text{WE}}$ Mode)

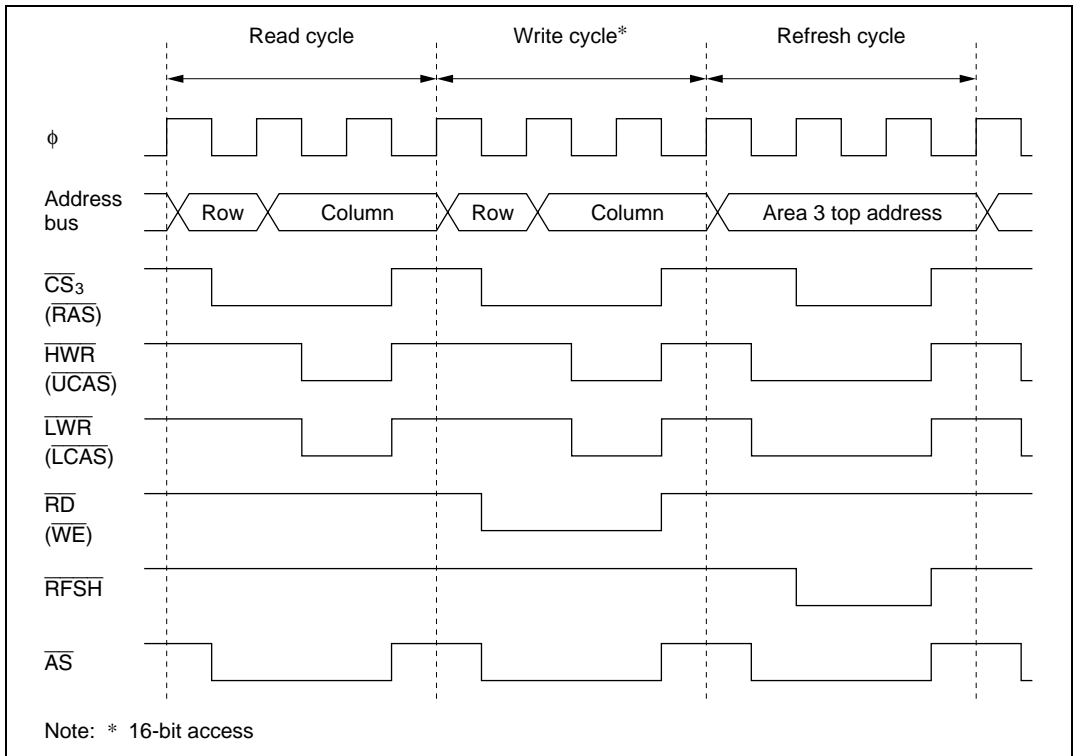

Figure 7.5(2) DRAM Control Signal Output Timing (2CAS Mode)

Refresh Cycle Priority Order

When there are simultaneous bus requests, the priority order is:

(High) External bus master > refresh controller > DMA controller > CPU (Low)

For details see section 6.3.7, Bus Arbiter Operation.

Wait State Insertion

When bit AST3 is set to 1 in ASTCR, bus controller settings can cause wait states to be inserted into bus cycles and refresh cycles. For details see section 6.3.5, Wait Modes.

Self-Refresh Mode

Some DRAM devices have a self-refresh function. After the SRFMD bit is set to 1 in RFSHCR, when a transition to software standby mode occurs, the $\overline{\text{CAS}}$ and $\overline{\text{RAS}}$ outputs go low in that order so that the DRAM self-refresh function can be used. On exit from software standby mode, the CAS and RAS outputs both go high.

Table 7.7 shows the pin states in software standby mode. Figure 7.6 shows the signal output timing.

Table 7.7 Pin States in Software Standby Mode (1) (PSRAME = 0, DRAME = 1)

Signal	Software Standby Mode			
	SRFMD = 0		SRFMD = 1 (self-refresh mode)	
	CAS/ $\overline{\text{WE}}$ = 0	CAS/ $\overline{\text{WE}}$ = 1	CAS/ $\overline{\text{WE}}$ = 0	CAS/ $\overline{\text{WE}}$ = 1
$\overline{\text{HWR}}$	High-impedance	High-impedance	High	Low
$\overline{\text{LWR}}$	High-impedance	High-impedance	High	Low
$\overline{\text{RD}}$	High-impedance	High-impedance	Low	High
$\overline{\text{CS}}_3$	High	High	Low	Low
$\overline{\text{RFSH}}$	High	High	Low	Low

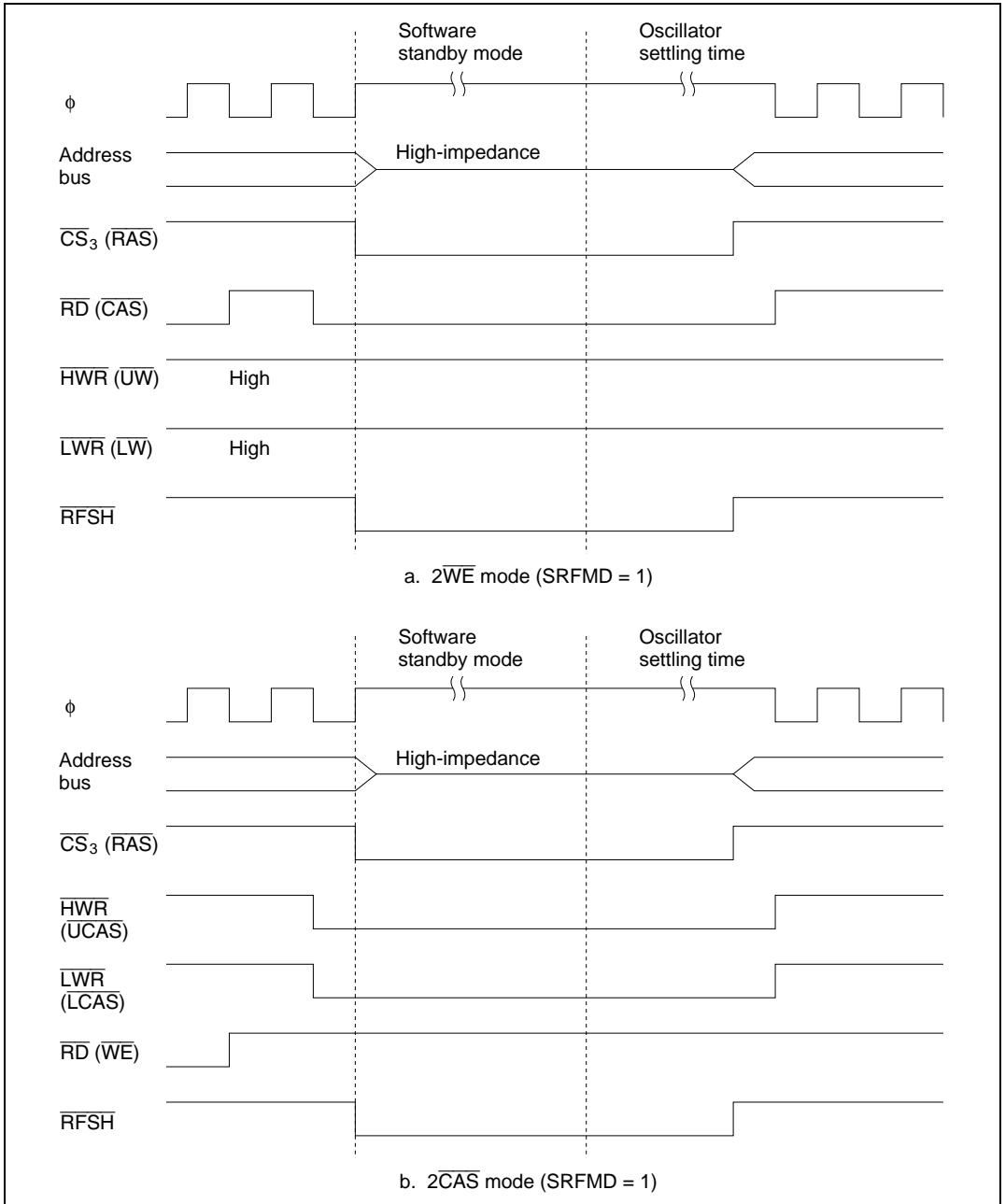

Figure 7.6 Signal Output Timing in Self-Refresh Mode (PSRAME = 0, DRAME = 1)

Operation in Power-Down State

The refresh controller operates in sleep mode. It does not operate in hardware standby mode. In software standby mode RTCNT is initialized, but RFSHCR, RTMCSR bits 5 to 3, and RTCOR retain their settings prior to the transition to software standby mode.

Example 1: Connection to $2\overline{WE}$ 1-Mbit DRAM (1-Mbyte Mode)

Figure 7.7 shows typical interconnections to a $2\overline{WE}$ 1-Mbit DRAM, and the corresponding address map. Figure 7.8 shows a setup procedure to be followed by a program for this example. After power-up the DRAM must be refreshed to initialize its internal state. Initialization takes a certain length of time, which can be measured by using an interrupt from another timer module, or by counting the number of times RTMCSR bit 7 (CMF) is set. Note that no refresh cycle is executed for the first refresh request after exit from the reset state or standby mode (the first time the CMF flag is set; see figure 7.3). When using this example, check the DRAM device characteristics carefully and use a procedure that fits them.

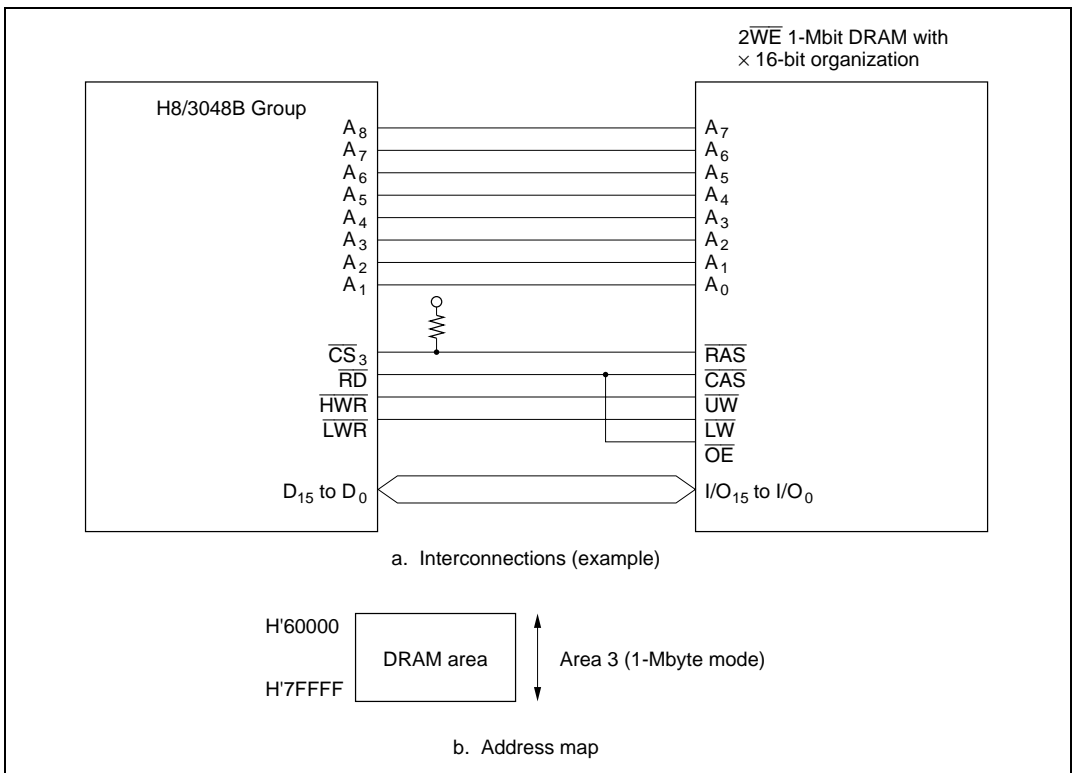

Figure 7.7 Interconnections and Address Map for $2\overline{WE}$ 1-Mbit DRAM (Example)

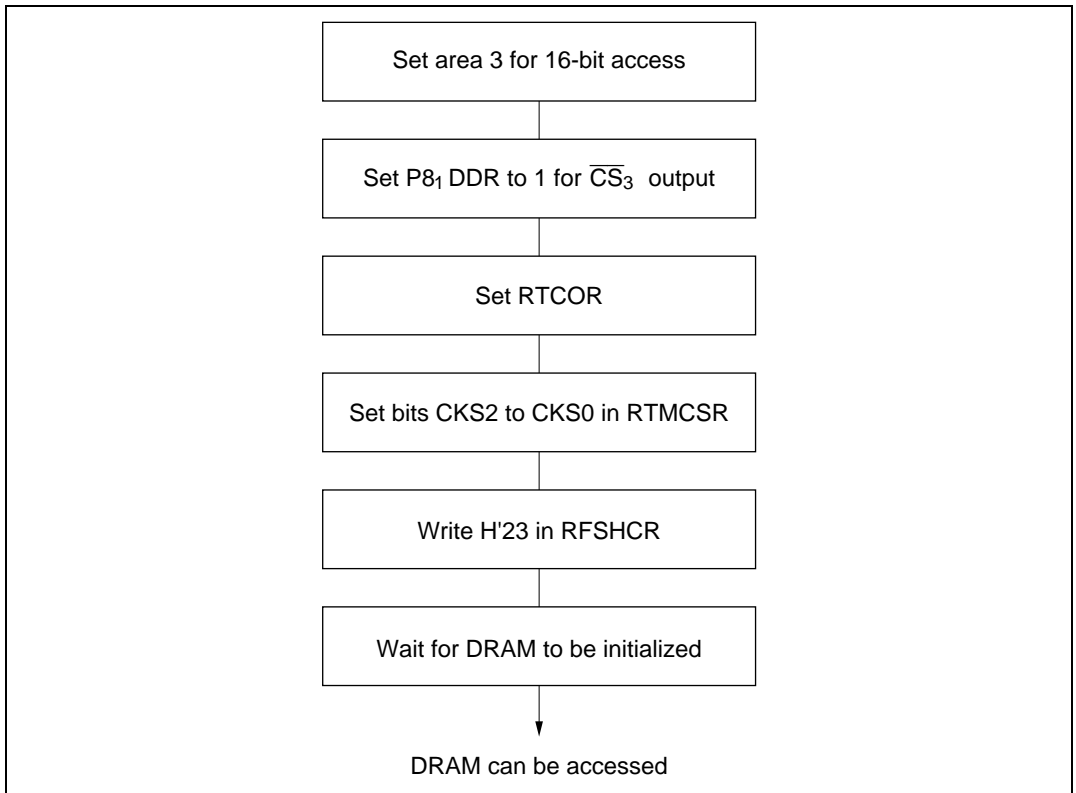

Figure 7.8 Setup Procedure for 2WE 1-Mbit DRAM (1-Mbyte Mode)

Example 2: Connection to $2\overline{WE}$ 4-Mbit DRAM (16-Mbyte Mode)

Figure 7.9 shows typical interconnections to a single $2\overline{WE}$ 4-Mbit DRAM, and the corresponding address map. Figure 7.10 shows a setup procedure to be followed by a program for this example.

The DRAM in this example has 10-bit row addresses and 8-bit column addresses. Its address area is H'600000 to H'67FFFF.

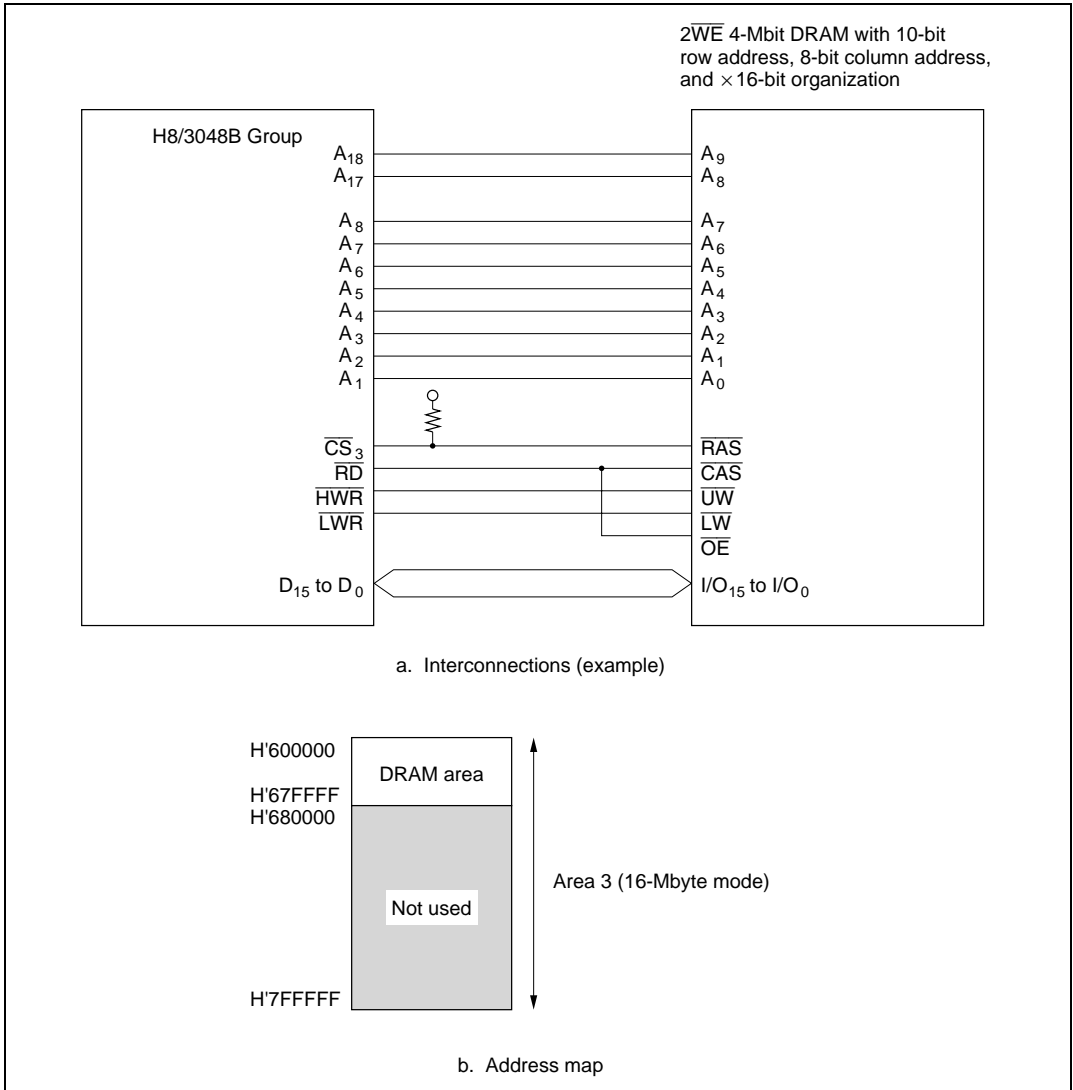

Figure 7.9 Interconnections and Address Map for $2\overline{WE}$ 4-Mbit DRAM (Example)

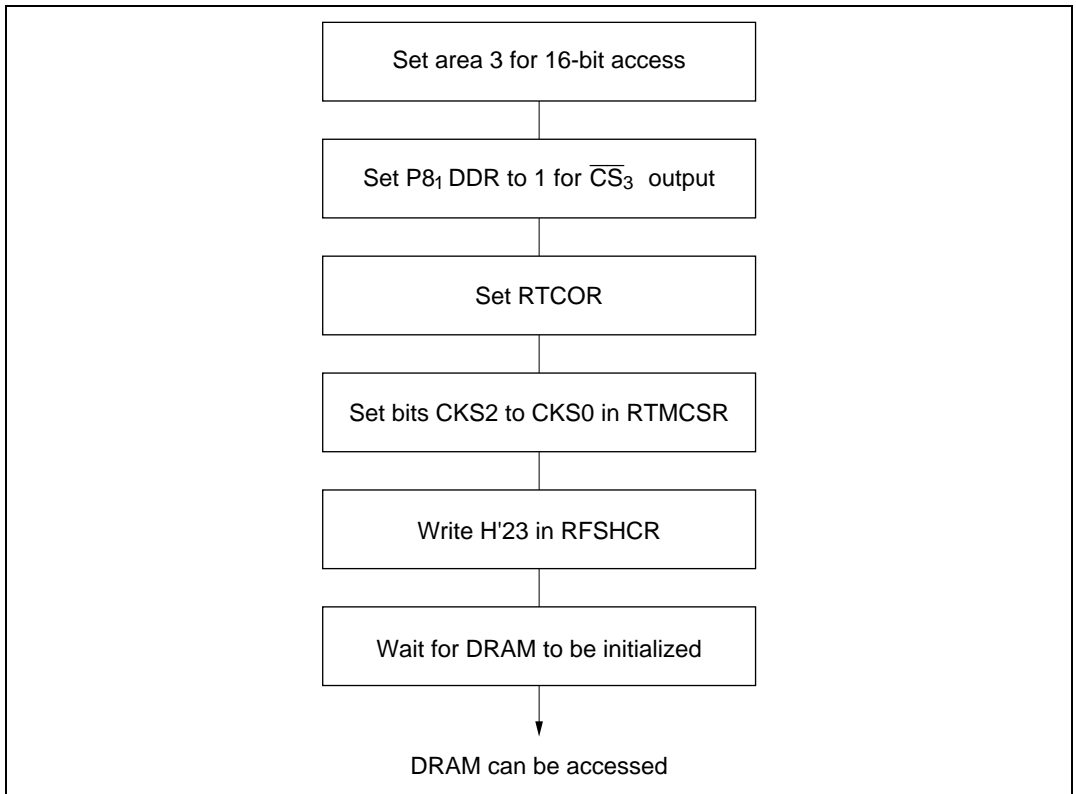

Figure 7.10 Setup Procedure for $2\overline{WE}$ 4-Mbit DRAM with 10-Bit Row Address and 8-Bit Column Address (16-Mbyte Mode)

Example 3: Connection to $2\overline{\text{CAS}}$ 4-Mbit DRAM (16-Mbyte Mode)

Figure 7.11 shows typical interconnections to a single $2\overline{\text{CAS}}$ 4-Mbit DRAM, and the corresponding address map.

Figure 7.12 shows a setup procedure to be followed by a program for this example.

The DRAM in this example has 9-bit row addresses and 9-bit column addresses. Its address area is H'600000 to H'67FFFF.

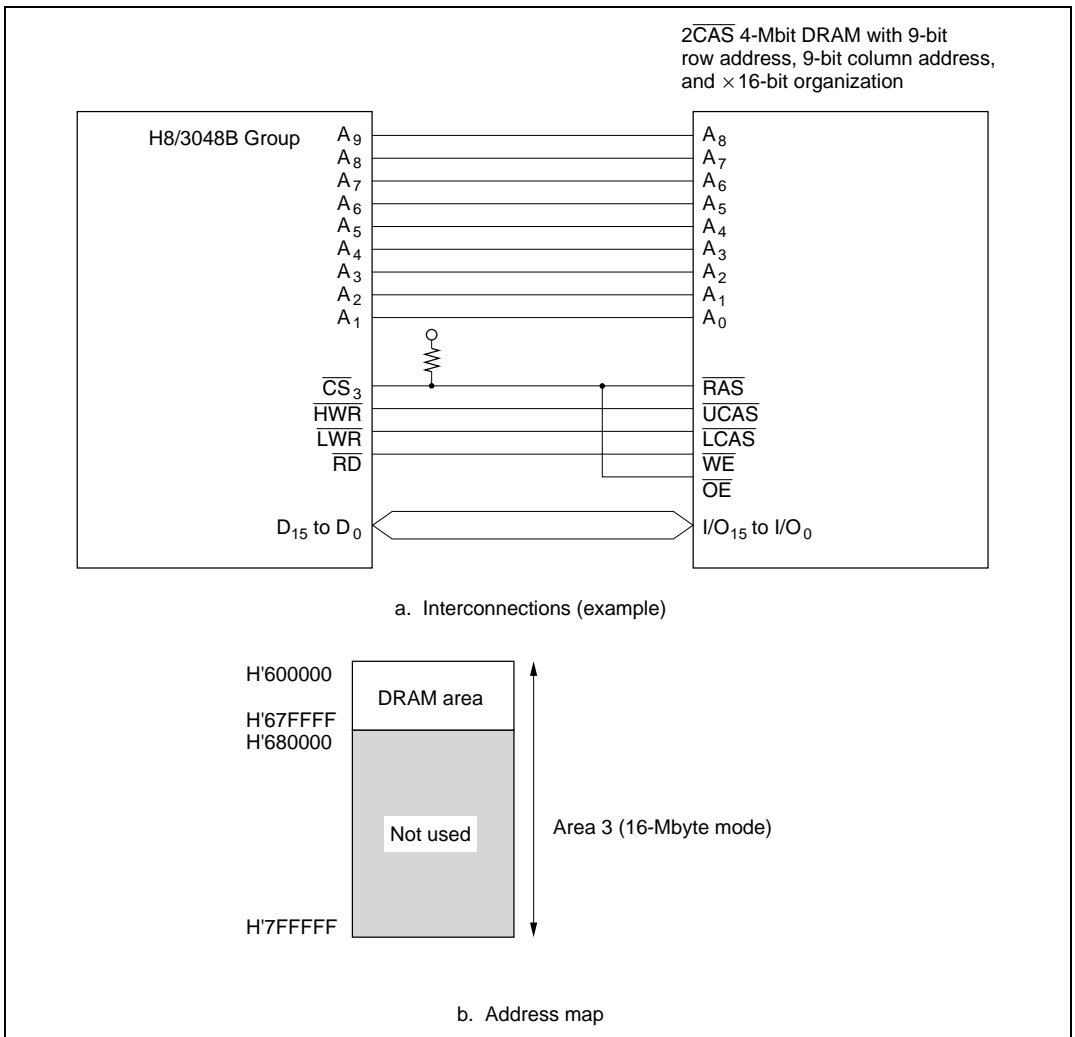

Figure 7.11 Interconnections and Address Map for $2\overline{\text{CAS}}$ 4-Mbit DRAM (Example)

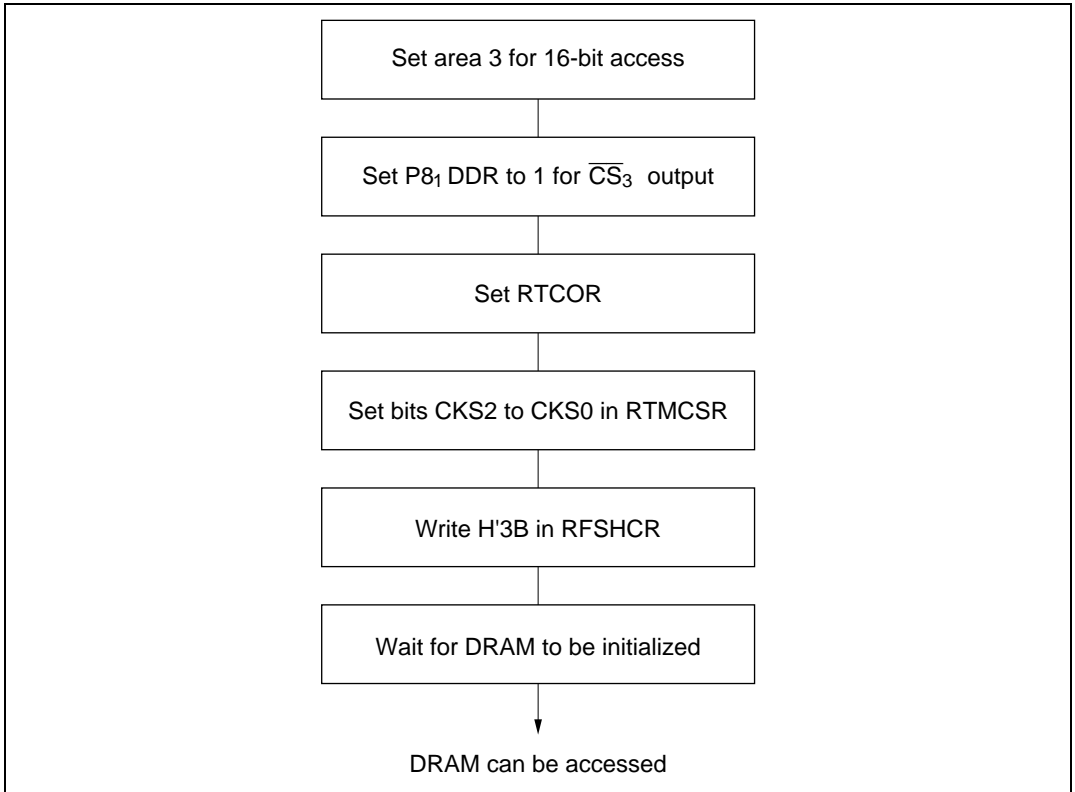

Figure 7.12 Setup Procedure for $2\overline{CAS}$ 4-Mbit DRAM with 9-Bit Row Address and 9-Bit Column Address (16-Mbyte Mode)

Example 4: Connection to Multiple 4-Mbit DRAM Chips (16-Mbyte Mode)

Figure 7.13 shows an example of interconnections to two $2\overline{CAS}$ 4-Mbit DRAM chips, and the corresponding address map. Up to four DRAM chips can be connected to area 3 by decoding upper address bits A_{19} and A_{20} .

Figure 7.14 shows a setup procedure to be followed by a program for this example. The DRAM in this example has 9-bit row addresses and 9-bit column addresses. Both chips must be refreshed simultaneously, so the \overline{RFSH} pin must be used.

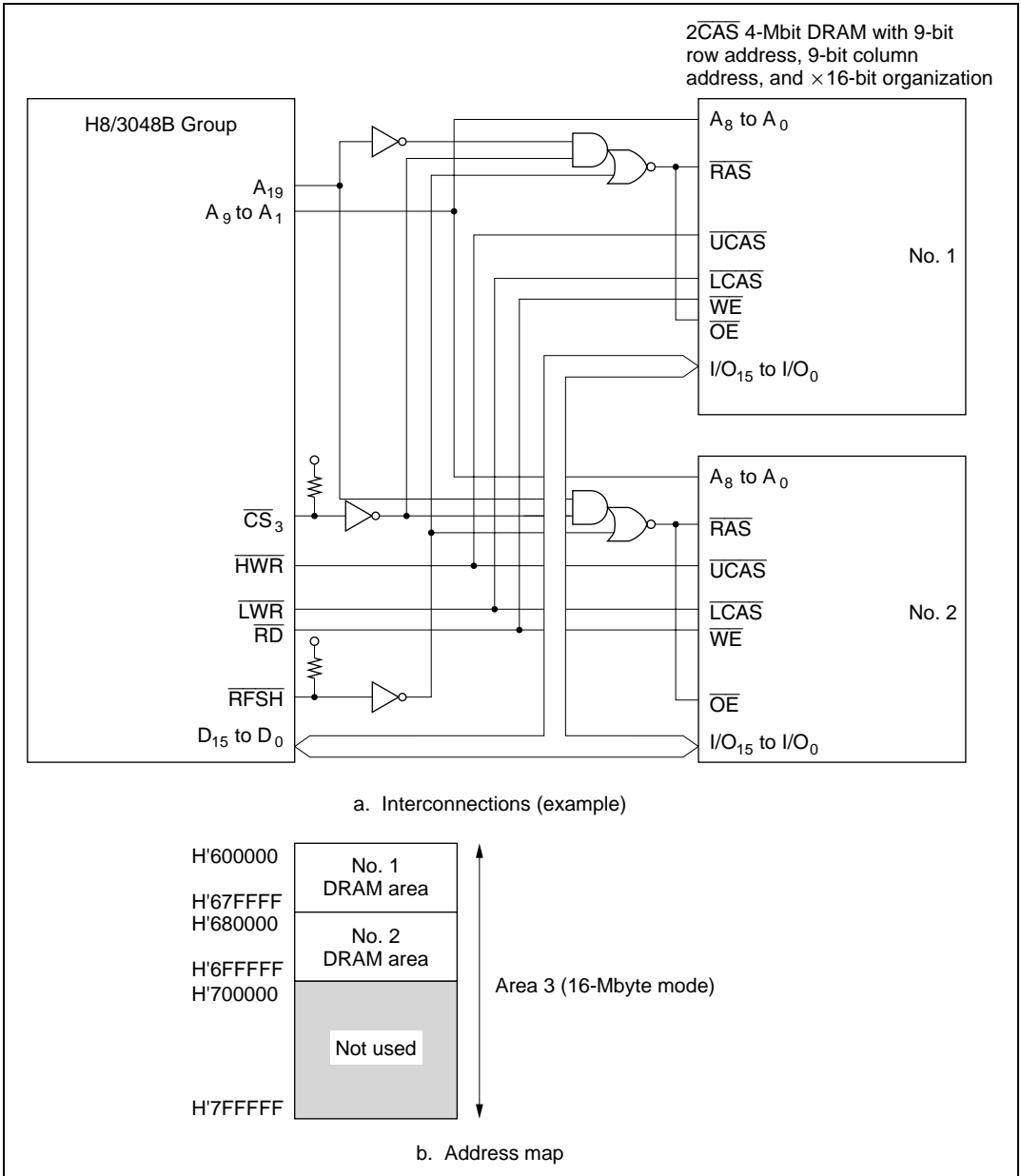

Figure 7.13 Interconnections and Address Map for Multiple 2CAS 4-Mbit DRAM Chips (Example)

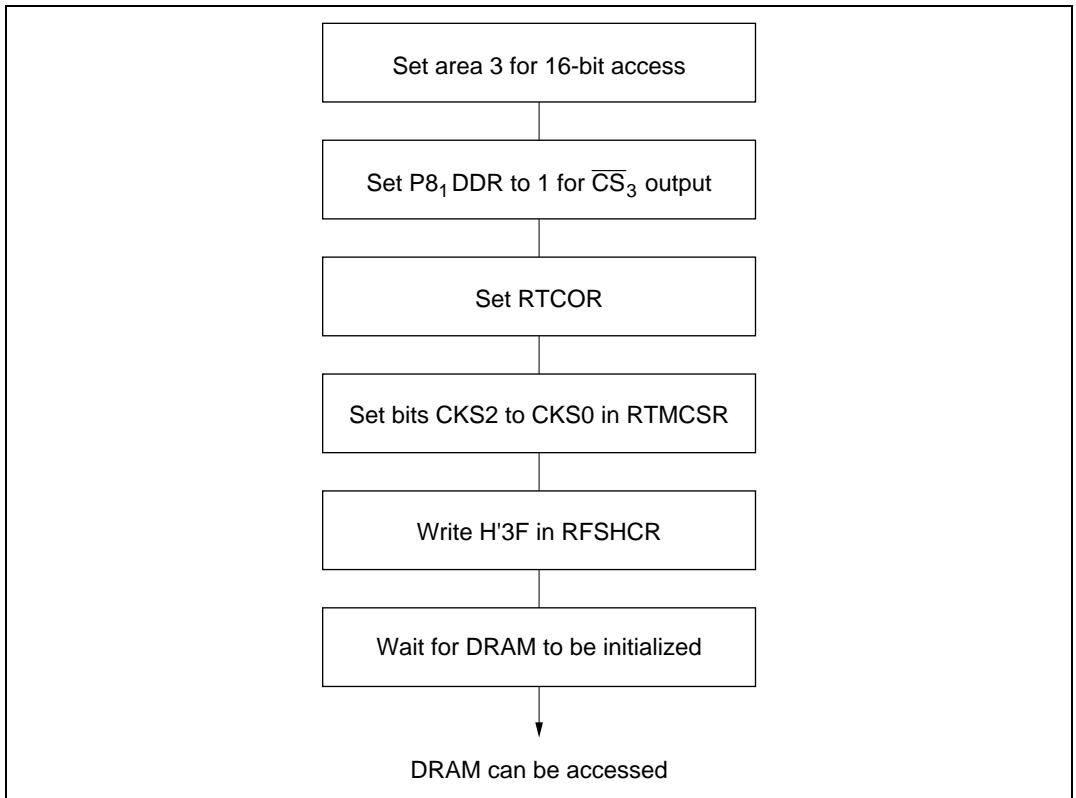

Figure 7.14 Setup Procedure for Multiple $\overline{2CAS}$ 4-Mbit DRAM Chips with 9-Bit Row Address and 9-Bit Column Address (16-Mbyte Mode)

7.3.3 Pseudo-Static RAM Refresh Control

Refresh Request Interval and Refresh Cycle Execution

The refresh request interval is determined as in a DRAM interface, by the settings of RTCOR and bits CKS2 to CKS0 in RTMCSR. The numbers of states required for pseudo-static RAM read/write cycles and refresh cycles are the same as for DRAM (see table 7.4). The state transitions are as shown in figure 7.3.

Pseudo-Static RAM Control Signals

Figure 7.15 shows the control signals for pseudo-static RAM read, write, and refresh cycles.

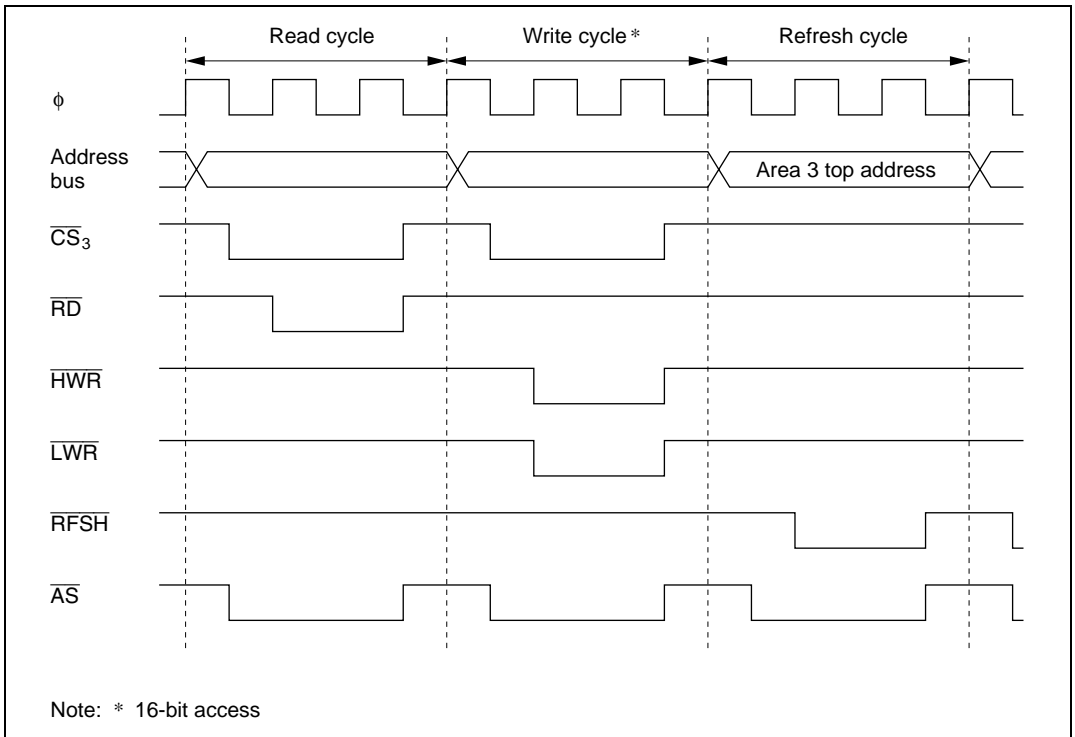

Figure 7.15 Pseudo-Static RAM Control Signal Output Timing

Refresh Cycle Priority Order

When there are simultaneous bus requests, the priority order is:

(High) External bus master > refresh controller > DMA controller > CPU (Low)

For details see section 6.3.7, Bus Arbiter Operation.

Wait State Insertion

When bit AST3 is set to 1 in ASTCR, the wait state controller (WSC) can insert wait states into bus cycles and refresh cycles. For details see section 6.3.5, Wait Modes.

Self-Refresh Mode

Some pseudo-static RAM devices have a self-refresh function. After the SRFMD bit is set to 1 in RFSHCR, when a transition to software standby mode occurs, the H8/3048B Group's \overline{CS}_3 output goes high and its \overline{RFSH} output goes low so that the pseudo-static RAM self-refresh function can be used. On exit from software standby mode, the \overline{RFSH} output goes high.

Table 7.8 shows the pin states in software standby mode. Figure 7.16 shows the signal output timing.

Table 7.8 Pin States in Software Standby Mode (2) (PSRAME = 1, DRAME = 0)

Signal	Software Standby Mode	
	SRFMD = 0	SRFMD = 1 (Self-Refresh Mode)
\overline{CS}_3	High	High
\overline{RD}	High-impedance	High-impedance
\overline{HWR}	High-impedance	High-impedance
\overline{LWR}	High-impedance	High-impedance
\overline{RFSH}	High	Low

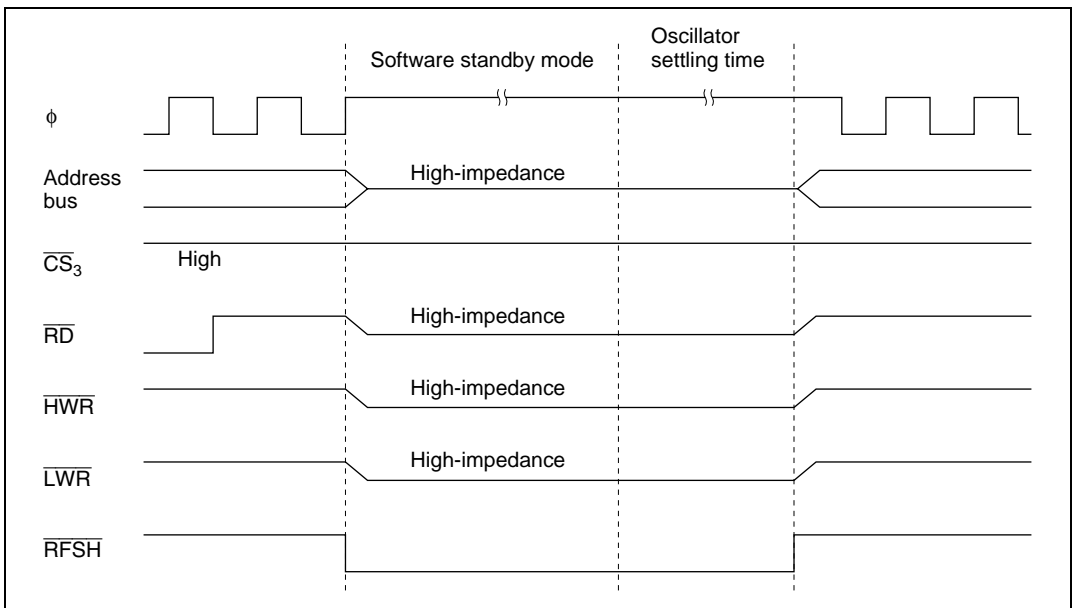

Figure 7.16 Signal Output Timing in Self-Refresh Mode (PSRAME = 1, DRAME = 0)

Operation in Power-Down State

The refresh controller operates in sleep mode. It does not operate in hardware standby mode. In software standby mode RTCNT is initialized, but RFSHCR, RTMCSR bits 5 to 3, and RTCOR retain their settings prior to the transition to software standby mode.

Example

Pseudo-static RAM may have separate $\overline{\text{OE}}$ and $\overline{\text{RFSH}}$ pins, or these may be combined into a single $\overline{\text{OE/RFSH}}$ pin. Figure 7.17 shows an example of a circuit for generating an $\overline{\text{OE/RFSH}}$ signal.

Check the device characteristics carefully, and design a circuit that fits them. Figure 7.18 shows a setup procedure to be followed by a program.

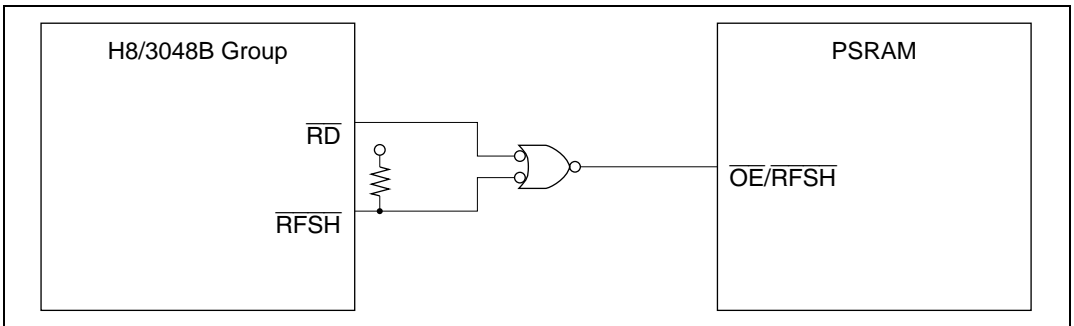

Figure 7.17 Interconnection to Pseudo-Static RAM with $\overline{\text{OE/RFSH}}$ Signal (Example)

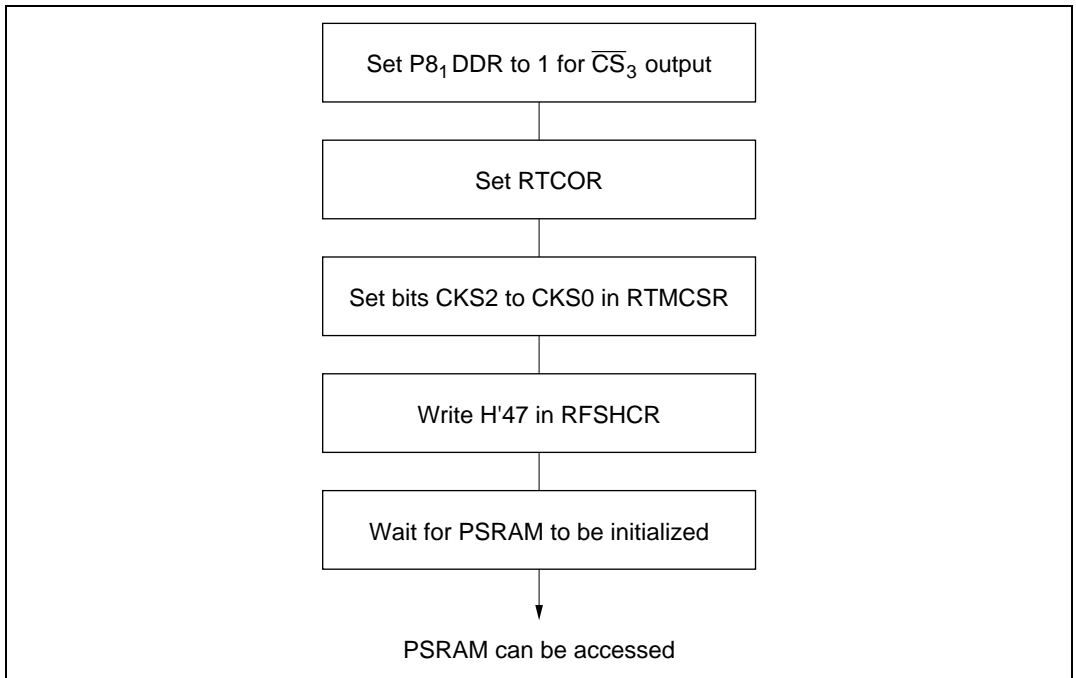

Figure 7.18 Setup Procedure for Pseudo-Static RAM

7.3.4 Interval Timer

To use the refresh controller as an interval timer, clear the PSRAME and DRAME both to 0. After setting RTCOR, select a clock source with bits CKS2 to CKS0 in RTMCSR, and set the CMIE bit to 1.

Timing of Setting of Compare Match Flag and Clearing by Compare Match

The CMF flag in RTCSR is set to 1 by a compare match signal output when the RTCOR and RTCNT values match. The compare match signal is generated in the last state in which the values match (when RTCNT is updated from the matching value to a new value). Accordingly, when RTCNT and RTCOR match, the compare match signal is not generated until the next counter clock pulse. Figure 7.19 shows the timing.

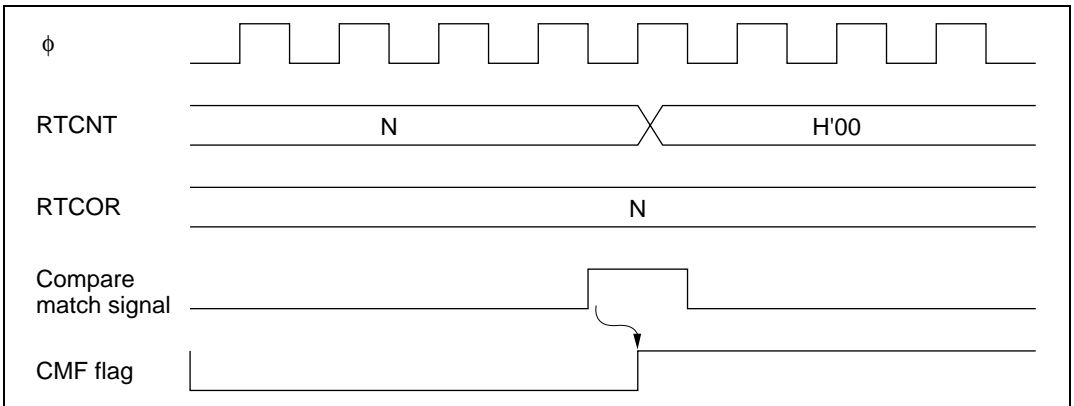

Figure 7.19 Timing of Setting of CMF Flag

Operation in Power-Down State

The interval timer function operates in sleep mode. It does not operate in hardware standby mode. In software standby mode RTCNT and RTMCSR bits 7 and 6 are initialized, but RTMCSR bits 5 to 3 and RTCOR retain their settings prior to the transition to software standby mode.

Contention between RTCNT Write and Counter Clear

If a counter clear signal occurs in the T_3 state of an RTCNT write cycle, clearing of the counter takes priority and the write is not performed. See figure 7.20.

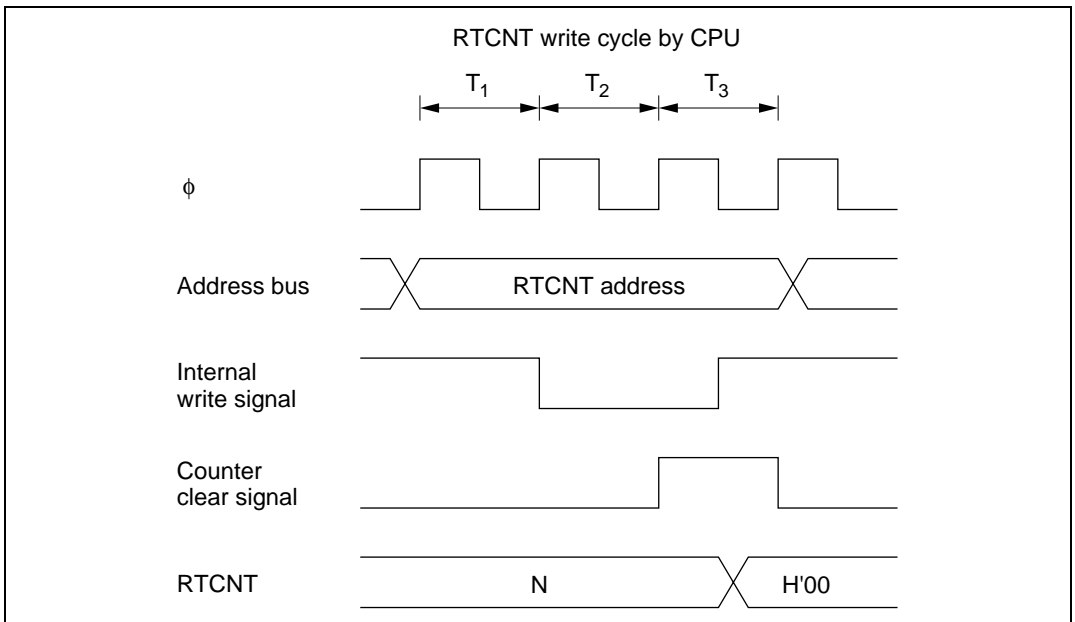

Figure 7.20 Contention between RTCNT Write and Clear

Contention between RTCNT Write and Increment

If an increment pulse occurs in the T_3 state of an RTCNT write cycle, writing takes priority and RTCNT is not incremented. See figure 7.21.

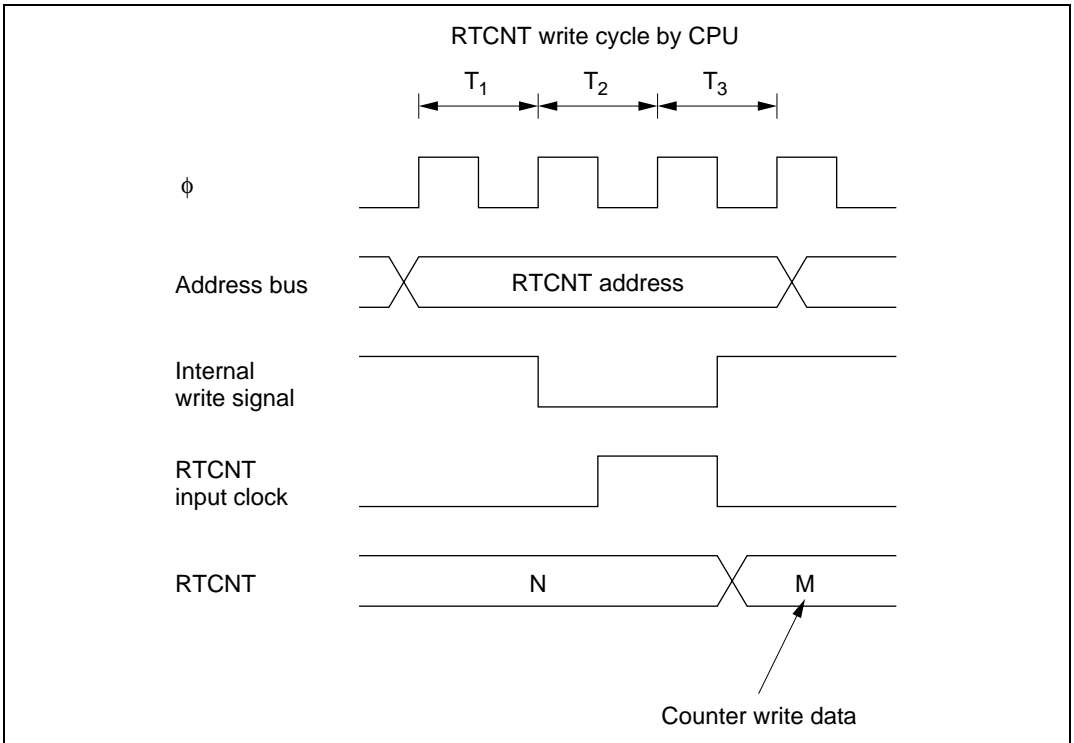

Figure 7.21 Contention between RTCNT Write and Increment

Contention between RTCOR Write and Compare Match

If a compare match occurs in the T_3 state of an RTCOR write cycle, writing takes priority and the compare match signal is inhibited. See figure 7.22.

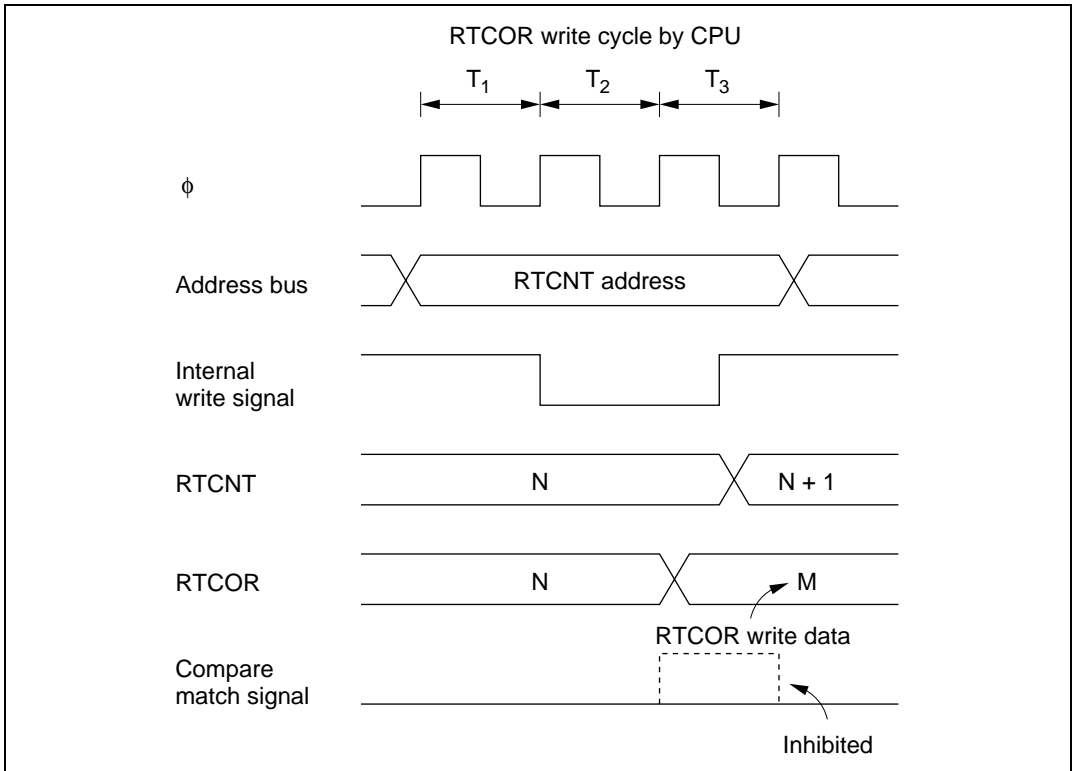
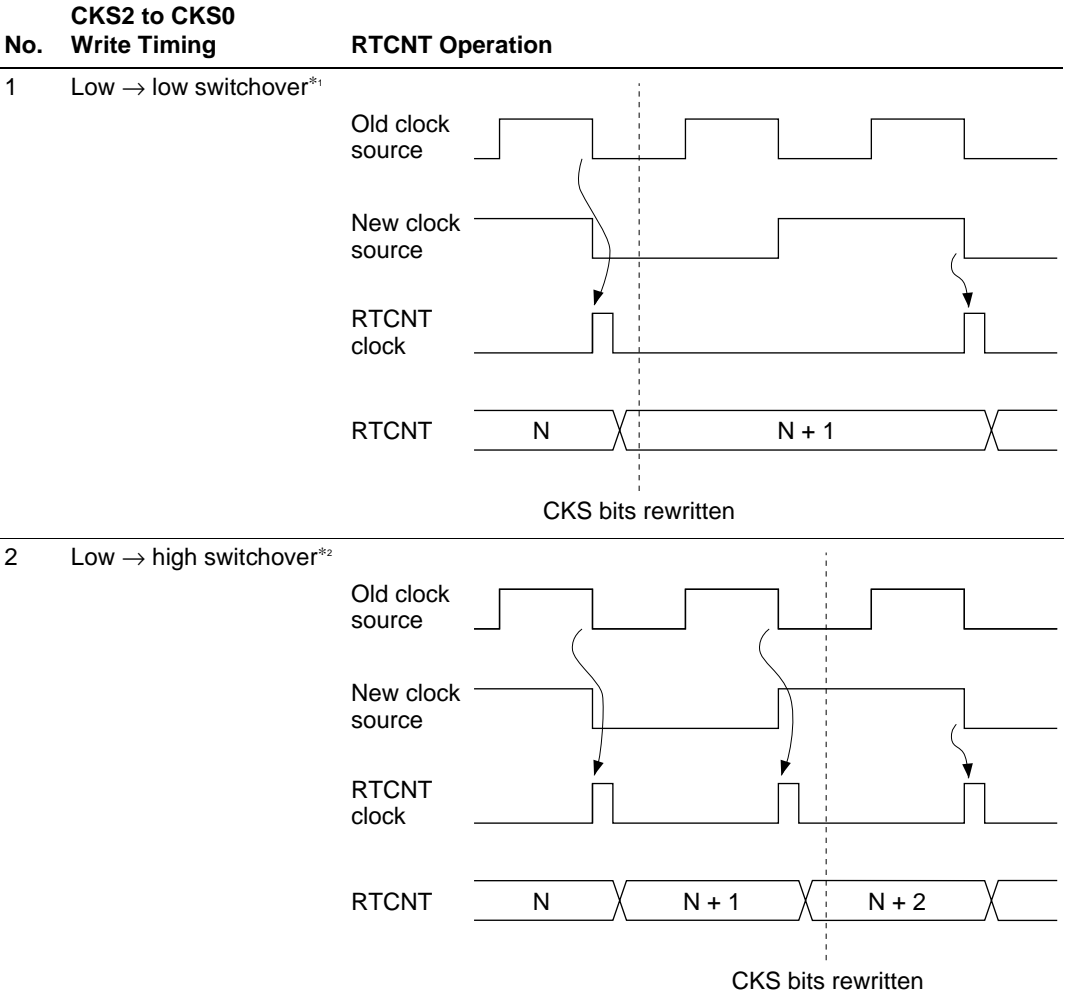

Figure 7.22 Contention between RTCOR Write and Compare Match

RTCNT Operation at Internal Clock Source Switchover

Switching internal clock sources may cause RTCNT to increment, depending on the switchover timing. Table 7.9 shows the relation between the time of the switchover (by writing to bits CKS2 to CKS0) and the operation of RTCNT.

The RTCNT input clock is generated from the internal clock source by detecting the falling edge of the internal clock. If a switchover is made from a high clock source to a low clock source, as in case No. 3 in table 7.9, the switchover will be regarded as a falling edge, an RTCNT clock pulse will be generated, and RTCNT will be incremented.

Table 7.9 Internal Clock Switchover and RTCNT Operation

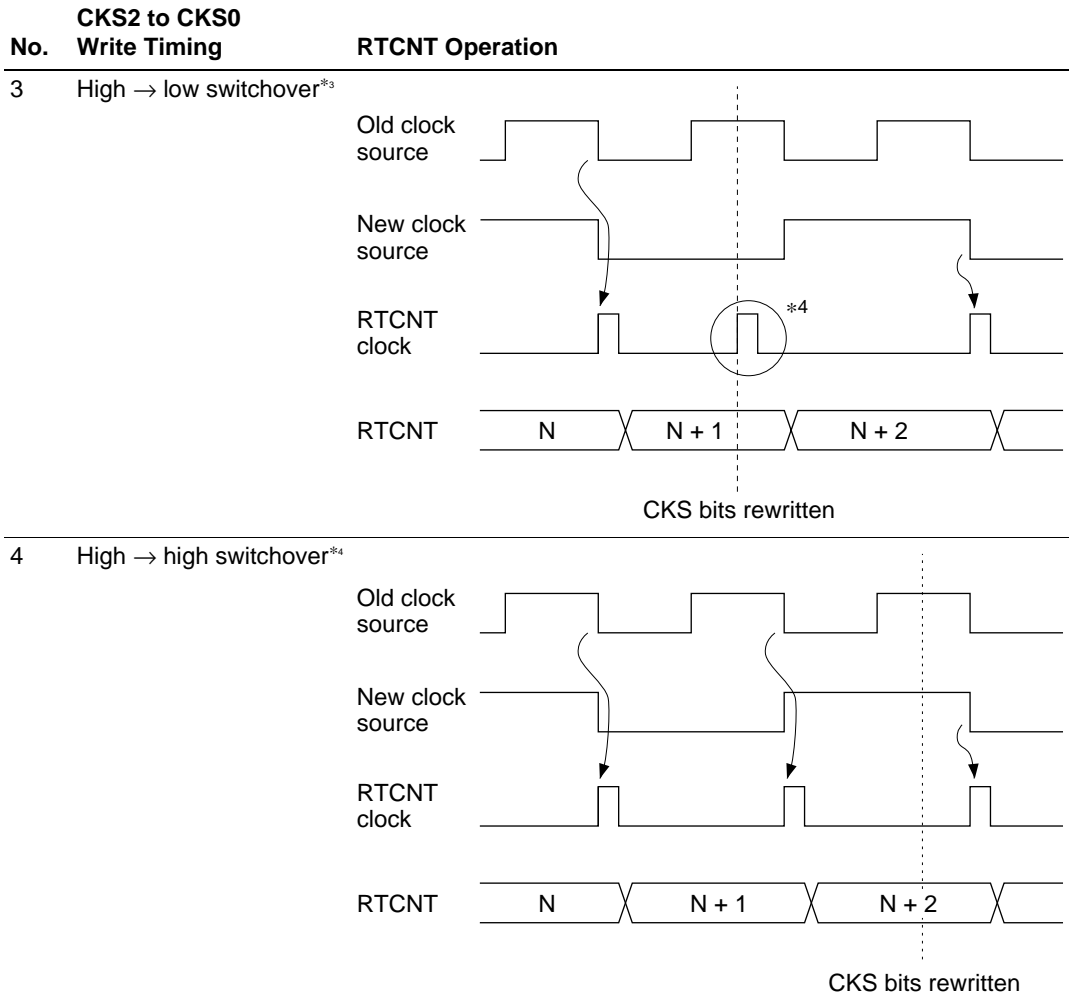

- Notes:
1. Including switchovers from a low clock source to the halted state, and from the halted state to a low clock source.
 2. Including switchover from the halted state to a high clock source.
 3. Including switchover from a high clock source to the halted state.
 4. The switchover is regarded as a falling edge, causing RTCNT to increment.

7.4 Interrupt Source

Compare match interrupts (CMI) can be generated when the refresh controller is used as an interval timer. Compare match interrupt requests are masked/unmasked with the CMIE bit of RTMCSR.

7.5 Usage Notes

When using the DRAM or pseudo-static RAM refresh function, note the following points:

- With the refresh controller, if directly connected DRAM or PSRAM is disconnected*, the $P8_0/\overline{RFSH}/\overline{IRQ}_0$ pin and the $P8_1/\overline{CS}_3/\overline{IRQ}_1$ pin may both become low-level outputs simultaneously.

Note: * When the DRAM enable bit (DRAME) or PSRAM enable bit (PSRAME) in the refresh control register (RFSHCR) is cleared to 0 after being set to 1.

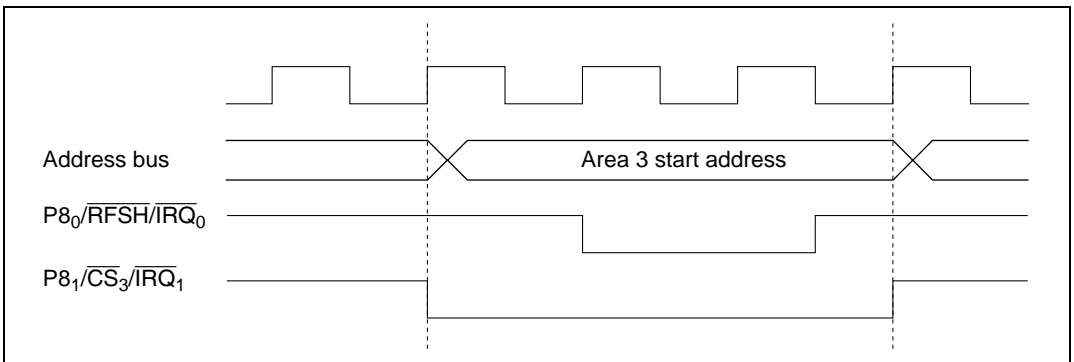

Figure 7.23 Operation when DRAM/PSRAM Connection Is Switched

- Refresh cycles are not executed while the bus is released, during software standby mode, and when a bus cycle is greatly prolonged by insertion of wait states. When these conditions occur, other means of refreshing are required.
- If refresh requests occur while the bus is released, the first request is held and one refresh cycle is executed after the bus-released state ends. Figure 7.24 shows the bus cycles in this case.

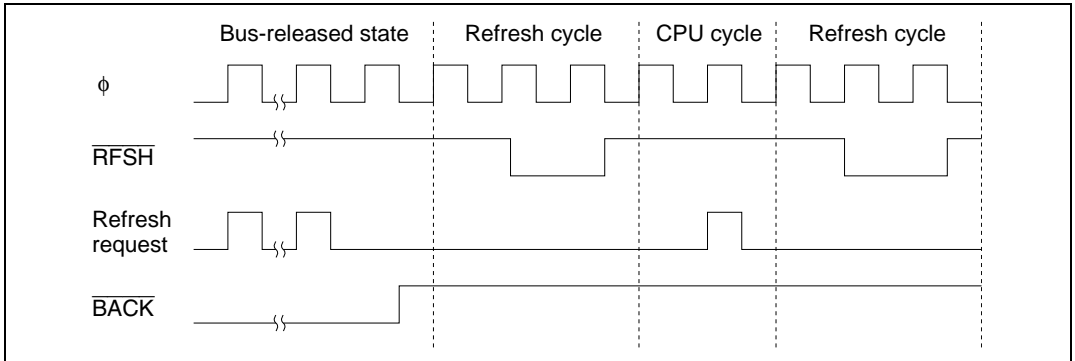

Figure 7.24 Refresh Cycles when Bus Is Released

- If a bus cycle is prolonged by insertion of wait states, the first refresh request is held, as in the bus-released state.
- If there is contention with a bus request from an external bus master when making a transition to software standby mode, a one-state bus-released state may occur immediately before the transition to software standby mode (see figure 7.25).

When using software standby mode, clear the BRLE bit to 0 in BRCCR before executing the SLEEP instruction.

When making a transition to self-refresh mode, the strobe waveform output may not be guaranteed due to the same kind of contention. This, too, can be prevented by clearing the BRLE bit to 0 in BRCCR.

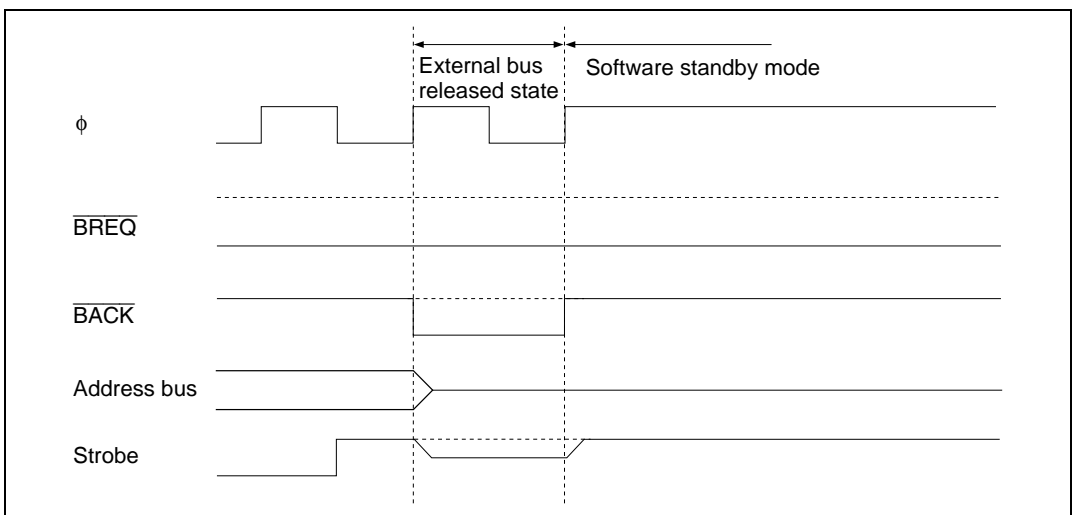

Figure 7.25 Contention between Bus-Released State and Software Standby Mode

Section 8 DMA Controller

8.1 Overview

The H8/3048B Group has an on-chip DMA controller (DMAC) that can transfer data on up to four channels.

When the DMA controller is not used, it can be independently halted to conserve power. For details see section 20.6, Module Standby Function.

8.1.1 Features

DMAC features are listed below.

- Selection of short address mode or full address mode

Short address mode:

- 8-bit source address and 24-bit destination address, or vice versa
- Maximum four channels available
- Selection of I/O mode, idle mode, or repeat mode

Full address mode:

- 24-bit source and destination addresses
 - Maximum two channels available
 - Selection of normal mode or block transfer mode
- Directly addressable 16-Mbyte address space
 - Selection of byte or word transfer
 - Activation by internal interrupts, external requests, or auto-request (depending on transfer mode)
 - 16-bit integrated timer unit (ITU) compare match/input capture interrupts (four)
 - Serial communication interface (SCI channel 0) transmit-data-empty/receive-data-full interrupts
 - External requests
 - Auto-request

8.1.2 Block Diagram

Figure 8.1 shows a DMAC block diagram.

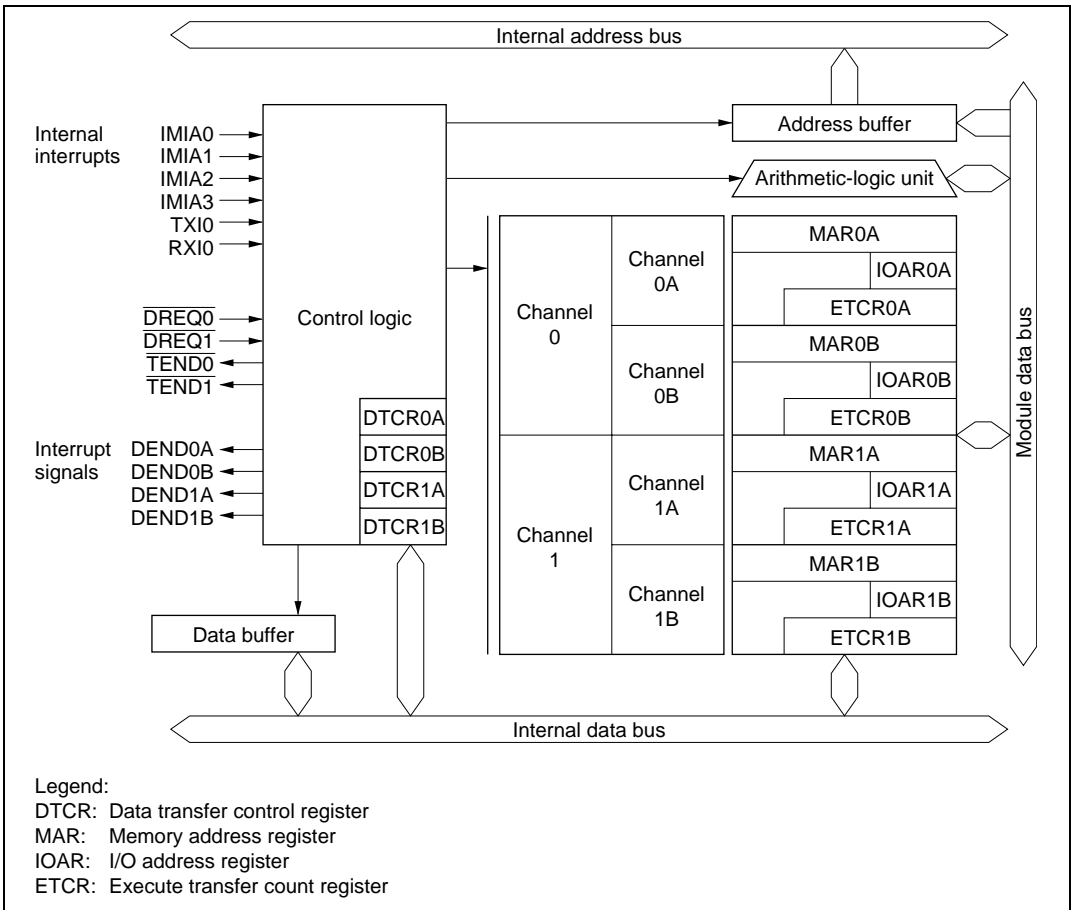

Figure 8.1 Block Diagram of DMAC

8.1.3 Functional Overview

Table 8.1 gives an overview of the DMAC functions.

Table 8.1 DMAC Functional Overview

Transfer Mode		Activation	Address Reg. Length	
			Source	Destination
Short address mode	I/O mode	<ul style="list-style-type: none"> Compare match/ input capture A interrupts from ITU channels 0 to 3 Transmit-data-empty interrupt from SCI channel 0 	24	8
	<ul style="list-style-type: none"> Transfers one byte or one word per request Increments or decrements the memory address by 1 or 2 Executes 1 to 65,536 transfers 			
	Idle mode		<ul style="list-style-type: none"> Receive-data-full interrupt from SCI channel 0 	8
	<ul style="list-style-type: none"> Transfers one byte or one word per request Holds the memory address fixed Executes 1 to 65,536 transfers 	<ul style="list-style-type: none"> External request 	24	8
	Repeat mode			
	<ul style="list-style-type: none"> Transfers one byte or one word per request Increments or decrements the memory address by 1 or 2 Executes a specified number (1 to 255) of transfers, then returns to the initial state and continues 			

Transfer Mode		Activation	Address Reg. Length	
			Source	Destination
Full address mode	Normal mode	<ul style="list-style-type: none"> • Auto-request • External request 	24	24
	<ul style="list-style-type: none"> • Auto-request <ul style="list-style-type: none"> — Retains the transfer request internally — Executes a specified number (1 to 65,536) of transfers continuously — Selection of burst mode or cycle-steal mode • External request <ul style="list-style-type: none"> — Transfers one byte or one word per request — Executes 1 to 65,536 transfers 			
	Block transfer	<ul style="list-style-type: none"> • Compare match/ input capture A interrupts from ITU channels 0 to 3 • External request 	24	24
	<ul style="list-style-type: none"> • Transfers one block of a specified size per request • Executes 1 to 65,536 transfers • Allows either the source or destination to be a fixed block area • Block size can be 1 to 255 bytes or words 			

8.1.4 Input/Output Pins

Table 8.2 lists the DMAC pins.

Table 8.2 DMAC Pins

Channel	Name	Abbreviation	Input/Output	Function
0	DMA request 0	DREQ ₀	Input	External request for DMAC channel 0
	Transfer end 0	TEND ₀	Output	Transfer end on DMAC channel 0
1	DMA request 1	DREQ ₁	Input	External request for DMAC channel 1
	Transfer end 1	TEND ₁	Output	Transfer end on DMAC channel 1

Note: External requests cannot be made to channel A in short address mode.

8.1.5 Register Configuration

Table 8.3 lists the DMAC registers.

Table 8.3 DMAC Registers

Channel	Address*	Name	Abbreviation	R/W	Initial Value
0	H'FF20	Memory address register 0AR	MAR0AR	R/W	H'FF
	H'FF21	Memory address register 0AE	MAR0AE	R/W	Undetermined
	H'FF22	Memory address register 0AH	MAR0AH	R/W	Undetermined
	H'FF23	Memory address register 0AL	MAR0AL	R/W	Undetermined
	H'FF26	I/O address register 0A	IOAR0A	R/W	Undetermined
	H'FF24	Execute transfer count register 0AH	ETCR0AH	R/W	Undetermined
	H'FF25	Execute transfer count register 0AL	ETCR0AL	R/W	Undetermined
	H'FF27	Data transfer control register 0A	DTCR0A	R/W	H'00
	H'FF28	Memory address register 0BR	MAR0BR	R/W	H'FF
	H'FF29	Memory address register 0BE	MAR0BE	R/W	Undetermined
	H'FF2A	Memory address register 0BH	MAR0BH	R/W	Undetermined
	H'FF2B	Memory address register 0BL	MAR0BL	R/W	Undetermined
	H'FF2E	I/O address register 0B	IOAR0B	R/W	Undetermined
	H'FF2C	Execute transfer count register 0BH	ETCR0BH	R/W	Undetermined
	H'FF2D	Execute transfer count register 0BL	ETCR0BL	R/W	Undetermined
	H'FF2F	Data transfer control register 0B	DTCR0B	R/W	H'00
1	H'FF30	Memory address register 1AR	MAR1AR	R/W	H'FF
	H'FF31	Memory address register 1AE	MAR1AE	R/W	Undetermined
	H'FF32	Memory address register 1AH	MAR1AH	R/W	Undetermined
	H'FF33	Memory address register 1AL	MAR1AL	R/W	Undetermined
	H'FF36	I/O address register 1A	IOAR1A	R/W	Undetermined
	H'FF34	Execute transfer count register 1AH	ETCR1AH	R/W	Undetermined
	H'FF35	Execute transfer count register 1AL	ETCR1AL	R/W	Undetermined
	H'FF37	Data transfer control register 1A	DTCR1A	R/W	H'00
	H'FF38	Memory address register 1BR	MAR1BR	R/W	H'FF
	H'FF39	Memory address register 1BE	MAR1BE	R/W	Undetermined
	H'FF3A	Memory address register 1BH	MAR1BH	R/W	Undetermined
	H'FF3B	Memory address register 1BL	MAR1BL	R/W	Undetermined
	H'FF3E	I/O address register 1B	IOAR1B	R/W	Undetermined
	H'FF3C	Execute transfer count register 1BH	ETCR1BH	R/W	Undetermined
	H'FF3D	Execute transfer count register 1BL	ETCR1BL	R/W	Undetermined
	H'FF3F	Data transfer control register 1B	DTCR1B	R/W	H'00

Note: * The lower 16 bits of the address are indicated.

8.2 Register Descriptions (Short Address Mode)

In short address mode, transfers can be carried out independently on channels A and B. Short address mode is selected by bits DTS2A and DTS1A in data transfer control register A (DTCRA) as indicated in table 8.4.

Table 8.4 Selection of Short and Full Address Modes

Channel	Bit 2: DTS2A	Bit 1: DTS1A	Description
0	1	1	DMAC channel 0 operates as one channel in full address mode
	Other than above		DMAC channels 0A and 0B operate as two independent channels in short address mode
1	1	1	DMAC channel 1 operates as one channel in full address mode
	Other than above		DMAC channels 1A and 1B operate as two independent channels in short address mode

8.2.1 Memory Address Registers (MAR)

A memory address register (MAR) is a 32-bit readable/writable register that specifies a source or destination address. The transfer direction is determined automatically from the activation source.

An MAR consists of four 8-bit registers designated MARR, MARE, MARH, and MARL. All bits of MARR are reserved: they cannot be modified and are always read as 1.

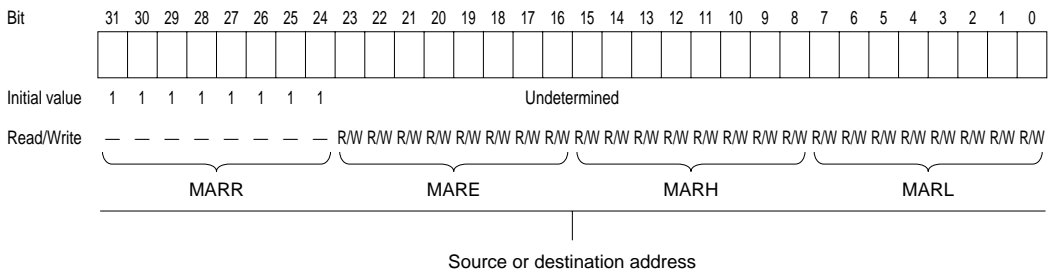

An MAR functions as a source or destination address register depending on how the DMAC is activated: as a destination address register if activation is by a receive-data-full interrupt from the serial communication interface (SCI) (channel 0), and as a source address register otherwise.

The MAR value is incremented or decremented each time one byte or word is transferred, automatically updating the source or destination memory address. For details, see section 8.2.4, Data Transfer Control Registers (DTCR).

The MARs are not initialized by a reset or in standby mode.

8.2.2 I/O Address Registers (IOAR)

An I/O address register (IOAR) is an 8-bit readable/writable register that specifies a source or destination address. The IOAR value is the lower 8 bits of the address. The upper 16 address bits are all 1 (H'FFFF).

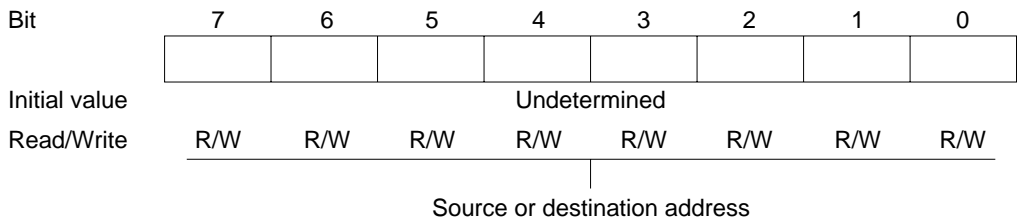

An IOAR functions as a source or destination address register depending on how the DMAC is activated: as a source address register if activation is by a receive-data-full interrupt from the SCI (channel 0), and as a destination address register otherwise.

The IOAR value is held fixed. It is not incremented or decremented when a transfer is executed.

The IOARs are not initialized by a reset or in standby mode.

8.2.3 Execute Transfer Count Registers (ETCR)

An execute transfer count register (ETCR) is a 16-bit readable/writable register that specifies the number of transfers to be executed. These registers function in one way in I/O mode and idle mode, and another way in repeat mode.

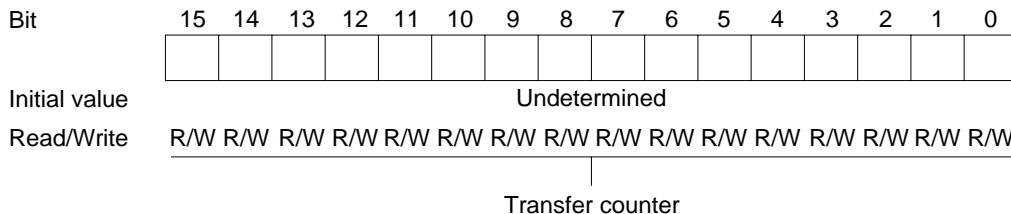
I/O mode and idle mode

In I/O mode and idle mode, ETCR functions as a 16-bit counter. The count is decremented by 1 each time one transfer is executed. The transfer ends when the count reaches H'0000.

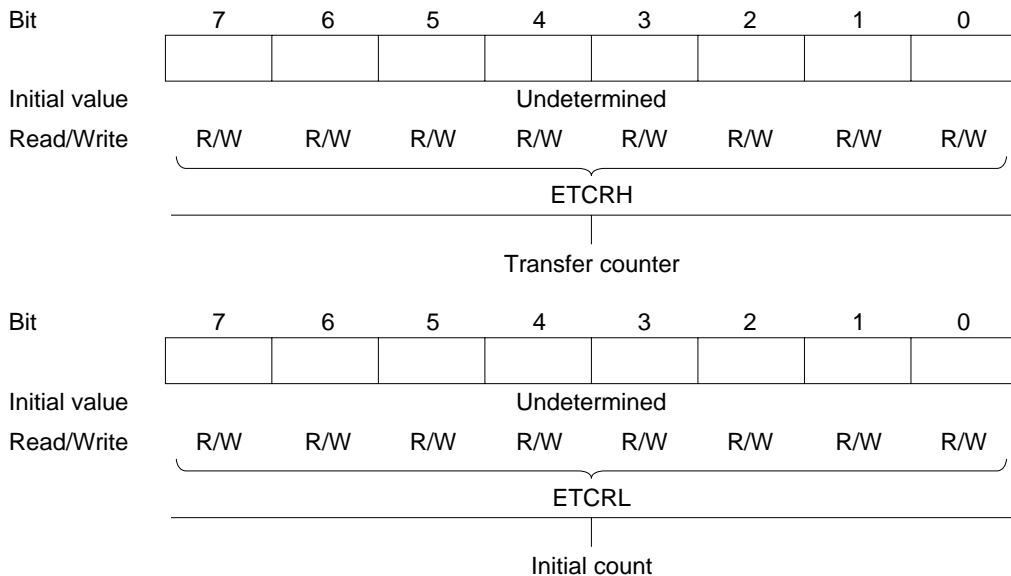
Repeat mode

In repeat mode, ETCRH functions as an 8-bit transfer counter and ETCRL holds the initial transfer count. ETCRH is decremented by 1 each time one transfer is executed. When ETCRH reaches H'00, the value in ETCRL is reloaded into ETCRH and the same operation is repeated.

The ETCRs are not initialized by a reset or in standby mode.

8.2.4 Data Transfer Control Registers (DTCR)

A data transfer control register (DTCR) is an 8-bit readable/writable register that controls the operation of one DMAC channel.

Bit	7	6	5	4	3	2	1	0
	DTE	DTSZ	DTID	RPE	DTIE	DTS2	DTS1	DTS0
Initial value	0	0	0	0	0	0	0	0
Read/Write	R/W	R/W	R/W	R/W	R/W	R/W	R/W	R/W

<p>Data transfer enable Enables or disables data transfer</p>	<p>Data transfer size Selects byte or word size</p>	<p>Data transfer increment/decrement Selects whether to increment or decrement the memory address register</p>	<p>Repeat enable Selects repeat mode</p>	<p>Data transfer interrupt enable Enables or disables the CPU interrupt at the end of the transfer</p>	<p>Data transfer select These bits select the data transfer activation source</p>
--	--	---	---	---	--

The DTCRs are initialized to H'00 by a reset and in standby mode.

Bit 7—Data Transfer Enable (DTE): Enables or disables data transfer on a channel. When the DTE bit is set to 1, the channel waits for a transfer to be requested, and executes the transfer when activated as specified by bits DTS2 to DTS0. When DTE is 0, the channel is disabled and does not accept transfer requests. DTE is set to 1 by reading the register when DTE is 0, then writing 1.

Bit 7: DTE	Description
0	Data transfer is disabled. In I/O mode or idle mode, DTE is cleared to 0 when the specified number of transfers have been completed. (Initial value)
1	Data transfer is enabled

If DTIE is set to 1, a CPU interrupt is requested when DTE is cleared to 0.

Bit 6—Data Transfer Size (DTSZ): Selects the data size of each transfer.

Bit 6: DTSZ	Description
0	Byte-size transfer (Initial value)
1	Word-size transfer

Bit 5—Data Transfer Increment/Decrement (DTID): Selects whether to increment or decrement the memory address register (MAR) after a data transfer in I/O mode or repeat mode.

Bit 5: DTID	Description
0	MAR is incremented after each data transfer <ul style="list-style-type: none"> • If DTSZ = 0, MAR is incremented by 1 after each transfer • If DTSZ = 1, MAR is incremented by 2 after each transfer
1	MAR is decremented after each data transfer <ul style="list-style-type: none"> • If DTSZ = 0, MAR is decremented by 1 after each transfer • If DTSZ = 1, MAR is decremented by 2 after each transfer

MAR is not incremented or decremented in idle mode.

Bit 4—Repeat Enable (RPE): Selects whether to transfer data in I/O mode, idle mode, or repeat mode.

Bit 4: RPE	Bit 3: DTIE	Description
0	0	I/O mode (Initial value)
	1	
1	0	Repeat mode
	1	Idle mode

Operations in these modes are described in sections 8.4.2, I/O Mode, 8.4.3, Idle Mode, and 8.4.4, Repeat Mode.

Bit 3—Data Transfer Interrupt Enable (DTIE): Enables or disables the CPU interrupt (DEND) requested when the DTE bit is cleared to 0.

Bit 3: DTIE	Description
0	The DEND interrupt requested by DTE is disabled (Initial value)
1	The DEND interrupt requested by DTE is enabled

Bits 2 to 0—Data Transfer Select (DTS2, DTS1, DTS0): These bits select the data transfer activation source. Some of the selectable sources differ between channels A and B.*

Note: * Refer to section 8.3.4, Data Transfer Control Registers (DTCR).

Bit 2: DTS2	Bit 1: DTS1	Bit 0: DTS0	Description
0	0	0	Compare match/input capture A interrupt from ITU channel 0 (Initial value)
		1	Compare match/input capture A interrupt from ITU channel 1
	1	0	Compare match/input capture A interrupt from ITU channel 2
		1	Compare match/input capture A interrupt from ITU channel 3
1	0	0	Transmit-data-empty interrupt from SCI channel 0
		1	Receive-data-full interrupt from SCI channel 0
	1	0	Falling edge of \overline{DREQ} input (channel B) Transfer in full address mode (channel A)
		1	Low level of \overline{DREQ} input (channel B) Transfer in full address mode (channel A)

The same internal interrupt can be selected as an activation source for two or more channels at once. In that case the channels are activated in a priority order, highest-priority channel first. For the priority order, see section 8.4.9, DMAC Multiple-Channel Operation.

When a channel is enabled (DTE = 1), its selected DMAC activation source cannot generate a CPU interrupt.

8.3 Register Descriptions (Full Address Mode)

In full address mode the A and B channels operate together. Full address mode is selected as indicated in table 8.4.

8.3.1 Memory Address Registers (MAR)

A memory address register (MAR) is a 32-bit readable/writable register. MARA functions as the source address register of the transfer, and MARB as the destination address register.

An MAR consists of four 8-bit registers designated MARR, MARE, MARH, and MARL. All bits of MARR are reserved: they cannot be modified and are always read as 1.

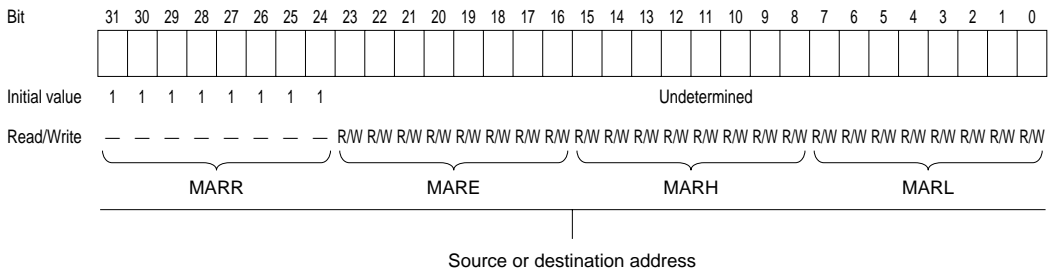

The MAR value is incremented or decremented each time one byte or word is transferred, automatically updating the source or destination memory address. For details, see section 8.3.4, Data Transfer Control Registers (DTCR).

The MARs are not initialized by a reset or in standby mode.

8.3.2 I/O Address Registers (IOAR)

The I/O address registers (IOARs) are not used in full address mode.

8.3.3 Execute Transfer Count Registers (ETCR)

An execute transfer count register (ETCR) is a 16-bit readable/writable register that specifies the number of transfers to be executed. The functions of these registers differ between normal mode and block transfer mode.

Normal mode

ETCRA:

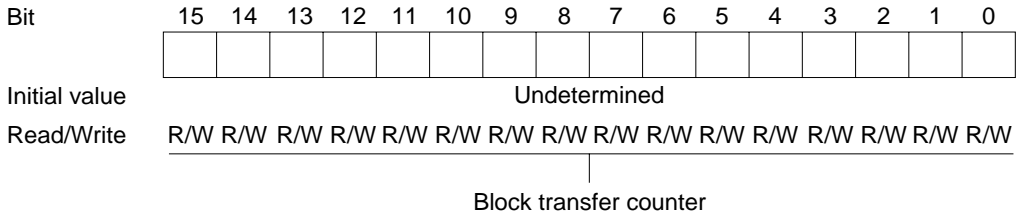

ETCRB: Is not used in normal mode.

In normal mode ETCRA functions as a 16-bit transfer counter. The count is decremented by 1 each time one transfer is executed. The transfer ends when the count reaches H'0000. ETCRB is not used.

Block transfer mode

ETCRA:

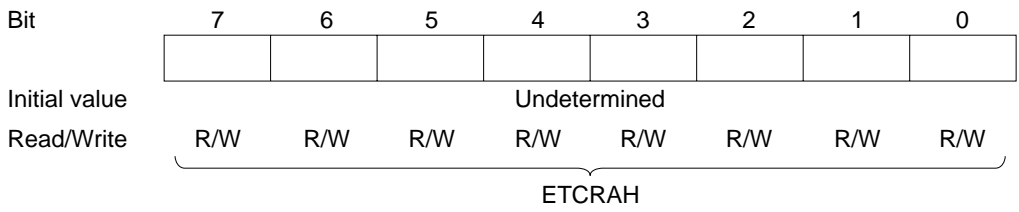

Block size counter

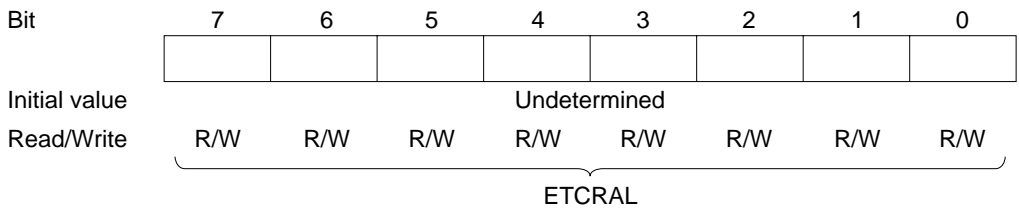

Initial block size

ETCRB:

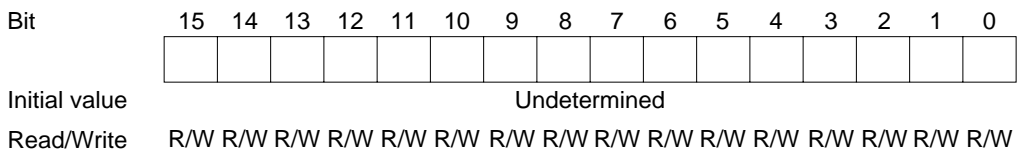

Block transfer counter

In block transfer mode, ETCRAH functions as an 8-bit block size counter. ETCRAL holds the initial block size. ETCRAH is decremented by 1 each time one byte or word is transferred. When the count reaches H'00, ETCRAH is reloaded from ETCRAL. Blocks consisting of an arbitrary number of bytes or words can be transferred repeatedly by setting the same initial block size value in ETCRAH and ETCRAL.

In block transfer mode ETCRB functions as a 16-bit block transfer counter. ETCRB is decremented by 1 each time one block is transferred. The transfer ends when the count reaches H'0000.

The ETCRs are not initialized by a reset or in standby mode.

8.3.4 Data Transfer Control Registers (DTCR)

The data transfer control registers (DTCRs) are 8-bit readable/writable registers that control the operation of the DMAC channels. A channel operates in full address mode when bits DTS2A and DTS1A are both set to 1 in DTCRA. DTCRA and DTCRB have different functions in full address mode.

DTCRA

Bit	7	6	5	4	3	2	1	0
	DTE	DTSZ	SAID	SAIDE	DTIE	DTS2A	DTS1A	DTS0A
Initial value	0	0	0	0	0	0	0	0
Read/Write	R/W	R/W	R/W	R/W	R/W	R/W	R/W	R/W

<p>Data transfer enable Enables or disables data transfer</p>	<p>Data transfer size Selects byte or word size</p>	<p>Data transfer interrupt enable Enables or disables the CPU interrupt at the end of the transfer</p>	<p>Data transfer select 0A Selects block transfer mode</p>
<p>Source address increment/decrement Source address increment/decrement enable These bits select whether the source address register (MARA) is incremented, decremented, or held fixed during the data transfer</p>			<p>Data transfer select 2A and 1A These bits must both be set to 1</p>

DTCRA is initialized to H'00 by a reset and in standby mode.

Bit 7—Data Transfer Enable (DTE): Together with the DTME bit in DTCRB, this bit enables or disables data transfer on the channel. When the DTME and DTE bits are both set to 1, the channel is enabled. If auto-request is specified, data transfer begins immediately. Otherwise, the channel waits for transfers to be requested. When the specified number of transfers have been completed, the DTE bit is automatically cleared to 0. When DTE is 0, the channel is disabled and does not accept transfer requests. DTE is set to 1 by reading the register when DTE is 0, then writing 1.

Bit 7: DTE	Description
0	Data transfer is disabled (DTE is cleared to 0 when the specified number of transfers have been completed) (Initial value)
1	Data transfer is enabled

If DTIE is set to 1, a CPU interrupt is requested when DTE is cleared to 0.

Bit 6—Data Transfer Size (DTSZ): Selects the data size of each transfer.

Bit 6: DTSZ	Description
0	Byte-size transfer (Initial value)
1	Word-size transfer

Bit 5—Source Address Increment/Decrement (SAID) and

Bit 4—Source Address Increment/Decrement Enable (SAIDE): These bits select whether the source address register (MARA) is incremented, decremented, or held fixed during the data transfer.

Bit 5: SAID	Bit 4: SAIDE	Description
0	0	MARA is held fixed (Initial value)
	1	MARA is incremented after each data transfer <ul style="list-style-type: none"> If DTSZ = 0, MARA is incremented by 1 after each transfer If DTSZ = 1, MARA is incremented by 2 after each transfer
1	0	MARA is held fixed
	1	MARA is decremented after each data transfer <ul style="list-style-type: none"> If DTSZ = 0, MARA is decremented by 1 after each transfer If DTSZ = 1, MARA is decremented by 2 after each transfer

Bit 3—Data Transfer Interrupt Enable (DTIE): Enables or disables the CPU interrupt (DEND) requested when the DTE bit is cleared to 0.

Bit 3: DTIE	Description
0	The DEND interrupt requested by DTE is disabled (Initial value)
1	The DEND interrupt requested by DTE is enabled

Bits 2 and 1—Data Transfer Select 2A and 1A (DTS2A, DTS1A): A channel operates in full address mode when DTS2A and DTS1A are both set to 1.

Bit 0—Data Transfer Select 0A (DTS0A): Selects normal mode or block transfer mode.

Bit 0: DTS0A	Description
0	Normal mode (Initial value)
1	Block transfer mode

Operations in these modes are described in sections 8.4.5, Normal Mode, and 8.4.6, Block Transfer Mode.

DTCRB

Bit	7	6	5	4	3	2	1	0
	DTME	—	DAID	DAIDE	TMS	DTS2B	DTS1B	DTS0B
Initial value	0	0	0	0	0	0	0	0
Read/Write	R/W	R/W	R/W	R/W	R/W	R/W	R/W	R/W

Data transfer master enable
Enables or disables data transfer, together with the DTE bit, and is cleared to 0 by an interrupt

Reserved bit

Transfer mode select
Selects whether the block area is the source or destination in block transfer mode

**Destination address increment/decrement
Destination address increment/decrement enable**
These bits select whether the destination address register (MARB) is incremented, decremented, or held fixed during the data transfer

Data transfer select 2B to 0B
These bits select the data transfer activation source

DTCRB is initialized to H'00 by a reset and in standby mode.

Bit 7—Data Transfer Master Enable (DTME): Together with the DTE bit in DTCRA, this bit enables or disables data transfer. When the DTME and DTE bits are both set to 1, the channel is enabled. When an NMI interrupt occurs DTME is cleared to 0, suspending the transfer so that the CPU can use the bus. The suspended transfer resumes when DTME is set to 1 again. For further information on operation in block transfer mode, see section 8.6.6, NMI Interrupts and Block Transfer Mode.

DTME is set to 1 by reading the register while DTME = 0, then writing 1.

Bit 7: DTME	Description
0	Data transfer is disabled (DTME is cleared to 0 when an NMI interrupt occurs) (Initial value)
1	Data transfer is enabled

Bit 6—Reserved: Although reserved, this bit can be written and read.

Bit 5—Destination Address Increment/Decrement (DAID) and

Bit 4—Destination Address Increment/Decrement Enable (DAIDE): These bits select whether the destination address register (MARB) is incremented, decremented, or held fixed during the data transfer.

Bit 5: DAID	Bit 4: DAIDE	Description
0	0	MARB is held fixed (Initial value)
	1	MARB is incremented after each data transfer <ul style="list-style-type: none"> If DTSZ = 0, MARB is incremented by 1 after each data transfer If DTSZ = 1, MARB is incremented by 2 after each data transfer
1	0	MARB is held fixed
	1	MARB is decremented after each data transfer <ul style="list-style-type: none"> If DTSZ = 0, MARB is decremented by 1 after each data transfer If DTSZ = 1, MARB is decremented by 2 after each data transfer

Bit 3—Transfer Mode Select (TMS): Selects whether the source or destination is the block area in block transfer mode.

Bit 3: TMS	Description
0	Destination is the block area in block transfer mode (Initial value)
1	Source is the block area in block transfer mode

Bits 2 to 0—Data Transfer Select 2B to 0B (DTS2B, DTS1B, DTS0B): These bits select the data transfer activation source. The selectable activation sources differ between normal mode and block transfer mode.

- Normal mode

Bit 2: DTS2B	Bit 1: DTS1B	Bit 0: DTS0B	Description
0	0	0	Auto-request (burst mode) (Initial value)
		1	Cannot be used
	1	0	Auto-request (cycle-steal mode)
		1	Cannot be used
1	0	0	Cannot be used
		1	Cannot be used
	1	0	Falling edge of \overline{DREQ}
		1	Low level input at \overline{DREQ}

- Block transfer mode

Bit 2: DTS2B	Bit 1: DTS1B	Bit 0: DTS0B	Description
0	0	0	Compare match/input capture A interrupt from ITU channel 0 (Initial value)
		1	Compare match/input capture A interrupt from ITU channel 1
	1	0	Compare match/input capture A interrupt from ITU channel 2
		1	Compare match/input capture A interrupt from ITU channel 3
1	0	0	Cannot be used
		1	Cannot be used
	1	0	Falling edge of \overline{DREQ}
		1	Cannot be used

The same internal interrupt can be selected to activate two or more channels. The channels are activated in a priority order, highest priority first. For the priority order, see section 8.4.9, DMAC Multiple-Channel Operation.

8.4 Operation

8.4.1 Overview

Table 8.5 summarizes the DMAC modes.

Table 8.5 DMAC Modes

Transfer Mode		Activation	Notes
Short address mode	I/O mode	Compare match/input capture A interrupt from ITU channels 0 to 3	<ul style="list-style-type: none"> Up to four channels can operate independently Only the B channels support external requests
	Idle mode	Transmit-data-empty and receive-data-full interrupts from SCI channel 0	
	Repeat mode	External request	
Full address mode	Normal mode	Auto-request	<ul style="list-style-type: none"> A and B channels are paired; up to two channels are available
		External request	
	Block transfer mode	Compare match/input capture A interrupt from ITU channels 0 to 3	<ul style="list-style-type: none"> Burst mode or cycle-steal mode can be selected for auto-requests
External request			

A summary of operations in these modes follows.

I/O Mode

One byte or word is transferred per request. A designated number of these transfers are executed. A CPU interrupt can be requested at completion of the designated number of transfers. One 24-bit address and one 8-bit address are specified. The transfer direction is determined automatically from the activation source.

Idle Mode

One byte or word is transferred per request. A designated number of these transfers are executed. A CPU interrupt can be requested at completion of the designated number of transfers. One 24-bit address and one 8-bit address are specified. The addresses are held fixed. The transfer direction is determined automatically from the activation source.

Repeat Mode

One byte or word is transferred per request. A designated number of these transfers are executed. When the designated number of transfers are completed, the initial address and counter value are restored and operation continues. No CPU interrupt is requested. One 24-bit address and one 8-bit address are specified. The transfer direction is determined automatically from the activation source.

Normal Mode

Auto-request: The DMAC is activated by register setup alone, and continues executing transfers until the designated number of transfers have been completed. A CPU interrupt can be requested at completion of the transfers. Both addresses are 24-bit addresses.

- Cycle-steal mode
The bus is released to another bus master after each byte or word is transferred.
- Burst mode
Unless requested by a higher-priority bus master, the bus is not released until the designated number of transfers have been completed.

External request: One byte or word is transferred per request. A designated number of these transfers are executed. A CPU interrupt can be requested at completion of the designated number of transfers. Both addresses are 24-bit addresses.

Block Transfer Mode

One block of a specified size is transferred per request. A designated number of block transfers are executed. At the end of each block transfer, one address is restored to its initial value. When the designated number of blocks have been transferred, a CPU interrupt can be requested. Both addresses are 24-bit addresses.

8.4.2 I/O Mode

I/O mode can be selected independently for each channel.

One byte or word is transferred at each transfer request in I/O mode. A designated number of these transfers are executed. One address is specified in the memory address register (MAR), the other in the I/O address register (IOAR). The direction of transfer is determined automatically from the activation source. The transfer is from the address specified in IOAR to the address specified in MAR if activated by an SCI0 channel 0 receive-data-full interrupt, and from the address specified in MAR to the address specified in IOAR otherwise.

Table 8.6 indicates the register functions in I/O mode.

Table 8.6 Register Functions in I/O Mode

Register	Function		Initial Setting	Operation
	Activated by SCI0 Receive-Data-Full Interrupt	Other Activation		
23 0 <div style="border: 1px solid black; padding: 5px; width: 100%; text-align: center;"> MAR </div>	Destination address register	Source address register	Destination or source address	Incremented or decremented once per transfer
23 7 0 <div style="border: 1px solid black; padding: 5px; width: 100%; text-align: center;"> All 1s IOAR </div>	Source address register	Destination address register	Source or destination address	Held fixed
15 0 <div style="border: 1px solid black; padding: 5px; width: 100%; text-align: center;"> ETCR </div>	Transfer counter	Transfer counter	Number of transfers	Decrement once per transfer until H'0000 is reached and transfer ends

Legend:

MAR: Memory address register

IOAR: I/O address register

ETCR: Execute transfer count register

MAR and IOAR specify the source and destination addresses. MAR specifies a 24-bit source or destination address, which is incremented or decremented as each byte or word is transferred. IOAR specifies the lower 8 bits of a fixed address. The upper 16 bits are all 1s. IOAR is not incremented or decremented.

Figure 8.2 illustrates how I/O mode operates.

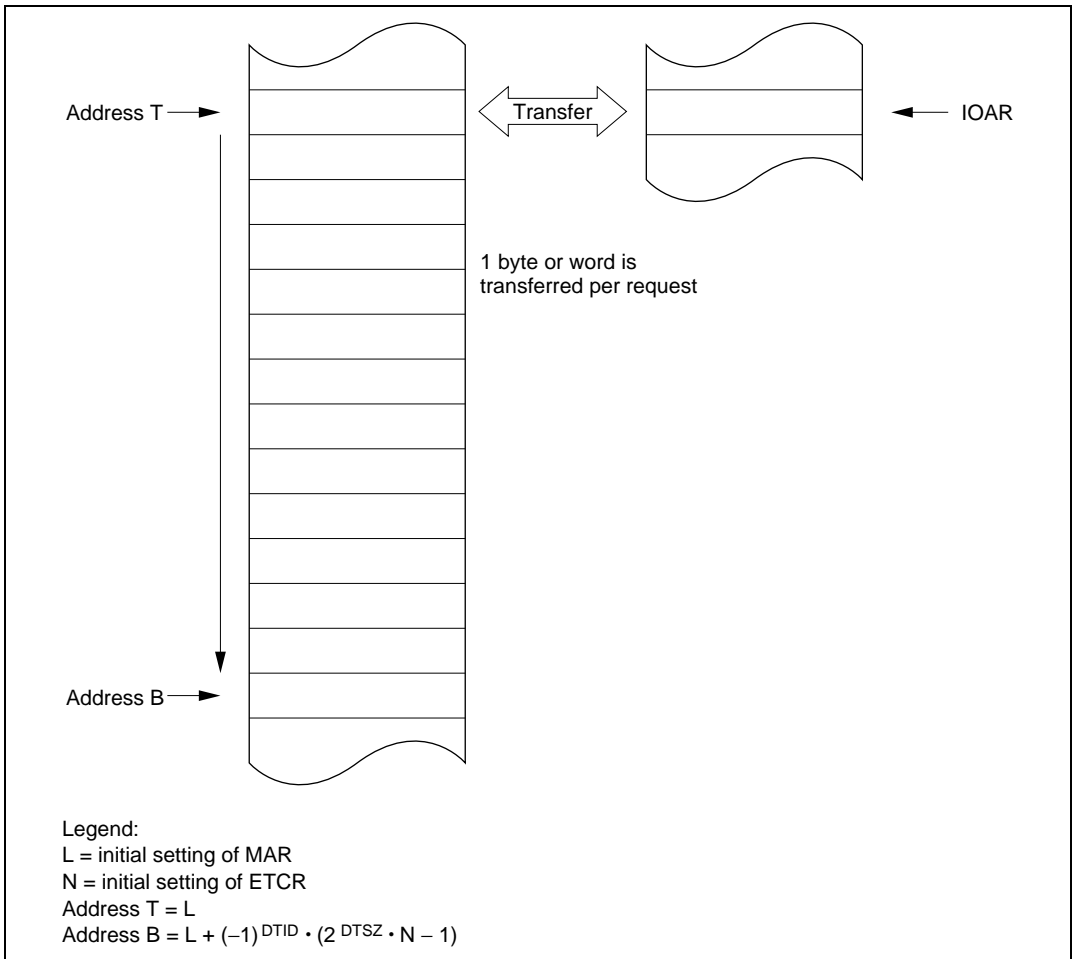

Figure 8.2 Operation in I/O Mode

The transfer count is specified as a 16-bit value in ETCR. The ETCR value is decremented by 1 at each transfer. When the ETCR value reaches H'0000, the DTE bit is cleared and the transfer ends. If the DTIE bit is set to 1, a CPU interrupt is requested at this time. The maximum transfer count is 65,536, obtained by setting ETCR to H'0000.

Transfers can be requested (activated) by compare match/input capture A interrupts from ITU channels 0 to 3, transmit-data-empty and receive-data-full interrupts from SCI channel 0, and external request signals.

For the detailed settings see section 8.2.4, Data Transfer Control Registers (DTCR).

Figure 8.3 shows a sample setup procedure for I/O mode.

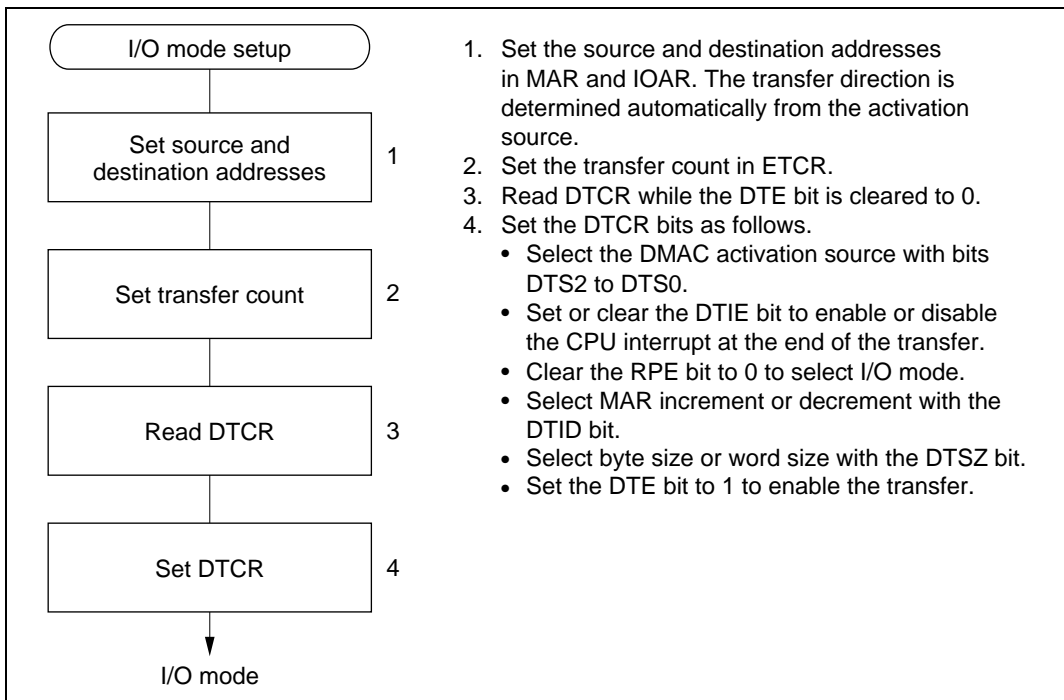

Figure 8.3 I/O Mode Setup Procedure (Example)

8.4.3 Idle Mode

Idle mode can be selected independently for each channel.

One byte or word is transferred at each transfer request in idle mode. A designated number of these transfers are executed. One address is specified in the memory address register (MAR), the other in the I/O address register (IOAR). The direction of transfer is determined automatically from the activation source. The transfer is from the address specified in IOAR to the address specified in MAR if activated by an SCI channel 0 receive-data-full interrupt, and from the address specified in MAR to the address specified in IOAR otherwise.

Table 8.7 indicates the register functions in idle mode.

Table 8.7 Register Functions in Idle Mode

Register	Function			
	Activated by SCIO Receive- Data-Full Interrupt	Other Activation	Initial Setting	Operation
<div style="display: flex; justify-content: space-between;"> 23 0 </div> <div style="border: 1px solid black; padding: 5px; margin: 5px 0;"> <div style="display: flex; justify-content: space-between; border-bottom: 1px dashed black;"> MAR </div> </div>	Destination address register	Source address register	Destination or source address	Held fixed
<div style="display: flex; justify-content: space-between;"> 23 7 0 </div> <div style="border: 1px solid black; padding: 5px; margin: 5px 0;"> <div style="display: flex; justify-content: space-between; border-bottom: 1px dashed black;"> All 1s IOAR </div> </div>	Source address register	Destination address register	Source or destination address	Held fixed
<div style="display: flex; justify-content: space-between;"> 15 0 </div> <div style="border: 1px solid black; padding: 5px; margin: 5px 0;"> <div style="display: flex; justify-content: space-between; border-bottom: 1px dashed black;"> ETCR </div> </div>	Transfer counter	Transfer counter	Number of transfers	Decrementd once per transfer until H'0000 is reached and transfer ends

Legend:

MAR: Memory address register

IOAR: I/O address register

ETCR: Execute transfer count register

MAR and IOAR specify the source and destination addresses. MAR specifies a 24-bit source or destination address. IOAR specifies the lower 8 bits of a fixed address. The upper 16 bits are all 1s. MAR and IOAR are not incremented or decremented.

Figure 8.4 illustrates how idle mode operates.

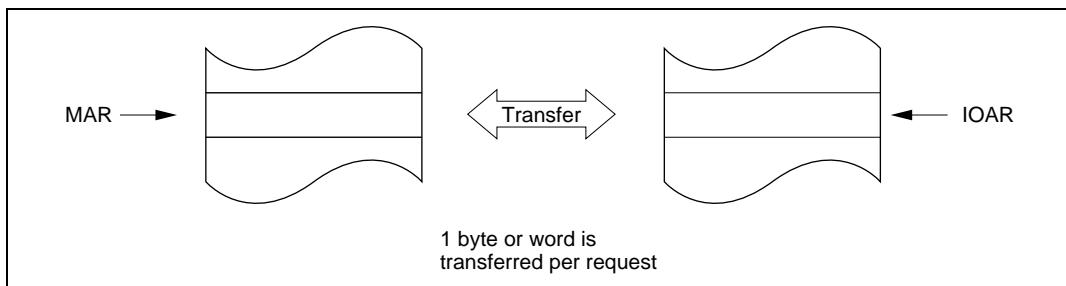
**Figure 8.4 Operation in Idle Mode**

The transfer count is specified as a 16-bit value in ETCR. The ETCR value is decremented by 1 at each transfer. When the ETCR value reaches H'0000, the DTE bit is cleared, the transfer ends, and a CPU interrupt is requested. The maximum transfer count is 65,536, obtained by setting ETCR to H'0000.

Transfers can be requested (activated) by compare match/input capture A interrupts from ITU channels 0 to 3, transmit-data-empty and receive-data-full interrupts from SCI channel 0, and external request signals.

For the detailed settings see section 8.2.4, Data Transfer Control Registers (DTCR).

Figure 8.5 shows a sample setup procedure for idle mode.

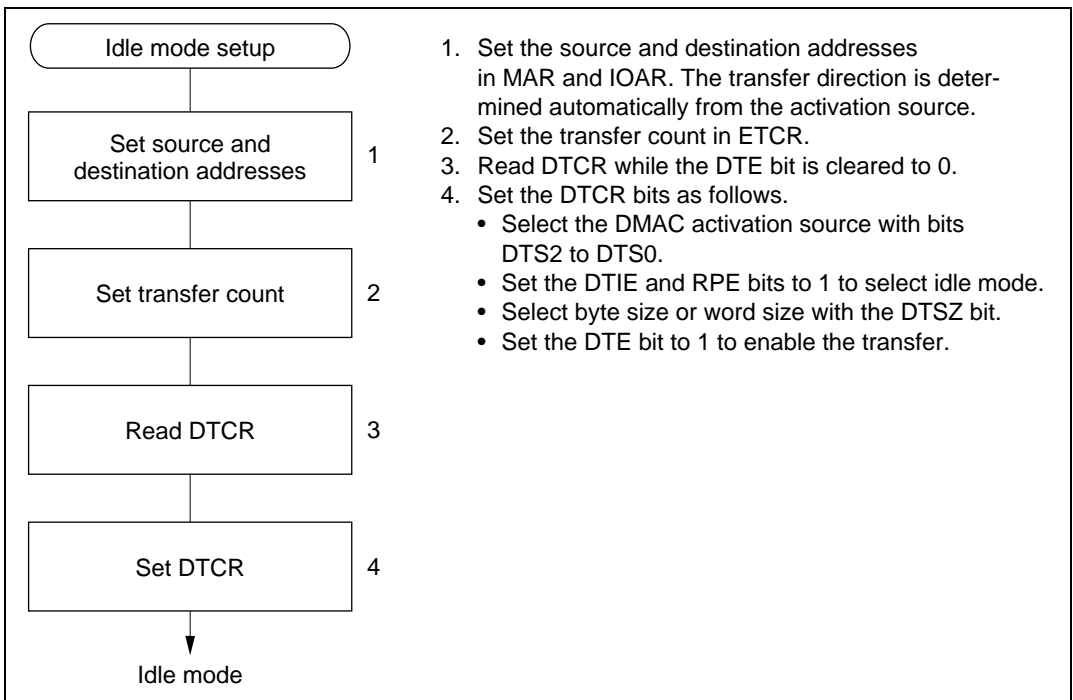

Figure 8.5 Idle Mode Setup Procedure (Example)



8.4.4 Repeat Mode

Repeat mode is useful for cyclically transferring a bit pattern from a table to the programmable timing pattern controller (TPC) in synchronization, for example, with ITU compare match. Repeat mode can be selected for each channel independently.

One byte or word is transferred per request in repeat mode, as in I/O mode. A designated number of these transfers are executed. One address is specified in the memory address register (MAR), the other in the I/O address register (IOAR). At the end of the designated number of transfers, MAR and ETCR are restored to their original values and operation continues. The direction of transfer is determined automatically from the activation source. The transfer is from the address specified in IOAR to the address specified in MAR if activated by an SCI channel 0 receive-data-full interrupt, and from the address specified in MAR to the address specified in IOAR otherwise.

Table 8.8 indicates the register functions in repeat mode.

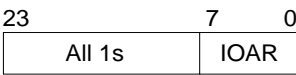
Table 8.8 Register Functions in Repeat Mode

Register	Function			
	Activated by SCIO Receive-Data-Full Interrupt	Other Activation	Initial Setting	Operation
	Destination address register	Source address register	Destination or source address	Incremented or decremented at each transfer until H'0000, then restored to initial value
	Source address register	Destination address register	Source or destination address	Held fixed
	Transfer counter	Transfer counter	Number of transfers	Decrementd once per transfer until H'0000 is reached, then reloaded from ETCRL
	Initial transfer count	Initial transfer count	Number of transfers	Held fixed

Legend:

MAR: Memory address register

IOAR: I/O address register

ETCR: Execute transfer count register

In repeat mode ETCRH is used as the transfer counter while ETCRL holds the initial transfer count. ETCRH is decremented by 1 at each transfer until it reaches H'00, then is reloaded from ETCRL. MAR is also restored to its initial value, which is calculated from the DTSZ and DTID bits in DTCR. Specifically, MAR is restored as follows:

$$\text{MAR} \leftarrow \text{MAR} - (-1)^{\text{DTID}} \cdot 2^{\text{DTSZ}} \cdot \text{ETCRL}$$

ETCRH and ETCRL should be initially set to the same value.

In repeat mode transfers continue until the CPU clears the DTE bit to 0. After DTE is cleared to 0, if the CPU sets DTE to 1 again, transfers resume from the state at which DTE was cleared. No CPU interrupt is requested.

As in I/O mode, MAR and IOAR specify the source and destination addresses. MAR specifies a 24-bit source or destination address. IOAR specifies the lower 8 bits of a fixed address. The upper 16 bits are all 1s. IOAR is not incremented or decremented.

Figure 8.6 illustrates how repeat mode operates.

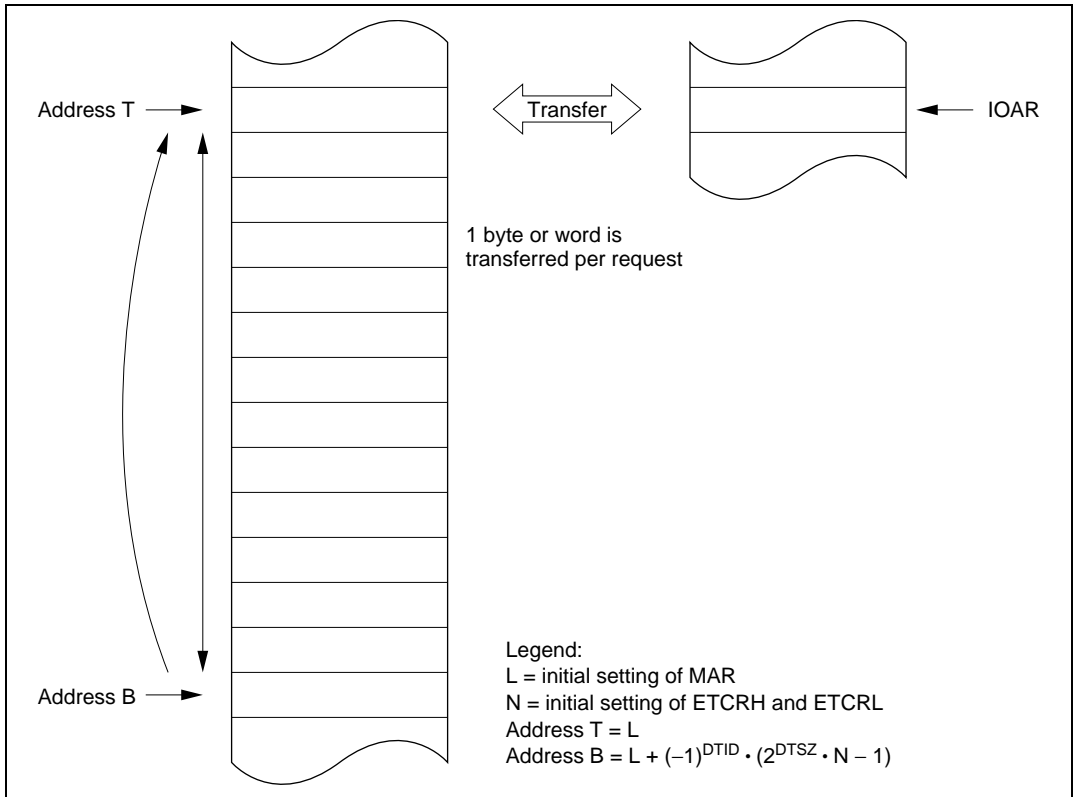

Figure 8.6 Operation in Repeat Mode

The transfer count is specified as an 8-bit value in ETCRH and ETCRL. The maximum transfer count is 255, obtained by setting both ETCRH and ETCRL to H'FF.

Transfers can be requested (activated) by compare match/input capture A interrupts from ITU channels 0 to 3, transmit-data-empty and receive-data-full interrupts from SCI channel 0, and external request signals.

For the detailed settings see section 8.2.4, Data Transfer Control Registers (DTCR).

Figure 8.7 shows a sample setup procedure for repeat mode.

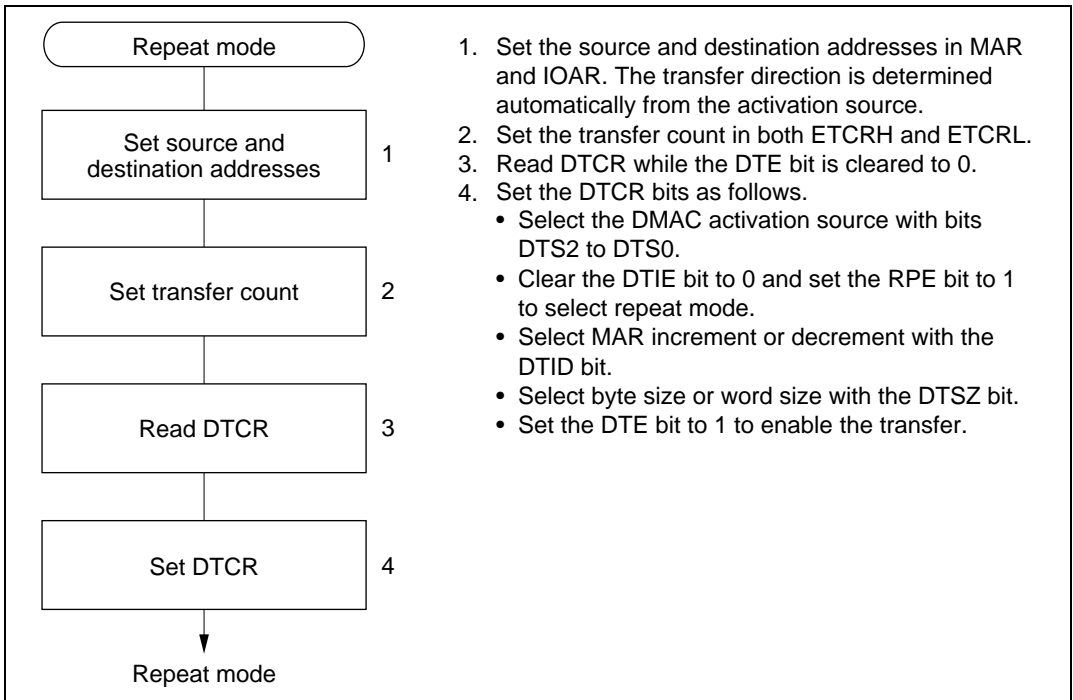

Figure 8.7 Repeat Mode Setup Procedure (Example)

8.4.5 Normal Mode

In normal mode the A and B channels are combined. One byte or word is transferred per request. A designated number of these transfers are executed. Addresses are specified in MARA and MARB. Table 8.9 indicates the register functions in I/O mode.

Table 8.9 Register Functions in Normal Mode

Register	Function	Initial Setting	Operation
23 0 <div style="border: 1px solid black; padding: 2px; display: inline-block; margin: 5px;"> MARA </div>	Source address register	Source address	Incremented or decremented once per transfer, or held fixed
23 0 <div style="border: 1px solid black; padding: 2px; display: inline-block; margin: 5px;"> MARB </div>	Destination address register	Destination address	Incremented or decremented once per transfer, or held fixed
15 0 <div style="border: 1px solid black; padding: 2px; display: inline-block; margin: 5px;"> ETCRA </div>	Transfer counter	Number of transfers	Decrementd once per transfer

Legend:

MARA: Memory address register A

MARB: Memory address register B

ETCRA: Execute transfer count register A

The source and destination addresses are both 24-bit addresses. MARA specifies the source address. MARB specifies the destination address. MARA and MARB can be independently incremented, decremented, or held fixed as data is transferred.

The transfer count is specified as a 16-bit value in ETCRA. The ETCRA value is decremented by 1 at each transfer. When the ETCRA value reaches H'0000, the DTE bit is cleared and the transfer ends. If the DTIE bit is set, a CPU interrupt is requested at this time. The maximum transfer count is 65,536, obtained by setting ETCRA to H'0000.

Figure 8.8 illustrates how normal mode operates.

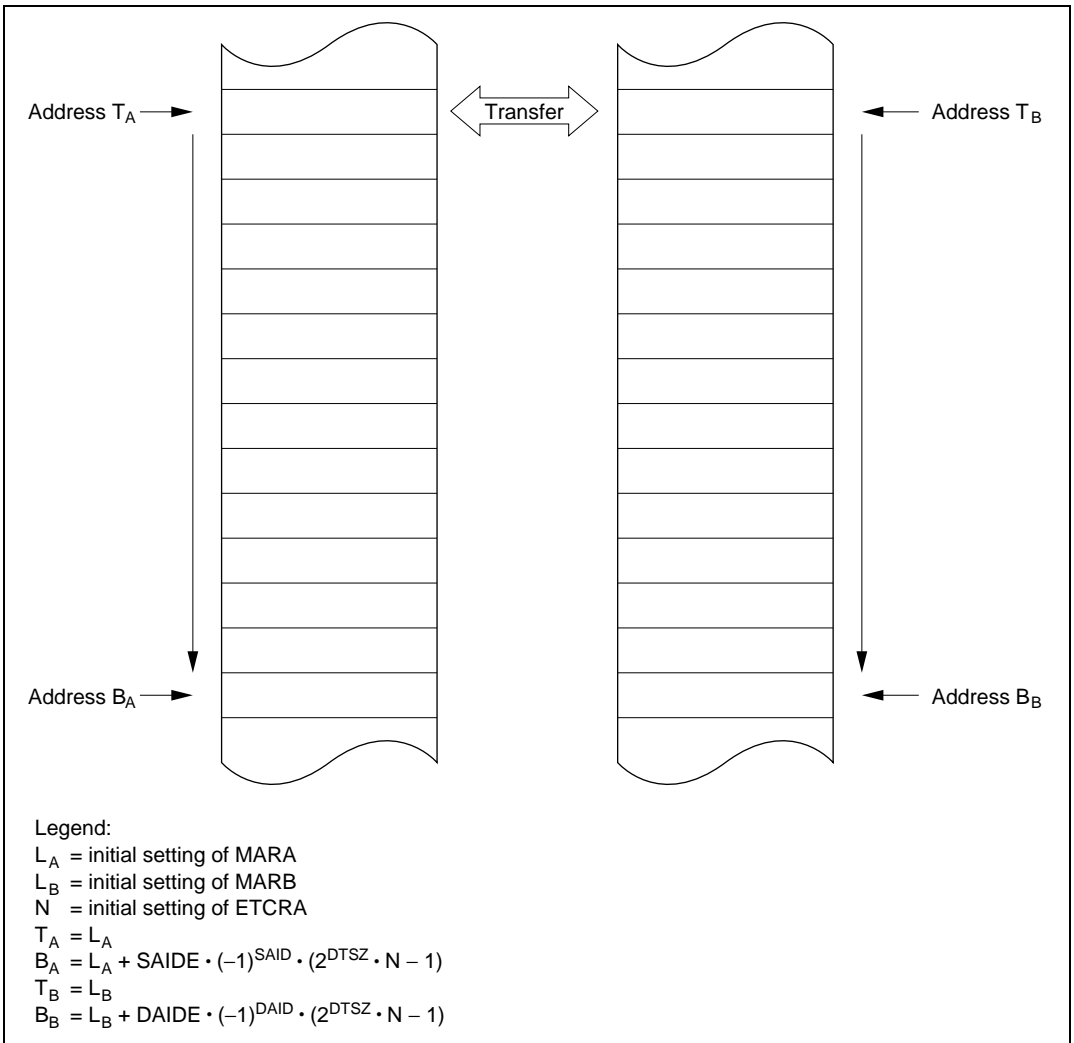

Figure 8.8 Operation in Normal Mode

Transfers can be requested (activated) by an external request or auto-request. An auto-requested transfer is activated by the register settings alone. The designated number of transfers are executed automatically. Either cycle-steal or burst mode can be selected. In cycle-steal mode the DMAC releases the bus temporarily after each transfer. In burst mode the DMAC keeps the bus until the transfers are completed, unless there is a bus request from a higher-priority bus master.

For the detailed settings see section 8.3.4, Data Transfer Control Registers (DTCR).

Figure 8.9 shows a sample setup procedure for normal mode.

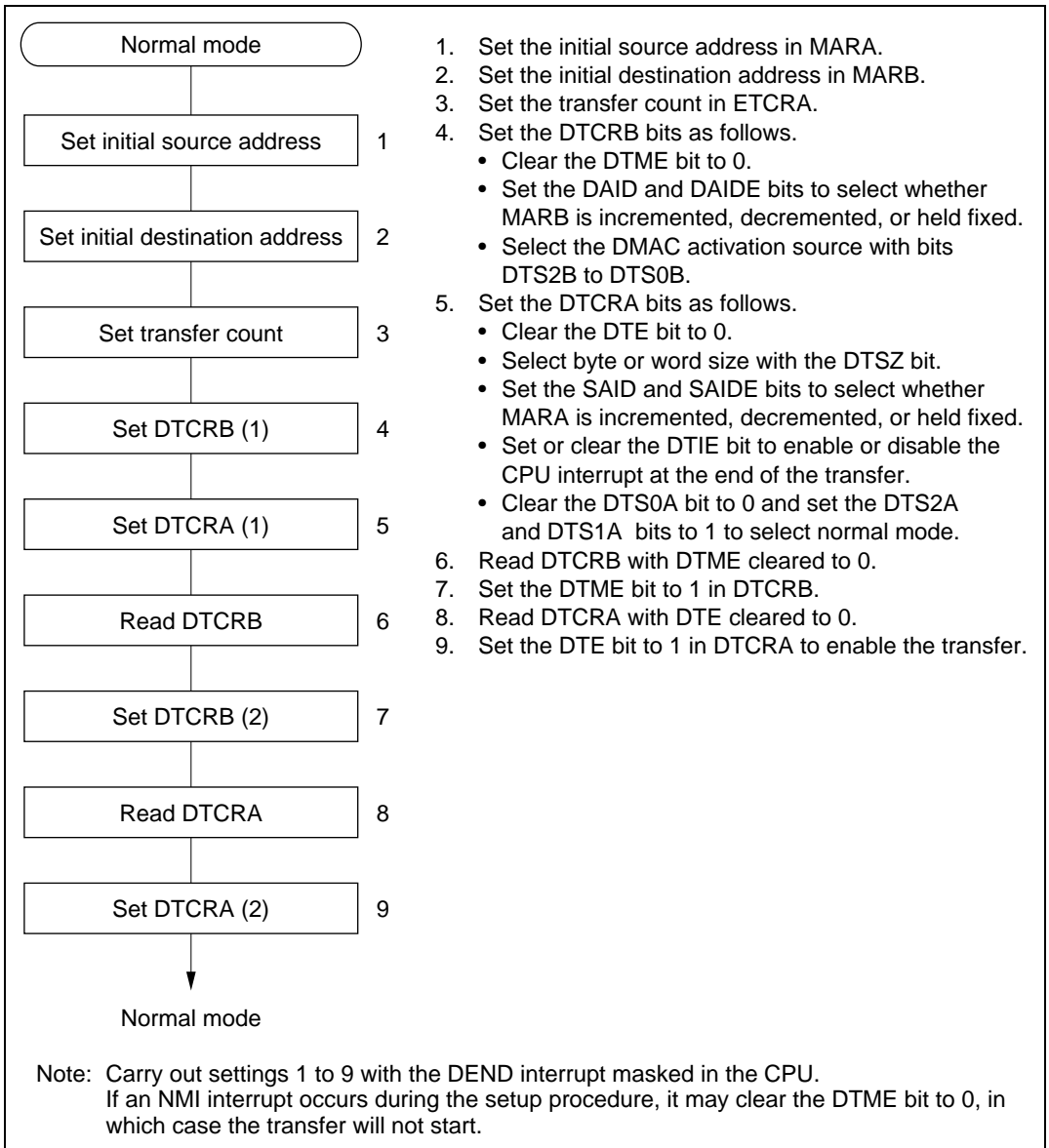

Figure 8.9 Normal Mode Setup Procedure (Example)

8.4.6 Block Transfer Mode

In block transfer mode the A and B channels are combined. One block of a specified size is transferred per request. A designated number of block transfers are executed. Addresses are specified in MARA and MARB. The block area address can be either held fixed or cycled.

Table 8.10 indicates the register functions in block transfer mode.

Table 8.10 Register Functions in Block Transfer Mode

Register	Function	Initial Setting	Operation
<div style="display: flex; justify-content: space-between;"> 23 0 </div> <div style="border: 1px solid black; padding: 5px; margin: 5px 0;"> <div style="display: flex; justify-content: space-between;"> MARA </div> </div>	Source address register	Source address	Incremented or decremented once per transfer, or held fixed
<div style="display: flex; justify-content: space-between;"> 23 0 </div> <div style="border: 1px solid black; padding: 5px; margin: 5px 0;"> <div style="display: flex; justify-content: space-between;"> MARB </div> </div>	Destination address register	Destination address	Incremented or decremented once per transfer, or held fixed
<div style="display: flex; justify-content: space-between;"> 7 0 </div> <div style="border: 1px solid black; padding: 5px; margin: 5px 0;"> <div style="display: flex; justify-content: space-between;"> ETCRAH </div> </div>	Block size counter	Block size	Decrementd once per transfer until H'00 is reached, then reloaded from ETCRAL
<div style="display: flex; justify-content: space-between;"> 7 0 </div> <div style="border: 1px solid black; padding: 5px; margin: 5px 0;"> <div style="display: flex; justify-content: space-between;"> ETCRAL </div> </div>	Initial block size	Block size	Held fixed
<div style="display: flex; justify-content: space-between;"> 15 0 </div> <div style="border: 1px solid black; padding: 5px; margin: 5px 0;"> <div style="display: flex; justify-content: space-between;"> ETCRB </div> </div>	Block transfer counter	Number of block transfers	Decrementd once per block transfer until H'0000 is reached and the transfer ends

Legend:

MARA: Memory address register A

MARB: Memory address register B

ETCRA: Execute transfer count register A

ETCRB: Execute transfer count register B

The source and destination addresses are both 24-bit addresses. MARA specifies the source address. MARB specifies the destination address. MARA and MARB can be independently incremented, decremented, or held fixed as data is transferred. One of these registers operates as a block area register: even if it is incremented or decremented, it is restored to its initial value at the end of each block transfer. The TMS bit in DTCRB selects whether the block area is the source or destination.

If M (1 to 255) is the size of the block transferred at each request and N (1 to 65,536) is the number of blocks to be transferred, then ETCRAH and ETCRAL should initially be set to M and ETCRB should initially be set to N .

Figure 8.10 illustrates how block transfer mode operates. In this figure, bit TMS is cleared to 0, meaning the block area is the destination.

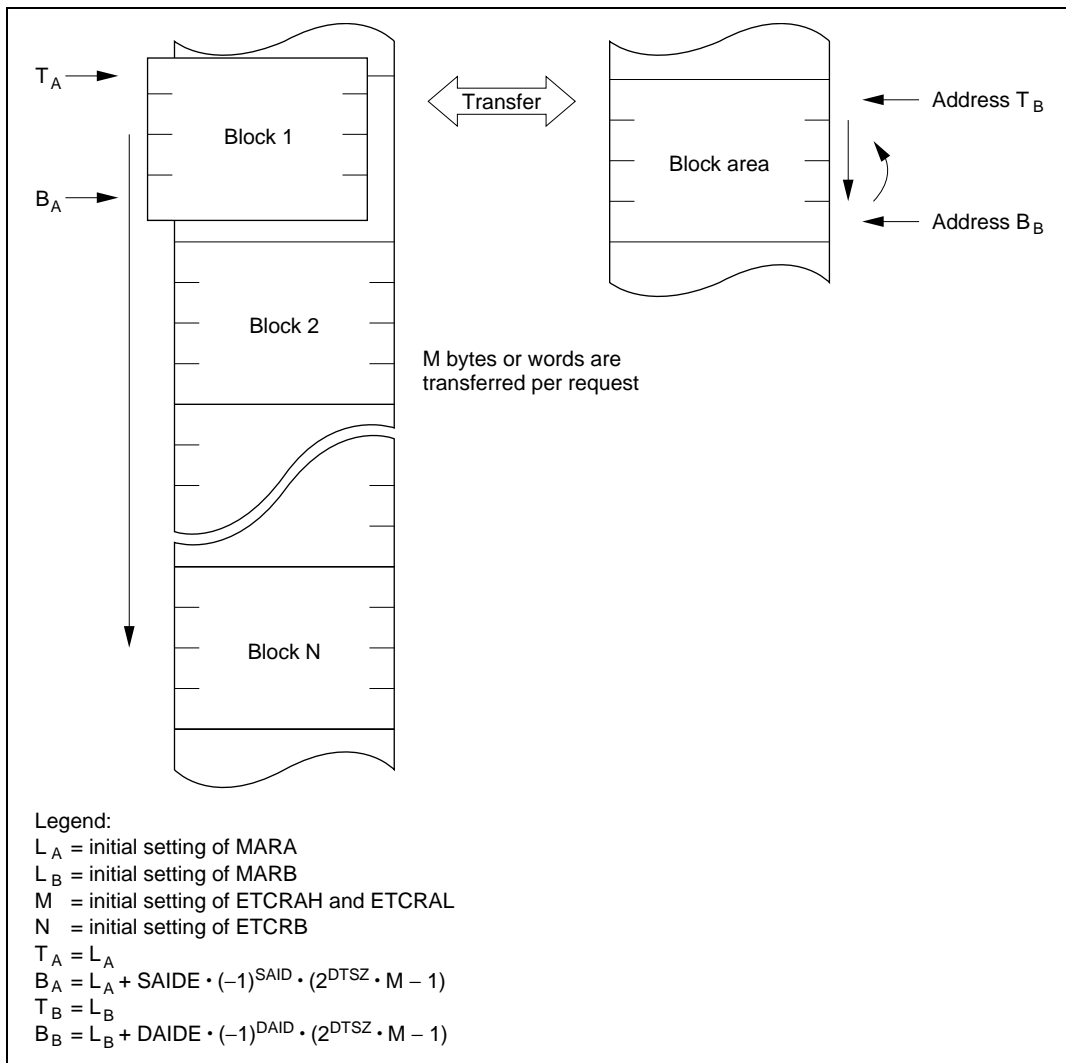

Figure 8.10 Operation in Block Transfer Mode

When activated by a transfer request, the DMAC executes a burst transfer. During the transfer MARA and MARB are updated according to the DTCR settings, and ETCRAH is decremented. When ETCRAH reaches H'00, it is reloaded from ETCRAL to restore the initial value. The memory address register of the block area is also restored to its initial value, and ETCRB is decremented. If ETCRB is not H'0000, the DMAC then waits for the next transfer request. ETCRAH and ETCRAL should be initially set to the same value.

The above operation is repeated until ETCRB reaches H'0000, at which point the DTE bit is cleared to 0 and the transfer ends. If the DTIE bit is set to 1, a CPU interrupt is requested at this time.

Figure 8.11 shows examples of a block transfer with byte data size when the block area is the destination. In (a) the block area address is cycled. In (b) the block area address is held fixed.

Transfers can be requested (activated) by compare match/input capture A interrupts from ITU channels 0 to 3, and by external request signals.

For the detailed settings see section 8.3.4, Data Transfer Control Registers (DTCR).

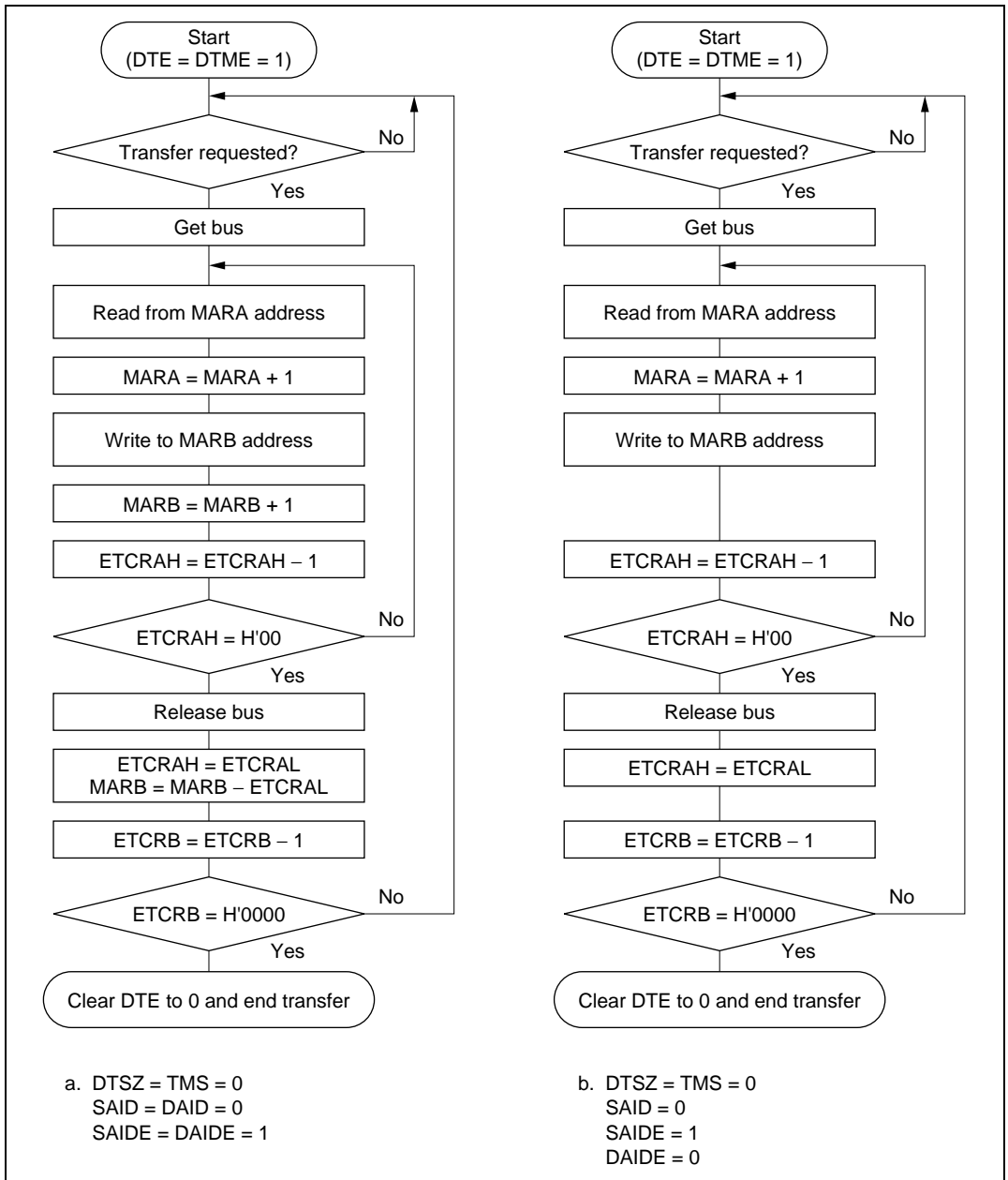

Figure 8.11 Block Transfer Mode Flowcharts (Examples)

Figure 8.12 shows a sample setup procedure for block transfer mode.

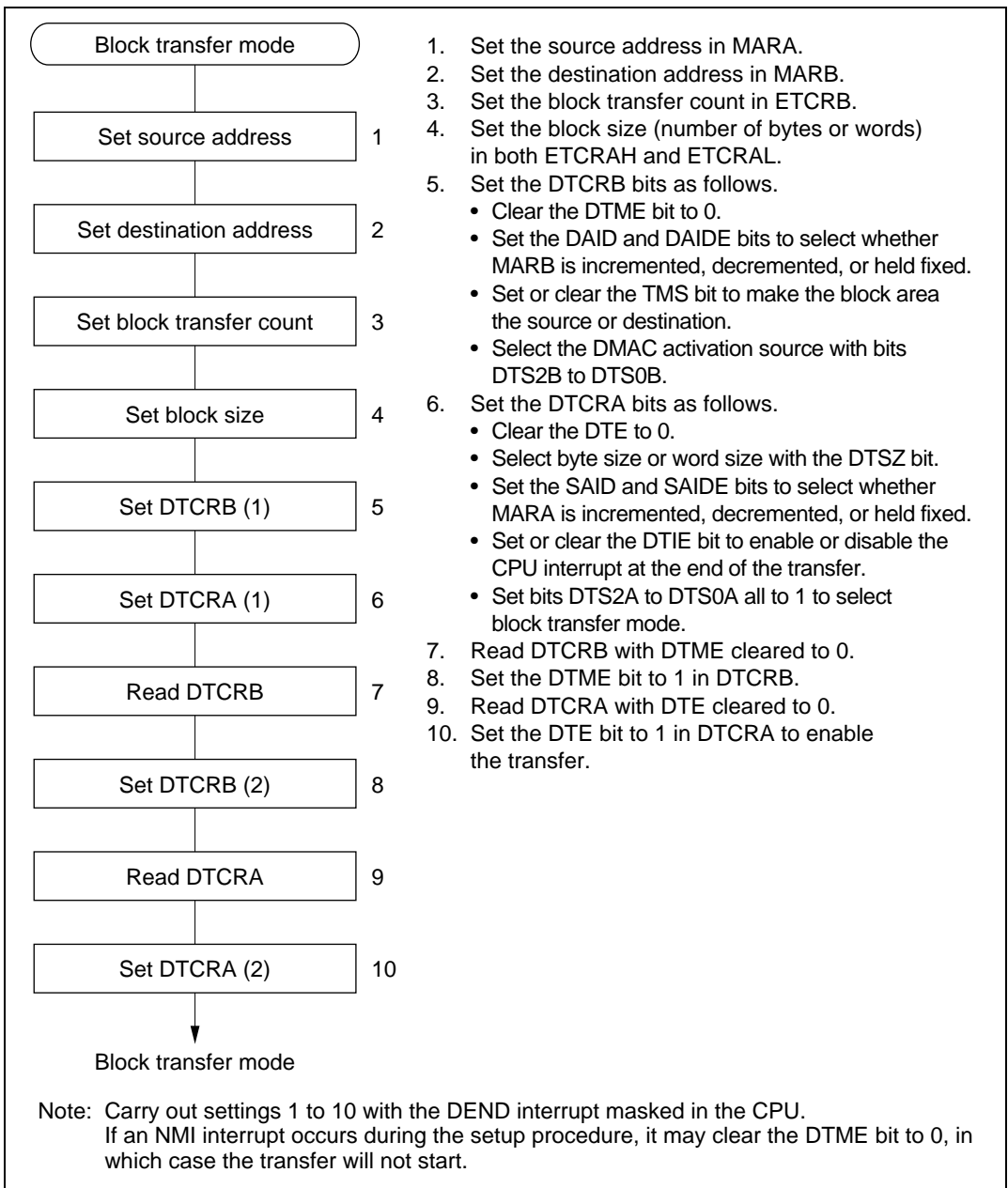

Figure 8.12 Block Transfer Mode Setup Procedure (Example)

8.4.7 DMAC Activation

The DMAC can be activated by an internal interrupt, external request, or auto-request. The available activation sources differ depending on the transfer mode and channel as indicated in table 8.11.

Table 8.11 DMAC Activation Sources

Activation Source		Short Address Mode		Full Address Mode	
		Channels 0A and 1A	Channels 0B and 1B	Normal	Block
Internal interrupts	IMIA0	Yes	Yes	No	Yes
	IMIA1	Yes	Yes	No	Yes
	IMIA2	Yes	Yes	No	Yes
	IMIA3	Yes	Yes	No	Yes
	TXI0	Yes	Yes	No	No
	RXI0	Yes	Yes	No	No
External requests	Falling edge of DREQ	No	Yes	Yes	Yes
	Low input at DREQ	No	Yes	Yes	No
Auto-request		No	No	Yes	No

Activation by Internal Interrupts

When an interrupt request is selected as a DMAC activation source and the DTE bit is set to 1, that interrupt request is not sent to the CPU. It is not possible for an interrupt request to activate the DMAC and simultaneously generate a CPU interrupt.

When the DMAC is activated by an interrupt request, the interrupt request flag is cleared automatically. If the same interrupt is selected to activate two or more channels, the interrupt request flag is cleared when the highest-priority channel is activated, but the transfer request is held pending on the other channels in the DMAC, which are activated in their priority order.

Activation by External Request

If an external request ($\overline{\text{DREQ}}$ pin) is selected as an activation source, the $\overline{\text{DREQ}}$ pin becomes an input pin and the corresponding $\overline{\text{TEND}}$ pin becomes an output pin, regardless of the port data direction register (DDR) settings. The $\overline{\text{DREQ}}$ input can be level-sensitive or edge-sensitive.

In short address mode and normal mode, an external request operates as follows. If edge sensing is selected, one byte or word is transferred each time a high-to-low transition of the $\overline{\text{DREQ}}$ input is detected. If the next edge is input before the transfer is completed, the next transfer may not be executed. If level sensing is selected, the transfer continues while $\overline{\text{DREQ}}$ is low, until the transfer is completed. The bus is released temporarily after each byte or word has been transferred, however. If the $\overline{\text{DREQ}}$ input goes high during a transfer, the transfer is suspended after the current byte or word has been transferred. When $\overline{\text{DREQ}}$ goes low, the request is held internally until one byte or word has been transferred. The $\overline{\text{TEND}}$ signal goes low during the last write cycle.

In block transfer mode, an external request operates as follows. Only edge-sensitive transfer requests are possible in block transfer mode. Each time a high-to-low transition of the $\overline{\text{DREQ}}$ input is detected, a block of the specified size is transferred. The $\overline{\text{TEND}}$ signal goes low during the last write cycle in each block.

Activation by Auto-Request

The transfer starts as soon as enabled by register setup, and continues until completed. Cycle-steal mode or burst mode can be selected.

In cycle-steal mode the DMAC releases the bus temporarily after transferring each byte or word. Normally, DMAC cycles alternate with CPU cycles.

In burst mode the DMAC keeps the bus until the transfer is completed, unless there is a higher-priority bus request. If there is a higher-priority bus request, the bus is released after the current byte or word has been transferred.

8.4.8 DMAC Bus Cycle

Figure 8.13 shows an example of the timing of the basic DMAC bus cycle. This example shows a word-size transfer from a 16-bit two-state access area to an 8-bit three-state access area. When the DMAC gets the bus from the CPU, after one dead cycle (T_d), it reads from the source address and writes to the destination address. During these read and write operations the bus is not released even if there is another bus request. DMAC cycles comply with bus controller settings in the same way as CPU cycles.

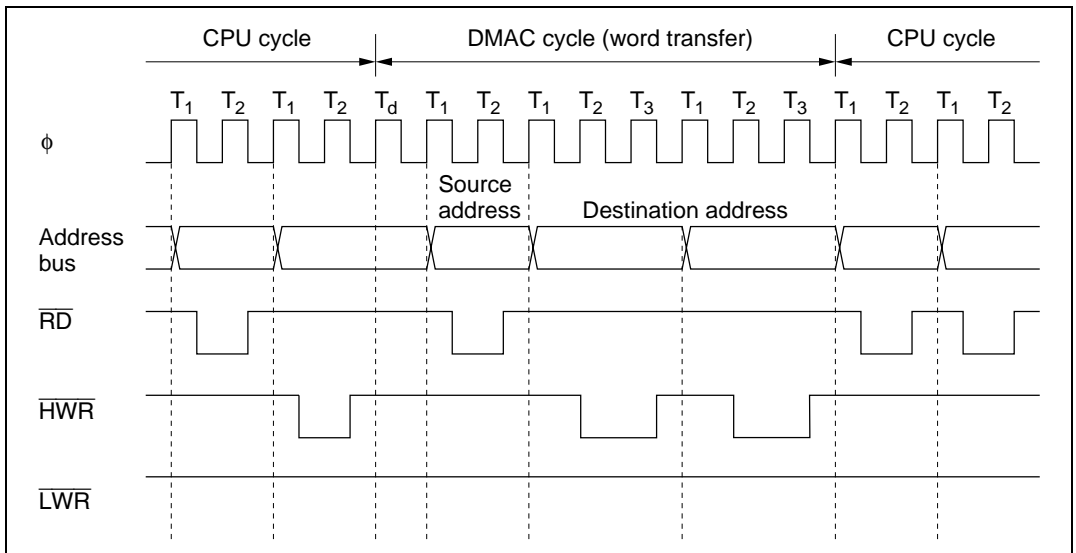

Figure 8.13 DMA Transfer Bus Timing (Example)

Figure 8.14 shows the timing when the DMAC is activated by low input at a $\overline{\text{DREQ}}$ pin. This example shows a word-size transfer from a 16-bit two-state access area to another 16-bit two-state access area. The DMAC continues the transfer while the $\overline{\text{DREQ}}$ pin is held low.

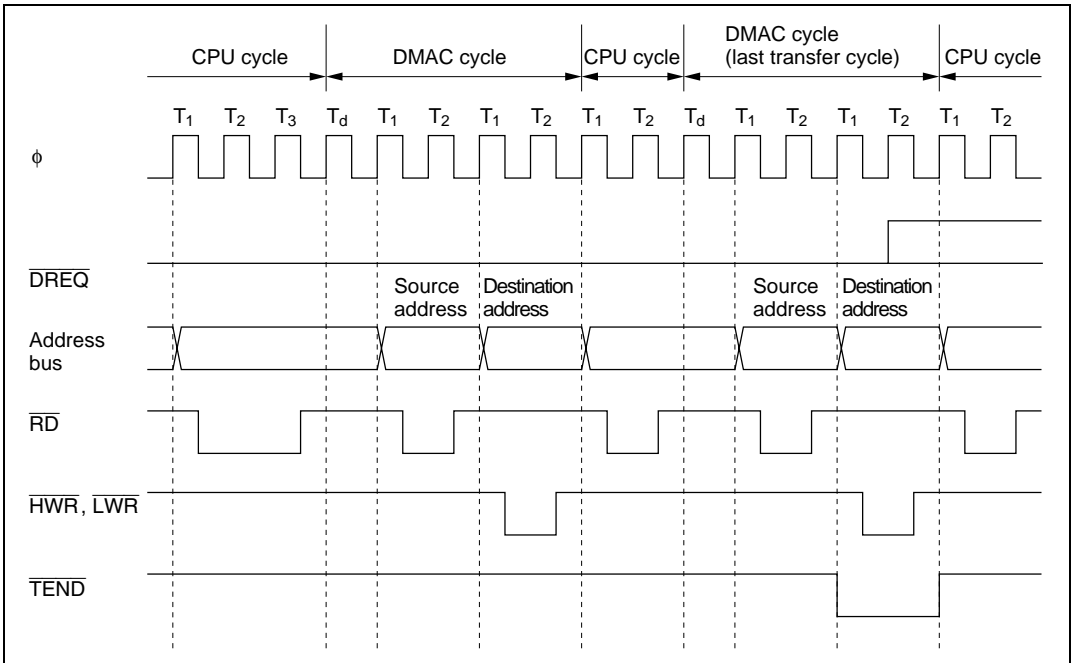

Figure 8.14 Bus Timing of DMA Transfer Requested by Low $\overline{\text{DREQ}}$ Input

Figure 8.15 shows an auto-requested burst-mode transfer. This example shows a transfer of three words from a 16-bit two-state access area to another 16-bit two-state access area.

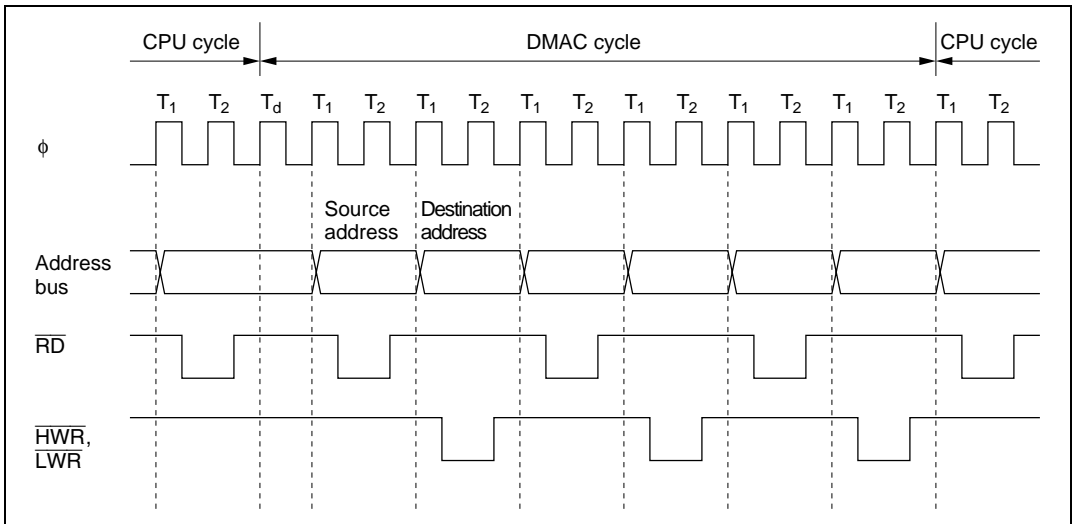

Figure 8.15 Bus Timing of Burst Mode DMA Transfer

When the DMAC is activated from a \overline{DREQ} pin there is a minimum interval of four states from when the transfer is requested until the DMAC starts operating. The \overline{DREQ} pin is not sampled during the time between the transfer request and the start of the transfer. In short address mode and normal mode, the pin is next sampled at the end of the read cycle. In block transfer mode, the pin is next sampled at the end of one block transfer.

Figure 8.17 shows the timing when the DMAC is activated by level-sensitive low $\overline{\text{DREQ}}$ input in normal mode.

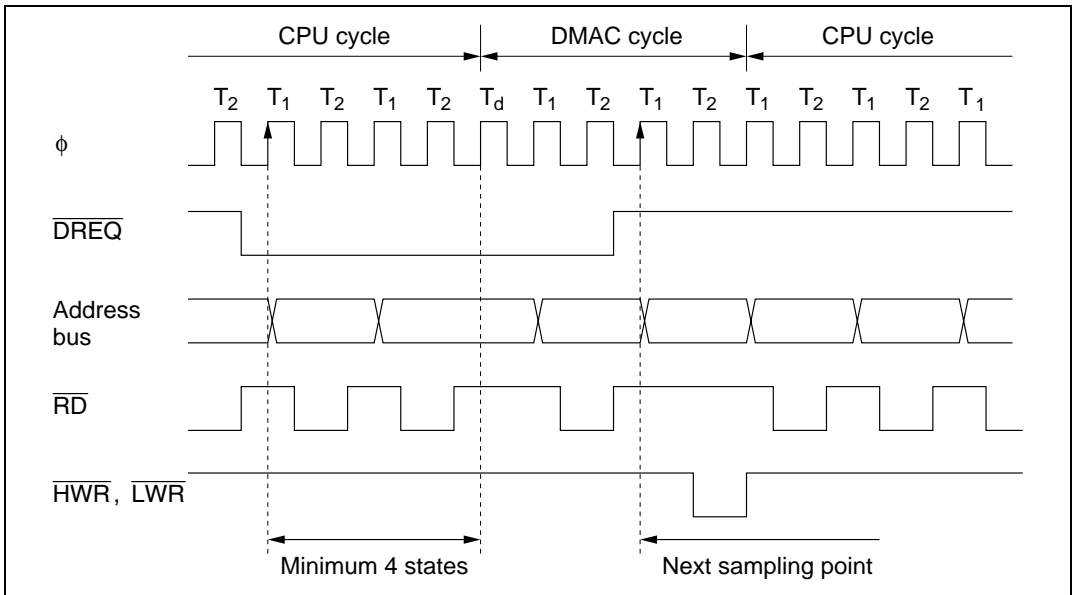

Figure 8.17 Timing of DMAC Activation by Low $\overline{\text{DREQ}}$ Level in Normal Mode

Figure 8.18 shows the timing when the DMAC is activated by the falling edge of $\overline{\text{DREQ}}$ in block transfer mode.

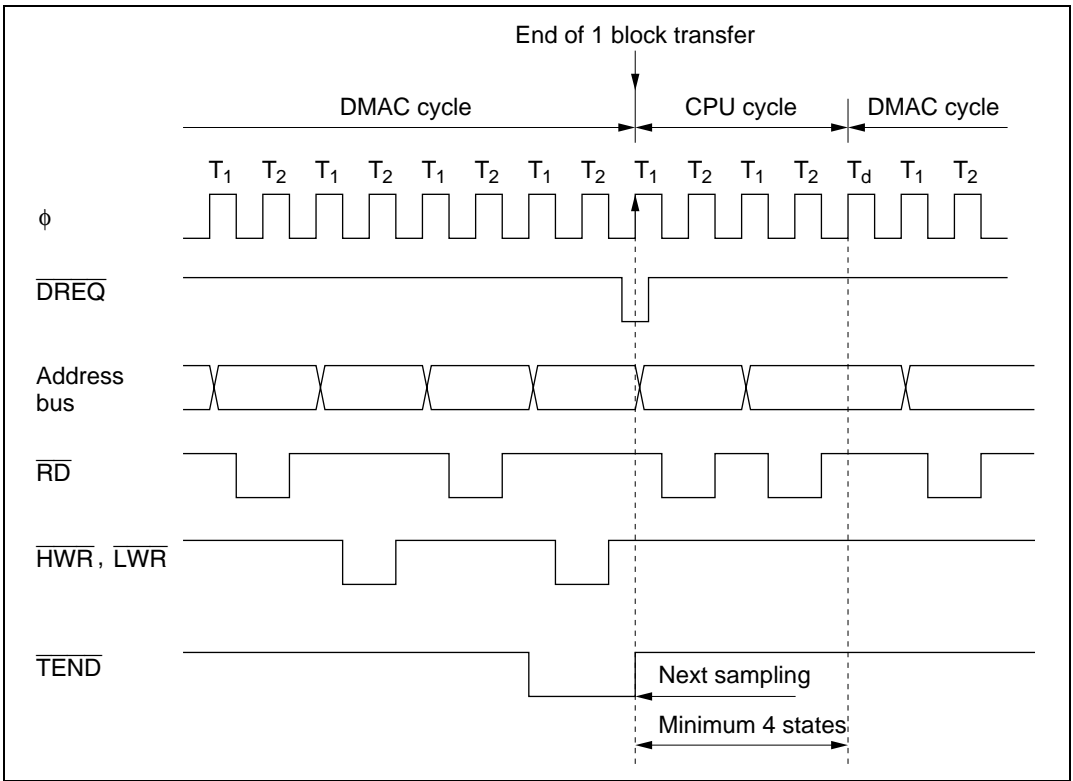

Figure 8.18 Timing of DMAC Activation by Falling Edge of $\overline{\text{DREQ}}$ in Block Transfer Mode

8.4.9 DMAC Multiple-Channel Operation

The DMAC channel priority order is: channel 0 > channel 1 and channel A > channel B.

Table 8.12 shows the complete priority order.

Table 8.12 Channel Priority Order

Short Address Mode	Full Address Mode	Priority
Channel 0A	Channel 0	High
Channel 0B		
Channel 1A	Channel 1	Low
Channel 1B		

If transfers are requested on two or more channels simultaneously, or if a transfer on one channel is requested during a transfer on another channel, the DMAC operates as follows.

1. When a transfer is requested, the DMAC requests the bus right. When it gets the bus right, it starts a transfer on the highest-priority channel at that time.
2. Once a transfer starts on one channel, requests to other channels are held pending until that channel releases the bus.
3. After each transfer in short address mode, and each externally-requested or cycle-steal transfer in normal mode, the DMAC releases the bus and returns to step 1. After releasing the bus, if there is a transfer request for another channel, the DMAC requests the bus again.
4. After completion of a burst-mode transfer, or after transfer of one block in block transfer mode, the DMAC releases the bus and returns to step 1. If there is a transfer request for a higher-priority channel or a bus request from a higher-priority bus master, however, the DMAC releases the bus after completing the transfer of the current byte or word. After releasing the bus, if there is a transfer request for another channel, the DMAC requests the bus again.

Figure 8.19 shows the timing when channel 0A is set up for I/O mode and channel 1 for burst mode, and a transfer request for channel 0A is received while channel 1 is active.

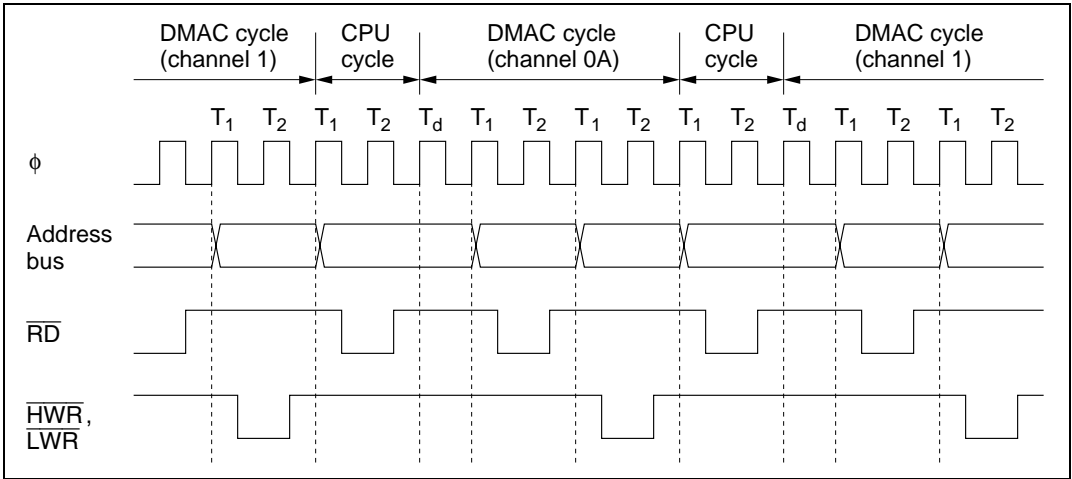

Figure 8.19 Timing of Multiple-Channel Operations

8.4.10 External Bus Requests, Refresh Controller, and DMAC

During a DMA transfer, if the bus right is requested by an external bus request signal (\overline{BREQ}) or by the refresh controller, the DMAC releases the bus after completing the transfer of the current byte or word. If there is a transfer request at this point, the DMAC requests the bus right again. Figure 8.20 shows an example of the timing of insertion of a refresh cycle during a burst transfer on channel 0.

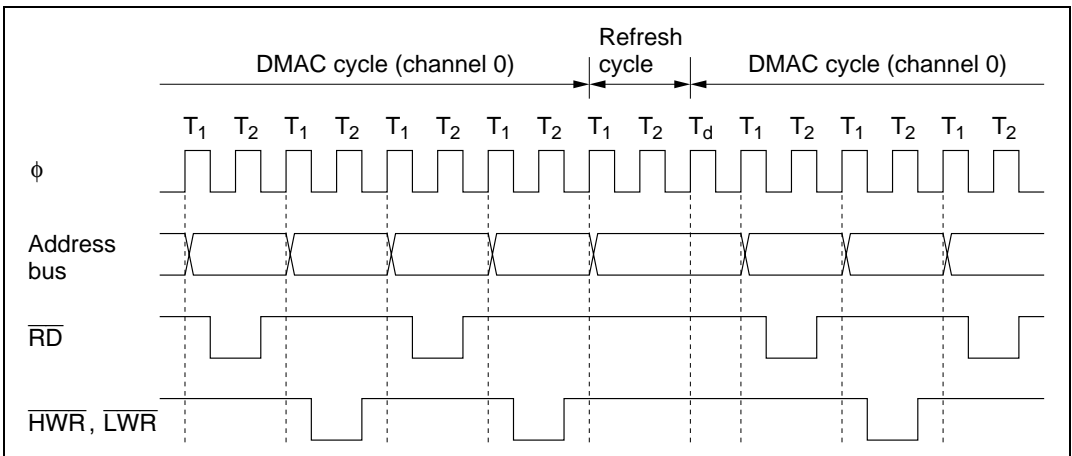

Figure 8.20 Bus Timing of Refresh Controller and DMAC

8.4.11 NMI Interrupts and DMAC

NMI interrupts do not affect DMAC operations in short address mode.

If an NMI interrupt occurs during a transfer in full address mode, the DMAC suspends operations. In full address mode, a channel is enabled when its DTE and DTME bits are both set to 1. NMI input clears the DTME bit to 0. After transferring the current byte or word, the DMAC releases the bus to the CPU. In normal mode, the suspended transfer resumes when the CPU sets the DTME bit to 1 again. Check that the DTE bit is set to 1 and the DTME bit is cleared to 0 before setting the DTME bit to 1.

Figure 8.21 shows the procedure for resuming a DMA transfer in normal mode on channel 0 after the transfer was halted by NMI input.

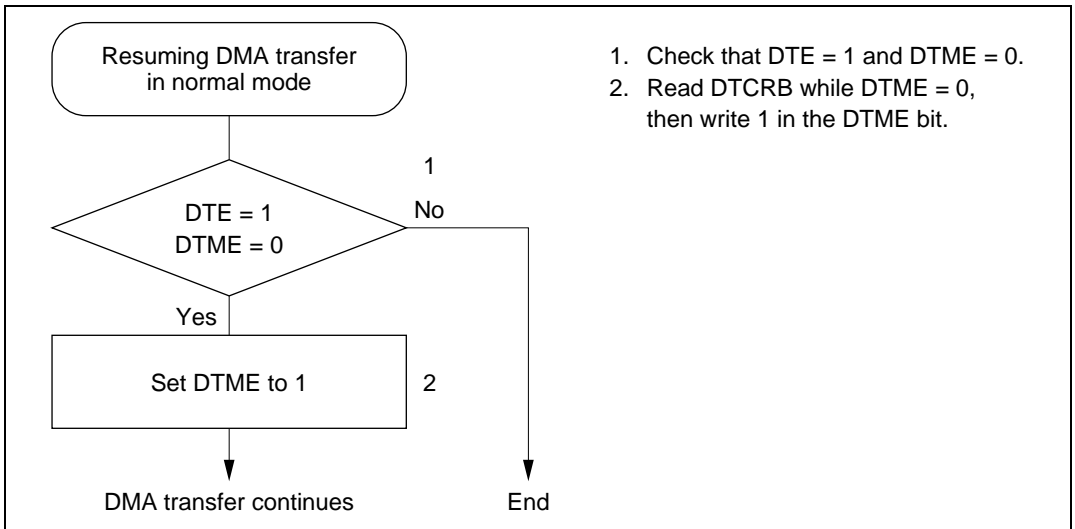

Figure 8.21 Procedure for Resuming a DMA Transfer Halted by NMI (Example)

For information about NMI interrupts in block transfer mode, see section 8.6.6, NMI Interrupts and Block Transfer Mode.

8.4.12 Aborting a DMA Transfer

When the DTE bit in an active channel is cleared to 0, the DMAC halts after transferring the current byte or word. The DMAC starts again when the DTE bit is set to 1. In full address mode, the DTME bit can be used for the same purpose. Figure 8.22 shows the procedure for aborting a DMA transfer by software.

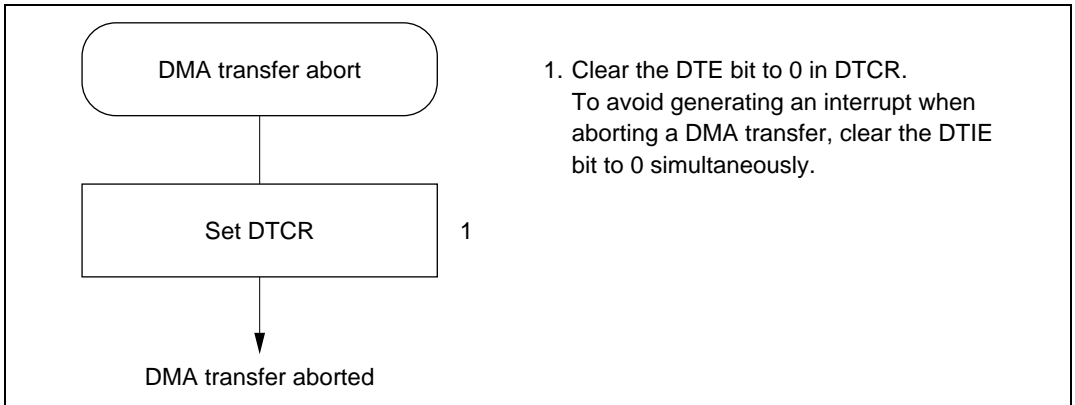

Figure 8.22 Procedure for Aborting a DMA Transfer

8.4.13 Exiting Full Address Mode

Figure 8.23 shows the procedure for exiting full address mode and initializing the pair of channels. To set the channels up in another mode after exiting full address mode, follow the setup procedure for the relevant mode.

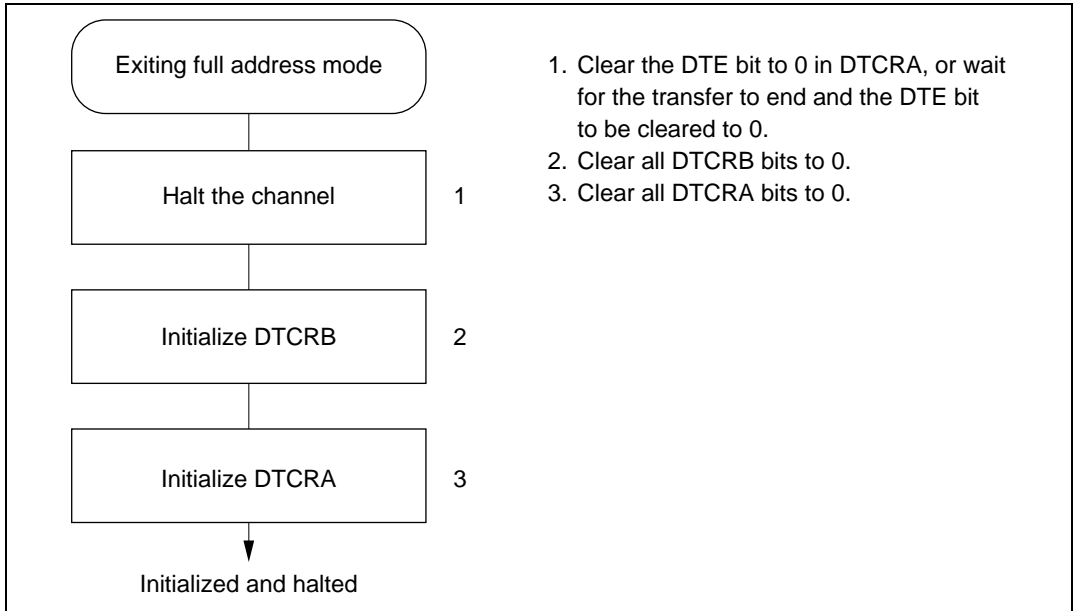

Figure 8.23 Procedure for Exiting Full Address Mode (Example)

8.4.14 DMAC States in Reset State, Standby Modes, and Sleep Mode

When the chip is reset or enters hardware or software standby mode, the DMAC is initialized and halts. DMAC operations continue in sleep mode. Figure 8.24 shows the timing of a cycle-steal transfer in sleep mode.

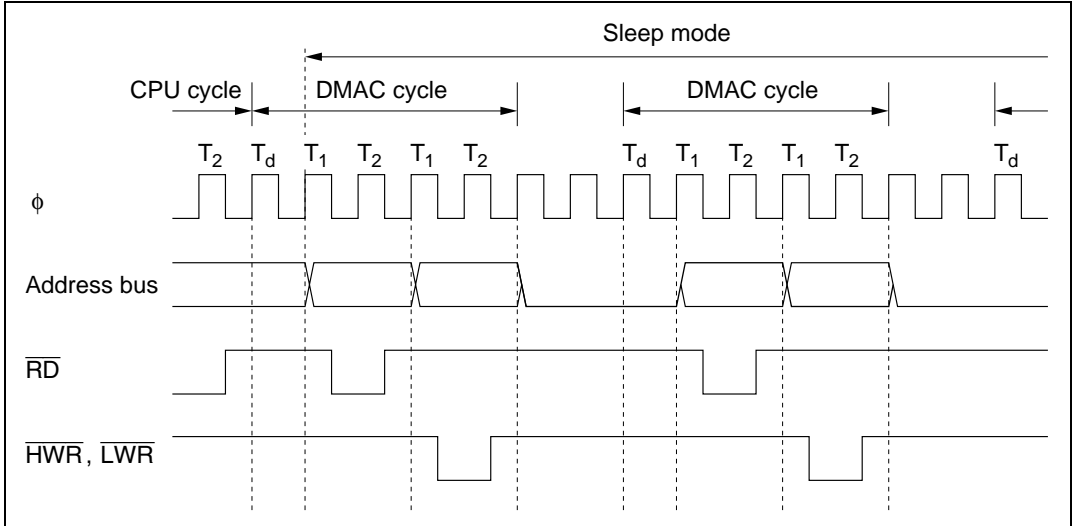

Figure 8.24 Timing of Cycle-Steal Transfer in Sleep Mode

8.5 Interrupts

The DMAC generates only DMA-end interrupts. Table 8.13 lists the interrupts and their priority.

Table 8.13 DMAC Interrupts

Interrupt	Description		Interrupt Priority
	Short Address Mode	Full Address Mode	
DEND0A	End of transfer on channel 0A	End of transfer on channel 0	High
DEND0B	End of transfer on channel 0B	—	↑
DEND1A	End of transfer on channel 1A	End of transfer on channel 1	
DEND1B	End of transfer on channel 1B	—	Low

Each interrupt is enabled or disabled by the DTIE bit in the corresponding data transfer control register (DTCR). Separate interrupt signals are sent to the interrupt controller.

The interrupt priority order among channels is channel 0 > channel 1 and channel A > channel B.

Figure 8.25 shows the DMA-end interrupt logic. An interrupt is requested whenever DTE = 0 and DTIE = 1.

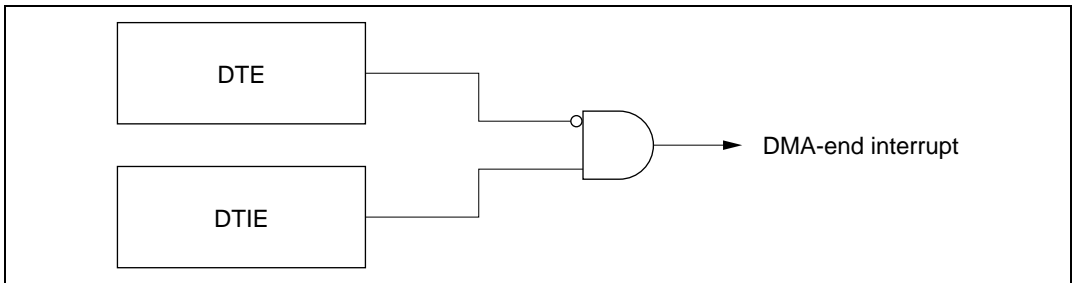

Figure 8.25 DMA-End Interrupt Logic

The DMA-end interrupt for the B channels (DENDB) is unavailable in full address mode. The DTME bit does not affect interrupt operations.

8.6 Usage Notes

8.6.1 Note on Word Data Transfer

Word data cannot be accessed starting at an odd address. When word-size transfer is selected, set even values in the memory and I/O address registers (MAR and IOAR).

8.6.2 DMAC Self-Access

The DMAC itself cannot be accessed during a DMAC cycle. DMAC registers cannot be specified as source or destination addresses.

8.6.3 Longword Access to Memory Address Registers

A memory address register can be accessed as longword data at the MARR address.

Example:

```
MOV.L #LBL, ERO
MOV.L ERO, @MARR
```

Four byte accesses are performed. Note that the CPU may release the bus between the second byte (MARE) and third byte (MARH).

Memory address registers should be written and read only when the DMAC is halted.

8.6.4 Note on Full Address Mode Setup

Full address mode is controlled by two registers: DTCRA and DTCRB. Care must be taken to prevent the B channel from operating in short address mode during the register setup. The enable bits (DTE and DTME) should not be set to 1 until the end of the setup procedure.

8.6.5 Note on Activating DMAC by Internal Interrupts

When using an internal interrupt to activate the DMAC, make sure that the interrupt selected as the activating source does not occur during the interval after it has been selected but before the DMAC has been enabled. The on-chip supporting module that will generate the interrupt should not be activated until the DMAC has been enabled. If the DMAC must be enabled while the on-chip supporting module is active, follow the procedure in figure 8.26.

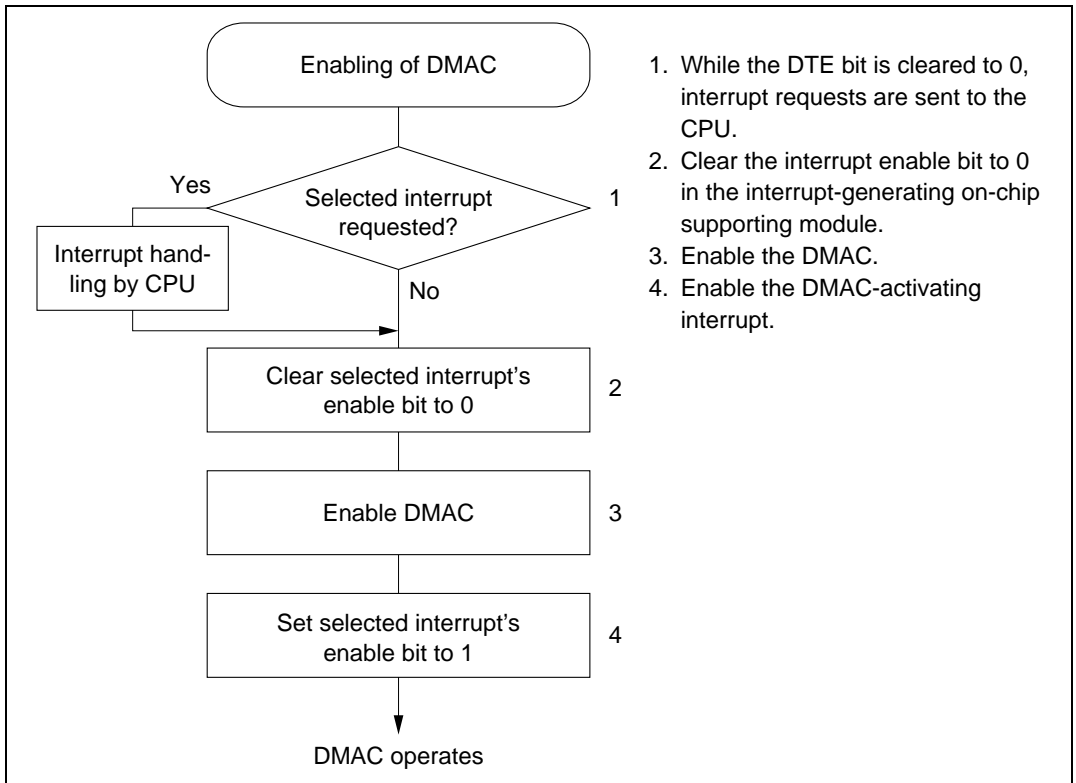

Figure 8.26 Procedure for Enabling DMAC while On-Chip Supporting Module Is Operating (Example)

If the DTE bit is set to 1 but the DTME bit is cleared to 0, the DMAC is halted and the selected activating source cannot generate a CPU interrupt. If the DMAC is halted by an NMI interrupt, for example, the selected activating source cannot generate CPU interrupts. To terminate DMAC operations in this state, clear the DTE bit to 0 to allow CPU interrupts to be requested. To continue DMAC operations, carry out steps 2 and 4 in figure 8.26 before and after setting the DTME bit to 1.

When an ITU interrupt activates the DMAC, make sure the next interrupt does not occur before the DMA transfer ends. If one ITU interrupt activates two or more channels, make sure the next interrupt does not occur before the DMA transfers end on all the activated channels. If the next interrupt occurs before a transfer ends, the channel or channels for which that interrupt was selected may fail to accept further activation requests.

8.6.6 NMI Interrupts and Block Transfer Mode

If an NMI interrupt occurs in block transfer mode, the DMAC operates as follows.

1. When the NMI interrupt occurs, the DMAC finishes transferring the current byte or word, then clears the DTME bit to 0 and halts. The halt may occur in the middle of a block.
It is possible to find whether a transfer was halted in the middle of a block by checking the block size counter. If the block size counter does not have its initial value, the transfer was halted in the middle of a block.
2. If the transfer is halted in the middle of a block, the activating interrupt flag is cleared to 0. The activation request is not held pending.
3. While the DTE bit is set to 1 and the DTME bit is cleared to 0, the DMAC is halted and does not accept activating interrupt requests. If an activating interrupt occurs in this state, the DMAC does not operate and does not hold the transfer request pending internally. Neither is a CPU interrupt requested.
For this reason, before setting the DTME bit to 1, first clear the enable bit of the activating interrupt to 0. Then, after setting the DTME bit to 1, set the interrupt enable bit to 1 again. See section 8.6.5, Note on Activating DMAC by Internal Interrupts.
4. When the DTME bit is set to 1, the DMAC waits for the next transfer request. If it was halted in the middle of a block transfer, the rest of the block is transferred when the next transfer request occurs. Otherwise, the next block is transferred when the next transfer request occurs.

8.6.7 Memory and I/O Address Register Values

Table 8.14 indicates the address ranges that can be specified in the memory and I/O address registers (MAR and IOAR).

Table 8.14 Address Ranges Specifiable in MAR and IOAR

	1-Mbyte Mode	16-Mbyte Mode
MAR	H'00000 to H'FFFFFF (0 to 1048575)	H'000000 to H'FFFFFF (0 to 16777215)
IOAR	H'FFF00 to H'FFFFFF (1048320 to 1048575)	H'FFFF00 to H'FFFFFF (16776960 to 16777215)

MAR bits 23 to 20 are ignored in 1-Mbyte mode.

8.6.8 Bus Cycle when Transfer Is Aborted

When a transfer is aborted by clearing the DTE bit or suspended by an NMI that clears the DTME bit, if this halts a channel for which the DMAC has a transfer request pending internally, a dead cycle may occur. This dead cycle does not update the halted channel's address register or counter value. Figure 8.27 shows an example in which an auto-requested transfer in cycle-steal mode on channel 0 is aborted by clearing the DTE bit in channel 0.

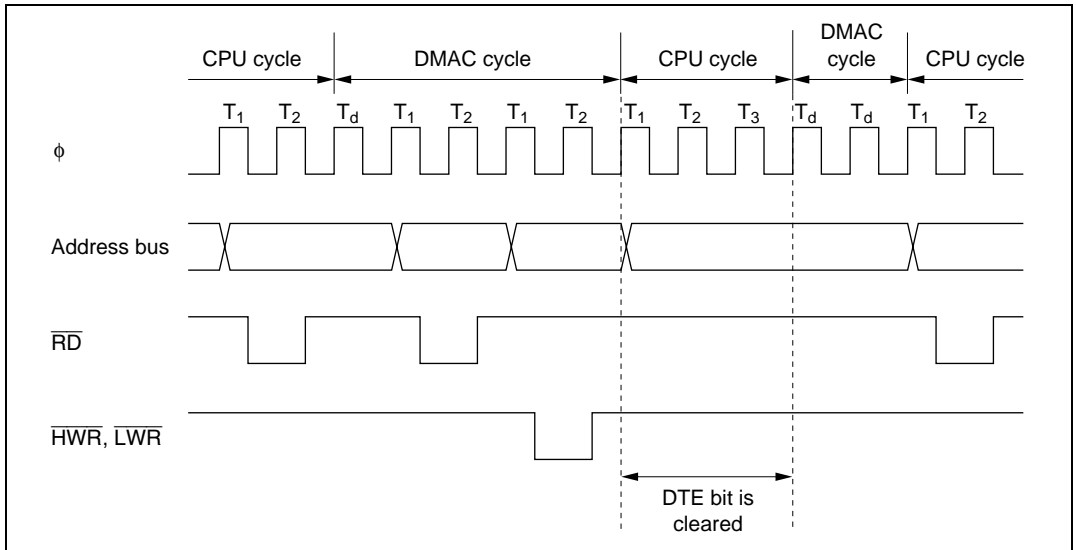

Figure 8.27 Bus Timing at Abort of DMA Transfer in Cycle-Steal Mode

Section 9 I/O Ports

9.1 Overview

The H8/3048B Group has 10 input/output ports (ports 1, 2, 3, 4, 5, 6, 8, 9, A, and B) and one input port (port 7). Table 9.1 summarizes the port functions. The pins in each port are multiplexed as shown in table 9.1.

Each port has a data direction register (DDR) for selecting input or output, and a data register (DR) for storing output data. In addition to these registers, ports 2, 4, and 5 have an input pull-up MOS control register (PCR) for switching input pull-up MOS transistors on and off.

Ports 1 to 6 and port 8 can drive one TTL load and a 90-pF capacitive load. Ports 9, A, and B can drive one TTL load and a 30-pF capacitive load. Ports 1 to 6 and 8 to B can drive a darlington pair. Ports 1, 2, 5, and B can drive LEDs (with 10-mA current sink). Pins P8₂ to P8₀, PA₇ to PA₀, and PB₃ to PB₀ have Schmitt-trigger input circuits.

For block diagrams of the ports see appendix C, I/O Port Block Diagrams.

Table 9.1 Port Functions

Port	Description	Pins	Mode 1	Mode 2	Mode 3	Mode 4	Mode 5	Mode 6	Mode 7
Port 1	<ul style="list-style-type: none"> 8-bit I/O port Can drive LEDs 	P1 ₇ to P1 ₀ / A ₇ to A ₀	Address output pins (A ₇ to A ₀)				Address output (A ₇ to A ₀) and generic input DDR = 0: generic input DDR = 1: address output	Generic input/output	
Port 2	<ul style="list-style-type: none"> 8-bit I/O port Input pull-up MOS Can drive LEDs 	P2 ₇ to P2 ₀ / A ₁₅ to A ₈	Address output pins (A ₁₅ to A ₈)				Address output (A ₁₅ to A ₈) and generic input DDR = 0: generic input DDR = 1: address output	Generic input/output	
Port 3	<ul style="list-style-type: none"> 8-bit I/O port 	P3 ₇ to P3 ₀ / D ₁₅ to D ₈	Data input/output (D ₁₅ to D ₈)						Generic input/output
Port 4	<ul style="list-style-type: none"> 8-bit I/O port Input pull-up MOS 	P4 ₇ to P4 ₀ / D ₇ to D ₀	Data input/output (D ₇ to D ₀) and 8-bit generic input/output 8-bit bus mode: generic input/output 16-bit bus mode: data input/output						Generic input/output
Port 5	<ul style="list-style-type: none"> 4-bit I/O port Input pull-up MOS Can drive LEDs 	P5 ₃ to P5 ₀ / A ₁₉ to A ₁₆	Address output (A ₁₉ to A ₁₆)				Address output (A ₁₉ to A ₁₆) and 4-bit generic input DDR = 0: generic input DDR = 1: address output	Generic input/output	
Port 6	<ul style="list-style-type: none"> 7-bit I/O port 	P6 ₇ /LWR, P6 ₆ /HWR, P6 ₅ /RD, P6 ₄ /AS	Bus control signal output (LWR, HWR, RD, AS)						Generic input/output
		P6 ₃ /BACK, P6 ₂ /BREQ, P6 ₁ /WAIT	Bus control signal input/output (BACK, BREQ, WAIT) and 3-bit generic input/output						
Port 7	<ul style="list-style-type: none"> 8-bit I/O port 	P7 ₇ /AN ₇ /DA ₁ , P7 ₆ /AN ₆ /DA ₀	Analog input (AN ₇ , AN ₆) to A/D converter, analog output (DA ₁ , DA ₀) from D/A converter, and generic input						
		P7 ₅ to P7 ₀ / AN ₅ to AN ₀	Analog input (AN ₅ to AN ₀) to A/D converter, and generic input						

Port	Description	Pins	Mode 1	Mode 2	Mode 3	Mode 4	Mode 5	Mode 6	Mode 7
Port 8	<ul style="list-style-type: none"> 5-bit I/O port P8₂ to P8₀ have Schmitt inputs 	P8 ₄ / \overline{CS}_0	DDR = 0: generic input DDR = 1 (after reset): \overline{CS}_0 output						Generic input/output
		P8 ₃ / \overline{CS}_4 / \overline{IRQ}_3 , P8 ₂ / \overline{CS}_2 / \overline{IRQ}_2 , P8 ₁ / \overline{CS}_3 / \overline{IRQ}_1	\overline{IRQ}_3 to \overline{IRQ}_1 input, \overline{CS}_1 to \overline{CS}_3 output, and generic input DDR = 0 (after reset): generic input DDR = 1: \overline{CS}_1 to \overline{CS}_3 output						\overline{IRQ}_3 to \overline{IRQ}_0 input and generic input/output
		P8 ₀ / \overline{RFSH} / \overline{IRQ}_0	\overline{IRQ}_0 input, \overline{RFSH} output, and generic input/output						input/output
Port 9	6-bit I/O port	P9 ₅ / \overline{SCK} / \overline{IRQ}_5 , P9 ₄ / \overline{SCK}_0 / \overline{IRQ}_4 , P9 ₃ / \overline{RxD}_1 , P9 ₂ / \overline{RxD}_0 , P9 ₁ / \overline{TxD}_1 , P9 ₀ / \overline{TxD}_0	Input and output (\overline{SCK}_1 , \overline{SCK}_0 , \overline{RxD}_1 , \overline{RxD}_0 , \overline{TxD}_1 , \overline{TxD}_0) for serial communication interfaces 1 and 0 (SCI1/0), \overline{IRQ}_5 and \overline{IRQ}_4 input, and 6-bit generic input/output						
Port A	<ul style="list-style-type: none"> 8-bit I/O port Schmitt inputs 	PA ₇ / \overline{TP}_7 / TIOCB ₂ / A_{20}	Output (\overline{TP}_7) from programmable timing pattern controller (TPC), input or output (TIOCB ₂) for 16-bit integrated timer unit (ITU), and generic input/output	Address output (A_{20})		TPC output (\overline{TP}_7), ITU input or output (TIOCB ₂), and generic input/output	Address output (A_{20})	TPC output (\overline{TP}_7), ITU input or output (TIOCB ₂), and generic input/output	
		PA ₆ / \overline{TP}_6 / TIOCA ₂ / A_{21} / \overline{CS}_4 , PA ₅ / \overline{TP}_5 / TIOCB ₁ / A_{22} / \overline{CS}_5 , PA ₄ / \overline{TP}_4 / TIOCA ₁ / A_{23} / \overline{CS}_6	TPC output (\overline{TP}_6 to \overline{TP}_4), ITU input and output (TIOCA ₂ , TIOCB ₁ , TIOCA ₁), \overline{CS}_4 to \overline{CS}_6 output, and generic input/output	TPC output (\overline{TP}_6 to \overline{TP}_4), ITU input and output (TIOCA ₂ , TIOCB ₁ , TIOCA ₁), address output (A_{23} to A_{21}), \overline{CS}_4 to \overline{CS}_6 output, and generic input/output		TPC output (\overline{TP}_6 to \overline{TP}_4), ITU input and output (TIOCA ₂ , TIOCB ₁ , TIOCA ₁), \overline{CS}_4 to \overline{CS}_6 output, and generic input/output	TPC output (\overline{TP}_6 to \overline{TP}_4), ITU input and output (TIOCA ₂ , TIOCB ₁ , TIOCA ₁), address output (A_{23} to A_{21}), \overline{CS}_4 to \overline{CS}_6 output, and generic input/output	TPC output (\overline{TP}_6 to \overline{TP}_4), ITU input and output (TIOCA ₂ , TIOCB ₁ , TIOCA ₁), and generic input/output	

Port	Description	Pins	Mode 1	Mode 2	Mode 3	Mode 4	Mode 5	Mode 6	Mode 7
Port A	<ul style="list-style-type: none"> 8-bit I/O port Schmitt inputs 	PA ₃ /TP ₃ / TIOCB ₀ / TCLKD, PA ₂ /TP ₂ / TIOCA ₀ / TCLKC, PA ₁ /TP ₁ / TEND/TCLKB, PA ₀ /TP ₀ / TEND/TCLKA	TPC output (TP ₃ to TP ₀), output (TEND ₁ , TEND ₀) from DMA controller (DMAC), ITU input and output (TCLKD, TCLKC, TCLKB, TCLKA, TIOCB ₀ , TIOCA ₀), and generic input/output						
Port B	<ul style="list-style-type: none"> 8-bit I/O port Can drive LEDs PB₃ to PB₀ have Schmitt inputs 	PB ₁₅ /TP ₁₅ / DREQ ₀ /ADTRG	TPC output (TP ₁₅), DMAC input (DREQ ₁), trigger input (ADTRG) to A/D converter, and generic input/output						
		PB ₁₄ /TP ₁₄ / DREQ ₀ /CS ₇	TPC output (TP ₁₄), DMAC input (DREQ ₀), CS ₇ output, and generic input/output						TPC output (TP ₁₄), DMAC input (DREQ ₀), and generic input/output
		PB ₁₃ /TP ₁₃ / TOCXB ₃ , PB ₁₂ /TP ₁₂ / TOCXA ₃ , PB ₁₁ /TP ₁₁ / TIOCB ₄ , PB ₁₀ /TP ₁₀ / TIOCA ₄ , PB ₉ /TP ₉ / TIOCB ₃ , PB ₈ /TP ₈ / TIOCA ₃	TPC output (TP ₁₃ to TP ₈), ITU input and output (TOCXB ₄ , TOCXA ₄ , TIOCB ₄ , TIOCA ₄ , TIOCB ₃ , TIOCA ₃), and generic input/output						

9.2 Port 1

9.2.1 Overview

Port 1 is an 8-bit input/output port with the pin configuration shown in figure 9.1. The pin functions differ between the expanded modes with on-chip ROM disabled, expanded modes with on-chip ROM enabled, and single-chip mode. In modes 1 to 4 (expanded modes with on-chip ROM disabled), they are address bus output pins (A_7 to A_0).

In modes 5 and 6 (expanded modes with on-chip ROM enabled), settings in the port 1 data direction register (P1DDR) can designate pins for address bus output (A_7 to A_0) or generic input. In mode 7 (single-chip mode), port 1 is a generic input/output port.

When DRAM is connected to area 3, A_7 to A_0 output row and column addresses in read and write cycles. For details see section 7, Refresh Controller.

Pins in port 1 can drive one TTL load and a 90-pF capacitive load. They can also drive a darlington transistor pair.

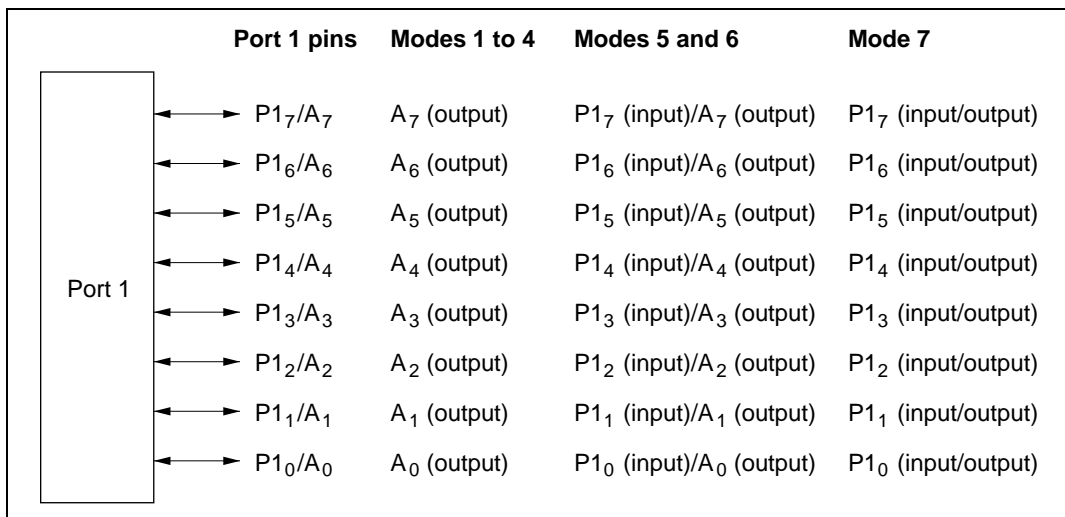

Figure 9.1 Port 1 Pin Configuration

9.2.2 Register Descriptions

Table 9.2 summarizes the registers of port 1.

Table 9.2 Port 1 Registers

Address*	Name	Abbreviation	R/W	Initial Value	
				Modes 1 to 4	Modes 5 to 7
H'FFC0	Port 1 data direction register	P1DDR	W	H'FF	H'00
H'FFC2	Port 1 data register	P1DR	R/W	H'00	H'00

Note: * Lower 16 bits of the address.

Port 1 Data Direction Register (P1DDR)

P1DDR is an 8-bit write-only register that can select input or output for each pin in port 1.

Bit								
	7	6	5	4	3	2	1	0
	P1 ₇ DDR	P1 ₆ DDR	P1 ₅ DDR	P1 ₄ DDR	P1 ₃ DDR	P1 ₂ DDR	P1 ₁ DDR	P1 ₀ DDR
Modes 1 to 4	Initial value	1	1	1	1	1	1	1
	Read/Write	—	—	—	—	—	—	—
Modes 5 to 7	Initial value	0	0	0	0	0	0	0
	Read/Write	W	W	W	W	W	W	W

Port 1 data direction 7 to 0

These bits select input or output for port 1 pins

Modes 1 to 4 (Expanded Modes with On-Chip ROM Disabled): P1DDR values are fixed at 1 and cannot be modified. Port 1 functions as an address bus.

Modes 5 and 6 (Expanded Modes with On-Chip ROM Enabled): A pin in port 1 becomes an address output pin if the corresponding P1DDR bit is set to 1, and a generic input pin if this bit is cleared to 0.

Mode 7 (Single-Chip Mode): Port 1 functions as an input/output port. A pin in port 1 becomes an output pin if the corresponding P1DDR bit is set to 1, and an input pin if this bit is cleared to 0.

In modes 5 to 7, P1DDR is a write-only register. Its value cannot be read. All bits return 1 when read.

P1DDR is initialized to H'FF in modes 1 to 4 and H'00 in modes 5 to 7 by a reset and in hardware standby mode. In software standby mode it retains its previous setting. If a P1DDR bit is set to 1, the corresponding pin maintains its output state in software standby mode.

Port 1 Data Register (P1DR)

P1DR is an 8-bit readable/writable register that stores output data for pins P1₇ to P1₀. While port 1 acts as an output port, the value of this register is output. When a bit in P1DDR is set to 1, if port 1 is read the value of the corresponding P1DR bit is returned. When a bit in P1DDR is cleared to 0, if port 1 is read the corresponding pin level is read.

Bit	7	6	5	4	3	2	1	0
	P1 ₇	P1 ₆	P1 ₅	P1 ₄	P1 ₃	P1 ₂	P1 ₁	P1 ₀
Initial value	0	0	0	0	0	0	0	0
Read/Write	R/W	R/W	R/W	R/W	R/W	R/W	R/W	R/W

Port 1 data 7 to 0

These bits store data for port 1 pins

P1DR is initialized to H'00 by a reset and in hardware standby mode. In software standby mode it retains its previous setting.

9.3 Port 2

9.3.1 Overview

Port 2 is an 8-bit input/output port with the pin configuration shown in figure 9.2. The pin functions differ according to the operating mode.

In modes 1 to 4 (expanded modes with on-chip ROM disabled), port 2 consists of address bus output pins (A_{15} to A_8). In modes 5 and 6 (expanded modes with on-chip ROM enabled), settings in the port 2 data direction register (P2DDR) can designate pins for address bus output (A_{15} to A_8) or generic input. In mode 7 (single-chip mode), port 2 is a generic input/output port.

When DRAM is connected to area 3, A_9 and A_8 output row and column addresses in read and write cycles. For details see section 7, Refresh Controller.

Port 2 has software-programmable built-in pull-up MOS. Pins in port 2 can drive one TTL load and a 90-pF capacitive load. They can also drive a darlington transistor pair.

Port 2 pins	Modes 1 to 4	Modes 5 and 6	Mode 7
$P2_7/A_{15}$	A_{15} (output)	$P2_7$ (input)/ A_{15} (output)	$P2_7$ (input/output)
$P2_6/A_{14}$	A_{14} (output)	$P2_6$ (input)/ A_{14} (output)	$P2_6$ (input/output)
$P2_5/A_{13}$	A_{13} (output)	$P2_5$ (input)/ A_{13} (output)	$P2_5$ (input/output)
$P2_4/A_{12}$	A_{12} (output)	$P2_4$ (input)/ A_{12} (output)	$P2_4$ (input/output)
$P2_3/A_{11}$	A_{11} (output)	$P2_3$ (input)/ A_{11} (output)	$P2_3$ (input/output)
$P2_2/A_{10}$	A_{10} (output)	$P2_2$ (input)/ A_{10} (output)	$P2_2$ (input/output)
$P2_1/A_9$	A_9 (output)	$P2_1$ (input)/ A_9 (output)	$P2_1$ (input/output)
$P2_0/A_8$	A_8 (output)	$P2_0$ (input)/ A_8 (output)	$P2_0$ (input/output)

Figure 9.2 Port 2 Pin Configuration

9.3.2 Register Descriptions

Table 9.3 summarizes the registers of port 2.

Table 9.3 Port 2 Registers

Address*	Name	Abbreviation	R/W	Initial Value	
				Modes 1 to 4	Modes 5 to 7
H'FFC1	Port 2 data direction register	P2DDR	W	H'FF	H'00
H'FFC3	Port 2 data register	P2DR	R/W	H'00	H'00
H'FFD8	Port 2 input pull-up MOS control register	P2PCR	R/W	H'00	H'00

Note: * Lower 16 bits of the address.

Port 2 Data Direction Register (P2DDR)

P2DDR is an 8-bit write-only register that can select input or output for each pin in port 2.

Bit	7	6	5	4	3	2	1	0
	P2 ₇ DDR	P2 ₆ DDR	P2 ₅ DDR	P2 ₄ DDR	P2 ₃ DDR	P2 ₂ DDR	P2 ₁ DDR	P2 ₀ DDR
Modes 1 to 4	Initial value	1	1	1	1	1	1	1
	Read/Write	—	—	—	—	—	—	—
Modes 5 to 7	Initial value	0	0	0	0	0	0	0
	Read/Write	W	W	W	W	W	W	W

Port 2 data direction 7 to 0

These bits select input or output for port 2 pins

Modes 1 to 4 (Expanded Modes with On-Chip ROM Disabled): P2DDR values are fixed at 1 and cannot be modified. Port 2 functions as an address bus.

Modes 5 and 6 (Expanded Modes with On-Chip ROM Enabled): Following a reset, port 2 is an input port. A pin in port 2 becomes an address output pin if the corresponding P2DDR bit is set to 1, and a generic input port if this bit is cleared to 0.

Mode 7 (Single-Chip Mode): Port 2 functions as an input/output port. A pin in port 2 becomes an output port if the corresponding P2DDR bit is set to 1, and an input port if this bit is cleared to 0.

In modes 1 to 4, P2DDR always returns 1 when read. No value can be written to.

In modes 5 to 7, P2DDR is a write-only register. Its value cannot be read. All bits return 1 when read.

P2DDR is initialized to H'FF in modes 1 to 4 and H'00 in modes 5 to 7 by a reset and in hardware standby mode. In software standby mode it retains its previous setting. If a P2DDR bit is set to 1, the corresponding pin maintains its output state in software standby mode.

Port 2 Data Register (P2DR)

P2DR is an 8-bit readable/writable register that stores output data for pins P2₇ to P2₀. While port 2 acts as an output port, the value of this register is output. When a bit in P2DDR is set to 1, if port 2 is read the value of the corresponding P2DR bit is returned. When a bit in P2DDR is cleared to 0, if port 2 is read the corresponding pin level is read.

Bit	7	6	5	4	3	2	1	0
	P2 ₇	P2 ₆	P2 ₅	P2 ₄	P2 ₃	P2 ₂	P2 ₁	P2 ₀
Initial value	0	0	0	0	0	0	0	0
Read/Write	R/W	R/W	R/W	R/W	R/W	R/W	R/W	R/W

Port 2 data 7 to 0

These bits store data for port 2 pins

P2DR is initialized to H'00 by a reset and in hardware standby mode. In software standby mode it retains its previous setting.

Port 2 Input Pull-Up MOS Control Register (P2PCR)

P2PCR is an 8-bit readable/writable register that controls the MOS input pull-up transistors in port 2.

Bit	7	6	5	4	3	2	1	0
	P2 ₇ PCR	P2 ₆ PCR	P2 ₅ PCR	P2 ₄ PCR	P2 ₃ PCR	P2 ₂ PCR	P2 ₁ PCR	P2 ₀ PCR
Initial value	0	0	0	0	0	0	0	0
Read/Write	R/W	R/W	R/W	R/W	R/W	R/W	R/W	R/W

Port 2 input pull-up MOS control 7 to 0

These bits control input pull-up transistors built into port 2

In modes 5 to 7, when a P2DDR bit is cleared to 0 (selecting generic input), if the corresponding bit from P2₇PCR to P2₀PCR is set to 1, the input pull-up MOS is turned on.

P2PCR is initialized to H'00 by a reset and in hardware standby mode. In software standby mode it retains its previous setting.

Table 9.4 summarizes the states of the input pull-up transistors.

Table 9.4 Input Pull-Up MOS States (Port 2)

Mode	Reset	Hardware Standby Mode	Software Standby Mode	Other Modes
1	Off	Off	Off	Off
2				
3				
4				
5	Off	Off	On/off	On/off
6				
7				

Legend:

Off: The input pull-up MOS is always off.

On/off: The input pull-up MOS is on if P2PCR = 1 and P2DDR = 0. Otherwise, it is off.

9.4 Port 3

9.4.1 Overview

Port 3 is an 8-bit input/output port with the pin configuration shown in figure 9.3. Port 3 is a data bus in modes 1 to 6 (expanded modes) and a generic input/output port in mode 7 (single-chip mode).

Pins in port 3 can drive one TTL load and a 90-pF capacitive load. They can also drive a darlington transistor pair.

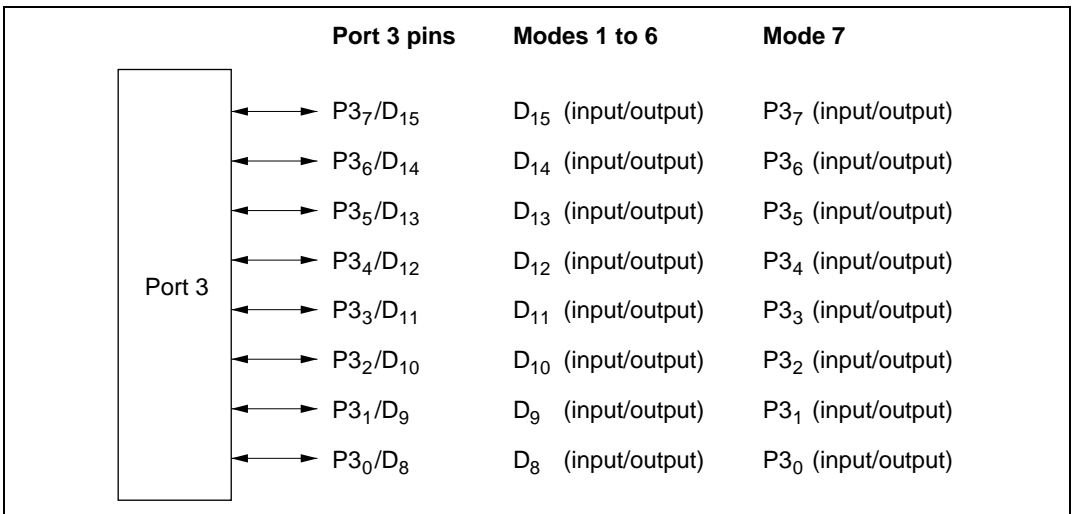

Figure 9.3 Port 3 Pin Configuration

9.4.2 Register Descriptions

Table 9.5 summarizes the registers of port 3.

Table 9.5 Port 3 Registers

Address*	Name	Abbreviation	R/W	Initial Value
H'FFC4	Port 3 data direction register	P3DDR	W	H'00
H'FFC6	Port 3 data register	P3DR	R/W	H'00

Note: * Lower 16 bits of the address.

Port 3 Data Direction Register (P3DDR)

P3DDR is an 8-bit write-only register that can select input or output for each pin in port 3.

Bit	7	6	5	4	3	2	1	0
	P3 ₇ DDR	P3 ₆ DDR	P3 ₅ DDR	P3 ₄ DDR	P3 ₃ DDR	P3 ₂ DDR	P3 ₁ DDR	P3 ₀ DDR
Initial value	0	0	0	0	0	0	0	0
Read/Write	W	W	W	W	W	W	W	W

Port 3 data direction 7 to 0

These bits select input or output for port 3 pins

Modes 1 to 6 (Expanded Modes): Port 3 functions as a data bus. P3DDR is ignored.

Mode 7 (Single-Chip Mode): Port 3 functions as an input/output port. A pin in port 3 becomes an output port if the corresponding P3DDR bit is set to 1, and an input port if this bit is cleared to 0.

P3DDR is a write-only register. Its value cannot be read. All bits return 1 when read.

P3DDR is initialized to H'00 by a reset and in hardware standby mode. In software standby mode it retains its previous setting. If a P3DDR bit is set to 1, the corresponding pin maintains its output state in software standby mode.

Port 3 Data Register (P3DR)

P3DR is an 8-bit readable/writable register that stores output data for pins P3₇ to P3₀. While port 3 acts as an output port, the value of this register is output. When a bit in P3DDR is set to 1, if port 3 is read the value of the corresponding P3DR bit is returned. When a bit in P3DDR is cleared to 0, if port 3 is read the corresponding pin level is read.

Bit	7	6	5	4	3	2	1	0
	P3 ₇	P3 ₆	P3 ₅	P3 ₄	P3 ₃	P3 ₂	P3 ₁	P3 ₀
Initial value	0	0	0	0	0	0	0	0
Read/Write	R/W	R/W	R/W	R/W	R/W	R/W	R/W	R/W

Port 3 data 7 to 0

These bits store data for port 3 pins

P3DR is initialized to H'00 by a reset and in hardware standby mode. In software standby mode it retains its previous setting.

9.5 Port 4

9.5.1 Overview

Port 4 is an 8-bit input/output port with the pin configuration shown in figure 9.4. The pin functions differ according to the operating mode.

In modes 1 to 6 (expanded modes), when the bus width control register (ABWCR) designates areas 0 to 7 all as 8-bit-access areas, the chip operates in 8-bit bus mode and port 4 is a generic input/output port. When at least one of areas 0 to 7 is designated as a 16-bit-access area, the chip operates in 16-bit bus mode and port 4 becomes part of the data bus. In mode 7 (single-chip mode), port 4 is a generic input/output port.

Port 4 has software-programmable built-in pull-up MOS.

Pins in port 4 can drive one TTL load and a 90-pF capacitive load. They can also drive a darlington transistor pair.

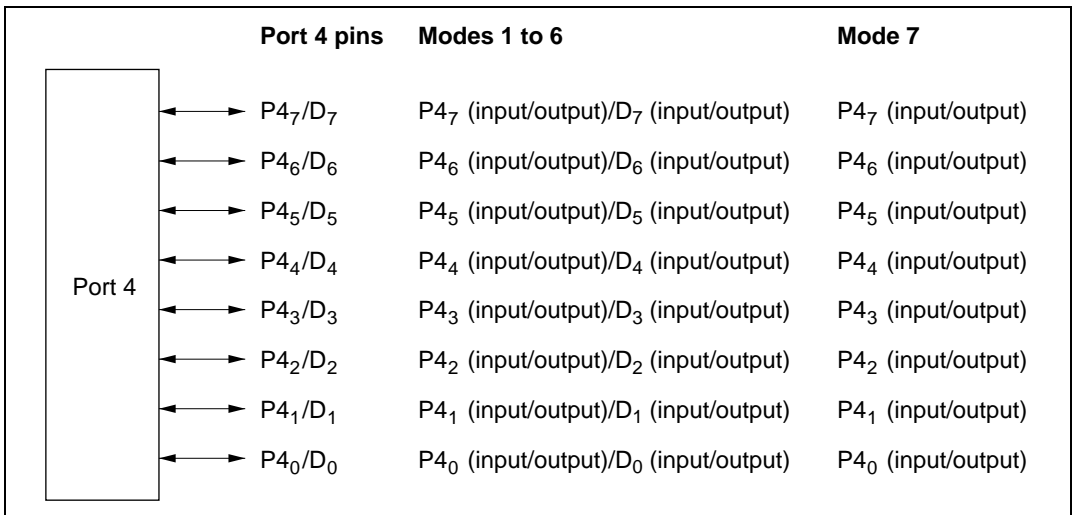

Figure 9.4 Port 4 Pin Configuration

9.5.2 Register Descriptions

Table 9.6 summarizes the registers of port 4.

Table 9.6 Port 4 Registers

Address*	Name	Abbreviation	R/W	Initial Value
H'FFC5	Port 4 data direction register	P4DDR	W	H'00
H'FFC7	Port 4 data register	P4DR	R/W	H'00
H'FFDA	Port 4 input pull-up MOS control register	P4PCR	R/W	H'00

Note: * Lower 16 bits of the address.

Port 4 Data Direction Register (P4DDR)

P4DDR is an 8-bit write-only register that can select input or output for each pin in port 4.

Bit	7	6	5	4	3	2	1	0
	P4 ₇ DDR	P4 ₆ DDR	P4 ₅ DDR	P4 ₄ DDR	P4 ₃ DDR	P4 ₂ DDR	P4 ₁ DDR	P4 ₀ DDR
Initial value	0	0	0	0	0	0	0	0
Read/Write	W	W	W	W	W	W	W	W

Port 4 data direction 7 to 0

These bits select input or output for port 4 pins

Modes 1 to 6 (Expanded Modes): When all areas are designated as 8-bit-access areas using the bus width control register (ABWCR) of the bus controller, selecting 8-bit bus mode, port 4 functions as a generic input/output port. A pin in port 4 becomes an output port if the corresponding P4DDR bit is set to 1, and an input port if this bit is cleared to 0.

When at least one area is designated as a 16-bit-access area, selecting 16-bit bus mode, port 4 functions as part of the data bus regardless of the value in P4DDR.

Mode 7 (Single-Chip Mode): Port 4 functions as an input/output port. A pin in port 4 becomes an output port if the corresponding P4DDR bit is set to 1, and an input port if this bit is cleared to 0.

P4DDR is a write-only register. Its value cannot be read. All bits return 1 when read.

P4DDR is initialized to H'00 by a reset and in hardware standby mode. In software standby mode it retains its previous setting.

ABWCR and P4DDR are not initialized in software standby mode. When port 4 functions as a generic input/output port, if a P4DDR bit is set to 1, the corresponding pin maintains its output state in software standby mode.

Port 4 Data Register (P4DR)

P4DR is an 8-bit readable/writable register that stores output data for pins P4₇ to P4₀. While port 4 acts as an output port, the value of this register is output. When a bit in P4DDR is set to 1, if port 4 is read the value of the corresponding P4DR bit is returned. When a bit in P4DDR is cleared to 0, if port 4 is read the corresponding pin level is read.

Bit	7	6	5	4	3	2	1	0
	P4 ₇	P4 ₆	P4 ₅	P4 ₄	P4 ₃	P4 ₂	P4 ₁	P4 ₀
Initial value	0	0	0	0	0	0	0	0
Read/Write	R/W	R/W	R/W	R/W	R/W	R/W	R/W	R/W

Port 4 data 7 to 0

These bits store data for port 4 pins

P4DR is initialized to H'00 by a reset and in hardware standby mode. In software standby mode it retains its previous setting.

Port 4 Input Pull-Up MOS Control Register (P4PCR)

P4PCR is an 8-bit readable/writable register that controls the MOS input pull-up transistors in port 4.

Bit	7	6	5	4	3	2	1	0
	P4 ₇ PCR	P4 ₆ PCR	P4 ₅ PCR	P4 ₄ PCR	P4 ₃ PCR	P4 ₂ PCR	P4 ₁ PCR	P4 ₀ PCR
Initial value	0	0	0	0	0	0	0	0
Read/Write	R/W	R/W	R/W	R/W	R/W	R/W	R/W	R/W

Port 4 input pull-up MOS control 7 to 0

These bits control input pull-up MOS transistors built into port 4

In mode 7 (single-chip mode), and in 8-bit bus mode in modes 1 to 6 (expanded modes), when a P4DDR bit is cleared to 0 (selecting generic input), if the corresponding P4PCR bit is set to 1, the input pull-up MOS transistor is turned on.

P4PCR is initialized to H'00 by a reset and in hardware standby mode. In software standby mode it retains its previous setting.

Table 9.7 summarizes the states of the input pull-ups MOS in the 8-bit and 16-bit bus modes.

Table 9.7 Input Pull-Up MOS Transistor States (Port 4)

Mode		Reset	Hardware Standby Mode	Software Standby Mode	Other Modes
1 to 6	8-bit bus mode	Off	Off	On/off	On/off
	16-bit bus mode			Off	Off
7				On/off	On/off

Legend:

Off: The input pull-up MOS transistor is always off.

On/off: The input pull-up MOS transistor is on if P4PCR = 1 and P4DDR = 0. Otherwise, it is off.

9.6 Port 5

9.6.1 Overview

Port 5 is a 4-bit input/output port with the pin configuration shown in figure 9.5. The pin functions differ depending on the operating mode.

In modes 1 to 4 (expanded modes with on-chip ROM disabled), port 5 consists of address output pins (A_{19} to A_{16}). In modes 5 and 6 (expanded modes with on-chip ROM enabled), settings in the port 5 data direction register (P5DDR) designate pins for address bus output (A_{19} to A_{16}) or generic input. In mode 7 (single-chip mode), port 5 is a generic input/output port.

Port 5 has software-programmable built-in pull-up MOS transistors.

Pins in port 5 can drive one TTL load and a 90-pF capacitive load. They can also drive an LED or a darlington transistor pair.

	Port 5 pins	Modes 1 to 4	Modes 5 and 6	Mode 7
	P5 ₃ /A ₁₉	A ₁₉ (output)	P5 ₃ (input)/A ₁₉ (output)	P5 ₃ (input/output)
	P5 ₂ /A ₁₈	A ₁₈ (output)	P5 ₂ (input)/A ₁₈ (output)	P5 ₂ (input/output)
	P5 ₁ /A ₁₇	A ₁₇ (output)	P5 ₁ (input)/A ₁₇ (output)	P5 ₁ (input/output)
	P5 ₀ /A ₁₆	A ₁₆ (output)	P5 ₀ (input)/A ₁₆ (output)	P5 ₀ (input/output)

Figure 9.5 Port 5 Pin Configuration

9.6.2 Register Descriptions

Table 9.8 summarizes the registers of port 5.

Table 9.8 Port 5 Registers

Address*	Name	Abbreviation	R/W	Initial Value	
				Modes 1 to 4	Modes 5 to 7
H'FFC8	Port 5 data direction register	P5DDR	W	H'FF	H'F0
H'FFCA	Port 5 data register	P5DR	R/W	H'F0	H'F0
H'FFDB	Port 5 input pull-up MOS control register	P5PCR	R/W	H'F0	H'F0

Note: * Lower 16 bits of the address.

Port 5 Data Direction Register (P5DDR)

P5DDR is an 8-bit write-only register that can select input or output for each pin in port 5.

Bits 7 to 4 are reserved. They cannot be modified and are always read as 1.

Bit	7	6	5	4	3	2	1	0
	—	—	—	—	P5 ₃ DDR	P5 ₂ DDR	P5 ₁ DDR	P5 ₀ DDR
Modes 1 to 4	Initial value	1	1	1	1	1	1	1
	Read/Write	—	—	—	—	—	—	—
Modes 5 to 7	Initial value	1	1	1	0	0	0	0
	Read/Write	—	—	—	W	W	W	W

Reserved bits

Port 5 data direction 3 to 0

These bits select input or output for port 5 pins

Modes 1 to 4 (Expanded Modes with On-Chip ROM Disabled): P5DDR values are fixed at 1 and cannot be modified. Port 5 functions as an address bus.

Modes 5 and 6 (Expanded Modes with On-Chip ROM Enabled): Following a reset, port 5 is an input port. A pin in port 5 becomes an address output pin if the corresponding P5DDR bit is set to 1, and an input port if this bit is cleared to 0.

Mode 7 (Single-Chip Mode): Port 5 functions as an input/output port. A pin in port 5 becomes an output port if the corresponding P5DDR bit is set to 1, and an input port if this bit is cleared to 0.

In modes 1 to 4, P5DDR always returns 1 when read. No value can be written to.

In modes 5 to 7, P5DDR is a write-only register. Its value cannot be read. All bits return 1 when read.

P5DDR is initialized to H'FF in modes 1 to 4 and H'F0 in modes 5 to 7 by a reset and in hardware standby mode. In software standby mode it retains its previous setting, so if a P5DDR bit is set to 1 while port 5 acts as an I/O port, the corresponding pin maintains its output state in software standby mode.

Port 5 Data Register (P5DR)

P5DR is an 8-bit readable/writable register that stores output data for pins P5₃ to P5₀. While port 5 acts as an output port, the value of this register is output. When a bit in P5DDR is set to 1, if port 5 is read the value of the corresponding P5DR bit is returned. When a bit in P5DDR is cleared to 0, if port 5 is read the corresponding pin level is read.

Bits 7 to 4 are reserved. They cannot be modified and are always read as 1.

Bit	7	6	5	4	3	2	1	0
	—	—	—	—	P5 ₃	P5 ₂	P5 ₁	P5 ₀
Initial value	1	1	1	1	0	0	0	0
Read/Write	—	—	—	—	R/W	R/W	R/W	R/W

Reserved bits
Port 5 data 3 to 0
These bits store data for port 5 pins

P5DR is initialized to H'F0 by a reset and in hardware standby mode. In software standby mode it retains its previous setting.

Port 5 Input Pull-Up MOS Control Register (P5PCR)

P5PCR is an 8-bit readable/writable register that controls the MOS input pull-up MOS transistors in port 5.

Bits 7 to 4 are reserved. They cannot be modified and are always read as 1.

Bit	7	6	5	4	3	2	1	0
	—	—	—	—	P5 ₃ PCR	P5 ₂ PCR	P5 ₁ PCR	P5 ₀ PCR
Initial value	1	1	1	1	0	0	0	0
Read/Write	—	—	—	—	R/W	R/W	R/W	R/W

Reserved bits
Port 5 input pull-up MOS control 3 to 0
 These bits control input pull-up MOS transistors built into port 5

In modes 5 to 7, when a P5DDR bit is cleared to 0 (selecting generic input), if the corresponding bit from P5₃PCR to P5₀PCR is set to 1, the input pull-up MOS transistor is turned on.

P5PCR is initialized to H'F0 by a reset and in hardware standby mode. In software standby mode it retains its previous setting.

Table 9.9 summarizes the states of the input pull-ups MOS in each mode.

Table 9.9 Input Pull-Up MOS Transistor States (Port 5)

Mode	Reset	Hardware Standby Mode	Software Standby Mode	Other Modes
1	Off	Off	Off	Off
2				
3				
4				
5	Off	Off	On/off	On/off
6				
7				

Legend:

Off: The input pull-up MOS transistor is always off.

On/off: The input pull-up MOS transistor is on if P5PCR = 1 and P5DDR = 0. Otherwise, it is off.

9.7 Port 6

9.7.1 Overview

Port 6 is a 7-bit input/output port that is also used for input and output of bus control signals ($\overline{\text{LWR}}$, $\overline{\text{HWR}}$, $\overline{\text{RD}}$, $\overline{\text{AS}}$, $\overline{\text{BACK}}$, $\overline{\text{BREQ}}$, and $\overline{\text{WAIT}}$). When DRAM is connected to area 3, $\overline{\text{LWR}}$, $\overline{\text{HWR}}$, and $\overline{\text{RD}}$ also function as $\overline{\text{LW}}$, $\overline{\text{UW}}$, and $\overline{\text{CAS}}$, or $\overline{\text{LCAS}}$, $\overline{\text{UCAS}}$, and $\overline{\text{WE}}$, respectively. For details see section 7, Refresh Controller.

Figure 9.6 shows the pin configuration of port 6. In modes 1 to 6 (expanded modes) the pin functions are $\overline{\text{LWR}}$, $\overline{\text{HWR}}$, $\overline{\text{RD}}$, $\overline{\text{AS}}$, $\text{P6}_2/\overline{\text{BACK}}$, $\text{P6}_1/\overline{\text{BREQ}}$, and $\text{P6}_0/\overline{\text{WAIT}}$. See table 9.11 for the method of selecting the pin states. In mode 7 (single-chip mode) port 6 is a generic input/output port.

Pins in port 6 can drive one TTL load and a 30-pF capacitive load. They can also drive a darlington transistor pair.

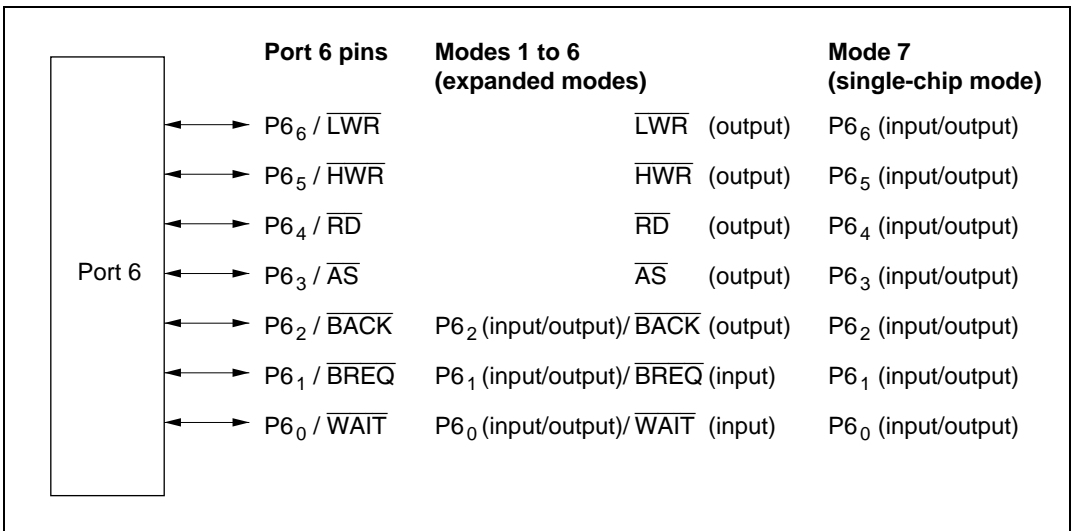

Figure 9.6 Port 6 Pin Configuration

9.7.2 Register Descriptions

Table 9.10 summarizes the registers of port 6.

Table 9.10 Port 6 Registers

Address*	Name	Abbreviation	R/W	Initial Value	
				Modes 1 to 5	Modes 6, 7
H'FFC9	Port 6 data direction register	P6DDR	W	H'F8	H'80
H'FFCB	Port 6 data register	P6DR	R/W	H'80	H'80

Note: * Lower 16 bits of the address.

Port 6 Data Direction Register (P6DDR)

P6DDR is an 8-bit write-only register that can select input or output for each pin in port 6. Bit 7 is reserved. It cannot be modified and is always read as 1.

Bit	7	6	5	4	3	2	1	0
	—	P6 ₆ DDR	P6 ₅ DDR	P6 ₄ DDR	P6 ₃ DDR	P6 ₂ DDR	P6 ₁ DDR	P6 ₀ DDR
Initial value	1	0	0	0	0	0	0	0
Read/Write	—	W	W	W	W	W	W	W

Reserved bit
Port 6 data direction 6 to 0
 These bits select input or output for port 6 pins

Modes 1 to 6 (Expanded Modes): Ports P6₆ to P6₃ function as bus control output pins ($\overline{\text{LWR}}$, $\overline{\text{HWR}}$, $\overline{\text{RD}}$, $\overline{\text{AS}}$), regardless of the settings of P6₆DDR to P6₃DDR. Ports P6₂ to P6₀ function as the bus control pins ($\overline{\text{BACK}}$, $\overline{\text{BREQ}}$, $\overline{\text{WAIT}}$) or I/O ports. For selecting the pin function, see table 9.11. When ports P6₂ to P6₀ function as I/O ports and if P6DDR is set to 1, the corresponding pin of port 6 functions as an output port. If P6DDR is cleared to 0, the corresponding pin functions as an input port.

Mode 7 (Single-Chip Mode): Port 6 is a generic input/output port. A pin in port 6 becomes an output port if the corresponding P6DDR bit is set to 1, and an input port if this bit is cleared to 0.

P6DDR is a write-only register. Its value cannot be read. All bits return 1 when read.

P6DDR is initialized to H'80 by a reset and in hardware standby mode. In software standby mode it retains its previous setting. If a P6DDR bit is set to 1 while port 6 acts as an I/O port, the corresponding pin maintains its output state in software standby mode.

Port 6 Data Register (P6DR)

P6DR is an 8-bit readable/writable register that stores output data for pins P6₆ to P6₀. When this register is read, bits 6 to 0 each returns the logic level of the pin, when the corresponding bit of P6DDR is 0. When the corresponding bit of P6DDR is 1, bits 6 to 0 return the P6DR value.

Bit	7	6	5	4	3	2	1	0
	—	P6 ₆	P6 ₅	P6 ₄	P6 ₃	P6 ₂	P6 ₁	P6 ₀
Initial value	1	0	0	0	0	0	0	0
Read/Write	—	R/W	R/W	R/W	R/W	R/W	R/W	R/W

Reserved bit
Port 6 data 6 to 0
 These bits store data for port 6 pins

Bit 7 is reserved, cannot be modified, and always read as 1.

P6DR is initialized to H'80 by a reset and in hardware standby mode. In software standby mode it retains its previous setting.

Table 9.11 Port 6 Pin Functions in Modes 1 to 6

Pin	Pin Functions and Selection Method		
P6 ₆ /LWR	Functions as follows regardless of P6 ₆ DDR		
	P6 ₆ DDR	0	1
	Pin function	LWR output	
P6 ₅ /HWR	Functions as follows regardless of P6 ₅ DDR		
	P6 ₅ DDR	0	1
	Pin function	HWR output	
P6 ₄ /RD	Functions as follows regardless of P6 ₄ DDR		
	P6 ₄ DDR	0	1
	Pin function	RD output	

Pin Pin Functions and Selection Method

P6₃/ $\overline{\text{AS}}$ Functions as follows regardless of P6₃DDR

P6 ₃ DDR	0	1
Pin function	$\overline{\text{AS}}$ output	

P6₂/ $\overline{\text{BACK}}$ Bit BRLE in BRCR and bit P6₂DDR select the pin function as follows

BRLE	0	1	
P6 ₂ DDR	0	1	—
Pin function	P6 ₂ input	P6 ₂ output	$\overline{\text{BACK}}$ output

P6₁/ $\overline{\text{BREQ}}$ Bit BRLE in BRCR and bit P6₁DDR select the pin function as follows

BRLE	0	1	
P6 ₁ DDR	0	1	—
Pin function	P6 ₁ input	P6 ₁ output	$\overline{\text{BREQ}}$ input

P6₀/ $\overline{\text{WAIT}}$ Bits WCE7 to WCE0 in WCER, bit WMS1 in WCR, and bit P6₀DDR select the pin function as follows

WCER	All 1s		Not all 1s	
WMS1	0	1	—	
P6 ₀ DDR	0	1	0*	0*
Pin function	P6 ₀ input	P6 ₀ output	$\overline{\text{WAIT}}$ input	

Note: * Do not set bit P6₀DDR to 1.

9.8 Port 7

9.8.1 Overview

Port 7 is an 8-bit input port that is also used for analog input to the A/D converter and analog output from the D/A converter. The pin functions are the same in all operating modes. Figure 9.7 shows the pin configuration of port 7.

For the analog input pins of the A/D converter, see section 15, A/D Converter.

For the analog input pins of the D/A converter, see section 16, D/A Converter.

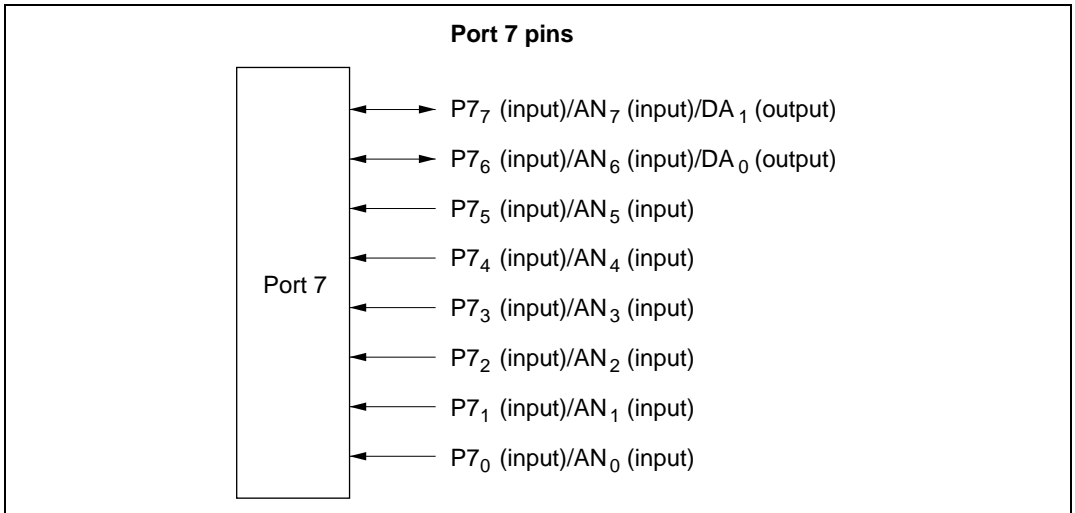

Figure 9.7 Port 7 Pin Configuration

9.8.2 Register Description

Table 9.12 summarizes the port 7 register. Port 7 is an input-only port, so it has no data direction register.

Table 9.12 Port 7 Data Register

Address*	Name	Abbreviation	R/W	Initial Value
H'FFCE	Port 7 data register	P7DR	R	Undetermined

Note: * Lower 16 bits of the address.

Port 7 Data Register (P7DR)

Bit	7	6	5	4	3	2	1	0
	P7 ₇	P7 ₆	P7 ₅	P7 ₄	P7 ₃	P7 ₂	P7 ₁	P7 ₀
Initial value	—*	—*	—*	—*	—*	—*	—*	—*
Read/Write	R	R	R	R	R	R	R	R

Note: * Determined by pins P7₇ to P7₀.

When P7DR is read, the logic level of the pin is always read. No data can be written to.

9.9 Port 8

9.9.1 Overview

Port 8 is a 5-bit input/output port that is also used for \overline{CS}_3 to \overline{CS}_0 output, \overline{RFSH} output, and \overline{IRQ}_3 to \overline{IRQ}_0 input. Figure 9.8 shows the pin configuration of port 8.

In modes 1 to 6 (expanded modes), port 8 can provide \overline{CS}_3 to \overline{CS}_0 output, \overline{RFSH} output, and \overline{IRQ}_3 to \overline{IRQ}_0 input. See table 9.14 for the selection of pin functions in expanded modes.

In mode 7 (single-chip mode), port 8 can provide \overline{IRQ}_3 to \overline{IRQ}_0 input. See table 9.15 for the selection of pin functions in single-chip mode.

The \overline{IRQ}_3 to \overline{IRQ}_0 functions are selected by IER settings, regardless of whether the pin is used for input or output. For details see section 5, Interrupt Controller.

Pins in port 8 can drive one TTL load and a 90-pF capacitive load. They can also drive a darlington transistor pair.

Pins P8₂ to P8₀ have Schmitt-trigger inputs.

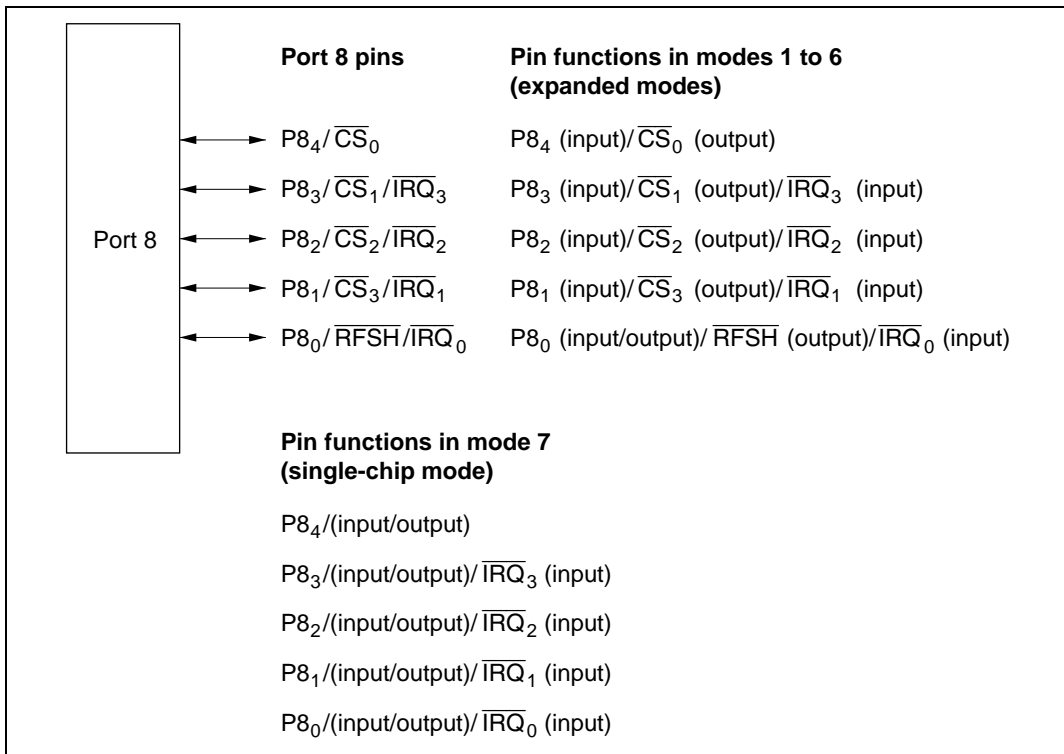

Figure 9.8 Port 8 Pin Configuration

9.9.2 Register Descriptions

Table 9.13 summarizes the registers of port 8.

Table 9.13 Port 8 Registers

Address*	Name	Abbreviation	R/W	Initial Value	
				Modes 1 to 4	Modes 5 to 7
H'FFCD	Port 8 data direction register	P8DDR	W	H'F0	H'E0
H'FFCF	Port 8 data register	P8DR	R/W	H'E0	H'E0

Note: * Lower 16 bits of the address.

Port 8 Data Direction Register (P8DDR)

P8DDR is an 8-bit write-only register that can select input or output for each pin in port 8.

Bits 7 to 5 are reserved. They cannot be modified and are always read as 1.

Bit	7	6	5	4	3	2	1	0
	—	—	—	P8 ₄ DDR	P8 ₃ DDR	P8 ₂ DDR	P8 ₁ DDR	P8 ₀ DDR
Modes 1 to 4	Initial value	1	1	1	0	0	0	0
	Read/Write	—	—	—	W	W	W	W
Modes 5 to 7	Initial value	1	1	1	0	0	0	0
	Read/Write	—	—	—	W	W	W	W

Reserved bits
Port 8 data direction 4 to 0
These bits select input or output for port 8 pins

Modes 1 to 6 (Expanded Modes): When bits in P8DDR bit are set to 1, P8₄ to P8₁ become \overline{CS}_0 to \overline{CS}_3 output pins. When bits in P8DDR are cleared to 0, the corresponding pins become input ports. In modes 1 to 4 (expanded modes with on-chip ROM disabled), following a reset only \overline{CS}_0 is output. The other three pins are input ports. In modes 5 and 6 (expanded modes with on-chip ROM enabled), following a reset all four pins are input ports.

When the refresh controller is enabled, P8₀ is used unconditionally for \overline{RFSH} output. When the refresh controller is disabled, P8₀ becomes a generic input/output port according to the P8DDR setting. For details see table 9.15.

Mode 7 (Single-Chip Mode): Port 8 is a generic input/output port. A pin in port 8 becomes an output port if the corresponding P8DDR bit is set to 1, and an input port if this bit is cleared to 0.

P8DDR is a write-only register. Its value cannot be read. All bits return 1 when read.

P8DDR is initialized to H'F0 in modes 1 to 4 and H'E0 in modes 5 to 7 by a reset and in hardware standby mode. In software standby mode it retains its previous setting, so if a P8DDR bit is set to 1 while port 8 acts as an I/O port, the corresponding pin maintains its output state in software standby mode.

Port 8 Data Register (P8DR)

P8DR is an 8-bit readable/writable register that stores output data for pins P8₄ to P8₀. While port 8 acts as an output port, the value of this register is output. When a bit in P8DDR is set to 1, if port 8 is read the value of the corresponding P8DR bit is returned. When a bit in P8DDR is cleared to 0, if port 8 is read the corresponding pin level is read.

Bits 7 to 5 are reserved. They cannot be modified and always are read as 1.

Bit	7	6	5	4	3	2	1	0
	—	—	—	P8 ₄	P8 ₃	P8 ₂	P8 ₁	P8 ₀
Initial value	1	1	1	0	0	0	0	0
Read/Write	—	—	—	R/W	R/W	R/W	R/W	R/W

Reserved bits
Port 8 data 4 to 0
These bits store data for port 8 pins

P8DR is initialized to H'E0 by a reset and in hardware standby mode. In software standby mode it retains its previous setting.

Table 9.14 Port 8 Pin Functions in Modes 1 to 6

Pin	Pin Functions and Selection Method		
$P8_4/\overline{CS}_0$	Bit P8 ₄ DDR selects the pin function as follows		
	P8 ₄ DDR	0	1
	Pin function	P8 ₄ input	\overline{CS}_0 output
$P8_3/\overline{CS}_1/\overline{IRQ}_3$	Bit P8 ₃ DDR selects the pin function as follows		
	P8 ₃ DDR	0	1
	Pin function	P8 ₃ input	\overline{CS}_1 output
$P8_2/\overline{CS}_2/\overline{IRQ}_2$	Bit P8 ₂ DDR selects the pin function as follows		
	P8 ₂ DDR	0	1
	Pin function	P8 ₂ input	\overline{CS}_2 output
$P8_1/\overline{CS}_3/\overline{IRQ}_1$	Bit P8 ₁ DDR selects the pin function as follows		
	P8 ₁ DDR	0	1
	Pin function	P8 ₁ input	\overline{CS}_3 output
$P8_0/\overline{RFSH}/\overline{IRQ}_0$	Bit RFSHE in RFSHCR and bit P8 ₀ DDR select the pin function as follows		
	RFSHE	0	
	P8 ₀ DDR	0	1
	Pin function	P8 ₀ input	P8 ₀ output
		\overline{IRQ}_0 input	

Table 9.15 Port 8 Pin Functions in Mode 7

Pin	Pin Functions and Selection Method		
P8 ₄	Bit P8 ₄ DDR selects the pin function as follows		
	P8 ₄ DDR	0	1
	Pin function	P8 ₄ input	P8 ₄ output
P8 ₃ / $\overline{\text{IRQ}}_3$	Bit P8 ₃ DDR selects the pin function as follows		
	P8 ₃ DDR	0	1
	Pin function	P8 ₃ input	P8 ₃ output
$\overline{\text{IRQ}}_3$ input			
P8 ₂ / $\overline{\text{IRQ}}_2$	Bit P8 ₂ DDR selects the pin function as follows		
	P8 ₂ DDR	0	1
	Pin function	P8 ₂ input	P8 ₂ output
$\overline{\text{IRQ}}_2$ input			
P8 ₁ / $\overline{\text{IRQ}}_1$	Bit P8 ₁ DDR selects the pin function as follows		
	P8 ₁ DDR	0	1
	Pin function	P8 ₁ input	P8 ₁ output
$\overline{\text{IRQ}}_1$ input			
P8 ₀ / $\overline{\text{IRQ}}_0$	Bit P8 ₀ DDR select the pin function as follows		
	P8 ₀ DDR	0	1
	Pin function	P8 ₀ input	P8 ₀ output
$\overline{\text{IRQ}}_0$ input			

9.10 Port 9

9.10.1 Overview

Port 9 is a 6-bit input/output port that is also used for input and output (TxD₀, TxD₁, RxD₀, RxD₁, SCK₀, SCK₁) by serial communication interface channels 0 and 1 (SCI0 and SCI1), and for $\overline{\text{IRQ}}_5$ and $\overline{\text{IRQ}}_4$ input. See table 9.17 for the selection of pin functions.

The $\overline{\text{IRQ}}_5$ and $\overline{\text{IRQ}}_4$ functions are selected by IER settings, regardless of whether the pin is used for input or output. For details see section 5, Interrupt Controller.

Port 9 has the same set of pin functions in all operating modes. Figure 9.9 shows the pin configuration of port 9.

Pins in port 9 can drive one TTL load and a 30-pF capacitive load. They can also drive a darlington transistor pair.

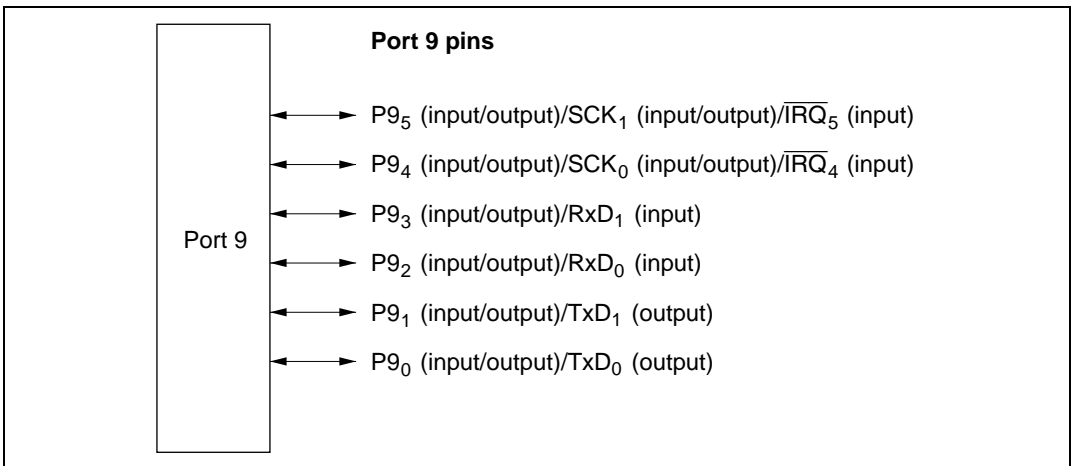

Figure 9.9 Port 9 Pin Configuration

9.10.2 Register Descriptions

Table 9.16 summarizes the registers of port 9.

Table 9.16 Port 9 Registers

Address*	Name	Abbreviation	R/W	Initial Value
H'FFD0	Port 9 data direction register	P9DDR	W	H'C0
H'FFD2	Port 9 data register	P9DR	R/W	H'C0

Note: * Lower 16 bits of the address.

Port 9 Data Direction Register (P9DDR)

P9DDR is an 8-bit write-only register that can select input or output for each pin in port 9.

Bits 7 and 6 are reserved. They cannot be modified and are always read as 1.

Bit	7	6	5	4	3	2	1	0
	—	—	P9 ₅ DDR	P9 ₄ DDR	P9 ₃ DDR	P9 ₂ DDR	P9 ₁ DDR	P9 ₀ DDR
Initial value	1	1	0	0	0	0	0	0
Read/Write	—	—	W	W	W	W	W	W

Reserved bits
Port 9 data direction 5 to 0
These bits select input or output for port 9 pins

While port 9 acts as an I/O port, a pin in port 9 becomes an output port if the corresponding P9DDR bit is set to 1, and an input port if this bit is cleared to 0. For selecting the pin function, see table 9.17.

P9DDR is a write-only register. Its value cannot be read. All bits return 1 when read.

P9DDR is initialized to H'C0 by a reset and in hardware standby mode. In software standby mode it retains its previous setting. If a P9DDR bit is set to 1 while port 9 acts as an I/O port, the corresponding pin maintains its output state in software standby mode.

Port 9 Data Register (P9DR)

P9DR is an 8-bit readable/writable register that stores output data for pins P9₅ to P9₀. While port 9 acts as an output port, the value of this register is output. When a bit in P9DDR is set to 1, if port 9 is read the value of the corresponding P9DR bit is returned. When a bit in P9DDR is cleared to 0, if port 9 is read the corresponding pin level is read.

Bit	7	6	5	4	3	2	1	0
	—	—	P9 ₅	P9 ₄	P9 ₃	P9 ₂	P9 ₁	P9 ₀
Initial value	1	1	0	0	0	0	0	0
Read/Write	—	—	R/W	R/W	R/W	R/W	R/W	R/W

Reserved bits
Port 9 data 5 to 0
These bits store data
for port 9 pins

Bits 7 and 6 are reserved. They cannot be modified and are always read as 1.

P9DR is initialized to H'C0 by a reset and in hardware standby mode. In software standby mode it retains its previous setting.

Table 9.17 Port 9 Pin Functions

Pin	Pin Functions and Selection Method				
$P9_5/SCK_1/\overline{IRQ}_5$	Bit C/\overline{A} in SMR of SCI1, bits CKE0 and CKE1 in SCR of SCI1, and bit $P9_5DDR$ select the pin function as follows				
CKE1	0				1
C/\overline{A}	0			1	—
CKE0	0		1	—	—
$P9_5DDR$	0	1	—	—	—
Pin function	$P9_5$ input	$P9_5$ output	SCK_1 output	SCK_1 output	SCK_1 input
	\overline{IRQ}_5 input				
$P9_4/SCK_0/\overline{IRQ}_4$	Bit C/\overline{A} in SMR of SCI0, bits CKE0 and CKE1 in SCR of SCI0, and bit $P9_4DDR$ select the pin function as follows				
CKE1	0				1
C/\overline{A}	0			1	—
CKE0	0		1	—	—
$P9_4DDR$	0	1	—	—	—
Pin function	$P9_4$ input	$P9_4$ output	SCK_0 output	SCK_0 output	SCK_0 input
	\overline{IRQ}_4 input				
$P9_3/RxD_1$	Bit RE in SCR of SCI1 and bit $P9_3DDR$ select the pin function as follows				
RE	0			1	
$P9_3DDR$	0		1		—
Pin function	$P9_3$ input		$P9_3$ output		RxD_1 input
$P9_2/RxD_0$	Bit RE in SCR of SCI0, bit SMIF in SCMR, and bit $P9_2DDR$ select the pin function as follows				
SMIF	0				1
RE	0			1	
$P9_2DDR$	0		1		—
Pin function	$P9_2$ input	$P9_2$ output	RxD_0 input	RxD_0 input	

Pin Pin Functions and Selection MethodP9₁/TxD₁Bit TE in SCR of SCI1 and bit P9₁DDR select the pin function as follows

TE	0		1
P9 ₁ DDR	0	1	—
Pin function	P9 ₁ input	P9 ₁ output	TxD ₁ output

P9₀/TxD₀Bit TE in SCR of SCI0, bit SMIF in SCMR, and bit P9₀DDR select the pin function as follows

SMIF	0			1
TE	0		1	—
P9 ₀ DDR	0	1	—	—
Pin function	P9 ₀ input	P9 ₀ output	TxD ₀ output	TxD ₀ output*

Note: * Functions as the TxD₀ output pin, but there are two states: one in which the pin is driven, and another in which the pin is at high-impedance.

9.11 Port A

9.11.1 Overview

Port A is an 8-bit input/output port that is also used for output (TP₇ to TP₀) from the programmable timing pattern controller (TPC), input and output (TIOCB₂, TIOCA₂, TIOCB₁, TIOCA₁, TIOCB₀, TIOCA₀, TCLKD, TCLKC, TCLKB, TCLKA) by the 16-bit integrated timer unit (ITU), output ($\overline{\text{TEND}}_1$, $\overline{\text{TEND}}_0$) from the DMA controller (DMAC), $\overline{\text{CS}}_4$ to $\overline{\text{CS}}_6$ output, and address output (A₂₃ to A₂₀). A reset or hardware standby leaves port A as an input port, except that in modes 3, 4, and 6, one pin is always used for A₂₀ output. For selecting the pin function, see table 9.19. Usage of pins for TPC, ITU, and DMAC input and output is described in the sections on those modules. For output of address bits A₂₃ to A₂₁ in modes 3, 4, and 6, see section 6.2.5, Bus Release Control Register (BRCR). For output of $\overline{\text{CS}}_4$ to $\overline{\text{CS}}_6$ in modes 1 to 6, see section 6.3.2, Chip Select Signals. Pins not assigned to any of these functions are available for generic input/output. Figure 9.10 shows the pin configuration of port A.

Pins in port A can drive one TTL load and a 30-pF capacitive load. They can also drive a darlington transistor pair. Port A has Schmitt-trigger inputs.

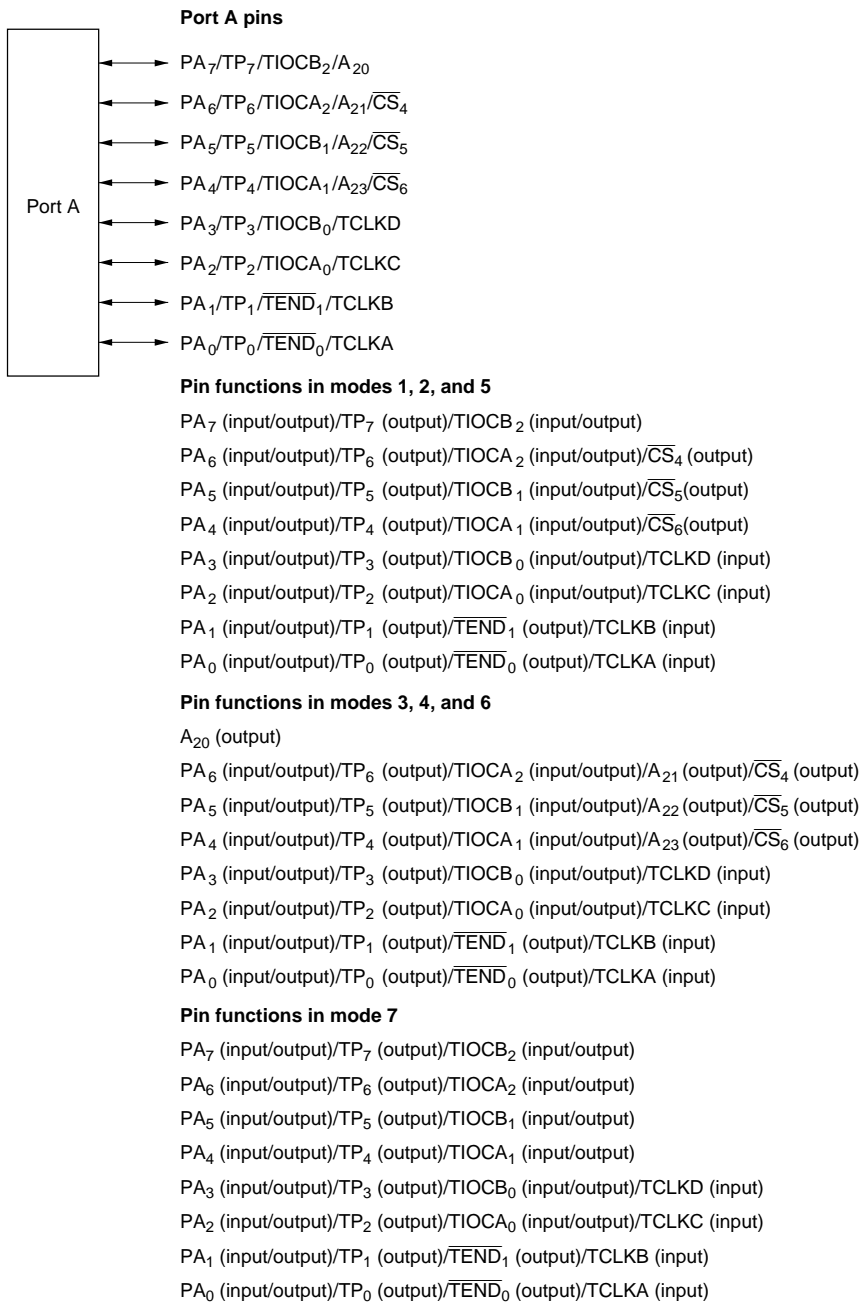

Figure 9.10 Port A Pin Configuration

9.11.2 Register Descriptions

Table 9.18 summarizes the registers of port A.

Table 9.18 Port A Registers

Address*	Name	Abbreviation	R/W	Initial Value	
				Modes 1, 2, 5, and 7	Modes 3, 4, and 6
H'FFD1	Port A data direction register	PADDR	W	H'00	H'80
H'FFD3	Port A data register	PADR	R/W	H'00	H'00

Note: * Lower 16 bits of the address.

Port A Data Direction Register (PADDR)

PADDR is an 8-bit write-only register that can select input or output for each pin in port A. When pins are used for TPC output, the corresponding PADDR bits must also be set.

Bit		7	6	5	4	3	2	1	0
		PA ₇ DDR	PA ₆ DDR	PA ₅ DDR	PA ₄ DDR	PA ₃ DDR	PA ₂ DDR	PA ₁ DDR	PA ₀ DDR
Modes 3, 4, and 6	Initial value	1	0	0	0	0	0	0	0
	Read/Write	—	W	W	W	W	W	W	W
Modes 1, 2, 5, and 7	Initial value	0	0	0	0	0	0	0	0
	Read/Write	W	W	W	W	W	W	W	W

Port A data direction 7 to 0

These bits select input or output for port A pins

While port A acts as an I/O port, a pin in port A becomes an output pin if the corresponding PADDR bit is set to 1, and an input pin if this bit is cleared to 0. In modes 3, 4, and 6, PA₇DDR is fixed at 1 and PA₇ functions as an address output pin.

PADDR is a write-only register. Its value cannot be read. All bits return 1 when read.

PADDR is initialized to H'00 by a reset and in hardware standby mode in modes 1, 2, 5, and 7.

It is initialized to H'80 by a reset and in hardware standby mode in modes 3, 4, and 6. In software standby mode it retains its previous setting. If a PADDR bit is set to 1, the corresponding pin maintains its output state in software standby mode.

Port A Data Register (PADR)

PADR is an 8-bit readable/writable register that stores output data for pins PA₇ to PA₀. While port A acts as an output port, the value of this register is output. When a bit in PADDR is set to 1, if port A is read the value of the corresponding PADR bit is returned. When a bit in PADDR is cleared to 0, if port A is read the corresponding pin level is read.

Bit	7	6	5	4	3	2	1	0
	PA ₇	PA ₆	PA ₅	PA ₄	PA ₃	PA ₂	PA ₁	PA ₀
Initial value	0	0	0	0	0	0	0	0
Read/Write	R/W	R/W	R/W	R/W	R/W	R/W	R/W	R/W

Port A data 7 to 0

These bits store data for port A pins

PADR is initialized to H'00 by a reset and in hardware standby mode. In software standby mode it retains its previous setting.

9.11.3 Pin Functions

Table 9.19 describes the selection of pin functions.

Table 9.19 Port A Pin Functions

Pin Pin Functions and Selection Method

PA_7/TP_7 /
 $TIOCB_2/A_{20}$ The mode setting, ITU channel 2 settings (bit PWM2 in TMDR and bits IOB2 to IOB0 in TIOR2), bit NDER7 in NDERA, and bit PA_7 DDR in PADDR select the pin function as follows

Mode	1, 2, 5, 7			3, 4, 6	
ITU channel 2 settings	(1) in table below	(2) in table below			—
PA_7 DDR	—	0	1	1	—
NDER7	—	—	0	1	—
Pin function	$TIOCB_2$ output	PA_7 input	PA_7 output	TP_7 output	A_{20} output
		$TIOCB_2$ input*			

Note: * $TIOCB_2$ input when IOB2 = 1 and PWM2 = 0.

ITU channel 2 settings	(2)	(1)		(2)
IOB2	0			1
IOB1	0	0	1	—
IOB0	0	1	—	—

Pin Pin Functions and Selection Method

PA₆/TP₆/
TIOCA₂/
A₂₁/CS₄ The mode setting, bit A₂₁E in BRCCR, bit CS4E in CSCCR, ITU channel 2 settings (bit PWM2 in TMDR and bits IOA2 to IOA0 in TIOR2), bit NDER6 in NDERA, and bit PA₆DDR in PADDR select the pin function as follows

Mode	1, 2, 5				3, 4, 6				7						
CS4E	0			1	0			1	—						
A ₂₁ E	—			—	1			0	—			—			
ITU channel 2 settings	(1) in table below	(2) in table below			—	(1) in table below	(2) in table below		—	—	(1) in table below	(2) in table below			
PA ₆ DDR	—	0	1	1	—	—	0	1	1	—	—	—	0	1	1
NDER6	—	—	0	1	—	—	—	0	1	—	—	—	—	0	1
Pin function	TIOCA ₂ output	PA ₆ input	PA ₆ output	TP ₆ output	CS ₄ output	TIOCA ₂ output	PA ₆ input	PA ₆ output	TP ₆ output	A ₂₁ output	CS ₄ output	TIOCA ₂ output	PA ₆ input	PA ₆ output	TP ₆ output
		TIOCA ₂ input*					TIOCA ₂ input*						TIOCA ₂ input*		

Note: * TIOCA₂ input when IOA2 = 1.

ITU channel 2 settings	(2)	(1)			(2)	(1)
PWM2	0				1	
IOA2	0			1		—
IOA1	0	0	1		—	—
IOA0	0	1	—		—	—

Pin Pin Functions and Selection Method

PA₅/TP₅/
TIOCB₁/
A₂₂/ $\overline{\text{CS}}_5$

The mode setting, bit A₂₂E in BR CR, bit CS5E in CSCR, ITU channel 1 settings (bit PWM1 in TMDR and bits IOB2 to IOB0 in TIOR1), bit NDER5 in NDERA, and bit PA₅DDR in PADDR select the pin function as follows

Mode	1, 2, 5					3, 4, 6					7				
CS5E	0			1		0			1		—				
A ₂₂ E	—			—		1			0		—				
ITU channel 1 settings	(1) in table below	(2) in table below			—	(1) in table below	(2) in table below			—	—	(1) in table below	(2) in table below		
PA ₅ DDR	—	0	1	1	—	—	0	1	1	—	—	—	0	1	1
NDER5	—	—	0	1	—	—	—	0	1	—	—	—	—	0	1
Pin function	TIOCB ₁ output	PA ₅ input	PA ₅ output	TP ₅ output	$\overline{\text{CS}}_5$ output	TIOCB ₁ output	PA ₅ input	PA ₅ output	TP ₅ output	A ₂₂ output	$\overline{\text{CS}}_5$ output	TIOCB ₁ output	PA ₅ input	PA ₅ output	TP ₅ output
		TIOCB ₁ input*			TIOCB ₁ input*			TIOCB ₁ input*							

Note: * TIOCB₁ input when IOB2 = 1 and PWM1 = 0.

ITU channel 1 settings	(2)			(1)					(2)		
IOB2	0					1					
IOB1	0			0		1			—		
IOB0	0			1		—			—		

Pin Pin Functions and Selection Method

PA₄/TP₄/
TIOCA₁/
A₂₃/CS₆ The mode setting, bit A₂₃E in BRCCR, bit CS6E in CSCR, ITU channel 1 settings (bit PWM1 in TMDR and bits IOA2 to IOA0 in TIOR1), bit NDER4 in NDERA, and bit PA₄DDR in PADDR select the pin function as follows

Mode	1, 2, 5				3, 4, 6				7						
CS6E	0			1	0			1	—						
A ₂₃ E	—				—	1		0	—		—				
ITU channel 2 settings	(1) in table below	(2) in table below			—	(1) in table below	(2) in table below		—	—	(1) in table below	(2) in table below			
PA ₄ DDR	—	0	1	1	—	—	0	1	1	—	—	—	0	1	1
NDER4	—	—	0	1	—	—	—	0	1	—	—	—	—	0	1
Pin function	TIOCA ₁ output	PA ₄ input	PA ₄ output	TP ₄ output	CS ₆ output	TIOCA ₁ output	PA ₄ input	PA ₄ output	TP ₄ output	A ₂₃ output	CS ₆ output	TIOCA ₁ output	PA ₄ input	PA ₄ output	TP ₄ output
		TIOCA ₁ input*					TIOCA ₁ input*						TIOCA ₁ input*		

Note: * TIOCA1 input when IOA2 = 1.

ITU channel 1 settings	(2)	(1)			(2)	(1)
PWM1	0					1
IOA2	0			1		—
IOA1	0	0	1		—	—
IOA0	0	1	—		—	—

Pin Pin Functions and Selection Method

PA₃/TP₃/
TIOCB₀/
TCLKD

ITU channel 0 settings (bit PWM0 in TMDR and bits IOB2 to IOB0 in TIOR0), bits TPSC2 to TPSC0 in TCR4 to TCR0, bit NDER3 in NDERA, and bit PA₃DDR in PADDR select the pin function as follows

ITU channel 0 settings	(1) in table below	(2) in table below		
PA ₃ DDR	—	0	1	1
NDER3	—	—	0	1
Pin function	TIOCB ₀ output	PA ₃ input	PA ₃ output	TP ₃ output
		TIOCB ₀ input* ¹		
	TCLKD input* ²			

Notes: 1. TIOCB₀ input when IOB2 = 1 and PWM0 = 0.

2. TCLKD input when TPSC2 = TPSC1 = TPSC0 = 1 in any of TCR4 to TCR0.

ITU channel 0 settings	(2)	(1)		(2)
IOB2		0		1
IOB1	0	0	1	—
IOB0	0	1	—	—

Pin Pin Functions and Selection Method

PA₂/TP₂/
TIOCA₀/
TCLKC

ITU channel 0 settings (bit PWM0 in TMDR and bits IOA2 to IOA0 in TIOR0), bits TPSC2 to TPSC0 in TCR4 to TCR0, bit NDER2 in NDERA, and bit PA₂DDR in PADDR select the pin function as follows

ITU channel 0 settings	(1) in table below	(2) in table below		
PA ₂ DDR	—	0	1	1
NDER2	—	—	0	1
Pin function	TIOCA ₀ output	PA ₂ input	PA ₂ output	TP ₂ output
		TIOCA ₀ input* ¹		
	TCLKC input* ²			

Notes: 1. TIOCA₀ input when IOA2 = 1.

2. TCLKC input when TPSC2 = TPSC1 = 1 and TPSC0 = 0 in any of TCR4 to TCR0.

ITU channel 0 settings	(2)	(1)		(2)	(1)
PWM0	0				1
IOA2	0			1	—
IOA1	0	0	1	—	—
IOA0	0	1	—	—	—

Pin Pin Functions and Selection Method

PA_i/TP_i/
TCLKB/
 $\overline{\text{TEND}}_1$

DMAC channel 1 settings (bits DTS2A to DTS0A and DTS2B to DTS0B in DTCR1A and DTCR1B), bit NDER1 in NDERA, and bit PA_iDDR in PADDR select the pin function as follows

DMAC channel 1 settings	(1) in table below	(2) in table below		
PA _i DDR	—	0	1	1
NDER1	—	—	0	1
Pin function	$\overline{\text{TEND}}_1$ output	PA _i input	PA _i output	TP _i output
	TCLKB input*			

Note: * TCLKB input when MDF = 1 in TMDR, or when TPSC2 = 1, TPSC1 = 0, and TPSC0 = 1 in any of TCR4 to TCR0.

DMAC channel 1 settings	(2)		(1)	(2)	(1)	(2)		(1)
DTS2A, DTS1A	Not both 1			Both 1				
DTS0A	—			0	0	1	1	1
DTS2B	0	1	1	0	1	0	1	1
DTS1B	—	0	1	—	—	—	0	1

Pin Pin Functions and Selection Method

PA₀/TP₀/
TCLKA/
 $\overline{\text{TEND}}_0$

DMAC channel 0 settings (bits DTS2A to DTS0A and DTS2B to DTS0B in DTCR0A and DTCR0B), bit NDER0 in NDERA, and bit PA₀DDR in PADDR select the pin function as follows

DMAC channel 0 settings	(1) in table below		(2) in table below		
PA ₀ DDR	—		0	1	1
NDER0	—		—	0	1
Pin function	$\overline{\text{TEND}}_0$ output		PA ₀ input	PA ₀ output	TP ₀ output
	TCLKA input*				

Note: * TCLKA input when MDF = 1 in TMDR, or when TPSC2 = 1 and TPSC1 = 0 in any of TCR4 to TCR0.

DMAC channel 0 settings	(2)		(1)	(2)	(1)	(2)		(1)
DTS2A, DTS1A	Not both 1			Both 1				
DTS0A	—			0	0	1	1	1
DTS2B	0	1	1	0	1	0	1	1
DTS1B	—	0	1	—	—	—	0	1

9.12 Port B

9.12.1 Overview

Port B is an 8-bit input/output port that is also used for output (TP_{15} to TP_8) from the programmable timing pattern controller (TPC), input/output ($TIOCB_4$, $TIOCB_3$, $TIOCA_4$, $TIOCA_3$) and output ($TOCXB_4$, $TOCXA_4$) by the 16-bit integrated timer unit (ITU), input ($\overline{DREQ_1}$, $\overline{DREQ_0}$) to the DMA controller (DMAC), \overline{ADTRG} input to the A/D converter, and $\overline{CS_7}$ output. A reset or hardware standby leaves port B as an input port. For selecting the pin function, see table 9.21. Usage of pins for TPC, ITU, DMAC, and A/D converter input and output is described in the sections on those modules. For output of $\overline{CS_7}$ in modes 1 to 6, see section 6.3.2, Chip Select Signals. Pins not assigned to any of these functions are available for generic input/output. Figure 9.11 shows the pin configuration of port B.

Pins in port B can drive one TTL load and a 30-pF capacitive load. They can also drive an LED or darlington transistor pair. Pins PB_3 to PB_0 have Schmitt-trigger inputs.

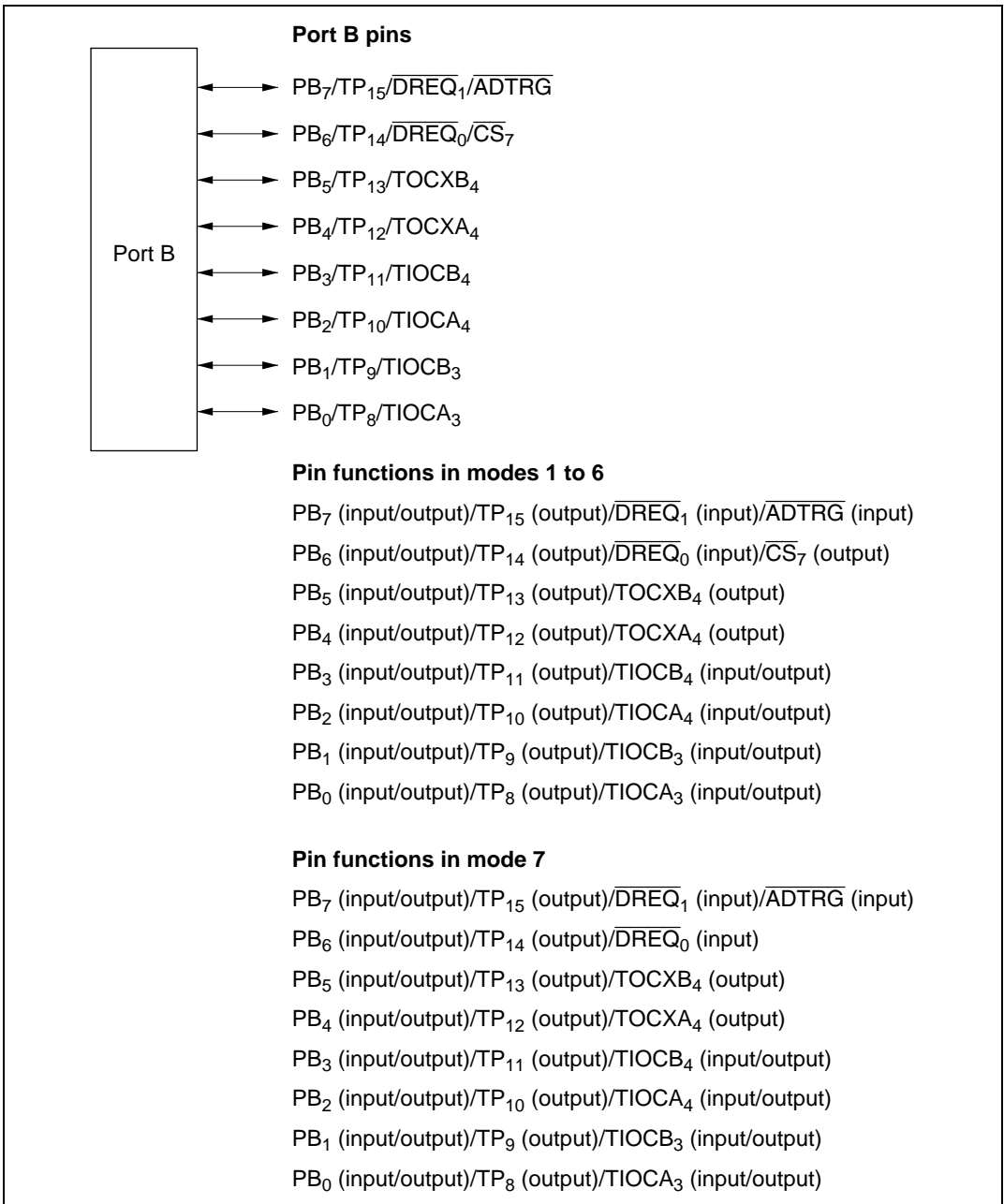

Figure 9.11 Port B Pin Configuration

9.12.2 Register Descriptions

Table 9.20 summarizes the registers of port B.

Table 9.20 Port B Registers

Address*	Name	Abbreviation	R/W	Initial Value
H'FFD4	Port B data direction register	PBDDR	W	H'00
H'FFD6	Port B data register	PBDR	R/W	H'00

Note: * Lower 16 bits of the address.

Port B Data Direction Register (PBDDR)

PBDDR is an 8-bit write-only register that can select input or output for each pin in port B. When pins are used for TPC output, the corresponding PBDDR bits must also be set.

Bit	7	6	5	4	3	2	1	0
	PB ₇ DDR	PB ₆ DDR	PB ₅ DDR	PB ₄ DDR	PB ₃ DDR	PB ₂ DDR	PB ₁ DDR	PB ₀ DDR
Initial value	0	0	0	0	0	0	0	0
Read/Write	W	W	W	W	W	W	W	W

Port B data direction 7 to 0

These bits select input or output for port B pins

While port B acts as an I/O port, a pin in port B becomes an output pin if the corresponding PBDDR bit is set to 1, and an input pin if this bit is cleared to 0.

PBDDR is a write-only register. Its value cannot be read. All bits return 1 when read.

PBDDR is initialized to H'00 by a reset and in hardware standby mode. In software standby mode it retains its previous setting. If a PBDDR bit is set to 1 while port B acts as an I/O port, the corresponding pin maintains its output state in software standby mode.

Port B Data Register (PBDR)

PBDR is an 8-bit readable/writable register that stores output data for pins PB7 to PB0. While port B acts as an output port, the value of this register is output. When a bit in PBDDR is set to 1, if port B is read the value of the corresponding PBDR bit is returned. When a bit in PBDDR is cleared to 0, if port B is read the corresponding pin level is read.

Bit	7	6	5	4	3	2	1	0
	PB ₇	PB ₆	PB ₅	PB ₄	PB ₃	PB ₂	PB ₁	PB ₀
Initial value	0	0	0	0	0	0	0	0
Read/Write	R/W	R/W	R/W	R/W	R/W	R/W	R/W	R/W

Port B data 7 to 0

These bits store data for port B pins

PBDR is initialized to H'00 by a reset and in hardware standby mode. In software standby mode it retains its previous setting.

9.12.3 Pin Functions

Table 9.21 describes the selection of pin functions.

Table 9.21 Port B Pin Functions

Pin	Pin Functions and Selection Method		
$\overline{PB_7}/\overline{TP_{15}}/$ $\overline{DREQ_1}/$ \overline{ADTRG}	DMAC channel 1 settings (bits DTS2A to DTS0A and DTS2B to DTS0B in DTCCR1A and DTCCR1B), bit TRGE in ADCR, bit NDER15 in NDERB, and bit $\overline{PB_7}$ in PBDDR select the pin function as follows		
PB ₇ DDR	0	1	1
NDER15	—	0	1
Pin function	PB ₇ input	PB ₇ output	TP ₁₅ output
	$\overline{DREQ_1}$ input* ¹		
	\overline{ADTRG} input* ²		

Notes: 1. $\overline{DREQ_1}$ input under DMAC channel 1 settings (1) in the table below.

2. \overline{ADTRG} input when TRGE = 1.

DMAC channel 1 settings	(2)		(1)	(2)		(1)	(2)		(1)
DTS2A, DTS1A	Not both 1			Both 1					
DTS0A	—			0	0	1	1	1	1
DTS2B	0	1	1	0	1	0	1	1	1
DTS1B	—	0	1	—	—	—	0	1	1

Pin Pin Functions and Selection Method

$PB_6/TP_{14}/\overline{DREQ}_0/\overline{CS}_7$ Bit CS7E in CSCR, DMAC channel 0 settings (bits DTS2A to DTS0A and DTS2B to DTS0B in DTCR0A and DTCR0B), bit NDER14 in NDERB, and bit PB_6 DDR in PBDDR select the pin function as follows

PB_6 DDR	0	1	1	—
CS7E	0	0	0	1
NDER14	—	0	1	—
Pin function	PB_6 input	PB_6 output	TP_{14} output	—
	\overline{DREQ}_0 input*			\overline{CS}_7 output

Note: * \overline{DREQ}_0 input under DMAC channel 0 settings (1) in the table below.

DMAC channel 0 settings	(2)		(1)	(2)	(1)	(2)		(1)
DTS2A, DTS1A	Not both 1			Both 1				
DTS0A	—			0	0	1	1	1
DTS2B	0	1	1	0	1	0	1	1
DTS1B	—	0	1	—	—	—	0	1

$PB_5/TP_{13}/TOCXB_4$ ITU channel 4 settings (bit CMD1 in TFCR and bit EXB4 in TOER), bit NDER13 in NDERB, and bit PB_5 DDR in PBDDR select the pin function as follows

EXB4, CMD1	Not both 1			Both 1	
PB_5 DDR	0	1	1	—	
NDER13	—	0	1	—	
Pin function	PB_5 input	PB_5 output	TP_{13} output	$TOCXB_4$ output	

$PB_4/TP_{12}/TOCXA_4$ ITU channel 4 settings (bit CMD1 in TFCR and bit EXA4 in TOER), bit NDER12 in NDERB, and bit PB_4 DDR in PBDDR select the pin function as follows

EXA4, CMD1	Not both 1			Both 1	
PB_4 DDR	0	1	1	—	
NDER12	—	0	1	—	
Pin function	PB_4 input	PB_4 output	TP_{12} output	$TOCXA_4$ output	

Pin Pin Functions and Selection Method

PB₃/TP₁₁/
TIOCB₄ ITU channel 4 settings (bit PWM4 in TMDR, bit CMD1 in TFCR, bit EB4 in TOER, and bits IOB2 to IOB0 in TIOR4), bit NDER11 in NDERB, and bit PB₃DDR in PBDDR select the pin function as follows

ITU channel 4 settings	(1) in table below	(2) in table below		
PB ₃ DDR	—	0	1	1
NDER11	—	—	0	1
Pin function	TIOCB ₄ output	PB ₃ input	PB ₃ output	TP ₁₁ output
		TIOCB ₄ input*		

Note: * TIOCB₄ input when CMD1 = PWM4 = 0 and IOB2 = 1.

ITU channel 4 settings	(2)	(2)	(1)		(2)	(1)
EB4	0	1				
CMD1	—	0				1
IOB2	—	0	0	0	1	—
IOB1	—	0	0	1	—	—
IOB0	—	0	1	—	—	—

Pin Pin Functions and Selection Method

PB₂/TP₁₀/
TIOCA₄ ITU channel 4 settings (bit CMD1 in TFCR, bit EA4 in TOER, bit PWM4 in TMDR, and bits IOA2 to IOA0 in TIOR4), bit NDER10 in NDERB, and bit PB₂DDR in PBDDR select the pin function as follows

ITU channel 4 settings	(1) in table below	(2) in table below		
PB ₂ DDR	—	0	1	1
NDER10	—	—	0	1
Pin function	TIOCA ₄ output	PB ₂ input	PB ₂ output	TP ₁₀ output
		TIOCA ₄ input*		

Note: * TIOCA₄ input when CMD1 = PWM4 = 0 and IOA2 = 1.

ITU channel 4 settings	(2)	(2)	(1)			(2)	(1)	
EA4	0	1						
CMD1	—	0					1	
PWM4	—	0				1	—	
IOA2	—	0	0	0	1	—	—	
IOA1	—	0	0	1	—	—	—	
IOA0	—	0	1	—	—	—	—	

Pin Pin Functions and Selection Method

PB₁/TP₉/
TIOCB₃ ITU channel 3 settings (bit PWM3 in TMDR, bit CMD1 in TFCR, bit EB3 in TOER, and bits IOB2 to IOB0 in TIOR3), bit NDER9 in NDERB, and bit PB₁DDR in PBDDR select the pin function as follows

ITU channel 3 settings	(1) in table below	(2) in table below		
PB ₁ DDR	—	0	1	1
NDER9	—	—	0	1
Pin function	TIOCB ₃ output	PB ₁ input	PB ₁ output	TP ₉ output
		TIOCB ₃ input*		

Note: * TIOCB₃ input when CMD1 = PWM3 = 0 and IOB2 = 1.

ITU channel 3 settings	(2)	(2)	(1)		(2)	(1)
EB3	0	1				
CMD1	—	0				1
IOB2	—	0	0	0	1	—
IOB1	—	0	0	1	—	—
IOB0	—	0	1	—	—	—

Pin Pin Functions and Selection Method

PB₀/TP₈/
TIOCA₃ ITU channel 3 settings (bit CMD1 in TFCR, bit EA3 in TOER, bit PWM3 in TMDR, and bits IOA2 to IOA0 in TIOR3), bit NDER8 in NDERB, and bit PB₀DDR in PBDDR select the pin function as follows

ITU channel 3 settings	(1) in table below	(2) in table below		
PB ₀ DDR	—	0	1	1
NDER8	—	—	0	1
Pin function	TIOCA ₃ output	PB ₀ input	PB ₀ output	TP ₈ output
		TIOCA ₃ input*		

Note: * TIOCA₃ input when CMD1 = PWM3 = 0 and IOA2 = 1.

ITU channel 3 settings	(2)	(2)	(1)		(2)	(1)	
EA3	0	1					
CMD1	—	0				1	
PWM3	—	0			1	—	
IOA2	—	0	0	0	1	—	—
IOA1	—	0	0	1	—	—	—
IOA0	—	0	1	—	—	—	—

Section 10 16-Bit Integrated Timer Unit (ITU)

10.1 Overview

The H8/3048B Group has a built-in 16-bit integrated timer unit (ITU) with five 16-bit timer channels.

When the ITU is not used, it can be independently halted to conserve power. For details see section 20.6, Module Standby Function.

10.1.1 Features

ITU features are listed below.

- Capability to process up to 12 pulse outputs or 10 pulse inputs
- Ten general registers (GRs, two per channel) with independently-assignable output compare or input capture functions
- Selection of eight counter clock sources for each channel:
Internal clocks: ϕ , $\phi/2$, $\phi/4$, $\phi/8$
External clocks: TCLKA, TCLKB, TCLKC, TCLKD
- Five operating modes selectable in all channels:
 - Waveform output by compare match
Selection of 0 output, 1 output, or toggle output (only 0 or 1 output in channel 2)
 - Input capture function
Rising edge, falling edge, or both edges (selectable)
 - Counter clearing function
Counters can be cleared by compare match or input capture
 - Synchronization
Two or more timer counters (TCNTs) can be preset simultaneously, or cleared simultaneously by compare match or input capture. Counter synchronization enables synchronous register input and output.
 - PWM mode
PWM output can be provided with an arbitrary duty cycle. With synchronization, up to five-phase PWM output is possible
- Phase counting mode selectable in channel 2
Two-phase encoder output can be counted automatically.

- Three additional modes selectable in channels 3 and 4
 - Reset-synchronized PWM mode
If channels 3 and 4 are combined, three-phase PWM output is possible with three pairs of complementary waveforms.
 - Complementary PWM mode
If channels 3 and 4 are combined, three-phase PWM output is possible with three pairs of non-overlapping complementary waveforms.
 - Buffering
Input capture registers can be double-buffered. Output compare registers can be updated automatically.
- High-speed access via internal 16-bit bus
The 16-bit timer counters, general registers, and buffer registers can be accessed at high speed via a 16-bit bus.
- Fifteen interrupt sources
Each channel has two compare match/input capture interrupts and an overflow interrupt. All interrupts can be requested independently.
- Activation of DMA controller (DMAC)
Four of the compare match/input capture interrupts from channels 0 to 3 can start the DMAC.
- Output triggering of programmable timing pattern controller (TPC)
Compare match/input capture signals from channels 0 to 3 can be used as TPC output triggers.

Table 10.1 summarizes the ITU functions.

Table 10.1 ITU Functions

Item	Channel 0	Channel 1	Channel 2	Channel 3	Channel 4
Clock sources	Internal clocks: ϕ , $\phi/2$, $\phi/4$, $\phi/8$ External clocks: TCLKA, TCLKB, TCLKC, TCLKD, selectable independently				
General registers (output compare/input capture registers)	GRA0, GRB0	GRA1, GRB1	GRA2, GRB2	GRA3, GRB3	GRA4, GRB4
Buffer registers	—	—	—	BRA3, BRB3	BRA4, BRB4
Input/output pins	TIOCA ₀ , TIOCB ₀	TIOCA ₁ , TIOCB ₁	TIOCA ₂ , TIOCB ₂	TIOCA ₃ , TIOCB ₃	TIOCA ₄ , TIOCB ₄
Output pins	—	—	—	—	TOCXA ₄ , TOCXB ₄
Counter clearing function	GRA0/GRB0 compare match or input capture	GRA1/GRB1 compare match or input capture	GRA2/GRB2 compare match or input capture	GRA3/GRB3 compare match or input capture	GRA4/GRB4 compare match or input capture
Compare match output	0	O	O	O	O
	1	O	O	O	O
	Toggle	O	O	—	O
Input capture function	O	O	O	O	O
Synchronization	O	O	O	O	O
PWM mode	O	O	O	O	O
Reset-synchronized PWM mode	—	—	—	O	O
Complementary PWM mode	—	—	—	O	O
Phase counting mode	—	—	O	—	—
Buffering	—	—	—	O	O
DMAC activation	GRA0 compare match or input capture	GRA1 compare match or input capture	GRA2 compare match or input capture	GRA3 compare match or input capture	—
Interrupt sources	Three sources • tch/input capture A0 • Compare match/input capture B0 • Overflow	Three sources • Compare match/input capture A1 • Compare match/input capture B1 • Overflow	Three sources • Compare match/input capture A2 • Compare match/input capture B2 • Overflow	Three sources • Compare match/input capture A3 • Compare match/input capture B3 • Overflow	Three sources • Compare match/input capture A4 • Compare match/input capture B4 • Overflow

Legend: O: Available

—: Not available

10.1.2 Block Diagrams

ITU Block Diagram (Overall)

Figure 10.1 is a block diagram of the ITU.

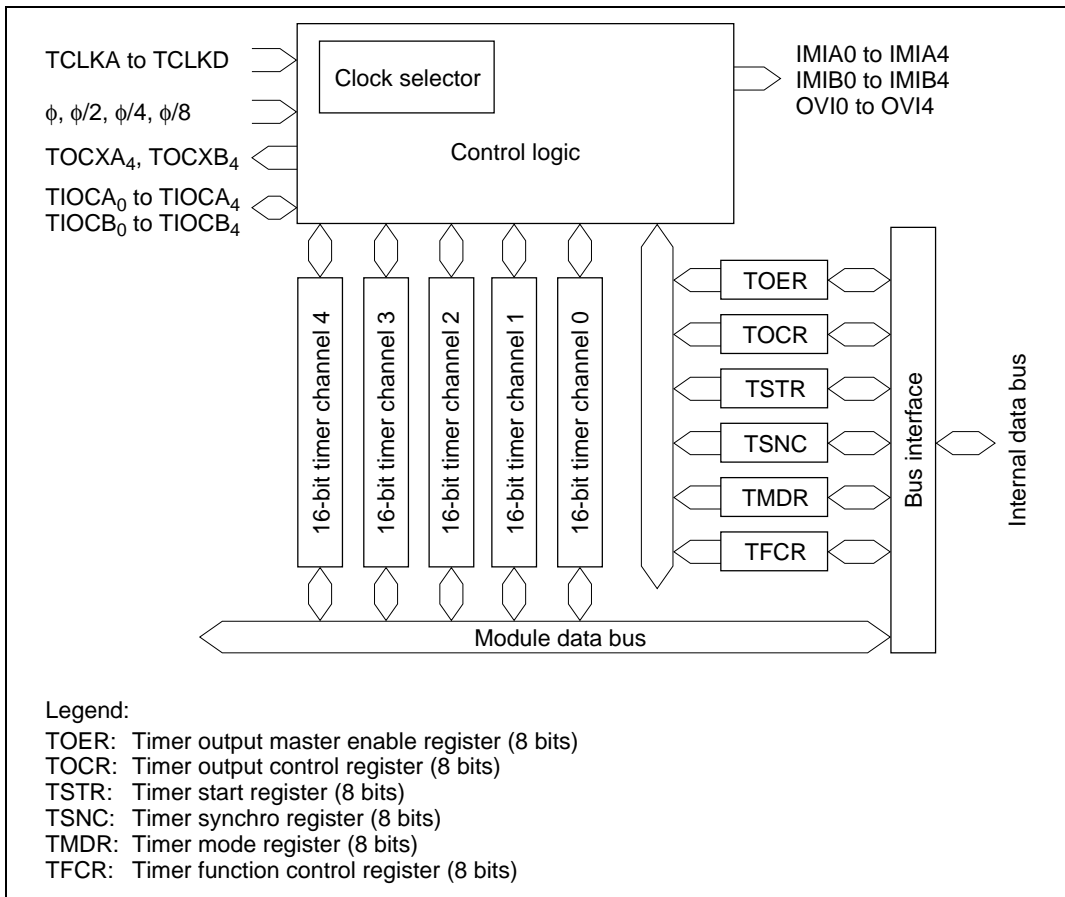

Figure 10.1 ITU Block Diagram (Overall)

Block Diagram of Channels 0 and 1

ITU channels 0 and 1 are functionally identical. Both have the structure shown in figure 10.2.

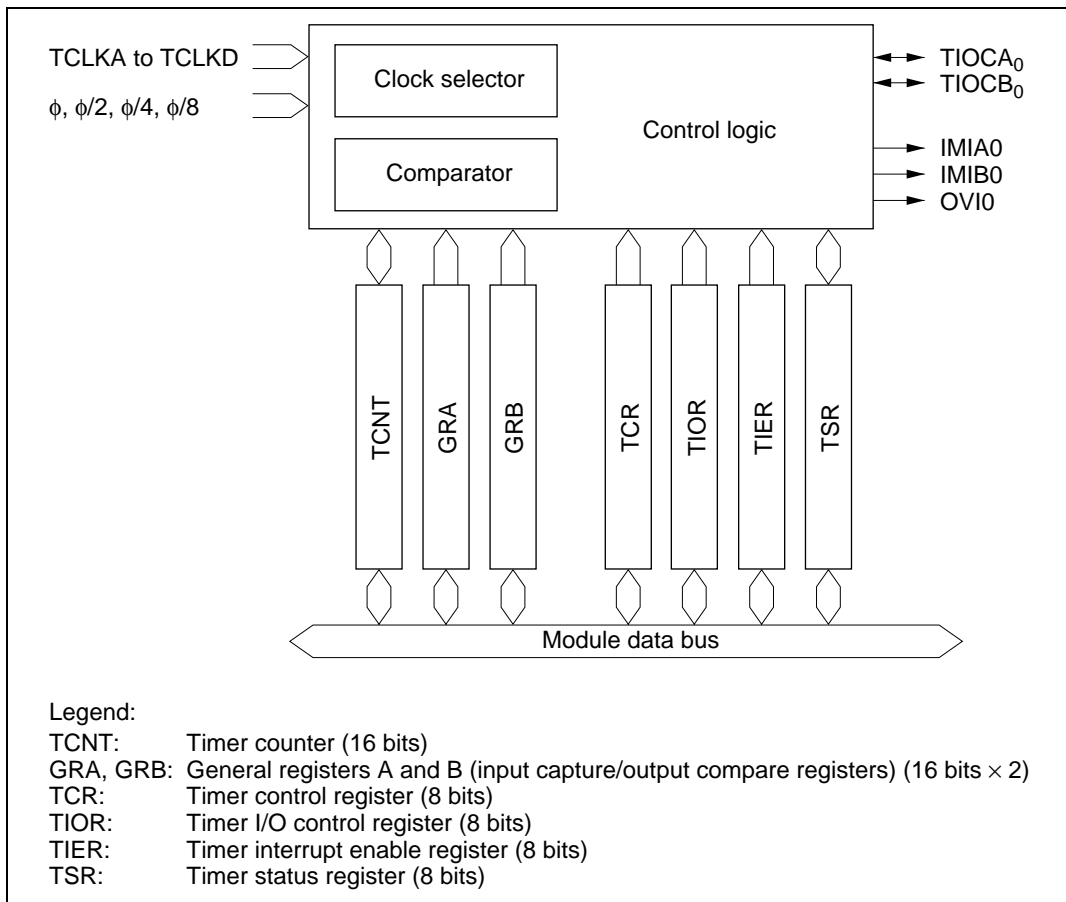

Figure 10.2 Block Diagram of Channels 0 and 1 (for Channel 0)

Block Diagram of Channel 2

Figure 10.3 is a block diagram of channel 2. This is the channel that provides only 0 output and 1 output.

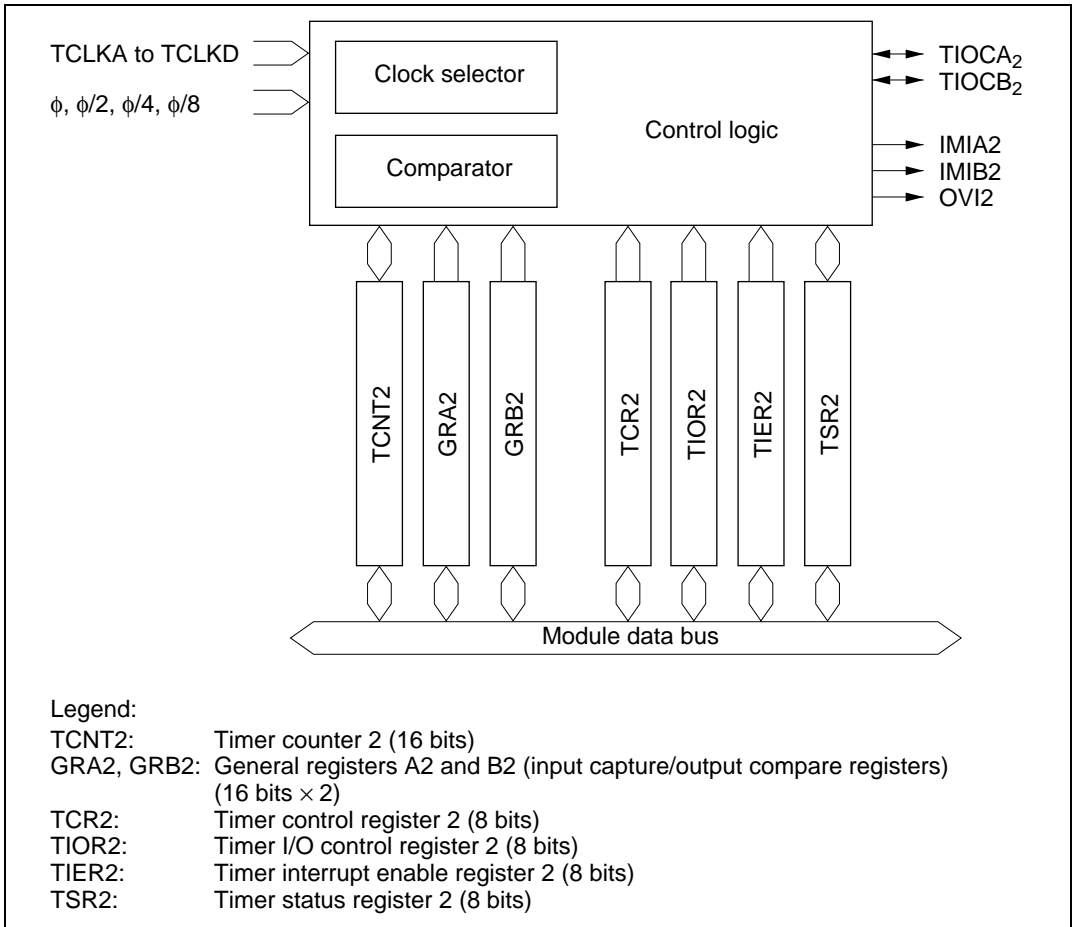

Figure 10.3 Block Diagram of Channel 2

Block Diagrams of Channels 3 and 4

Figure 10.4 is a block diagram of channel 3. Figure 10.5 is a block diagram of channel 4.

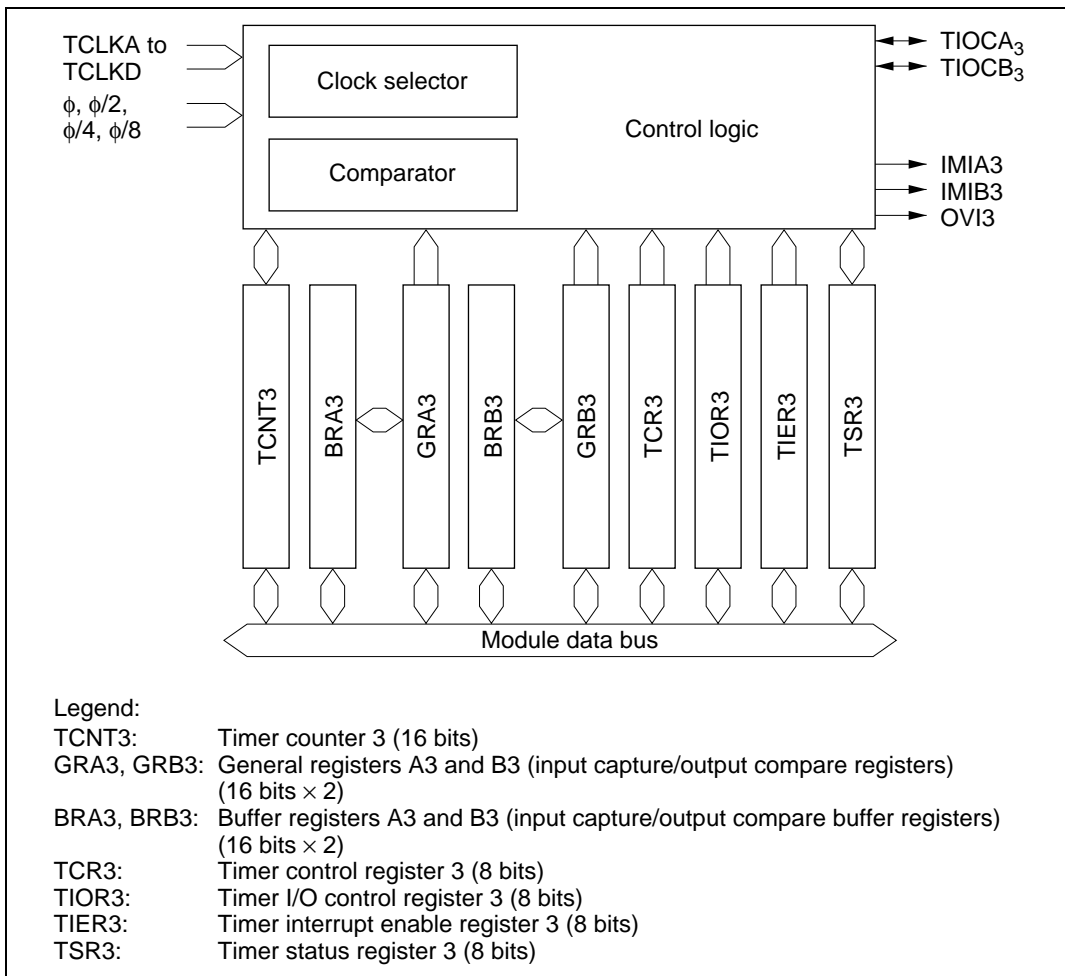

Figure 10.4 Block Diagram of Channel 3

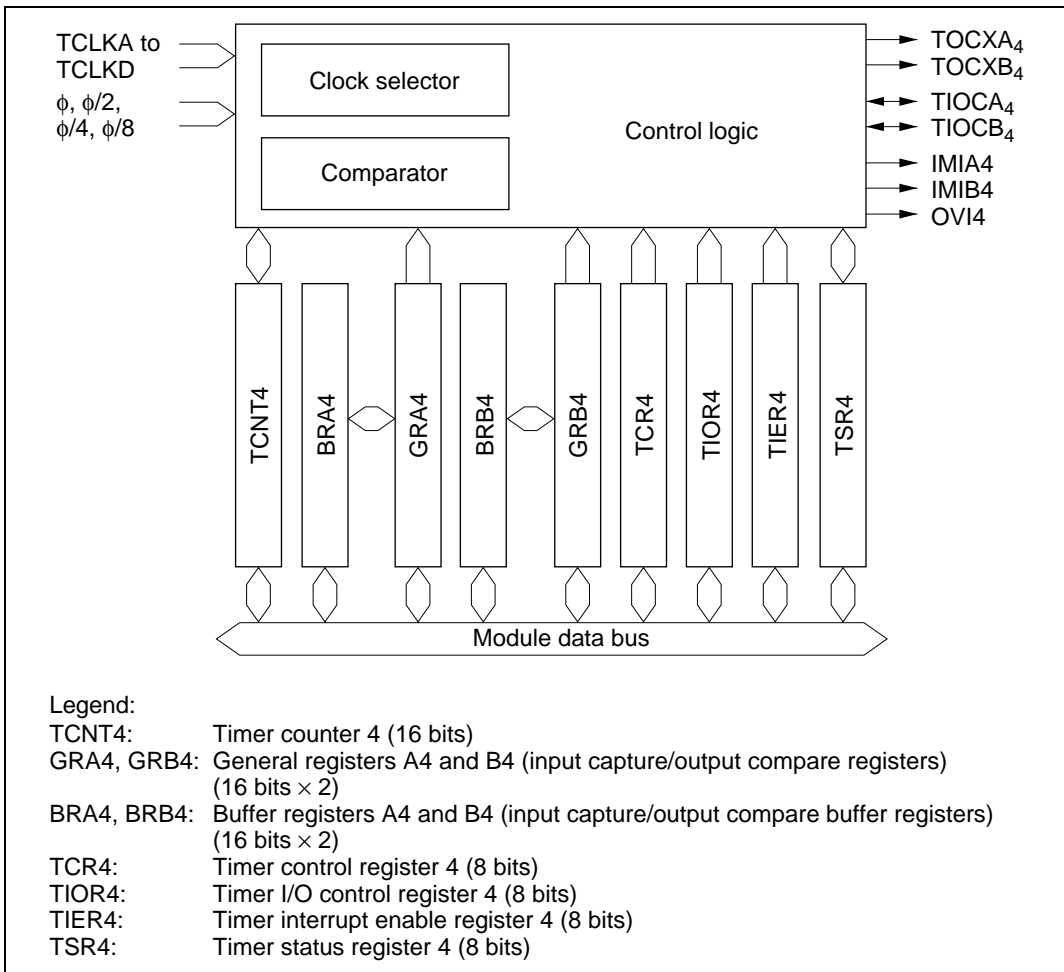

Figure 10.5 Block Diagram of Channel 4

10.1.3 Input/Output Pins

Table 10.2 summarizes the ITU pins.

Table 10.2 ITU Pins

Channel	Name	Abbreviation	Input/Output	Function
Common	Clock input A	TCLKA	Input	External clock A input pin (phase-A input pin in phase counting mode)
	Clock input B	TCLKB	Input	External clock B input pin (phase-B input pin in phase counting mode)
	Clock input C	TCLKC	Input	External clock C input pin
	Clock input D	TCLKD	Input	External clock D input pin
0	Input capture/output compare A0	TIOCA ₀	Input/output	GRA0 output compare or input capture pin PWM output pin in PWM mode
	Input capture/output compare B0	TIOCB ₀	Input/output	GRB0 output compare or input capture pin
1	Input capture/output compare A1	TIOCA ₁	Input/output	GRA1 output compare or input capture pin PWM output pin in PWM mode
	Input capture/output compare B1	TIOCB ₁	Input/output	GRB1 output compare or input capture pin
2	Input capture/output compare A2	TIOCA ₂	Input/output	GRA2 output compare or input capture pin PWM output pin in PWM mode
	Input capture/output compare B2	TIOCB ₂	Input/output	GRB2 output compare or input capture pin
3	Input capture/output compare A3	TIOCA ₃	Input/output	GRA3 output compare or input capture pin PWM output pin in PWM mode, complementary PWM mode, or reset-synchronized PWM mode
	Input capture/output compare B3	TIOCB ₃	Input/output	GRB3 output compare or input capture pin PWM output pin in complementary PWM mode or reset-synchronized PWM mode
4	Input capture/output compare A4	TIOCA ₄	Input/output	GRA4 output compare or input capture pin PWM output pin in PWM mode, complementary PWM mode, or reset-synchronized PWM mode
	Input capture/output compare B4	TIOCB ₄	Input/output	GRB4 output compare or input capture pin PWM output pin in complementary PWM mode or reset-synchronized PWM mode
	Output compare XA4	TOCXA ₄	Output	PWM output pin in complementary PWM mode or reset-synchronized PWM mode
	Output compare XB4	TOCXB ₄	Output	PWM output pin in complementary PWM mode or reset-synchronized PWM mode

10.1.4 Register Configuration

Table 10.3 summarizes the ITU registers.

Table 10.3 ITU Registers

Channel	Address*1	Name	Abbreviation	R/W	Initial Value
Common	H'FF60	Timer start register	TSTR	R/W	H'E0
	H'FF61	Timer synchro register	TSNC	R/W	H'E0
	H'FF62	Timer mode register	TMDR	R/W	H'80
	H'FF63	Timer function control register	TFCR	R/W	H'C0
	H'FF90	Timer output master enable register	TOER	R/W	H'FF
	H'FF91	Timer output control register	TOCR	R/W	H'FF
0	H'FF64	Timer control register 0	TCR0	R/W	H'80
	H'FF65	Timer I/O control register 0	TIOR0	R/W	H'88
	H'FF66	Timer interrupt enable register 0	TIER0	R/W	H'F8
	H'FF67	Timer status register 0	TSR0	R/(W)*2	H'F8
	H'FF68	Timer counter 0 (high)	TCNT0H	R/W	H'00
	H'FF69	Timer counter 0 (low)	TCNT0L	R/W	H'00
	H'FF6A	General register A0 (high)	GRA0H	R/W	H'FF
	H'FF6B	General register A0 (low)	GRA0L	R/W	H'FF
	H'FF6C	General register B0 (high)	GRB0H	R/W	H'FF
	H'FF6D	General register B0 (low)	GRB0L	R/W	H'FF
1	H'FF6E	Timer control register 1	TCR1	R/W	H'80
	H'FF6F	Timer I/O control register 1	TIOR1	R/W	H'88
	H'FF70	Timer interrupt enable register 1	TIER1	R/W	H'F8
	H'FF71	Timer status register 1	TSR1	R/(W)*2	H'F8
	H'FF72	Timer counter 1 (high)	TCNT1H	R/W	H'00
	H'FF73	Timer counter 1 (low)	TCNT1L	R/W	H'00
	H'FF74	General register A1 (high)	GRA1H	R/W	H'FF
	H'FF75	General register A1 (low)	GRA1L	R/W	H'FF
	H'FF76	General register B1 (high)	GRB1H	R/W	H'FF
	H'FF77	General register B1 (low)	GRB1L	R/W	H'FF

Channel	Address*1	Name	Abbreviation	R/W	Initial Value
2	H'FF78	Timer control register 2	TCR2	R/W	H'80
	H'FF79	Timer I/O control register 2	TIOR2	R/W	H'88
	H'FF7A	Timer interrupt enable register 2	TIER2	R/W	H'F8
	H'FF7B	Timer status register 2	TSR2	R/(W)*2	H'F8
	H'FF7C	Timer counter 2 (high)	TCNT2H	R/W	H'00
	H'FF7D	Timer counter 2 (low)	TCNT2L	R/W	H'00
	H'FF7E	General register A2 (high)	GRA2H	R/W	H'FF
	H'FF7F	General register A2 (low)	GRA2L	R/W	H'FF
	H'FF80	General register B2 (high)	GRB2H	R/W	H'FF
	H'FF81	General register B2 (low)	GRB2L	R/W	H'FF
3	H'FF82	Timer control register 3	TCR3	R/W	H'80
	H'FF83	Timer I/O control register 3	TIOR3	R/W	H'88
	H'FF84	Timer interrupt enable register 3	TIER3	R/W	H'F8
	H'FF85	Timer status register 3	TSR3	R/(W)*2	H'F8
	H'FF86	Timer counter 3 (high)	TCNT3H	R/W	H'00
	H'FF87	Timer counter 3 (low)	TCNT3L	R/W	H'00
	H'FF88	General register A3 (high)	GRA3H	R/W	H'FF
	H'FF89	General register A3 (low)	GRA3L	R/W	H'FF
	H'FF8A	General register B3 (high)	GRB3H	R/W	H'FF
	H'FF8B	General register B3 (low)	GRB3L	R/W	H'FF
	H'FF8C	Buffer register A3 (high)	BRA3H	R/W	H'FF
	H'FF8D	Buffer register A3 (low)	BRA3L	R/W	H'FF
	H'FF8E	Buffer register B3 (high)	BRB3H	R/W	H'FF
	H'FF8F	Buffer register B3 (low)	BRB3L	R/W	H'FF

Channel	Address* ¹	Name	Abbreviation	R/W	Initial Value
4	H'FF92	Timer control register 4	TCR4	R/W	H'80
	H'FF93	Timer I/O control register 4	TIOR4	R/W	H'88
	H'FF94	Timer interrupt enable register 4	TIER4	R/W	H'F8
	H'FF95	Timer status register 4	TSR4	R/(W)* ²	H'F8
	H'FF96	Timer counter 4 (high)	TCNT4H	R/W	H'00
	H'FF97	Timer counter 4 (low)	TCNT4L	R/W	H'00
	H'FF98	General register A4 (high)	GRA4H	R/W	H'FF
	H'FF99	General register A4 (low)	GRA4L	R/W	H'FF
	H'FF9A	General register B4 (high)	GRB4H	R/W	H'FF
	H'FF9B	General register B4 (low)	GRB4L	R/W	H'FF
	H'FF9C	Buffer register A4 (high)	BRA4H	R/W	H'FF
	H'FF9D	Buffer register A4 (low)	BRA4L	R/W	H'FF
	H'FF9E	Buffer register B4 (high)	BRB4H	R/W	H'FF
	H'FF9F	Buffer register B4 (low)	BRB4L	R/W	H'FF

- Notes: 1. Lower 16 bits of the address.
 2. Only 0 can be written, to clear flags.

10.2 Register Descriptions

10.2.1 Timer Start Register (TSTR)

TSTR is an 8-bit readable/writable register that starts and stops the timer counter (TCNT) in channels 0 to 4.

Bit	7	6	5	4	3	2	1	0
	—	—	—	STR4	STR3	STR2	STR1	STR0
Initial value	1	1	1	0	0	0	0	0
Read/Write	—	—	—	R/W	R/W	R/W	R/W	R/W

Reserved bits
Counter start 4 to 0
 These bits start and stop TCNT4 to TCNT0

TSTR is initialized to H'E0 by a reset and in standby mode.

Bits 7 to 5—Reserved: Read-only bits, always read as 1.

Bit 4—Counter Start 4 (STR4): Starts and stops timer counter 4 (TCNT4).

Bit 4: STR4	Description
0	TCNT4 is halted (Initial value)
1	TCNT4 is counting

Bit 3—Counter Start 3 (STR3): Starts and stops timer counter 3 (TCNT3).

Bit 3: STR3	Description
0	TCNT3 is halted (Initial value)
1	TCNT3 is counting

Bit 2—Counter Start 2 (STR2): Starts and stops timer counter 2 (TCNT2).

Bit 2: STR2	Description
0	TCNT2 is halted (Initial value)
1	TCNT2 is counting

Bit 1—Counter Start 1 (STR1): Starts and stops timer counter 1 (TCNT1).

Bit 1: STR1	Description	
0	TCNT1 is halted	(Initial value)
1	TCNT1 is counting	

Bit 0—Counter Start 0 (STR0): Starts and stops timer counter 0 (TCNT0).

Bit 0: STR0	Description	
0	TCNT0 is halted	(Initial value)
1	TCNT0 is counting	

10.2.2 Timer Synchro Register (TSNC)

TSNC is an 8-bit readable/writable register that selects whether channels 0 to 4 operate independently or synchronously. Channels are synchronized by setting the corresponding bits to 1.

Bit	7	6	5	4	3	2	1	0
	—	—	—	SYNC4	SYNC3	SYNC2	SYNC1	SYNC0
Initial value	1	1	1	0	0	0	0	0
Read/Write	—	—	—	R/W	R/W	R/W	R/W	R/W

Reserved bits
Timer sync 4 to 0
These bits synchronize channels 4 to 0

TSNC is initialized to H'E0 by a reset and in standby mode.

Bits 7 to 5—Reserved: Read-only bits, always read as 1.

Bit 4—Timer Sync 4 (SYNC4): Selects whether channel 4 operates independently or synchronously.

Bit 4: SYNC4	Description	
0	Channel 4's timer counter (TCNT4) operates independently TCNT4 is preset and cleared independently of other channels	(Initial value)
1	Channel 4 operates synchronously TCNT4 can be synchronously preset and cleared	

Bit 3—Timer Sync 3 (SYNC3): Selects whether channel 3 operates independently or synchronously.

Bit 3: SYNC3	Description
0	Channel 3's timer counter (TCNT3) operates independently (Initial value) TCNT3 is preset and cleared independently of other channels
1	Channel 3 operates synchronously TCNT3 can be synchronously preset and cleared

Bit 2—Timer Sync 2 (SYNC2): Selects whether channel 2 operates independently or synchronously.

Bit 2: SYNC2	Description
0	Channel 2's timer counter (TCNT2) operates independently (Initial value) TCNT2 is preset and cleared independently of other channels
1	Channel 2 operates synchronously TCNT2 can be synchronously preset and cleared

Bit 1—Timer Sync 1 (SYNC1): Selects whether channel 1 operates independently or synchronously.

Bit 1: SYNC1	Description
0	Channel 1's timer counter (TCNT1) operates independently (Initial value) TCNT1 is preset and cleared independently of other channels
1	Channel 1 operates synchronously TCNT1 can be synchronously preset and cleared

Bit 0—Timer Sync 0 (SYNC0): Selects whether channel 0 operates independently or synchronously.

Bit 0: Bit 0	Description
0	Channel 0's timer counter (TCNT0) operates independently (Initial value) TCNT0 is preset and cleared independently of other channels
1	Channel 0 operates synchronously TCNT0 can be synchronously preset and cleared

10.2.3 Timer Mode Register (TMDR)

TMDR is an 8-bit readable/writable register that selects PWM mode for channels 0 to 4. It also selects phase counting mode and the overflow flag (OVF) setting conditions for channel 2.

Bit	7	6	5	4	3	2	1	0
	—	MDF	FDIR	PWM4	PWM3	PWM2	PWM1	PWM0
Initial value	1	0	0	0	0	0	0	0
Read/Write	—	R/W	R/W	R/W	R/W	R/W	R/W	R/W

Reserved bit
 Bit 7 is a reserved bit.

Phase counting mode flag
 Selects phase counting mode for channel 2.

Flag direction
 Selects the setting condition for the overflow flag (OVF) in timer status register 2 (TSR2).

PWM mode 4 to 0
 These bits select PWM mode for channels 4 to 0.

TMDR is initialized to H'80 by a reset and in standby mode.

Bit 7—Reserved: Read-only bit, always read as 1.

Bit 6—Phase Counting Mode Flag (MDF): Selects whether channel 2 operates normally or in phase counting mode.

Bit 6: MDF	Description
0	Channel 2 operates normally (Initial value)
1	Channel 2 operates in phase counting mode

When MDF is set to 1 to select phase counting mode, TCNT2 operates as an up/down-counter and pins TCLKA and TCLKB become counter clock input pins. TCNT2 counts both rising and falling edges of TCLKA and TCLKB, and counts up or down as follows.

Counting Direction	Down-Counting				Up-Counting			
TCLKA pin	↑	High	↓	Low	↑	Low	↓	High
TCLKB pin	Low	↑	High	↓	High	↑	Low	↓

In phase counting mode channel 2 operates as above regardless of the external clock edges selected by bits CKEG1 and CKEG0 and the clock source selected by bits TPSC2 to TPSC0 in TCR2. Phase counting mode takes precedence over these settings.

The counter clearing condition selected by the CCLR1 and CCLR0 bits in TCR2 and the compare match/input capture settings and interrupt functions of TIOR2, TIER2, and TSR2 remain effective in phase counting mode.

Bit 5—Flag Direction (FDIR): Designates the setting condition for the OVF flag in TSR2. The FDIR designation is valid in all modes in channel 2.

Bit 5: FDIR	Description
0	OVF is set to 1 in TSR2 when TCNT2 overflows or underflows (Initial value)
1	OVF is set to 1 in TSR2 when TCNT2 overflows

Bit 4—PWM Mode 4 (PWM4): Selects whether channel 4 operates normally or in PWM mode.

Bit 4: PWM4	Description
0	Channel 4 operates normally (Initial value)
1	Channel 4 operates in PWM mode

When bit PWM4 is set to 1 to select PWM mode, pin TIOCA₄ becomes a PWM output pin. The output goes to 1 at compare match with GRA4, and to 0 at compare match with GRB4.

If complementary PWM mode or reset-synchronized PWM mode is selected by bits CMD1 and CMD0 in TFCR, the CMD1 and CMD0 setting takes precedence and the PWM4 setting is ignored.

Bit 3—PWM Mode 3 (PWM3): Selects whether channel 3 operates normally or in PWM mode.

Bit 3: PWM3	Description	
0	Channel 3 operates normally	(Initial value)
1	Channel 3 operates in PWM mode	

When bit PWM3 is set to 1 to select PWM mode, pin TIOCA₃ becomes a PWM output pin. The output goes to 1 at compare match with GRA3, and to 0 at compare match with GRB3.

If complementary PWM mode or reset-synchronized PWM mode is selected by bits CMD1 and CMD0 in TFCR, the CMD1 and CMD0 setting takes precedence and the PWM3 setting is ignored.

Bit 2—PWM Mode 2 (PWM2): Selects whether channel 2 operates normally or in PWM mode.

Bit 2: PWM2	Description	
0	Channel 2 operates normally	(Initial value)
1	Channel 2 operates in PWM mode	

When bit PWM2 is set to 1 to select PWM mode, pin TIOCA₂ becomes a PWM output pin. The output goes to 1 at compare match with GRA2, and to 0 at compare match with GRB2.

Bit 1—PWM Mode 1 (PWM1): Selects whether channel 1 operates normally or in PWM mode.

Bit 1: PWM1	Description	
0	Channel 1 operates normally	(Initial value)
1	Channel 1 operates in PWM mode	

When bit PWM1 is set to 1 to select PWM mode, pin TIOCA₁ becomes a PWM output pin. The output goes to 1 at compare match with GRA1, and to 0 at compare match with GRB1.

Bit 0—PWM Mode 0 (PWM0): Selects whether channel 0 operates normally or in PWM mode.

Bit 0: PWM0	Description	
0	Channel 0 operates normally	(Initial value)
1	Channel 0 operates in PWM mode	

When bit PWM0 is set to 1 to select PWM mode, pin TIOCA₀ becomes a PWM output pin. The output goes to 1 at compare match with GRA0, and to 0 at compare match with GRB0.

10.2.4 Timer Function Control Register (TFCR)

TFCR is an 8-bit readable/writable register that selects complementary PWM mode, reset-synchronized PWM mode, and buffering for channels 3 and 4.

Bit	7	6	5	4	3	2	1	0
	—	—	CMD1	CMD0	BFB4	BFA4	BFB3	BFA3
Initial value	1	1	0	0	0	0	0	0
Read/Write	—	—	R/W	R/W	R/W	R/W	R/W	R/W

Reserved bits

Combination mode 1/0
These bits select complementary PWM mode or reset-synchronized PWM mode for channels 3 and 4

Buffer mode B4 and A4
These bits select buffering of general registers (GRB4 and GRA4) by buffer registers (BRB4 and BRA4) in channel 4

Buffer mode B3 and A3
These bits select buffering of general registers (GRB3 and GRA3) by buffer registers (BRB3 and BRA3) in channel 3

TFCR is initialized to H'C0 by a reset and in standby mode.

Bits 7 and 6—Reserved: Read-only bits, always read as 1.

Bits 5 and 4—Combination Mode 1 and 0 (CMD1, CMD0): These bits select whether channels 3 and 4 operate in normal mode, complementary PWM mode, or reset-synchronized PWM mode.

Bit 5: CMD1	Bit 4: CMD0	Description
0	0	Channels 3 and 4 operate normally (Initial value)
	1	
1	0	Channels 3 and 4 operate together in complementary PWM mode
	1	Channels 3 and 4 operate together in reset-synchronized PWM mode

Before selecting reset-synchronized PWM mode or complementary PWM mode, halt the timer counter or counters that will be used in these modes.

When these bits select complementary PWM mode or reset-synchronized PWM mode, they take precedence over the setting of the PWM mode bits (PWM4 and PWM3) in TMDR. Settings of complementary PWM mode or reset-synchronized PWM mode and settings of timer sync bits SYNC4 and SYNC3 in TSNC are valid simultaneously, however, when complementary PWM mode is selected, channels 3 and 4 must not be synchronized (do not set bits SYNC3 and SYNC4 both to 1 in TSNC).

Bit 3—Buffer Mode B4 (BFB4): Selects whether GRB4 operates normally in channel 4, or whether GRB4 is buffered by BRB4.

Bit 3: BFB4	Description	
0	GRB4 operates normally	(Initial value)
1	GRB4 is buffered by BRB4	

Bit 2—Buffer Mode A4 (BFA4): Selects whether GRA4 operates normally in channel 4, or whether GRA4 is buffered by BRA4.

Bit 2: BFA4	Description	
0	GRA4 operates normally	(Initial value)
1	GRA4 is buffered by BRA4	

Bit 1—Buffer Mode B3 (BFB3): Selects whether GRB3 operates normally in channel 3, or whether GRB3 is buffered by BRB3.

Bit 1: BFB3	Description	
0	GRB3 operates normally	(Initial value)
1	GRB3 is buffered by BRB3	

Bit 0—Buffer Mode A3 (BFA3): Selects whether GRA3 operates normally in channel 3, or whether GRA3 is buffered by BRA3.

Bit 0: BFA3	Description	
0	GRA3 operates normally	(Initial value)
1	GRA3 is buffered by BRA3	

10.2.5 Timer Output Master Enable Register (TOER)

TOER is an 8-bit readable/writable register that enables or disables output settings for channels 3 and 4.

Bit	7	6	5	4	3	2	1	0
	—	—	EXB4	EXA4	EB3	EB4	EA4	EA3
Initial value	1	1	1	1	1	1	1	1
Read/Write	—	—	R/W	R/W	R/W	R/W	R/W	R/W

Reserved bits

Master enable TOCXA4, TOCXB4
These bits enable or disable output settings for pins TOCXA₄ and TOCXB₄

Master enable TIOCA3, TIOCB3 , TIOCA4, TIOCB4
These bits enable or disable output settings for pins TIOCA₃, TIOCB₃ , TIOCA₄, and TIOCB₄

TOER is initialized to H'FF by a reset and in standby mode.

Bits 7 and 6—Reserved: Read-only bits, always read as 1.

Bit 5—Master Enable TOCXB4 (EXB4): Enables or disables ITU output at pin TOCXB₄.

Bit 5: EXB4	Description
0	TOCXB ₄ output is disabled regardless of TFCR settings (TOCXB ₄ operates as a generic input/output pin). If XTGD = 0, EXB4 is cleared to 0 when input capture A occurs in channel 1.
1	TOCXB ₄ is enabled for output according to TFCR settings (Initial value)

Bit 4—Master Enable TOCXA4 (EXA4): Enables or disables ITU output at pin TOCXA₄.

Bit 4: EXA4	Description
0	TOCXA ₄ output is disabled regardless of TFCR settings (TOCXA ₄ operates as a generic input/output pin). If XTGD = 0, EXA4 is cleared to 0 when input capture A occurs in channel 1.
1	TOCXA ₄ is enabled for output according to TFCR settings (Initial value)

Bit 3—Master Enable TIOCB3 (EB3): Enables or disables ITU output at pin TIOCB₃.

Bit 3: EB3	Description
0	TIOCB ₃ output is disabled regardless of TIOR3 and TFCR settings (TIOCB ₃ operates as a generic input/output pin). If XTGD = 0, EB3 is cleared to 0 when input capture A occurs in channel 1.
1	TIOCB ₃ is enabled for output according to TIOR3 and TFCR settings (Initial value)

Bit 2—Master Enable TIOCB4 (EB4): Enables or disables ITU output at pin TIOCB₄.

Bit 2: EB4	Description
0	TIOCB ₄ output is disabled regardless of TIOR4 and TFCR settings (TIOCB ₄ operates as a generic input/output pin). If XTGD = 0, EB4 is cleared to 0 when input capture A occurs in channel 1.
1	TIOCB ₄ is enabled for output according to TIOR4 and TFCR settings (Initial value)

Bit 1—Master Enable TIOCA4 (EA4): Enables or disables ITU output at pin TIOCA₄.

Bit 1: EA4	Description
0	TIOCA ₄ output is disabled regardless of TIOR4, TMDR, and TFCR settings (TIOCA ₄ operates as a generic input/output pin). If XTGD = 0, EA4 is cleared to 0 when input capture A occurs in channel 1.
1	TIOCA ₄ is enabled for output according to TIOR4, TMDR, and TFCR settings (Initial value)

Bit 0—Master Enable TIOCA3 (EA3): Enables or disables ITU output at pin TIOCA₃.

Bit 0: EA3	Description
0	TIOCA ₃ output is disabled regardless of TIOR3, TMDR, and TFCR settings (TIOCA ₃ operates as a generic input/output pin). If XTGD = 0, EA3 is cleared to 0 when input capture A occurs in channel 1.
1	TIOCA ₃ is enabled for output according to TIOR3, TMDR, and TFCR settings (Initial value)

10.2.6 Timer Output Control Register (TOCR)

TOCR is an 8-bit readable/writable register that selects externally triggered disabling of output in complementary PWM mode and reset-synchronized PWM mode, and inverts the output levels.

Bit	7	6	5	4	3	2	1	0
	—	—	—	XTGD	—	—	OLS4	OLS3
Initial value	1	1	1	1	1	1	1	1
Read/Write	—	—	—	R/W	—	—	R/W	R/W

Reserved bits (bits 7, 6, 5)
External trigger disable (bit 4)
Reserved bits (bits 3, 2)
Output level select 3, 4 (bits 1, 0)
 These bits select output levels in complementary PWM mode and reset-synchronized PWM mode

External trigger disable
 Selects externally triggered disabling of output in complementary PWM mode and reset-synchronized PWM mode

The settings of the XTGD, OLS4, and OLS3 bits are valid only in complementary PWM mode and reset-synchronized PWM mode. These settings do not affect other modes.

TOCR is initialized to H'FF by a reset and in standby mode.

Bits 7 to 5—Reserved: Read-only bits, always read as 1.

Bit 4—External Trigger Disable (XTGD): Selects externally triggered disabling of ITU output in complementary PWM mode and reset-synchronized PWM mode.

Bit 4: XTGD	Description
0	Input capture A in channel 1 is used as an external trigger signal in complementary PWM mode and reset-synchronized PWM mode. When an external trigger occurs, bits 5 to 0 in TOER are cleared to 0, disabling ITU output.
1	External triggering is disabled (Initial value)

Bits 3 and 2—Reserved: Read-only bits, always read as 1.

Bit 1—Output Level Select 4 (OLS4): Selects output levels in complementary PWM mode and reset-synchronized PWM mode.

Bit 1: OLS4	Description
0	TIOCA ₃ , TIOCA ₄ , and TIOCB ₄ outputs are inverted
1	TIOCA ₃ , TIOCA ₄ , and TIOCB ₄ outputs are not inverted (Initial value)

Bit 0—Output Level Select 3 (OLS3): Selects output levels in complementary PWM mode and reset-synchronized PWM mode.

Bit 0: OLS3	Description
0	TIOCB ₃ , TOCXA ₄ , and TOCXB ₄ outputs are inverted
1	TIOCB ₃ , TOCXA ₄ , and TOCXB ₄ outputs are not inverted (Initial value)

10.2.7 Timer Counters (TCNT)

TCNT is a 16-bit counter. The ITU has five TCNTs, one for each channel.

Channel	Abbreviation	Function
0	TCNT0	Up-counter
1	TCNT1	
2	TCNT2	Phase counting mode: up/down-counter Other modes: up-counter
3	TCNT3	Complementary PWM mode: up/down-counter
4	TCNT4	Other modes: up-counter

Bit	15	14	13	12	11	10	9	8	7	6	5	4	3	2	1	0
Initial value	0	0	0	0	0	0	0	0	0	0	0	0	0	0	0	0
Read/Write	R/W	R/W	R/W	R/W	R/W	R/W	R/W	R/W	R/W	R/W	R/W	R/W	R/W	R/W	R/W	R/W

Each TCNT is a 16-bit readable/writable register that counts pulse inputs from a clock source. The clock source is selected by bits TPSC2 to TPSC0 in TCR.

TCNT0 and TCNT1 are up-counters. TCNT2 is an up/down-counter in phase counting mode and an up-counter in other modes. TCNT3 and TCNT4 are up/down-counters in complementary PWM mode and up-counters in other modes.

TCNT can be cleared to H'0000 by compare match with GRA or GRB or by input capture to GRA or GRB (counter clearing function) in the same channel.

When TCNT overflows (changes from H'FFFF to H'0000), the OVF flag is set to 1 in TSR of the corresponding channel.

When TCNT underflows (changes from H'0000 to H'FFFF), the OVF flag is set to 1 in TSR of the corresponding channel.

The TCNTs are linked to the CPU by an internal 16-bit bus and can be written or read by either word access or byte access.

Each TCNT is initialized to H'0000 by a reset and in standby mode.

10.2.8 General Registers A, B (GRA, GRB)

The general registers are 16-bit registers. The ITU has 10 general registers, two in each channel.

Channel	Abbreviation	Function
0	GRA0, GRB0	Output compare/input capture register
1	GRA1, GRB1	
2	GRA2, GRB2	
3	GRA3, GRB3	Output compare/input capture register; can be buffered by
4	GRA4, GRB4	buffer registers BRA and BRB

Bit	15	14	13	12	11	10	9	8	7	6	5	4	3	2	1	0
Initial value	1	1	1	1	1	1	1	1	1	1	1	1	1	1	1	1
Read/Write	R/W	R/W	R/W	R/W	R/W	R/W	R/W	R/W	R/W	R/W	R/W	R/W	R/W	R/W	R/W	R/W

A general register is a 16-bit readable/writable register that can function as either an output compare register or an input capture register. The function is selected by settings in TIOR.

When a general register is used as an output compare register, its value is constantly compared with the TCNT value. When the two values match (compare match), the IMFA or IMFB flag is set to 1 in TSR. Compare match output can be selected in TIOR.

When a general register is used as an input capture register, rising edges, falling edges, or both edges of an external input capture signal are detected and the current TCNT value is stored in the

general register. The corresponding IMFA or IMFB flag in TSR is set to 1 at the same time. The valid edge or edges of the input capture signal are selected in TIOR.

TIOR settings are ignored in PWM mode, complementary PWM mode, and reset-synchronized PWM mode.

General registers are linked to the CPU by an internal 16-bit bus and can be written or read by either word access or byte access.

General registers are initialized to the output compare function (with no output signal) by a reset and in standby mode. The initial value is H'FFFF.

10.2.9 Buffer Registers A, B (BRA, BRB)

The buffer registers are 16-bit registers. The ITU has four buffer registers, two each in channels 3 and 4.

Channel	Abbreviation	Function
3	BRA3, BRB3	Used for buffering
4	BRA4, BRB4	<ul style="list-style-type: none"> When the corresponding GRA or GRB functions as an output compare register, BRA or BRB can function as an output compare buffer register: the BRA or BRB value is automatically transferred to GRA or GRB at compare match When the corresponding GRA or GRB functions as an input capture register, BRA or BRB can function as an input capture buffer register: the GRA or GRB value is automatically transferred to BRA or BRB at input capture

Bit	15	14	13	12	11	10	9	8	7	6	5	4	3	2	1	0
Initial value	1	1	1	1	1	1	1	1	1	1	1	1	1	1	1	1
Read/Write	R/W	R/W	R/W	R/W	R/W	R/W	R/W	R/W	R/W	R/W	R/W	R/W	R/W	R/W	R/W	R/W

A buffer register is a 16-bit readable/writable register that is used when buffering is selected. Buffering can be selected independently by bits BFB4, BFA4, BFB3, and BFA3 in TFCR.

The buffer register and general register operate as a pair. When the general register functions as an output compare register, the buffer register functions as an output compare buffer register. When

the general register functions as an input capture register, the buffer register functions as an input capture buffer register.

The buffer registers are linked to the CPU by an internal 16-bit bus and can be written or read by either word or byte access.

Buffer registers are initialized to H'FFFF by a reset and in standby mode.

10.2.10 Timer Control Registers (TCR)

TCR is an 8-bit register. The ITU has five TCRs, one in each channel.

Channel	Abbreviation	Function
0	TCR0	TCR controls the timer counter. The TCRs in all channels are functionally identical. When phase counting mode is selected in channel 2, the settings of bits CKEG1 and CKEG0 and TPSC2 to TPSC0 in TCR2 are ignored.
1	TCR1	
2	TCR2	
3	TCR3	
4	TCR4	

Bit	7	6	5	4	3	2	1	0
	—	CCLR1	CCLR0	CKEG1	CKEG0	TPSC2	TPSC1	TPSC0
Initial value	1	0	0	0	0	0	0	0
Read/Write	—	R/W	R/W	R/W	R/W	R/W	R/W	R/W

Reserved bit
Counter clear 1, 0
 These bits select the counter clear source

Clock edge 1, 0
 These bits select external clock edges

Timer prescaler 2 to 0
 These bits select the counter clock

Each TCR is an 8-bit readable/writable register that selects the timer counter clock source, selects the edge or edges of external clock sources, and selects how the counter is cleared.

TCR is initialized to H'80 by a reset and in standby mode.

Bit 7—Reserved: Read-only bit, always read as 1.

Bits 6 and 5—Counter Clear 1 and 0 (CCLR1, CCLR0): These bits select how TCNT is cleared.

Bit 6: CCLR1	Bit 5: CCLR0	Description
0	0	TCNT is not cleared (Initial value)
	1	TCNT is cleared by GRA compare match or input capture ^{*1}
1	0	TCNT is cleared by GRB compare match or input capture ^{*1}
	1	Synchronous clear: TCNT is cleared in synchronization with other synchronized timers ^{*2}

Notes: 1. TCNT is cleared by compare match when the general register functions as an output compare register, and by input capture when the general register functions as an input capture register.

2. Selected in TSNC.

Bits 4 and 3—Clock Edge 1 and 0 (CKEG1, CKEG0): These bits select external clock input edges when an external clock source is used.

Bit 4: CKEG1	Bit 3: CKEG0	Description
0	0	Count rising edges (Initial value)
	1	Count falling edges
1	—	Count both edges

When channel 2 is set to phase counting mode, bits CKEG1 and CKEG0 in TCR2 are ignored. Phase counting takes precedence.

Bits 2 to 0—Timer Prescaler 2 to 0 (TPSC2 to TPSC0): These bits select the counter clock source.

Bit 2: TPSC2	Bit 1: TPSC1	Bit 0: TPSC0	Description
0	0	0	Internal clock: ϕ (Initial value)
		1	Internal clock: $\phi/2$
	1	0	Internal clock: $\phi/4$
		1	Internal clock: $\phi/8$
1	0	0	External clock A: TCLKA input
		1	External clock B: TCLKB input
	1	0	External clock C: TCLKC input
		1	External clock D: TCLKD input

When bit TPSC2 is cleared to 0 an internal clock source is selected, and the timer counts only falling edges. When bit TPSC2 is set to 1 an external clock source is selected, and the timer counts the edge or edges selected by bits CKEG1 and CKEG0.

When channel 2 is set to phase counting mode ($MDF = 1$ in TMDR), the settings of bits TPSC2 to TPSC0 in TCR2 are ignored. Phase counting takes precedence.

10.2.11 Timer I/O Control Register (TIOR)

TIOR is an 8-bit register. The ITU has five TIORs, one in each channel.

Channel	Abbreviation	Function
0	TIOR0	TIOR controls the general registers. Some functions differ in PWM mode. TIOR3 and TIOR4 settings are ignored when complementary PWM mode or reset-synchronized PWM mode is selected in channels 3 and 4.
1	TIOR1	
2	TIOR2	
3	TIOR3	
4	TIOR4	

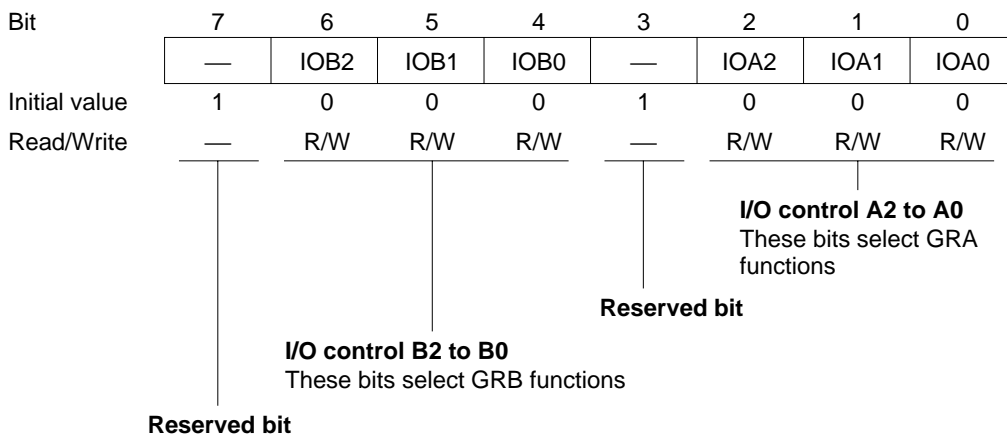

Each TIOR is an 8-bit readable/writable register that selects the output compare or input capture function for GRA and GRB, and specifies the functions of the TIOCA and TIOCB pins. If the output compare function is selected, TIOR also selects the type of output. If input capture is selected, TIOR also selects the edge or edges of the input capture signal.

TIOR is initialized to H'88 by a reset and in standby mode.

Bit 7—Reserved: Read-only bit, always read as 1.

Bits 6 to 4—I/O Control B2 to B0 (IOB2 to IOB0): These bits select the GRB function.

Bit 6: IOB2	Bit 5: IOB1	Bit 4: IOB0	Description	
0	0	0	GRB is an output compare register	No output at compare match (Initial value)
		1		0 output at GRB compare match ^{*1}
	1	0		1 output at GRB compare match ^{*1}
		1		Output toggles at GRB compare match (1 output in channel 2) ^{*1 *2}
1	0	0	GRB is an input capture register	GRB captures rising edge of input
		1		GRB captures falling edge of input
	1	0		GRB captures both edges of input
		1		

- Notes: 1. After a reset, the output is 0 until the first compare match.
2. Channel 2 output cannot be toggled by compare match. This setting selects 1 output instead.

Bit 3—Reserved: Read-only bit, always read as 1.

Bits 2 to 0—I/O Control A2 to A0 (IOA2 to IOA0): These bits select the GRA function.

Bit 2: IOA2	Bit 1: IOA1	Bit 0: IOA0	Description	
0	0	0	GRA is an output compare register	No output at compare match (Initial value)
		1		0 output at GRA compare match ^{*1}
	1	0		1 output at GRA compare match ^{*1}
		1		Output toggles at GRA compare match (1 output in channel 2) ^{*1 *2}
1	0	0	GRA is an input capture register	GRA captures rising edge of input
		1		GRA captures falling edge of input
	1	0		GRA captures both edges of input
		1		

- Notes: 1. After a reset, the output is 0 until the first compare match.
2. Channel 2 output cannot be toggled by compare match. This setting selects 1 output instead.

10.2.12 Timer Status Register (TSR)

TSR is an 8-bit register. The ITU has five TSRs, one in each channel.

Channel	Abbreviation	Function
0	TSR0	Indicates input capture, compare match, and overflow status
1	TSR1	
2	TSR2	
3	TSR3	
4	TSR4	

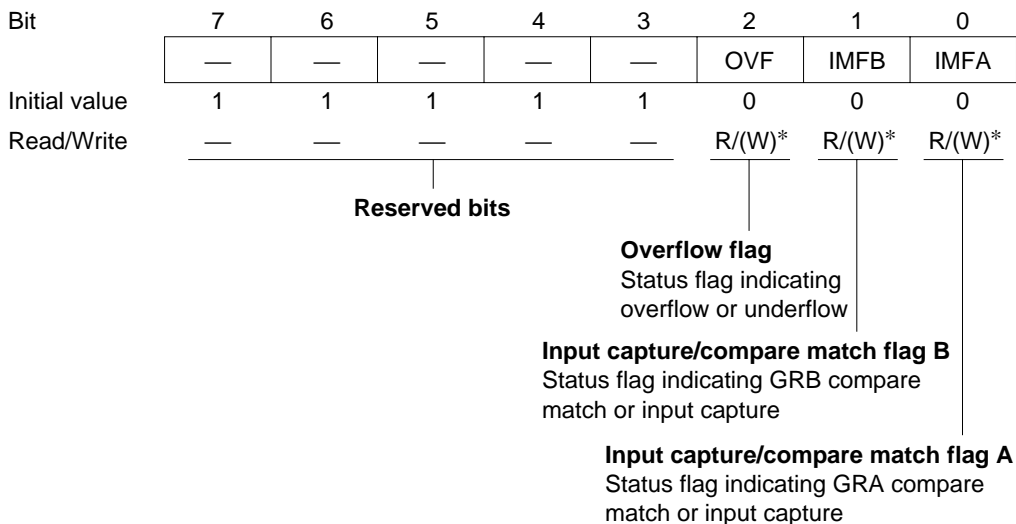

Note: * Only 0 can be written, to clear the flag.

Each TSR is an 8-bit readable/writable register containing flags that indicate TCNT overflow or underflow and GRA or GRB compare match or input capture. These flags are interrupt sources and generate CPU interrupts if enabled by corresponding bits in TIER.

TSR is initialized to H'F8 by a reset and in standby mode.

Bits 7 to 3—Reserved: Read-only bits, always read as 1.

Bit 2—Overflow Flag (OVF): This status flag indicates TCNT overflow or underflow.

Bit 2: OVF	Description
0	[Clearing condition] (Initial value) Read OVF when OVF = 1, then write 0 in OVF
1	[Setting condition] TCNT overflowed from H'FFFF to H'0000, or underflowed from H'0000 to H'FFFF*

Note: * TCNT underflow occurs when TCNT operates as an up/down-counter. Underflow occurs only under the following conditions:

- (1) Channel 2 operates in phase counting mode (MDF = 1 in TMDR)
- (2) Channels 3 and 4 operate in complementary PWM mode (CMD1 = 1 and CMD0 = 0 in TFCR)

Bit 1—Input Capture/Compare Match Flag B (IMFB): This status flag indicates GRB compare match or input capture events.

Bit 1: IMFB	Description
0	[Clearing condition] (Initial value) Read IMFB when IMFB = 1, then write 0 in IMFB
1	[Setting conditions] TCNT = GRB when GRB functions as an output compare register. TCNT value is transferred to GRB by an input capture signal, when GRB functions as an input capture register.

Bit 0—Input Capture/Compare Match Flag A (IMFA): This status flag indicates GRA compare match or input capture events.

Bit 0: IMFA	Description
0	[Clearing conditions] (Initial value) Read IMFA when IMFA = 1, then write 0 in IMFA. DMAC activated by IMIA interrupt (channels 0 to 3 only).
1	[Setting conditions] TCNT = GRA when GRA functions as an output compare register. TCNT value is transferred to GRA by an input capture signal, when GRA functions as an input capture register.

10.2.13 Timer Interrupt Enable Register (TIER)

TIER is an 8-bit register. The ITU has five TIERS, one in each channel.

Channel	Abbreviation	Function
0	TIER0	Enables or disables interrupt requests.
1	TIER1	
2	TIER2	
3	TIER3	
4	TIER4	

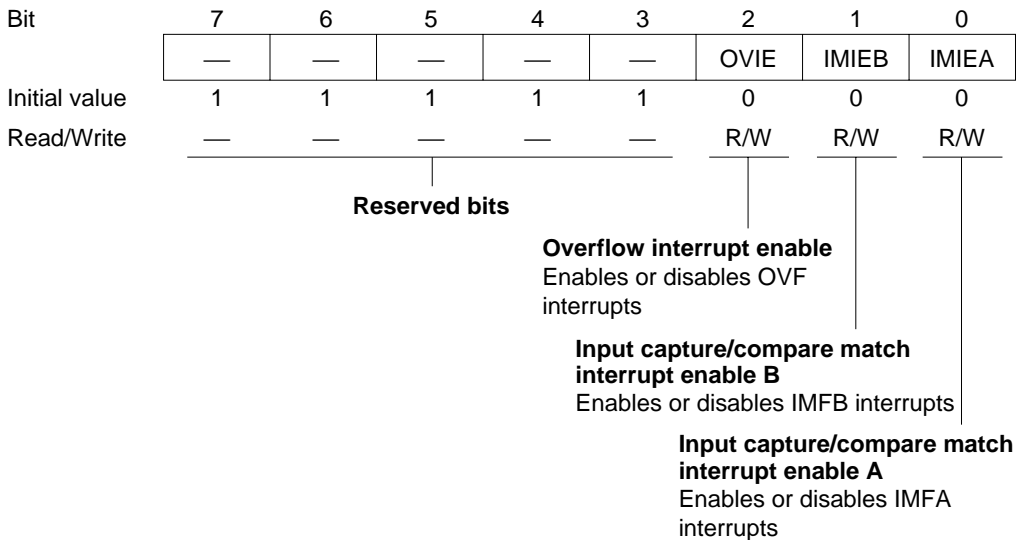

Each TIER is an 8-bit readable/writable register that enables and disables overflow interrupt requests and general register compare match and input capture interrupt requests.

TIER is initialized to H'F8 by a reset and in standby mode.

Bits 7 to 3—Reserved: Read-only bits, always read as 1.

Bit 2—Overflow Interrupt Enable (OVIE): Enables or disables the interrupt requested by the OVF flag in TSR when OVF is set to 1.

Bit 2: OVIE	Description
0	OVI interrupt requested by OVF is disabled (Initial value)
1	OVI interrupt requested by OVF is enabled

Bit 1—Input Capture/Compare Match Interrupt Enable B (IMIEB): Enables or disables the interrupt requested by the IMFB flag in TSR when IMFB is set to 1.

Bit 1: IMIEB	Description
0	IMIB interrupt requested by IMFB is disabled (Initial value)
1	IMIB interrupt requested by IMFB is enabled

Bit 0—Input Capture/Compare Match Interrupt Enable A (IMIEA): Enables or disables the interrupt requested by the IMFA flag in TSR when IMFA is set to 1.

Bit 0: IMIEA	Description
0	IMIA interrupt requested by IMFA is disabled (Initial value)
1	IMIA interrupt requested by IMFA is enabled

10.3 CPU Interface

10.3.1 16-Bit Accessible Registers

The timer counters (TCNTs), general registers A and B (GRAs and GRBs), and buffer registers A and B (BRAs and BRBs) are 16-bit registers, and are linked to the CPU by an internal 16-bit data bus. These registers can be written or read a word at a time, or a byte at a time.

Figures 10.6 and 10.7 show examples of word access to a timer counter (TCNT). Figures 10.8 to 10.11 show examples of byte access to TCNTH and TCNTL.

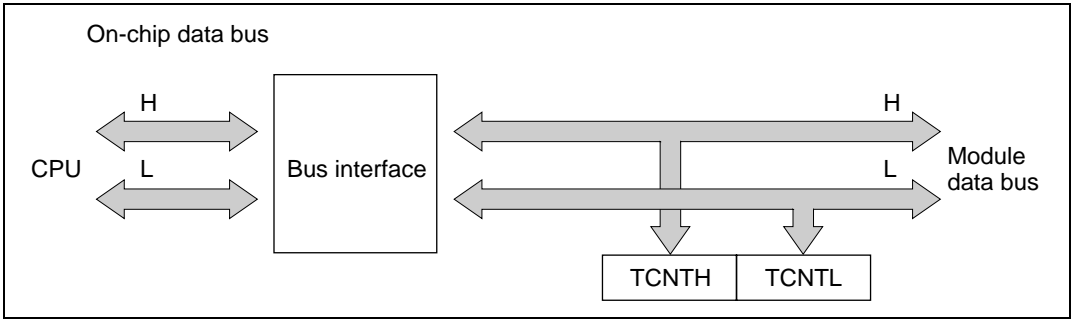

Figure 10.6 Access to Timer Counter (CPU Writes to TCNT, Word)

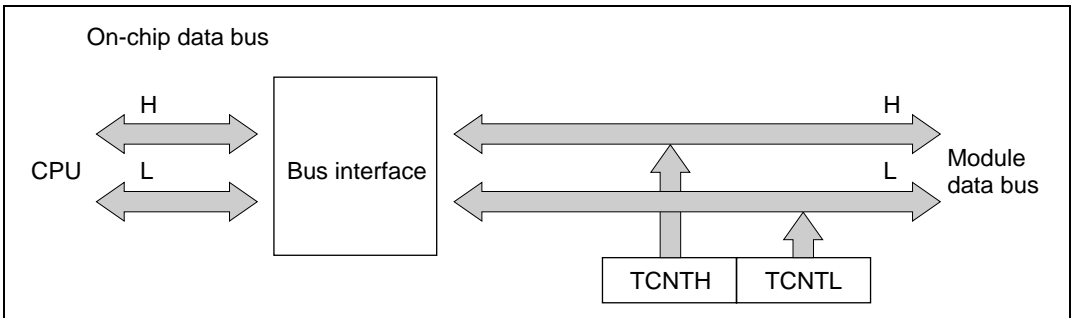

Figure 10.7 Access to Timer Counter (CPU Reads TCNT, Word)

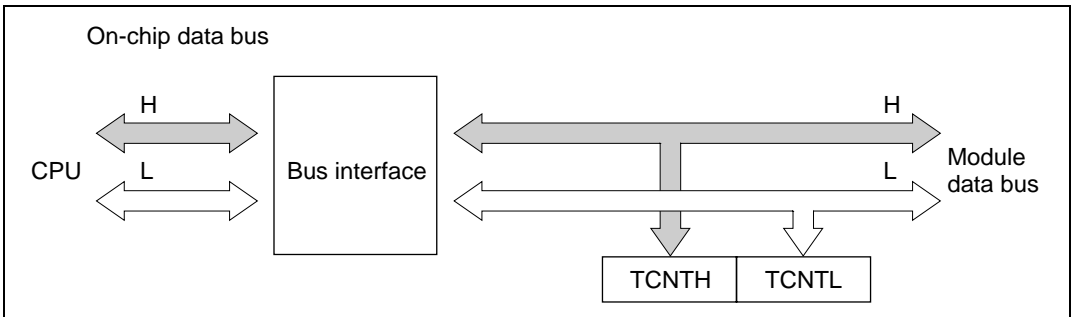

Figure 10.8 Access to Timer Counter (CPU Writes to TCNT, Upper Byte)

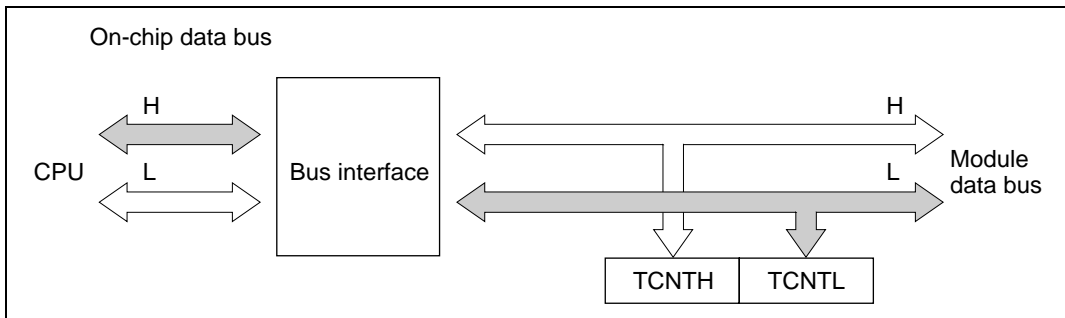

Figure 10.9 Access to Timer Counter (CPU Writes to TCNT, Lower Byte)

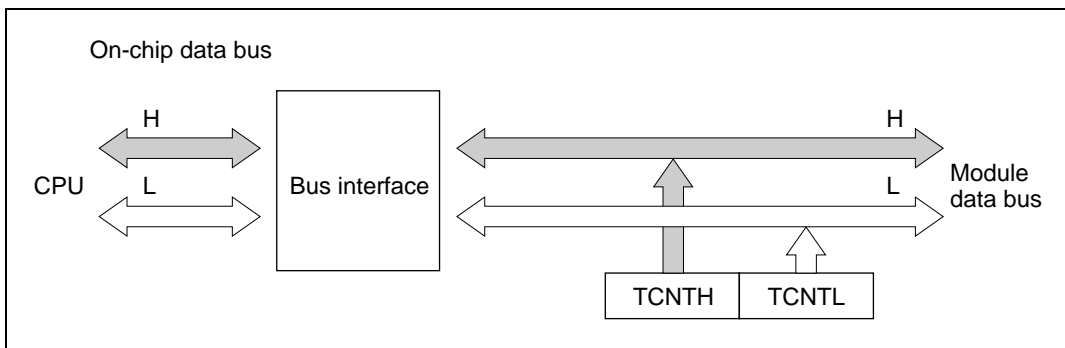

Figure 10.10 Access to Timer Counter (CPU Reads TCNT, Upper Byte)

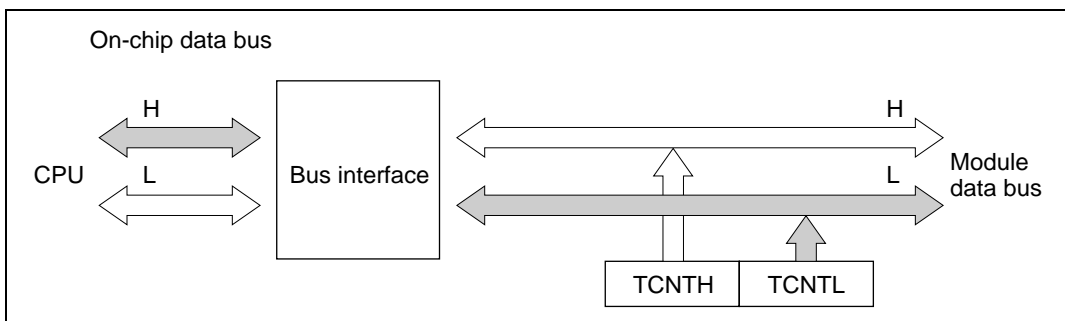

Figure 10.11 Access to Timer Counter (CPU Reads TCNT, Lower Byte)

10.3.2 8-Bit Accessible Registers

The registers other than the timer counters, general registers, and buffer registers are 8-bit registers. These registers are linked to the CPU by an internal 8-bit data bus.

Figures 10.12 and 10.13 show examples of byte read and write access to a TCR.

If a word-size data transfer instruction is executed, two byte transfers are performed.

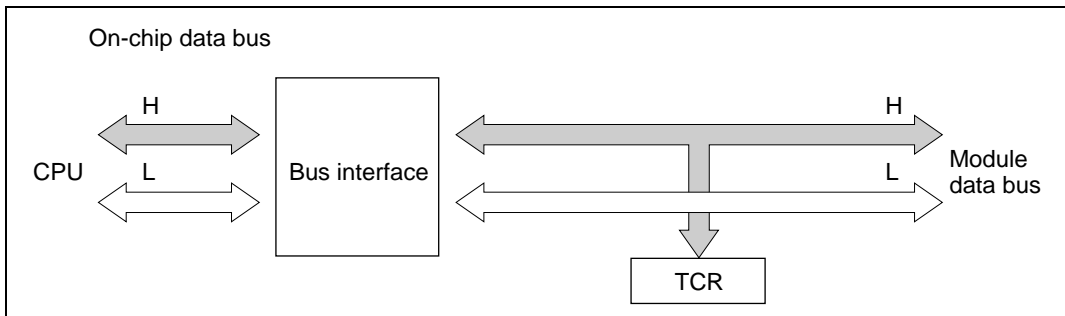

Figure 10.12 Access to Timer Counter (CPU Writes to TCR)

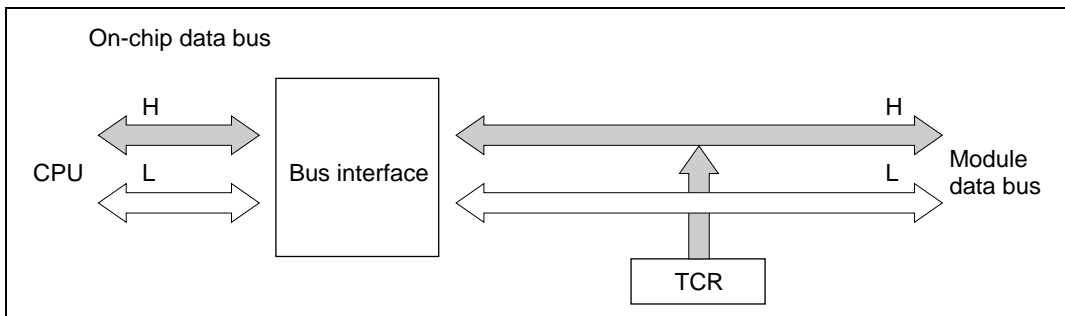

Figure 10.13 Access to Timer Counter (CPU Reads TCR)

10.4 Operation

10.4.1 Overview

A summary of operations in the various modes is given below.

Normal Operation

Each channel has a timer counter and general registers. The timer counter counts up, and can operate as a free-running counter, periodic counter, or external event counter. General registers A and B can be used for input capture or output compare.

Synchronous Operation

The timer counters in designated channels are preset synchronously. Data written to the timer counter in any one of these channels is simultaneously written to the timer counters in the other channels as well. The timer counters can also be cleared synchronously if so designated by the CCLR1 and CCLR0 bits in the TCRs.

PWM Mode

A PWM waveform is output from the TIOCA pin. The output goes to 1 at compare match A and to 0 at compare match B. The duty cycle can be varied from 0% to 100% depending on the settings of GRA and GRB. When a channel is set to PWM mode, its GRA and GRB automatically become output compare registers.

Reset-Synchronized PWM Mode

Channels 3 and 4 are paired for three-phase PWM output with complementary waveforms. (The three phases are related by having a common transition point.) When reset-synchronized PWM mode is selected GRA3, GRB3, GRA4, and GRB4 automatically function as output compare registers, TIOCA₃, TIOCB₃, TIOCA₄, TOCXA₄, TIOCB₄, and TOCXB₄ function as PWM output pins, and TCNT3 operates as an up-counter. TCNT4 operates independently, and is not compared with GRA4 or GRB4.

Complementary PWM Mode

Channels 3 and 4 are paired for three-phase PWM output with non-overlapping complementary waveforms. When complementary PWM mode is selected GRA3, GRB3, GRA4, and GRB4 automatically function as output compare registers, and TIOCA₃, TIOCB₃, TIOCA₄, TOCXA₄, TIOCB₄, and TOCXB₄ function as PWM output pins. TCNT3 and TCNT4 operate as up/down-counters.

Phase Counting Mode

The phase relationship between two clock signals input at TCLKA and TCLKB is detected and TCNT2 counts up or down accordingly. When phase counting mode is selected TCLKA and TCLKB become clock input pins and TCNT2 operates as an up/down-counter.

Buffering

- If the general register is an output compare register
When compare match occurs the buffer register value is transferred to the general register.
- If the general register is an input capture register
When input capture occurs the TCNT value is transferred to the general register, and the previous general register value is transferred to the buffer register.
- Complementary PWM mode
The buffer register value is transferred to the general register when TCNT3 and TCNT4 change counting direction.
- Reset-synchronized PWM mode
The buffer register value is transferred to the general register at GRA3 compare match.

10.4.2 Basic Functions

Counter Operation

When one of bits STR0 to STR4 is set to 1 in the timer start register (TSTR), the timer counter (TCNT) in the corresponding channel starts counting. The counting can be free-running or periodic.

Sample setup procedure for counter: Figure 10.14 shows a sample procedure for setting up a counter.

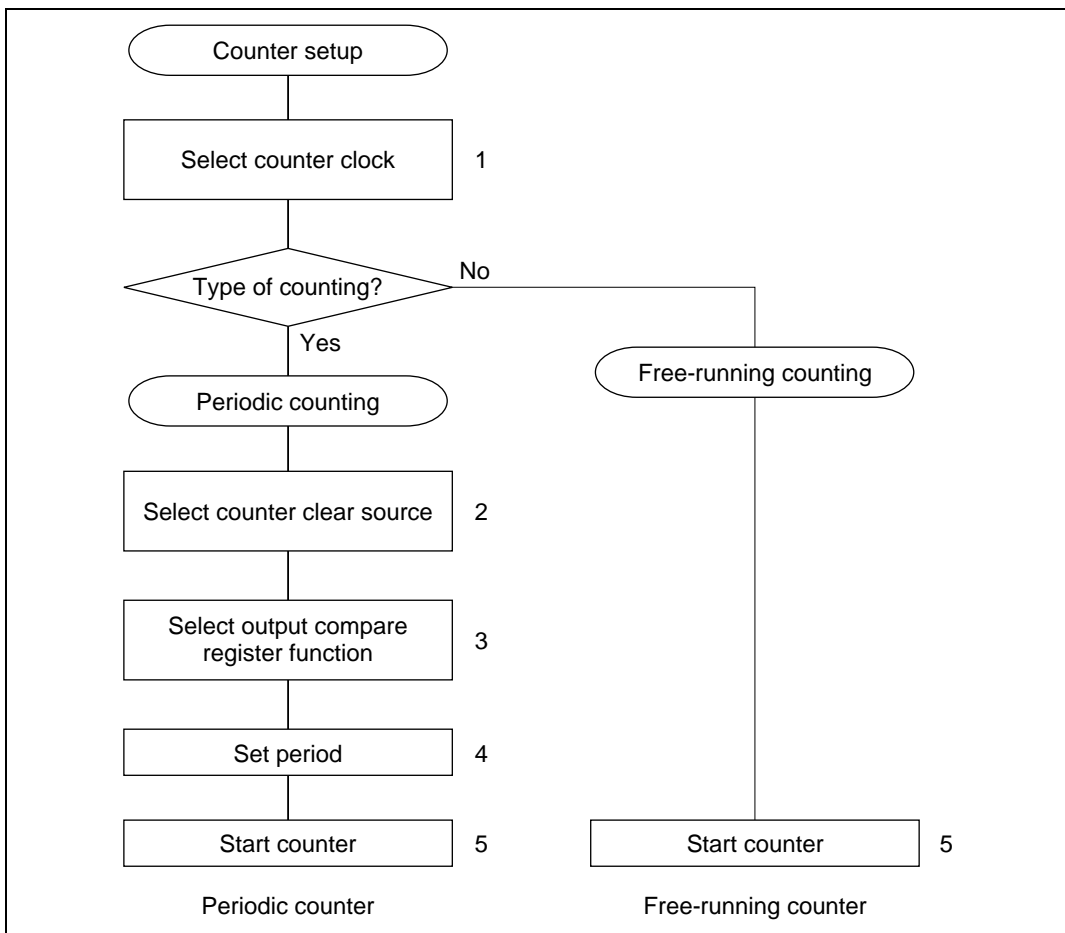

Figure 10.14 Counter Setup Procedure (Example)

1. Set bits TPSC2 to TPSC0 in TCR to select the counter clock source. If an external clock source is selected, set bits CKEG1 and CKEG0 in TCR to select the desired edge(s) of the external clock signal.
2. For periodic counting, set CCLR1 and CCLR0 in TCR to have TCNT cleared at GRA compare match or GRB compare match.
3. Set TIOR to select the output compare function of GRA or GRB, whichever was selected in step 2.
4. Write the count period in GRA or GRB, whichever was selected in step 2.
5. Set the STR bit to 1 in TSTR to start the timer counter.

Free-running and periodic counter operation: A reset leaves the counters (TCNTs) in ITU channels 0 to 4 all set as free-running counters. A free-running counter starts counting up when the corresponding bit in TSTR is set to 1. When the count overflows from H'FFFF to H'0000, the OVF flag is set to 1 in TSR. If the corresponding OVIE bit is set to 1 in TIER, a CPU interrupt is requested. After the overflow, the counter continues counting up from H'0000. Figure 10.15 illustrates free-running counting.

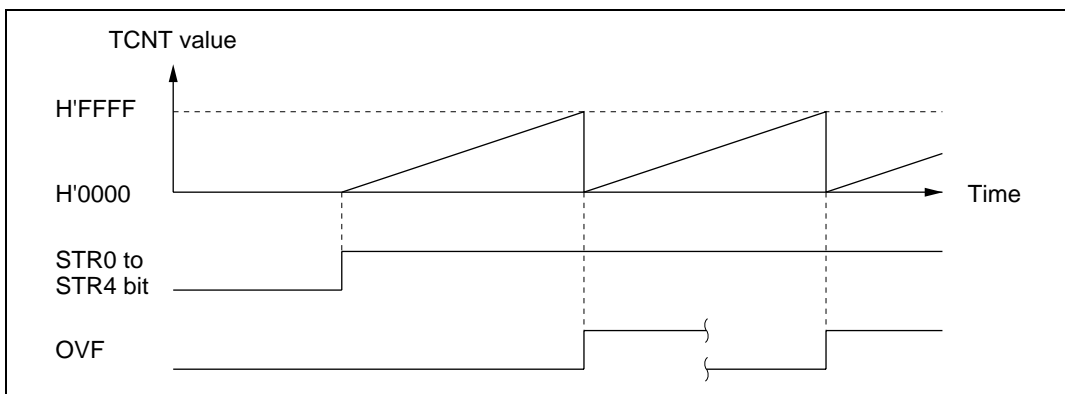

Figure 10.15 Free-Running Counter Operation

When a channel is set to have its counter cleared by compare match, in that channel TCNT operates as a periodic counter. Select the output compare function of GRA or GRB, set bit CCLR1 or CCLR0 in TCR to have the counter cleared by compare match, and set the count period in GRA or GRB. After these settings, the counter starts counting up as a periodic counter when the corresponding bit is set to 1 in TSTR. When the count matches GRA or GRB, the IMFA or IMFB flag is set to 1 in TSR and the counter is cleared to H'0000. If the corresponding IMIEA or IMIEB bit is set to 1 in TIER, a CPU interrupt is requested at this time. After the compare match, TCNT continues counting up from H'0000. Figure 10.16 illustrates periodic counting.

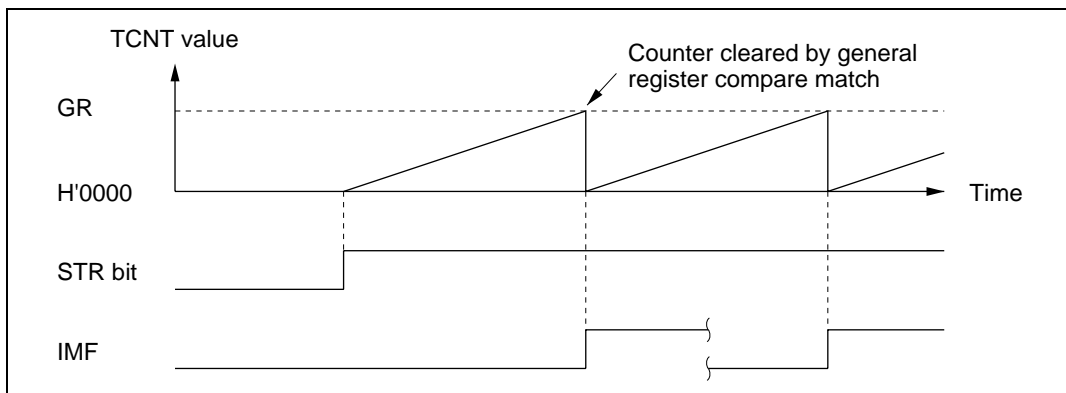

Figure 10.16 Periodic Counter Operation

TCNT count timing:

- Internal clock source

Bits TPSC2 to TPSC0 in TCR select the system clock (ϕ) or one of three internal clock sources obtained by prescaling the system clock ($\phi/2$, $\phi/4$, $\phi/8$).

Figure 10.17 shows the timing.

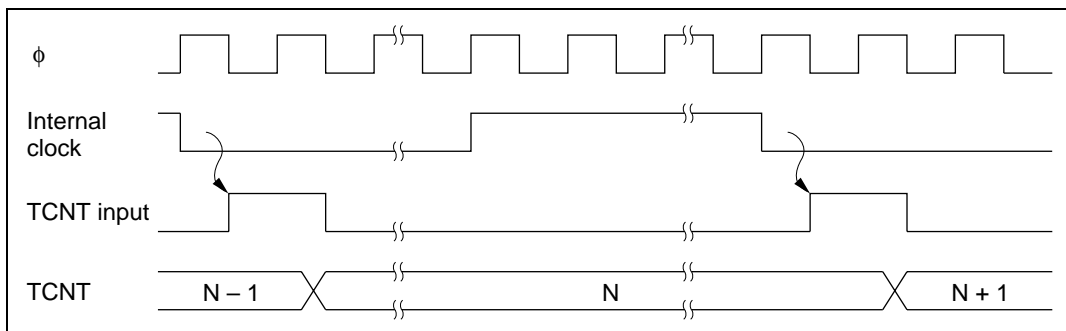

Figure 10.17 Count Timing for Internal Clock Sources

- External clock source

Bits TPSC2 to TPSC0 in TCR select an external clock input pin (TCLKA to TCLKD), and its valid edge or edges are selected by bits CKEG1 and CKEG0. The rising edge, falling edge, or both edges can be selected.

The pulse width of the external clock signal must be at least 1.5 system clocks when a single edge is selected, and at least 2.5 system clocks when both edges are selected. Shorter pulses will not be counted correctly.

Figure 10.18 shows the timing when both edges are detected.

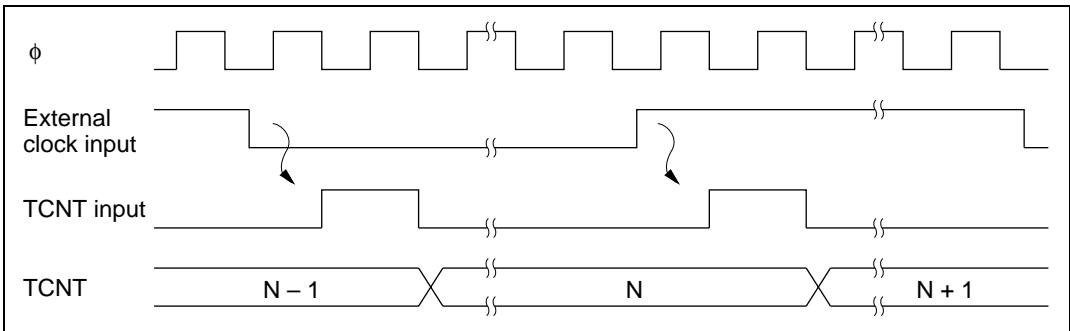

Figure 10.18 Count Timing for External Clock Sources (when Both Edges Are Detected)

Waveform Output by Compare Match

In ITU channels 0, 1, 3, and 4, compare match A or B can cause the output at the TIOCA or TIOCB pin to go to 0, go to 1, or toggle. In channel 2 the output can only go to 0 or go to 1.

Sample setup procedure for waveform output by compare match: Figure 10.19 shows a sample procedure for setting up waveform output by compare match.

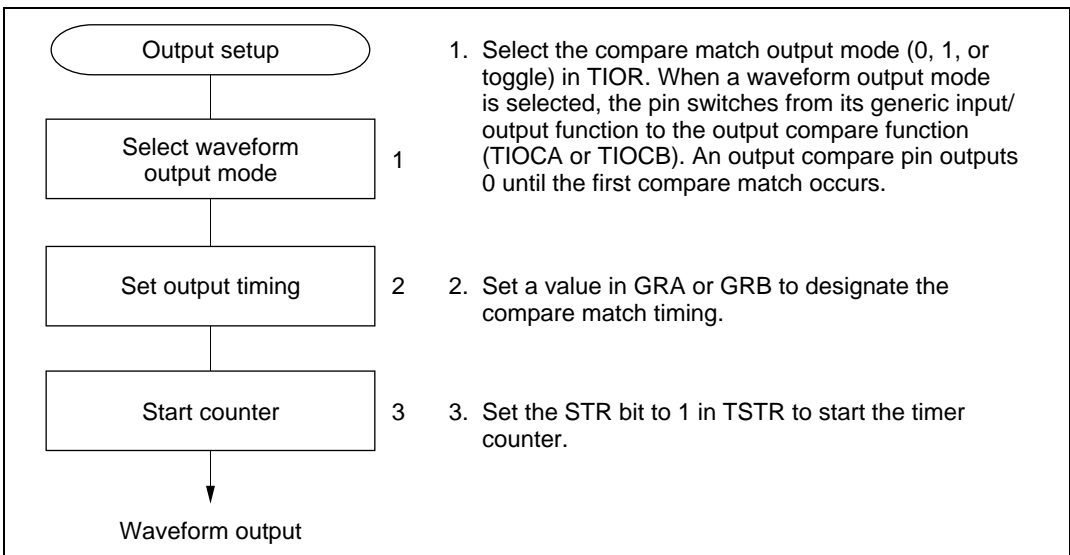

Figure 10.19 Setup Procedure for Waveform Output by Compare Match (Example)

Examples of waveform output: Figure 10.20 shows examples of 0 and 1 output. TCNT operates as a free-running counter, 0 output is selected for compare match A, and 1 output is selected for compare match B. When the pin is already at the selected output level, the pin level does not change.

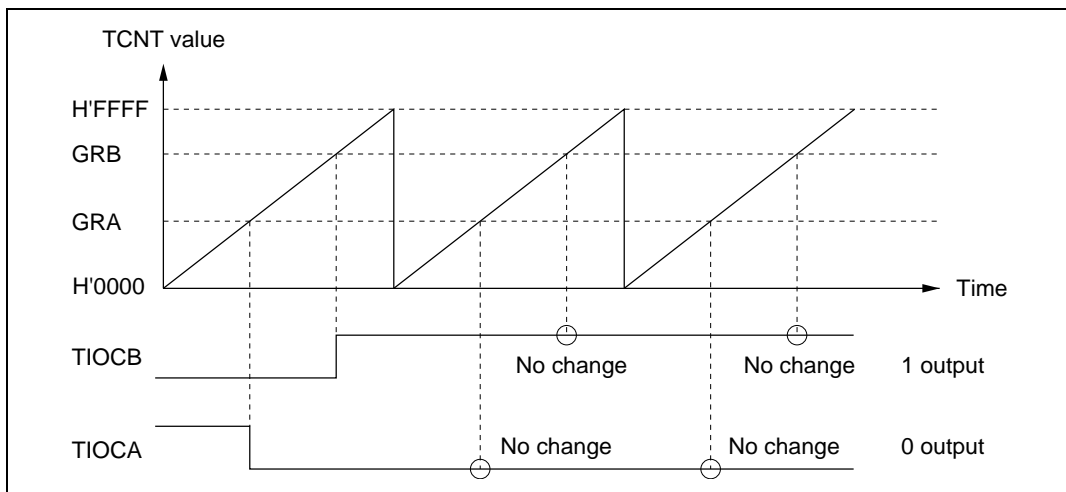

Figure 10.20 0 and 1 Output (Examples)

Figure 10.21 shows examples of toggle output. TCNT operates as a periodic counter, cleared by compare match B. Toggle output is selected for both compare match A and B.

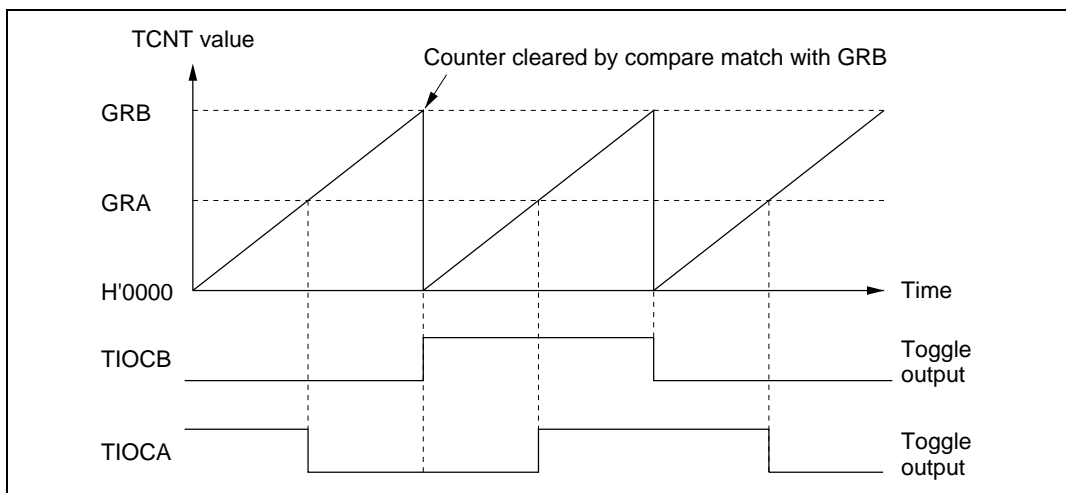

Figure 10.21 Toggle Output (Example)

Output compare timing: The compare match signal is generated in the last state in which TCNT and the general register match (when TCNT changes from the matching value to the next value). When the compare match signal is generated, the output value selected in TIOR is output at the output compare pin (TIOCA or TIOCB). When TCNT matches a general register, the compare match signal is not generated until the next counter clock pulse.

Figure 10.22 shows the output compare timing.

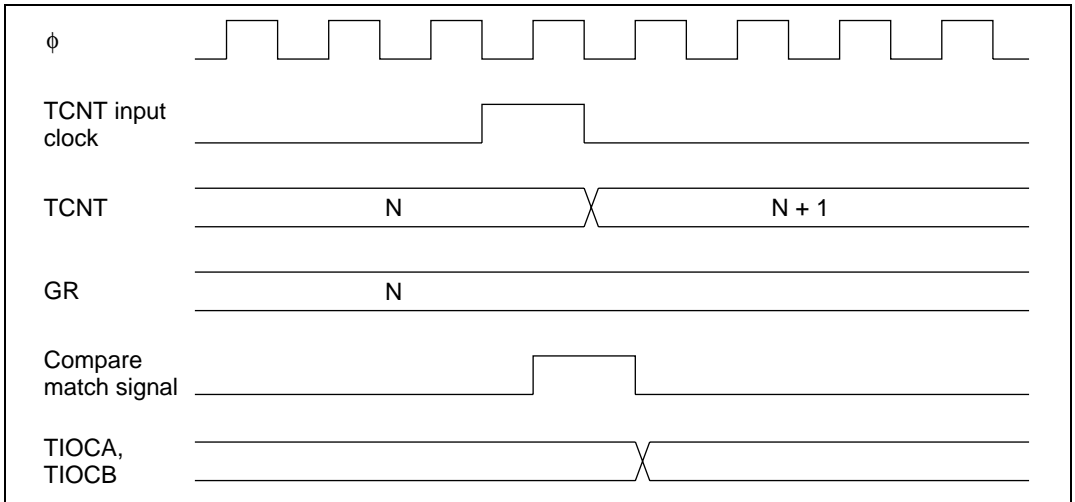

Figure 10.22 Output Compare Timing

Input Capture Function

The TCNT value can be captured into a general register when a transition occurs at an input capture/output compare pin (TIOCA or TIOCB). Capture can take place on the rising edge, falling edge, or both edges. The input capture function can be used to measure pulse width or period.

Sample setup procedure for input capture: Figure 10.23 shows a sample procedure for setting up input capture.

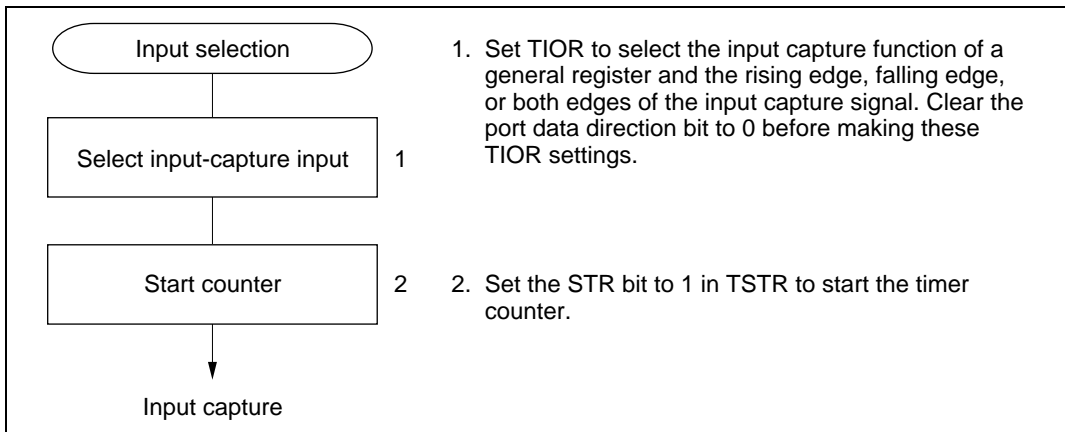

Figure 10.23 Setup Procedure for Input Capture (Example)

Examples of input capture: Figure 10.24 illustrates input capture when the falling edge of TIOCB and both edges of TIOCA are selected as capture edges. TCNT is cleared by input capture into GRB.

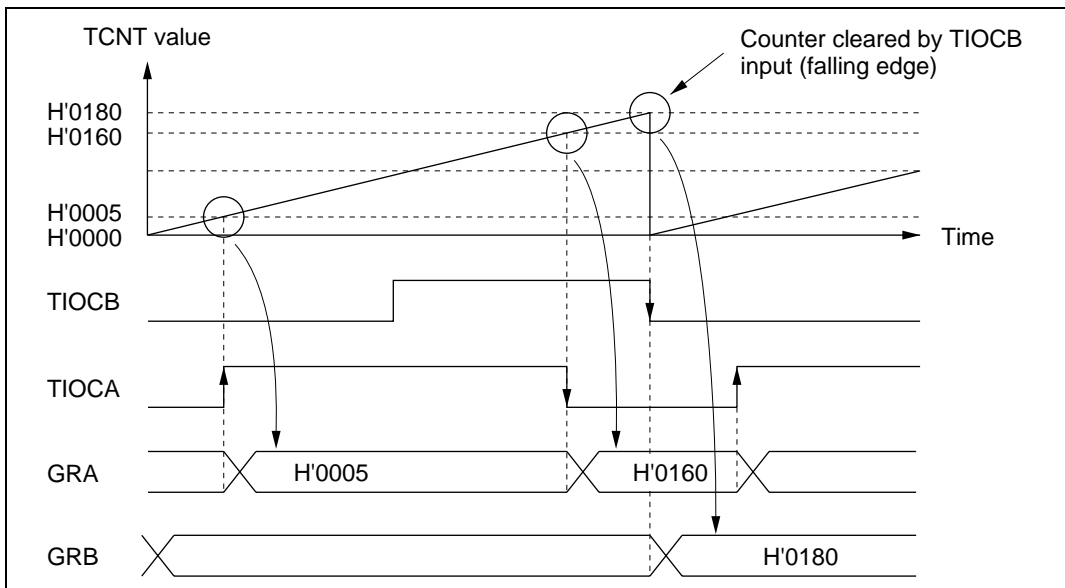

Figure 10.24 Input Capture (Example)

Input capture signal timing: Input capture on the rising edge, falling edge, or both edges can be selected by settings in TIOR. Figure 10.25 shows the timing when the rising edge is selected. The pulse width of the input capture signal must be at least 1.5 system clocks for single-edge capture, and 2.5 system clocks for capture of both edges.

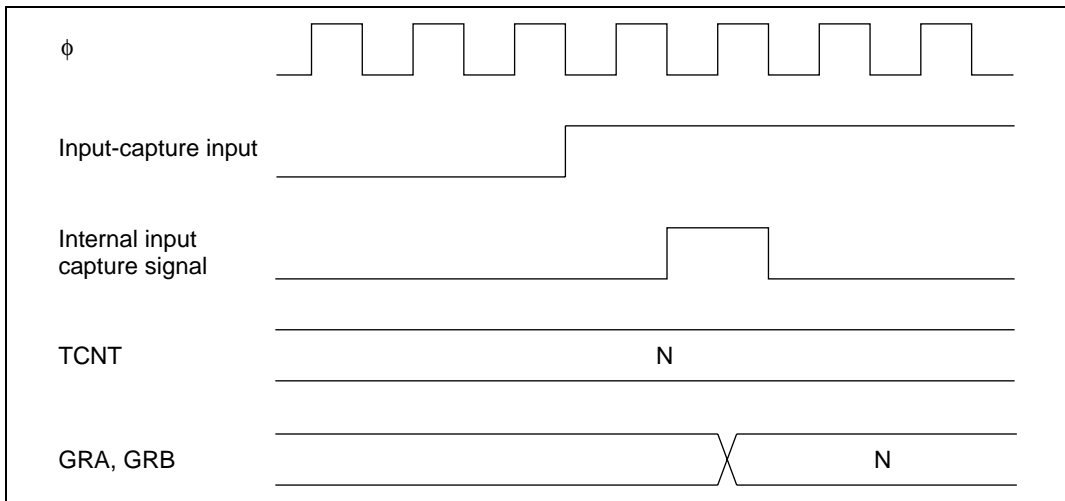

Figure 10.25 Input Capture Signal Timing

10.4.3 Synchronization

The synchronization function enables two or more timer counters to be synchronized by writing the same data to them simultaneously (synchronous preset). With appropriate TCR settings, two or more timer counters can also be cleared simultaneously (synchronous clear). Synchronization enables additional general registers to be associated with a single time base. Synchronization can be selected for all channels (0 to 4).

Sample Setup Procedure for Synchronization

Figure 10.26 shows a sample procedure for setting up synchronization.

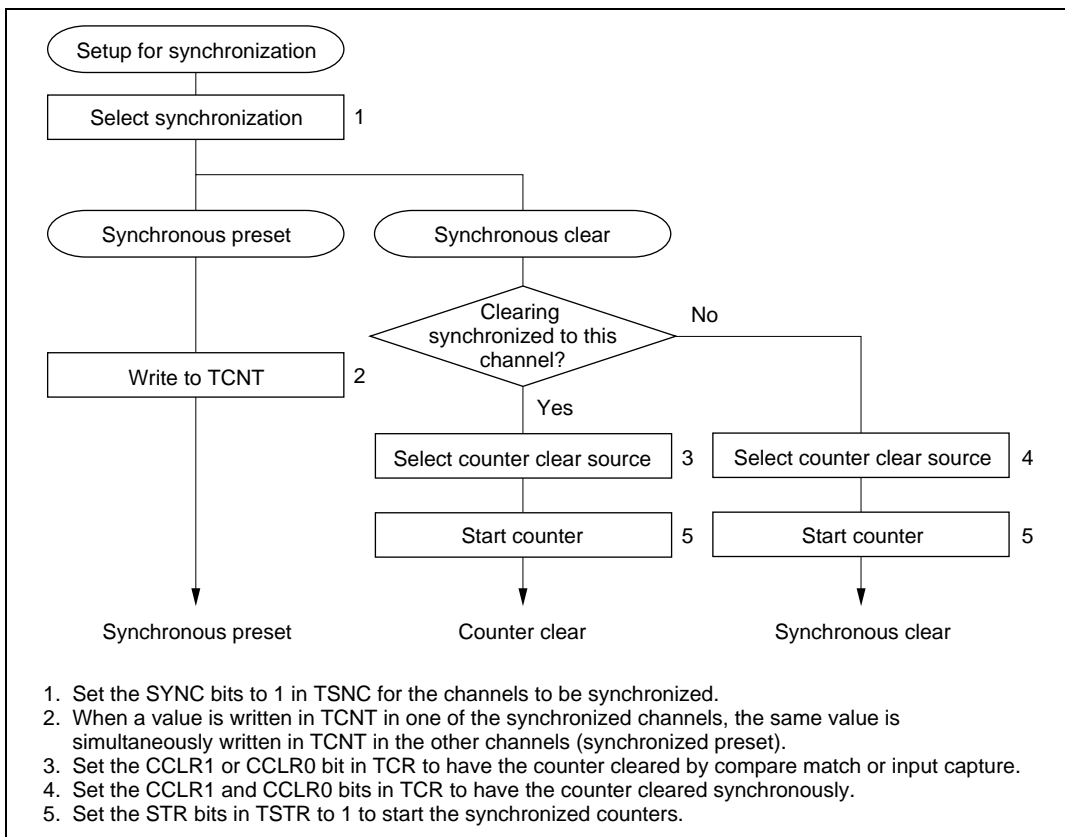

Figure 10.26 Setup Procedure for Synchronization (Example)

Example of Synchronization

Figure 10.27 shows an example of synchronization. Channels 0, 1, and 2 are synchronized, and are set to operate in PWM mode. Channel 0 is set for counter clearing by compare match with GRB0. Channels 1 and 2 are set for synchronous counter clearing. The timer counters in channels 0, 1, and 2 are synchronously preset, and are synchronously cleared by compare match with GRB0. A three-phase PWM waveform is output from pins TIOCA₀, TIOCA₁, and TIOCA₂. For further information on PWM mode, see section 10.4.4, PWM Mode.

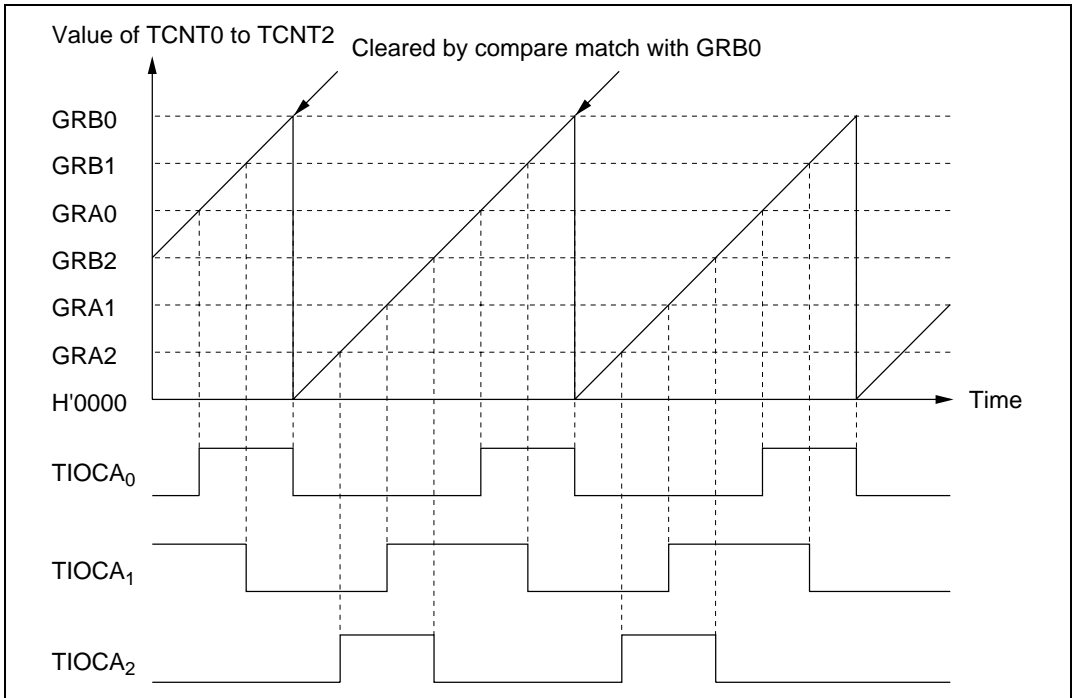

Figure 10.27 Synchronization (Example)

10.4.4 PWM Mode

In PWM mode GRA and GRB are paired and a PWM waveform is output from the TIOCA pin. GRA specifies the time at which the PWM output changes to 1. GRB specifies the time at which the PWM output changes to 0. If either GRA or GRB is selected as the counter clear source, a PWM waveform with a duty cycle from 0% to 100% is output at the TIOCA pin. PWM mode can be selected in all channels (0 to 4).

Table 10.4 summarizes the PWM output pins and corresponding registers. If the same value is set in GRA and GRB, the output does not change when compare match occurs.

Table 10.4 PWM Output Pins and Registers

Channel	Output Pin	1 Output	0 Output
0	TIOCA ₀	GRA0	GRB0
1	TIOCA ₁	GRA1	GRB1
2	TIOCA ₂	GRA2	GRB2
3	TIOCA ₃	GRA3	GRB3
4	TIOCA ₄	GRA4	GRB4

Sample Setup Procedure for PWM Mode

Figure 10.28 shows a sample procedure for setting up PWM mode.

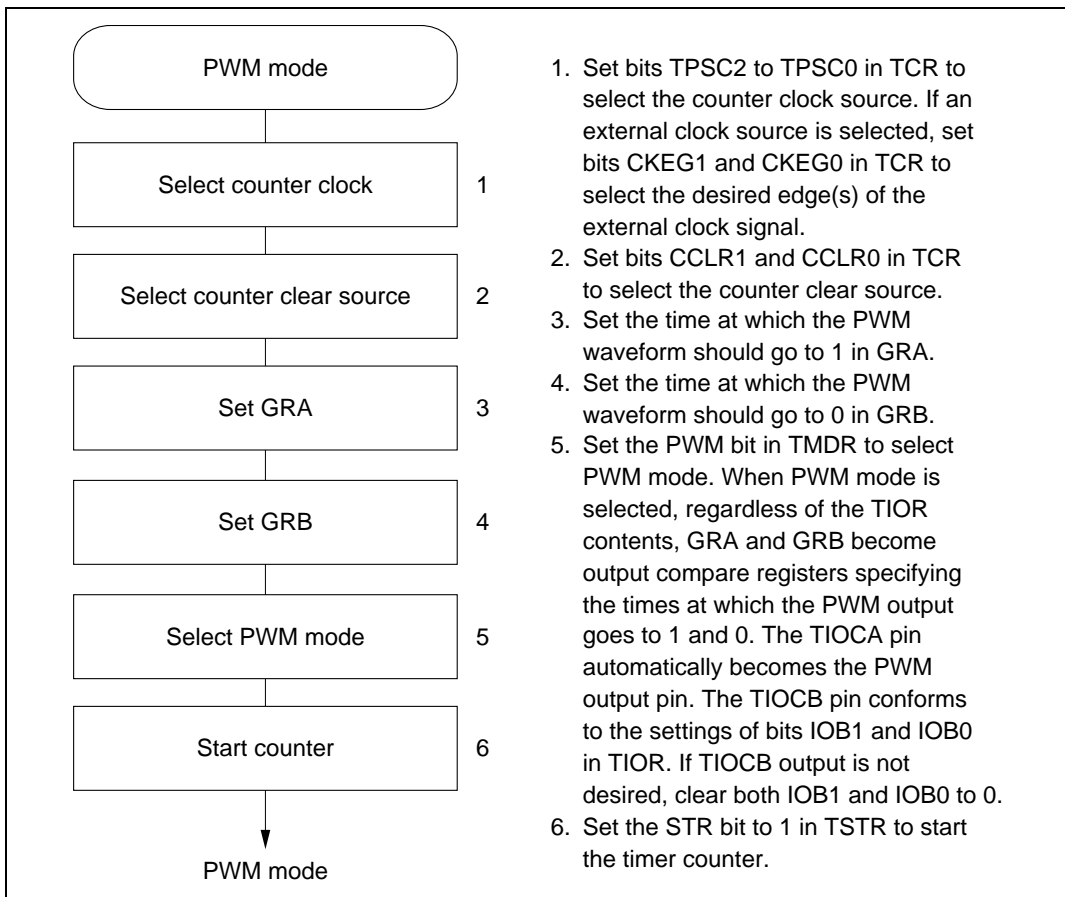

Figure 10.28 Setup Procedure for PWM Mode (Example)

Examples of PWM Mode

Figure 10.29 shows examples of operation in PWM mode. In PWM mode TIOCA becomes an output pin. The output goes to 1 at compare match with GRA, and to 0 at compare match with GRB.

In the examples shown, TCNT is cleared by compare match with GRA or GRB. Synchronized operation and free-running counting are also possible.

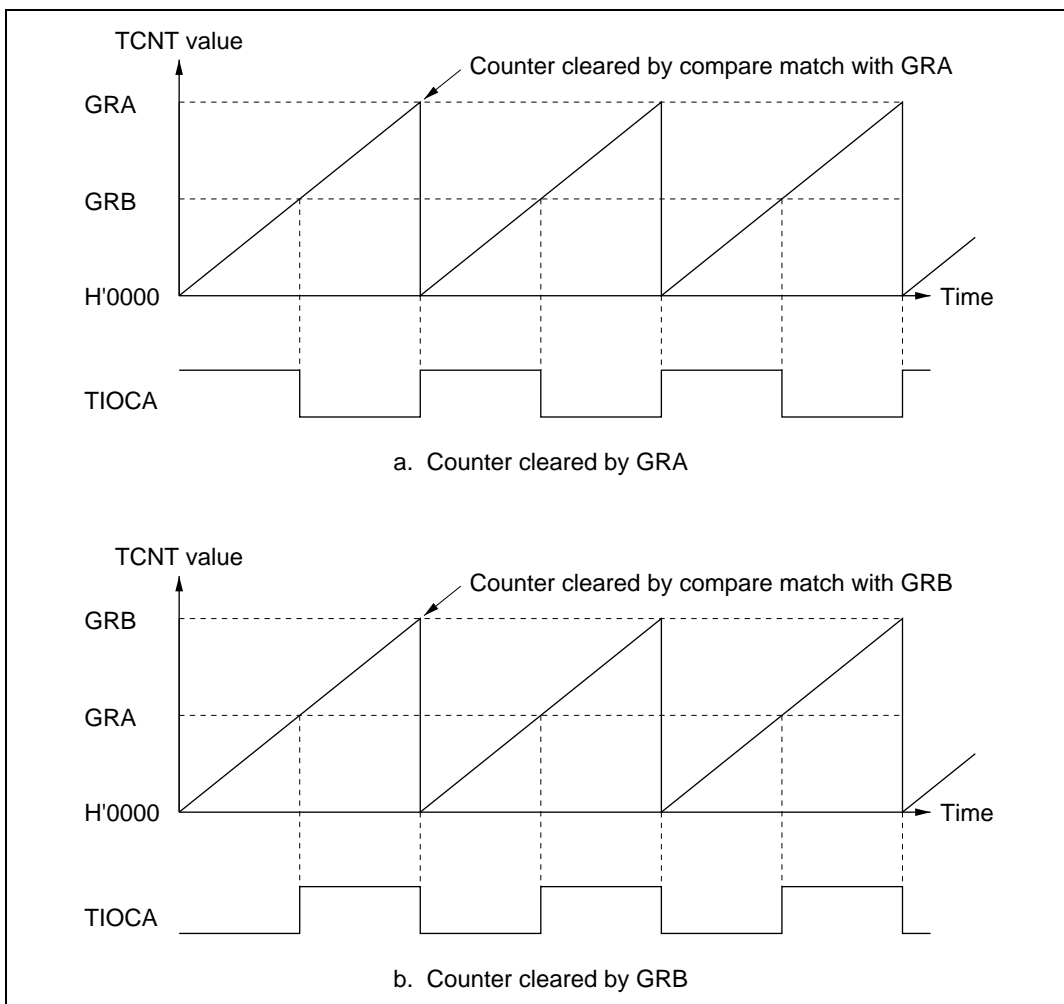

Figure 10.29 PWM Mode (Example 1)

Figure 10.30 shows examples of the output of PWM waveforms with duty cycles of 0% and 100%. If the counter is cleared by compare match with GRB, and GRA is set to a higher value than GRB, the duty cycle is 0%. If the counter is cleared by compare match with GRA, and GRB is set to a higher value than GRA, the duty cycle is 100%.

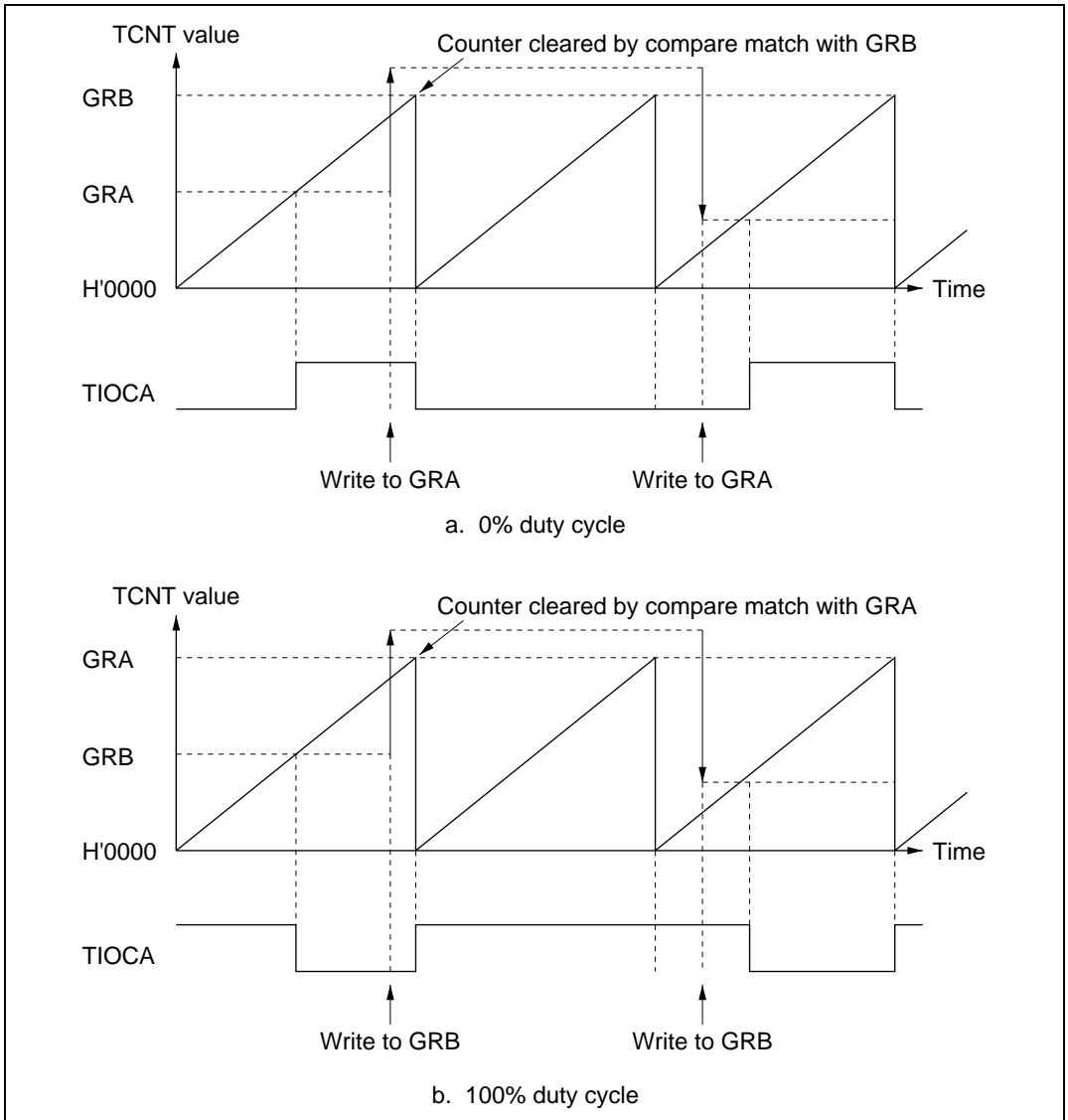

Figure 10.30 PWM Mode (Example 2)

10.4.5 Reset-Synchronized PWM Mode

In reset-synchronized PWM mode channels 3 and 4 are combined to produce three pairs of complementary PWM waveforms, all having one waveform transition point in common.

When reset-synchronized PWM mode is selected TIOCA₃, TIOCB₃, TIOCA₄, TOCXA₄, TIOCB₄, and TOCXB₄ automatically become PWM output pins, and TCNT3 functions as an up-counter.

Table 10.5 lists the PWM output pins. Table 10.6 summarizes the register settings.

Table 10.5 Output Pins in Reset-Synchronized PWM Mode

Channel	Output Pin	Description
3	TIOCA ₃	PWM output 1
	TIOCB ₃	PWM output 1' (complementary waveform to PWM output 1)
4	TIOCA ₄	PWM output 2
	TOCXA ₄	PWM output 2' (complementary waveform to PWM output 2)
	TIOCB ₄	PWM output 3
	TOCXB ₄	PWM output 3' (complementary waveform to PWM output 3)

Table 10.6 Register Settings in Reset-Synchronized PWM Mode

Register	Setting
TCNT3	Initially set to H'0000
TCNT4	Not used (operates independently)
GRA3	Specifies the count period of TCNT3
GRB3	Specifies a transition point of PWM waveforms output from TIOCA ₃ and TIOCB ₃
GRA4	Specifies a transition point of PWM waveforms output from TIOCA ₄ and TOCXA ₄
GRB4	Specifies a transition point of PWM waveforms output from TIOCB ₄ and TOCXB ₄

Sample Setup Procedure for Reset-Synchronized PWM Mode

Figure 10.31 shows a sample procedure for setting up reset-synchronized PWM mode.

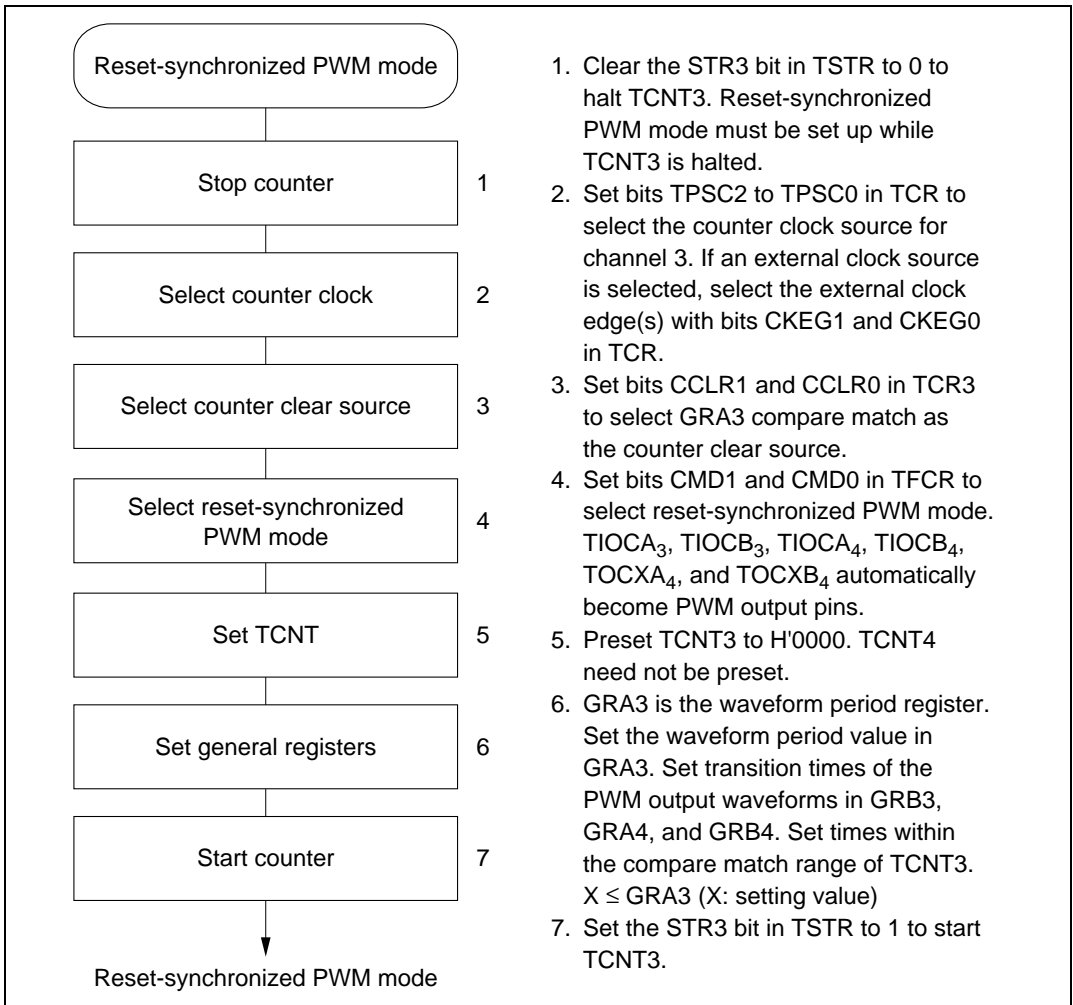

Figure 10.31 Setup Procedure for Reset-Synchronized PWM Mode (Example)

Example of Reset-Synchronized PWM Mode

Figure 10.32 shows an example of operation in reset-synchronized PWM mode. TCNT3 operates as an up-counter in this mode. TCNT4 operates independently, detached from GRA4 and GRB4. When TCNT3 matches GRA3, TCNT3 is cleared and resumes counting from H'0000. The PWM outputs toggle at compare match of TCNT3 with GRB3, GRA4, and GRB4 respectively, and all toggle when the counter is cleared.

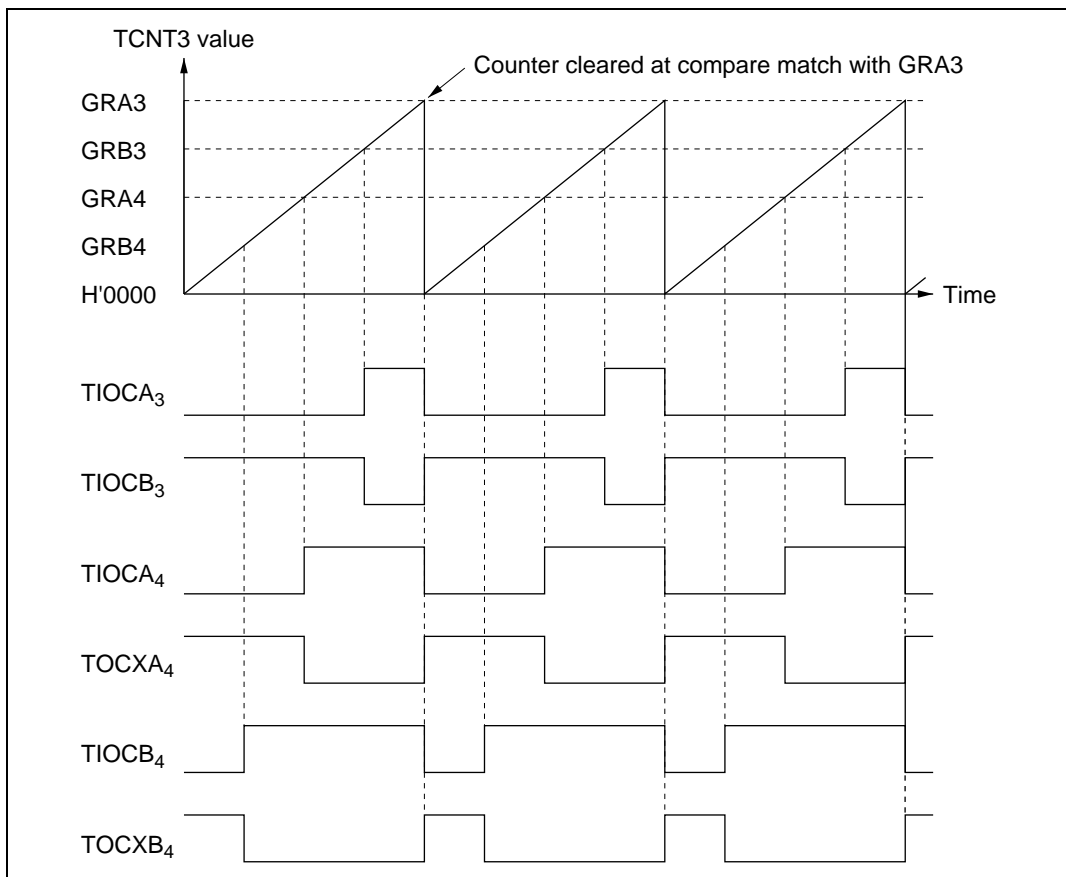

Figure 10.32 Operation in Reset-Synchronized PWM Mode (Example)
(when OLS3 = OLS4 = 1)

For the settings and operation when reset-synchronized PWM mode and buffer mode are both selected, see section 10.4.8, Buffering.

10.4.6 Complementary PWM Mode

In complementary PWM mode channels 3 and 4 are combined to output three pairs of complementary, non-overlapping PWM waveforms.

When complementary PWM mode is selected TIOCA₃, TIOCB₃, TIOCA₄, TOCXA₄, TIOCB₄, and TOCXB₄ automatically become PWM output pins, and TCNT3 and TCNT4 function as up/down-counters.

Table 10.7 lists the PWM output pins. Table 10.8 summarizes the register settings.

Table 10.7 Output Pins in Complementary PWM Mode

Channel	Output Pin	Description
3	TIOCA ₃	PWM output 1
	TIOCB ₃	PWM output 1' (non-overlapping complementary waveform to PWM output 1)
4	TIOCA ₄	PWM output 2
	TOCXA ₄	PWM output 2' (non-overlapping complementary waveform to PWM output 2)
	TIOCB ₄	PWM output 3
	TOCXB ₄	PWM output 3' (non-overlapping complementary waveform to PWM output 3)

Table 10.8 Register Settings in Complementary PWM Mode

Register	Setting
TCNT3	Initially specifies the non-overlap margin (difference to TCNT4)
TCNT4	Initially set to H'0000
GRA3	Specifies the upper limit value of TCNT3 minus 1
GRB3	Specifies a transition point of PWM waveforms output from TIOCA ₃ and TIOCB ₃
GRA4	Specifies a transition point of PWM waveforms output from TIOCA ₄ and TOCXA ₄
GRB4	Specifies a transition point of PWM waveforms output from TIOCB ₄ and TOCXB ₄

Setup Procedure for Complementary PWM Mode

Figure 10.33 shows a sample procedure for setting up complementary PWM mode.

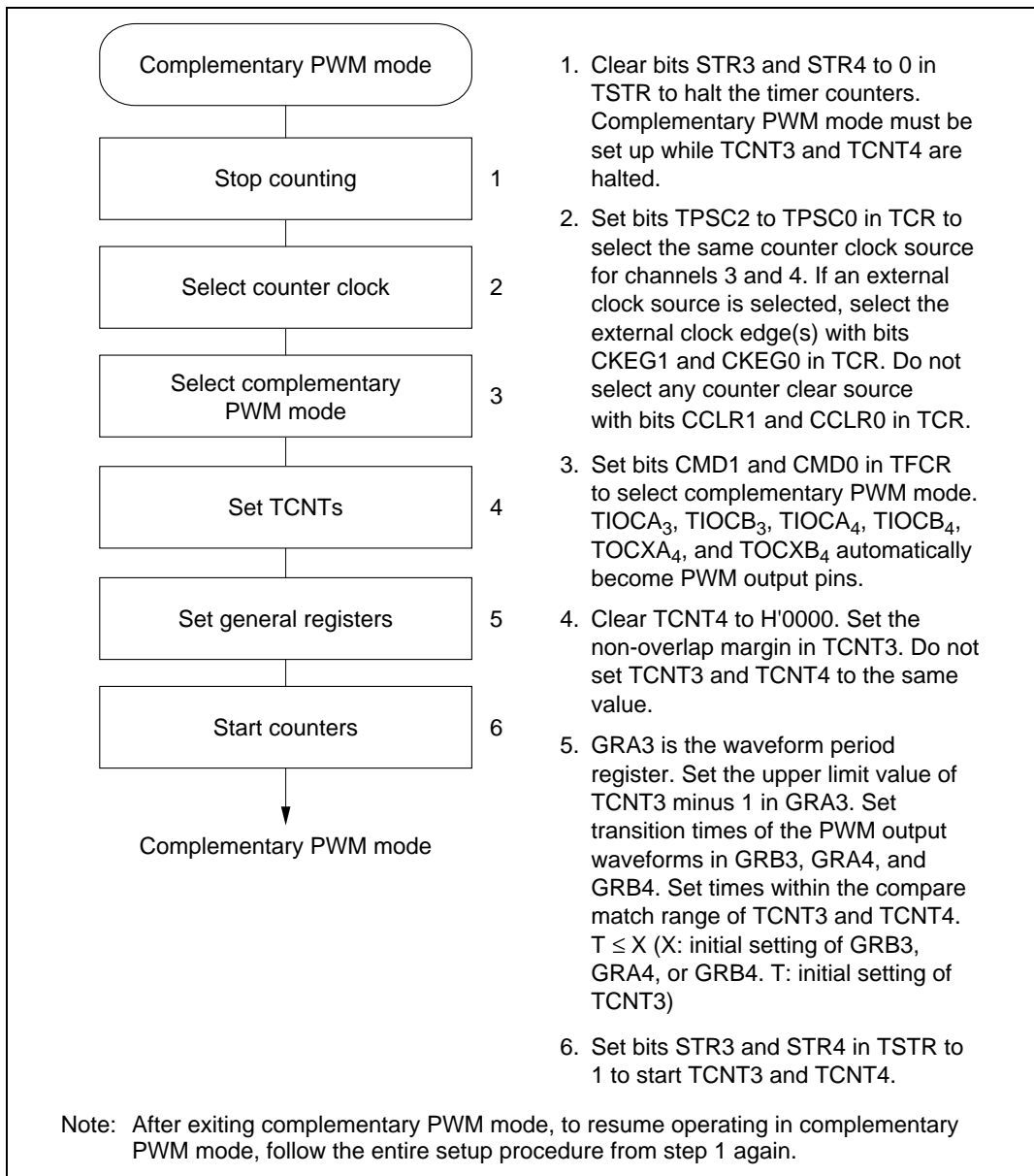

Figure 10.33 Setup Procedure for Complementary PWM Mode (Example)

Clearing Procedure for Complementary PWM Mode

Figure 10.34 shows the steps to clear complementary PWM mode.

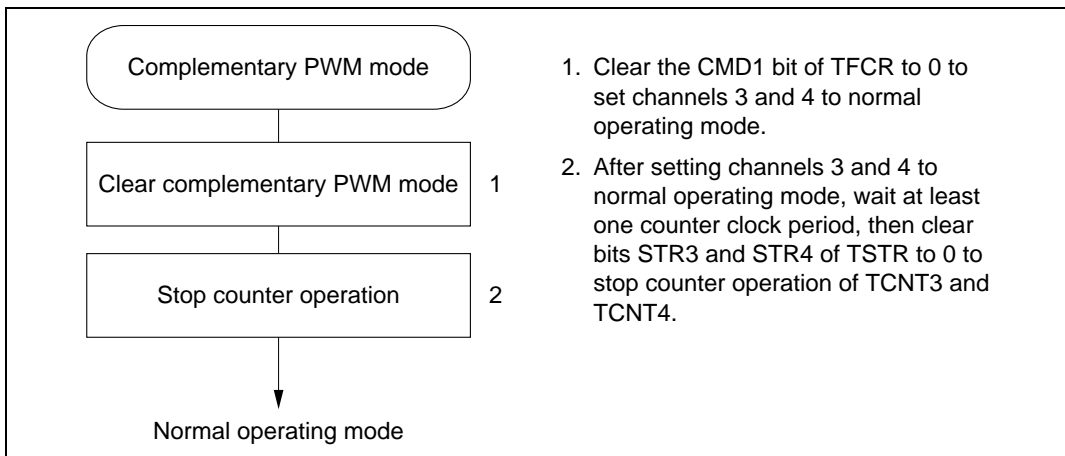

Figure 10.34 Clearing Procedure for Complementary PWM Mode

Examples of Complementary PWM Mode

Figure 10.35 shows an example of operation in complementary PWM mode. TCNT3 and TCNT4 operate as up/down-counters, counting down from compare match between TCNT3 and GRA3 and counting up from the point at which TCNT4 underflows. During each up-and-down counting cycle, PWM waveforms are generated by compare match with general registers GRB3, GRA4, and GRB4. Since TCNT3 is initially set to a higher value than TCNT4, compare match events occur in the sequence TCNT3, TCNT4, TCNT4, TCNT3.

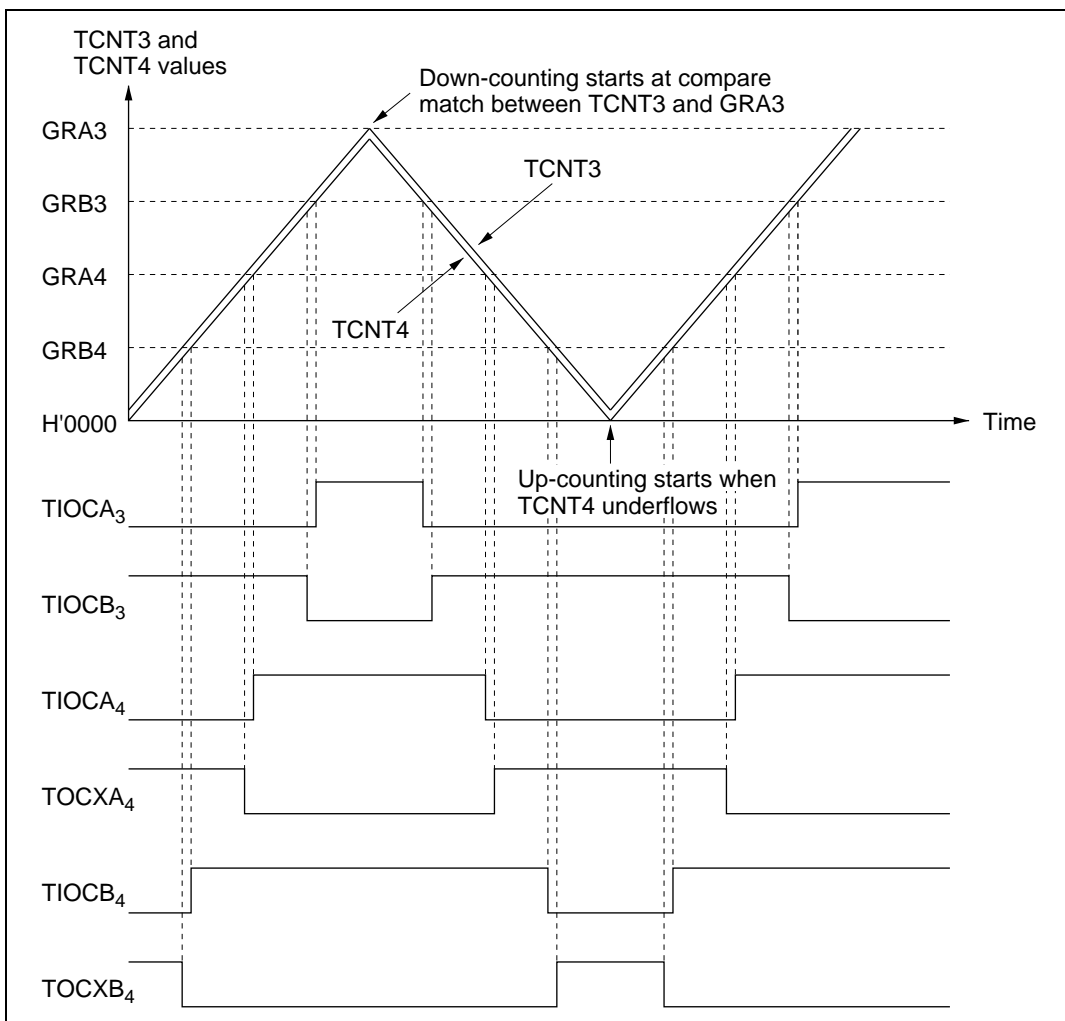

Figure 10.35 Operation in Complementary PWM Mode (Example 1, OLS3 = OLS4 = 1)

Figure 10.36 shows examples of waveforms with 0% and 100% duty cycles (in one phase) in complementary PWM mode. In this example the outputs change at compare match with GRB3, so waveforms with duty cycles of 0% or 100% can be output by setting GRB3 to a value larger than GRA3. The duty cycle can be changed easily during operation by use of the buffer registers. For further information see section 10.4.8, Buffering.

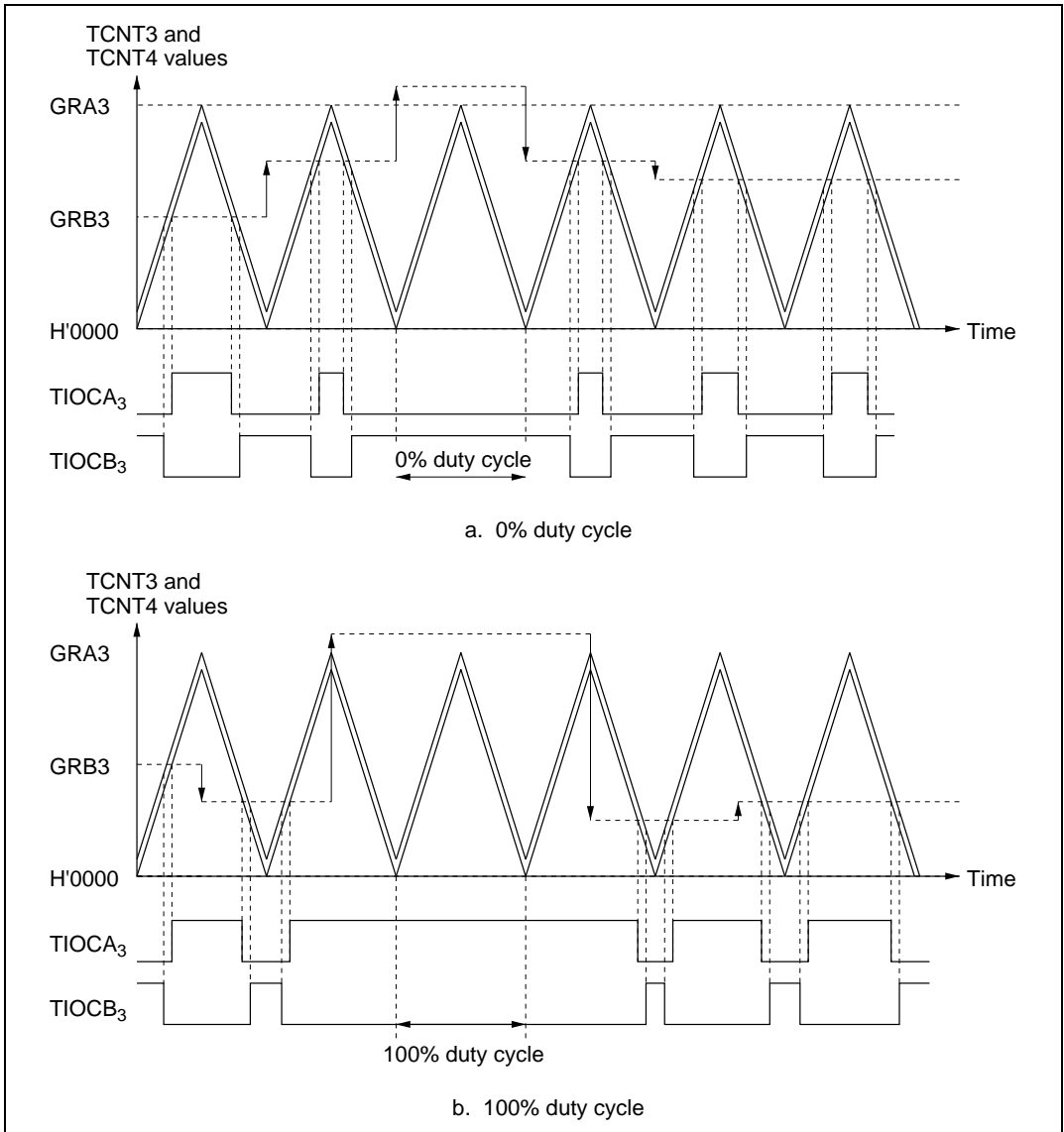

Figure 10.36 Operation in Complementary PWM Mode (Example 2, OLS3 = OLS4 = 1)

In complementary PWM mode, TCNT3 and TCNT4 overshoot and undershoot at the transitions between up-counting and down-counting. The setting conditions for the IMFA bit in channel 3 and the OVF bit in channel 4 differ from the usual conditions. In buffered operation the buffer transfer conditions also differ. Timing diagrams are shown in figures 10.37 and 10.38.

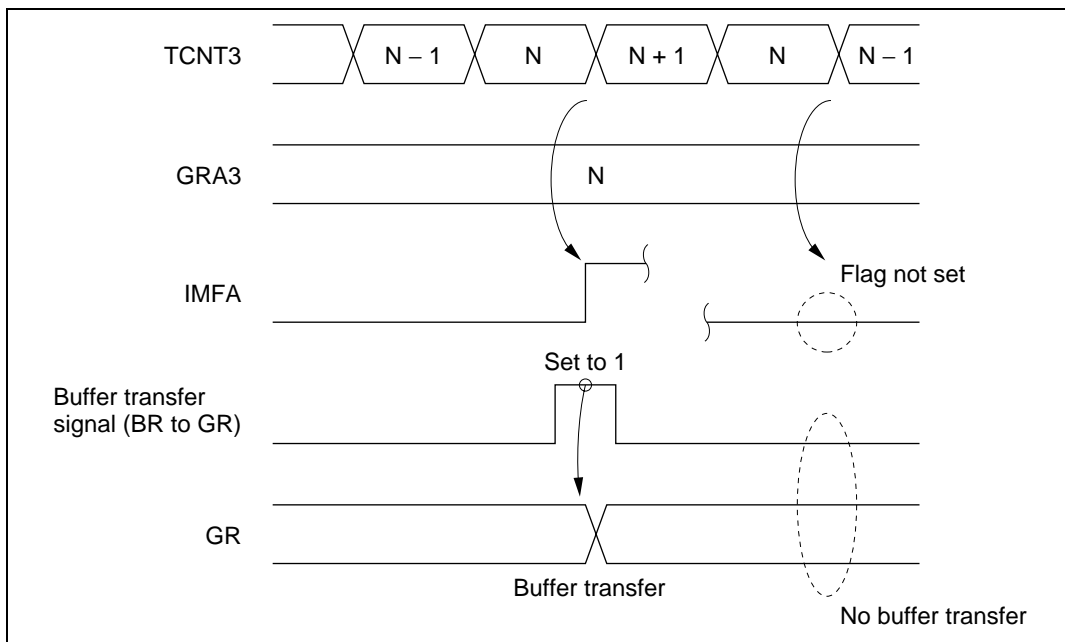

Figure 10.37 Overshoot Timing

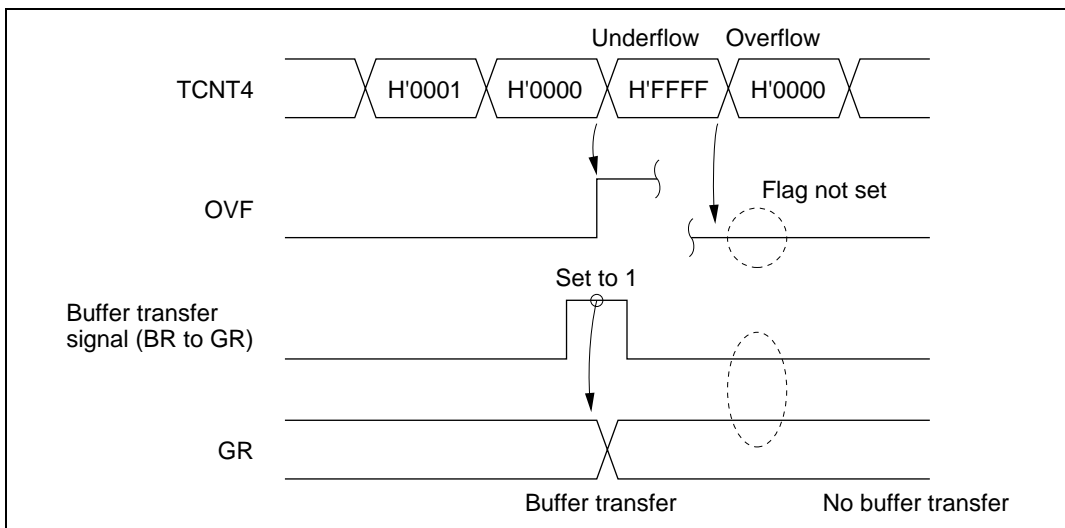

Figure 10.38 Undershoot Timing

In channel 3, IMFA is set to 1 only during up-counting. In channel 4, OVF is set to 1 only when an underflow occurs. When buffering is selected, buffer register contents are transferred to the general register at compare match A3 during up-counting, and when TCNT4 underflows.

General Register Settings in Complementary PWM Mode

When setting up general registers for complementary PWM mode or changing their settings during operation, note the following points.

- **Initial settings**
Do not set values from H'0000 to $T - 1$ (where T is the initial value of TCNT3). After the counters start and the first compare match A3 event has occurred, however, settings in this range also become possible.
- **Changing settings**
Use the buffer registers. Correct waveform output may not be obtained if a general register is written to directly.
- **Cautions on changes of general register settings**
Figure 10.39 shows six correct examples and one incorrect example.

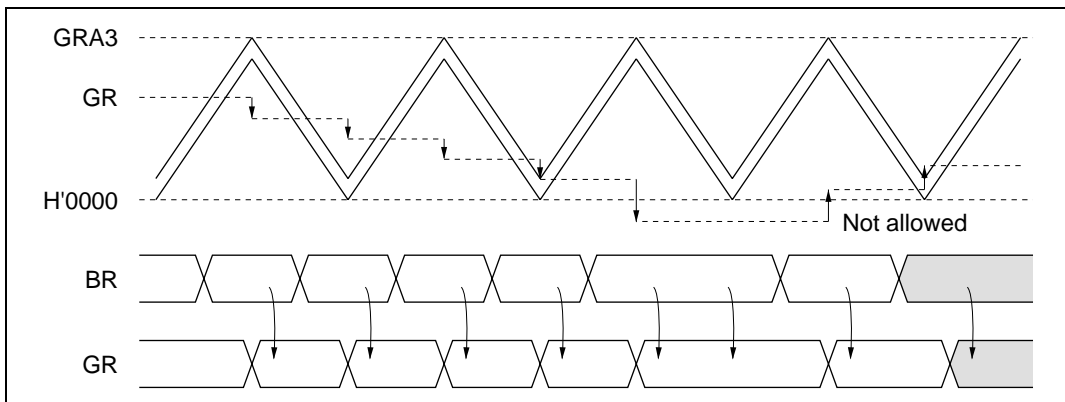

Figure 10.39 Changing a General Register Setting by Buffer Transfer (Example 1)

— Buffer transfer at transition from up-counting to down-counting

If the general register value is in the range from $GRA3 - T + 1$ to $GRA3$, do not transfer a buffer register value outside this range. Conversely, if the general register value is outside this range, do not transfer a value within this range. See figure 10.40.

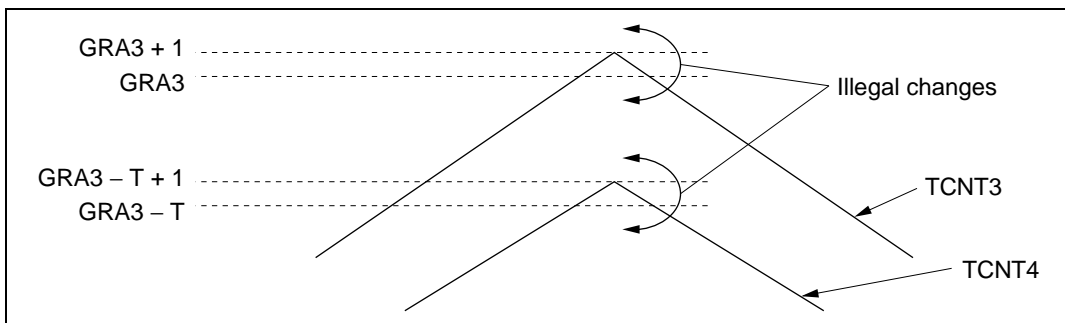

Figure 10.40 Changing a General Register Setting by Buffer Transfer (Caution 1)

— Buffer transfer at transition from down-counting to up-counting

If the general register value is in the range from $H'0000$ to $T - 1$, do not transfer a buffer register value outside this range. Conversely, when a general register value is outside this range, do not transfer a value within this range. See figure 10.41.

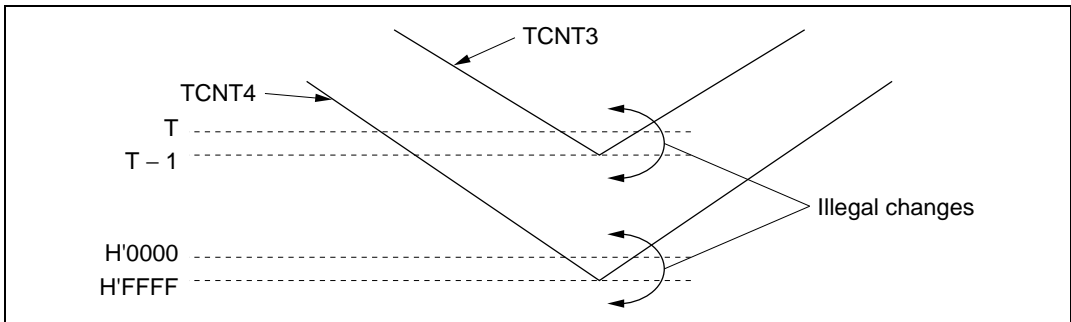

Figure 10.41 Changing a General Register Setting by Buffer Transfer (Caution 2)

— General register settings outside the counting range (H'0000 to GRA3)

Waveforms with a duty cycle of 0% or 100% can be output by setting a general register to a value outside the counting range. When a buffer register is set to a value outside the counting range, then later restored to a value within the counting range, the counting direction (up or down) must be the same both times. See figure 10.42.

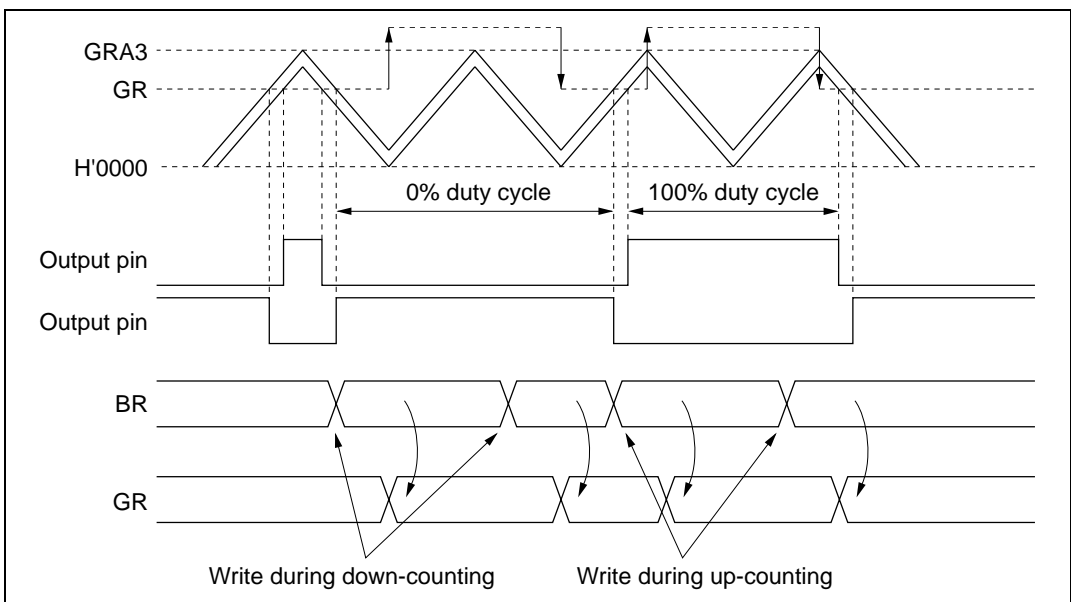

Figure 10.42 Changing a General Register Setting by Buffer Transfer (Example 2)

Settings can be made in this way by detecting GRA3 compare match or TCNT4 underflow before writing to the buffer register. They can also be made by using GRA3 compare match to activate the DMAC.

10.4.7 Phase Counting Mode

In phase counting mode the phase difference between two external clock inputs (at the TCLKA and TCLKB pins) is detected, and TCNT2 counts up or down accordingly.

In phase counting mode, the TCLKA and TCLKB pins automatically function as external clock input pins and TCNT2 becomes an up/down-counter, regardless of the settings of bits TPSC2 to TPSC0, CKEG1, and CKEG0 in TCR2. Settings of bits CCLR1, CCLR0 in TCR2, and settings in TIOR2, TIER2, TSR2, GRA2, and GRB2 are valid. The input capture and output compare functions can be used, and interrupts can be generated.

Phase counting is available only in channel 2.

Sample Setup Procedure for Phase Counting Mode

Figure 10.43 shows a sample procedure for setting up phase counting mode.

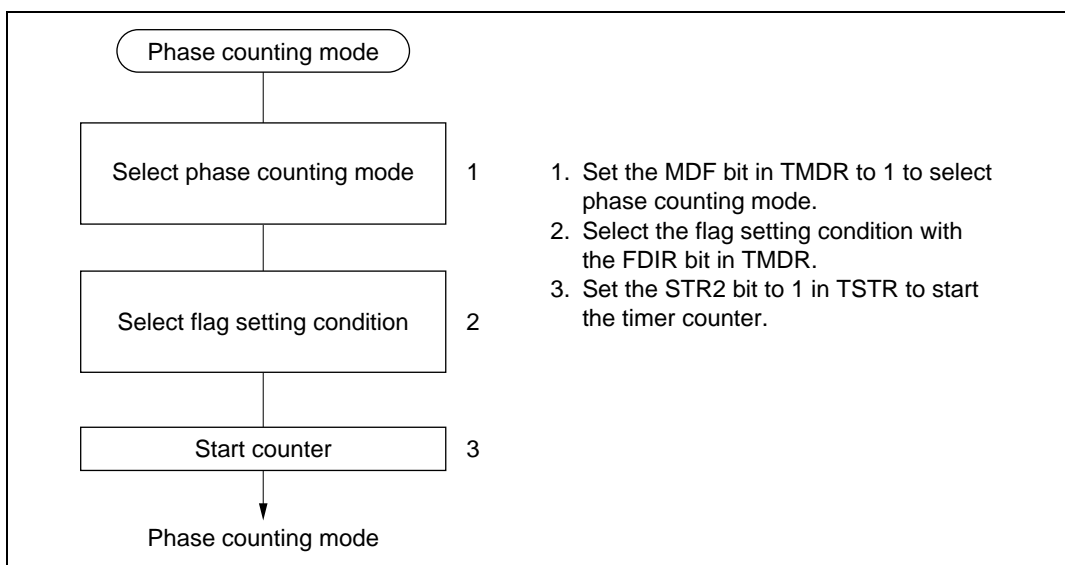

Figure 10.43 Setup Procedure for Phase Counting Mode (Example)

Example of Phase Counting Mode

Figure 10.44 shows an example of operations in phase counting mode. Table 10.9 lists the up-counting and down-counting conditions for TCNT2.

In phase counting mode both the rising and falling edges of TCLKA and TCLKB are counted. The phase difference between TCLKA and TCLKB must be at least 1.5 states, the phase overlap must also be at least 1.5 states, and the pulse width must be at least 2.5 states. See figure 10.45.

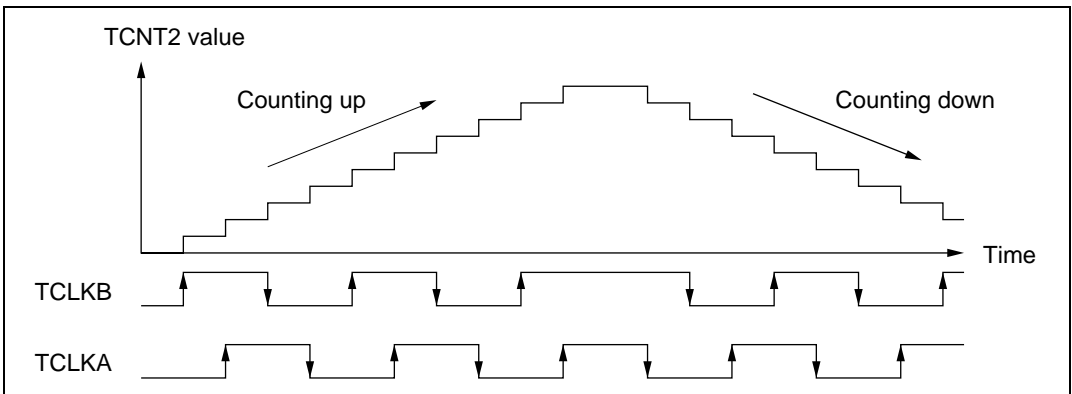

Figure 10.44 Operation in Phase Counting Mode (Example)

Table 10.9 Up/Down Counting Conditions

Counting Direction	Up-Counting				Down-Counting			
	↑	High	↓	Low	High	↓	Low	↑
TCLKB	↑	High	↓	Low	High	↓	Low	↑
TCLKA	Low	↑	High	↓	↓	Low	↑	High

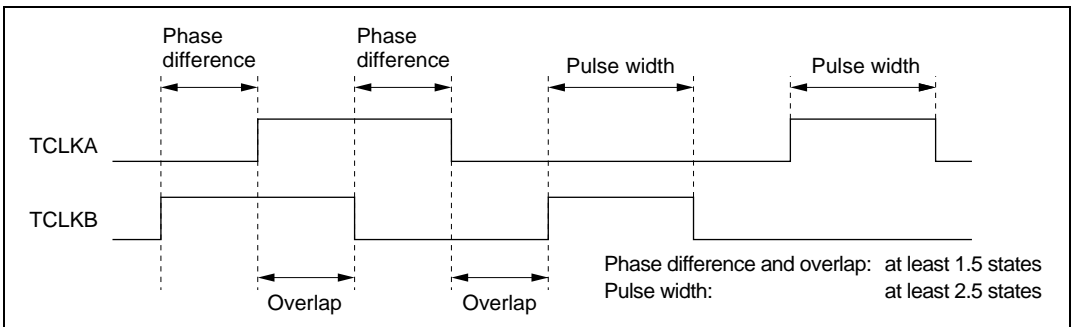

Figure 10.45 Phase Difference, Overlap, and Pulse Width in Phase Counting Mode

10.4.8 Buffering

Buffering operates differently depending on whether a general register is an output compare register or an input capture register, with further differences in reset-synchronized PWM mode and complementary PWM mode. Buffering is available only in channels 3 and 4. Buffering operations under the conditions mentioned above are described next.

- General register used for output compare

The buffer register value is transferred to the general register at compare match.

See figure 10.46.

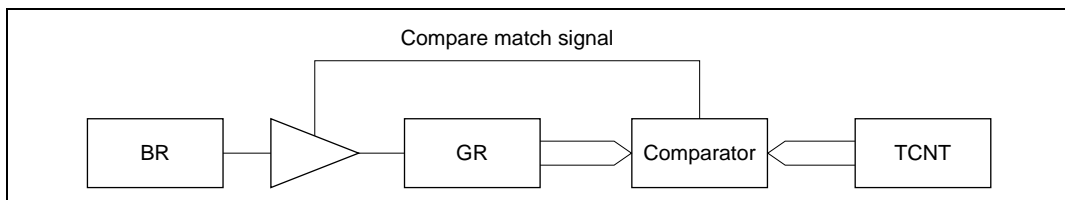

Figure 10.46 Compare Match Buffering

- General register used for input capture

The TCNT value is transferred to the general register at input capture. The previous general register value is transferred to the buffer register.

See figure 10.47.

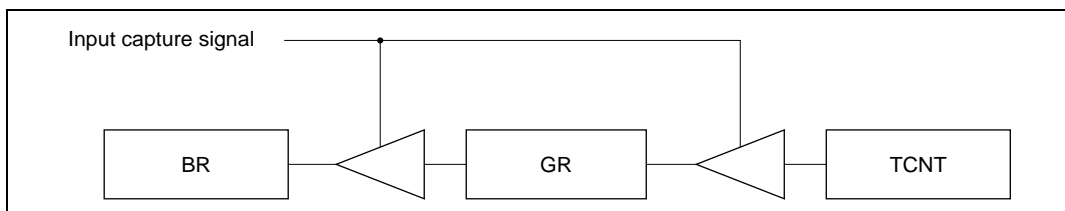

Figure 10.47 Input Capture Buffering

- Complementary PWM mode

The buffer register value is transferred to the general register when TCNT3 and TCNT4 change counting direction. This occurs at the following two times:

- When TCNT3 compare matches GRA3
- When TCNT4 underflows

- Reset-synchronized PWM mode

The buffer register value is transferred to the general register at compare match A3.

Sample Buffering Setup Procedure

Figure 10.48 shows a sample buffering setup procedure.

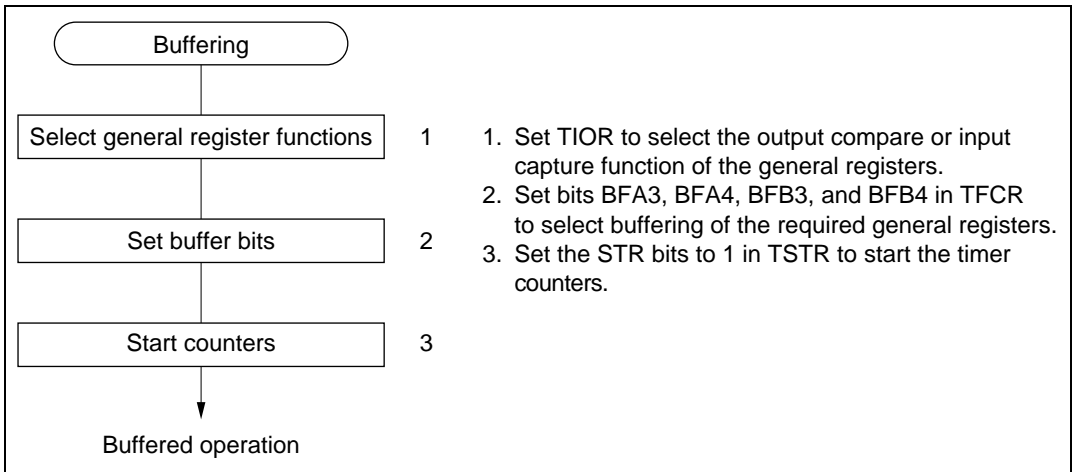

Figure 10.48 Buffering Setup Procedure (Example)

Examples of Buffering

Figure 10.49 shows an example in which GRA is set to function as an output compare register buffered by BRA, TCNT is set to operate as a periodic counter cleared by GRB compare match, and TIOCA and TIOCB are set to toggle at compare match A and B. Because of the buffer setting, when TIOCA toggles at compare match A, the BRA value is simultaneously transferred to GRA. This operation is repeated each time compare match A occurs. Figure 10.50 shows the transfer timing.

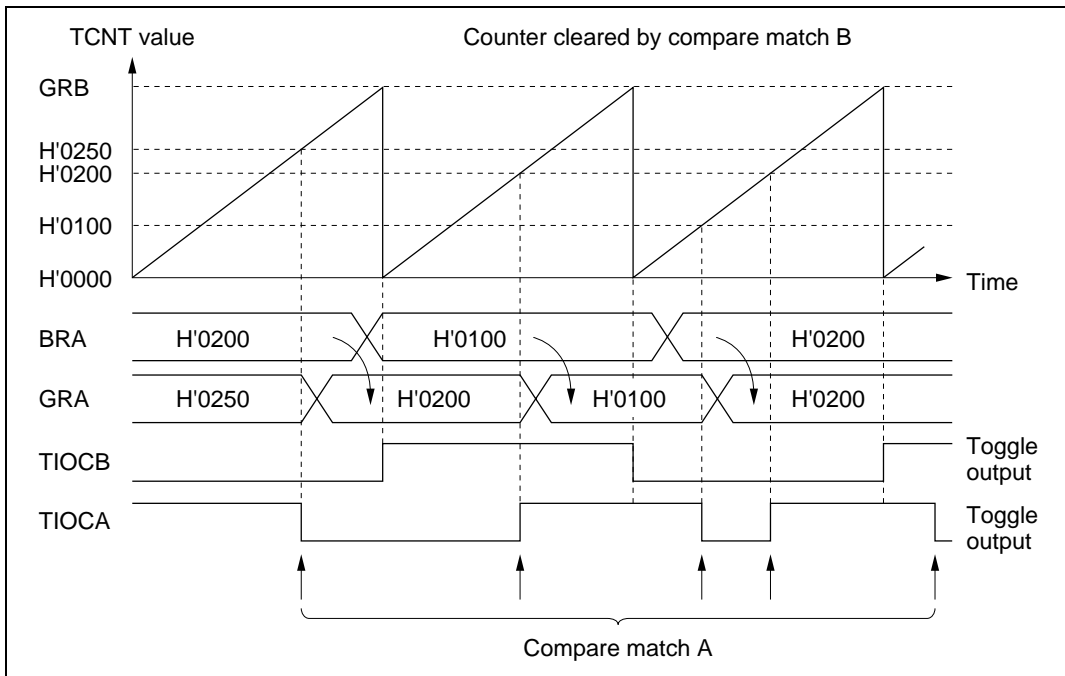

Figure 10.49 Register Buffering (Example 1: Buffering of Output Compare Register)

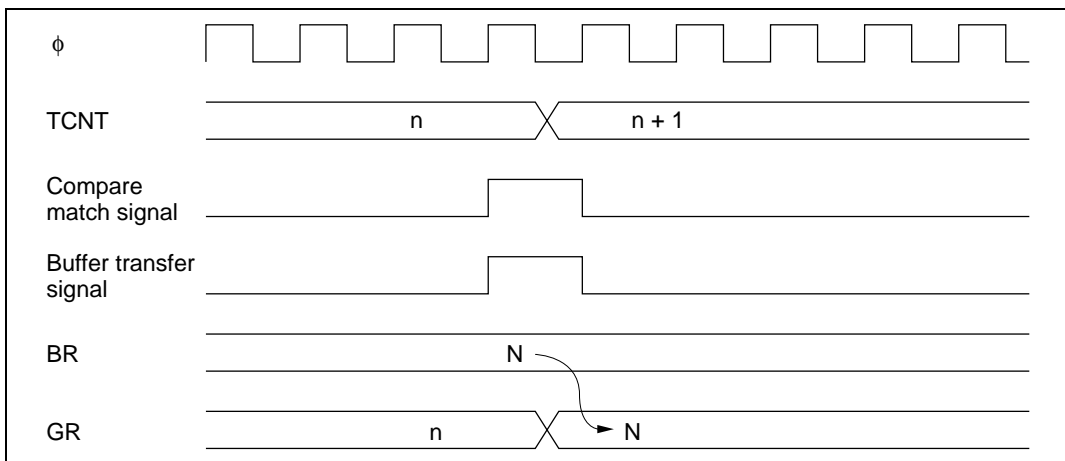

Figure 10.50 Compare Match and Buffer Transfer Timing (Example)

Figure 10.51 shows an example in which GRA is set to function as an input capture register buffered by BRA, and TCNT is cleared by input capture B. The falling edge is selected as the input capture edge at TIOCB. Both edges are selected as input capture edges at TIOCA. Because

of the buffer setting, when the TCNT value is captured into GRA at input capture A, the previous GRA value is simultaneously transferred to BRA. Figure 10.52 shows the transfer timing.

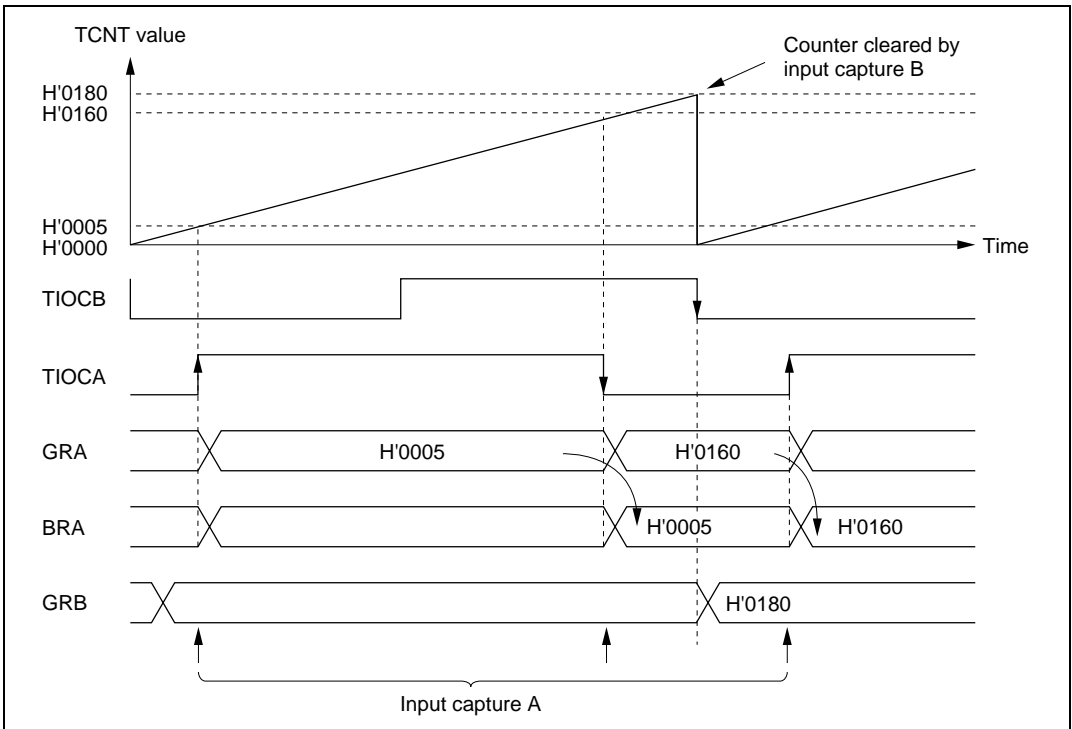

Figure 10.51 Register Buffering (Example 2: Buffering of Input Capture Register)

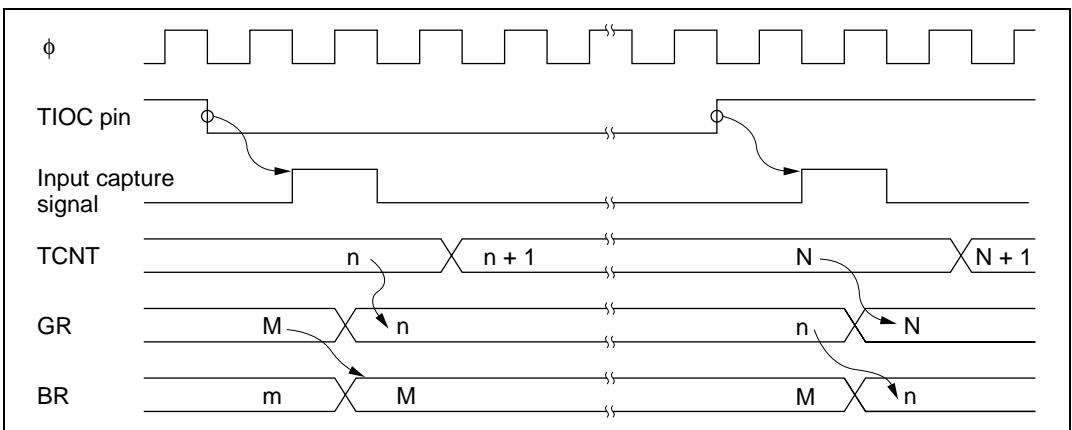

Figure 10.52 Input Capture and Buffer Transfer Timing (Example)

Figure 10.53 shows an example in which GRB3 is buffered by BRB3 in complementary PWM mode. Buffering is used to set GRB3 to a higher value than GRA3, generating a PWM waveform with 0% duty cycle. The BRB3 value is transferred to GRB3 when TCNT3 matches GRA3, and when TCNT4 underflows.

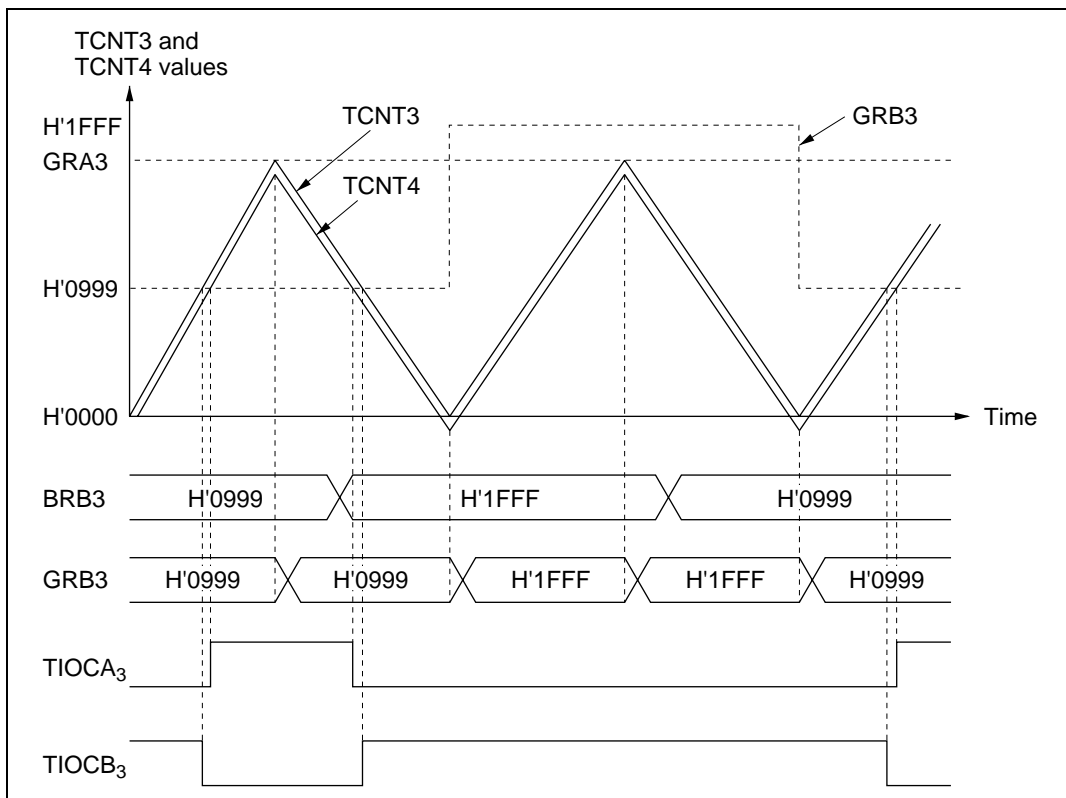

Figure 10.53 Register Buffering (Example 3: Buffering in Complementary PWM Mode)

10.4.9 ITU Output Timing

The ITU outputs from channels 3 and 4 can be disabled by bit settings in TOER or by an external trigger, or inverted by bit settings in TOCR.

Timing of Enabling and Disabling of ITU Output by TOER

In this example an ITU output is disabled by clearing a master enable bit to 0 in TOER. An arbitrary value can be output by appropriate settings of the data register (DR) and data direction register (DDR) of the corresponding input/output port. Figure 10.54 illustrates the timing of the enabling and disabling of ITU output by TOER.

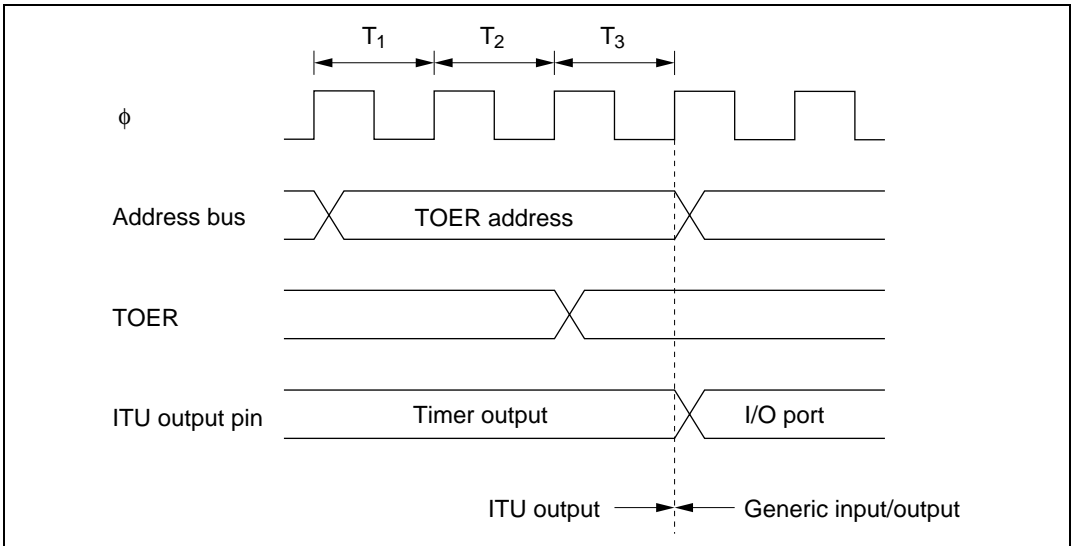

Figure 10.54 Timing of Disabling of ITU Output by Writing to TOER (Example)

Timing of Disabling of ITU Output by External Trigger

If the XTGD bit is cleared to 0 in TOCR in reset-synchronized PWM mode or complementary PWM mode, when an input capture A signal occurs in channel 1, the master enable bits are cleared to 0 in TOER, disabling ITU output. Figure 10.55 shows the timing.

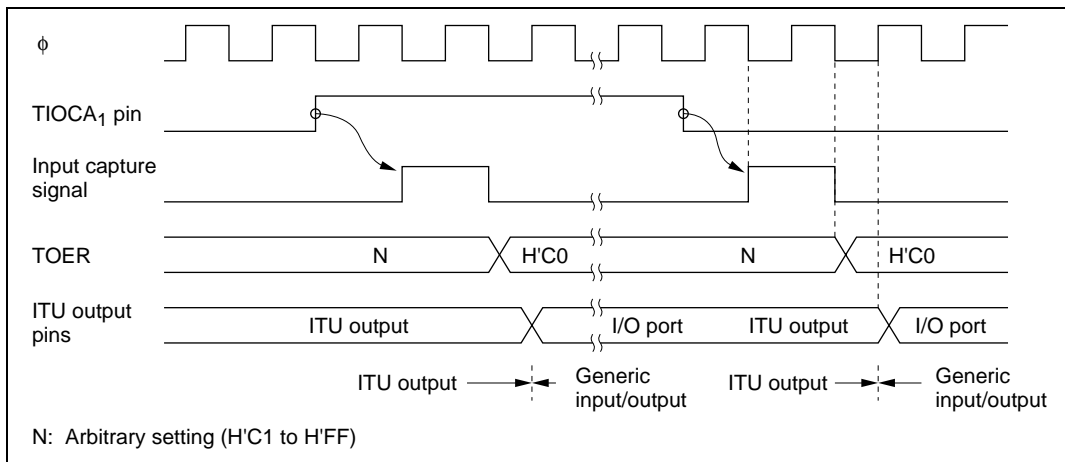

Figure 10.55 Timing of Disabling of ITU Output by External Trigger (Example)

Timing of Output Inversion by TOCR

The output levels in reset-synchronized PWM mode and complementary PWM mode can be inverted by inverting the output level select bits (OLS4 and OLS3) in TOCR. Figure 10.56 shows the timing.

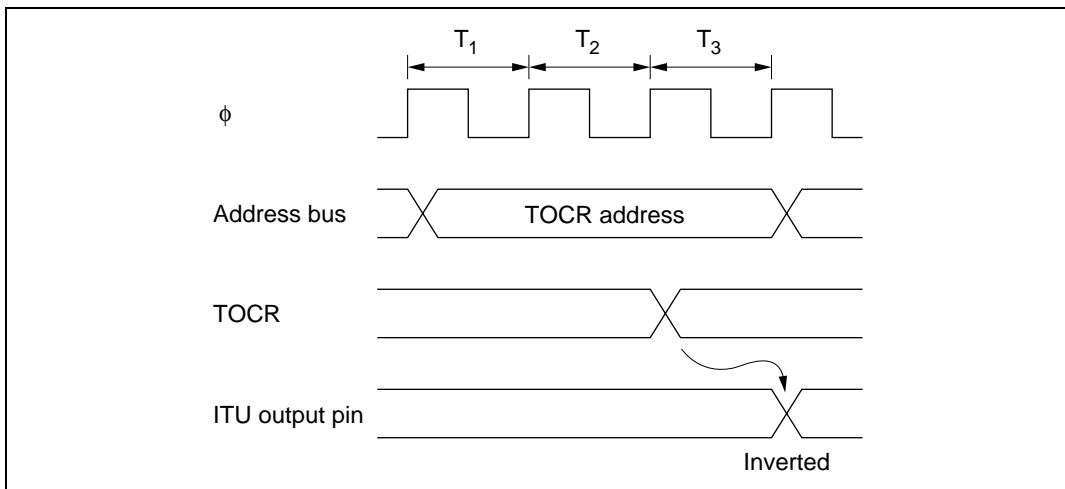

Figure 10.56 Timing of Inverting of ITU Output Level by Writing to TOCR (Example)

10.5 Interrupts

The ITU has two types of interrupts: input capture/compare match interrupts, and overflow interrupts.

10.5.1 Setting of Status Flags

Timing of Setting of IMFA and IMFB at Compare Match

IMFA and IMFB are set to 1 by a compare match signal generated when TCNT matches a general register (GR). The compare match signal is generated in the last state in which the values match (when TCNT is updated from the matching count to the next count). Therefore, when TCNT matches a general register, the compare match signal is not generated until the next timer clock input. Figure 10.57 shows the timing of the setting of IMFA and IMFB.

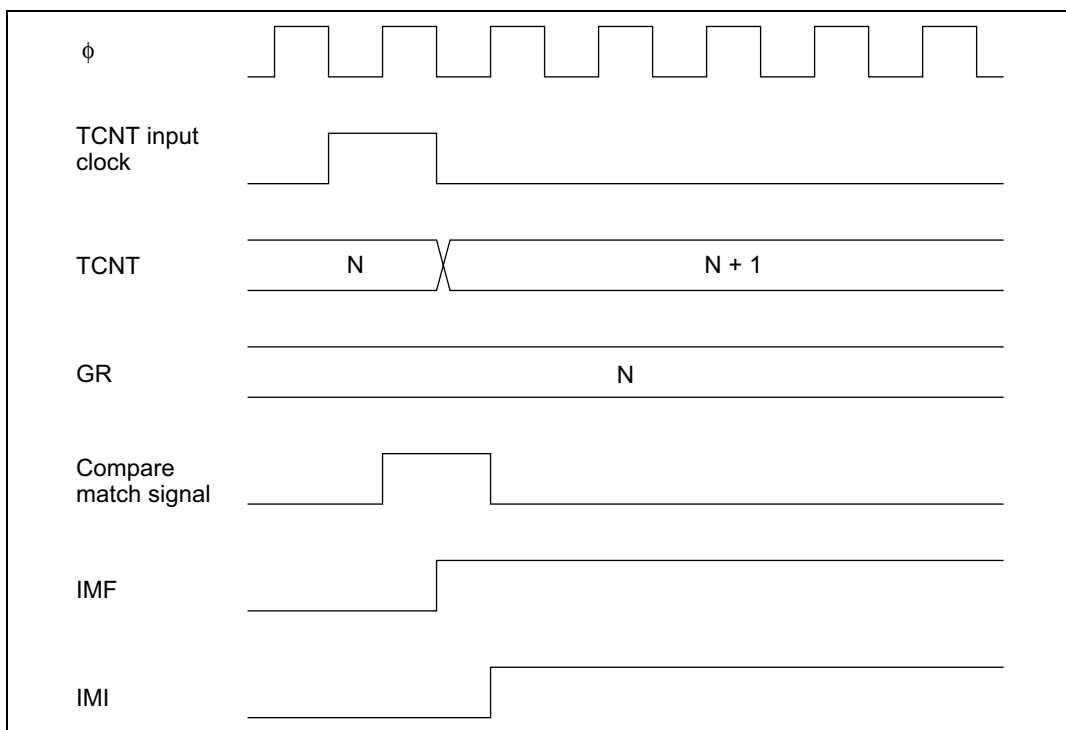

Figure 10.57 Timing of Setting of IMFA and IMFB by Compare Match

Timing of Setting of IMFA and IMFB by Input Capture

IMFA and IMFB are set to 1 by an input capture signal. The TCNT contents are simultaneously transferred to the corresponding general register. Figure 10.58 shows the timing.

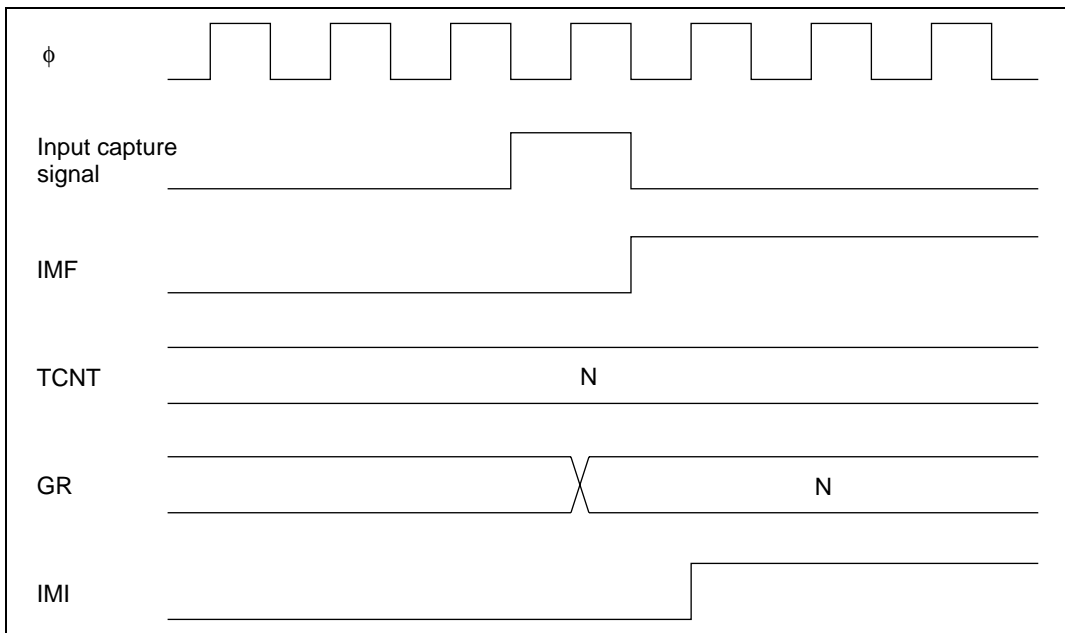

Figure 10.58 Timing of Setting of IMFA and IMFB by Input Capture

Timing of Setting of Overflow Flag (OVF)

OVF is set to 1 when TCNT overflows from H'FFFF to H'0000 or underflows from H'0000 to H'FFFF. Figure 10.59 shows the timing.

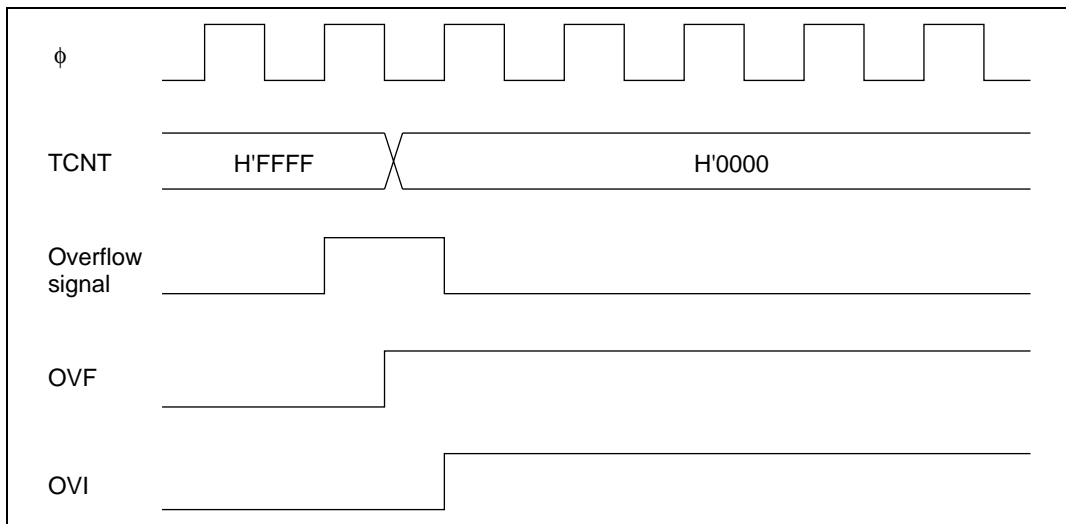

Figure 10.59 Timing of Setting of OVF

10.5.2 Timing of Clearing of Status Flags

If the CPU reads a status flag while it is set to 1, then writes 0 in the status flag, the status flag is cleared. Figure 10.60 shows the timing.

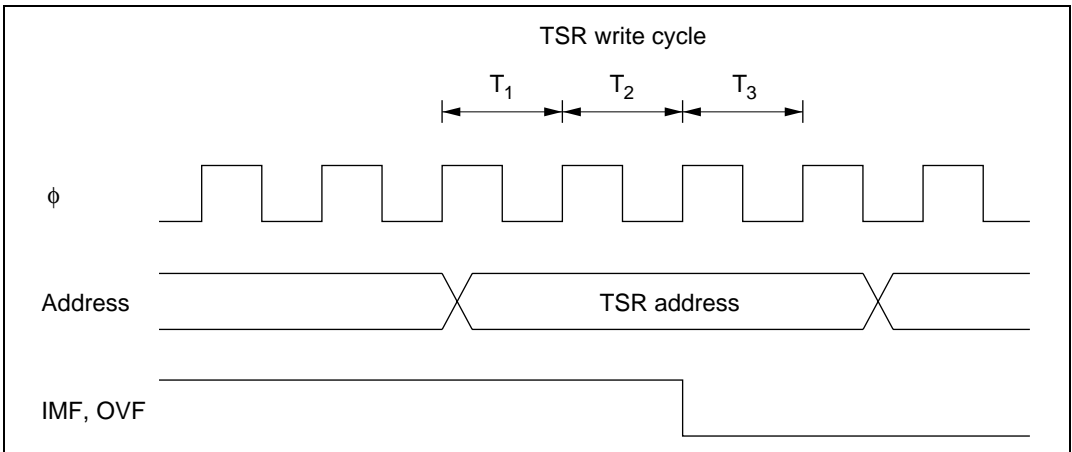

Figure 10.60 Timing of Clearing of Status Flags

10.5.3 Interrupt Sources and DMA Controller Activation

Each ITU channel can generate a compare match/input capture A interrupt, a compare match/input capture B interrupt, and an overflow interrupt. In total there are 15 interrupt sources, all independently vectored. An interrupt is requested when the interrupt request flag and interrupt enable bit are both set to 1.

The priority order of the channels can be modified in interrupt priority registers A and B (IPRA and IPRB). For details see section 5, Interrupt Controller.

Compare match/input capture A interrupts in channels 0 to 3 can activate the DMA controller (DMAC). When the DMAC is activated a CPU interrupt is not requested.

Table 10.10 lists the interrupt sources.

Table 10.10 ITU Interrupt Sources

Channel	Interrupt Source	Description	DMAC Activatable	Priority*
0	IMIA0	Compare match/input capture A0	Yes	High ↑ Low
	IMIB0	Compare match/input capture B0	No	
	OVI0	Overflow 0	No	
1	IMIA1	Compare match/input capture A1	Yes	
	IMIB1	Compare match/input capture B1	No	
	OVI1	Overflow 1	No	
2	IMIA2	Compare match/input capture A2	Yes	
	IMIB2	Compare match/input capture B2	No	
	OVI2	Overflow 2	No	
3	IMIA3	Compare match/input capture A3	Yes	
	IMIB3	Compare match/input capture B3	No	
	OVI3	Overflow 3	No	
4	IMIA4	Compare match/input capture A4	No	
	IMIB4	Compare match/input capture B4	No	
	OVI4	Overflow 4	No	

Note: * The priority immediately after a reset is indicated. Inter-channel priorities can be changed by settings in IPRA and IPRB.

10.6 Usage Notes

This section describes contention and other matters requiring special attention during ITU operations.

Contention between TCNT Write and Clear

If a counter clear signal occurs in the T_3 state of a TCNT write cycle, clearing of the counter takes priority and the write is not performed. See figure 10.61.

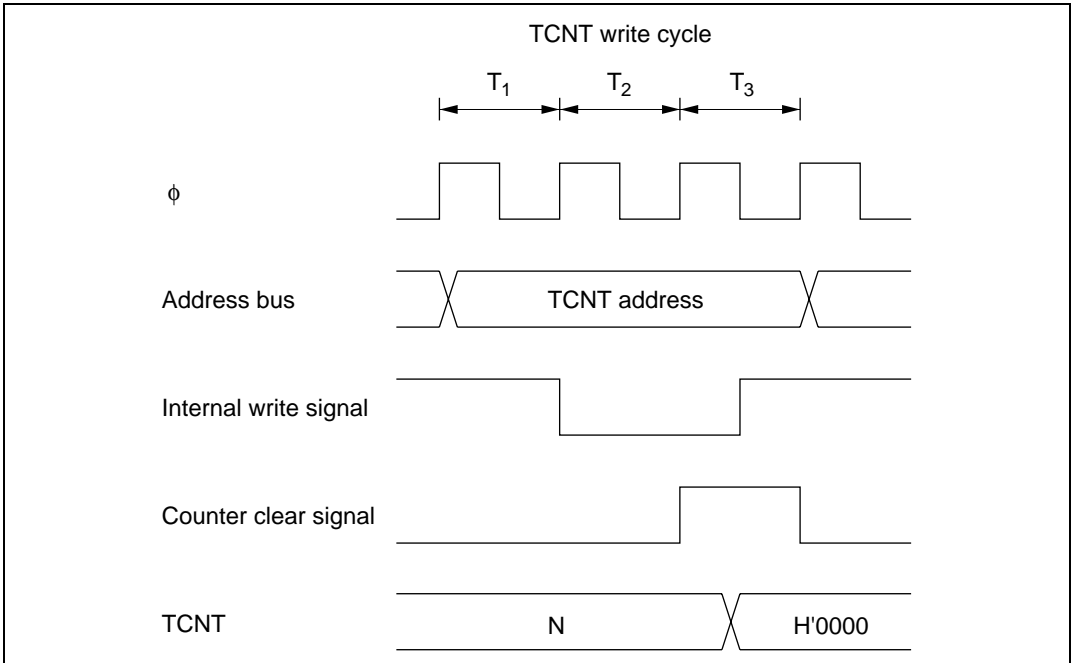

Figure 10.61 Contention between TCNT Write and Clear

Contention between TCNT Word Write and Increment

If an increment pulse occurs in the T_3 state of a TCNT word write cycle, writing takes priority and TCNT is not incremented. See figure 10.62.

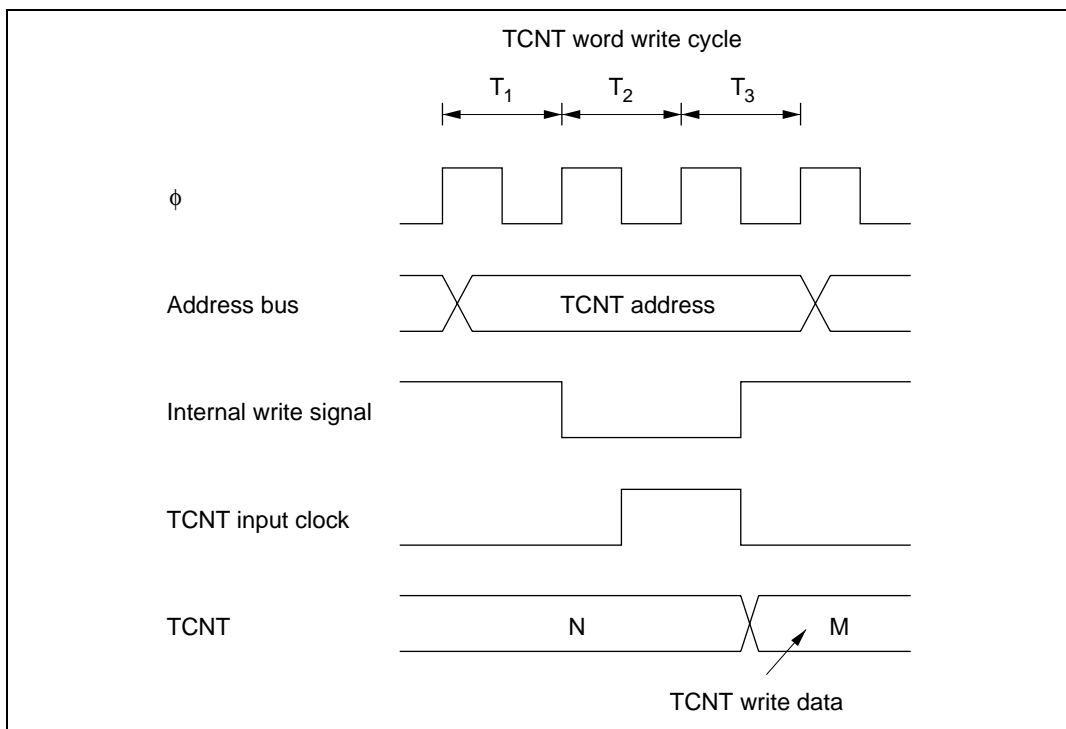

Figure 10.62 Contention between TCNT Word Write and Increment

Contention between TCNT Byte Write and Increment

If an increment pulse occurs in the T_2 or T_3 state of a TCNT byte write cycle, writing takes priority and TCNT is not incremented. The TCNT byte that was not written retains its previous value. See figure 10.63, which shows an increment pulse occurring in the T_2 state of a byte write to TCNTH.

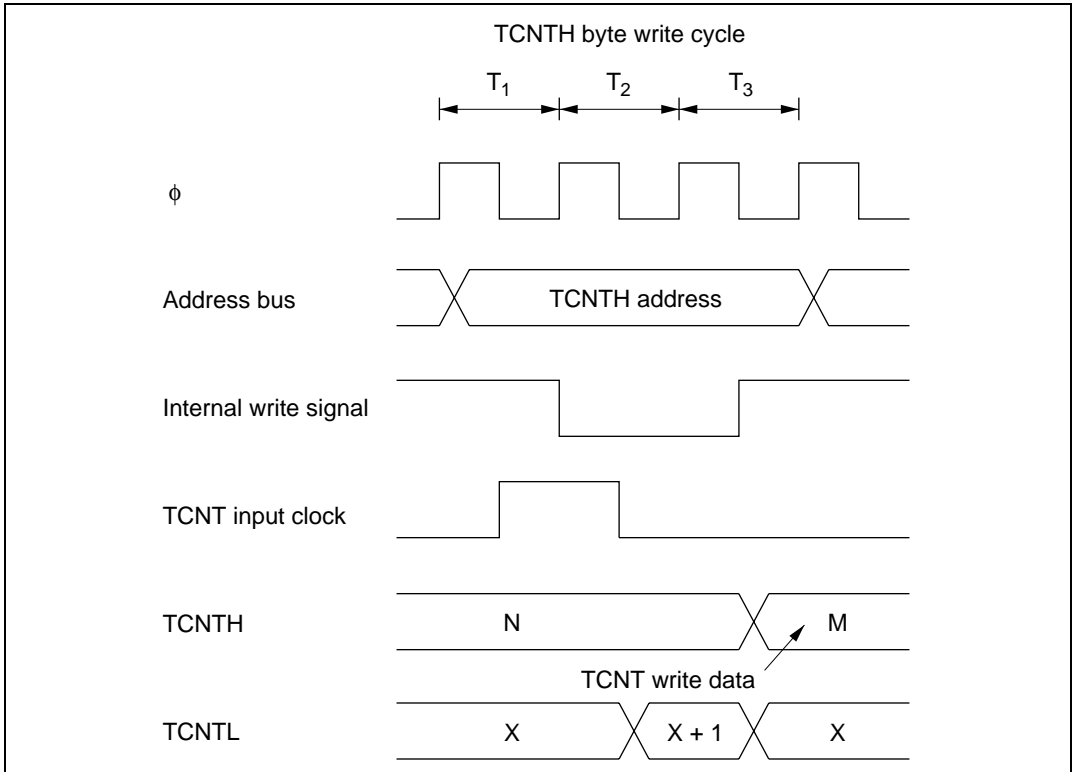

Figure 10.63 Contention between TCNT Byte Write and Increment

Contention between General Register Write and Compare Match

If a compare match occurs in the T_3 state of a general register write cycle, writing takes priority and the compare match signal is inhibited. See figure 10.64.

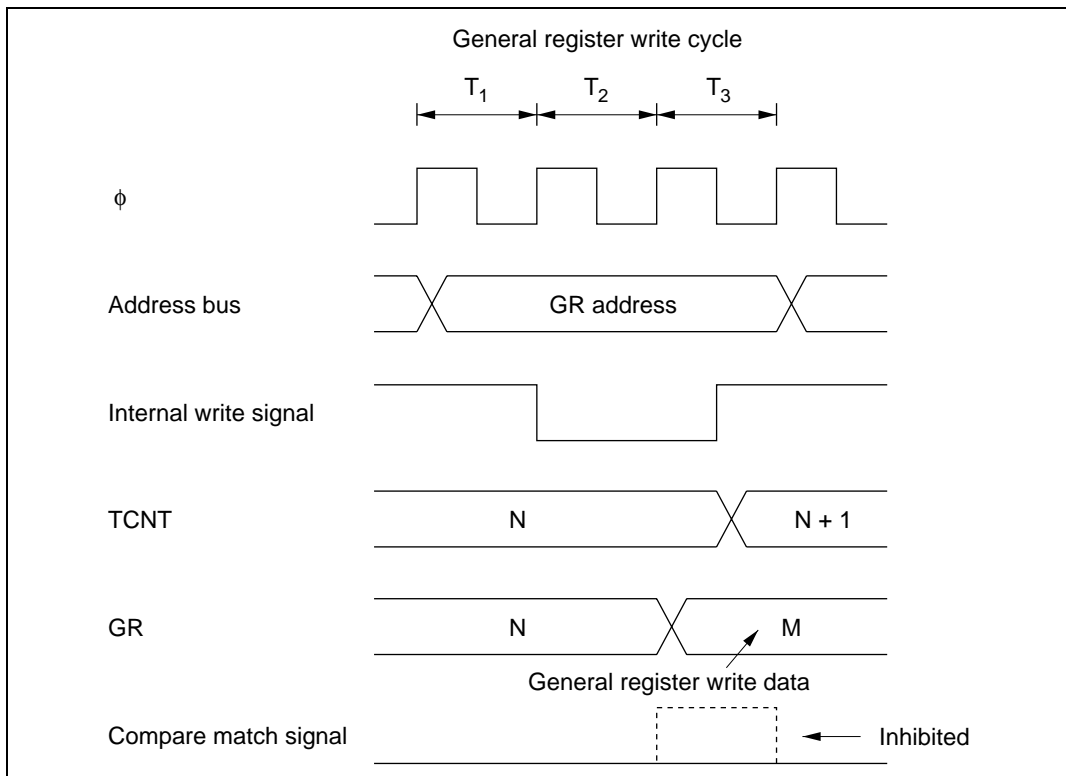

Figure 10.64 Contention between General Register Write and Compare Match

Contention between TCNT Write and Overflow or Underflow

If an overflow occurs in the T_3 state of a TCNT write cycle, writing takes priority and the counter is not incremented. OVF is set to 1. The same holds for underflow. See figure 10.65.

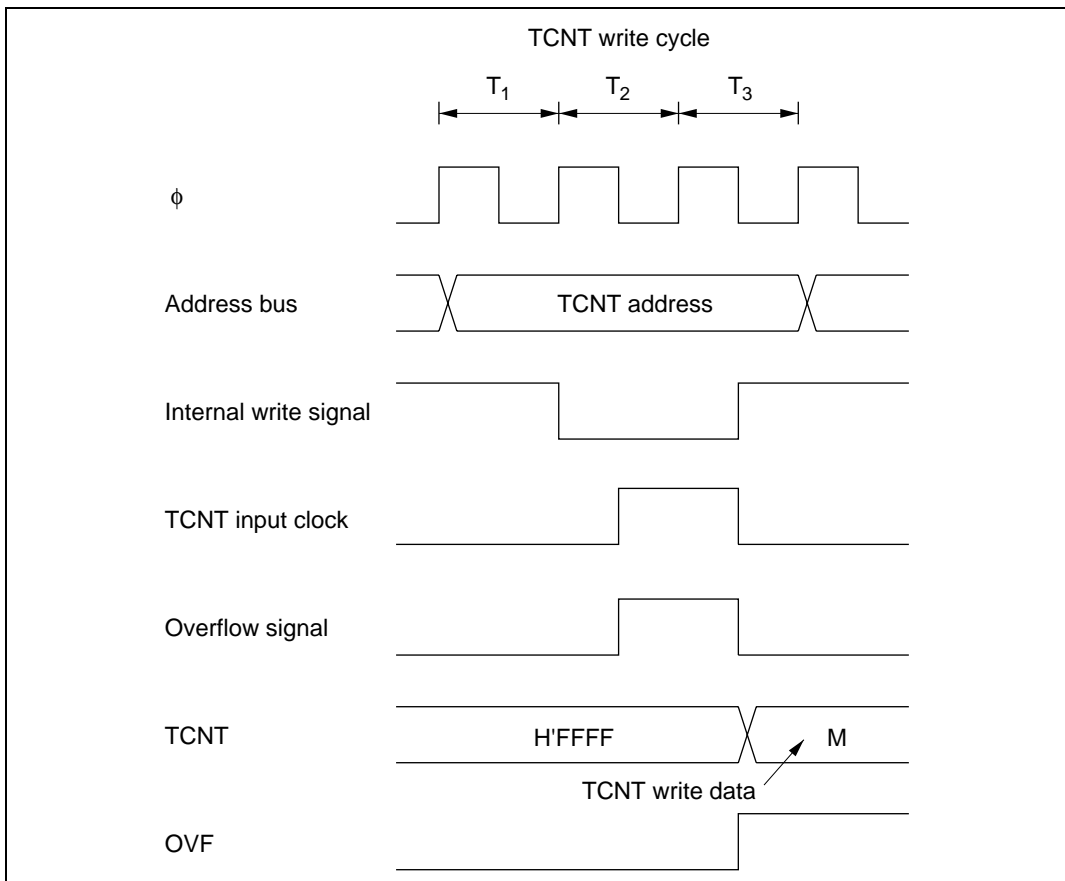

Figure 10.65 Contention between TCNT Write and Overflow

Contention between General Register Read and Input Capture

If an input capture signal occurs during the T_3 state of a general register read cycle, the value before input capture is read. See figure 10.66.

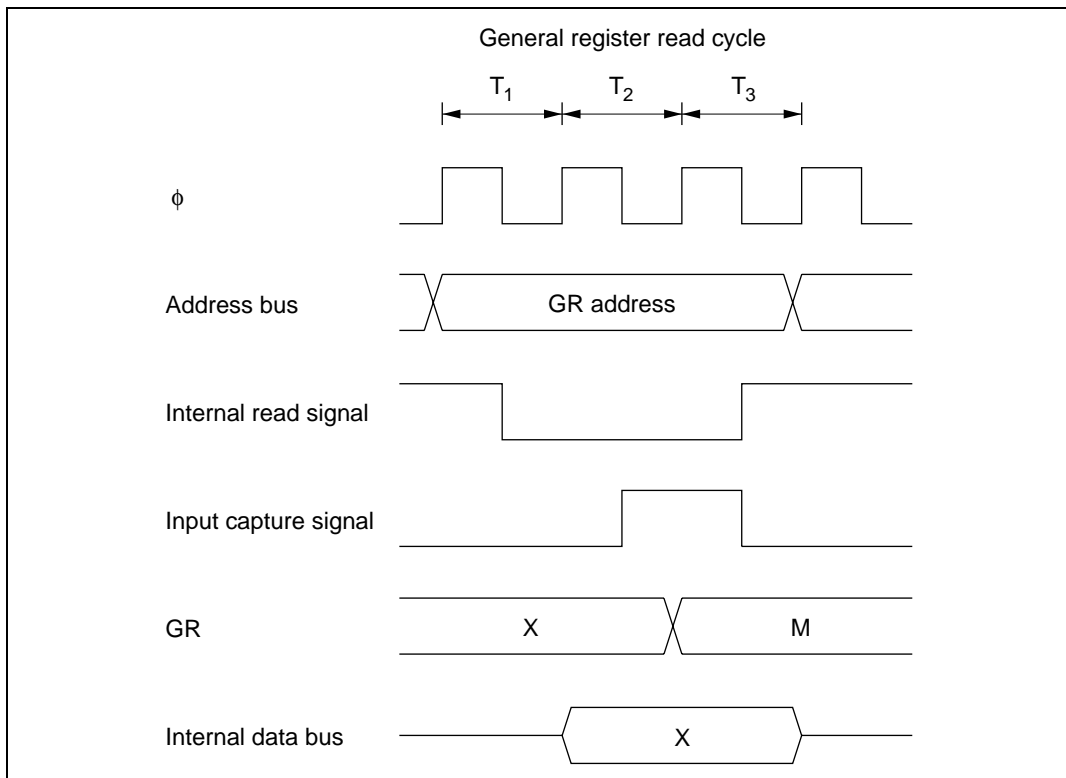

Figure 10.66 Contention between General Register Read and Input Capture

Contention between Counter Clearing by Input Capture and Counter Increment

If an input capture signal and counter increment signal occur simultaneously, the counter is cleared according to the input capture signal. The counter is not incremented by the increment signal. The value before the counter is cleared is transferred to the general register. See figure 10.67.

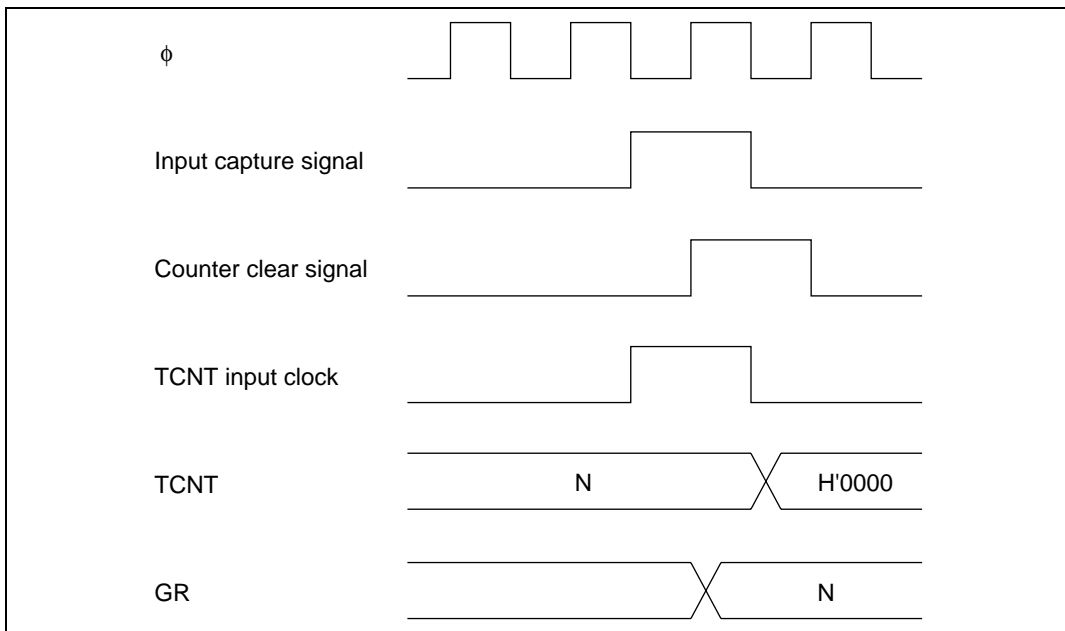

Figure 10.67 Contention between Counter Clearing by Input Capture and Counter Increment

Contention between General Register Write and Input Capture

If an input capture signal occurs in the T_3 state of a general register write cycle, input capture takes priority and the write to the general register is not performed. See figure 10.68.

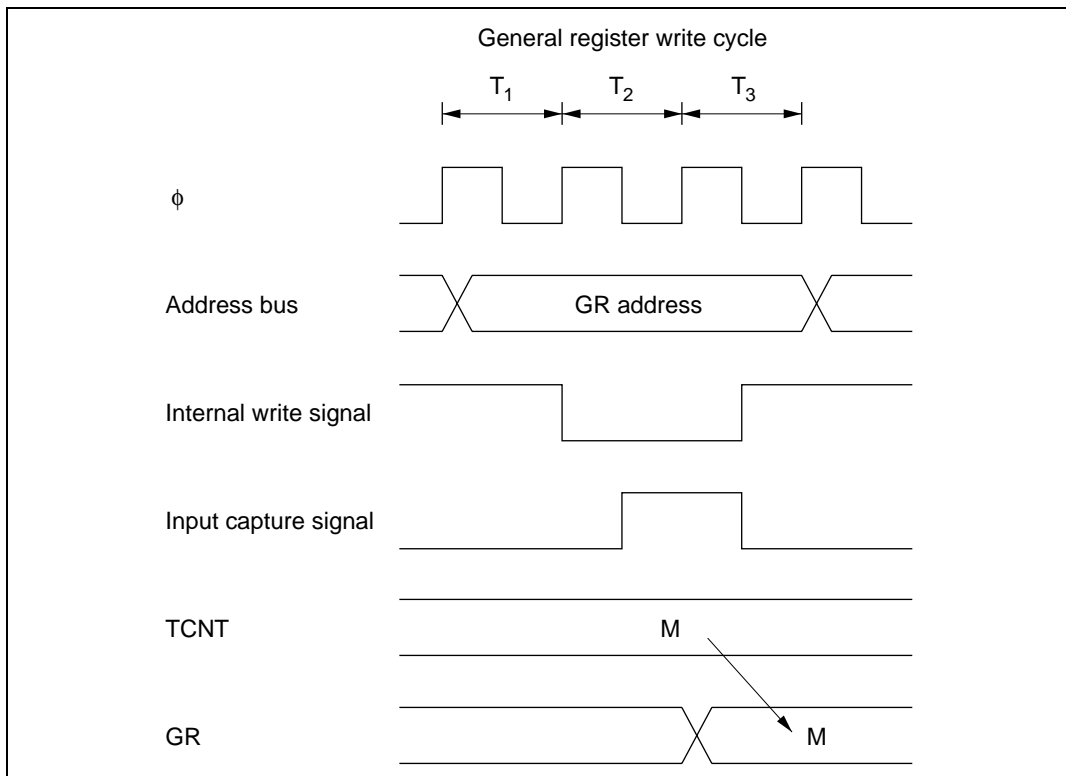

Figure 10.68 Contention between General Register Write and Input Capture

Note on Waveform Period Setting

When a counter is cleared by compare match, the counter is cleared in the last state at which the TCNT value matches the general register value, at the time when this value would normally be updated to the next count. The actual counter frequency is therefore given by the following formula:

$$f = \frac{\phi}{(N + 1)}$$

(f: counter frequency. ϕ : system clock frequency. N: value set in general register.)

Contention between Buffer Register Write and Input Capture

If a buffer register is used for input capture buffering and an input capture signal occurs in the T_3 state of a write cycle, input capture takes priority and the write to the buffer register is not performed. See figure 10.69.

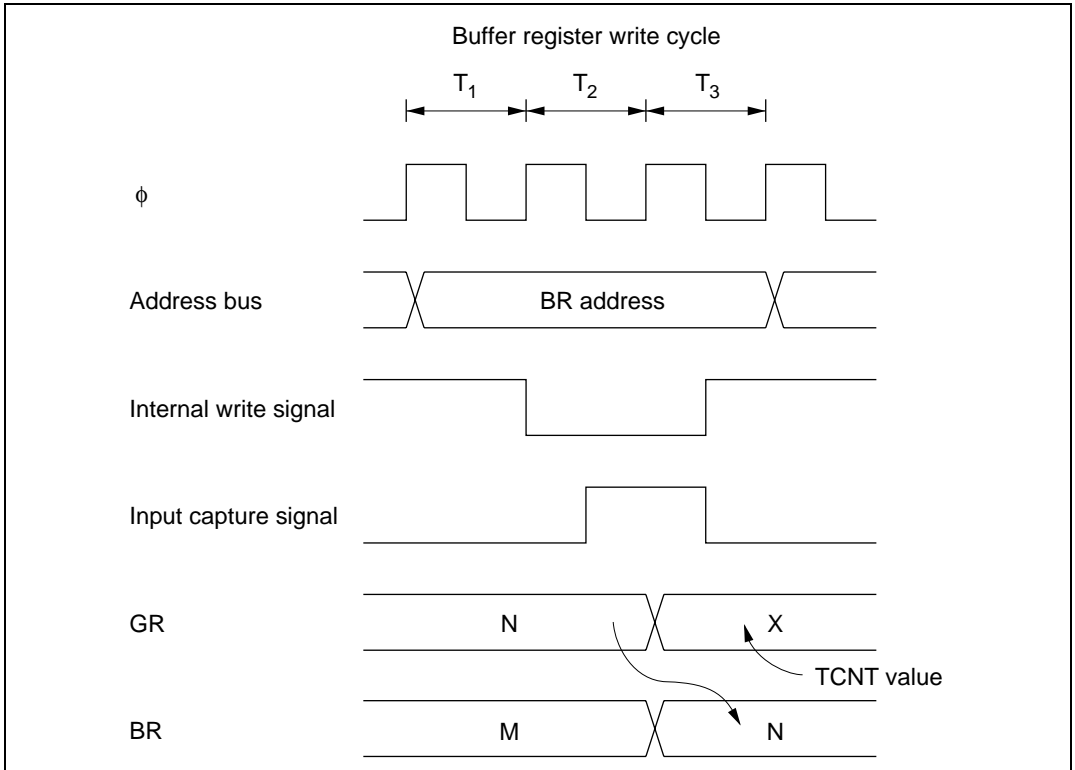

Figure 10.69 Contention between Buffer Register Write and Input Capture

Note on Synchronous Preset

When channels are synchronized, if a TCNT value is modified by byte write access, all 16 bits of all synchronized counters assume the same value as the counter that was addressed.

Example: When channels 2 and 3 are synchronized

- Byte write to channel 2 or byte write to channel 3

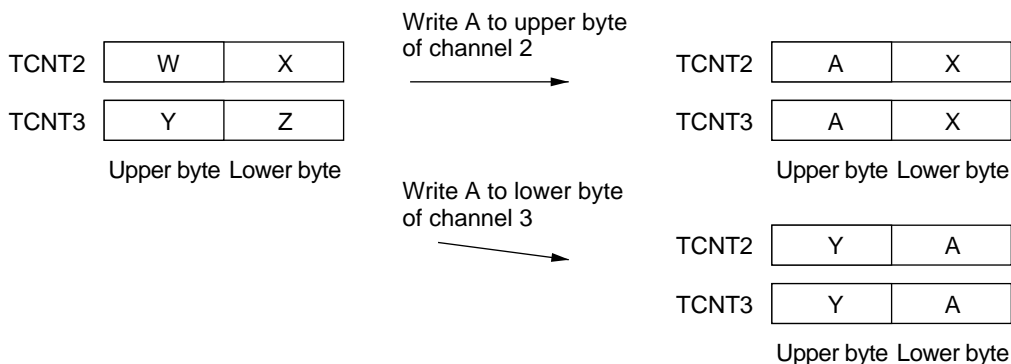

- Word write to channel 2 or word write to channel 3

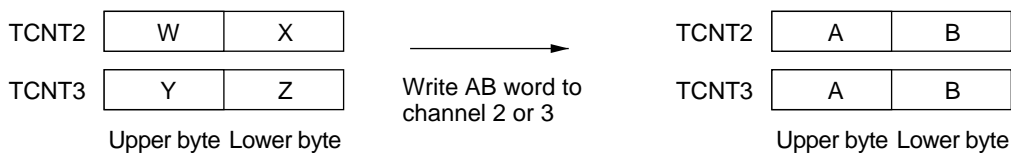

Note on Setup of Reset-Synchronized PWM Mode and Complementary PWM Mode

When setting bits CMD1 and CMD0 in TFCR, take the following precautions:

- Write to bits CMD1 and CMD0 only when TCNT3 and TCNT4 are stopped.
- Do not switch directly between reset-synchronized PWM mode and complementary PWM mode. First switch to normal mode (by clearing bit CMD1 to 0), then select reset-synchronized PWM mode or complementary PWM mode.

ITU Operating Modes

Table 10.11 (a) ITU Operating Modes (Channel 0)

Operating Mode	Register Settings														
	TSNC		TMDR			TFCR		TOCR		TOER		TIOR0		TCR0	
	Synchro- nization	MDF	FDIR	PWM	Comple- mentary PWM	Reset- Synchro- nized PWM	Buffer- ing	XTGD	Output Level Select	Master Enable	IOA	IOB	Clear Select	Clock Select	
Synchronous preset	SYNCO = 1	—	—	○	—	—	—	—	—	—	—	○	○	○	
PWM mode	○	—	—	PWM0 = 1	—	—	—	—	—	—	—	○*	○	○	
Output compare A	○	—	—	PWM0 = 0	—	—	—	—	—	—	IOA2 = 0 Other bits unrestricted	○	○	○	
Output compare B	○	—	—	○	—	—	—	—	—	—	○	IOB2 = 0 Other bits unrestricted	○	○	
Input capture A	○	—	—	PWM0 = 0	—	—	—	—	—	—	IOA2 = 1 Other bits unrestricted	○	○	○	
Input capture B	○	—	—	PWM0 = 0	—	—	—	—	—	—	○	IOB2 = 1 Other bits unrestricted	○	○	
Counter clearing	○	—	—	○	—	—	—	—	—	—	○	○	CCLR1 = 0 CCLR0 = 1	○	
	○	—	—	○	—	—	—	—	—	—	○	○	CCLR1 = 1 CCLR0 = 0	○	
Syn- chronous clear	SYNCO = 1	—	—	○	—	—	—	—	—	—	○	○	CCLR1 = 1 CCLR0 = 1	○	

Legend: ○ : Setting available (valid).

— : Setting does not affect this mode.

Note: * The input capture function cannot be used in PWM mode. If compare match A and compare match B occur simultaneously, the compare match signal is inhibited.

Table 10.11 (b) ITU Operating Modes (Channel 1)

Operating Mode	Register Settings													
	TSNC		TMDR		TFCR		TOCR		TOER	TIOR1		TCR1		
	Synchro- nization	MDF	FDIR	PWM	Comple- mentary PWM	Reset- Synchro- nized PWM	Buffer- ing	XTGD	Output Level Select	Master Enable	IOA	IOB	Clear Select	Clock Select
Synchronous preset	—	—	—	○	—	—	—	—	—	—	○	○	○	○
PWM mode	○	—	—	PWM1 = 1	—	—	—	—	—	—	—	○*1	○	○
Output compare A	○	—	—	PWM1 = 0	—	—	—	—	—	—	IOA2 = 0 Other bits unrestricted	○	○	○
Output compare B	○	—	—	○	—	—	—	—	—	—	○	IOB2 = 0 Other bits unrestricted	○	○
Input capture A	○	—	—	PWM1 = 0	—	—	—	○*2	—	—	IOA2 = 1 Other bits unrestricted	○	○	○
Input capture B	○	—	—	PWM1 = 0	—	—	—	—	—	—	○	IOB2 = 1 Other bits unrestricted	○	○
Counter clearing	○	—	—	○	—	—	—	—	—	—	○	○	CCLR1 = 0 CCLR0 = 1	○
	○	—	—	○	—	—	—	—	—	—	○	○	CCLR1 = 1 CCLR0 = 0	○
	○	—	—	○	—	—	—	—	—	—	○	○	CCLR1 = 1 CCLR0 = 1	○
Syn- chronous clear	○	—	—	○	—	—	—	—	—	—	○	○	CCLR1 = 1 CCLR0 = 1	○

Legend: ○ : Setting available (valid).

— : Setting does not affect this mode.

- Notes: 1. The input capture function cannot be used in PWM mode. If compare match A and compare match B occur simultaneously, the compare match signal is inhibited.
2. Valid only when channels 3 and 4 are operating in complementary PWM mode or reset-synchronized PWM mode.

Table 10.11 (c) ITU Operating Modes (Channel 2)

Operating Mode	Register Settings													
	TSSC		TMDR		TFCR			TOCR		TIOER		TCR2		
	Synchro- nization	MDF	FDIR	PWM	Comple- mentary PWM	Reset- Synchro- nized PWM	Buffer- ing	XTGD	Output Level Select	Master Enable	IOA	IOB	Clear Select	Clock Select
Synchronous preset	SYNC2 = 1	—	—	○	—	—	—	—	—	—	○	○	○	○
PWM mode	○	—	—	PWM2 = 1	—	—	—	—	—	—	—	○*	○	○
Output compare A	○	—	—	PWM2 = 0	—	—	—	—	—	—	IOA2 = 0 Other bits unrestricted	○	○	○
Output compare B	○	—	—	○	—	—	—	—	—	—	IOB2 = 0 Other bits unrestricted	○	○	○
Input capture A	○	—	—	PWM2 = 0	—	—	—	—	—	—	IOA2 = 1 Other bits unrestricted	○	○	○
Input capture B	○	—	—	PWM2 = 0	—	—	—	—	—	—	○	IOB2 = 1 Other bits unrestricted	○	○
Counter By compare match/input capture A	○	—	—	○	—	—	—	—	—	—	○	○	CCLR1 = 0 CCLR0 = 1	○
	○	—	—	○	—	—	—	—	—	—	○	○	CCLR1 = 1 CCLR0 = 0	○
	○	—	—	○	—	—	—	—	—	—	○	○	CCLR1 = 1 CCLR0 = 1	○
Syn- chronous clear	SYNC2 = 1	—	—	○	—	—	—	—	—	—	○	○	CCLR1 = 1 CCLR0 = 1	○
Phase counting mode	○	MDF = 1	○	○	—	—	—	—	—	—	○	○	○	—

Legend: ○: Setting available (valid).

—: Setting does not affect this mode.

Note: * The input capture function cannot be used in PWM mode. If compare match A and compare match B occur simultaneously, the compare match signal is inhibited.

Table 10.11 (d) ITU Operating Modes (Channel 3)

Operating Mode	Register Settings														
	TSNC			TMDR			TFCR			TOCR		TIOR3		TCR3	
	Synchro- nization	MDF	FDIR	PWM	Comple- mentary PWM	Reset- Synchro- nized PWM	Buffer- ing	XTGD	Output Level Select	Master Enable	IOA	IOB	Clear Select	Clock Select	
Synchronous preset	SYNC3 = 1	—	—	○	○ ^{*3}	○	○	—	—	○ ^{*1}	○	○	○	○	
PWM mode	○	—	—	PWM3 = 1	CMD1 = 0	CMD1 = 0	○	—	—	○	—	○ ^{*2}	○	○	
Output compare A	○	—	—	PWM3 = 0	CMD1 = 0	CMD1 = 0	○	—	—	○	IOA2 = 0 Other bits unrestricted	○	○	○	
Output compare B	○	—	—	○	CMD1 = 0	CMD1 = 0	○	—	—	○	IOB2 = 0 Other bits unrestricted	○	○	○	
Input capture A	○	—	—	PWM3 = 0	CMD1 = 0	CMD1 = 0	○	—	—	EA3 ignored Other bits unrestricted	IOA2 = 1 Other bits unrestricted	○	○	○	
Input capture B	○	—	—	PWM3 = 0	CMD1 = 0	CMD1 = 0	○	—	—	EB3 ignored Other bits unrestricted	IOA2 = 1 Other bits unrestricted	○	○	○	
Counter clearing match/input capture A	○	—	—	○	Illegal setting: CMD1 = 1 CMD0 = 0	○ ^{*4}	○	—	—	○ ^{*1}	○	○	CCLR1 = 0 CCLR0 = 1	○	
By compare match/input capture B	○	—	—	○	CMD1 = 0	CMD1 = 0	○	—	—	○ ^{*1}	○	○	CCLR1 = 1 CCLR0 = 0	○	
Syn- chronous clear	SYNC3 = 1	—	—	○	Illegal setting: CMD1 = 1 CMD0 = 0	○	○	—	—	○ ^{*1}	○	○	CCLR1 = 1 CCLR0 = 1	○	
Complementary PWM mode	○ ^{*3}	—	—	—	CMD1 = 1 CMD0 = 0	CMD1 = 1 CMD0 = 0	○	○ ^{*6}	○	○	—	—	CCLR1 = 0 CCLR0 = 0	○ ^{*6}	
Reset-synchronized PWM mode	○	—	—	—	CMD1 = 1 CMD0 = 1	CMD1 = 1 CMD0 = 1	○	○ ^{*6}	○	○	—	—	CCLR1 = 0 CCLR0 = 1	○	
Buffering (BRA)	○	—	—	○	○	○	○	—	—	○ ^{*1}	○	○	○	○	
Buffering (BRB)	○	—	—	○	○	○	○	—	—	○ ^{*1}	○	○	○	○	

Legend: ○ : Setting available (valid).

— : Setting does not affect this mode.

- Notes:
1. Master enable bit settings are valid only during waveform output.
 2. The input capture function cannot be used in PWM mode. If compare match A and compare match B occur simultaneously, the compare match signal is inhibited.
 3. Do not set both channels 3 and 4 for synchronous operation when complementary PWM mode is selected.
 4. The counter cannot be cleared by input capture A when reset-synchronized PWM mode is selected.
 5. In complementary PWM mode, select the same clock source for channels 3 and 4.
 6. Use the input capture A function in channel 1.

Table 10.11 (e) ITU Operating Modes (Channel 4)

Operating Mode	Register Settings													
	TSNC		TMDR		TFCR		TOCR		TOER		TIOR4		TCR4	
	Synchro- nization	MDF	FDIR	PWM	Comple- mentary PWM	Reset- Synchro- nized PWM	Buffer- ing	XTGD	Output Level Select	Master Enable	IOA	IOB	Clear Select	Clock Select
Synchronous preset	SYNC4 = 1	—	—	○	○*3	—	○	—	—	○*1	○	○	○	○
PWM mode	○	—	—	PWM4 = 1	CMD1 = 0	CMD1 = 0	○	—	—	○	—	○*2	○	○
Output compare A	○	—	—	PWM4 = 0	CMD1 = 0	CMD1 = 0	○	—	—	○	IOA2 = 0 Other bits unrestricted	○	○	○
Output compare B	○	—	—	○	CMD1 = 0	CMD1 = 0	○	—	—	○	IOB2 = 0 Other bits unrestricted	○	○	○
Input capture A	○	—	—	PWM4 = 0	CMD1 = 0	CMD1 = 0	○	—	—	EA4 ignored Other bits unrestricted	IOA2 = 1 Other bits unrestricted	○	○	○
Input capture B	○	—	—	PWM4 = 0	CMD1 = 0	CMD1 = 0	○	—	—	EB4 ignored Other bits unrestricted	IOA2 = 1 Other bits unrestricted	○	○	○
Counter By compare clearing match/input capture A	○	—	—	○	Illegal setting: CMD1 = 1 CMD0 = 0	○*4	○	—	—	○*1	○	○	CCLR1 = 0 CCLR0 = 1	○
	○	—	—	○	Illegal setting: CMD1 = 1 CMD0 = 0	○*4	○	—	—	○*1	○	○	CCLR1 = 1 CCLR0 = 0	○
By compare match/input capture B	○	—	—	○	Illegal setting: CMD1 = 1 CMD0 = 0	○*4	○	—	—	○*1	○	○	CCLR1 = 1 CCLR0 = 0	○
	○	—	—	○	Illegal setting: CMD1 = 1 CMD0 = 0	○*4	○	—	—	○*1	○	○	CCLR1 = 1 CCLR0 = 1	○
Syn- chronous clear	SYNC4 = 1	—	—	○	Illegal setting: CMD1 = 1 CMD0 = 0	○*4	○	—	—	○*1	○	○	CCLR1 = 1 CCLR0 = 1	○
Complementary PWM mode	○*3	—	—	—	CMD1 = 1 CMD0 = 0	CMD1 = 1 CMD0 = 0	○	○	○	○	—	—	CCLR1 = 0 CCLR0 = 0	○*5
	○	—	—	—	CMD1 = 1 CMD0 = 0	CMD1 = 1 CMD0 = 0	○	○	○	○	—	—	○*6	○*6
Reset-synchronized PWM mode	○	—	—	—	CMD1 = 1 CMD0 = 0	CMD1 = 1 CMD0 = 0	○	○	○	○	○	○	○	○
Buffering (BRA)	○	—	—	○	○	○	BFA4 = 1 Other bits unrestricted	—	—	○*1	○	○	○	○
Buffering (BRB)	○	—	—	○	○	○	BFA4 = 1 Other bits unrestricted	—	—	○*1	○	○	○	○

Legend: ○ : Setting available (valid).

— : Setting does not affect this mode.

- Notes:
1. Master enable bit settings are valid only during waveform output.
 2. The input capture function cannot be used in PWM mode. If compare match A and compare match B occur simultaneously, the compare match signal is inhibited.
 3. Do not set both channels 3 and 4 for synchronous operation when complementary PWM mode is selected.
 4. When reset-synchronized PWM mode is selected, TCNT4 operates independently and the counter clearing function is available. Waveform output is not affected.
 5. In complementary PWM mode, select the same clock source for channels 3 and 4.
 6. TCR4 settings are valid in reset-synchronized PWM mode, but TCNT4 operates independently, without affecting waveform output.

Section 11 Programmable Timing Pattern Controller

11.1 Overview

The H8/3048B Group has a built-in programmable timing pattern controller (TPC) that provides pulse outputs by using the 16-bit integrated timer unit (ITU) as a time base. The TPC pulse outputs are divided into 4-bit groups (group 3 to group 0) that can operate simultaneously and independently.

11.1.1 Features

TPC features are listed below.

- 16-bit output data
Maximum 16-bit data can be output. TPC output can be enabled on a bit-by-bit basis.
- Four output groups
Output trigger signals can be selected in 4-bit groups to provide up to four different 4-bit outputs.
- Selectable output trigger signals
Output trigger signals can be selected for each group from the compare-match signals of four ITU channels.
- Non-overlap mode
A non-overlap margin can be provided between pulse outputs.
- Can operate together with the DMA controller (DMAC)
The compare-match signals selected as trigger signals can activate the DMAC for sequential output of data without CPU intervention.

11.1.2 Block Diagram

Figure 11.1 shows a block diagram of the TPC.

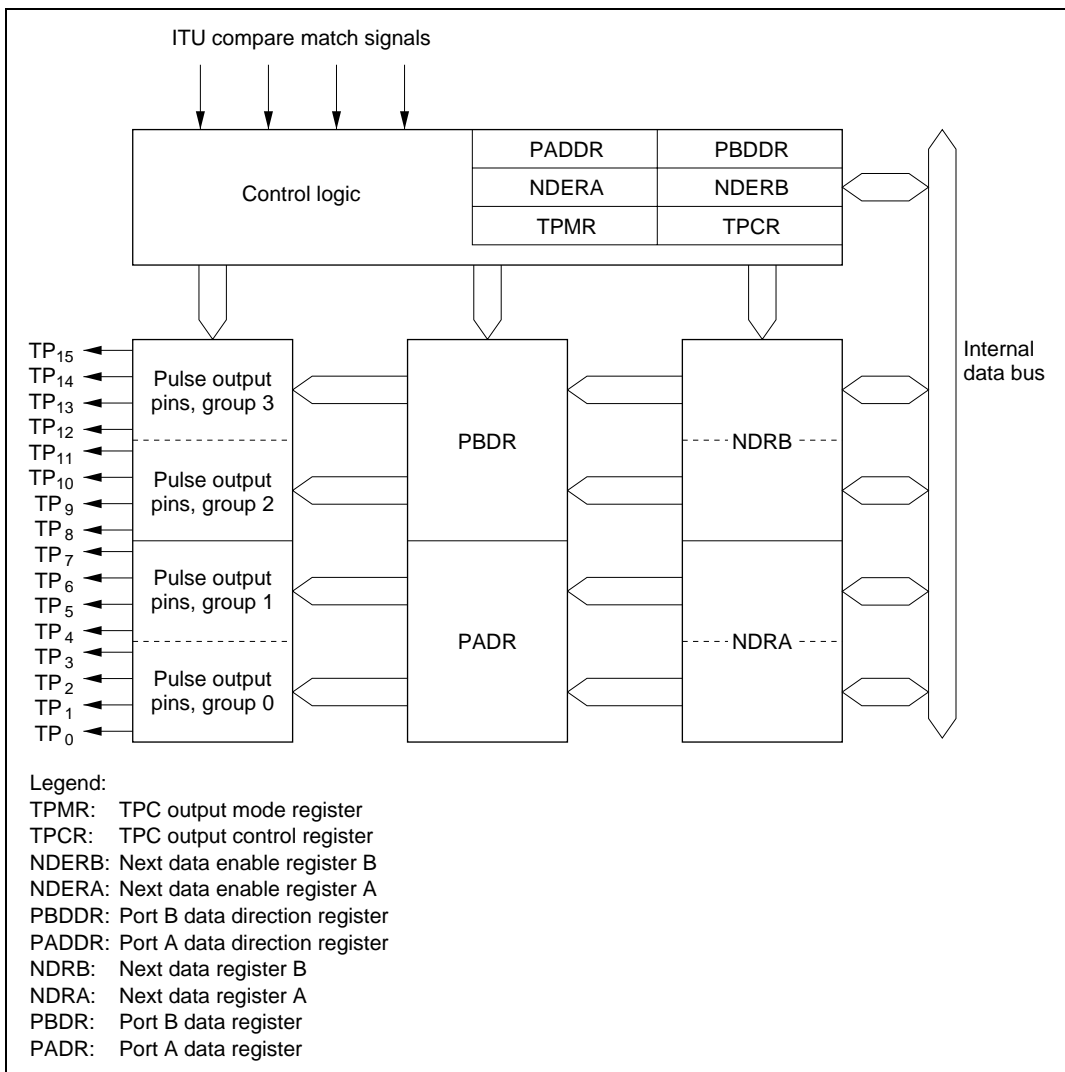

Figure 11.1 TPC Block Diagram

11.1.3 TPC Pins

Table 11.1 summarizes the TPC output pins.

Table 11.1 TPC Pins

Name	Symbol	I/O	Function
TPC output 0	TP ₀	Output	Group 0 pulse output
TPC output 1	TP ₁	Output	
TPC output 2	TP ₂	Output	
TPC output 3	TP ₃	Output	Group 1 pulse output
TPC output 4	TP ₄	Output	
TPC output 5	TP ₅	Output	
TPC output 6	TP ₆	Output	Group 2 pulse output
TPC output 7	TP ₇	Output	
TPC output 8	TP ₈	Output	
TPC output 9	TP ₉	Output	Group 3 pulse output
TPC output 10	TP ₁₀	Output	
TPC output 11	TP ₁₁	Output	
TPC output 12	TP ₁₂	Output	Group 3 pulse output
TPC output 13	TP ₁₃	Output	
TPC output 14	TP ₁₄	Output	
TPC output 15	TP ₁₅	Output	

11.1.4 Registers

Table 11.2 summarizes the TPC registers.

Table 11.2 TPC Registers

Address ^{*1}	Name	Abbreviation	R/W	Initial Value
H'FFD1	Port A data direction register	PADDR	W	H'00
H'FFD3	Port A data register	PADR	R/(W) ^{*2}	H'00
H'FFD4	Port B data direction register	PBDDR	W	H'00
H'FFD6	Port B data register	PBDR	R/(W) ^{*2}	H'00
H'FFA0	TPC output mode register	TPMR	R/W	H'F0
H'FFA1	TPC output control register	TPCR	R/W	H'FF
H'FFA2	Next data enable register B	NDERB	R/W	H'00
H'FFA3	Next data enable register A	NDERA	R/W	H'00
H'FFA5/ H'FFA7 ^{*3}	Next data register A	NDRA	R/W	H'00
H'FFA4 H'FFA6 ^{*3}	Next data register B	NDRB	R/W	H'00

- Notes:
1. Lower 16 bits of the address.
 2. Bits used for TPC output cannot be written.
 3. The NDRA address is H'FFA5 when the same output trigger is selected for TPC output groups 0 and 1 by settings in TPCR. When the output triggers are different, the NDRA address is H'FFA7 for group 0 and H'FFA5 for group 1. Similarly, the address of NDRB is H'FFA4 when the same output trigger is selected for TPC output groups 2 and 3 by settings in TPCR. When the output triggers are different, the NDRB address is H'FFA6 for group 2 and H'FFA4 for group 3.

11.2 Register Descriptions

11.2.1 Port A Data Direction Register (PADDR)

PADDR is an 8-bit write-only register that selects input or output for each pin in port A.

Bit	7	6	5	4	3	2	1	0
	PA ₇ DDR	PA ₆ DDR	PA ₅ DDR	PA ₄ DDR	PA ₃ DDR	PA ₂ DDR	PA ₁ DDR	PA ₀ DDR
Initial value	0	0	0	0	0	0	0	0
Read/Write	W	W	W	W	W	W	W	W

Port A data direction 7 to 0

These bits select input or output for port A pins

Port A is multiplexed with pins TP₇ to TP₀. Bits corresponding to pins used for TPC output must be set to 1. For further information about PADDR, see section 9.11, Port A.

11.2.2 Port A Data Register (PADR)

PADR is an 8-bit readable/writable register that stores TPC output data for groups 0 and 1, when these TPC output groups are used.

Bit	7	6	5	4	3	2	1	0
	PA ₇	PA ₆	PA ₅	PA ₄	PA ₃	PA ₂	PA ₁	PA ₀
Initial value	0	0	0	0	0	0	0	0
Read/Write	R/(W)*	R/(W)*	R/(W)*	R/(W)*	R/(W)*	R/(W)*	R/(W)*	R/(W)*

Port A data 7 to 0

These bits store output data for TPC output groups 0 and 1

Note: * Bits selected for TPC output by NDERA settings become read-only bits.

For further information about PADR, see section 9.11, Port A.

11.2.3 Port B Data Direction Register (PBDDR)

PBDDR is an 8-bit write-only register that selects input or output for each pin in port B.

Bit	7	6	5	4	3	2	1	0
	PB ₇ DDR	PB ₆ DDR	PB ₅ DDR	PB ₄ DDR	PB ₃ DDR	PB ₂ DDR	PB ₁ DDR	PB ₀ DDR
Initial value	0	0	0	0	0	0	0	0
Read/Write	W	W	W	W	W	W	W	W

Port B data direction 7 to 0

These bits select input or output for port B pins

Port B is multiplexed with pins TP₁₅ to TP₈. Bits corresponding to pins used for TPC output must be set to 1. For further information about PBDDR, see section 9.12, Port B.

11.2.4 Port B Data Register (PBDR)

PBDR is an 8-bit readable/writable register that stores TPC output data for groups 2 and 3, when these TPC output groups are used.

Bit	7	6	5	4	3	2	1	0
	PB ₇	PB ₆	PB ₅	PB ₄	PB ₃	PB ₂	PB ₁	PB ₀
Initial value	0	0	0	0	0	0	0	0
Read/Write	R/(W)*	R/(W)*	R/(W)*	R/(W)*	R/(W)*	R/(W)*	R/(W)*	R/(W)*

Port B data 7 to 0

These bits store output data for TPC output groups 2 and 3

Note: * Bits selected for TPC output by NDERB settings become read-only bits.

For further information about PBDR, see section 9.12, Port B.

11.2.5 Next Data Register A (NDRA)

NDRA is an 8-bit readable/writable register that stores the next output data for TPC output groups 1 and 0 (pins TP₇ to TP₀). During TPC output, when an ITU compare match event specified in TPCR occurs, NDRA contents are transferred to the corresponding bits in PADR. The address of NDRA differs depending on whether TPC output groups 0 and 1 have the same output trigger or different output triggers.

NDRA is initialized to H'00 by a reset and in hardware standby mode. It is not initialized in software standby mode.

Same Trigger for TPC Output Groups 0 and 1

If TPC output groups 0 and 1 are triggered by the same compare match event, the NDRA address is H'FFA5. The upper 4 bits belong to group 1 and the lower 4 bits to group 0. Address H'FFA7 consists entirely of reserved bits that cannot be modified and are always read as 1.

Address H'FFA5

Bit	7	6	5	4	3	2	1	0
	NDR7	NDR6	NDR5	NDR4	NDR3	NDR2	NDR1	NDR0
Initial value	0	0	0	0	0	0	0	0
Read/Write	R/W	R/W	R/W	R/W	R/W	R/W	R/W	R/W

Next data 7 to 4	Next data 3 to 0
These bits store the next output data for TPC output group 1	These bits store the next output data for TPC output group 0

Address H'FFA7

Bit	7	6	5	4	3	2	1	0
	—	—	—	—	—	—	—	—
Initial value	1	1	1	1	1	1	1	1
Read/Write	—	—	—	—	—	—	—	—

Reserved bits

Different Triggers for TPC Output Groups 0 and 1

If TPC output groups 0 and 1 are triggered by different compare match events, the address of the upper 4 bits of NDRA (group 1) is H'FFA5 and the address of the lower 4 bits (group 0) is H'FFA7. Bits 3 to 0 of address H'FFA5 and bits 7 to 4 of address H'FFA7 are reserved bits that cannot be modified and are always read as 1.

Address H'FFA5

Bit	7	6	5	4	3	2	1	0
	NDR7	NDR6	NDR5	NDR4	—	—	—	—
Initial value	0	0	0	0	1	1	1	1
Read/Write	R/W	R/W	R/W	R/W	—	—	—	—

Next data 7 to 4
Reserved bits

These bits store the next output data for TPC output group 1

Address H'FFA7

Bit	7	6	5	4	3	2	1	0
	—	—	—	—	NDR3	NDR2	NDR1	NDR0
Initial value	1	1	1	1	0	0	0	0
Read/Write	—	—	—	—	R/W	R/W	R/W	R/W

Reserved bits
Next data 3 to 0

These bits store the next output data for TPC output group 0

11.2.6 Next Data Register B (NDRB)

NDRB is an 8-bit readable/writable register that stores the next output data for TPC output groups 3 and 2 (pins TP₁₅ to TP₈). During TPC output, when an ITU compare match event specified in TPCR occurs, NDRB contents are transferred to the corresponding bits in PBDR. The address of NDRB differs depending on whether TPC output groups 2 and 3 have the same output trigger or different output triggers.

NDRB is initialized to H'00 by a reset and in hardware standby mode. It is not initialized in software standby mode.

Same Trigger for TPC Output Groups 2 and 3

If TPC output groups 2 and 3 are triggered by the same compare match event, the NDRB address is H'FFA4. The upper 4 bits belong to group 3 and the lower 4 bits to group 2. Address H'FFA6 consists entirely of reserved bits that cannot be modified and are always read as 1.

Address H'FFA4

Bit	7	6	5	4	3	2	1	0
	NDR15	NDR14	NDR13	NDR12	NDR11	NDR10	NDR9	NDR8
Initial value	0	0	0	0	0	0	0	0
Read/Write	R/W	R/W	R/W	R/W	R/W	R/W	R/W	R/W

Next data 15 to 12	Next data 11 to 8
These bits store the next output data for TPC output group 3	These bits store the next output data for TPC output group 2

Address H'FFA6

Bit	7	6	5	4	3	2	1	0
	—	—	—	—	—	—	—	—
Initial value	1	1	1	1	1	1	1	1
Read/Write	—	—	—	—	—	—	—	—

Reserved bits

Different Triggers for TPC Output Groups 2 and 3

If TPC output groups 2 and 3 are triggered by different compare match events, the address of the upper 4 bits of NDRB (group 3) is H'FFA4 and the address of the lower 4 bits (group 2) is H'FFA6. Bits 3 to 0 of address H'FFA4 and bits 7 to 4 of address H'FFA6 are reserved bits that cannot be modified and are always read as 1.

Address H'FFA4

Bit	7	6	5	4	3	2	1	0
	NDR15	NDR14	NDR13	NDR12	—	—	—	—
Initial value	0	0	0	0	1	1	1	1
Read/Write	R/W	R/W	R/W	R/W	—	—	—	—

Next data 15 to 12
Reserved bits

These bits store the next output data for TPC output group 3

Address H'FFA6

Bit	7	6	5	4	3	2	1	0
	—	—	—	—	NDR11	NDR10	NDR9	NDR8
Initial value	1	1	1	1	0	0	0	0
Read/Write	—	—	—	—	R/W	R/W	R/W	R/W

Reserved bits
Next data 11 to 8

These bits store the next output data for TPC output group 2

11.2.7 Next Data Enable Register A (NDERA)

NDERA is an 8-bit readable/writable register that enables or disables TPC output groups 1 and 0 (TP₇ to TP₀) on a bit-by-bit basis.

Bit	7	6	5	4	3	2	1	0
	NDER7	NDER6	NDER5	NDER4	NDER3	NDER2	NDER1	NDER0
Initial value	0	0	0	0	0	0	0	0
Read/Write	R/W	R/W	R/W	R/W	R/W	R/W	R/W	R/W

Next data enable 7 to 0

These bits enable or disable
TPC output groups 1 and 0

If a bit is enabled for TPC output by NDERA, then when the ITU compare match event selected in the TPC output control register (TPCR) occurs, the NDRA value is automatically transferred to the corresponding PADR bit, updating the output value. If TPC output is disabled, the bit value is not transferred from NDRA to PADR and the output value does not change.

NDERA is initialized to H'00 by a reset and in hardware standby mode. It is not initialized in software standby mode.

Bits 7 to 0—Next Data Enable 7 to 0 (NDER7 to NDER0): These bits enable or disable TPC output groups 1 and 0 (TP₇ to TP₀) on a bit-by-bit basis.

Bits 7 to 0:

NDER7 to NDER0	Description
0	TPC outputs TP ₇ to TP ₀ are disabled (NDR7 to NDR0 are not transferred to PA ₇ to PA ₀) (Initial value)
1	TPC outputs TP ₇ to TP ₀ are enabled (NDR7 to NDR0 are transferred to PA ₇ to PA ₀)

11.2.8 Next Data Enable Register B (NDERB)

NDERB is an 8-bit readable/writable register that enables or disables TPC output groups 3 and 2 (TP₁₅ to TP₈) on a bit-by-bit basis.

Bit	7	6	5	4	3	2	1	0
	NDER15	NDER14	NDER13	NDER12	NDER11	NDER10	NDER9	NDER8
Initial value	0	0	0	0	0	0	0	0
Read/Write	R/W	R/W	R/W	R/W	R/W	R/W	R/W	R/W

Next data enable 15 to 8

These bits enable or disable
TPC output groups 3 and 2

If a bit is enabled for TPC output by NDERB, then when the ITU compare match event selected in the TPC output control register (TPCR) occurs, the NDRB value is automatically transferred to the corresponding PBDR bit, updating the output value. If TPC output is disabled, the bit value is not transferred from NDRB to PBDR and the output value does not change.

NDERB is initialized to H'00 by a reset and in hardware standby mode. It is not initialized in software standby mode.

Bits 7 to 0—Next Data Enable 15 to 8 (NDER15 to NDER8): These bits enable or disable TPC output groups 3 and 2 (TP₁₅ to TP₈) on a bit-by-bit basis.

Bits 7 to 0:

NDER15 to NDER8	Description
0	TPC outputs TP ₁₅ to TP ₈ are disabled (NDR15 to NDR8 are not transferred to PB ₇ to PB ₀) (Initial value)
1	TPC outputs TP ₁₅ to TP ₈ are enabled (NDR15 to NDR8 are transferred to PB ₇ to PB ₀)

11.2.9 TPC Output Control Register (TPCR)

TPCR is an 8-bit readable/writable register that selects output trigger signals for TPC outputs on a group-by-group basis.

Bit	7	6	5	4	3	2	1	0
	G3CMS1	G3CMS0	G2CMS1	G2CMS0	G1CMS1	G1CMS0	G0CMS1	G0CMS0
Initial value	1	1	1	1	1	1	1	1
Read/Write	R/W	R/W	R/W	R/W	R/W	R/W	R/W	R/W

<p>Group 3 compare match select 1 and 0 These bits select the compare match event that triggers TPC output group 3 (TP₁₅ to TP₁₂)</p>	<p>Group 2 compare match select 1 and 0 These bits select the compare match event that triggers TPC output group 2 (TP₁₁ to TP₈)</p>	<p>Group 1 compare match select 1 and 0 These bits select the compare match event that triggers TPC output group 1 (TP₇ to TP₄)</p>	<p>Group 0 compare match select 1 and 0 These bits select the compare match event that triggers TPC output group 0 (TP₃ to TP₀)</p>
--	---	--	--

TPCR is initialized to H'FF by a reset and in hardware standby mode. It is not initialized in software standby mode.

Bits 7 and 6—Group 3 Compare Match Select 1 and 0 (G3CMS1, G3CMS0): These bits select the compare match event that triggers TPC output group 3 (TP₁₅ to TP₁₂).

Bit 7: G3CMS1	Bit 6: G3CMS0	Description
0	0	TPC output group 3 (TP ₁₅ to TP ₁₂) is triggered by compare match in ITU channel 0
	1	TPC output group 3 (TP ₁₅ to TP ₁₂) is triggered by compare match in ITU channel 1
1	0	TPC output group 3 (TP ₁₅ to TP ₁₂) is triggered by compare match in ITU channel 2
	1	TPC output group 3 (TP ₁₅ to TP ₁₂) is triggered by compare match in ITU channel 3 (Initial value)

Bits 5 and 4—Group 2 Compare Match Select 1 and 0 (G2CMS1, G2CMS0): These bits select the compare match event that triggers TPC output group 2 (TP₁₁ to TP₈).

Bit 5: G2CMS1	Bit 4: G2CMS0	Description
0	0	TPC output group 2 (TP ₁₁ to TP ₈) is triggered by compare match in ITU channel 0
	1	TPC output group 2 (TP ₁₁ to TP ₈) is triggered by compare match in ITU channel 1
1	0	TPC output group 2 (TP ₁₁ to TP ₈) is triggered by compare match in ITU channel 2
	1	TPC output group 2 (TP ₁₁ to TP ₈) is triggered by compare match in ITU channel 3 (Initial value)

Bits 3 and 2—Group 1 Compare Match Select 1 and 0 (G1CMS1, G1CMS0): These bits select the compare match event that triggers TPC output group 1 (TP₇ to TP₄).

Bit 3: G1CMS1	Bit 2: G1CMS0	Description
0	0	TPC output group 1 (TP ₇ to TP ₄) is triggered by compare match in ITU channel 0
	1	TPC output group 1 (TP ₇ to TP ₄) is triggered by compare match in ITU channel 1
1	0	TPC output group 1 (TP ₇ to TP ₄) is triggered by compare match in ITU channel 2
	1	TPC output group 1 (TP ₇ to TP ₄) is triggered by compare match in ITU channel 3 (Initial value)

Bits 1 and 0—Group 0 Compare Match Select 1 and 0 (G0CMS1, G0CMS0): These bits select the compare match event that triggers TPC output group 0 (TP₃ to TP₀).

Bit 1: G0CMS1	Bit 0: G0CMS0	Description
0	0	TPC output group 0 (TP ₃ to TP ₀) is triggered by compare match in ITU channel 0
	1	TPC output group 0 (TP ₃ to TP ₀) is triggered by compare match in ITU channel 1
1	0	TPC output group 0 (TP ₃ to TP ₀) is triggered by compare match in ITU channel 2
	1	TPC output group 0 (TP ₃ to TP ₀) is triggered by compare match in ITU channel 3 (Initial value)

11.2.10 TPC Output Mode Register (TPMR)

TPMR is an 8-bit readable/writable register that selects normal or non-overlapping TPC output for each group.

Bit	7	6	5	4	3	2	1	0
	—	—	—	—	G3NOV	G2NOV	G1NOV	G0NOV
Initial value	1	1	1	1	0	0	0	0
Read/Write	—	—	—	—	R/W	R/W	R/W	R/W

Reserved bits

Group 3 non-overlap
Selects non-overlapping TPC output for group 3 (TP₁₅ to TP₁₂)

Group 2 non-overlap
Selects non-overlapping TPC output for group 2 (TP₁₁ to TP₈)

Group 1 non-overlap
Selects non-overlapping TPC output for group 1 (TP₇ to TP₄)

Group 0 non-overlap
Selects non-overlapping TPC output for group 0 (TP₃ to TP₀)

The output trigger period of a non-overlapping TPC output waveform is set in general register B (GRB) in the ITU channel selected for output triggering. The non-overlap margin is set in general register A (GRA). The output values change at compare match A and B. For details see section 11.3.4, Non-Overlapping TPC Output.

TPMR is initialized to H'F0 by a reset and in hardware standby mode. It is not initialized in software standby mode.

Bits 7 to 4—Reserved: Read-only bits, always read as 1.

Bit 3—Group 3 Non-Overlap (G3NOV): Selects normal or non-overlapping TPC output for group 3 (TP₁₅ to TP₁₂).

Bit 3: G3NOV	Description
0	Normal TPC output in group 3 (output values change at compare match A in the selected ITU channel) (Initial value)
1	Non-overlapping TPC output in group 3 (independent 1 and 0 output at compare match A and B in the selected ITU channel)

Bit 2—Group 2 Non-Overlap (G2NOV): Selects normal or non-overlapping TPC output for group 2 (TP₁₁ to TP₈).

Bit 2: G2NOV	Description
0	Normal TPC output in group 2 (output values change at compare match A in the selected ITU channel) (Initial value)
1	Non-overlapping TPC output in group 2 (independent 1 and 0 output at compare match A and B in the selected ITU channel)

Bit 1—Group 1 Non-Overlap (G1NOV): Selects normal or non-overlapping TPC output for group 1 (TP₇ to TP₄).

Bit 1: G1NOV	Description
0	Normal TPC output in group 1 (output values change at compare match A in the selected ITU channel) (Initial value)
1	Non-overlapping TPC output in group 1 (independent 1 and 0 output at compare match A and B in the selected ITU channel)

Bit 0—Group 0 Non-Overlap (G0NOV): Selects normal or non-overlapping TPC output for group 0 (TP₃ to TP₀).

Bit 0: G0NOV	Description
0	Normal TPC output in group 0 (output values change at compare match A in the selected ITU channel) (Initial value)
1	Non-overlapping TPC output in group 0 (independent 1 and 0 output at compare match A and B in the selected ITU channel)

11.3 Operation

11.3.1 Overview

When corresponding bits in PADDR or PBDDR and NDERA or NDERB are set to 1, TPC output is enabled. The TPC output initially consists of the corresponding PADDR or PBDDR contents. When a compare-match event selected in TPCR occurs, the corresponding NDRA or NDRB bit contents are transferred to PADDR or PBDDR to update the output values.

Figure 11.2 illustrates the TPC output operation. Table 11.3 summarizes the TPC operating conditions.

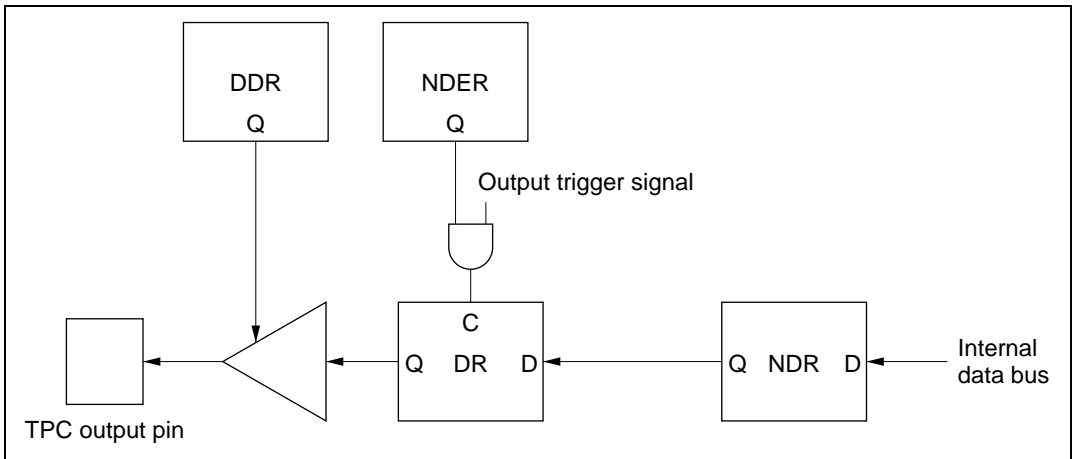

Figure 11.2 TPC Output Operation

Table 11.3 TPC Operating Conditions

NDR	DDR	Pin Function
0	0	Generic input port
	1	Generic output port
1	0	Generic input port (but the DR bit is a read-only bit, and when compare match occurs, the NDR bit value is transferred to the DR bit)
	1	TPC pulse output

Sequential output of up to 16-bit patterns is possible by writing new output data to NDRA and NDRB before the next compare match. For information on non-overlapping operation, see section 11.3.4, Non-Overlapping TPC Output.

11.3.2 Output Timing

If TPC output is enabled, NDRA/NDRB contents are transferred to PADR/PBDR and output when the selected compare match event occurs. Figure 11.3 shows the timing of these operations for the case of normal output in groups 2 and 3, triggered by compare match A.

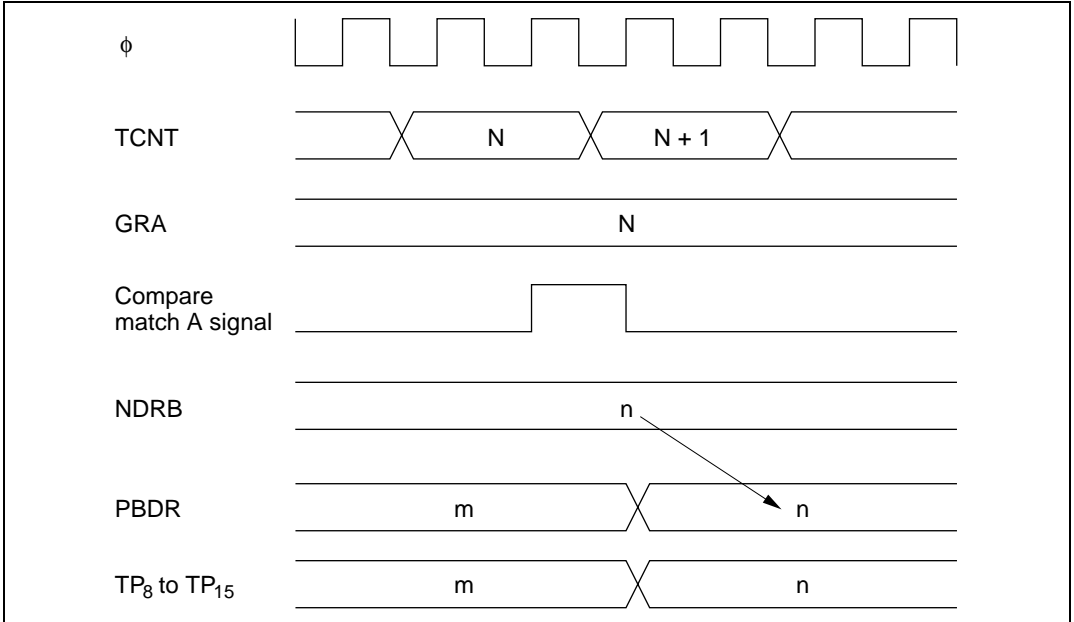

Figure 11.3 Timing of Transfer of Next Data Register Contents and Output (Example)

11.3.3 Normal TPC Output

Sample Setup Procedure for Normal TPC Output

Figure 11.4 shows a sample procedure for setting up normal TPC output.

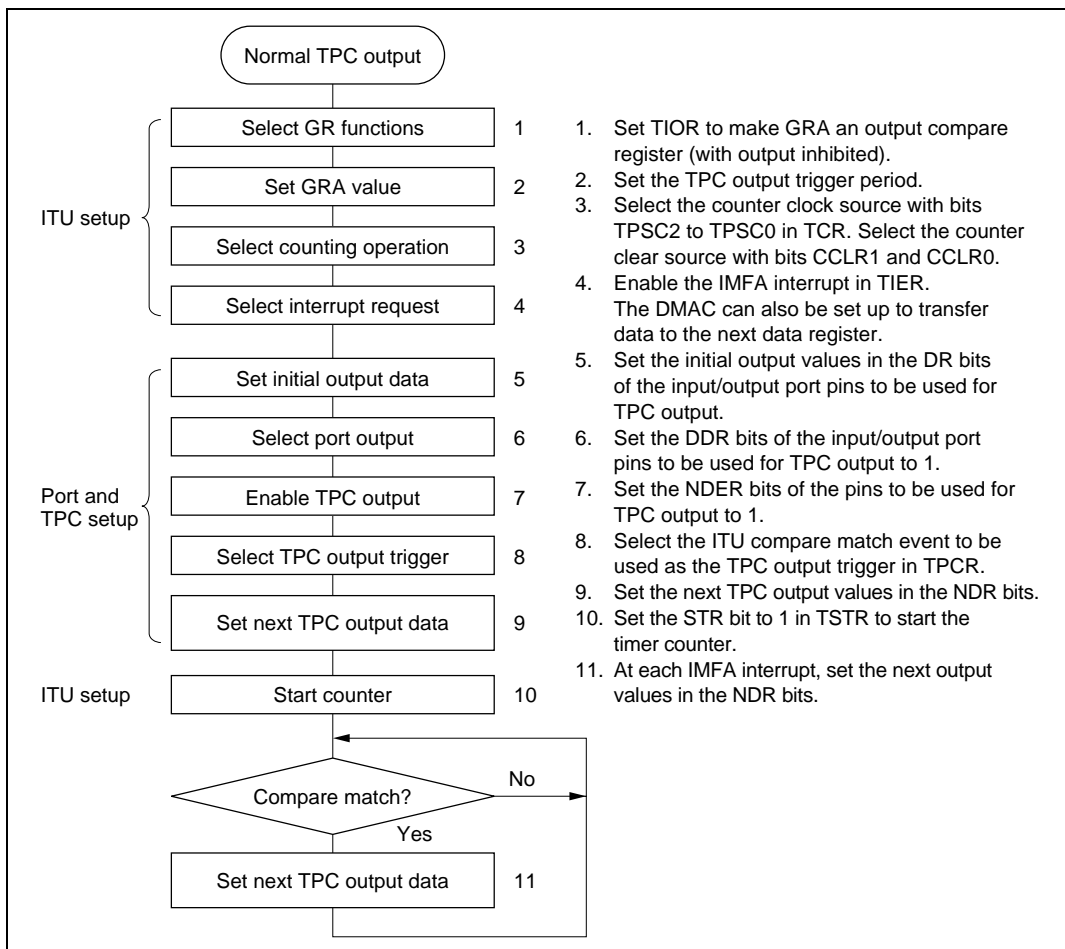

Figure 11.4 Setup Procedure for Normal TPC Output (Example)

Example of Normal TPC Output (Example of Five-Phase Pulse Output)

Figure 11.5 shows an example in which the TPC is used for cyclic five-phase pulse output.

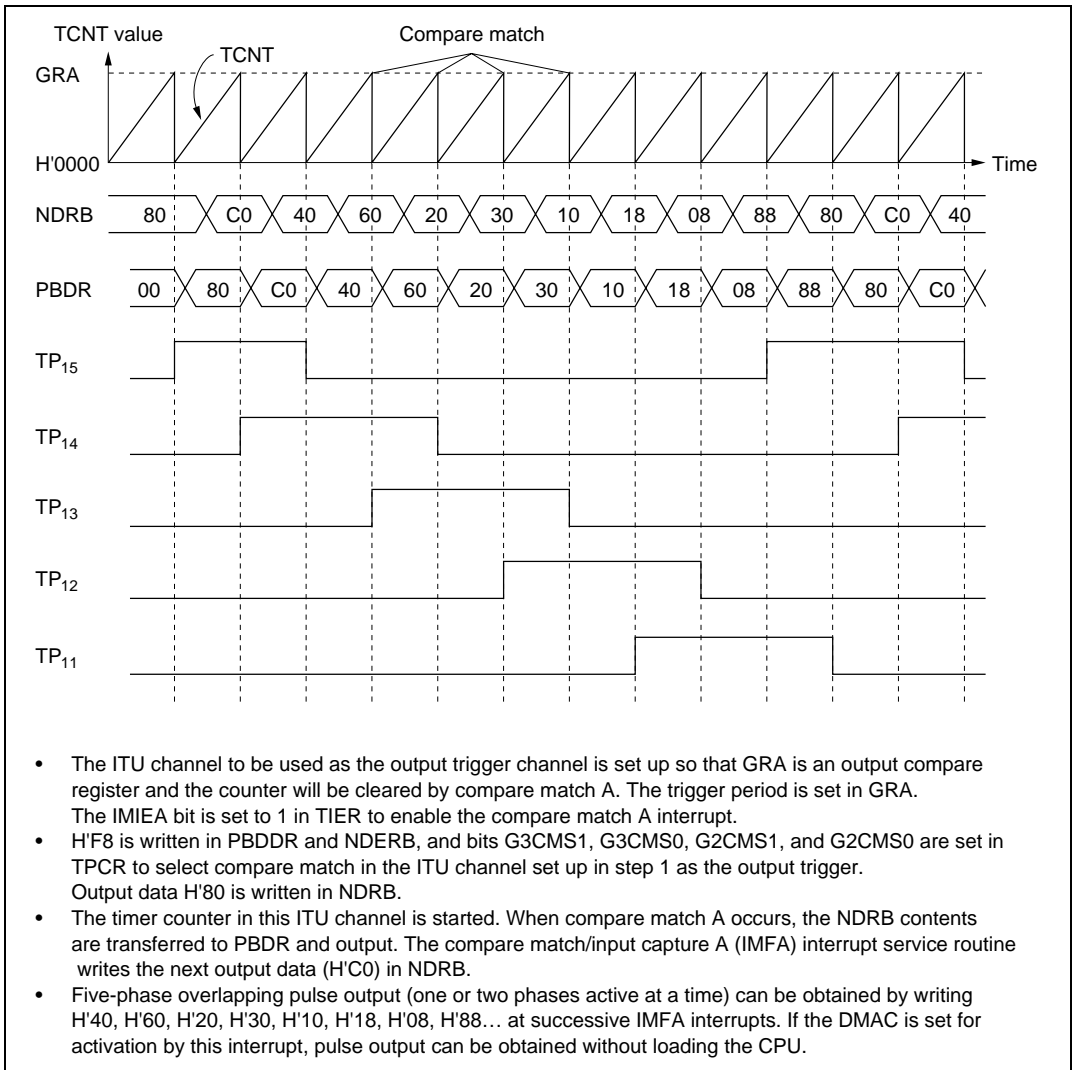

Figure 11.5 Normal TPC Output Example (Five-Phase Pulse Output)

11.3.4 Non-Overlapping TPC Output

Sample Setup Procedure for Non-Overlapping TPC Output

Figure 11.6 shows a sample procedure for setting up non-overlapping TPC output.

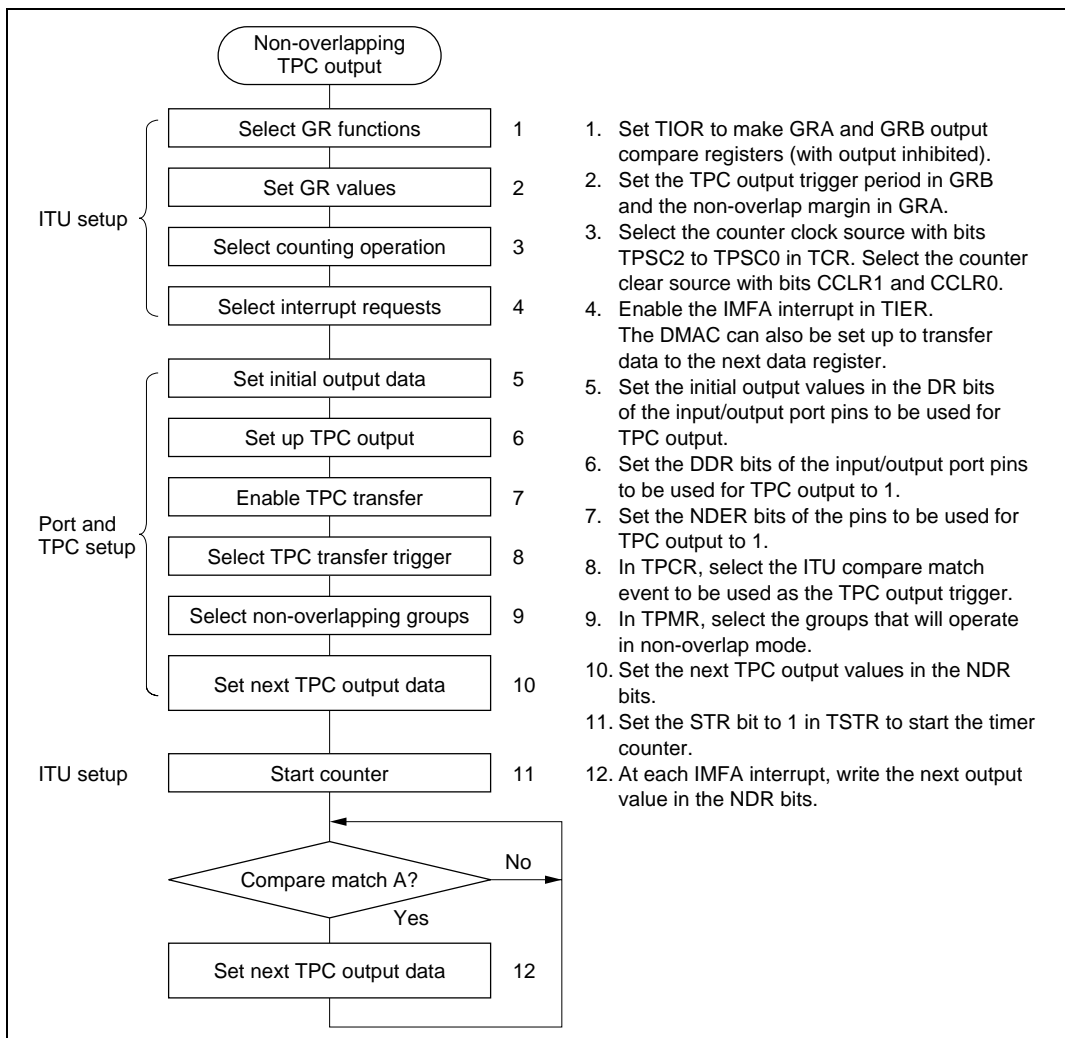
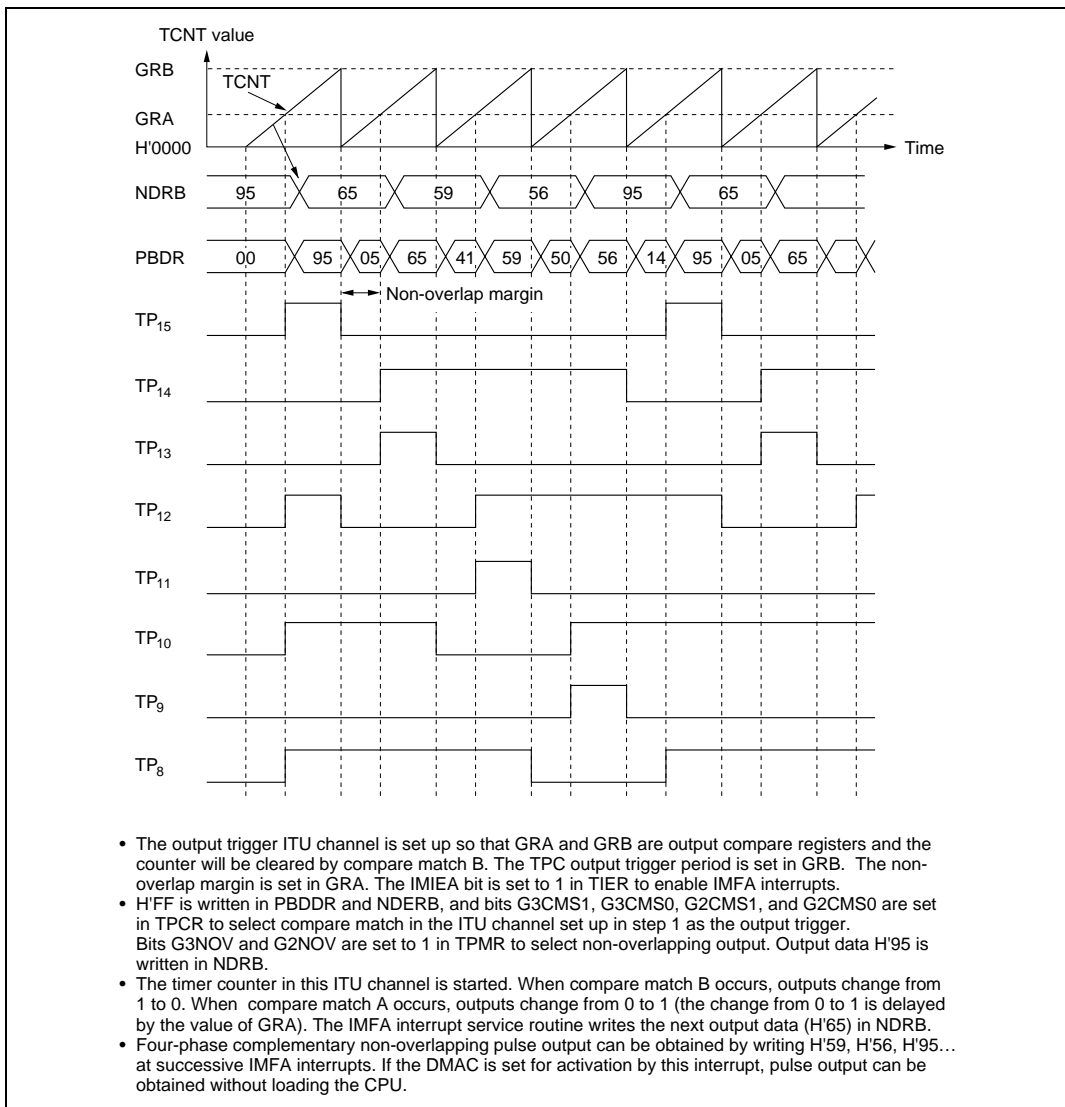

Figure 11.6 Setup Procedure for Non-Overlapping TPC Output (Example)

Example of Non-Overlapping TPC Output (Example of Four-Phase Complementary Non-Overlapping Output)

Figure 11.7 shows an example of the use of TPC output for four-phase complementary non-overlapping pulse output.



**Figure 11.7 Non-Overlapping TPC Output Example
(Four-Phase Complementary Non-Overlapping Pulse Output)**

11.3.5 TPC Output Triggering by Input Capture

TPC output can be triggered by ITU input capture as well as by compare match. If GRA and GRB functions as an input capture register in the ITU channel selected in TPCR, TPC output will be triggered by the input capture signal. Figure 11.8 shows the timing.

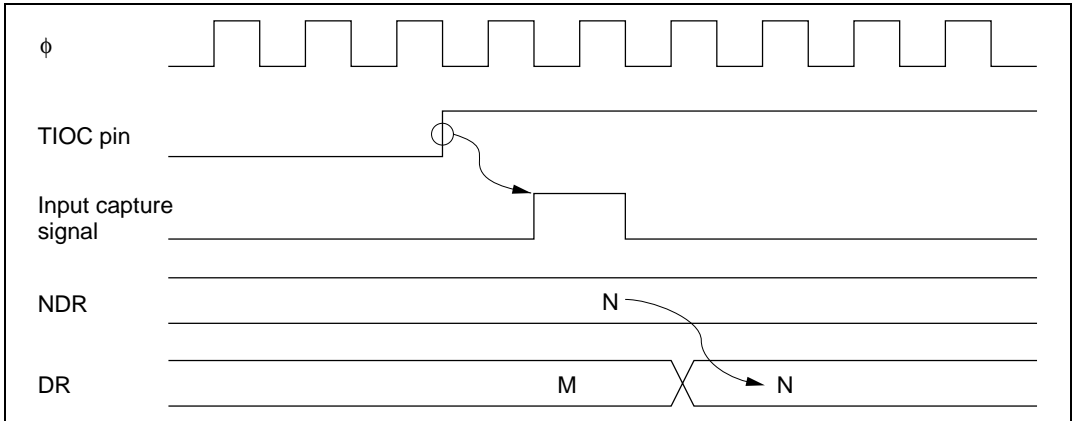

Figure 11.8 TPC Output Triggering by Input Capture (Example)

11.4 Usage Notes

11.4.1 Operation of TPC Output Pins

TP₀ to TP₁₅ are multiplexed with ITU, DMAC, address bus, and other pin functions. When ITU, DMAC, or address output is enabled, the corresponding pins cannot be used for TPC output. The data transfer from NDR bits to DR bits takes place, however, regardless of the usage of the pin.

Pin functions should be changed only under conditions in which the output trigger event will not occur.

11.4.2 Note on Non-Overlapping Output

During non-overlapping operation, the transfer of NDR bit values to DR bits takes place as follows.

1. NDR bits are always transferred to DR bits at compare match A.
2. At compare match B, NDR bits are transferred only if their value is 0. Bits are not transferred if their value is 1.

Figure 11.9 illustrates the non-overlapping TPC output operation.

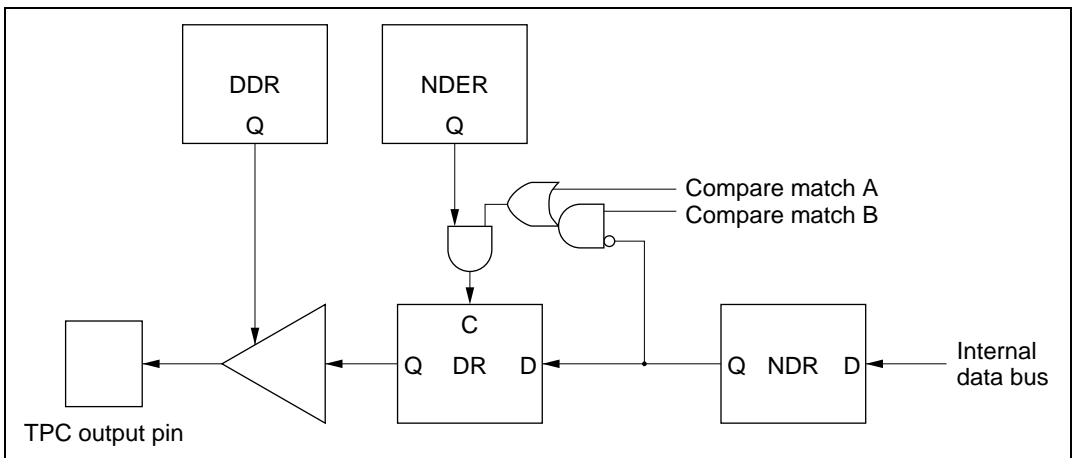

Figure 11.9 Non-Overlapping TPC Output

Therefore, 0 data can be transferred ahead of 1 data by making compare match B occur before compare match A. NDR contents should not be altered during the interval from compare match B to compare match A (the non-overlap margin).

This can be accomplished by having the IMFA interrupt service routine write the next data in NDR, or by having the IMFA interrupt activate the DMAC. The next data must be written before the next compare match B occurs.

Figure 11.10 shows the timing relationships.

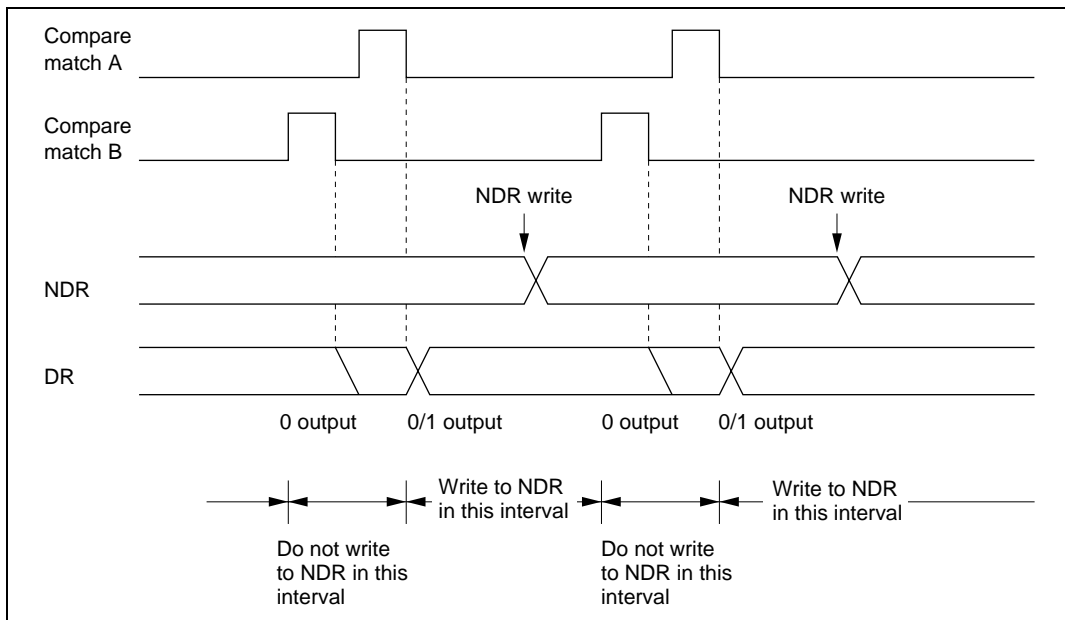

Figure 11.10 Non-Overlapping Operation and NDR Write Timing

Section 12 Watchdog Timer

12.1 Overview

The H8/3048B Group has an on-chip watchdog timer (WDT). The WDT has two selectable functions: it can operate as a watchdog timer to supervise system operation, or it can operate as an interval timer. As a watchdog timer, it generates a reset signal for the chip if a system crash allows the timer counter (TCNT) to overflow before being rewritten. In interval timer operation, an interval timer interrupt is requested at each TCNT overflow.

12.1.1 Features

WDT features are listed below.

- Selection of eight counter clock sources
 $\phi/2$, $\phi/32$, $\phi/64$, $\phi/128$, $\phi/256$, $\phi/512$, $\phi/2048$, or $\phi/4096$
- Interval timer option
- Timer counter overflow generates a reset signal or interrupt.
The reset signal is generated in watchdog timer operation. An interval timer interrupt is generated in interval timer operation.
- The entire chip can be reset internally by a reset signal output from the watchdog timer.
The reset signal generated by timer counter overflow during watchdog timer operation resets the entire chip internally. In an H8/3048F-ONE (single power supply with flash memory), the $\overline{\text{RESO}}$ pin acts as the FWE pin; no external reset signal can be output.

12.1.2 Block Diagram

Figure 12.1 shows a block diagram of the WDT.

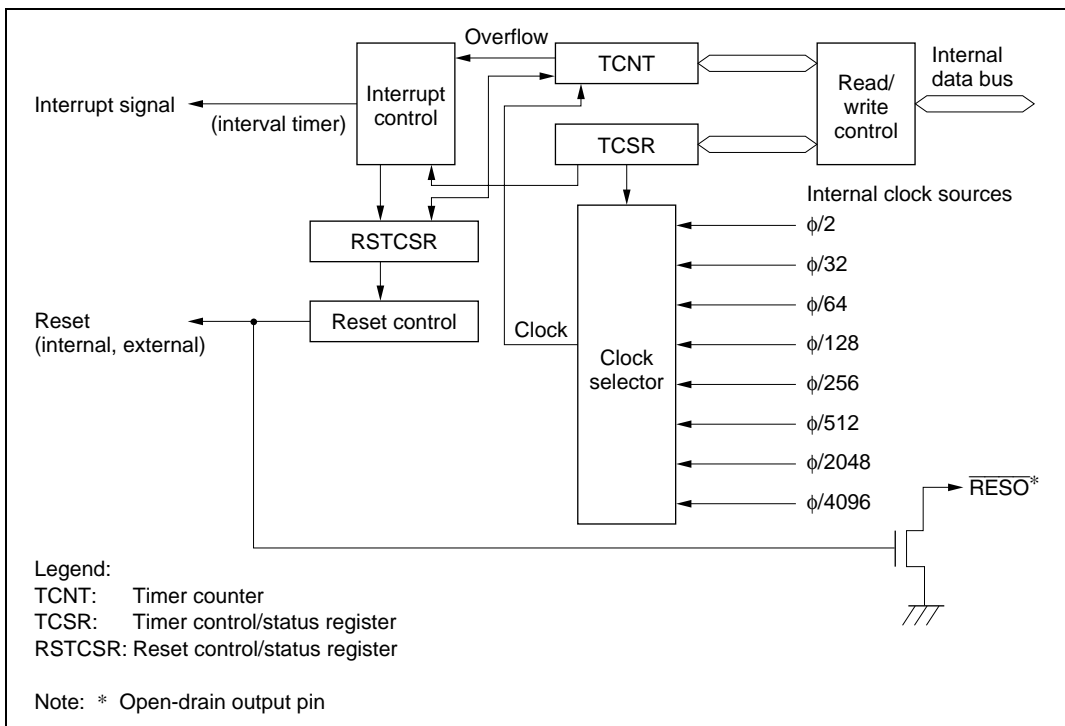

Figure 12.1 WDT Block Diagram

12.1.3 Pin Configuration

Output pins used by the WDT*¹ are shown in table 12.11.

Table 12.1 WDT Pins

Pin Name	Abbreviation	I/O	Function
Reset output	RESO	Output* ²	External output of watchdog timer reset signal

Notes: 1. Not provided in on-chip flash memory versions.

2. Open-drain output pin

12.1.4 Register Configuration

Table 12.2 summarizes the WDT registers.

Table 12.2 WDT Registers

Address ^{*1}		Name	Abbreviation	R/W	Initial Value
Write ^{*2}	Read				
H'FFA8	H'FFA8	Timer control/status register	TCSR	R/(W) ^{*3}	H'18
	H'FFA9	Timer counter	TCNT	R/W	H'00
H'FFAA	H'FFAB	Reset control/status register	RSTCSR	R/(W) ^{*3}	H'3F

- Notes: 1. Lower 16 bits of the address.
 2. Write word data starting at this address.
 3. Only 0 can be written in bit 7, to clear the flag.

12.2 Register Descriptions

12.2.1 Timer Counter (TCNT)

TCNT is an 8-bit readable and writable* up-counter.

Bit	7	6	5	4	3	2	1	0
Initial value	0	0	0	0	0	0	0	0
Read/Write	R/W	R/W	R/W	R/W	R/W	R/W	R/W	R/W

When the TME bit is set to 1 in TCSR, TCNT starts counting pulses generated from an internal clock source selected by bits CKS2 to CKS0 in TCSR. When the count overflows (changes from H'FF to H'00), the OVF bit is set to 1 in TCSR. TCNT is initialized to H'00 by a reset and when the TME bit is cleared to 0.

Note: * TCNT is write-protected by a password. For details see section 12.2.4, Notes on Register Rewriting.

12.2.2 Timer Control/Status Register (TCSR)

TCSR is an 8-bit readable and writable* register. Its functions include selecting the timer mode and clock source.

Note: * TCSR differs from other registers in being more difficult to write. For details see section 12.2.4, Notes on Register Rewriting.

Bit	7	6	5	4	3	2	1	0
	OVF	WT/ \overline{IT}	TME	—	—	CKS2	CKS1	CKS0
Initial value	0	0	0	1	1	0	0	0
Read/Write	R/(W)*	R/W	R/W	—	—	R/W	R/W	R/W

Overflow flag
 Status flag indicating overflow

Timer mode select
 Selects the mode

Timer enable
 Selects whether TCNT runs or halts

Reserved bits

Clock select
 These bits select the TCNT clock source

Note: * Only 0 can be written, to clear the flag.

Bits 7 to 5 are initialized to 0 by a reset and in standby mode. Bits 2 to 0 are initialized to 0 by a reset. In software standby mode bits 2 to 0 are not initialized, but retain their previous values.

Bit 7—Overflow Flag (OVF): This status flag indicates that the timer counter has overflowed from H'FF to H'00.

Bit 7: OVF	Description
0	[Clearing condition] Cleared by reading OVF when OVF = 1, then writing 0 in OVF (Initial value)
1	[Setting condition] Set when TCNT changes from H'FF to H'00

Bit 6—Timer Mode Select (WT/IT̄): Selects whether to use the WDT as a watchdog timer or interval timer. If used as an interval timer, the WDT generates an interval timer interrupt request when TCNT overflows. If used as a watchdog timer, the WDT generates a reset signal when TCNT overflows.

Bit 6: WT/IT̄	Description
0	Interval timer: requests interval timer interrupts (Initial value)
1	Watchdog timer: generates a reset signal

Bit 5—Timer Enable (TME): Selects whether TCNT runs or is halted.

When WT/IT̄ = 1, clear the SYSCR software standby bit (SSBY) to 0, then set the TME to 1.

When SSBY is set to 1, clear TME to 0.

Bit 5: TME	Description
0	TCNT is initialized to H'00 and halted (Initial value)
1	TCNT is counting and CPU interrupt requests are enabled

Bits 4 and 3—Reserved: Read-only bits, always read as 1.

Bits 2 to 0—Clock Select 2 to 0 (CKS2 to CKS0): These bits select one of eight internal clock sources, obtained by prescaling the system clock (ϕ), for input to TCNT.

Bit 2: CKS2	Bit 1: CKS1	Bit 0: CKS0	Description
0	0	0	$\phi/2$ (Initial value)
		1	$\phi/32$
	1	0	$\phi/64$
		1	$\phi/128$
1	0	0	$\phi/256$
		1	$\phi/512$
	1	0	$\phi/2048$
		1	$\phi/4096$

12.2.3 Reset Control/Status Register (RSTCSR)

RSTCSR is an 8-bit readable and writable register that indicates when a reset signal has been generated by watchdog timer overflow, and controls external output of the reset signal.

Bit	7	6	5	4	3	2	1	0
	WRST	RSTOE	—	—	—	—	—	—
Initial value	0	0	1	1	1	1	1	1
Read/Write	R/(W)*	R/W	—	—	—	—	—	—

Reserved bits

Reset output enable
Enables or disables external output of the reset signal

Watchdog timer reset
Indicates that a reset signal has been generated

Notes: The method for writing to RSTCSR is different from that for general registers to prevent inadvertent overwriting. For details see section 12.2.4, Notes on Register Rewriting.

* Only 0 can be written in bit 7, to clear the flag.

Bits 7 and 6 are initialized by input of a reset signal at the $\overline{\text{RES}}$ pin. They are not initialized by reset signals generated by watchdog timer overflow.

Bit 7—Watchdog Timer Reset (WRST): During watchdog timer operation, this bit indicates that TCNT has overflowed and generated a reset signal. This reset signal resets the entire chip internally. If bit RSTOE is set to 1, this reset signal is also output (low) at the $\overline{\text{RESO}}$ pin to initialize external system devices. Note that there is no $\overline{\text{RESO}}$ pin in the versions with on-chip flash memory.

Bit 7

WRST	Description
0	[Clearing conditions] <ul style="list-style-type: none"> • Reset signal at $\overline{\text{RES}}$ pin. • Read WRST when WRST = 1, then write 0 in WRST. (Initial value)
1	[Setting condition] <p>Set when TCNT overflow generates a reset signal during watchdog timer operation</p>

Bit 6—Reset Output Enable (RSTOE): Enables or disables external output at the $\overline{\text{RESO}}$ pin of the reset signal generated if TCNT overflows during watchdog timer operation. Note that there is no $\overline{\text{RESO}}$ pin in the versions with on-chip flash memory.

Bit 6

RSTOE	Description	
0	Reset signal is not output externally	(Initial value)
1	Reset signal is output externally	

Bits 5 to 0—Reserved: These bits cannot be modified and are always read as 1.

12.2.4 Notes on Register Rewriting

The watchdog timer's TCNT, TCSR, and RSTCSR registers differ from other registers in being more difficult to write. The procedures for writing and reading these registers are given below.

Writing to TCNT and TCSR

These registers must be written by a word transfer instruction. They cannot be written by byte instructions. Figure 12.2 shows the format of data written to TCNT and TCSR. TCNT and TCSR both have the same write address. The write data must be contained in the lower byte of the written word. The upper byte must contain H'5A (password for TCNT) or H'A5 (password for TCSR). This transfers the write data from the lower byte to TCNT or TCSR.

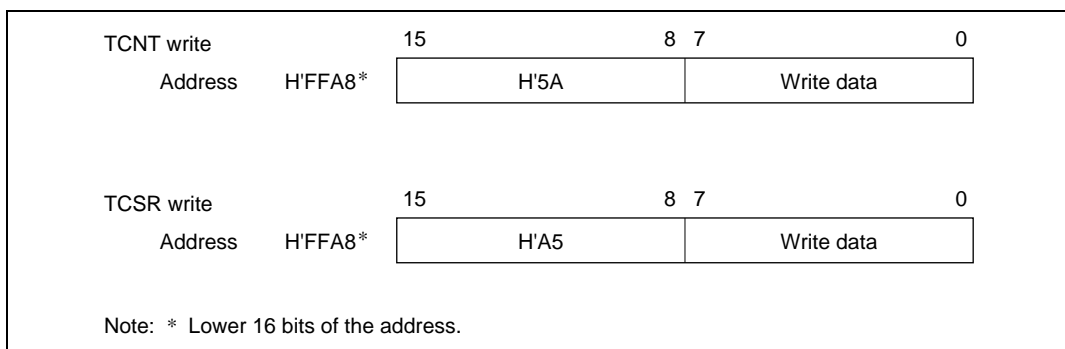

Figure 12.2 Format of Data Written to TCNT and TCSR

Writing to RSTCSR

RSTCSR must be written by a word transfer instruction. It cannot be written by byte transfer instructions. Figure 12.3 shows the format of data written to RSTCSR. To write 0 in the WRST bit, the write data must have H'A5 in the upper byte and H'00 in the lower byte. The H'00 in the lower byte clears the WRST bit in RSTCSR to 0. To write to the RSTOE bit, the upper byte must contain H'5A and the lower byte must contain the write data. Writing this word transfers a write data value into the RSTOE bit.

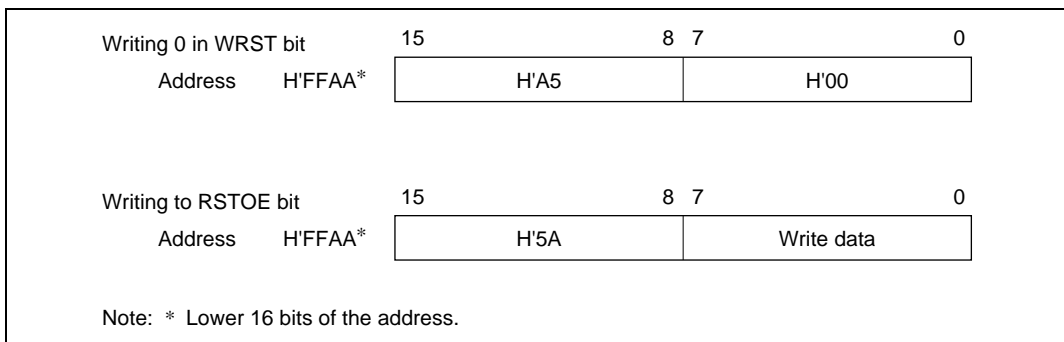

Figure 12.3 Format of Data Written to RSTCSR

Reading TCNT, TCSR, and RSTCSR

These registers are read like other registers. Byte access instructions can be used. The read addresses are H'FFA8 for TCSR, H'FFA9 for TCNT, and H'FFAB for RSTCSR, as listed in table 12.3.

Table 12.3 Read Addresses of TCNT, TCSR, and RSTCSR

Address*	Register
H'FFA8	TCSR
H'FFA9	TCNT
H'FFAB	RSTCSR

Note: * Lower 16 bits of the address.

12.3 Operation

Operations when the WDT is used as a watchdog timer and as an interval timer are described below.

12.3.1 Watchdog Timer Operation

Figure 12.4 illustrates watchdog timer operation. To use the WDT as a watchdog timer, set the $\overline{WT}/\overline{IT}$ and TME bits to 1 in TCSR. Software must prevent TCNT overflow by rewriting the TCNT value (normally by writing H'00) before overflow occurs. If TCNT fails to be rewritten and overflows due to a system crash etc., the chip is internally reset for a duration of 518 states.

The watchdog reset signal can be externally output from the \overline{RESO} pin to reset external system devices. The reset signal is output externally for 132 states. External output can be enabled or disabled by the RSTOE bit in RSTCSR. Note that there is no \overline{RESO} pin in the versions with on-chip flash memory.

A watchdog reset has the same vector as a reset generated by input at the \overline{RES} pin. Software can distinguish a \overline{RES} reset from a watchdog reset by checking the WRST bit in RSTCSR.

If a \overline{RES} reset and a watchdog reset occur simultaneously, the \overline{RES} reset takes priority.

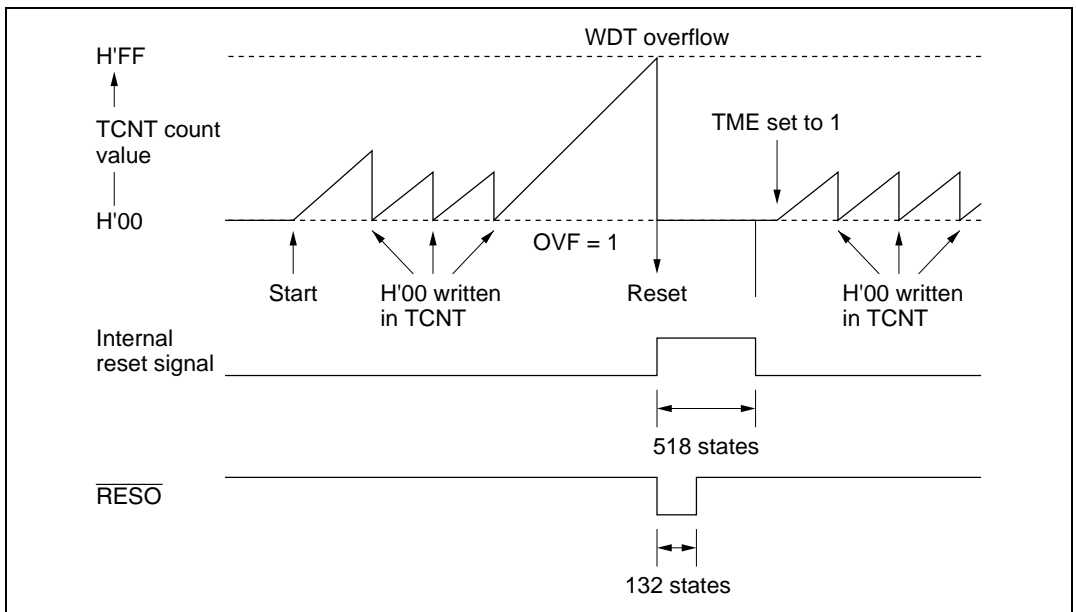

Figure 12.4 Watchdog Timer Operation

12.3.2 Interval Timer Operation

Figure 12.5 illustrates interval timer operation. To use the WDT as an interval timer, clear bit WT/\overline{IT} to 0 and set bit TME to 1 in TCSR. An interval timer interrupt request is generated at each TCNT overflow. This function can be used to generate interval timer interrupts at regular intervals.

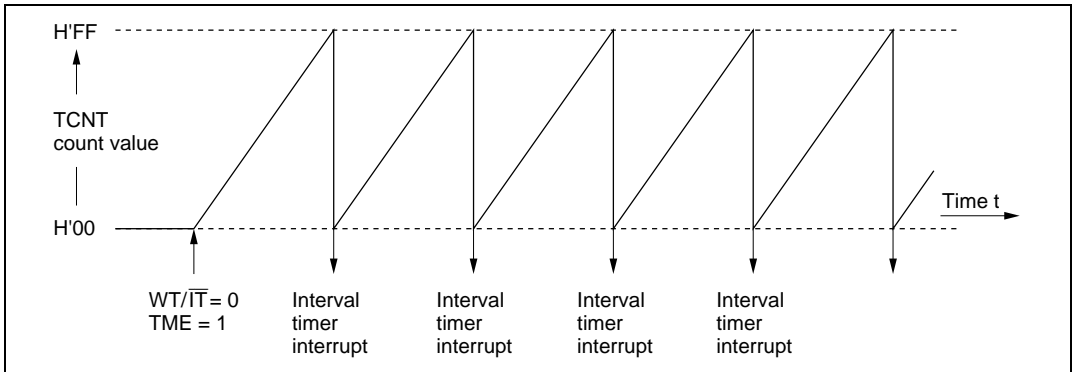

Figure 12.5 Interval Timer Operation

12.3.3 Timing of Setting of Overflow Flag (OVF)

Figure 12.6 shows the timing of setting of the OVF flag in TCSR. The OVF flag is set to 1 when TCNT overflows. At the same time, a reset signal is generated in watchdog timer operation, or an interval timer interrupt is generated in interval timer operation.

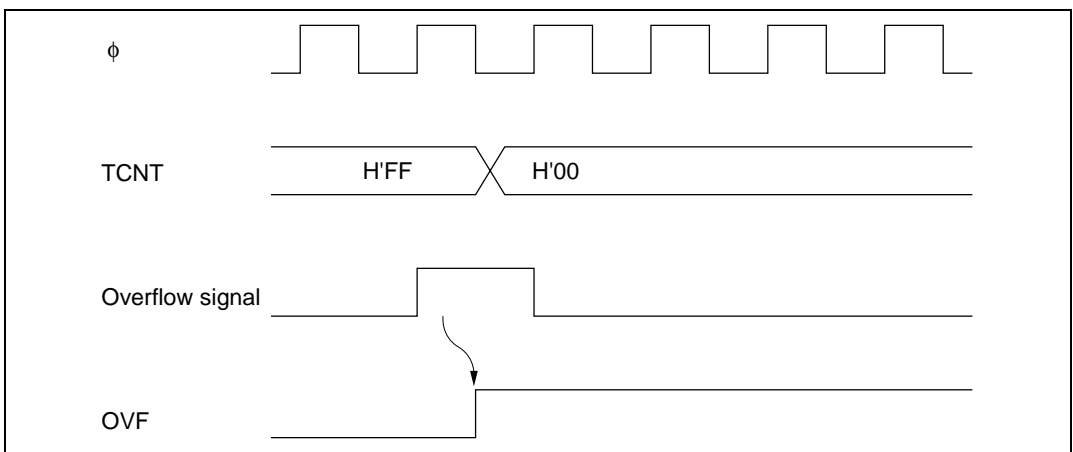

Figure 12.6 Timing of Setting of OVF

12.3.4 Timing of Setting of Watchdog Timer Reset Bit (WRST)

The WRST bit in RSTCSR is valid when bits $\overline{WT/IT}$ and TME are both set to 1 in TCSR.

Figure 12.7 shows the timing of setting of WRST and the internal reset timing. The WRST bit is set to 1 when TCNT overflows and OVF is set to 1. At the same time an internal reset signal is generated for the entire chip. This internal reset signal clears OVF to 0, but the WRST bit remains set to 1. The reset routine must therefore clear the WRST bit.

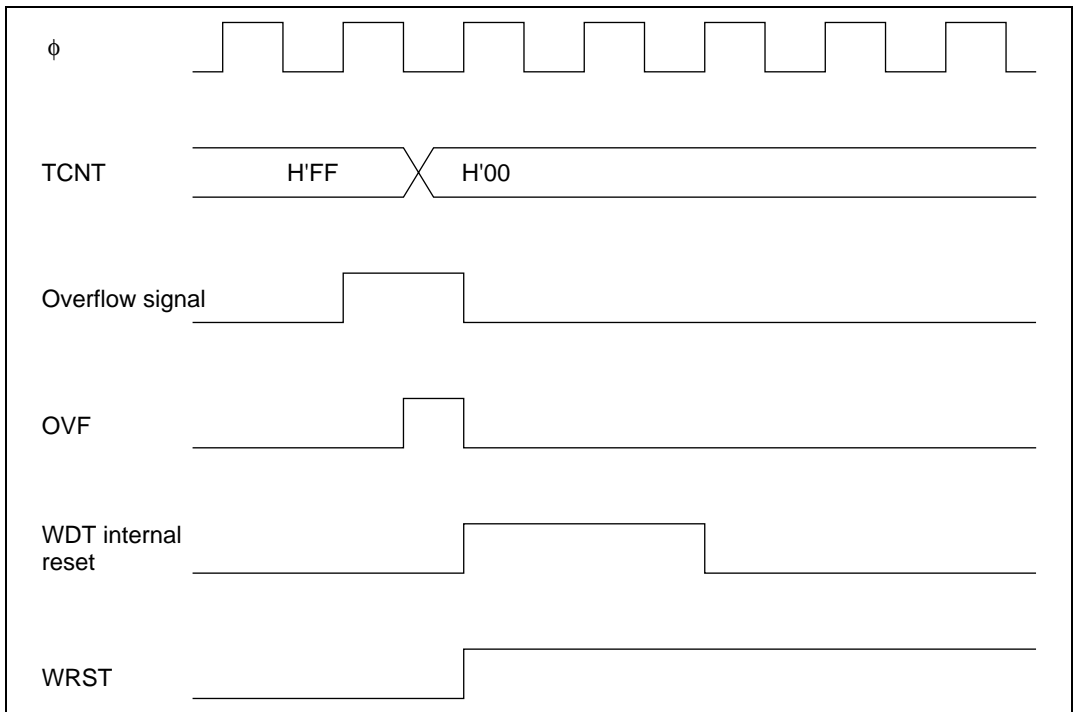

Figure 12.7 Timing of Setting of WRST Bit and Internal Reset

12.4 Interrupts

During interval timer operation, an overflow generates an interval timer interrupt (WOVI). The interval timer interrupt is requested whenever the OVF bit is set to 1 in TCSR.

12.5 Usage Notes

Contention between TCNT Write and Increment

If a timer counter clock pulse is generated during the T_3 state of a write cycle to TCNT, the write takes priority and the timer count is not incremented. See figure 12.8.

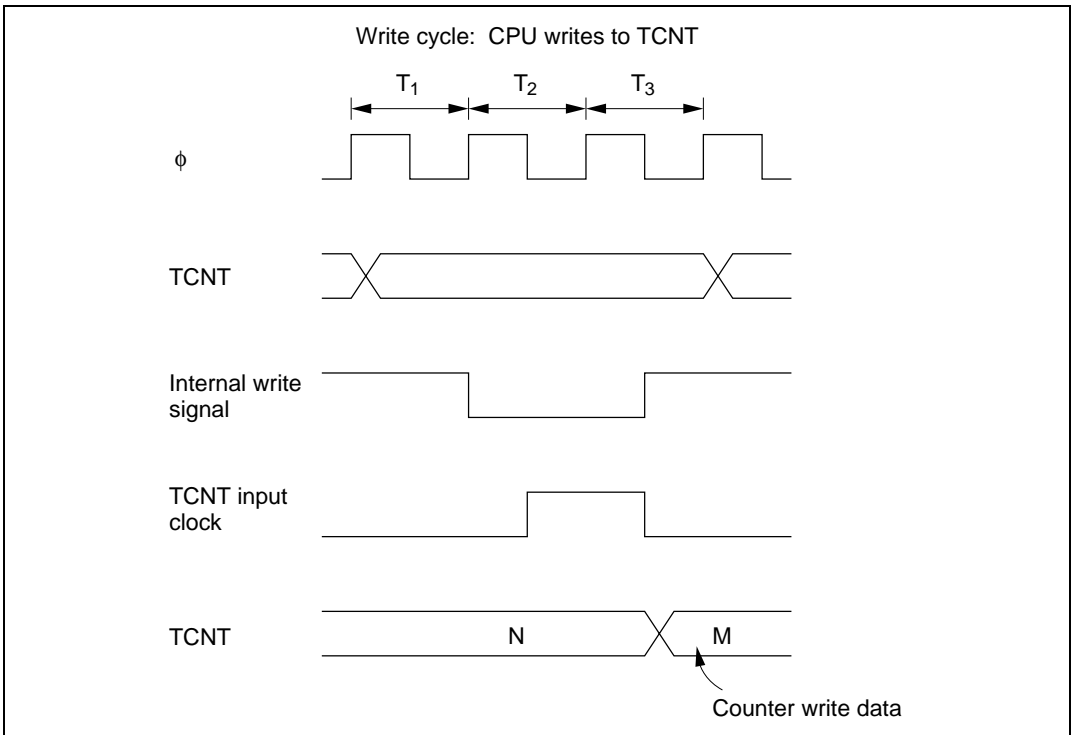

Figure 12.8 Contention between TCNT Write and Increment

Changing CKS2 to CKS0 Values

Halt TCNT by clearing the TME bit to 0 in TCSR before changing the values of bits CKS2 to CKS0.

12.6 Notes

This chip incorporates an WDT. The timer counter value of the on-chip WDT is not rewritten, even if a system crash occurs. If an overflow occurs, a reset signal is generated and the chip is reset.

However, if the following three events occur due to a CPU overrun, for example, the above operations cannot be guaranteed since the WDT and the CPU are incorporated in the same chip.

- When the internal I/O registers related to the on-chip WDT are rewritten.
- When software standby mode is incorrectly entered.
- When the break mode is incorrectly entered.

In addition, as stated in the NMI above, if an abnormal level is input into the power supply pins or the system control pins, correct operations cannot be guaranteed.

Except the above cases, the on-chip WDT functions as a device that supports recovery from a system crash. Accordingly, when a fail-safe function is required in your system, an additional circuit may be required as necessary.

Section 13 Serial Communication Interface

13.1 Overview

The H8/3048B Group has a serial communication interface (SCI) with two independent channels. The two channels are functionally identical. The SCI can communicate in asynchronous or synchronous mode. It also has a multiprocessor communication function for serial communication among two or more processors.

When the SCI is not used, it can be halted to conserve power. Each SCI channel can be halted independently. For details see section 20.6, Module Standby Function.

Channel 0 (SCIO) also has a smart card interface function conforming to the ISO/IEC7816-3 (Identification Card) standard. This function supports serial communication with a smart card. For details, see section 14, Smart Card Interface.

13.1.1 Features

SCI features are listed below.

- Selection of asynchronous or synchronous mode for serial communication
 - Asynchronous mode

Serial data communication is synchronized one character at a time. The SCI can communicate with a universal asynchronous receiver/transmitter (UART), asynchronous communication interface adapter (ACIA), or other chip that employs standard asynchronous serial communication. It can also communicate with two or more other processors using the multiprocessor communication function. There are twelve selectable serial data communication formats.

 - Data length: 7 or 8 bits
 - Stop bit length: 1 or 2 bits
 - Parity bit: even, odd, or none
 - Multiprocessor bit: 1 or 0
 - Receive error detection: parity, overrun, and framing errors
 - Break detection: by reading the RxD level directly when a framing error occurs

— Synchronous mode

Serial data communication is synchronized with a clock signal. The SCI can communicate with other chips having a synchronous communication function. There is one serial data communication format.

- Data length: 8 bits
- Receive error detection: overrun errors

• Full duplex communication

The transmitting and receiving sections are independent, so the SCI can transmit and receive simultaneously. The transmitting and receiving sections are both double-buffered, so serial data can be transmitted and received continuously.

- Built-in baud rate generator with selectable bit rates
- Selectable transmit/receive clock sources: internal clock from baud rate generator, or external clock from the SCK pin.
- Four types of interrupts

Transmit-data-empty, transmit-end, receive-data-full, and receive-error interrupts are requested independently. The transmit-data-empty and receive-data-full interrupts from SCIO can activate the DMA controller (DMAC) to transfer data.

13.1.2 Block Diagram

Figure 13.1 shows a block diagram of the SCI.

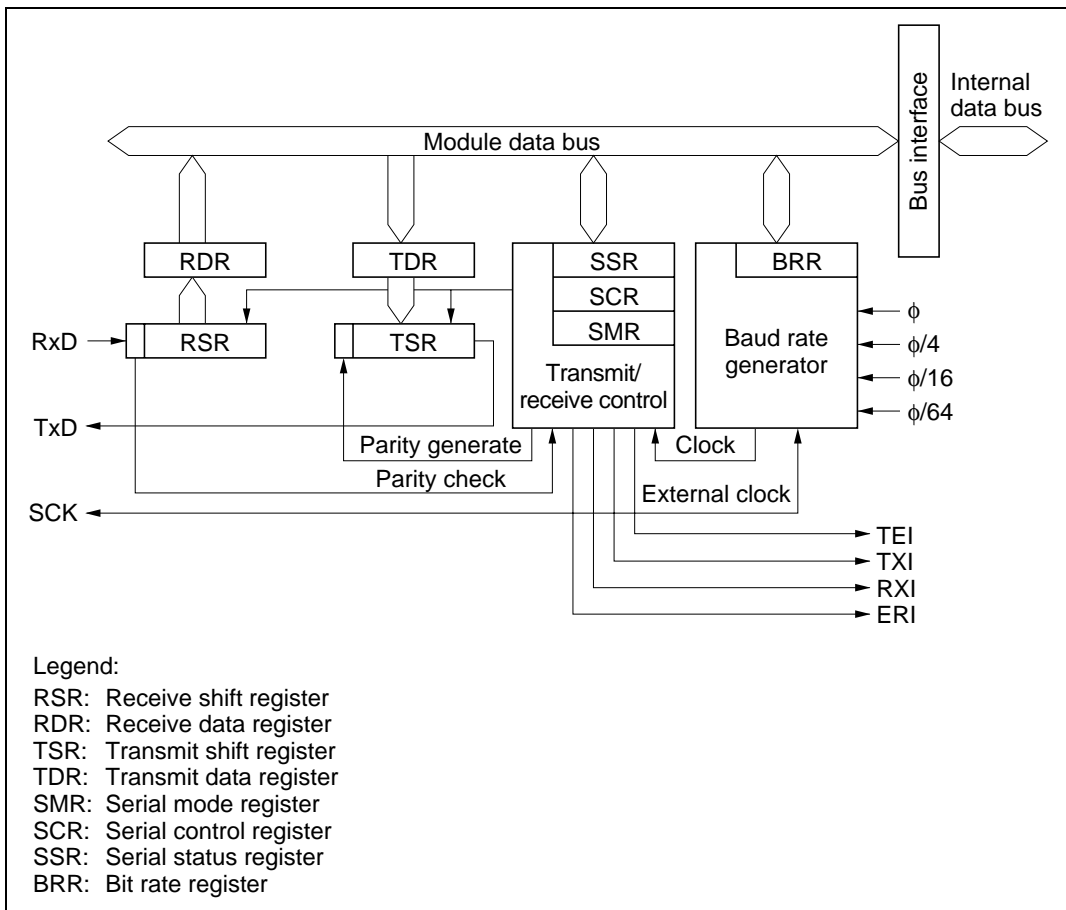

Figure 13.1 SCI Block Diagram

13.1.3 Input/Output Pins

The SCI has serial pins for each channel as listed in table 13.1.

Table 13.1 SCI Pins

Channel	Name	Abbreviation	I/O	Function
0	Serial clock pin	SCK ₀	Input/output	SCI ₀ clock input/output
	Receive data pin	RxD ₀	Input	SCI ₀ receive data input
	Transmit data pin	TxD ₀	Output	SCI ₀ transmit data output
1	Serial clock pin	SCK ₁	Input/output	SCI ₁ clock input/output
	Receive data pin	RxD ₁	Input	SCI ₁ receive data input
	Transmit data pin	TxD ₁	Output	SCI ₁ transmit data output

13.1.4 Register Configuration

The SCI has internal registers as listed in table 13.2. These registers select asynchronous or synchronous mode, specify the data format and bit rate, and control the transmitter and receiver sections.

Table 13.2 Registers

Channel	Address ^{*1}	Name	Abbreviation	R/W	Initial Value
0	H'FFB0	Serial mode register	SMR	R/W	H'00
	H'FFB1	Bit rate register	BRR	R/W	H'FF
	H'FFB2	Serial control register	SCR	R/W	H'00
	H'FFB3	Transmit data register	TDR	R/W	H'FF
	H'FFB4	Serial status register	SSR	R/(W) ^{*2}	H'84
	H'FFB5	Receive data register	RDR	R	H'00
1	H'FFB8	Serial mode register	SMR	R/W	H'00
	H'FFB9	Bit rate register	BRR	R/W	H'FF
	H'FFBA	Serial control register	SCR	R/W	H'00
	H'FFBB	Transmit data register	TDR	R/W	H'FF
	H'FFBC	Serial status register	SSR	R/(W) ^{*2}	H'84
	H'FFBD	Receive data register	RDR	R	H'00

Notes: 1. Lower 16 bits of the address.

2. Only 0 can be written, to clear flags.

13.2 Register Descriptions

13.2.1 Receive Shift Register (RSR)

RSR is the register that receives serial data.

Bit	7	6	5	4	3	2	1	0
Read/Write	—	—	—	—	—	—	—	—

The SCI loads serial data input at the RxD pin into RSR in the order received, LSB (bit 0) first, thereby converting the data to parallel data. When 1 byte has been received, it is automatically transferred to RDR. The CPU cannot read or write RSR directly.

13.2.2 Receive Data Register (RDR)

RDR is the register that stores received serial data.

Bit	7	6	5	4	3	2	1	0
Initial value	0	0	0	0	0	0	0	0
Read/Write	R	R	R	R	R	R	R	R

When the SCI finishes receiving 1 byte of serial data, it transfers the received data from RSR into RDR for storage. RSR is then ready to receive the next data. This double buffering allows data to be received continuously.

RDR is a read-only register. Its contents cannot be modified by the CPU. RDR is initialized to H'00 by a reset and in standby mode.

13.2.3 Transmit Shift Register (TSR)

TSR is the register that transmits serial data.

Bit	7	6	5	4	3	2	1	0
Read/Write	—	—	—	—	—	—	—	—

The SCI loads transmit data from TDR into TSR, then transmits the data serially from the TxD pin, LSB (bit 0) first. After transmitting one data byte, the SCI automatically loads the next transmit data from TDR into TSR and starts transmitting it. If the TDRE flag is set to 1 in SSR, however, the SCI does not load the TDR contents into TSR. The CPU cannot read or write TSR directly.

13.2.4 Transmit Data Register (TDR)

TDR is an 8-bit register that stores data for serial transmission.

Bit	7	6	5	4	3	2	1	0
Initial value	1	1	1	1	1	1	1	1
Read/Write	R/W	R/W	R/W	R/W	R/W	R/W	R/W	R/W

When the SCI detects that TSR is empty, it moves transmit data written in TDR from TDR into TSR and starts serial transmission. Continuous serial transmission is possible by writing the next transmit data in TDR during serial transmission from TSR.

The CPU can always read and write TDR. TDR is initialized to H'FF by a reset and in standby mode.

13.2.5 Serial Mode Register (SMR)

SMR is an 8-bit register that specifies the SCI serial communication format and selects the clock source for the baud rate generator.

Bit	7	6	5	4	3	2	1	0
	C/\bar{A}	CHR	PE	O/\bar{E}	STOP	MP	CKS1	CKS0
Initial value	0	0	0	0	0	0	0	0
Read/Write	R/W	R/W	R/W	R/W	R/W	R/W	R/W	R/W

Communication mode
Selects asynchronous or synchronous mode

Character length
Selects character length in asynchronous mode

Parity enable
Selects whether a parity bit is added

Parity mode
Selects even or odd parity

Stop bit length
Selects the stop bit length

Multiprocessor mode
Selects the multiprocessor function

Clock select 1/0
These bits select the baud rate generator's clock source

The CPU can always read and write SMR. SMR is initialized to H'00 by a reset and in standby mode.

Bit 7—Communication Mode (C/\bar{A}): Selects whether the SCI operates in asynchronous or synchronous mode.

Bit 7: C/\bar{A}	Description
0	Asynchronous mode (Initial value)
1	Synchronous mode

Bit 6—Character Length (CHR): Selects 7-bit or 8-bit data length in asynchronous mode. In synchronous mode the data length is 8 bits regardless of the CHR setting.

Bit 6: CHR	Description	
0	8-bit data	(Initial value)
1	7-bit data*	

Note: * When 7-bit data is selected, the MSB (bit 7) in TDR is not transmitted.

Bit 5—Parity Enable (PE): In asynchronous mode, this bit enables or disables the addition of a parity bit to transmit data, and the checking of the parity bit in receive data. In synchronous mode the parity bit is neither added nor checked, regardless of the PE setting.

Bit 5: PE	Description	
0	Parity bit not added or checked	(Initial value)
1	Parity bit added and checked*	

Note: * When PE is set to 1, an even or odd parity bit is added to transmit data according to the even or odd parity mode selected by the O/\bar{E} bit, and the parity bit in receive data is checked to see that it matches the even or odd mode selected by the O/\bar{E} bit.

Bit 4—Parity Mode (O/\bar{E}): Selects even or odd parity. The O/\bar{E} bit setting is valid in asynchronous mode when the PE bit is set to 1 to enable the adding and checking of a parity bit. The O/\bar{E} setting is ignored in synchronous mode, or when parity adding and checking is disabled in asynchronous mode.

Bit 4: O/\bar{E}	Description	
0	Even parity* ¹	(Initial value)
1	Odd parity* ²	

Notes: 1. When even parity is selected, the parity bit added to transmit data makes an even number of 1s in the transmitted character and parity bit combined. Receive data must have an even number of 1s in the received character and parity bit combined.
 2. When odd parity is selected, the parity bit added to transmit data makes an odd number of 1s in the transmitted character and parity bit combined. Receive data must have an odd number of 1s in the received character and parity bit combined.

Bit 3—Stop Bit Length (STOP): Selects one or two stop bits in asynchronous mode. This setting is used only in asynchronous mode. In synchronous mode no stop bit is added, so the STOP bit setting is ignored.

Bit 3: STOP	Description	
0	One stop bit ^{*1}	(Initial value)
1	Two stop bits ^{*2}	

Notes: 1. One stop bit (with value 1) is added at the end of each transmitted character.
2. Two stop bits (with value 1) are added at the end of each transmitted character.

In receiving, only the first stop bit is checked, regardless of the STOP bit setting. If the second stop bit is 1 it is treated as a stop bit. If the second stop bit is 0 it is treated as the start bit of the next incoming character.

Bit 2—Multiprocessor Mode (MP): Selects a multiprocessor format. When a multiprocessor format is selected, parity settings made by the PE and O/E bits are ignored. The MP bit setting is valid only in asynchronous mode. It is ignored in synchronous mode.

For further information on the multiprocessor communication function, see section 13.3.3, Multiprocessor Communication.

Bit 2: MP	Description	
0	Multiprocessor function disabled	(Initial value)
1	Multiprocessor format selected	

Bits 1 and 0—Clock Select 1 and 0 (CKS1, CKS0): These bits select the clock source of the on-chip baud rate generator. Four clock sources are available: ϕ , $\phi/4$, $\phi/16$, and $\phi/64$.

For the relationship between the clock source, bit rate register setting, and baud rate, see section 13.2.8, Bit Rate Register (BRR).

Bit 1: CKS1	Bit 0: CKS0	Description	
0	0	ϕ	(Initial value)
	1	$\phi/4$	
1	0	$\phi/16$	
	1	$\phi/64$	

13.2.6 Serial Control Register (SCR)

SCR enables the SCI transmitter and receiver, enables or disables serial clock output in asynchronous mode, enables or disables interrupts, and selects the transmit/receive clock source.

Bit	7	6	5	4	3	2	1	0
	TIE	RIE	TE	RE	MPIE	TEIE	CKE1	CKE0
Initial value	0	0	0	0	0	0	0	0
Read/Write	R/W	R/W	R/W	R/W	R/W	R/W	R/W	R/W

Transmit interrupt enable
Enables or disables transmit-data-empty interrupts (TXI)

Receive interrupt enable
Enables or disables receive-data-full interrupts (RXI) and receive-error interrupts (ERI)

Transmit enable
Enables or disables the transmitter

Receive enable
Enables or disables the receiver

Multiprocessor interrupt enable
Enables or disables multiprocessor interrupts

Transmit-end interrupt enable
Enables or disables transmit-end interrupts (TEI)

Clock enable 1/0
These bits select the SCI clock source

The CPU can always read and write SCR. SCR is initialized to H'00 by a reset and in standby mode.

Bit 7—Transmit Interrupt Enable (TIE): Enables or disables the transmit-data-empty interrupt (TXI) requested when the TDRE flag in SSR is set to 1 due to transfer of serial transmit data from TDR to TSR.

Bit 7: TIE	Description
0	Transmit-data-empty interrupt request (TXI) is disabled* (Initial value)
1	Transmit-data-empty interrupt request (TXI) is enabled

Note: * TXI interrupt requests can be cleared by reading the value 1 from the TDRE flag, then clearing it to 0; or by clearing the TIE bit to 0.

Bit 6—Receive Interrupt Enable (RIE): Enables or disables the receive-data-full interrupt (RXI) requested when the RDRF flag is set to 1 in SSR due to transfer of serial receive data from RSR to RDR; also enables or disables the receive-error interrupt (ERI).

Bit 6: RIE	Description
0	Receive-data-full (RXI) and receive-error (ERI) interrupt requests are disabled* (Initial value)
1	Receive-data-full (RXI) and receive-error (ERI) interrupt requests are enabled

Note: * RXI and ERI interrupt requests can be cleared by reading the value 1 from the RDRF, FER, PER, or ORER flag, then clearing it to 0; or by clearing the RIE bit to 0.

Bit 5—Transmit Enable (TE): Enables or disables the start of SCI serial transmitting operations.

Bit 5: TE	Description
0	Transmitting disabled* ¹ (Initial value)
1	Transmitting enabled ^{1:2}

Notes: 1. The TDRE bit is locked at 1 in SSR.

- In the enabled state, serial transmitting starts when the TDRE bit in SSR is cleared to 0 after writing of transmit data into TDR. Select the transmit format in SMR before setting the TE bit to 1.

Bit 4—Receive Enable (RE): Enables or disables the start of SCI serial receiving operations.

Bit 4: RE	Description
0	Receiving disabled ^{*1} (Initial value)
1	Receiving enabled ^{*2}

- Notes:
1. Clearing the RE bit to 0 does not affect the RDRF, FER, PER, and ORER flags. These flags retain their previous values.
 2. In the enabled state, serial receiving starts when a start bit is detected in asynchronous mode, or serial clock input is detected in synchronous mode. Select the receive format in SMR before setting the RE bit to 1.

Bit 3—Multiprocessor Interrupt Enable (MPIE): Enables or disables multiprocessor interrupts. The MPIE setting is valid only in asynchronous mode, and only if the MP bit is set to 1 in SMR. The MPIE setting is ignored in synchronous mode or when the MP bit is cleared to 0.

Bit 3: MPIE	Description
0	Multiprocessor interrupts are disabled (normal receive operation) (Initial value) [Clearing conditions] <ul style="list-style-type: none"> • The MPIE bit is cleared to 0. • MPB = 1 in received data.
1	Multiprocessor interrupts are enabled* Receive-data-full interrupts (RXI), receive-error interrupts (ERI), and setting of the RDRF, FER, and ORER status flags in SSR are disabled until data with the multiprocessor bit set to 1 is received.

Note: * The SCI does not transfer receive data from RSR to RDR, does not detect receive errors, and does not set the RDRF, FER, and ORER flags in SSR. When it receives data in which MPB = 1, the SCI sets the MPB bit to 1 in SSR, automatically clears the MPIE bit to 0, enables RXI and ERI interrupts (if the RIE bit is set to 1 in SCR), and allows the FER and ORER flags to be set.

Bit 2—Transmit-End Interrupt Enable (TEIE): Enables or disables the transmit-end interrupt (TEI) requested if TDR does not contain new transmit data when the MSB is transmitted.

Bit 2: TEIE	Description
0	Transmit-end interrupt requests (TEI) are disabled* (Initial value)
1	Transmit-end interrupt requests (TEI) are enabled*

Note: * TEI interrupt requests can be cleared by reading the value 1 from the TDRE flag in SSR, then clearing the TDRE flag to 0, thereby also clearing the TEND flag to 0; or by clearing the TEIE bit to 0.

Bits 1 and 0—Clock Enable 1 and 0 (CKE1, CKE0): These bits select the SCI clock source and enable or disable clock output from the SCK pin. Depending on the settings of CKE1 and CKE0, the SCK pin can be used for generic input/output, serial clock output, or serial clock input.

The CKE0 setting is valid only in asynchronous mode, and only when the SCI is internally clocked (CKE1 = 0). The CKE0 setting is ignored in synchronous mode, or when an external clock source is selected (CKE1 = 1). Select the SCI operating mode in SMR before setting the CKE1 and CKE0 bits. For further details on selection of the SCI clock source, see table 13.9 in section 13.3, Operation.

Bit 1: CKE1	Bit 0: CKE0	Description	
0	0	Asynchronous mode	Internal clock, SCK pin available for generic input/output ^{*1}
		Synchronous mode	Internal clock, SCK pin used for serial clock output ^{*1}
	1	Asynchronous mode	Internal clock, SCK pin used for clock output ^{*2}
		Synchronous mode	Internal clock, SCK pin used for serial clock output
1	0	Asynchronous mode	External clock, SCK pin used for clock input ^{*3}
		Synchronous mode	External clock, SCK pin used for serial clock input
	1	Asynchronous mode	External clock, SCK pin used for clock input ^{*3}
		Synchronous mode	External clock, SCK pin used for serial clock input

- Notes:
1. Initial value
 2. The output clock frequency is the same as the bit rate.
 3. The input clock frequency is 16 times the bit rate.

13.2.7 Serial Status Register (SSR)

SSR is an 8-bit register containing multiprocessor bit values, and status flags that indicate SCI operating status.

Bit	7	6	5	4	3	2	1	0
	TDRE	RDRF	ORER	FER	PER	TEND	MPB	MPBT
Initial value	1	0	0	0	0	1	0	0
Read/Write	R/(W)*	R/(W)*	R/(W)*	R/(W)*	R/(W)*	R	R	R/W

								Multiprocessor bit transfer Value of multiprocessor bit to be transmitted
							Multiprocessor bit Stores the received multiprocessor bit value	
						Transmit end Status flag indicating end of transmission		
				Parity error Status flag indicating detection of a receive parity error				
			Framing error Status flag indicating detection of a receive framing error					
		Overrun error Status flag indicating detection of a receive overrun error						
	Receive data register full Status flag indicating that data has been received and stored in RDR							
	Transmit data register empty Status flag indicating that transmit data has been transferred from TDR into TSR and new data can be written in TDR							

Note: * Only 0 can be written, to clear the flag.

The CPU can always read and write SSR, but cannot write 1 in the TDRE, RDRF, ORER, PER, and FER flags. These flags can be cleared to 0 only if they have first been read while set to 1. The TEND and MPB flags are read-only bits that cannot be written.

SSR is initialized to H'84 by a reset and in standby mode.

Bit 7—Transmit Data Register Empty (TDRE): Indicates that the SCI has loaded transmit data from TDR into TSR and the next serial transmit data can be written in TDR.

Bit 7: TDRE	Description
0	TDR contains valid transmit data [Clearing conditions] <ul style="list-style-type: none"> • Software reads TDRE while it is set to 1, then writes 0. • The DMAC writes data in TDR.
1	TDR does not contain valid transmit data (Initial value) [Setting conditions] <ul style="list-style-type: none"> • The chip is reset or enters standby mode. • The TE bit in SCR is cleared to 0. • TDR contents are loaded into TSR, so new data can be written in TDR.

Bit 6—Receive Data Register Full (RDRF): Indicates that RDR contains new receive data.

Bit 6: RDRF	Description
0	RDR does not contain new receive data (Initial value) [Clearing conditions] <ul style="list-style-type: none"> • The chip is reset or enters standby mode. • Software reads RDRF while it is set to 1, then writes 0. • The DMAC reads data from RDR.
1	RDR contains new receive data [Setting condition] When serial data is received normally and transferred from RSR to RDR.

Note: The RDR contents and RDRF flag are not affected by detection of receive errors or by clearing of the RE bit to 0 in SCR. They retain their previous values. If the RDRF flag is still set to 1 when reception of the next data ends, an overrun error occurs and receive data is lost.

Bit 5—Overrun Error (ORER): Indicates that data reception ended abnormally due to an overrun error.

Bit 5: ORER	Description
0	Receiving is in progress or has ended normally (Initial value) ^{*1} [Clearing conditions] <ul style="list-style-type: none"> The chip is reset or enters standby mode. Software reads ORER while it is set to 1, then writes 0.
1	A receive overrun error occurred ^{*2} [Setting condition] Reception of the next serial data ends when RDRF = 1.

- Notes: 1. Clearing the RE bit to 0 in SCR does not affect the ORER flag, which retains its previous value.
2. RDR continues to hold the receive data before the overrun error, so subsequent receive data is lost. Serial receiving cannot continue while the ORER flag is set to 1. In synchronous mode, serial transmitting is also disabled.

Bit 4—Framing Error (FER): Indicates that data reception ended abnormally due to a framing error in asynchronous mode.

Bit 4: FER	Description
0	Receiving is in progress or has ended normally (Initial value) ^{*1} [Clearing conditions] <ul style="list-style-type: none"> The chip is reset or enters standby mode. Software reads FER while it is set to 1, then writes 0.
1	A receive framing error occurred ^{*2} [Setting condition] The stop bit at the end of receive data is checked and found to be 0.

- Notes: 1. Clearing the RE bit to 0 in SCR does not affect the FER flag, which retains its previous value.
2. When the stop bit length is 2 bits, only the first bit is checked. The second stop bit is not checked. When a framing error occurs the SCI transfers the receive data into RDR but does not set the RDRF flag. Serial receiving cannot continue while the FER flag is set to 1. In synchronous mode, serial transmitting is also disabled.

Bit 3—Parity Error (PER): Indicates that data reception ended abnormally due to a parity error in asynchronous mode.

Bit 3: PER	Description
0	Receiving is in progress or has ended normally* ¹ (Initial value) [Clearing conditions] <ul style="list-style-type: none"> The chip is reset or enters standby mode. Software reads PER while it is set to 1, then writes 0.
1	A receive parity error occurred* ² [Setting condition] <p>The number of 1s in receive data, including the parity bit, does not match the even or odd parity setting of O/\bar{E} in SMR.</p>

- Notes:
- Clearing the RE bit to 0 in SCR does not affect the PER flag, which retains its previous value.
 - When a parity error occurs the SCI transfers the receive data into RDR but does not set the RDRF flag. Serial receiving cannot continue while the PER flag is set to 1. In synchronous mode, serial transmitting is also disabled.

Bit 2—Transmit End (TEND): Indicates that when the last bit of a serial character was transmitted TDR did not contain new transmit data, so transmission has ended. The TEND flag is a read-only bit and cannot be written.

Bit 2: TEND	Description
0	Transmission is in progress [Clearing conditions] <ul style="list-style-type: none"> Software reads TDRE while it is set to 1, then writes 0 in the TDRE flag. The DMAC writes data in TDR.
1	End of transmission (Initial value) [Setting conditions] <ul style="list-style-type: none"> The chip is reset or enters standby mode. The TE bit is cleared to 0 in SCR. TDRE is 1 when the last bit of a serial character is transmitted.

Bit 1—Multiprocessor Bit (MPB): Stores the value of the multiprocessor bit in receive data when a multiprocessor format is used in asynchronous mode. MPB is a read-only bit and cannot be written.

Bit 1: MPB	Description
0	Multiprocessor bit value in receive data is 0* (Initial value)
1	Multiprocessor bit value in receive data is 1

Note: * If the RE bit is cleared to 0 when a multiprocessor format is selected, MPB retains its previous value.

Bit 0—Multiprocessor Bit Transfer (MPBT): Stores the value of the multiprocessor bit added to transmit data when a multiprocessor format is selected for transmitting in asynchronous mode. The MPBT setting is ignored in synchronous mode, when a multiprocessor format is not selected, or when the SCI is not transmitting.

Bit 0: MPBT	Description
0	Multiprocessor bit value in transmit data is 0 (Initial value)
1	Multiprocessor bit value in transmit data is 1

13.2.8 Bit Rate Register (BRR)

BRR is an 8-bit register that, together with the CKS1 and CKS0 bits in SMR that select the baud rate generator clock source, determines the serial communication bit rate.

Bit	7	6	5	4	3	2	1	0
Initial value	1	1	1	1	1	1	1	1
Read/Write	R/W	R/W	R/W	R/W	R/W	R/W	R/W	R/W

The CPU can always read and write BRR. BRR is initialized to H'FF by a reset and in standby mode. The two SCI channels have independent baud rate generator control, so different values can be set in the two channels.

Table 13.3 shows examples of BRR settings in asynchronous mode. Table 13.4 shows examples of BRR settings in synchronous mode.

Table 13.3 Examples of Bit Rates and BRR Settings in Asynchronous Mode

Bit Rate (bits/s)	ϕ (MHz)											
	2			2.097152			2.4576			3		
	n	N	Error (%)	n	N	Error (%)	n	N	Error (%)	n	N	Error (%)
110	1	141	0.03	1	148	-0.04	1	174	-0.26	1	212	0.03
150	1	103	0.16	1	108	0.21	1	127	0.00	1	155	0.16
300	0	207	0.16	0	217	0.21	0	255	0.00	1	77	0.16
600	0	103	0.16	0	108	0.21	0	127	0.00	0	155	0.16
1200	0	51	0.16	0	54	-0.70	0	63	0.00	0	77	0.16
2400	0	25	0.16	0	26	1.14	0	31	0.00	0	38	0.16
4800	0	12	0.16	0	13	-2.48	0	15	0.00	0	19	-2.34
9600	0	6	-6.99	0	6	-2.48	0	7	0.00	0	9	-2.34
19200	0	2	8.51	0	2	13.78	0	3	0.00	0	4	-2.34
31250	0	1	0.00	0	1	4.86	0	1	22.88	0	2	0.00
38400	0	1	-18.62	0	1	-14.67	0	1	0.00	0	1	22.07

Bit Rate (bits/s)	ϕ (MHz)											
	3.6864			4			4.9152			5		
	n	N	Error (%)	n	N	Error (%)	n	N	Error (%)	n	N	Error (%)
110	2	64	0.70	2	70	0.03	2	86	0.31	2	88	-0.25
150	1	191	0.00	1	207	0.16	1	255	0.00	2	64	0.16
300	1	95	0.00	1	103	0.16	1	127	0.00	1	129	0.16
600	0	191	0.00	0	207	0.16	0	255	0.00	1	64	0.16
1200	0	95	0.00	0	103	0.16	0	127	0.00	0	129	0.16
2400	0	47	0.00	0	51	0.16	0	63	0.00	0	64	0.16
4800	0	23	0.00	0	25	0.16	0	31	0.00	0	32	-1.36
9600	0	11	0.00	0	12	0.16	0	15	0.00	0	15	1.73
19200	0	5	0.00	0	6	-6.99	0	7	0.00	0	7	1.73
31250	0	3	-7.84	0	3	0.00	0	4	-1.70	0	4	0.00
38400	0	2	0.00	0	2	8.51	0	3	0.00	0	3	1.73

Bit Rate (bits/s)	ϕ (MHz)											
	6			6.144			7.3728			8		
	n	N	Error (%)	n	N	Error (%)	n	N	Error (%)	n	N	Error (%)
110	2	106	-0.44	2	108	0.08	2	130	-0.07	2	141	0.03
150	2	77	0.16	2	79	0.00	2	95	0.00	2	103	0.16
300	1	155	0.16	1	159	0.00	1	191	0.00	1	207	0.16
600	1	77	0.16	1	79	0.00	1	95	0.00	1	103	0.16
1200	0	155	0.16	0	159	0.00	0	191	0.00	0	207	0.16
2400	0	77	0.16	0	79	0.00	0	95	0.00	0	103	0.16
4800	0	38	0.16	0	39	0.00	0	47	0.00	0	51	0.16
9600	0	19	-2.34	0	19	0.00	0	23	0.00	0	25	0.16
19200	0	9	-2.34	0	9	0.00	0	11	0.00	0	12	0.16
31250	0	5	0.00	0	5	2.40	0	6	5.33	0	7	0.00
38400	0	4	-2.34	0	4	0.00	0	5	0.00	0	6	-6.99

Bit Rate (bits/s)	ϕ (MHz)											
	9.8304			10			12			12.288		
	n	N	Error (%)	n	N	Error (%)	n	N	Error (%)	n	N	Error (%)
110	2	174	-0.26	2	177	-0.25	2	212	0.03	2	217	0.08
150	2	127	0.00	2	129	0.16	2	155	0.16	2	159	0.00
300	1	255	0.00	2	64	0.16	2	77	0.16	2	79	0.00
600	1	127	0.00	1	129	0.16	1	155	0.16	1	159	0.00
1200	0	255	0.00	1	64	0.16	1	77	0.16	1	79	0.00
2400	0	127	0.00	0	129	0.16	0	155	0.16	0	159	0.00
4800	0	63	0.00	0	64	0.16	0	77	0.16	0	79	0.00
9600	0	31	0.00	0	32	-1.36	0	38	0.16	0	39	0.00
19200	0	15	0.00	0	15	1.73	0	19	-2.34	0	19	0.00
31250	0	9	-1.70	0	9	0.00	0	11	0.00	0	11	2.40
38400	0	7	0.00	0	7	1.73	0	9	-2.34	0	9	0.00

Bit Rate (bits/s)	ϕ (MHz)											
	13			14			14.7456			16		
	n	N	Error (%)	n	N	Error (%)	n	N	Error (%)	n	N	Error (%)
110	2	230	-0.08	2	248	-0.17	3	64	0.70	3	70	0.03
150	2	168	0.16	2	181	0.16	2	191	0.00	2	207	0.16
300	2	84	-0.43	2	90	0.16	2	95	0.00	2	103	0.16
600	1	168	0.16	1	181	0.16	1	191	0.00	1	207	0.16
1200	1	84	-0.43	1	90	0.16	1	95	0.00	1	103	0.16
2400	0	168	0.16	0	181	0.16	0	191	0.00	0	207	0.16
4800	0	84	-0.43	0	90	0.16	0	95	0.00	0	103	0.16
9600	0	41	0.76	0	45	-0.93	0	47	0.00	0	51	0.16
19200	0	20	0.76	0	22	-0.93	0	23	0.00	0	25	0.16
31250	0	12	0.00	0	13	0.00	0	14	-1.70	0	15	0.00
38400	0	10	-3.82	0	10	3.57	0	11	0.00	0	12	0.16

Bit Rate (bits/s)	ϕ (MHz)								
	18			20			25		
	n	N	Error (%)	n	N	Error (%)	n	N	Error (%)
110	3	79	-0.12	3	88	-0.25	3	110	-0.02
150	2	233	0.16	3	64	0.16	3	80	0.47
300	2	116	0.16	2	129	0.16	2	162	-0.15
600	1	233	0.16	2	64	0.16	2	80	0.47
1200	1	116	0.16	1	129	0.16	1	162	-0.15
2400	0	233	0.16	1	64	0.16	1	80	0.47
4800	0	116	0.16	0	129	0.16	0	162	-0.15
9600	0	58	-0.69	0	64	0.16	0	80	0.47
19200	0	28	1.02	0	32	-1.36	0	40	-0.76
31250	0	17	0.00	0	19	0.00	0	24	0.00
38400	0	14	-2.34	0	15	1.73	0	19	1.73

Table 13.4 Examples of Bit Rates and BRR Settings in Synchronous Mode

Bit Rate (bits/s)	ϕ (MHz)																	
	2		4		8		10		13		16		18		20		25	
	n	N	n	N	n	N	n	N	n	N	n	N	n	N	n	N	n	N
110	3	70	—	—	—	—	—	—	—	—	—	—	—	—	—	—	—	—
250	2	124	2	249	3	124	—	—	3	202	3	249	—	—	—	—	—	—
500	1	249	2	124	2	249	—	—	3	101	3	124	3	140	3	155	—	—
1 k	1	124	1	249	2	124	—	—	2	202	2	249	3	69	3	77	3	97
2.5 k	0	199	1	99	1	199	1	249	2	80	2	99	2	112	2	124	2	155
5 k	0	99	0	199	1	99	1	124	1	162	1	199	1	224	1	249	2	77
10 k	0	49	0	99	0	199	0	249	1	80	1	99	1	112	1	124	1	155
25 k	0	19	0	39	0	79	0	99	0	129	0	159	0	179	0	199	0	249
50 k	0	9	0	19	0	39	0	49	0	64	0	79	0	89	0	99	0	124
100 k	0	4	0	9	0	19	0	24	—	—	0	39	0	44	0	49	0	62
250 k	0	1	0	3	0	7	0	9	0	12	0	15	0	17	0	19	0	24
500 k	0	0*	0	1	0	3	0	4	—	—	0	7	0	8	0	9	—	—
1 M			0	0*	0	1	—	—	—	—	0	3	0	4	0	4	—	—
2 M					0	0*	—	—	—	—	0	1	—	—	—	—	—	—
2.5 M					—	—	0	0*	—	—	—	—	—	—	—	—	—	—
4 M											0	0*	—	—	—	—	—	—

Legend:

Blank: No setting available

—: Setting possible, but error occurs

*: Continuous transmit/receive not possible

Note: Settings with an error of 1% or less are recommended.

The BRR setting is calculated as follows:

Asynchronous mode:

$$N = \frac{\phi}{64 \times 2^{2n-1} \times B} \times 10^6 - 1$$

Synchronous mode:

$$N = \frac{\phi}{8 \times 2^{2n-1} \times B} \times 10^6 - 1$$

B: Bit rate (bits/s)

N: BRR setting for baud rate generator ($0 \leq N \leq 255$)

ϕ : System clock frequency (MHz)

n: Baud rate generator clock source ($n = 0, 1, 2, 3$)

(For the clock sources and values of n, see the following table.)

n	Clock Source	SMR Settings	
		CKS1	CKS0
0	ϕ	0	0
1	$\phi/4$	0	1
2	$\phi/16$	1	0
3	$\phi/64$	1	1

The bit rate error in asynchronous mode is calculated as follows.

$$\text{Error (\%)} = \left\{ \frac{\phi \times 10^6}{(N + 1) \times B \times 64 \times 2^{2n-1}} - 1 \right\} \times 100$$

Table 13.5 indicates the maximum bit rates in asynchronous mode for various system clock frequencies. Tables 13.6 and 13.7 indicate the maximum bit rates with external clock input.

Table 13.5 Maximum Bit Rates for Various Frequencies (Asynchronous Mode)

ϕ (MHz)	Maximum Bit Rate (bits/s)	Settings	
		n	N
2	62500	0	0
2.097152	65536	0	0
2.4576	76800	0	0
3	93750	0	0
3.6864	115200	0	0
4	125000	0	0
4.9152	153600	0	0
5	156250	0	0
6	187500	0	0
6.144	192000	0	0
7.3728	230400	0	0
8	250000	0	0
9.8304	307200	0	0
10	312500	0	0
12	375000	0	0
12.288	384000	0	0
14	437500	0	0
14.7456	460800	0	0
16	500000	0	0
17.2032	537600	0	0
18	562500	0	0
20	625000	0	0
25	781250	0	0

Table 13.6 Maximum Bit Rates with External Clock Input (Asynchronous Mode)

ϕ (MHz)	External Input Clock (MHz)	Maximum Bit Rate (bits/s)
2	0.5000	31250
2.097152	0.5243	32768
2.4576	0.6144	38400
3	0.7500	46875
3.6864	0.9216	57600
4	1.0000	62500
4.9152	1.2288	76800
5	1.2500	78125
6	1.5000	93750
6.144	1.5360	96000
7.3728	1.8432	115200
8	2.0000	125000
9.8304	2.4576	153600
10	2.5000	156250
12	3.0000	187500
12.288	3.0720	192000
14	3.5000	218750
14.7456	3.6864	230400
16	4.0000	250000
17.2032	4.3008	268800
18	4.5000	281250
20	5.0000	312500
25	6.2500	390625

Table 13.7 Maximum Bit Rates with External Clock Input (Synchronous Mode)

ϕ (MHz)	External Input Clock (MHz)	Maximum Bit Rate (bits/s)
2	0.3333	333333.3
4	0.6667	666666.7
6	1.0000	1000000.0
8	1.3333	1333333.3
10	1.6667	1666666.7
12	2.0000	2000000.0
14	2.3333	2333333.3
16	2.6667	2666666.7
18	3.0000	3000000.0
20	3.3333	3333333.3
25	4.1667	4166666.7

13.3 Operation

13.3.1 Overview

The SCI has an asynchronous mode in which characters are synchronized individually, and a synchronous mode in which communication is synchronized with clock pulses. Serial communication is possible in either mode. Asynchronous or synchronous mode and the communication format are selected in SMR, as shown in table 13.8. The SCI clock source is selected by the C/\bar{A} bit in SMR and the CKE1 and CKE0 bits in SCR, as shown in table 13.9.

Asynchronous Mode:

- Data length is selectable: 7 or 8 bits.
- Parity and multiprocessor bits are selectable. So is the stop bit length (1 or 2 bits). These selections determine the communication format and character length.
- In receiving, it is possible to detect framing errors, parity errors, overrun errors, and the break state.
- An internal or external clock can be selected as the SCI clock source.
 - When an internal clock is selected, the SCI operates using the on-chip baud rate generator, and can output a serial clock signal with a frequency matching the bit rate.
 - When an external clock is selected, the external clock input must have a frequency 16 times the bit rate. (The on-chip baud rate generator is not used.)

Synchronous Mode:

- The communication format has a fixed 8-bit data length.
- In receiving, it is possible to detect overrun errors.
- An internal or external clock can be selected as the SCI clock source.
 - When an internal clock is selected, the SCI operates using the on-chip baud rate generator, and outputs a serial clock signal to external devices.
 - When an external clock is selected, the SCI operates on the input serial clock. The on-chip baud rate generator is not used.

Table 13.8 SMR Settings and Serial Communication Formats

SMR Settings						SCI Communication Format			
Bit 7: C/ \bar{A}	Bit 6: CHR	Bit 2: MP	Bit 5: PE	Bit 3: STOP	Mode	Data Length	Multi- processor Bit	Parity Bit	Stop Bit Length
0	0	0	0	0	Asynchronous mode	8-bit data	Absent	Absent	1 bit
				1					2 bits
				0					1 bit
				1					2 bits
				0					1 bit
				1					2 bits
	1	0	0	0	Asynchronous mode (multi- processor format)	7-bit data	Absent	Absent	1 bit
				1					2 bits
				0					1 bit
				1					2 bits
				0					1 bit
				1					2 bits
0	1	—	0	Asynchronous mode (multi- processor format)	8-bit data	Present	Absent	1 bit	
			1					2 bits	
1	—	—	0	Asynchronous mode (multi- processor format)	7-bit data	Present	Absent	1 bit	
			1					2 bits	
1	—	—	—	—	Synchronous mode	8-bit data	Absent	None	

Table 13.9 SMR and SCR Settings and SCI Clock Source Selection

SMR	SCR Settings			SCI Transmit/Receive Clock		
Bit 7: C/ \bar{A}	Bit 1: CKE1	Bit 0: CKE0	Mode	Clock Source	SCK Pin Function	
0	0	0	Asynchronous mode	Internal	SCI does not use the SCK pin	
		1				Outputs a clock with frequency matching the bit rate
		0			External	Inputs a clock with frequency 16 times the bit rate
		1				
1	0	0	Synchronous mode	Internal	Outputs the serial clock	
		1				
		0			External	Inputs the serial clock
		1				

Communication Formats

Table 13.10 shows the 12 communication formats that can be selected in asynchronous mode. The format is selected by settings in SMR.

Table 13.10 Serial Communication Formats (Asynchronous Mode)

SMR Settings				Serial Communication Format and Frame Length												
CHR	PE	MP	STOP	1	2	3	4	5	6	7	8	9	10	11	12	
0	0	0	0	S	8-bit data								STOP			
0	0	0	1	S	8-bit data								STOP	STOP		
0	1	0	0	S	8-bit data								P	STOP		
0	1	0	1	S	8-bit data								P	STOP	STOP	
1	0	0	0	S	7-bit data							STOP				
1	0	0	1	S	7-bit data							STOP	STOP			
1	1	0	0	S	7-bit data							P	STOP			
1	1	0	1	S	7-bit data							P	STOP	STOP		
0	—	1	0	S	8-bit data								MPB	STOP		
0	—	1	1	S	8-bit data								MPB	STOP	STOP	
1	—	1	0	S	7-bit data							MPB	STOP			
1	—	1	1	S	7-bit data							MPB	STOP	STOP		

Legend:

S: Start bit

STOP: Stop bit

P: Parity bit

MPB: Multiprocessor bit

Clock

An internal clock generated by the on-chip baud rate generator or an external clock input from the SCK pin can be selected as the SCI transmit/receive clock. The clock source is selected by the C/\bar{A} bit in SMR and bits CKE1 and CKE0 in SCR. See table 13.9.

When an external clock is input at the SCK pin, it must have a frequency equal to 16 times the desired bit rate.

When the SCI operates on an internal clock, it can output a clock signal at the SCK pin. The frequency of this output clock is equal to the bit rate. The phase is aligned as in figure 13.3 so that the rising edge of the clock occurs at the center of each transmit data bit.

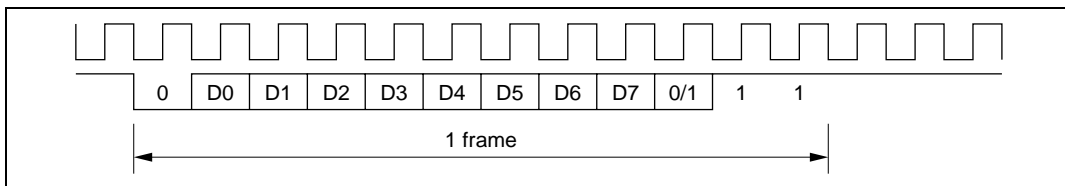

**Figure 13.3 Phase Relationship between Output Clock and Serial Data
(Asynchronous Mode)**

Transmitting and Receiving Data

SCI Initialization (Asynchronous Mode): Before transmitting or receiving, clear the TE and RE bits to 0 in SCR, then initialize the SCI as follows.

When changing the communication mode or format, always clear the TE and RE bits to 0 before following the procedure given below. Clearing TE to 0 sets the TDRE flag to 1 and initializes TSR. Clearing RE to 0, however, does not initialize the RDRF, PER, FER, and ORER flags and RDR, which retain their previous contents.

When an external clock is used, the clock should not be stopped during initialization or subsequent operation. SCI operation becomes unreliable if the clock is stopped.

Figure 13.4 is a sample flowchart for initializing the SCI.

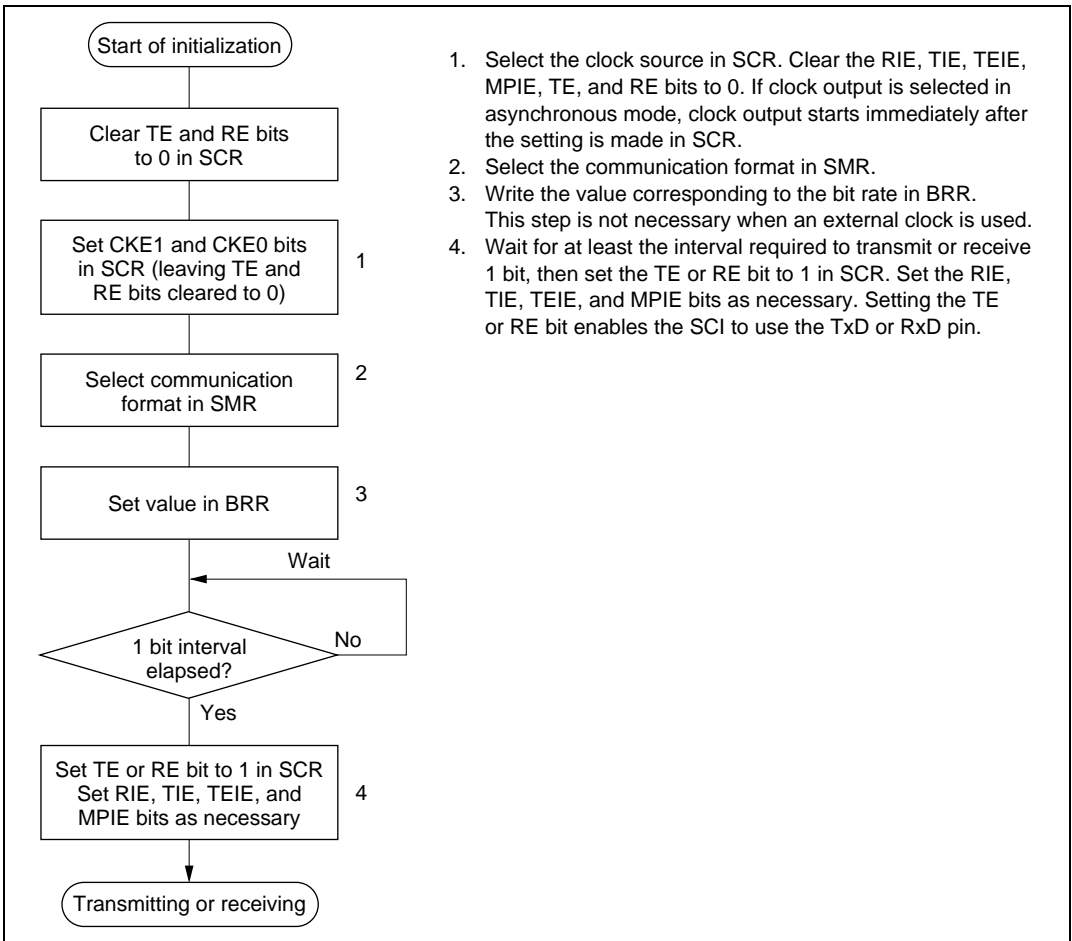

Figure 13.4 Sample Flowchart for SCI Initialization

Transmitting Serial Data (Asynchronous Mode): Figure 13.5 shows a sample flowchart for transmitting serial data and indicates the procedure to follow.

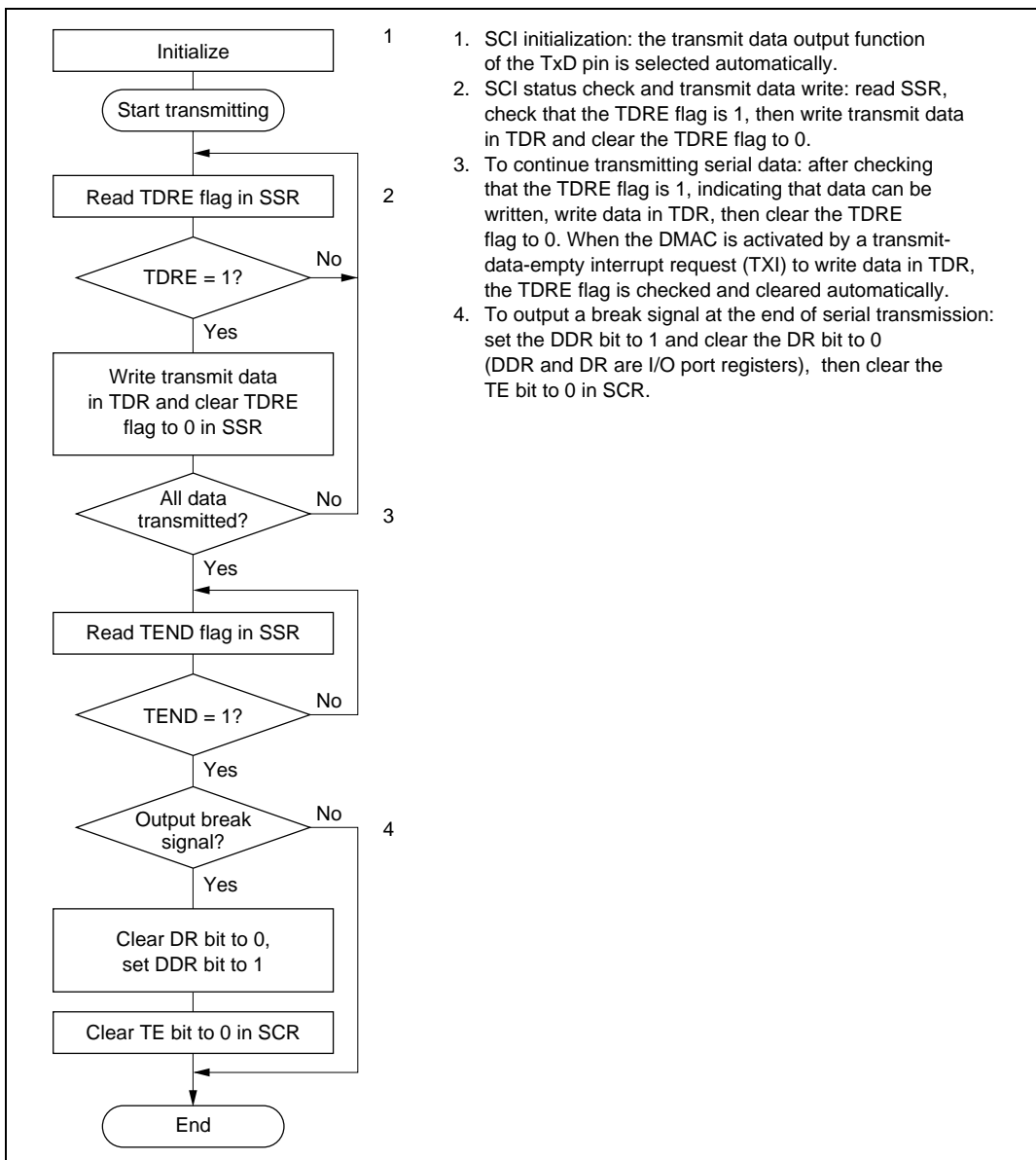

Figure 13.5 Sample Flowchart for Transmitting Serial Data

In transmitting serial data, the SCI operates as follows.

1. The SCI monitors the TDRE flag in SSR. When the TDRE flag is cleared to 0 the SCI recognizes that TDR contains new data, and loads this data from TDR into TSR.
2. After loading the data from TDR into TSR, the SCI sets the TDRE flag to 1 and starts transmitting. If the TIE bit is set to 1 in SCR, the SCI requests a transmit-data-empty interrupt (TXI) at this time.
Serial transmit data is transmitted in the following order from the TxD pin:
 - a. Start bit: One 0 bit is output.
 - b. Transmit data: 7 or 8 bits are output, LSB first.
 - c. Parity bit or multiprocessor bit: One parity bit (even or odd parity) or one multiprocessor bit is output. Formats in which neither a parity bit nor a multiprocessor bit is output can also be selected.
 - d. Stop bit: One or two 1 bits (stop bits) are output.
 - e. Mark state: Output of 1 bits continues until the start bit of the next transmit data.
3. The SCI checks the TDRE flag when it outputs the stop bit. If the TDRE flag is 0, the SCI loads new data from TDR into TSR, outputs the stop bit, then begins serial transmission of the next frame. If the TDRE flag is 1, the SCI sets the TEND flag to 1 in SSR, outputs the stop bit, then continues output of 1 bits in the mark state. If the TEIE bit is set to 1 in SCR, a transmit-end interrupt (TEI) is requested at this time.

Figure 13.6 shows an example of SCI transmit operation in asynchronous mode.

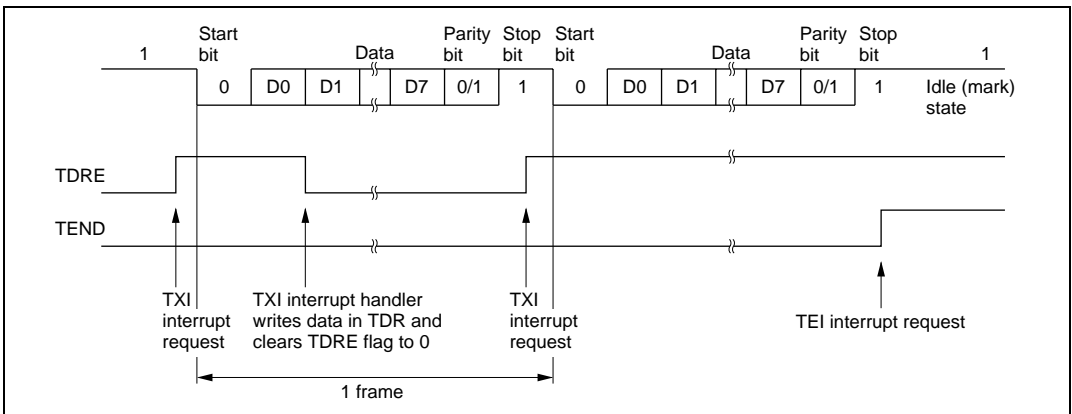
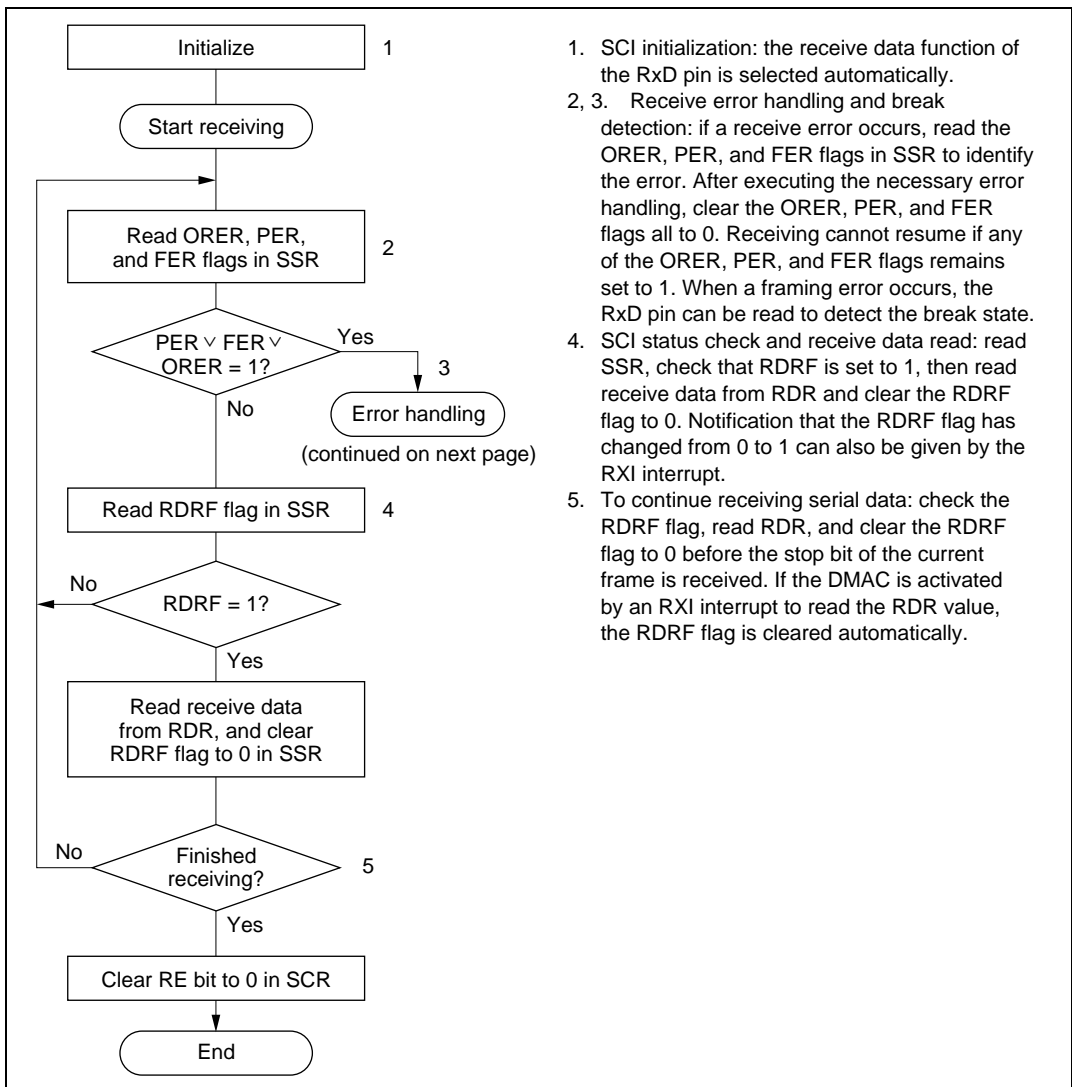

Figure 13.6 Example of SCI Transmit Operation in Asynchronous Mode (8-Bit Data with Parity and 1 Stop Bit)

Receiving Serial Data (Asynchronous Mode): Figure 13.7 shows a sample flowchart for receiving serial data and indicates the procedure to follow.



1. SCI initialization: the receive data function of the RxD pin is selected automatically.
- 2, 3. Receive error handling and break detection: if a receive error occurs, read the ORER, PER, and FER flags in SSR to identify the error. After executing the necessary error handling, clear the ORER, PER, and FER flags all to 0. Receiving cannot resume if any of the ORER, PER, and FER flags remains set to 1. When a framing error occurs, the RxD pin can be read to detect the break state.
4. SCI status check and receive data read: read SSR, check that RDRF is set to 1, then read receive data from RDR and clear the RDRF flag to 0. Notification that the RDRF flag has changed from 0 to 1 can also be given by the RXI interrupt.
5. To continue receiving serial data: check the RDRF flag, read RDR, and clear the RDRF flag to 0 before the stop bit of the current frame is received. If the DMAC is activated by an RXI interrupt to read the RDR value, the RDRF flag is cleared automatically.

Figure 13.7 Sample Flowchart for Receiving Serial Data (1)

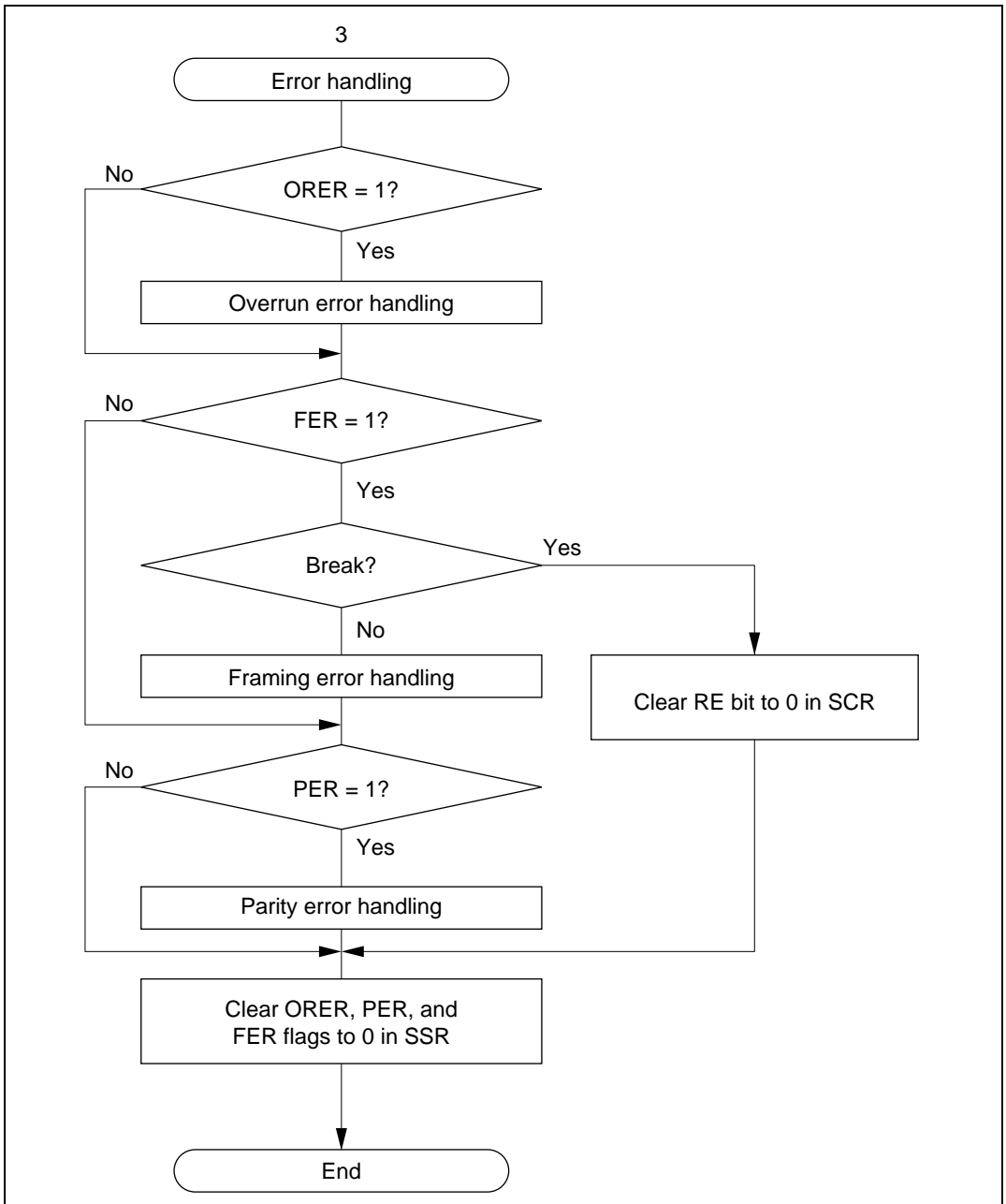

Figure 13.7 Sample Flowchart for Receiving Serial Data (2)

In receiving, the SCI operates as follows.

1. The SCI monitors the receive data line. When it detects a start bit, the SCI synchronizes internally and starts receiving.
2. Receive data is stored in RSR in order from LSB to MSB.
3. The parity bit and stop bit are received.

After receiving, the SCI makes the following checks:

- a. Parity check: The number of 1s in the receive data must match the even or odd parity setting of the O/E bit in SMR.
- b. Stop bit check: The stop bit value must be 1. If there are two stop bits, only the first stop bit is checked.
- c. Status check: The RDRF flag must be 0 so that receive data can be transferred from RSR into RDR.

If these checks all pass, the RDRF flag is set to 1 and the received data is stored in RDR. If one of the checks fails (receive error)*, the SCI operates as indicated in table 13.11.

Note: * When a receive error occurs, further receiving is disabled. In receiving, the RDRF flag is not set to 1. Be sure to clear the error flags to 0.

4. When the RDRF flag is set to 1, if the RIE bit is set to 1 in SCR, a receive-data-full interrupt (RXI) is requested. If the ORER, PER, or FER flag is set to 1 and the RIE bit in SCR is also set to 1, a receive-error interrupt (ERI) is requested.

Table 13.11 Receive Error Conditions

Receive Error	Abbreviation	Condition	Data Transfer
Overrun error	ORER	Receiving of next data ends while RDRF flag is still set to 1 in SSR	Receive data not transferred from RSR to RDR
Framing error	FER	Stop bit is 0	Receive data transferred from RSR to RDR
Parity error	PER	Parity of receive data differs from even/odd parity setting in SMR	Receive data transferred from RSR to RDR

Figure 13.8 shows an example of SCI receive operation in asynchronous mode.

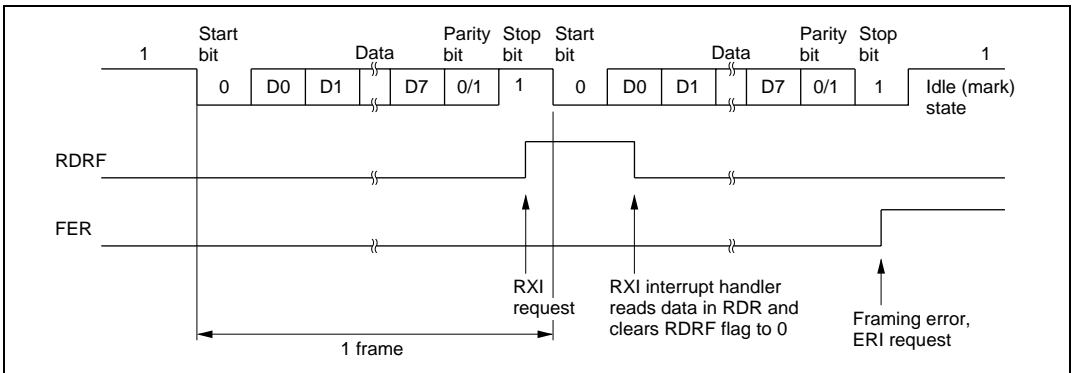

Figure 13.8 Example of SCI Receive Operation (8-Bit Data with Parity and One Stop Bit)

13.3.3 Multiprocessor Communication

The multiprocessor communication function enables several processors to share a single serial communication line. The processors communicate in asynchronous mode using a format with an additional multiprocessor bit (multiprocessor format).

In multiprocessor communication, each receiving processor is addressed by an ID. A serial communication cycle consists of an ID-sending cycle that identifies the receiving processor, and a data-sending cycle. The multiprocessor bit distinguishes ID-sending cycles from data-sending cycles.

The transmitting processor starts by sending the ID of the receiving processor with which it wants to communicate as data with the multiprocessor bit set to 1. Next the transmitting processor sends transmit data with the multiprocessor bit cleared to 0.

Receiving processors skip incoming data until they receive data with the multiprocessor bit set to 1. When they receive data with the multiprocessor bit set to 1, receiving processors compare the data with their IDs. The receiving processor with a matching ID continues to receive further incoming data. Processors with IDs not matching the received data skip further incoming data until they again receive data with the multiprocessor bit set to 1. Multiple processors can send and receive data in this way.

Figure 13.9 shows an example of communication among different processors using a multiprocessor format.

Communication Formats

Four formats are available. Parity-bit settings are ignored when a multiprocessor format is selected. For details see table 13.10.

Clock

See the description of asynchronous mode.

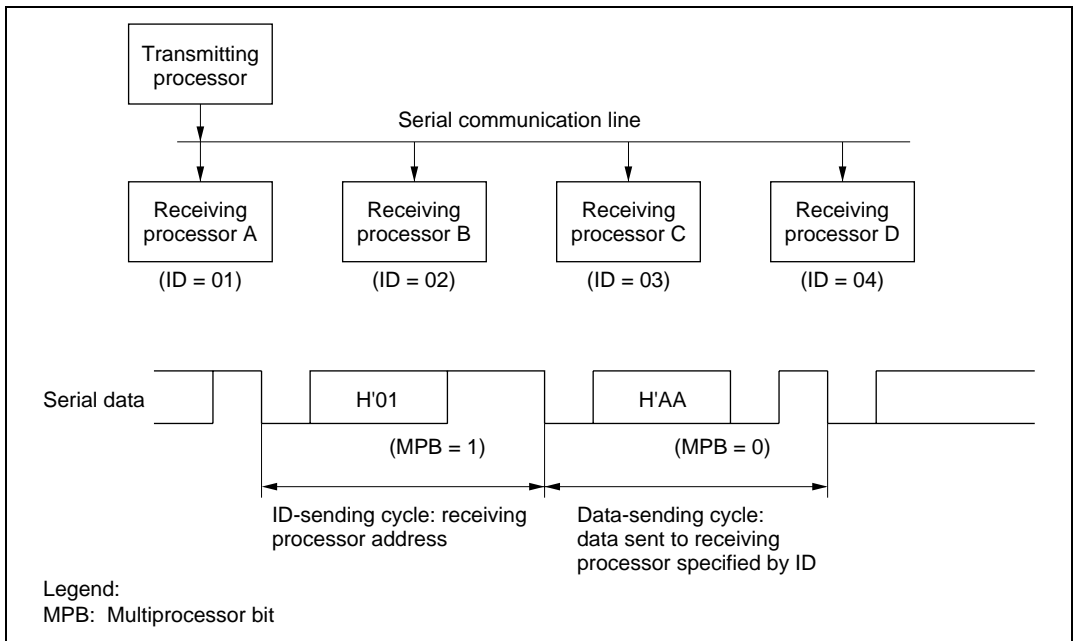

Figure 13.9 Example of Communication among Processors Using Multiprocessor Format (Sending Data H'AA to Receiving Processor A)

Transmitting and Receiving Data

Transmitting Multiprocessor Serial Data: Figure 13.10 shows a sample flowchart for transmitting multiprocessor serial data and indicates the procedure to follow.

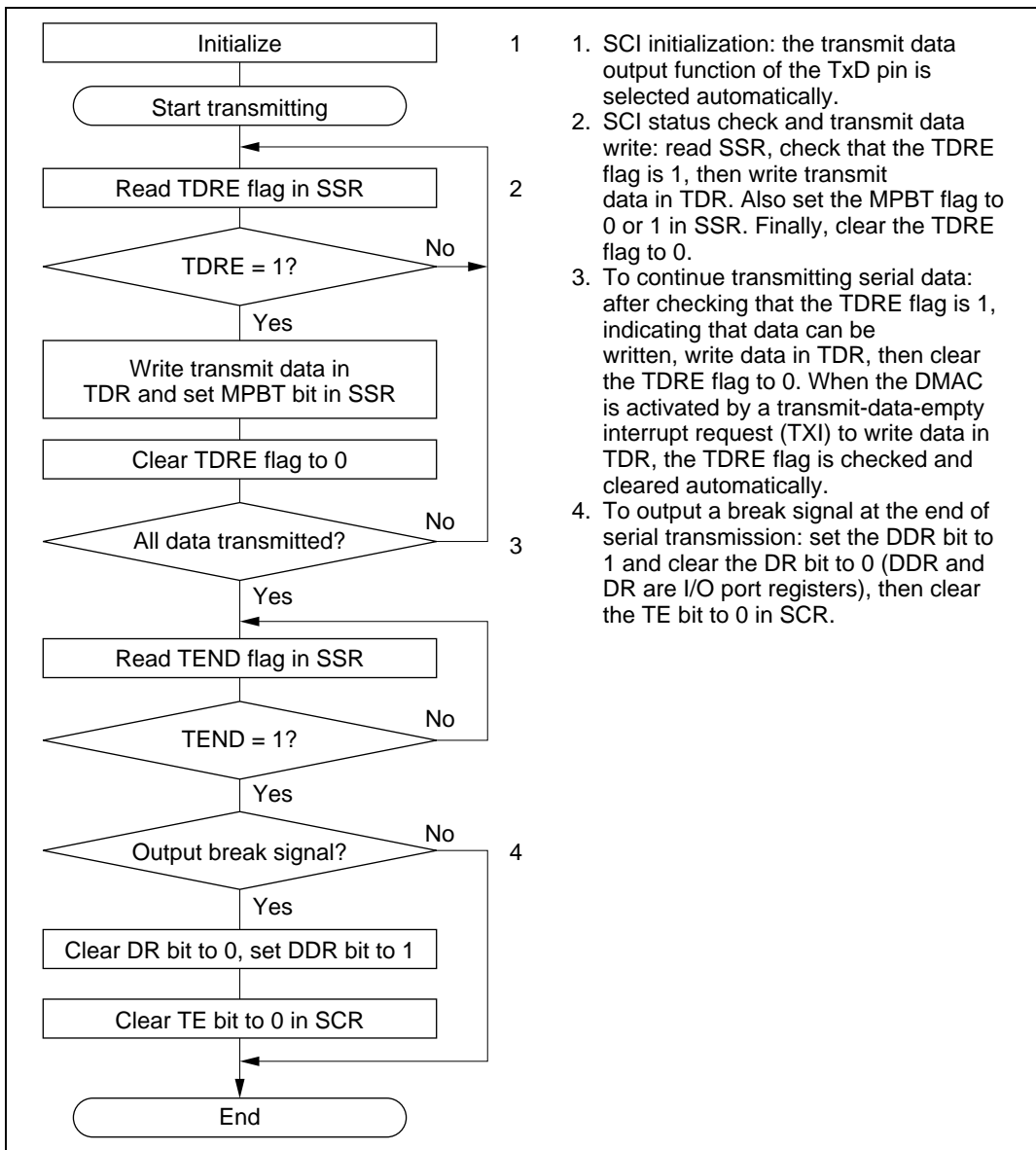

Figure 13.10 Sample Flowchart for Transmitting Multiprocessor Serial Data

In transmitting serial data, the SCI operates as follows.

1. The SCI monitors the TDRE flag in SSR. When the TDRE flag is cleared to 0 the SCI recognizes that TDR contains new data, and loads this data from TDR into TSR.
2. After loading the data from TDR into TSR, the SCI sets the TDRE flag to 1 and starts transmitting. If the TIE bit in SCR is set to 1, the SCI requests a transmit-data-empty interrupt (TXI) at this time.

Serial transmit data is transmitted in the following order from the TxD pin:

- a. Start bit: One 0 bit is output.
 - b. Transmit data: 7 or 8 bits are output, LSB first.
 - c. Multiprocessor bit: One multiprocessor bit (MPBT value) is output.
 - d. Stop bit: One or two 1 bits (stop bits) are output.
 - e. Mark state: Output of 1 bits continues until the start bit of the next transmit data.
3. The SCI checks the TDRE flag when it outputs the stop bit. If the TDRE flag is 0, the SCI loads data from TDR into TSR, outputs the stop bit, then begins serial transmission of the next frame. If the TDRE flag is 1, the SCI sets the TEND flag in SSR to 1, outputs the stop bit, then continues output of 1 bits in the mark state. If the TEIE bit is set to 1 in SCR, a transmit-end interrupt (TEI) is requested at this time.

Figure 13.11 shows an example of SCI transmit operation using a multiprocessor format.

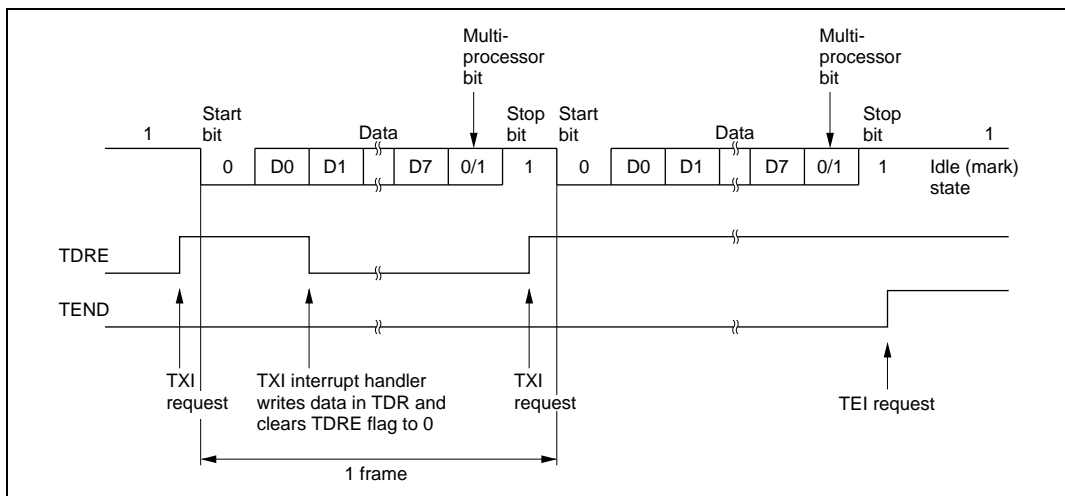

**Figure 13.11 Example of SCI Transmit Operation
(8-Bit Data with Multiprocessor Bit and One Stop Bit)**

Receiving Multiprocessor Serial Data: Figure 13.12 shows a sample flowchart for receiving multiprocessor serial data and indicates the procedure to follow.

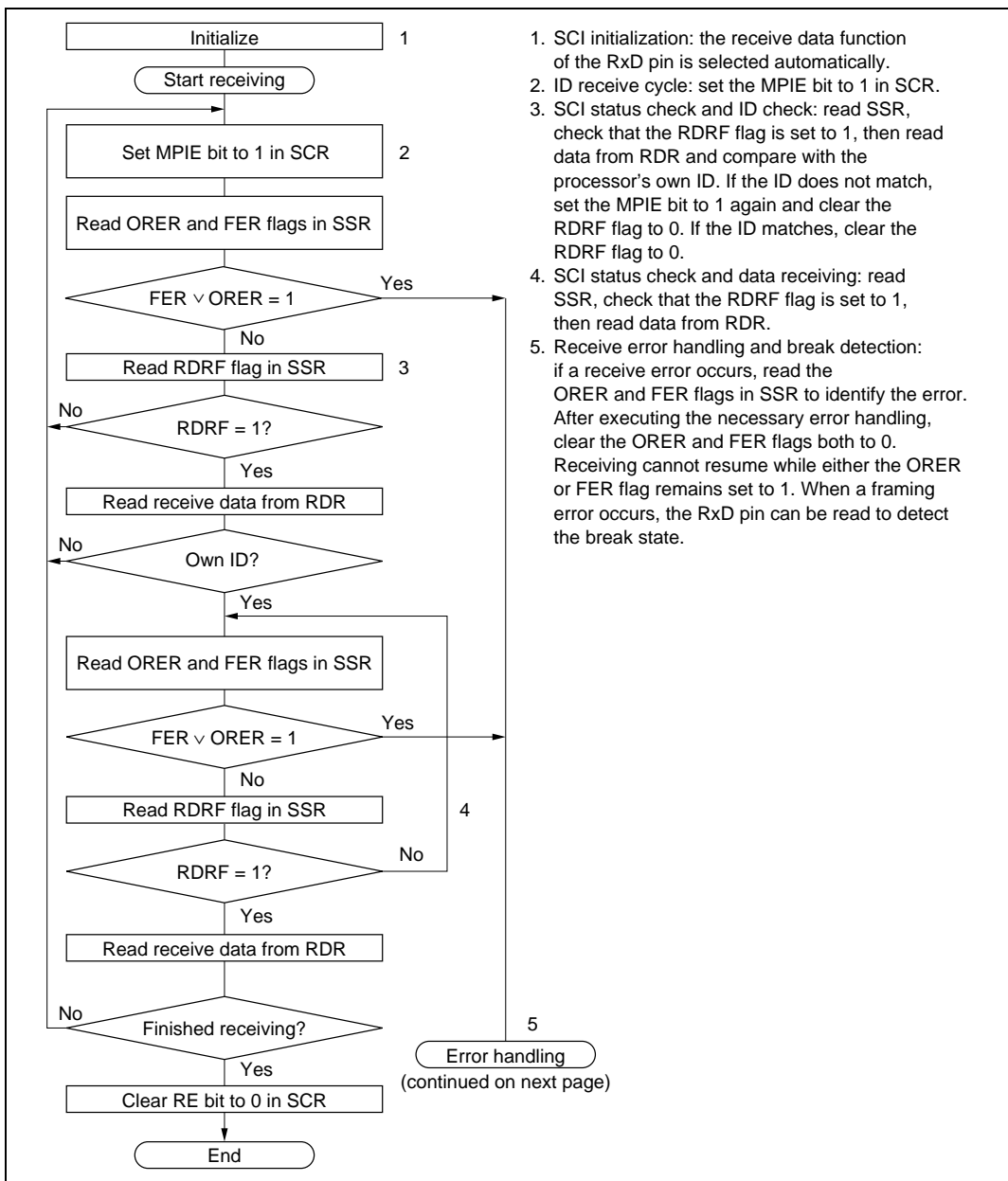

Figure 13.12 Sample Flowchart for Receiving Multiprocessor Serial Data (1)

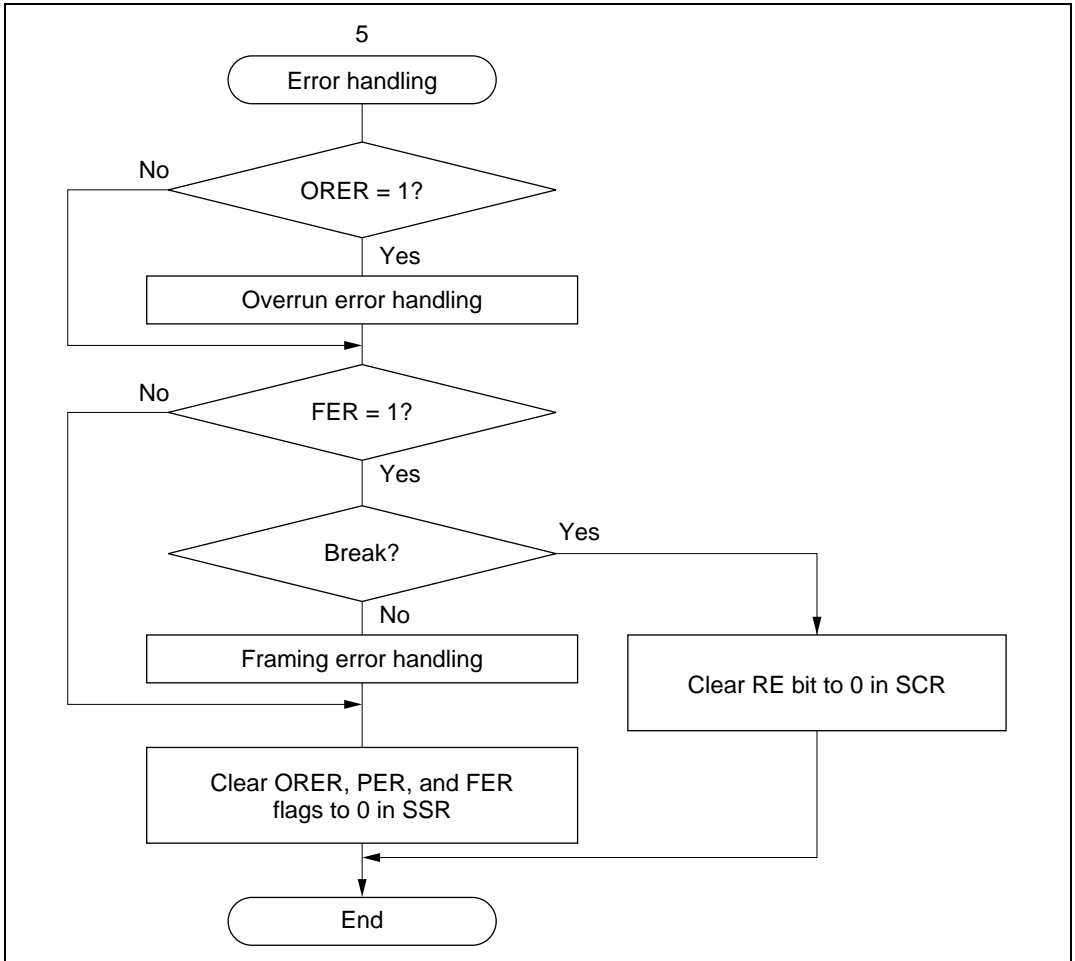

Figure 13.12 Sample Flowchart for Receiving Multiprocessor Serial Data (2)

Figure 13.13 shows an example of SCI receive operation using a multiprocessor format.

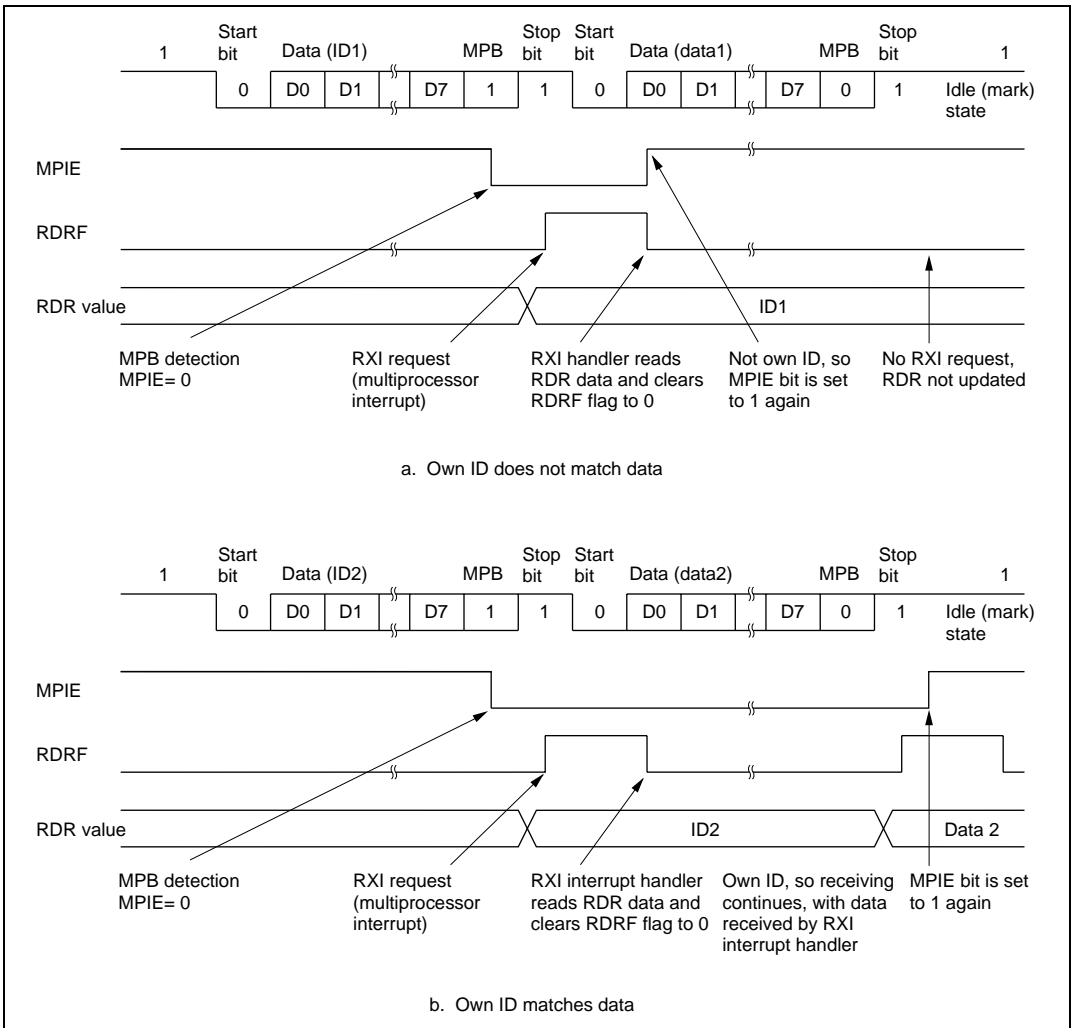

Figure 13.13 Example of SCI Receive Operation (8-Bit Data with Multiprocessor Bit and One Stop Bit)

13.3.4 Synchronous Operation

In synchronous mode, the SCI transmits and receives data in synchronization with clock pulses. This mode is suitable for high-speed serial communication.

The SCI transmitter and receiver share the same clock but are otherwise independent, so full duplex communication is possible. The transmitter and receiver are also double buffered, so continuous transmitting or receiving is possible by reading or writing data while transmitting or receiving is in progress.

Figure 13.14 shows the general format in synchronous serial communication.

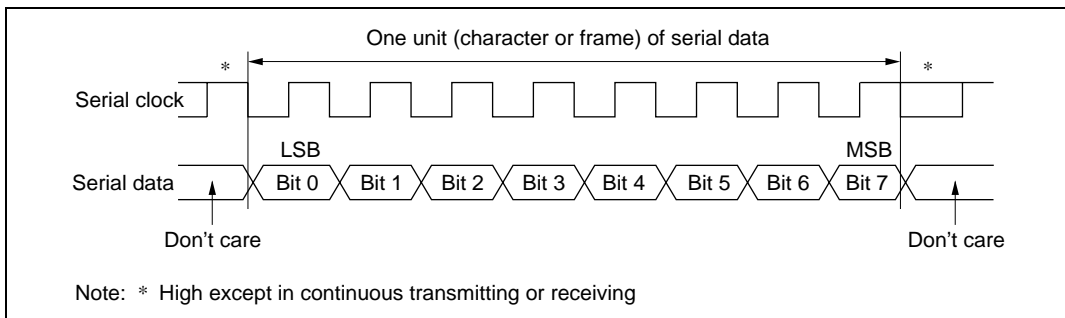

Figure 13.14 Data Format in Synchronous Communication

In synchronous serial communication, each data bit is placed on the communication line from one falling edge of the serial clock to the next. Data is guaranteed valid at the rise of the serial clock. In each character, the serial data bits are transmitted in order from LSB (first) to MSB (last). After output of the MSB, the communication line remains in the state of the MSB. In synchronous mode the SCI receives data by synchronizing with the rise of the serial clock.

Communication Format

The data length is fixed at 8 bits. No parity bit or multiprocessor bit can be added.

Clock

An internal clock generated by the on-chip baud rate generator or an external clock input from the SCK pin can be selected by setting the $\overline{C/A}$ bit in SMR and the CKE1 and CKE0 bits in SCR. See table 13.9. When the SCI operates on an internal clock, it outputs the clock signal at the SCK pin. Eight clock pulses are output per transmitted or received character.

When the SCI operates on an internal clock, the serial clock outputs the clock signal at the SCK pin. Eight clock pulses are output per transmitted or received character. When the SCI is not transmitting or receiving, the clock signal remains in the high state. However, when receiving only, overrun error may occur or the serial clock continues output until the RE bit clears at 0. When transmitting or receiving in single characters, select the external clock.

Transmitting and Receiving Data

SCI Initialization (Synchronous Mode): Before transmitting or receiving, clear the TE and RE bits to 0 in SCR, then initialize the SCI as follows.

When changing the communication mode or format, always clear the TE and RE bits to 0 before following the procedure given below. Clearing the TE bit to 0 sets the TDRE flag to 1 and initializes TSR. Clearing the RE bit to 0, however, does not initialize the RDRF, PER, FER, and ORE flags and RDR, which retain their previous contents.

Figure 13.15 is a sample flowchart for initializing the SCI.

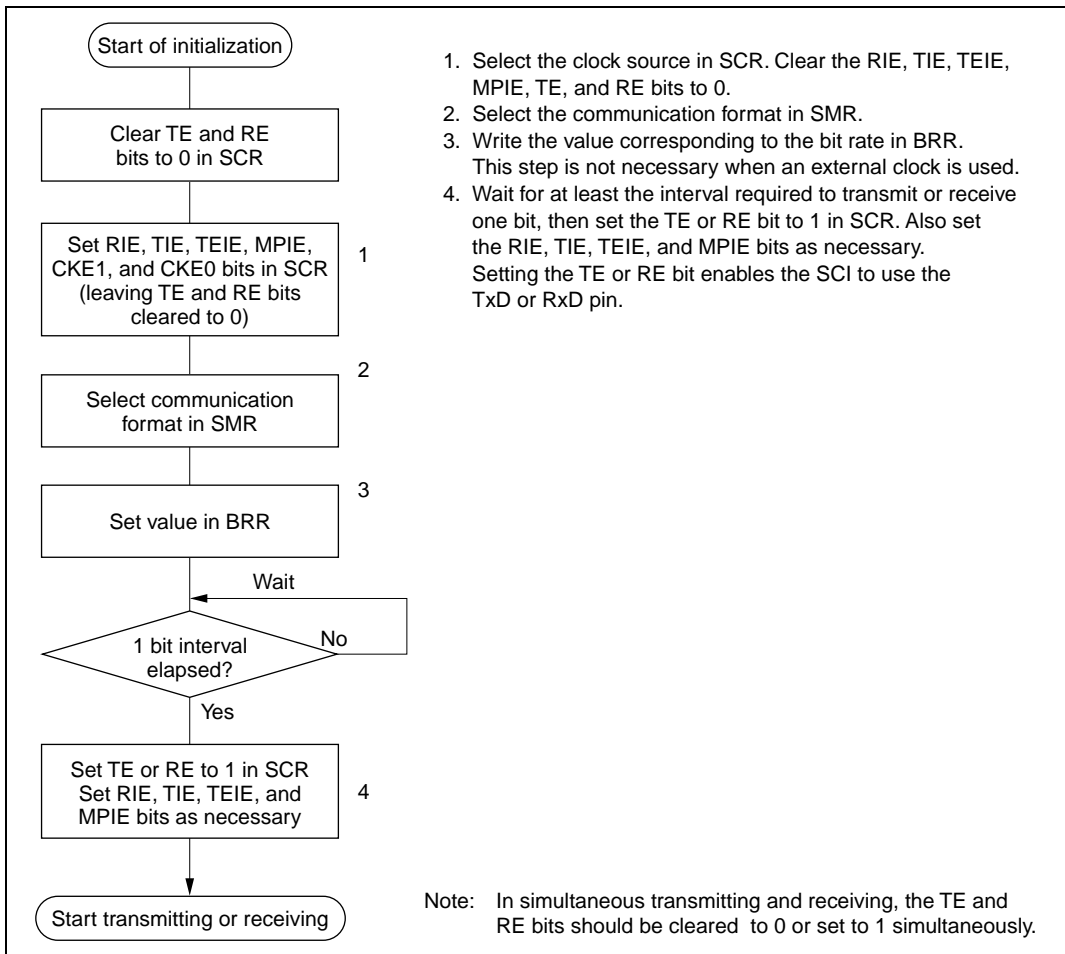

Figure 13.15 Sample Flowchart for SCI Initialization

Transmitting Serial Data (Synchronous Mode): Figure 13.16 shows a sample flowchart for transmitting serial data and indicates the procedure to follow.

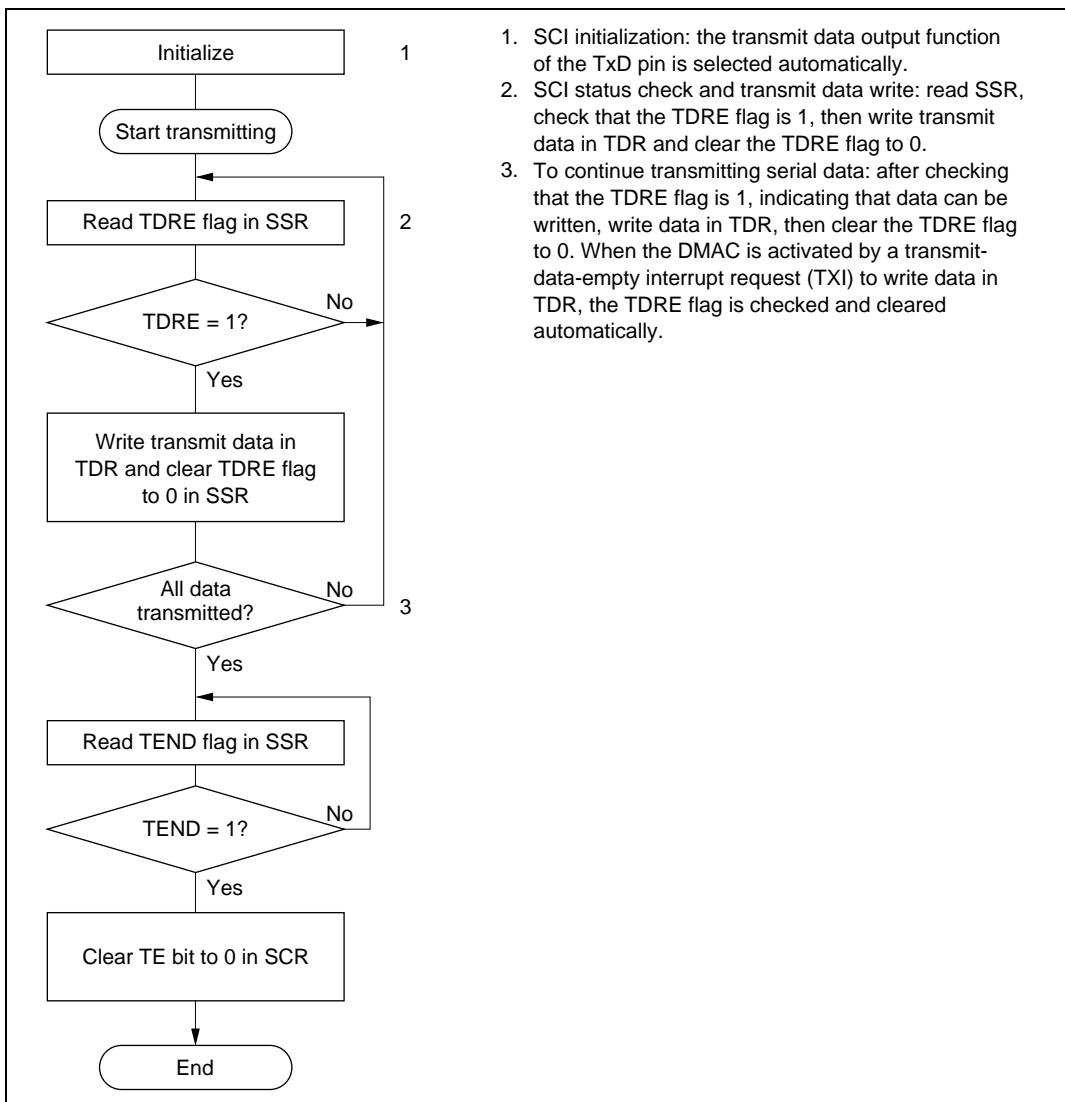

Figure 13.16 Sample Flowchart for Serial Transmitting

In transmitting serial data, the SCI operates as follows.

1. The SCI monitors the TDRE flag in SSR. When the TDRE flag is cleared to 0 the SCI recognizes that TDR contains new data, and loads this data from TDR into TSR.
2. After loading the data from TDR into TSR, the SCI sets the TDRE flag to 1 and starts transmitting. If the TIE bit is set to 1 in SCR, the SCI requests a transmit-data-empty interrupt (TXI) at this time.
If clock output is selected, the SCI outputs eight serial clock pulses. If an external clock source is selected, the SCI outputs data in synchronization with the input clock. Data is output from the TxD pin in order from LSB (bit 0) to MSB (bit 7).
3. The SCI checks the TDRE flag when it outputs the MSB (bit 7). If the TDRE flag is 0, the SCI loads data from TDR into TSR and begins serial transmission of the next frame. If the TDRE flag is 1, the SCI sets the TEND flag to 1 in SSR, and after transmitting the MSB, holds the TxD pin in the MSB state. If the TEIE bit in SCR is set to 1, a transmit-end interrupt (TEI) is requested at this time.
4. After the end of serial transmission, the SCK pin is held in a constant state.

Figure 13.17 shows an example of SCI transmit operation.

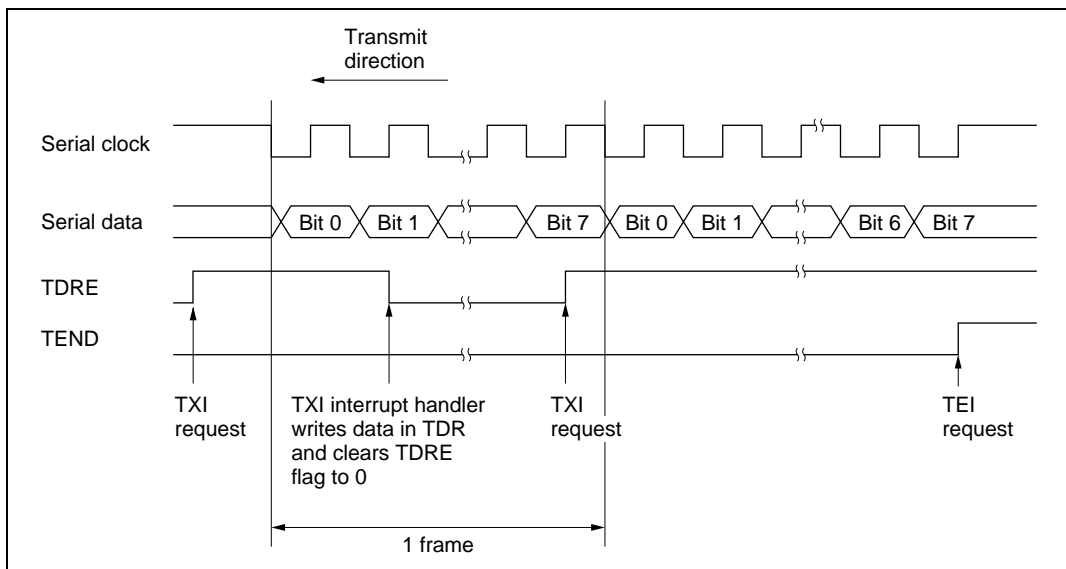

Figure 13.17 Example of SCI Transmit Operation

Receiving Serial Data: Figure 13.18 shows a sample flowchart for receiving serial data and indicates the procedure to follow. When switching from asynchronous mode to synchronous mode, make sure that the ORER, PER, and FER flags are cleared to 0. If the FER or PER flag is set to 1 the RDRF flag will not be set and both transmitting and receiving will be disabled.

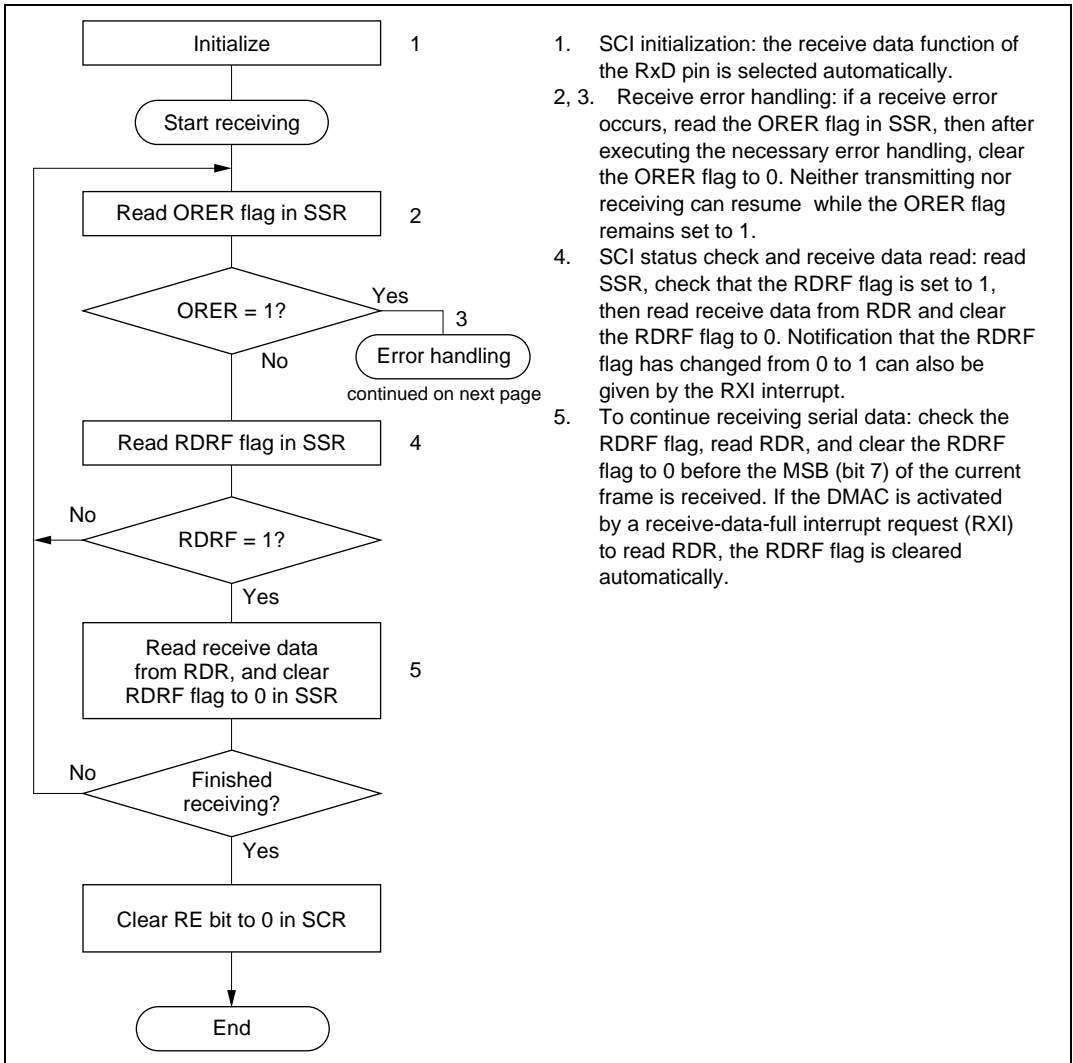

Figure 13.18 Sample Flowchart for Serial Receiving (1)

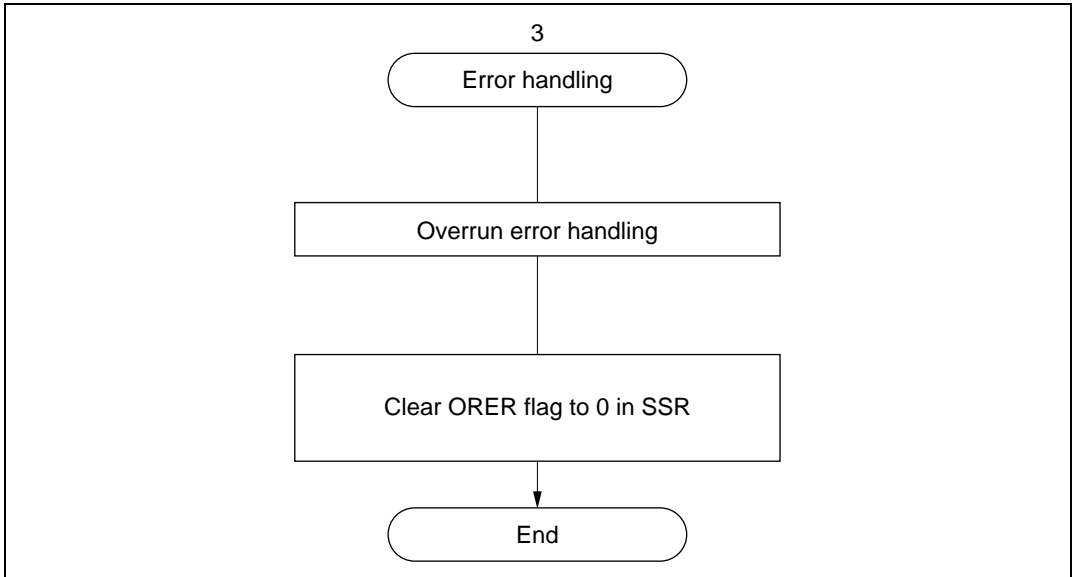

Figure 13.18 Sample Flowchart for Serial Receiving (2)

In receiving, the SCI operates as follows.

1. The SCI synchronizes with serial clock input or output and initializes internally.
2. Receive data is stored in RSR in order from LSB to MSB.
After receiving the data, the SCI checks that the RDRF flag is 0 so that receive data can be transferred from RSR to RDR. If this check passes, the RDRF flag is set to 1 and the received data is stored in RDR. If the check does not pass (receive error), the SCI operates as indicated in table 13.11.
3. After setting the RDRF flag to 1, if the RIE bit is set to 1 in SCR, the SCI requests a receive-data-full interrupt (RXI). If the ORER flag is set to 1 and the RIE bit in SCR is also set to 1, the SCI requests a receive-error interrupt (ERI).

Figure 13.19 shows an example of SCI receive operation.

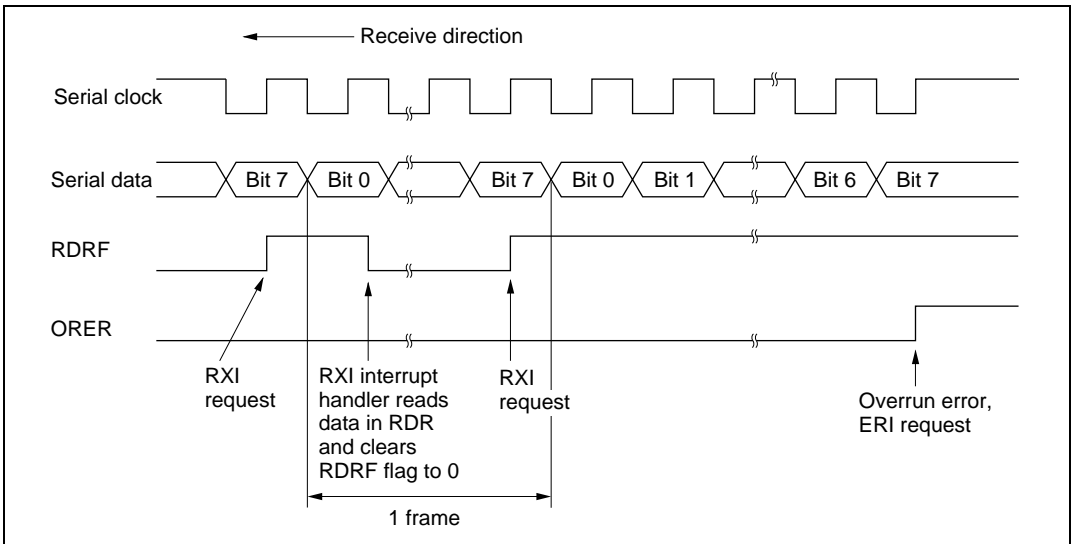

Figure 13.19 Example of SCI Receive Operation

Transmitting and Receiving Serial Data Simultaneously (Synchronous Mode): Figure 13.20 shows a sample flowchart for transmitting and receiving serial data simultaneously and indicates the procedure to follow.

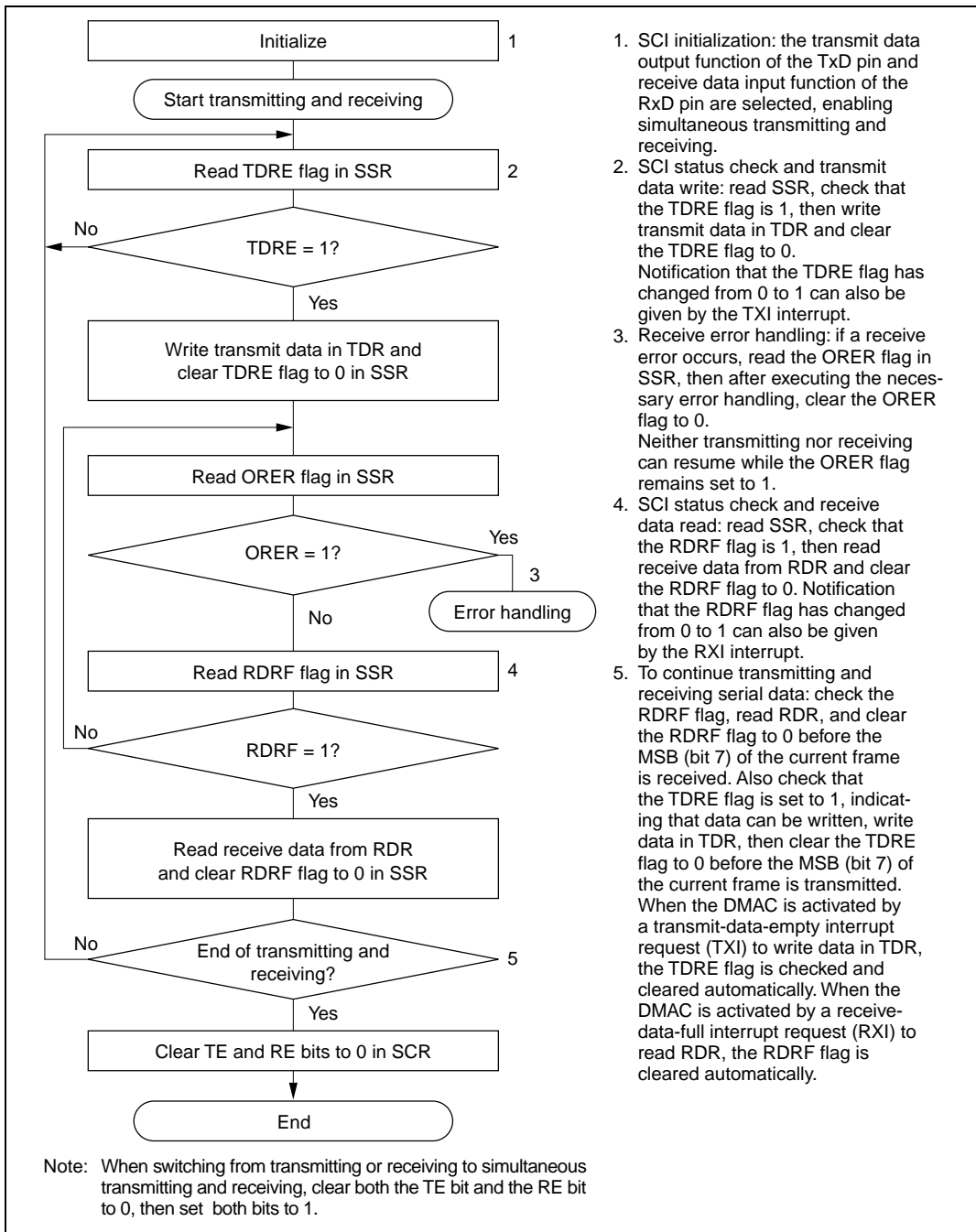

Figure 13.20 Sample Flowchart for Serial Transmitting

13.4 SCI Interrupts

The SCI has four interrupt request sources: TEI (transmit-end interrupt), ERI (receive-error interrupt), RXI (receive-data-full interrupt), and TXI (transmit-data-empty interrupt). Table 13.12 lists the interrupt sources and indicates their priority. These interrupts can be enabled and disabled by the TIE, TEIE, and RIE bits in SCR. Each interrupt request is sent separately to the interrupt controller.

The TXI interrupt is requested when the TDRE flag is set to 1 in SSR. The TEI interrupt is requested when the TEND flag is set to 1 in SSR. The TXI interrupt request can activate the DMAC to transfer data. Data transfer by the DMAC automatically clears the TDRE flag to 0. The TEI interrupt request cannot activate the DMAC.

The RXI interrupt is requested when the RDRF flag is set to 1 in SSR. The ERI interrupt is requested when the ORER, PER, or FER flag is set to 1 in SSR. The RXI interrupt request can activate the DMAC to transfer data. Data transfer by the DMAC automatically clears the RDRF flag to 0. The ERI interrupt request cannot activate the DMAC.

The DMAC can be activated by interrupts from SCI channel 0.

Table 13.12 SCI Interrupt Sources

Interrupt	Description	Priority
ERI	Receive error (ORER, FER, or PER)	High
RXI	Receive data register full (RDRF)	↑ Low
TXI	Transmit data register empty (TDRE)	
TEI	Transmit end (TEND)	

13.5 Usage Notes

Note the following points when using the SCI.

TDR Write and TDRE Flag

The TDRE flag in SSR is a status flag indicating the loading of transmit data from TDR into TSR. The SCI sets the TDRE flag to 1 when it transfers data from TDR to TSR.

Data can be written into TDR regardless of the state of the TDRE flag. If new data is written in TDR when the TDRE flag is 0, the old data stored in TDR will be lost because this data has not yet been transferred to TSR. Before writing transmit data in TDR, be sure to check that the TDRE flag is set to 1.

Simultaneous Multiple Receive Errors

Table 13.13 indicates the state of SSR status flags when multiple receive errors occur simultaneously. When an overrun error occurs the RSR contents are not transferred to RDR, so receive data is lost.

Table 13.13 SSR Status Flags and Transfer of Receive Data

SSR Status Flags				Receive Data Transfer RSR → RDR	Receive Errors
RDRF	ORER	FER	PER		
1	1	0	0	×	Overrun error
0	0	1	0	O	Framing error
0	0	0	1	O	Parity error
1	1	1	0	×	Overrun error + framing error
1	1	0	1	×	Overrun error + parity error
0	0	1	1	O	Framing error + parity error
1	1	1	1	×	Overrun error + framing error + parity error

Legend:

O: Receive data is transferred from RSR to RDR.

×: Receive data is not transferred from RSR to RDR.

Break Detection and Processing

Break signals can be detected by reading the RxD pin directly when a framing error (FER) is detected. In the break state the input from the RxD pin consists of all 0s, so the FER flag is set and the parity error flag (PER) may also be set. In the break state the SCI receiver continues to operate, so if the FER flag is cleared to 0 it will be set to 1 again.

Sending a Break Signal

When the TE bit is cleared to 0 the TxD pin becomes an I/O port, the level and direction (input or output) of which are determined by DR and DDR bits. This feature can be used to send a break signal.

After the serial transmitter is initialized, the DR value substitutes for the mark state until the TE bit is set to 1 (the TxD pin function is not selected until the TE bit is set to 1). The DDR and DR bits should therefore both be set to 1 beforehand.

To send a break signal during serial transmission, clear the DR bit to 0, then clear the TE bit to 0. When the TE bit is cleared to 0 the transmitter is initialized, regardless of its current state, so the TxD pin becomes an output port outputting the value 0.

Receive Error Flags and Transmitter Operation (Synchronous Mode Only)

When a receive error flag (ORER, PER, or FER) is set to 1 the SCI will not start transmitting, even if the TDRE flag is cleared to 0. Be sure to clear the receive error flags to 0 when starting to transmit. Note that clearing the RE bit to 0 does not clear the receive error flags to 0.

Receive Data Sampling Timing in Asynchronous Mode and Receive Margin

In asynchronous mode the SCI operates on a base clock with 16 times the bit rate frequency. In receiving, the SCI synchronizes internally with the fall of the start bit, which it samples on the base clock. Receive data is latched at the rising edge of the eighth base clock pulse. See figure 13.21.

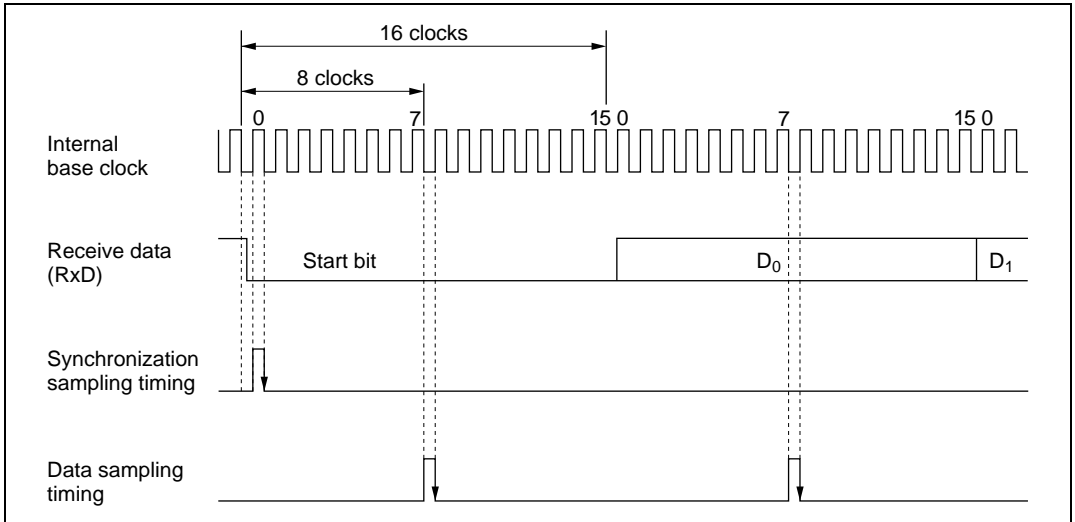

Figure 13.21 Receive Data Sampling Timing in Asynchronous Mode

The receive margin in asynchronous mode can therefore be expressed as in equation (1).

$$M = \left| \left(0.5 - \frac{1}{2N} \right) - (L - 0.5) F - \frac{|D - 0.5|}{N} (1 + F) \right| \times 100\% \dots\dots\dots (1)$$

- M: Receive margin (%)
- N: Ratio of clock frequency to bit rate ($N = 16$)
- D: Clock duty cycle ($D = 0$ to 1.0)
- L: Frame length ($L = 9$ to 12)
- F: Absolute deviation of clock frequency

From equation (1), if $F = 0$ and $D = 0.5$ the receive margin is 46.875%, as given by equation (2).

$$\begin{aligned} D &= 0.5, F = 0 \\ M &= \{0.5 - 1/(2 \times 16)\} \times 100\% \\ &= 46.875\% \dots\dots\dots (2) \end{aligned}$$

This is a theoretical value. A reasonable margin to allow in system designs is 20% to 30%.

Restrictions on Usage of DMAC

To have the DMAC read RDR, be sure to select the SCI receive-data-full interrupt (RXI) as the activation source with bits DTS2 to DTS0 in DTCR.

Restrictions on Usage of the Serial Clock

When transmitting data using an external clock as the serial clock, an interval of at least 5 states is necessary between clearing the TDRE bit in SSR and the start (falling edge) of the first transmit clock pulse corresponding to each frame (see figure 13.22). This condition is also needed for continuous transmission. If it is not fulfilled, operational error will occur.

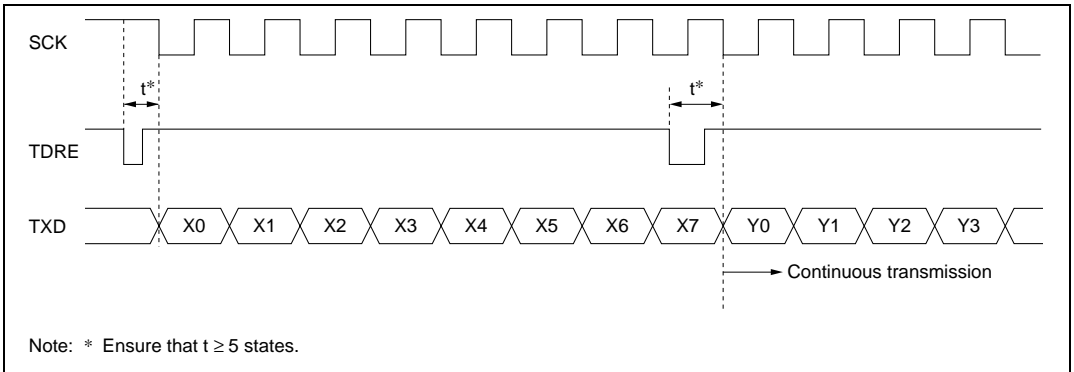

Figure 13.22 Serial Clock Transmission (Example)

Switching SCK Pin to Port Output Pin in Synchronous Mode

When the SCK pin is used as the serial clock output in synchronous mode, and is then switched to its output port function at the end of transmission, a low level may be output for one half-cycle. Half-cycle low-level output occurs when SCK is switched to its port function with the following settings when $DDR = 1$, $DR = 1$, $C/\bar{A} = 1$, $CKE1 = 0$, $CKE0 = 0$, and $TE = 1$.

1. End of serial data transmission
2. $TE = 0$
3. C/\bar{A} bit = 0 ... switchover to port output
4. Occurrence of low-level output (see figure 13.23)

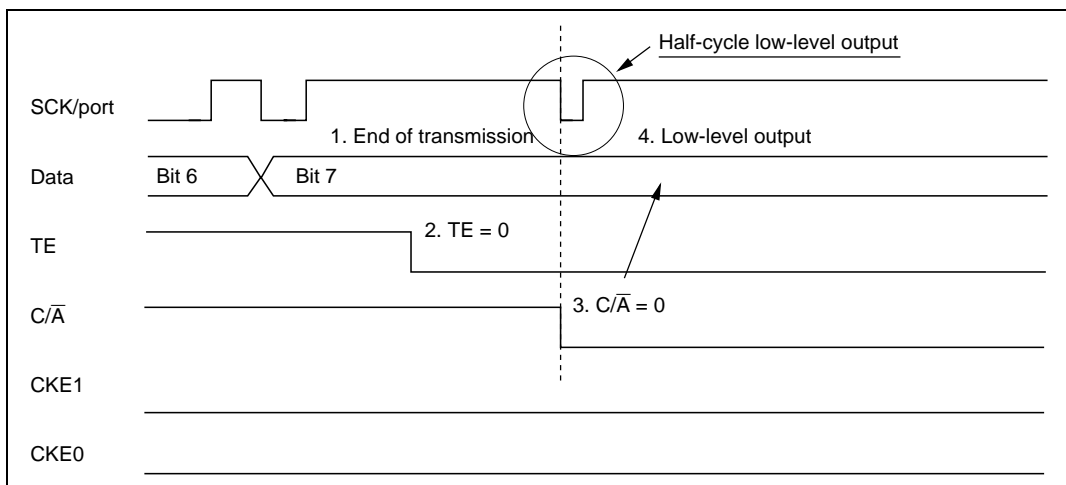

Figure 13.23 Operation when Switching from SCK Pin to Port Pin

Sample Procedure for Preventing Low-Level Output

As this sample procedure temporarily places the SCK pin in the input state, the SCK/port pin should be pulled up beforehand with an external circuit.

With $DDR = 1$, $DR = 1$, $C/\bar{A} = 1$, $CKE1 = 0$, $CKE0 = 0$, and $TE = 1$, make the following settings in the order shown.

1. End of serial data transmission
2. TE bit = 0
3. $CKE1$ bit = 1
4. C/\bar{A} bit = 0 ... switchover to port output
5. $CKE1$ bit = 0

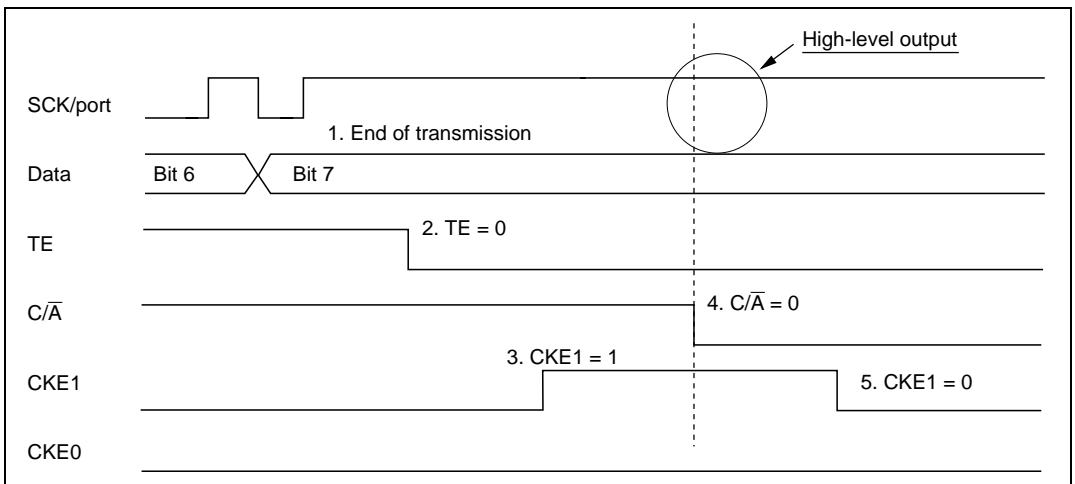

**Figure 13.24 Operation when Switching from SCK Pin Function to Port Pin Function
(Example of Preventing Low-Level Output)**

Section 14 Smart Card Interface

14.1 Overview

As an extension of its serial communication interface functions, SCI0 supports a smart card (IC card) interface conforming to the ISO/IEC7816-3 (Identification Card) standard. Switchover between normal serial communication and the smart card interface is controlled by a register setting.

14.1.1 Features

Features of the smart-card interface supported by the H8/3048B Group are listed below.

- Asynchronous communication
 - Data length: 8 bits
 - Parity bits generated and checked
 - Error signal output in receive mode (parity error)
 - Error signal detect and automatic data retransmit in transmit mode
 - Supports both direct convention and inverse convention
- Built-in baud rate generator with selectable bit rates
- Three types of interrupts

Transmit-data-empty, receive-data-full, and receive-error interrupts are requested independently. The transmit-data-empty and receive-data-full interrupts can activate the DMA controller (DMAC) to transfer data.

14.1.2 Block Diagram

Figure 14.1 shows a block diagram of the smart card interface.

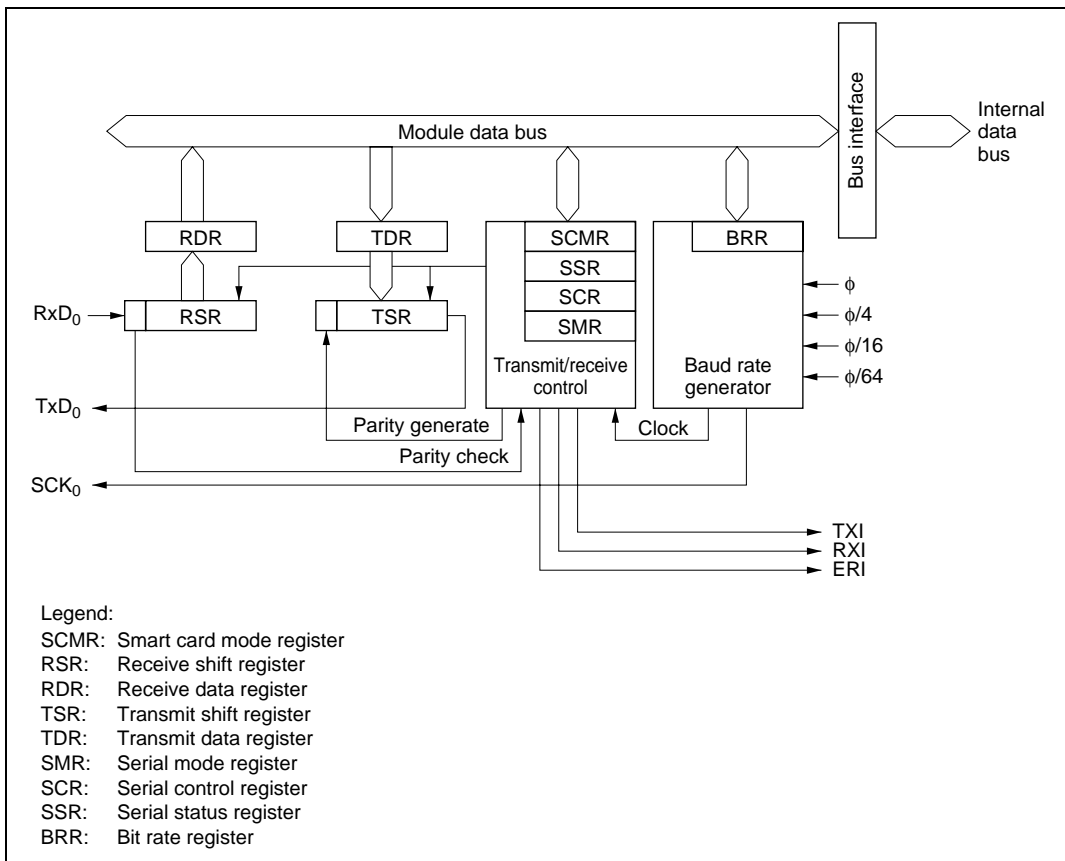

Figure 14.1 Smart Card Interface Block Diagram

14.1.3 Input/Output Pins

Table 14.1 lists the smart card interface pins.

Table 14.1 Smart Card Interface Pins

Name	Abbreviation	I/O	Function
Serial clock pin	SCK ₀	Output	Clock output
Receive data pin	RxD ₀	Input	Receive data input
Transmit data pin	TxD ₀	Output	Transmit data output

14.1.4 Register Configuration

The smart card interface has the internal registers listed in table 14.2. BRR, TDR, and RDR have their normal serial communication interface functions, as described in section 13, Serial Communication Interface.

Table 14.2 Registers

Address* ¹	Name	Abbreviation	R/W	Initial Value
H'FFB0	Serial mode register	SMR	R/W	H'00
H'FFB1	Bit rate register	BRR	R/W	H'FF
H'FFB2	Serial control register	SCR	R/W	H'00
H'FFB3	Transmit data register	TDR	R/W	H'FF
H'FFB4	Serial status register	SSR	R/(W) ^{*2}	F'84
H'FFB5	Receive data register	RDR	R	H'00
H'FFB6	Smart card mode register	SCMR	R/W	H'F2

- Notes: 1. Lower 16 bits of the address.
2. Only 0 can be written, to clear flags.

14.2 Register Descriptions

This section describes the new or modified registers and bit functions in the smart card interface.

14.2.1 Smart Card Mode Register (SCMR)

SCMR is an 8-bit readable/writable register that selects smart card interface functions.

Bit	7	6	5	4	3	2	1	0
	—	—	—	—	SDIR	SINV	—	SMIF
Initial value	1	1	1	1	0	0	1	0
Read/Write	—	—	—	—	R/W	R/W	—	R/W

Reserved bits (Bits 7, 6, 5, 4)
Reserved bits (Bits 3, 2)
Smart card interface mode select
 Enables or disables the smart card interface function (Bit 1)
Smart card data invert
 Inverts data logic levels (Bit 2)
Smart card data transfer direction
 Selects the serial/parallel conversion format (Bit 3)

SCMR is initialized to H'F2 by a reset and in standby mode.

Bits 7 to 4—Reserved: Read-only bits, always read as 1.

Bit 3—Smart Card Data Transfer Direction (SDIR): Selects the serial/parallel conversion format.

Bit 3: SDIR	Description
0	TDR contents are transmitted LSB-first Received data is stored LSB-first in RDR (Initial value)
1	TDR contents are transmitted MSB-first Received data is stored MSB-first in RDR

Bit 2—Smart Card Data Inverter (SINV): Inverts data logic levels. This function is used in combination with bit 3 to communicate with inverse-convention cards. SINV does not affect the logic level of the parity bit. For parity settings, see section 14.3.4, Register Settings.

Bit 2: SINV	Description
0	Unmodified TDR contents are transmitted (Initial value) Received data is stored unmodified in RDR
1	Inverted TDR contents are transmitted Received data is inverted before storage in RDR

Bit 1—Reserved: Read-only bit, always read as 1.

Bit 0—Smart Card Interface Mode Select (SMIF): Enables the smart card interface function.

Bit 0: SMIF	Description
0	Smart card interface function is disabled (Initial value)
1	Smart card interface function is enabled

14.2.2 Serial Status Register (SSR)

The function of SSR bit 4 is modified in the smart card interface. This change also causes a modification to the setting conditions for bit 2 (TEND).

Bit	7	6	5	4	3	2	1	0
	TDRE	RDRF	ORER	ERS	PER	TEND	MPB	MPBT
Initial value	1	0	0	0	0	1	0	0
Read/Write	R/(W)*	R/(W)*	R/(W)*	R/(W)*	R/(W)*	R	R	R/W

Transmit end
Status flag indicating
end of transmission

Error signal status (ERS)
Status flag indicating that an
error signal has been received

Note: * Only 0 can be written, to clear the flag.

Bits 7 to 5: These bits operate as in normal serial communication. For details see section 13, Serial Communication Interface.

Bit 4—Error Signal Status (ERS): In smart card interface mode, this flag indicates the status of the error signal sent from the receiving device to the transmitting device. The smart card interface does not detect framing errors.

Bit 4: ERS	Description
0	Indicates normal data transmission, with no error signal returned (Initial value) [Clearing conditions] The chip is reset or enters standby mode. Software reads ERS while it is set to 1, then writes 0.
1	Indicates that the receiving device sent an error signal reporting a parity error [Setting condition] A low error signal was sampled.

Note: Clearing the TE bit to 0 in SCR does not affect the ERS flag, which retains its previous value.

Bits 3 to 0: These bits operate as in normal serial communication. For details see section 13, Serial Communication Interface. The setting conditions for transmit end (TEND, bit 2), however, are modified as follows.

Bit 2: TEND	Description
0	Transmission is in progress [Clearing conditions] Software reads TDRE while it is set to 1, then writes 0 in the TDRE flag. The DMAC writes data in TDR.
1	End of transmission (Initial value) [Setting conditions] The chip is reset or enters standby mode. The TE bit and FER/ERS bit are both cleared to 0 in SCR. TDRE is 1 and FER/ERS is 0 at a time 2.5 etu after the last bit of a 1-byte serial character is transmitted (normal transmission)

Note: An etu (elementary time unit) is the time needed to transmit one bit.

14.2.3 Serial Mode Register (SMR)

Bit 7 of SMR has a different function in smart card interface mode. The related serial control register (SCR) changes from bit 1 to bit 0. However, this function does not exist in the flash memory version.

Bit	7	6	5	4	3	2	1	0
	GM	CHR	PE	O/ \bar{E}	STOP	MP	CKS1	CKS0
Initial value	0	0	0	0	0	0	0	0
Read/Write	R/W	R/W	R/W	R/W	R/W	R/W	R/W	R/W

Bit 7—GSM Mode (GM): Set at 0 when using the regular smart card interface. In GSM mode, set to 1. When transmission is complete, initially the TEND flag set timing appears followed by clock output restriction mode. Clock output restriction mode comprises serial control register bit 1 and bit 0.

Bit 7: GM Description

0	Using the regular smart card interface mode <ul style="list-style-type: none"> The TEND flag is set 12.5 etu after the beginning of the start bit (Initial value) Clock output on/off control only
1	Using the GSM mode smart card interface mode <ul style="list-style-type: none"> The TEND flag is set 11.0 etu after the beginning of the start bit Clock output on/off and fixed-high/fixed-low control (set by SCR)

Bits 6 to 0—Operate in the same way as for the normal SCI.

For details, see section 13.2.5, Serial Mode Register (SMR).

14.2.4 Serial Control Register (SCR)

Bits 1 and 0 have different functions in smart card interface mode. However, this function does not exist in the flash memory version.

Bit	7	6	5	4	3	2	1	0
	TIE	RIE	TE	RE	MPIE	TEIE	CKE1	CKE0
Initial value	0	0	0	0	0	0	0	0
Read/Write	R/W	R/W	R/W	R/W	R/W	R/W	R/W	R/W

Bits 7 to 2—Operate in the same way as for the normal SCI.

For details, see section 13.2.6, Serial Control Register (SCR).

Bits 1 and 0—Clock Enable (CKE1, CKE0): Setting enable or disable for the SCI clock selection and clock output from the SCK pin. In smart card interface mode, it is possible to switch between enabling and disabling of the normal clock output, and specify a fixed high level or fixed low level for the clock output.

SMR	SCR		Description
Bit 7: GM	Bit 1: CKE1	Bit 0: CKE0	
0	0	0	The internal clock/SCK ₀ pin functions as an I/O port (Initial value)
0	0	1	The internal clock/SCK ₀ pin functions as the clock output
1	0	0	The internal clock/SCK ₀ pin is fixed at low-level output
1	0	1	The internal clock/SCK ₀ pin functions as the clock output
1	1	0	The internal clock/SCK ₀ pin is fixed at high-level output
1	1	1	The internal clock/SCK ₀ pin functions as the clock output

14.3 Operation

14.3.1 Overview

The main features of the smart-card interface are as follows.

- One frame consists of eight data bits and a parity bit.
- In transmitting, a guard time of at least two elementary time units (2 etu) is provided between the end of the parity bit and the start of the next frame. (An elementary time unit is the time required to transmit one bit.)
- In receiving, if a parity error is detected, a low error signal is output for 1 etu, beginning 10.5 etu after the start bit.
- In transmitting, if an error signal is received, after at least 2 etu, the same data is automatically transmitted again.
- Only asynchronous communication is supported. There is no synchronous communication function.

14.3.2 Pin Connections

Figure 14.2 shows a pin connection diagram for the smart card interface.

In communication with a smart card, data is transmitted and received over the same signal line. The TxD_0 and RxD_0 pins should both be connected to this line. The data transmission line should be pulled up to V_{CC} through a resistor.

If the smart card uses the clock generated by the smart card interface, connect the SCK_0 output pin to the card's CLK input. If the card uses its own internal clock, this connection is unnecessary.

The reset signal should be output from one of the H8/3048B Group's generic ports.

In addition to these pin connections, power and ground connections will normally also be necessary.

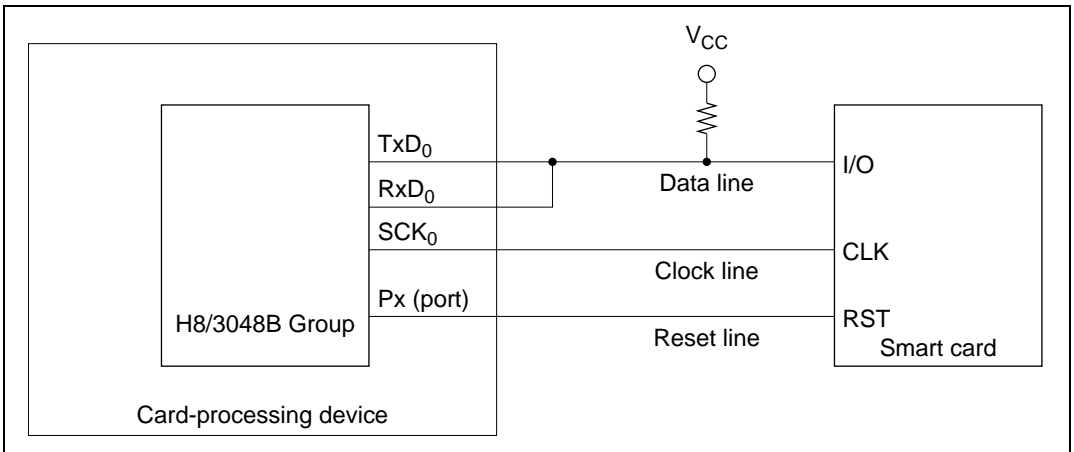

Figure 14.2 Smart Card Interface Connection Diagram

Note: A loop-back test can be performed by setting both RE and TE to 1 without connecting a smart card.

14.3.3 Data Format

Figure 14.3 shows the data format of the smart card interface. In receive mode, parity is checked once per frame. If a parity error is detected, an error signal is returned to the transmitting device to request retransmission. In transmit mode, the error signal is sampled and the same data is retransmitted if the error signal is low.

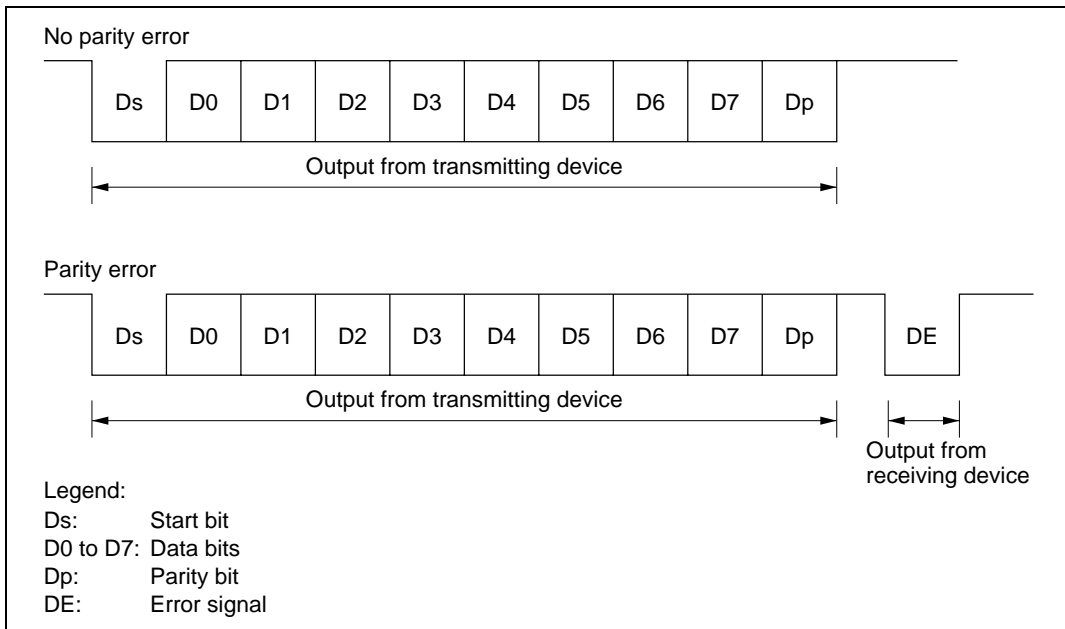

Figure 14.3 Smart Card Interface Data Format

The operating sequence is as follows.

1. When not in use, the data line is in the high-impedance state, and is pulled up to the high level through a resistor.
2. To start transmitting a frame of data, the transmitting device transmits a low start bit (Ds), followed by eight data bits (D0 to D7) and a parity bit (Dp).
3. Next, in the smart card interface, the transmitting device returns the data line to the high-impedance state. The data line is pulled up to the high level through a resistor.
4. The receiving device performs a parity check. If there is no parity error, the receiving device waits to receive the next data. If a parity error is present, the receiving device outputs a low error signal (DE) to request retransmission of the data. After outputting the error signal for a designated interval, the receiving device returns the signal line to the high-impedance state. The signal line is pulled back up to the high level through the pull-up resistor.
5. If the transmitting device does not receive an error signal, it proceeds to transmit the next data. If it receives an error signal, it returns to step 2 and transmits the same data again.

14.3.4 Register Settings

Table 14.3 shows a bit map of the registers used in the smart card interface. Bits indicated as 0 or 1 should always be set to the indicated value. The settings of the other bits will be described in this section.

Table 14.3 Register Settings in Smart Card Interface

Register	Address ^{*1}	Bit 7	Bit 6	Bit 5	Bit 4	Bit 3	Bit 2	Bit 1	Bit 0
SMR	H'FFB0	GM	0	1	O/ \bar{E}	1	0	CKS1	CKS0
BRR	H'FFB1	BRR7	BRR6	BRR5	BRR4	BRR3	BRR2	BRR1	BRR0
SCR	H'FFB2	TIE	RIE	TE	RE	0	0	CKE1 ^{*2}	CKE0
TDR	H'FFB3	TDR7	TDR6	TDR5	TDR4	TDR3	TDR2	TDR1	TDR0
SSR	H'FFB4	TDRE	RDRF	ORER	ERS	PER	TEND	0	0
RDR	H'FFB5	RDR7	RDR6	RDR5	RDR4	RDR3	RDR2	RDR1	RDR0
SCMR	H'FFB6	—	—	—	—	SDIR	SINV	—	SMIF

Legend: —: Unused bit.

Notes: 1. Lower 16 bits of the address.

2. When the GM of the SMR is set at 0, be sure the CKE1 bit is 0.

Serial Mode Register (SMR) Settings: In regular smart card interface mode, set the GM bit at 0. In regular smart card mode, clear the GM bit to 0. In GSM mode, set the GM bit to 1. Clear the O/ \bar{E} bit to 0 if the smart card uses the direct convention. Set the O/ \bar{E} bit to 1 if the smart card uses the inverse convention. Bits CKS1 and CKS0 select the clock source of the built-in baud rate generator. See section 14.3.5, Clock.

Bit Rate Register (BRR) Settings: This register sets the bit rate. Equations for calculating the setting are given in section 14.3.5, Clock.

Serial Control Register (SCR): The TIE, RIE, TE, and RE bits have their normal serial communication functions. For details, see section 13, Serial Communication Interface. The CKE1 and CKE0 bits select clock output. When the GM bit of the SMR is cleared to 0, to disable clock output, clear this bit to 00. To enable clock output, set this bit to 01. When the GM bit of the SMR is set to 1, clock output is enabled. Clock output is fixed at high or low.

Smart Card Mode Register (SCMR): If the smart card follows the direct convention, clear the SDIR and SINV bits to 0. If the smart card follows the indirect convention, set the SDIR and SINV bits to 1. To use the smart card interface, set the SMIF bit to 1.

The register settings and examples of starting character waveforms are shown below for two smart cards, one following the direct convention and one the inverse convention.

- Direct convention ($SDIR = SINV = O/\bar{E} = 0$)

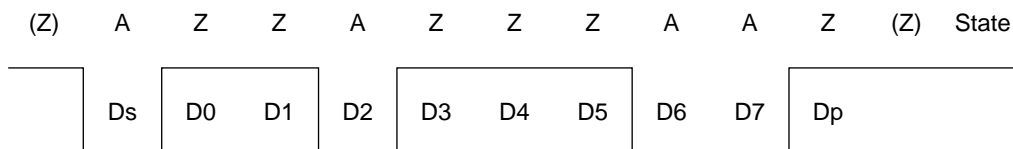

In the direct convention, state Z corresponds to logic level 1, and state A to logic level 0. Characters are transmitted and received LSB-first. In the example above the first character data is H'3B. The parity bit is 1, following the even parity rule designated for smart cards.

- Inverse convention ($SDIR = SINV = O/\bar{E} = 1$)

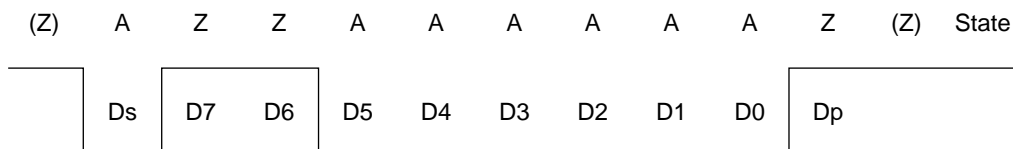

In the inverse convention, state A corresponds to the logic level 1, and state Z to the logic level 0. Characters are transmitted and received MSB-first. In the example above the first character data is H'3F. Following the even parity rule designated for smart cards, the parity bit logic level is 0, corresponding to state Z.

In the H8/3048B Group, the SINV bit inverts only the data bits D7 to D0. The parity bit is not inverted, so the O/\bar{E} bit in SMR must be set to odd parity mode. This applies in both transmitting and receiving.

14.3.5 Clock

As its serial communication clock, the smart card interface can use only the internal clock generated by the on-chip baud rate generator. The bit rate can be selected by setting the bit rate register (BRR) and bits CKS1 and CKS0 in the serial mode register (SMR). The bit rate can be calculated from the equation given below. Table 14.5 lists some examples of bit rate settings.

If bit CKE0 is set to 1, a clock signal with a frequency equal to 372 times the bit rate is output from the SCK₀ pin.

$$B = \frac{\phi}{1488 \times 2^{2n-1} \times (N + 1)} \times 10^6$$

where, N: BRR setting ($0 \leq N \leq 255$)

B: Bit rate (bits/s)

ϕ : System clock frequency (MHz)*

n: See table 14.4

Table 14.4 n-Values of CKS1 and CKS0 Settings

n	CKS1	CKS0
0	0	0
1	0	1
2	1	0
3	1	1

Note: * If the gear function is used to divide the system clock frequency, use the divided frequency to calculate the bit rate. The equation above applies directly to 1/1 frequency division.

Table 14.5 Bit Rates (bits/s) for Different BRR Settings (when n = 0)

N	ϕ (MHz)								
	7.1424	10.00	10.7136	13.00	14.2848	16.00	18.00	20.00	25.00
0	9600.0	13440.9	14400.0	17473.1	19200.0	21505.4	24193.5	26881.7	33602.2
1	4800.0	6720.4	7200.0	8736.6	9600.0	10752.7	12096.8	13440.9	16801.1
2	3200.0	4480.3	4800.0	5824.4	6400.0	7168.5	8064.5	8960.6	11200.7

Note: Bit rates are rounded off to one decimal place.

The following equation calculates the bit rate register (BRR) setting from the system clock frequency and bit rate. N is an integer from 0 to 255, specifying the value with the smaller error.

$$N = \frac{\phi}{1488 \times 2^{2n-1} \times B} \times 10^6 - 1$$

Table 14.6 BRR Settings for Typical Bit Rate (bits/s) (when n = 0)

Bit/s	ϕ (MHz)																	
	7.1424		10.00		10.7136		13.00		14.2848		16.00		18.00		20.00		25.00	
	N	Error	N	Error	N	Error	N	Error	N	Error	N	Error	N	Error	N	Error	N	Error
9600	0	0.00	1	30.00	1	25.00	1	8.99	1	0.00	1	12.01	2	15.99	2	6.66	3	12.49

Table 14.7 Maximum Bit Rates for Various Frequencies (Smart Card Interface)

ϕ (MHz)	Maximum Bit Rate (bits/s)	N	n
7.1424	9600	0	0
10.00	13441	0	0
10.7136	14400	0	0
13.00	17473	0	0
14.2848	19200	0	0
16.00	21505	0	0
18.00	24194	0	0
20.00	26882	0	0
25.00	33602	0	0

The bit rate error is calculated from the following equation.

$$\text{Error (\%)} = \left\{ \frac{\phi}{1488 \times 2^{2n-1} \times B \times (N + 1)} \times 10^6 - 1 \right\} \times 100$$

14.3.6 Transmitting and Receiving Data

Initialization

Before transmitting or receiving data, initialize the smart card interface by the procedure below. Initialization is also necessary when switching from transmit mode to receive mode or from receive mode to transmit mode.

1. Clear the TE and RE bits to 0 in the serial control register (SCR).
2. Clear the ERS, PER, and ORER error flags to 0 in the serial status register (SSR).
3. Set the parity mode bit (O/\bar{E}) and baud rate generator clock source select bits (CKS1 and CKS0) as required in the serial mode register (SMR). At the same time, clear the C/\bar{A} , CHR, and MP bits to 0, and set the STOP and PE bits to 1.
4. Set the SMIF, SDIR, and SINV bits as required in the smart card mode register (SCMR).
When the SMIF bit is set to 1, the Tx D_0 and Rx D_0 pins switch from their I/O port functions to their serial communication interface functions, and are placed in the high-impedance state.
5. Set a value corresponding to the desired bit rate in the bit rate register (BRR).
6. Set clock enable bit 0 (CKE0) as required in the serial control register (SCR). Write 0 in the TIE, RIE, TE, RE, MPIE, TEIE, and CKE1 bits. If bit CKE0 is set to 1, a serial clock will be output from the SCK $_0$ pin.
7. Wait for at least the interval required to transmit or receive one bit, then set the TIE, RIE, TE, and RE bits as necessary in SCR. Do not set TE and RE both to 1, except when performing a loop-back test.

Transmitting Serial Data

The transmitting procedure in smart card mode is different from the normal SCI procedure, because of the need to sample the error signal and retransmit. Figure 14.4 shows a flowchart for transmitting, and figure 14.5 shows the relation between a transmit operation and the internal registers.

1. Initialize the smart card interface by the procedure given above in Initialization.
2. Check that the ERS error flag is cleared to 0 in SSR.
3. Check that the TEND flag is set to 1 in SSR. Repeat steps 2 and 3 until this check passes.
4. Write transmit data in TDR and clear the TDRE flag to 0. The data will be transmitted and the TEND flag will be cleared to 0.
5. To continue transmitting data, return to step 2.
6. To terminate transmission, clear the TE bit to 0.

This procedure may include interrupt handling and DMA transfer.

If the TIE bit is set to 1 to enable interrupt requests, when transmission is completed and the TEND flag is set to 1, a transmit-data-empty interrupt (TXI) is requested. If the RIE bit is set to 1 to enable interrupt requests, when a transmit error occurs and the ERS flag is set to 1, a transmit/receive-error interrupt (ERI) is requested.

The timing of TEND flag setting depends on the GM bit in SMR. The timing is shown in figure 14.6.

If the TXI interrupt activates the DMAC, the number of bytes designated in the DMAC can be transmitted automatically, including automatic retransmit.

For details, see Interrupt Operations and Data Transfer by DMAC in this section.

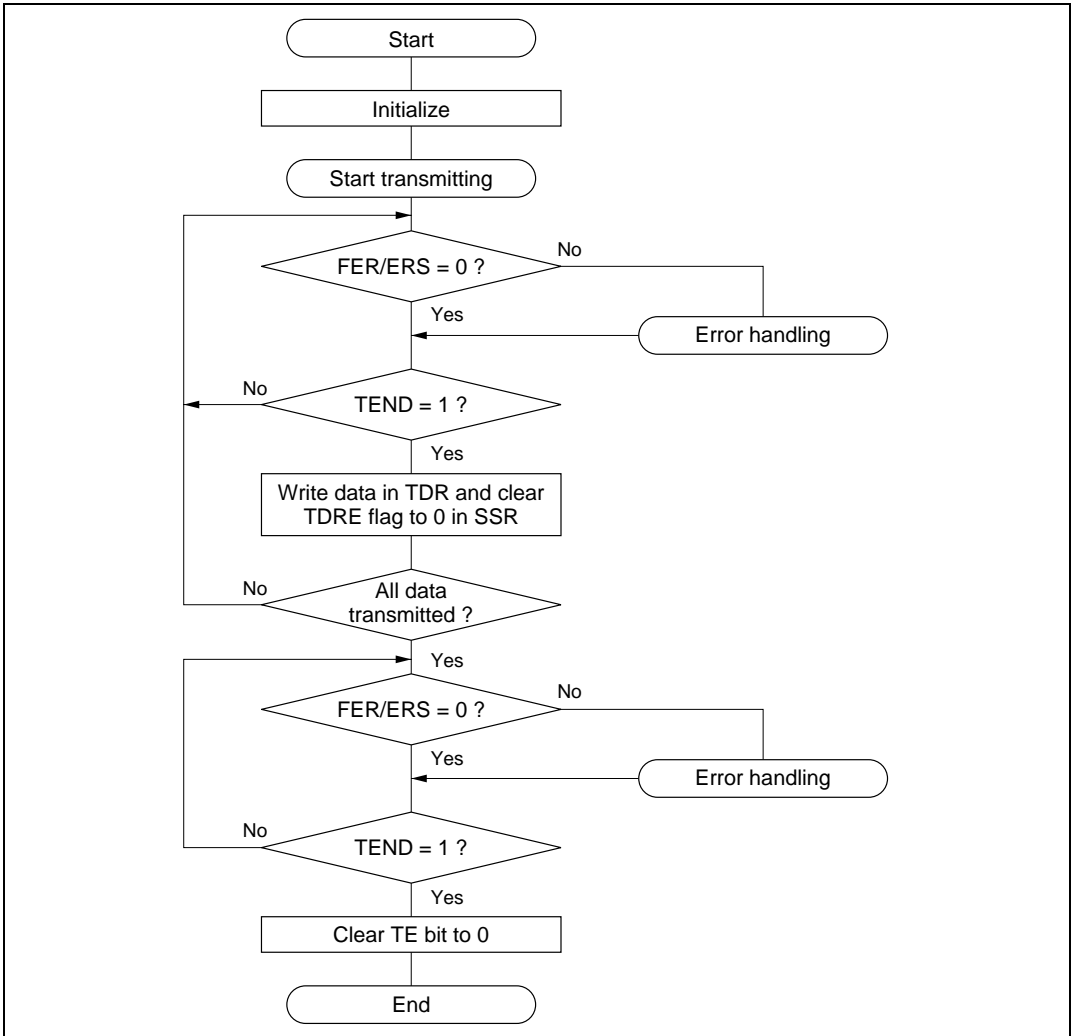

Figure 14.4 Transmit Flowchart (Example)

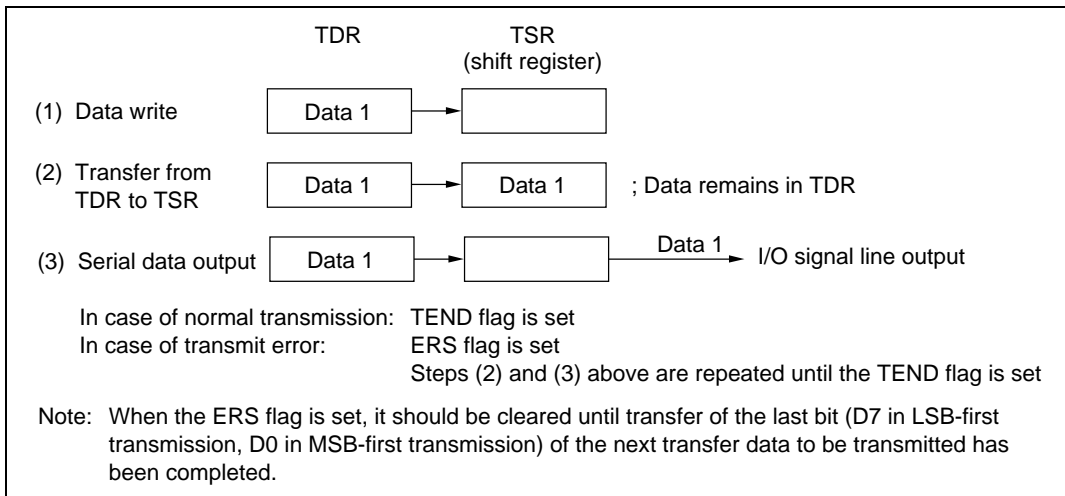

Figure 14.5 Relation Between Transmit Operation and Internal Registers

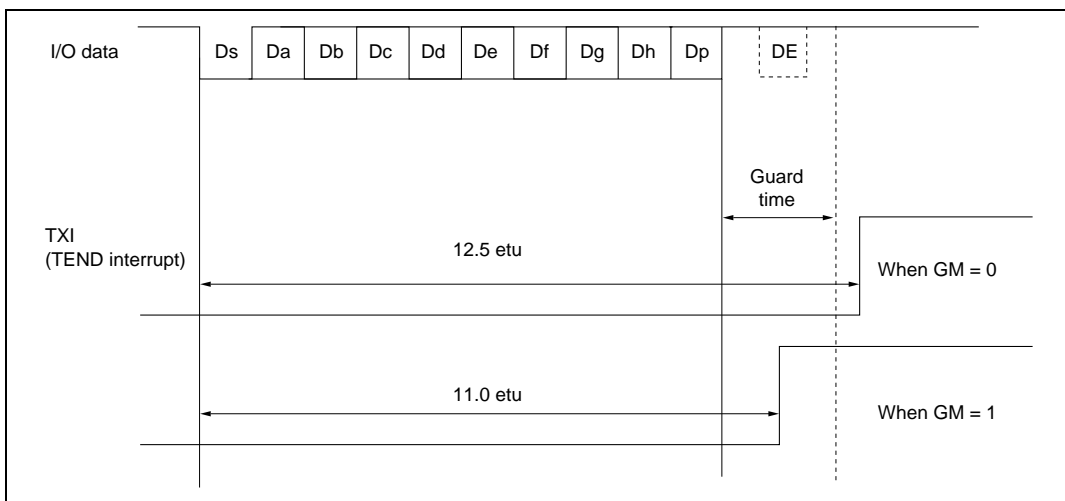

Figure 14.6 TEND Flag Occurrence Timing

Receiving Serial Data

The receiving procedure in smart card mode is the same as the normal SCI procedure. Figure 14.7 shows a flowchart for receiving.

1. Initialize the smart card interface by the procedure given in Initialization at the beginning of this section.
2. Check that the ORER and PER error flags are cleared to 0 in SSR. If either flag is set, carry out the necessary error handling, then clear both the ORER and PER flags to 0.
3. Check that the RDRF flag is set to 1. Repeat steps 2 and 3 until this check passes.
4. Read receive data from RDR.
5. To continue receiving data, clear the RDRF flag to 0 and return to step 2.
6. To terminate receiving, clear the RE bit to 0.

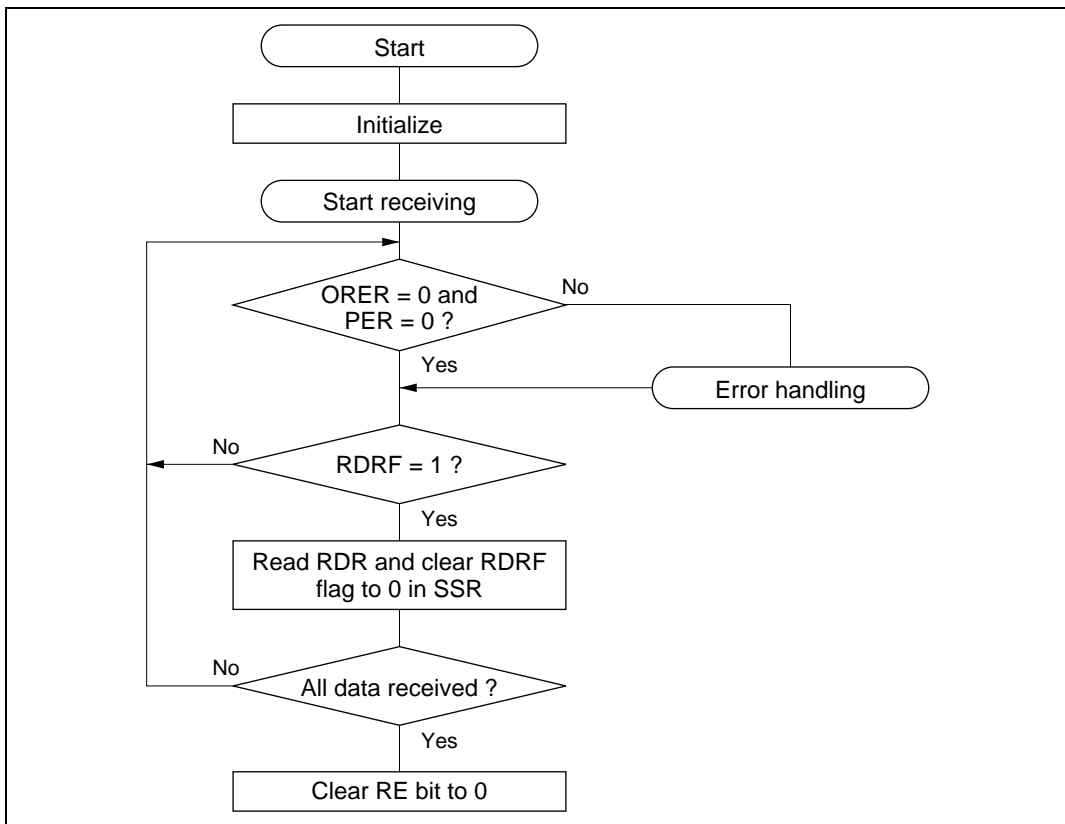

Figure 14.7 Receive Flowchart (Example)

This procedure may include interrupt handling and DMA transfer.

If the RIE bit is set to 1 to enable interrupt requests, when receiving is completed and the RDRF flag is set to 1, a receive-data-full interrupt (RXI) is requested. If a receive error occurs, either the ORER or PER flag is set to 1 and a transmit/receive-error interrupt (ERI) is requested.

If the RXI interrupt activates the DMAC, the number of bytes designated in the DMAC will be transferred, skipping receive data in which an error occurred.

For details, see Interrupt Operations and Data Transfer by DMAC below.

When a parity error occurs and PER is set to 1, the receive data is transferred to RDR, so the erroneous data can be read.

Switching Modes

To switch from receive mode to transmit mode, check that receiving operations have completed, then initialize the smart card interface, clearing RE to 0 and setting TE to 1. Completion of receive operations is indicated by the RDRF, PER, or ORER flag.

To switch from transmit mode to receive mode, check that transmitting operations have completed, then initialize the smart card interface, clearing TE to 0 and setting RE to 1. Completion of transmit operations can be verified from the TEND flag.

Fixing Clock Output

When the GM bit of the SMR is set to 1, clock output is fixed by CKE1 and CKE0 of SCR. In this case, the clock pulse can be set at minimum value.

Figure 14.8 shows clock output fixed timing: CKE0 is restricted with GM = 1 and CKE1 = 1.

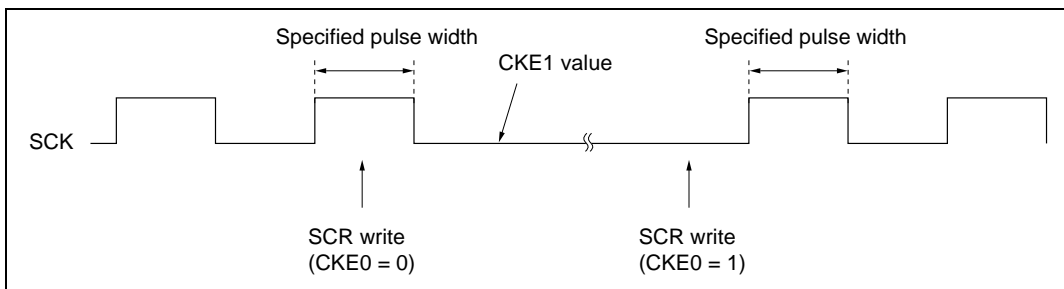

Figure 14.8 Clock Output Fixed Timing

Interrupt Operations

The smart card interface has three interrupt sources: transmit-data-empty (TXI), transmit/receive-error (ERI), and receive-data-full (RXI). The transmit-end interrupt request (TEI) is not available in smart card mode.

A TXI interrupt is requested when the TEND flag is set to 1 in SSR. An RXI interrupt is requested when the RDRF flag is set to 1 in SSR. An ERI interrupt is requested when the ORER, PER, or ERS flag is set to 1 in SSR. These relationships are shown in table 14.8.

Table 14.8 Smart Card Mode Operating States and Interrupt Sources

Operating State		Flag	Mask Bit	Interrupt Source	DMAC Activation
Transmit mode	Normal operation	TEND	TIE	TXI	Available
	Error	ERS	RIE	ERI	Not available
Receive mode	Normal operation	RDRF	RIE	RXI	Available
	Error	PER, ORER	RIE	ERI	Not available

Data Transfer by DMAC

The DMAC can be used to transmit and receive in smart card mode, as in normal SCI operations. In transmit mode, when the TEND flag is set to 1 in SSR, the TDRE flag is set simultaneously, generating a TXI interrupt. If TXI is designated in advance as a DMAC activation source, the DMAC will be activated by the TXI request and will transfer the next transmit data. This data transfer by the DMAC automatically clears the TDRE and TEND flags to 0. When an error occurs, the SCI automatically retransmits the same data, keeping TEND cleared to 0 so that the DMAC is not activated. The SCI and DMAC will therefore automatically transmit the designated number of bytes, including retransmission when an error occurs. When an error occurs the ERS flag is not cleared automatically, so the RIE bit should be set to 1 to enable the error to generate an ERI request, and the ERI interrupt handler should clear ERS.

When using the DMAC to transmit or receive, first set up and enable the DMAC, then make SCI settings. DMAC settings are described in section 8, DMA Controller.

In receive operations, when the RDRF flag is set to 1 in SSR, an RXI interrupt is requested. If RXI is designated in advance as a DMAC activation source, the DMAC will be activated by the RXI request and will transfer the received data. This data transfer by the DMAC automatically clears the RDRF flag to 0. When an error occurs, the RDRF flag is not set and an error flag is set instead. The DMAC is not activated. The ERI interrupt request is directed to the CPU. The ERI interrupt handler should clear the error flags.

Examples of Operation in GSM Mode

When switching between smart card interface mode and software standby mode, use the following procedures to maintain the clock duty cycle.

- Switching from smart card interface mode to software standby mode
 1. Set the P9₄ data register (DR) and data direction register (DDR) to the values for the fixed output state in software standby mode.
 2. Write 0 to the TE and RE bits in the serial control register (SCR) to stop transmit/receive operations. At the same time, set the CKE1 bit to the value for the fixed output state in software standby mode.
 3. Write 0 to the CKE0 bit in SCR to stop the clock.
 4. Wait for one serial clock cycle. During this period, the duty cycle is preserved and clock output is fixed at the specified level.
 5. Write H'00 to the serial mode register (SMR) and smart card mode register (SCMR).
 6. Make the transition to the software standby state.

- Returning from software standby mode to smart card interface mode
 1. Clear the software standby state.
 2. Set the CKE1 bit in SCR to the value for the fixed output state at the start of software standby (the current P9₄ pin state).
 3. Set smart card interface mode and output the clock. Clock signal generation is started with the normal duty cycle.

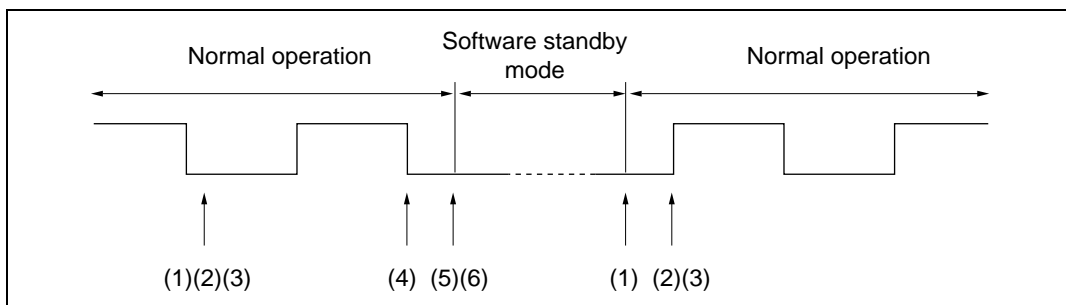

Figure 14.9 Procedure for Stopping and Restarting the Clock

Use the following procedure to secure the clock duty cycle after powering on.

1. The initial state is port input and high impedance. Use pull-up or pull-down resistors to fix the potential.
2. Fix at the output specified by the CKE1 bit in SCR.
3. Set SMR and SCMR, and switch to smart card interface mode operation.
4. Set the CKE0 bit in SCR to 1 to start clock output.

14.4 Usage Notes

When using the SCI as a smart card interface, note the following points.

Receive Data Sampling Timing in Smart Card Mode and Receive Margin

In smart card mode the SCI operates on a base clock with 372 times the bit rate frequency. In receiving, the SCI synchronizes internally with the fall of the start bit, which it samples on the base clock. Receive data is latched at the rising edge of the 186th base clock pulse. See figure 14.10.

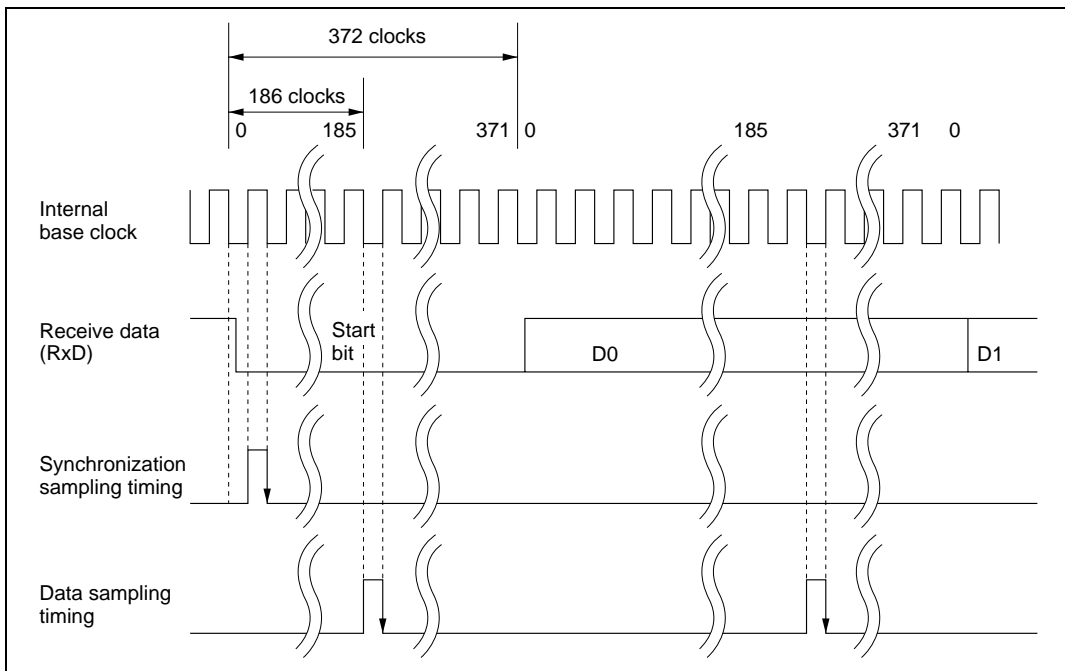

Figure 14.10 Receive Data Sampling Timing in Smart Card Mode

The receive margin can therefore be expressed as follows.

Receive margin in smart card mode:

$$M = \left| \left\{ 0.5 - \frac{1}{2N} \right\} - (L - 0.5) F - \frac{|D - 0.5|}{N} (1 + F) \right| \times 100\%$$

M: Receive margin (%)

N: Ratio of clock frequency to bit rate (N = 372)

D: Clock duty cycle (D = 0 to 1.0)

L: Frame length (L = 10)

F: Absolute deviation of clock frequency

From this equation, if F = 0 and D = 0.5 the receive margin is as follows.

$$D = 0.5, F = 0$$

$$M = \{0.5 - 1/(2 \times 372)\} \times 100\%$$

$$= 49.866\%$$

Retransmission

Retransmission is described below for the separate cases of transmit mode and receive mode.

- Retransmission when SCI is in Receive Mode (see figure 14.11)
 - (1) The SCI checks the received parity bit. If it detects an error, it automatically sets the PER flag to 1. If the RIE bit in SCR is set to the enable state, an ERI interrupt is requested. The PER flag should be cleared to 0 in SSR before the next parity bit sampling timing.
 - (2) The RDRF bit in SSR is not set to 1 for the error frame.
 - (3) If an error is not detected when the parity bit is checked, the PER flag is not set in SSR.
 - (4) If an error is not detected when the parity bit is checked, receiving operations are assumed to have ended normally, and the RDRF bit is automatically set to 1 in SSR. If the RIE bit in SCR is set to the enable state, an RXI interrupt is requested. If RXI is enabled as a DMA transfer activation source, the RDR contents can be read automatically. When the DMAC reads the RDR data, it automatically clears RDRF to 0.
 - (5) When a normal frame is received, at the error signal transmit timing, the data pin is held in the high-impedance state.

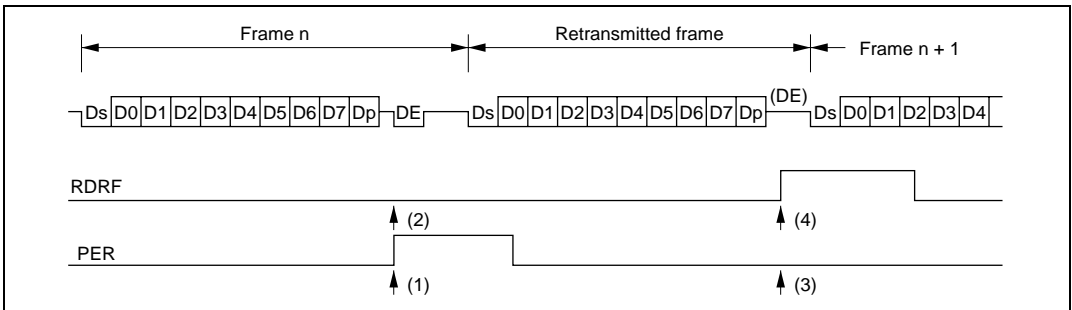

Figure 14.11 Retransmission in SCI Receive Mode

- Retransmission when SCI is in Transmit Mode (see figure 14.12)
 - (6) After transmitting one frame, if the receiving device returns an error signal, the SCI sets the ERS flag to 1 in SSR. If the RIE bit in SCR is set to the enable state, an ERI interrupt is requested. The ERS flag should be cleared to 0 in SSR before the next parity bit sampling timing.
 - (7) The TEND bit in SSR is not set for the frame in which the error signal was received, indicating an error.
 - (8) If no error signal is returned from the receiving device, the ERS flag is not set in SSR.
 - (9) If no error signal is returned from the receiving device, transmission of the frame, including retransmission, is assumed to be complete, and the TEND bit is set to 1 in SSR. If the TIE bit in SCR is set to the enable state, a TXI interrupt is requested. If TXI is enabled as a DMA transfer activation source, the next data can be written in TDR automatically. When the DMAC writes data in TDR, it automatically clears the TDRE bit to 0.

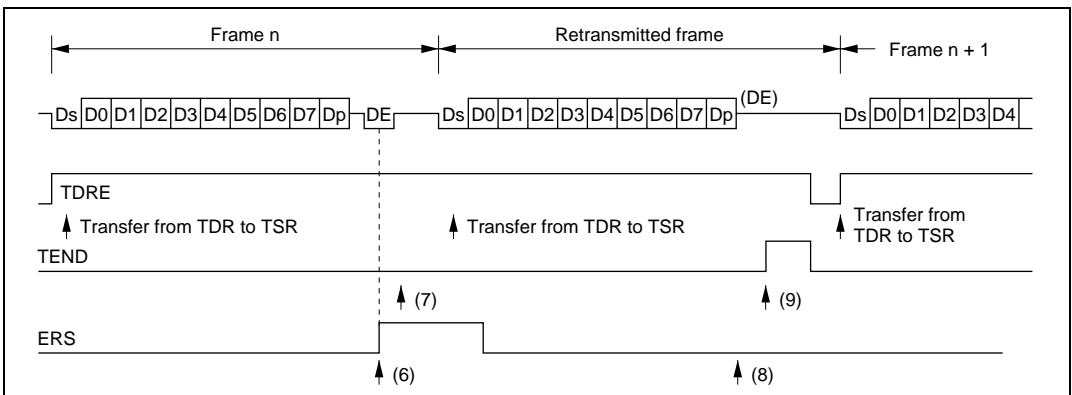

Figure 14.12 Retransmission in SCI Transmit Mode

Section 15 A/D Converter

15.1 Overview

The H8/3048B Group includes a 10-bit successive-approximations A/D converter with a selection of up to eight analog input channels.

When the A/D converter is not used, it can be halted independently to conserve power. For details see section 20.6, Module Standby Function.

15.1.1 Features

A/D converter features are listed below.

- 10-bit resolution
- Eight input channels
- Selectable analog conversion voltage range
The analog voltage conversion range can be programmed by input of an analog reference voltage at the V_{REF} pin.
- High-speed conversion
Conversion time: Minimum 5.36 μ s per channel (with 25-MHz system clock)
- Two conversion modes
Single mode: A/D conversion of one channel
Scan mode: continuous conversion on one to four channels
- Four 16-bit data registers
A/D conversion results are transferred for storage into data registers corresponding to the channels.
- Sample-and-hold function
- A/D conversion can be externally triggered
- A/D interrupt requested at end of conversion
At the end of A/D conversion, an A/D end interrupt (ADI) can be requested.

15.1.2 Block Diagram

Figure 15.1 shows a block diagram of the A/D converter.

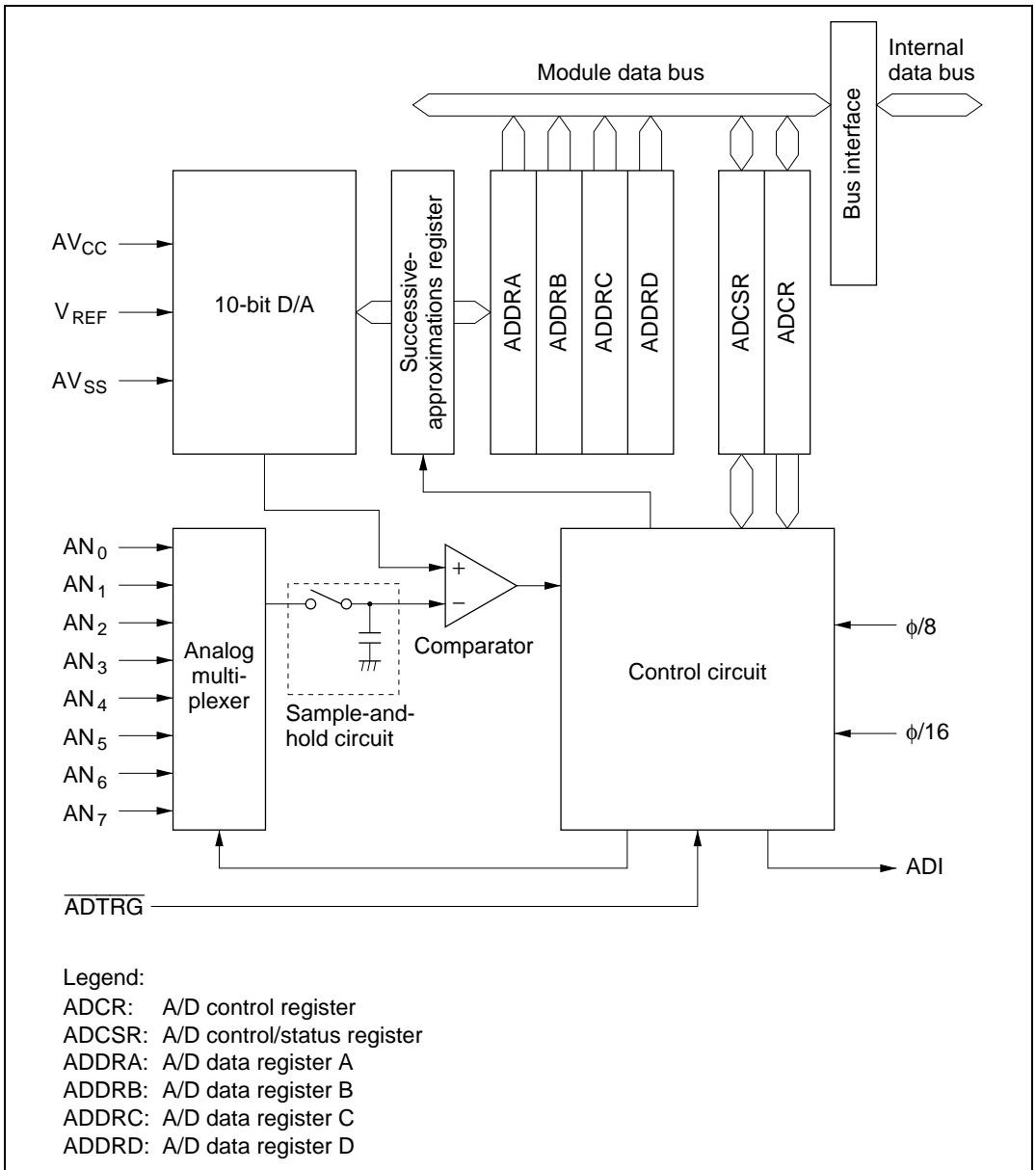

Figure 15.1 A/D Converter Block Diagram

15.1.3 Input Pins

Table 15.1 summarizes the A/D converter's input pins. The eight analog input pins are divided into two groups: group 0 (AN_0 to AN_3), and group 1 (AN_4 to AN_7). AV_{CC} and AV_{SS} are the power supply for the analog circuits in the A/D converter. V_{REF} is the A/D conversion reference voltage.

Table 15.1 A/D Converter Pins

Pin Name	Abbreviation	I/O	Function
Analog power supply pin	AV_{CC}	Input	Analog power supply
Analog ground pin	AV_{SS}	Input	Analog ground and reference voltage
Reference voltage pin	V_{REF}	Input	Analog reference voltage
Analog input pin 0	AN_0	Input	Group 0 analog inputs
Analog input pin 1	AN_1	Input	
Analog input pin 2	AN_2	Input	
Analog input pin 3	AN_3	Input	
Analog input pin 4	AN_4	Input	Group 1 analog inputs
Analog input pin 5	AN_5	Input	
Analog input pin 6	AN_6	Input	
Analog input pin 7	AN_7	Input	
A/D external trigger input pin	\overline{ADTRG}	Input	External trigger input for starting A/D conversion

15.1.4 Register Configuration

Table 15.2 summarizes the A/D converter's registers.

Table 15.2 A/D Converter Registers

Address ^{*1}	Name	Abbreviation	R/W	Initial Value
H'FFE0	A/D data register A (high)	ADDRAH	R	H'00
H'FFE1	A/D data register A (low)	ADDRAL	R	H'00
H'FFE2	A/D data register B (high)	ADDRBH	R	H'00
H'FFE3	A/D data register B (low)	ADDRBL	R	H'00
H'FFE4	A/D data register C (high)	ADDRCH	R	H'00
H'FFE5	A/D data register C (low)	ADDRCL	R	H'00
H'FFE6	A/D data register D (high)	ADDRDH	R	H'00
H'FFE7	A/D data register D (low)	ADDRDL	R	H'00
H'FFE8	A/D control/status register	ADCSR	R/(W) ^{*2}	H'00
H'FFE9	A/D control register	ADCR	R/W	H'7E ^{*3}

- Notes:
1. Lower 16 bits of the address
 2. Only 0 can be written in bit 7, to clear the flag.
 3. Initial value is H'7F in mask ROM versions, PROM versions, and dual power supply flash memory versions.

15.2 Register Descriptions

15.2.1 A/D Data Registers A to D (ADDRA to ADDR D)

Bit	15	14	13	12	11	10	9	8	7	6	5	4	3	2	1	0
ADDR _n	AD9	AD8	AD7	AD6	AD5	AD4	AD3	AD2	AD1	AD0	—	—	—	—	—	—
Initial value	0	0	0	0	0	0	0	0	0	0	0	0	0	0	0	0
Read/Write (n = A to D)	R	R	R	R	R	R	R	R	R	R	R	R	R	R	R	R
	A/D conversion data 10-bit data giving an A/D conversion result										Reserved bits					

The four A/D data registers (ADDRA to ADDR D) are 16-bit read-only registers that store the results of A/D conversion.

An A/D conversion produces 10-bit data, which is transferred for storage into the A/D data register corresponding to the selected channel. The upper 8 bits of the result are stored in the upper byte of the A/D data register. The lower 2 bits are stored in the lower byte. Bits 5 to 0 of an A/D data register are reserved bits that are always read as 0. Table 15.3 indicates the pairings of analog input channels and A/D data registers.

The CPU can always read and write the A/D data registers. The upper byte can be read directly, but the lower byte is read through a temporary register (TEMP). For details see section 15.3, CPU Interface.

The A/D data registers are initialized to H'0000 by a reset and in standby mode.

Table 15.3 Analog Input Channels and A/D Data Registers

Analog Input Channel		A/D Data Register
Group 0	Group 1	
AN ₀	AN ₄	ADDRA
AN ₁	AN ₅	ADDRB
AN ₂	AN ₆	ADDRC
AN ₃	AN ₇	ADDRD

15.2.2 A/D Control/Status Register (ADCSR)

Bit	7	6	5	4	3	2	1	0
	ADF	ADIE	ADST	SCAN	CKS	CH2	CH1	CH0
Initial value	0	0	0	0	0	0	0	0
Read/Write	R/(W)*	R/W	R/W	R/W	R/W	R/W	R/W	R/W

A/D end flag
 Indicates end of A/D conversion

A/D interrupt enable
 Enables and disables A/D end interrupts

A/D start
 Starts or stops A/D conversion

Scan mode
 Selects single mode or scan mode

Clock select
 Selects the A/D conversion time

Channel select 2 to 0
 These bits select analog input channels

Note: * Only 0 can be written, to clear the flag.

ADCSR is an 8-bit readable/writable register that selects the mode and controls the A/D converter. ADCSR is initialized to H'00 by a reset and in standby mode.

Bit 7—A/D End Flag (ADF): Indicates the end of A/D conversion.

Bit 7: ADF	Description
0	[Clearing condition] Cleared by reading ADF while ADF = 1, then writing 0 in ADF (Initial value)
1	[Setting conditions] Single mode: A/D conversion ends Scan mode: A/D conversion ends in all selected channels

Bit 6—A/D Interrupt Enable (ADIE): Enables or disables the interrupt (ADI) requested at the end of A/D conversion.

Bit 6: ADIE	Description
0	A/D end interrupt request (ADI) is disabled (Initial value)
1	A/D end interrupt request (ADI) is enabled

Bit 5—A/D Start (ADST): Starts or stops A/D conversion. The ADST bit remains set to 1 during A/D conversion. It can also be set to 1 by external trigger input at the ADTRG pin.

Bit 5: ADST	Description
0	A/D conversion is stopped (Initial value)
1	Single mode: A/D conversion starts; ADST is automatically cleared to 0 when conversion ends. Scan mode: A/D conversion starts and continues, cycling among the selected channels, until ADST is cleared to 0 by software, by a reset, or by a transition to standby mode.

Bit 4—Scan Mode (SCAN): Selects single mode or scan mode. For further information on operation in these modes, see section 15.4, Operation. Clear the ADST bit to 0 before switching the conversion mode.

Bit 4: SCAN	Description
0	Single mode (Initial value)
1	Scan mode

Bit 3—Clock Select (CKS): Selects the A/D conversion time. Clear the ADST bit to 0 before switching the conversion time.

Bit 3: CKS	Description
0	Conversion time = 266 states (maximum) (Initial value)
1	Conversion time = 134 states (maximum)

Bits 2 to 0—Channel Select 2 to 0 (CH2 to CH0): These bits and the SCAN bit select the analog input channels. Clear the ADST bit to 0 before changing the channel selection.

Group Selection	Channel Selection		Description	
	CH2	CH1	CH0	
0	0	0	Single Mode	AN ₀ (Initial value)
		1	Scan Mode	AN ₀
	1	0	Single Mode	AN ₀ , AN ₁
		1	Scan Mode	AN ₀ to AN ₂
1	0	0	Single Mode	AN ₃
		1	Scan Mode	AN ₀ to AN ₃
	1	0	Single Mode	AN ₄
		1	Scan Mode	AN ₄ , AN ₅
1	0	0	Single Mode	AN ₆
		1	Scan Mode	AN ₄ to AN ₆
		1	Single Mode	AN ₇
		1	Scan Mode	AN ₄ to AN ₇

15.2.3 A/D Control Register (ADCR)

Bit	7	6	5	4	3	2	1	0
	TRGE	—	—	—	—	—	—	—
Initial value	0	1	1	1	1	1	1	0
Read/Write	R/W	—	—	—	—	—	—	—

Reserved bits

Trigger enable
Enables or disables external triggering of A/D conversion

Reserved bit
Must not be set to 1

ADCR is an 8-bit readable/writable register that enables or disables external triggering of A/D conversion. ADCR is initialized to H'7E by a reset and in standby mode.

Bit 7—Trigger Enable (TRGE): Enables or disables external triggering of A/D conversion.

Bit 7: TRGE	Description
0	A/D conversion cannot be externally triggered (Initial value)
1	A/D conversion starts at the falling edge of the external trigger signal ($\overline{\text{ADTRG}}$)

Bits 6 to 1—Reserved: Read-only bits, always read as 1.

Bit 0—Reserved: Do not set to 1.

15.3 CPU Interface

ADDRA to ADDR_D are 16-bit registers, but they are connected to the CPU by an 8-bit data bus. Therefore, although the upper byte can be accessed directly by the CPU, the lower byte is read through an 8-bit temporary register (TEMP).

An A/D data register is read as follows. When the upper byte is read, the upper-byte value is transferred directly to the CPU and the lower-byte value is transferred into TEMP. Next, when the lower byte is read, the TEMP contents are transferred to the CPU.

When reading an A/D data register, always read the upper byte before the lower byte. It is possible to read only the upper byte, but if only the lower byte is read, incorrect data may be obtained.

Figure 15.2 shows the data flow for access to an A/D data register.

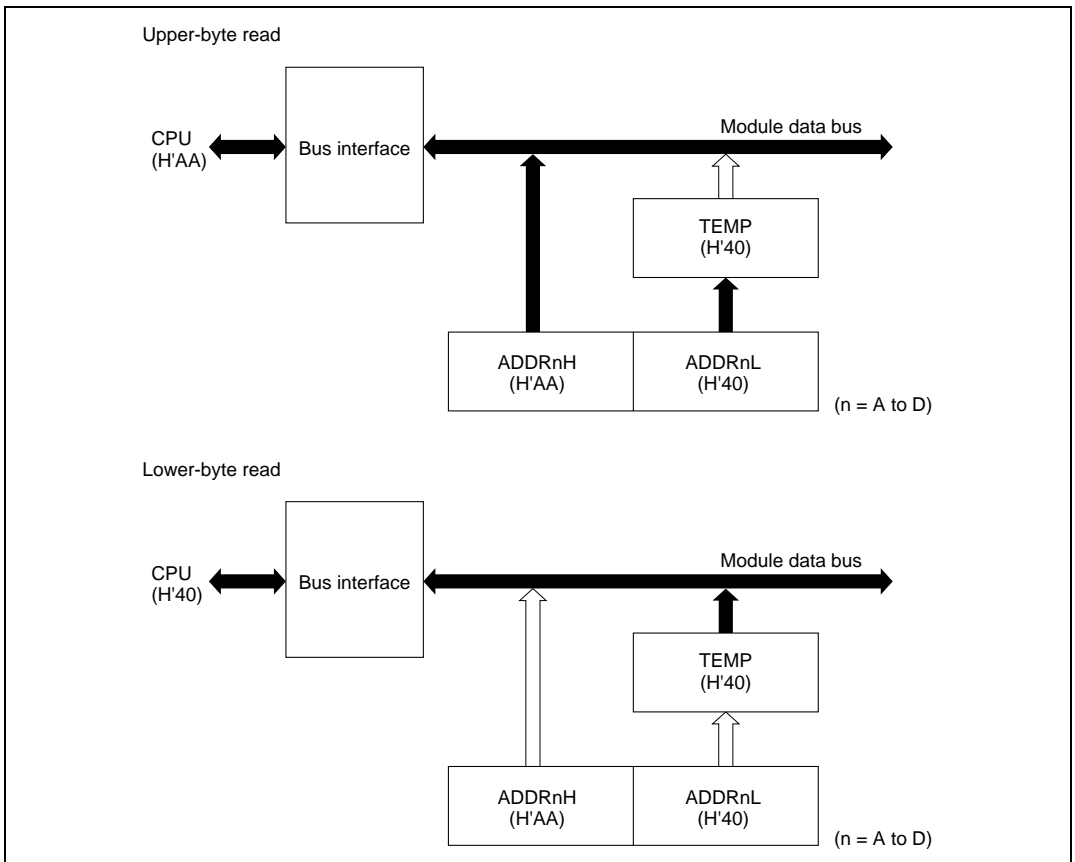

Figure 15.2 A/D Data Register Access Operation (Reading H'AA40)

15.4 Operation

The A/D converter operates by successive approximations with 10-bit resolution. It has two operating modes: single mode and scan mode.

15.4.1 Single Mode (SCAN = 0)

Single mode should be selected when only one A/D conversion on one channel is required. A/D conversion starts when the ADST bit is set to 1 by software, or by external trigger input. The ADST bit remains set to 1 during A/D conversion and is automatically cleared to 0 when conversion ends.

When conversion ends the ADF bit is set to 1. If the ADIE bit is also set to 1, an ADI interrupt is requested at this time. To clear the ADF flag to 0, first read ADCSR, then write 0 in ADF.

When the mode or analog input channel must be switched during analog conversion, to prevent incorrect operation, first clear the ADST bit to 0 in ADCSR to halt A/D conversion. After making the necessary changes, set the ADST bit to 1 to start A/D conversion again. The ADST bit can be set at the same time as the mode or channel is changed.

Typical operations when channel 1 (AN_1) is selected in single mode are described next.

Figure 15.3 shows a timing diagram for this example.

1. Single mode is selected (SCAN = 0), input channel AN_1 is selected (CH2 = CH1 = 0, CH0 = 1), the A/D interrupt is enabled (ADIE = 1), and A/D conversion is started (ADST = 1).
2. When A/D conversion is completed, the result is transferred into ADDR0. At the same time the ADF flag is set to 1, the ADST bit is cleared to 0, and the A/D converter becomes idle.
3. Since ADF = 1 and ADIE = 1, an ADI interrupt is requested.
4. The A/D interrupt handling routine starts.
5. The routine reads ADCSR, then writes 0 in the ADF flag.
6. The routine reads and processes the conversion result (ADDR0).
7. Execution of the A/D interrupt handling routine ends. After that, if the ADST bit is set to 1, A/D conversion starts again and steps 2 to 7 are repeated.

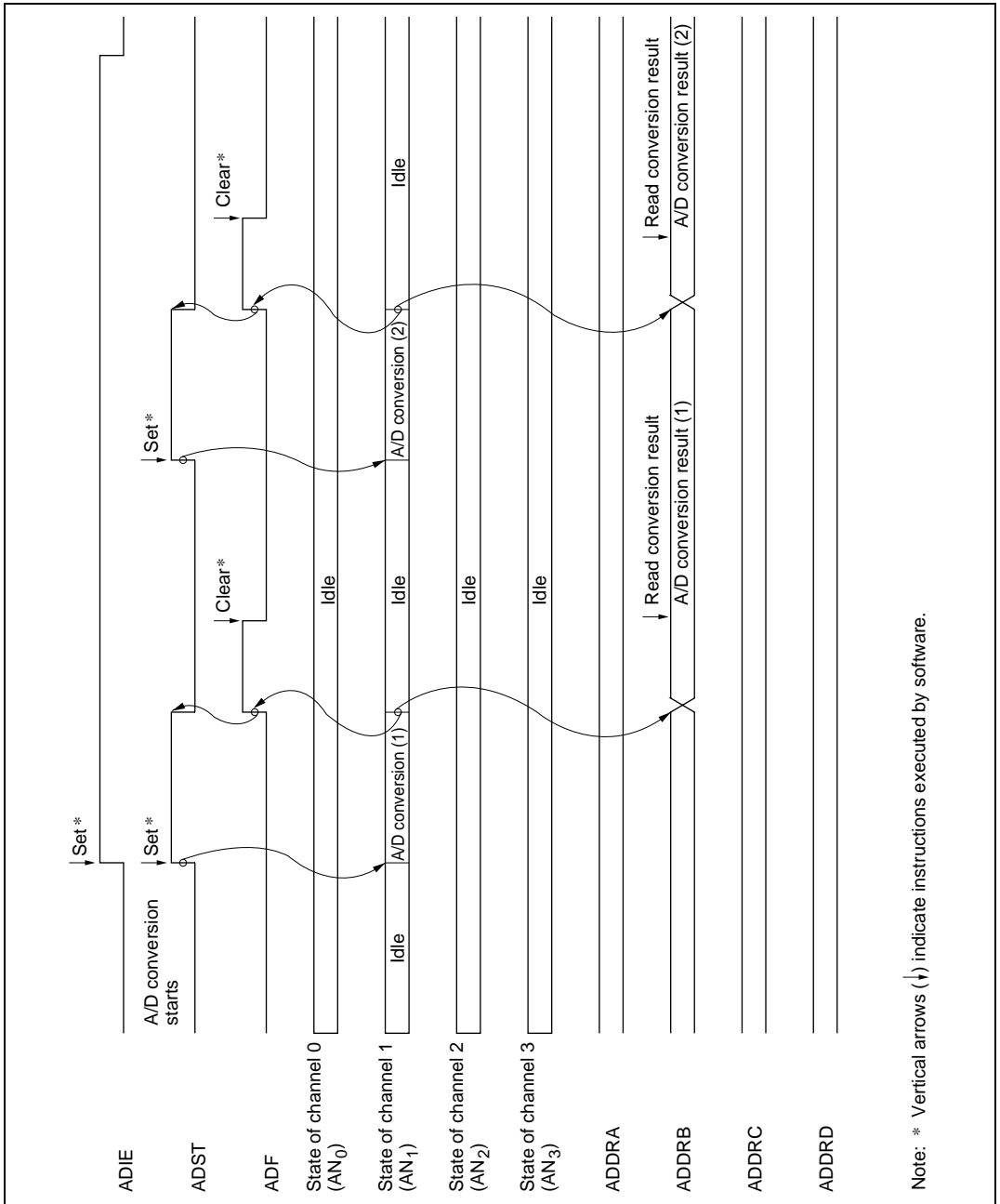

Figure 15.3 Example of A/D Converter Operation (Single Mode, Channel 1 Selected)

15.4.2 Scan Mode (SCAN = 1)

Scan mode is useful for monitoring analog inputs in a group of one or more channels. When the ADST bit is set to 1 by software or external trigger input, A/D conversion starts on the first channel in the group (AN_0 when $CH2 = 0$, AN_4 when $CH2 = 1$). When two or more channels are selected, after conversion of the first channel ends, conversion of the second channel (AN_1 or AN_5) starts immediately. A/D conversion continues cyclically on the selected channels until the ADST bit is cleared to 0. The conversion results are transferred for storage into the A/D data registers corresponding to the channels.

When the mode or analog input channel selection must be changed during analog conversion, to prevent incorrect operation, first clear the ADST bit to 0 in ADCSR to halt A/D conversion. After making the necessary changes, set the ADST bit to 1. A/D conversion will start again from the first channel in the group. The ADST bit can be set at the same time as the mode or channel selection is changed.

Typical operations when three channels in group 0 (AN_0 to AN_2) are selected in scan mode are described next. Figure 15.4 shows a timing diagram for this example.

1. Scan mode is selected ($SCAN = 1$), scan group 0 is selected ($CH2 = 0$), analog input channels AN_0 to AN_2 are selected ($CH1 = 1$, $CH0 = 0$), and A/D conversion is started ($ADST = 1$).
2. When A/D conversion of the first channel (AN_0) is completed, the result is transferred into ADDRA. Next, conversion of the second channel (AN_1) starts automatically.
3. Conversion proceeds in the same way through the third channel (AN_2).
4. When conversion of all selected channels (AN_0 to AN_2) is completed, the ADF flag is set to 1 and conversion of the first channel (AN_0) starts again. If the ADIE bit is set to 1, an ADI interrupt is requested at this time.
5. Steps 2 to 4 are repeated as long as the ADST bit remains set to 1. When the ADST bit is cleared to 0, A/D conversion stops. After that, if the ADST bit is set to 1, A/D conversion starts again from the first channel (AN_0).

15.4.3 Input Sampling and A/D Conversion Time

The A/D converter has a built-in sample-and-hold circuit. The A/D converter samples the analog input at a time t_D after the ADST bit is set to 1, then starts conversion. Figure 15.5 shows the A/D conversion timing. Table 15.4 indicates the A/D conversion time.

As indicated in figure 15.5, the A/D conversion time includes t_D and the input sampling time. The length of t_D varies depending on the timing of the write access to ADCSR. The total conversion time therefore varies within the ranges indicated in table 15.4.

In scan mode, the values given in table 15.4 apply to the first conversion. In the second and subsequent conversions the conversion time is fixed at 256 states when $CKS = 0$ or 128 states when $CKS = 1$.

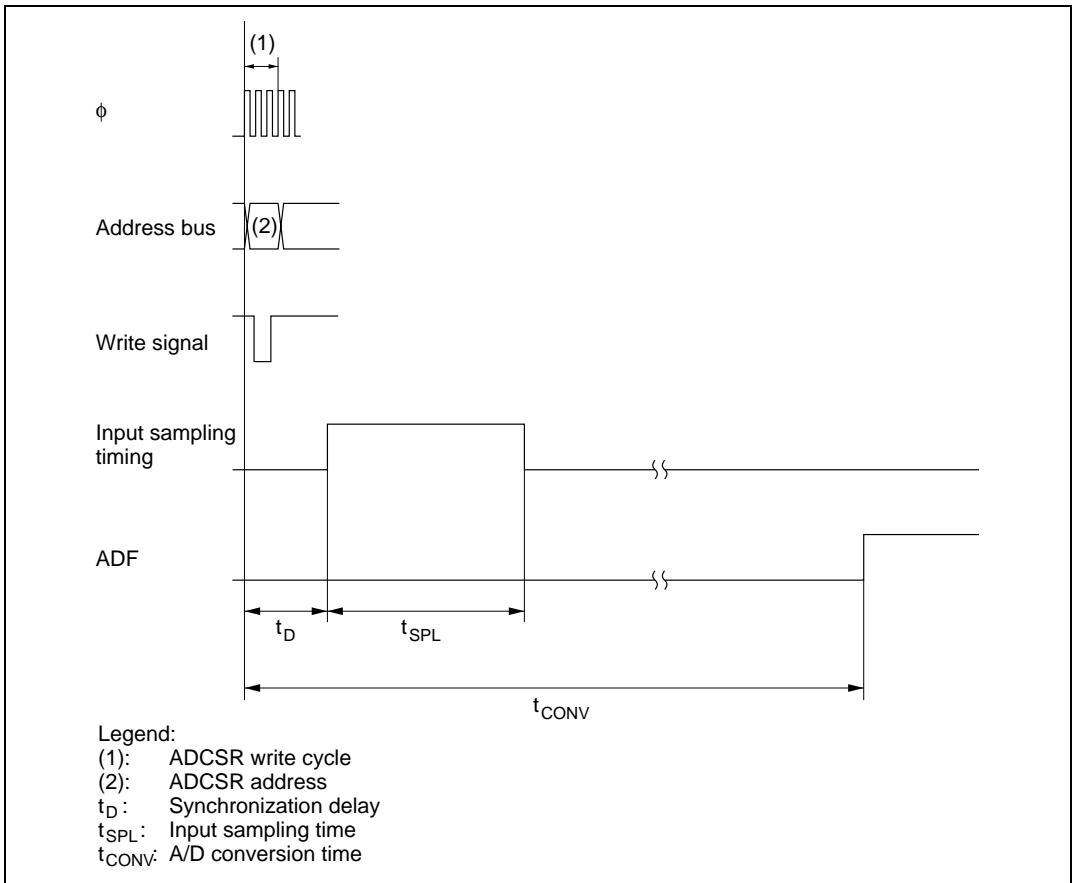

Figure 15.5 A/D Conversion Timing

Table 15.4 A/D Conversion Time (Single Mode)

	Symbol	CKS = 0			CKS = 1		
		Min	Typ	Max	Min	Typ	Max
Synchronization delay	t_d	10	—	17	6	—	9
Input sampling time	t_{SPL}	—	63	—	—	31	—
A/D conversion time	t_{CONV}	259	—	266	131	—	134

Note: Values in the table are numbers of states.

15.4.4 External Trigger Input Timing

A/D conversion can be externally triggered. When the TRGE bit is set to 1 in ADCR, external trigger input is enabled at the \overline{ADTRG} pin. A high-to-low transition at the \overline{ADTRG} pin sets the ADST bit to 1 in ADCSR, starting A/D conversion. Other operations, in both single and scan modes, are the same as if the ADST bit had been set to 1 by software. Figure 15.6 shows the timing.

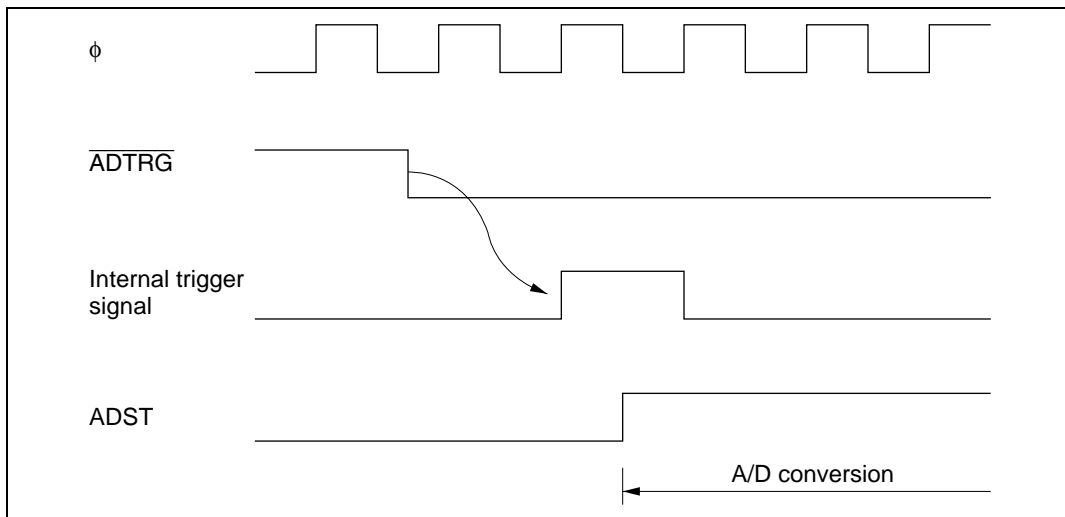
**Figure 15.6 External Trigger Input Timing**

15.5 Interrupts

The A/D converter generates an interrupt (ADI) at the end of A/D conversion. The ADI interrupt request can be enabled or disabled by the ADIE bit in ADCSR.

15.6 Usage Notes

When using the A/D converter, note the following points:

1. **Analog Input Voltage Range:** During A/D conversion, the voltages input to the analog input pins should be in the range $AV_{SS} \leq AN_n \leq V_{REF}$.
2. **Relationships of AV_{CC} and AV_{SS} to V_{CC} and V_{SS} :** AV_{CC} , AV_{SS} , V_{CC} , and V_{SS} should be related as follows: $AV_{SS} = V_{SS}$. AV_{CC} and AV_{SS} must not be left open, even if the A/D converter is not used.
3. **V_{REF} Programming Range:** The reference voltage input at the V_{REF} pin should be in the range $V_{REF} \leq AV_{CC}$.

Failure to observe points 1, 2, and 3 above may degrade chip reliability.

4. **Note on Board Design:** In board layout, separate the digital circuits from the analog circuits as much as possible. Particularly avoid layouts in which the signal lines of digital circuits cross or closely approach the signal lines of analog circuits. Induction and other effects may cause the analog circuits to operate incorrectly, or may adversely affect the accuracy of A/D conversion. The analog input signals (AN_0 to AN_7), analog reference voltage (V_{REF}), and analog supply voltage (AV_{CC}) must be separated from digital circuits by the analog ground (AV_{SS}). The analog ground (AV_{SS}) should be connected to a stable digital ground (V_{SS}) at one point on the board.

5. Note on Noise: To prevent damage from surges and other abnormal voltages at the analog input pins (AN_0 to AN_7) and analog reference voltage pin (V_{REF}), connect a protection circuit like the one in figure 15.7 between AV_{CC} and AV_{SS} . The bypass capacitors connected to AV_{CC} and V_{REF} and the filter capacitors connected to AN_0 to AN_7 must be connected to AV_{SS} . If filter capacitors like the ones in figure 15.7 are connected, the voltage values input to the analog input pins (AN_0 to AN_7) will be smoothed, which may give rise to error. Error can also occur if A/D conversion is frequently performed in scan mode so that the current that charges and discharges the capacitor in the sample-and-hold circuit of the A/D converter becomes greater than that input to the analog input pins via input impedance R_{in} . The circuit constants should therefore be selected carefully.

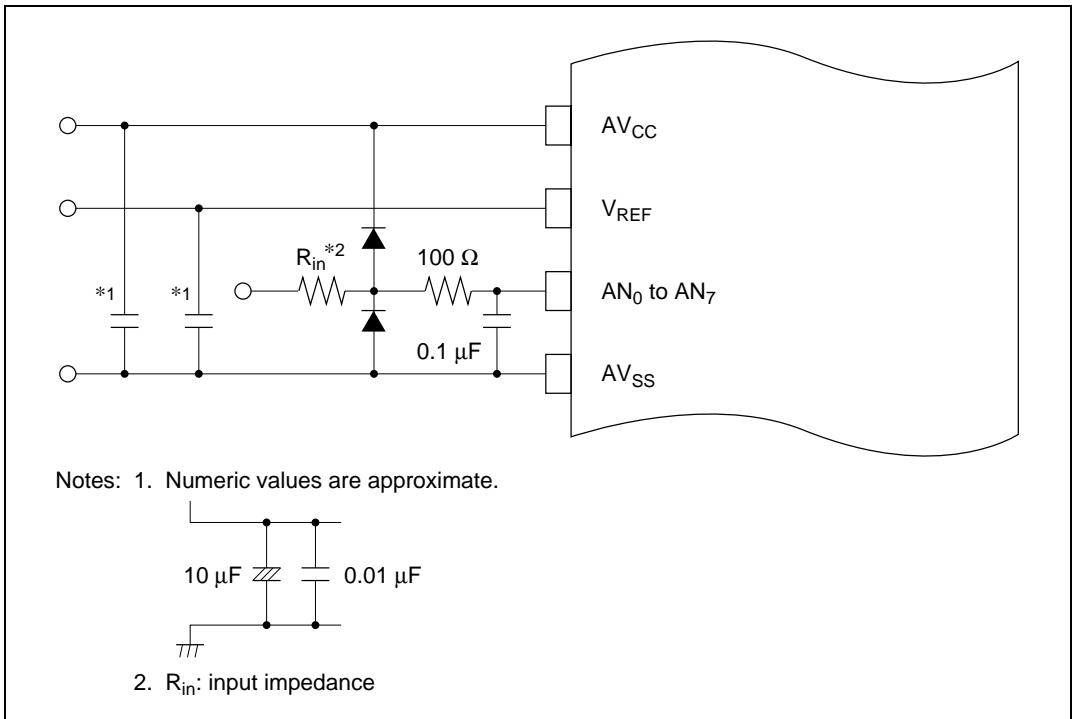
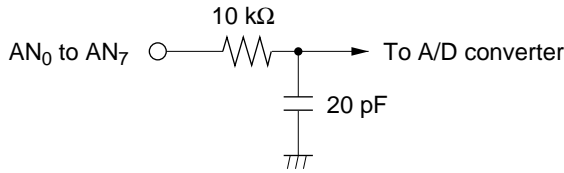

Figure 15.7 Example of Analog Input Protection Circuit



Note: Numeric values are approximate.

Figure 15.8 Analog Input Pin Equivalent Circuit

Table 15.5 Analog Input Pin Ratings

Item		Min	Max	Unit
Analog input capacitance		—	20	pF
Allowable signal-source impedance	$\phi \leq 13\text{ MHz}$	—	10	k Ω
	$\phi > 13\text{ MHz}$	—	5	k Ω

6. A/D Conversion Accuracy Definitions: A/D conversion accuracy in the H8/3048B Group is defined as follows:

- Resolution
Digital output code length of A/D converter
- Offset error
Deviation from ideal A/D conversion characteristic of analog input voltage required to raise digital output from minimum voltage value B'0000000000 to B'0000000001 (figure 15.10)
- Full-scale error
Deviation from ideal A/D conversion characteristic of analog input voltage required to raise digital output from B'1111111110 to B'1111111111 (figure 15.10)
- Quantization error
Intrinsic error of the A/D converter; 1/2 LSB (figure 15.9)
- Nonlinearity error
Deviation from ideal A/D conversion characteristic in range from zero volts to full scale, exclusive of offset error, full-scale error, and quantization error.
- Absolute accuracy
Deviation of digital value from analog input value, including offset error, full-scale error, quantization error, and nonlinearity error.

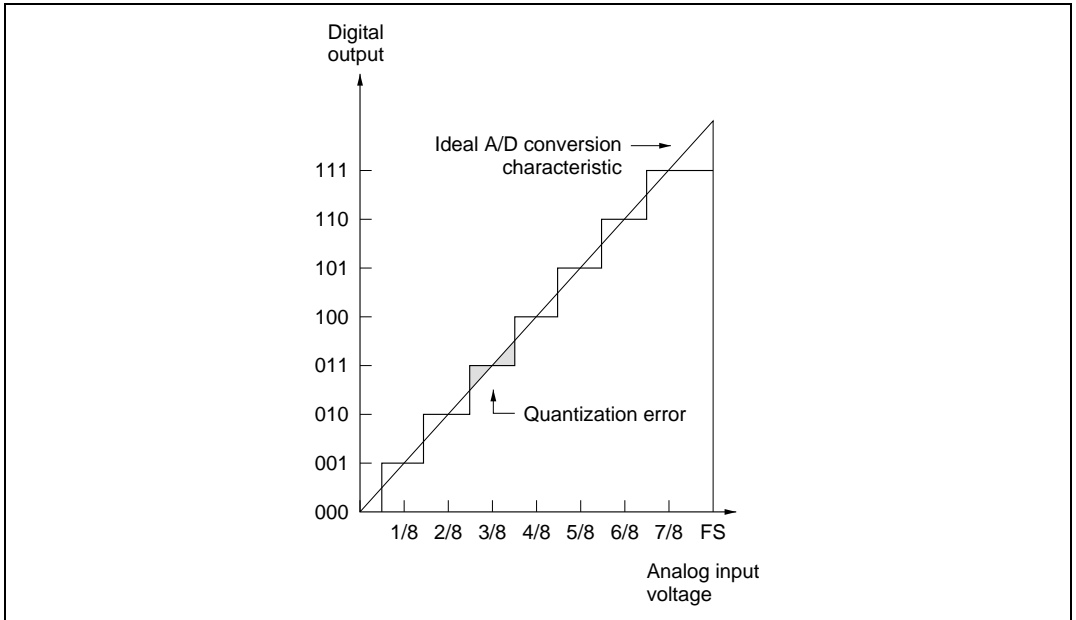

Figure 15.9 A/D Converter Accuracy Definitions (1)

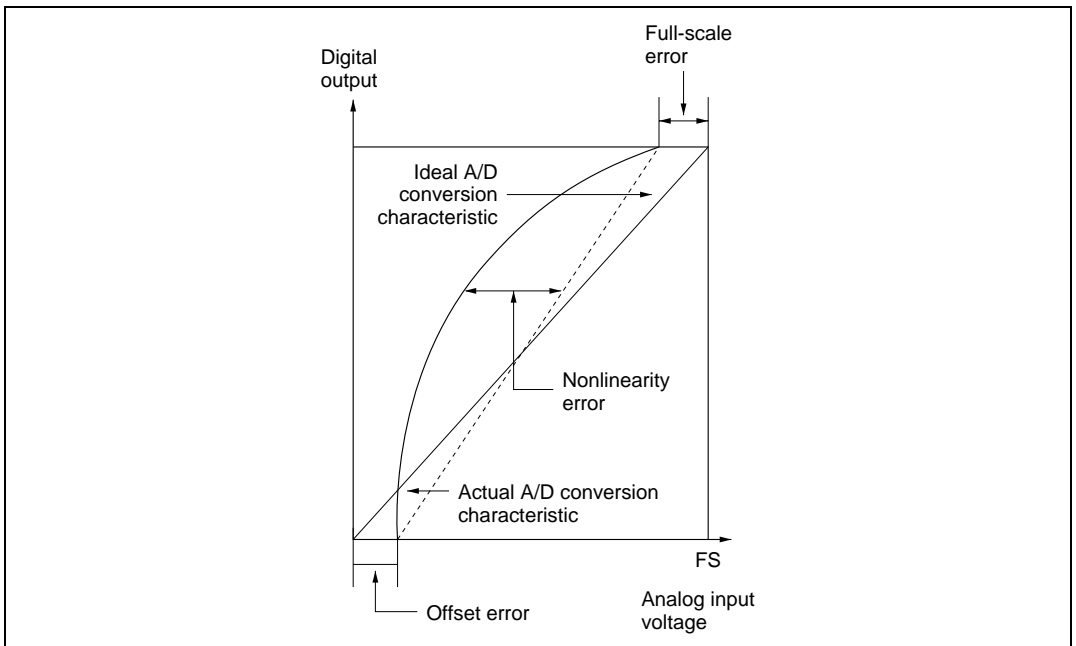

Figure 15.10 A/D Converter Accuracy Definitions (2)

7. Allowable Signal-Source Impedance: The analog inputs of the H8/3048B Group are designed to assure accurate conversion of input signals with a signal-source impedance not exceeding $10\text{ k}\Omega$ ($\phi \leq 13\text{ MHz}$) or not exceeding $5\text{ k}\Omega$ ($\phi > 13\text{ MHz}$) (table 15.5). The reason for this rating is that it enables the input capacitor in the sample-and-hold circuit in the A/D converter to charge within the sampling time. If the sensor output impedance exceeds $10\text{ k}\Omega$, charging may be inadequate and the accuracy of A/D conversion cannot be guaranteed.

If a large external capacitor is provided in scan mode, then the internal $10\text{-k}\Omega$ input resistance becomes the only significant load on the input. In this case the impedance of the signal source is not a problem.

A large external capacitor, however, acts as a low-pass filter. This may make it impossible to track analog signals with high dv/dt (e.g. a variation of $5\text{ mV}/\mu\text{s}$) (figure 15.11). To convert high-speed analog signals or to use scan mode, insert a low-impedance buffer.

8. Effect on Absolute Accuracy: Attaching an external capacitor creates a coupling with ground, so if there is noise on the ground line, it may degrade absolute accuracy. The capacitor must be connected to an electrically stable ground, such as AV_{SS} .

If a filter circuit is used, be careful of interference with digital signals on the same board, and make sure the circuit does not act as an antenna.

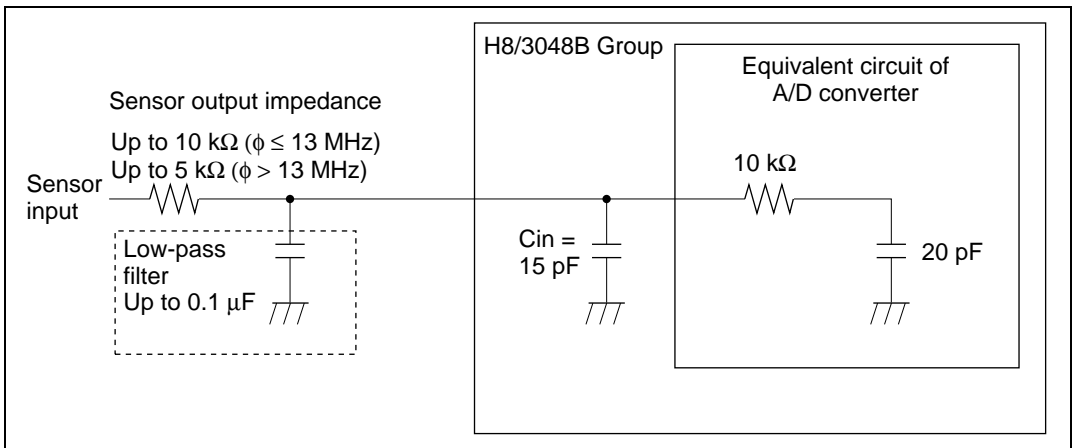

Figure 15.11 Analog Input Circuit (Example)

Section 16 D/A Converter

16.1 Overview

The H8/3048B Group includes a D/A converter with two channels.

16.1.1 Features

D/A converter features are listed below.

- Eight-bit resolution
- Two output channels
- Conversion time: maximum 10 μ s (with 20-pF capacitive load)
- Output voltage: 0 V to $255/256 \times V_{REF}$
- D/A outputs can be sustained in software standby mode

16.1.2 Block Diagram

Figure 16.1 shows a block diagram of the D/A converter.

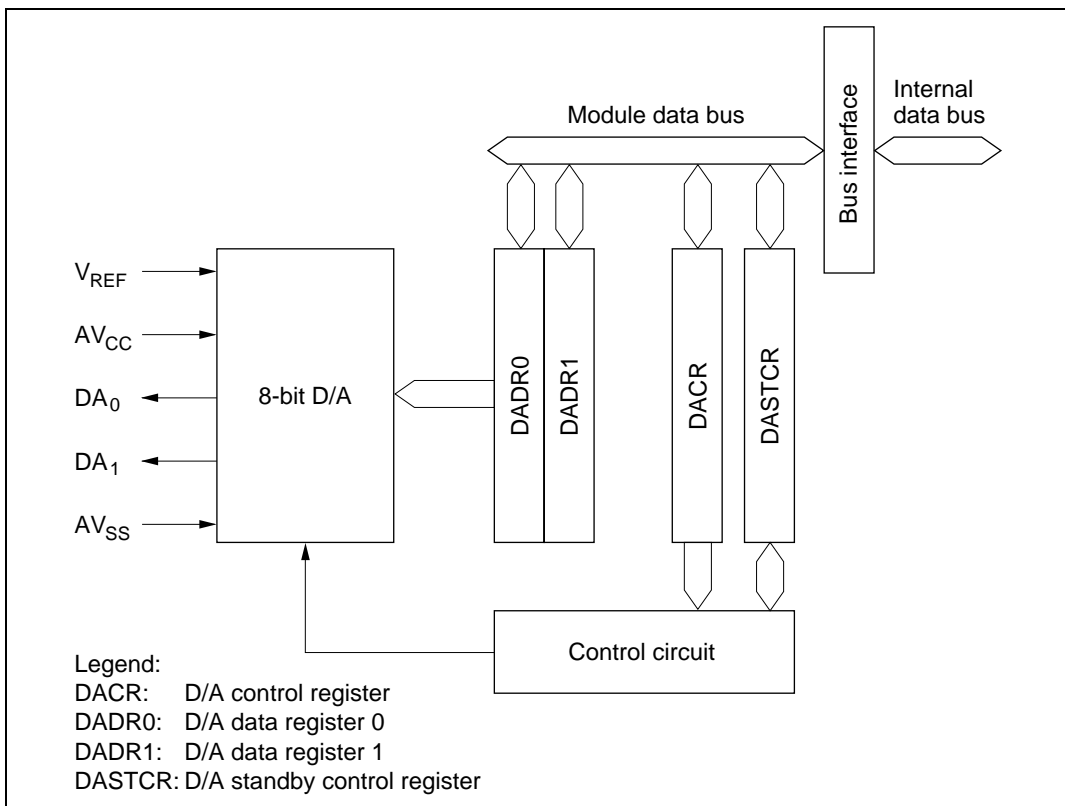

Figure 16.1 D/A Converter Block Diagram

16.1.3 Input/Output Pins

Table 16.1 summarizes the D/A converter's input and output pins.

Table 16.1 D/A Converter Pins

Pin Name	Abbreviation	I/O	Function
Analog power supply pin	AV_{CC}	Input	Analog power supply
Analog ground pin	AV_{SS}	Input	Analog ground and reference voltage
Analog output pin 0	DA_0	Output	Analog output, channel 0
Analog output pin 1	DA_1	Output	Analog output, channel 1
Reference voltage input pin	V_{REF}	Input	Analog reference voltage

16.1.4 Register Configuration

Table 16.2 summarizes the D/A converter's registers.

Table 16.2 D/A Converter Registers

Address*	Name	Abbreviation	R/W	Initial Value
H'FFDC	D/A data register 0	DADR0	R/W	H'00
H'FFDD	D/A data register 1	DADR1	R/W	H'00
H'FFDE	D/A control register	DACR	R/W	H'1F
H'FF5C	D/A standby control register	DASTCR	R/W	H'FE

Note: * Lower 16 bits of the address

16.2 Register Descriptions

16.2.1 D/A Data Registers 0 and 1 (DADR0, DADR1)

Bit	7	6	5	4	3	2	1	0
Initial value	0	0	0	0	0	0	0	0
Read/Write	R/W	R/W	R/W	R/W	R/W	R/W	R/W	R/W

The D/A data registers (DADR0 and DADR1) are 8-bit readable/writable registers that store the data to be converted. When analog output is enabled, the D/A data register values are constantly converted and output at the analog output pins.

The D/A data registers are initialized to H'00 by a reset and in standby mode.

16.2.2 D/A Control Register (DACR)

Bit	7	6	5	4	3	2	1	0
	DAOE1	DAOE0	DAE	—	—	—	—	—
Initial value	0	0	0	1	1	1	1	1
Read/Write	R/W	R/W	R/W	—	—	—	—	—

D/A enable
 Controls D/A conversion

D/A output enable 0
 Controls D/A conversion and analog output

D/A output enable 1
 Controls D/A conversion and analog output

DACR is an 8-bit readable/writable register that controls the operation of the D/A converter. DACR is initialized to H'1F by a reset and in standby mode.

Bit 7—D/A Output Enable 1 (DAOE1): Controls D/A conversion and analog output.

Bit 7: DAOE1	Description
0	DA ₁ analog output is disabled (Initial value)
1	Channel-1 D/A conversion and DA ₁ analog output are enabled

Bit 6—D/A Output Enable 0 (DAOE0): Controls D/A conversion and analog output.

Bit 6: DAOE0	Description
0	DA ₀ analog output is disabled (Initial value)
1	Channel-0 D/A conversion and DA ₀ analog output are enabled

Bit 5—D/A Enable (DAE): Controls D/A conversion, together with bits DAOE0 and DAOE1. When the DAE bit is cleared to 0, analog conversion is controlled independently in channels 0 and 1. When the DAE bit is set to 1, analog conversion is controlled together in channels 0 and 1. Output of the conversion results is always controlled independently by DAOE0 and DAOE1.

Bit 7: DAOE1	Bit 6: DAOE0	Bit 5: DAE	Description
0	0	—	D/A conversion is disabled in channels 0 and 1
		1	D/A conversion is enabled in channel 0 D/A conversion is disabled in channel 1
	1	0	D/A conversion is disabled in channel 0 D/A conversion is enabled in channel 1
		1	D/A conversion is enabled in channels 0 and 1
1	0	0	D/A conversion is disabled in channel 0 D/A conversion is enabled in channel 1
		1	D/A conversion is enabled in channels 0 and 1
	1	0	D/A conversion is disabled in channel 0 D/A conversion is enabled in channel 1
		1	—

When the DAE bit is set to 1, even if bits DAOE0 and DAOE1 in DACR and the ADST bit in ADCSR are cleared to 0, the same current is drawn from the analog power supply as during A/D and D/A conversion.

Bits 4 to 0—Reserved: Read-only bits, always read as 1.

16.2.3 D/A Standby Control Register (DASTCR)

DASTCR is an 8-bit readable/writable register that enables or disables D/A output in software standby mode.

Bit	7	6	5	4	3	2	1	0
	—	—	—	—	—	—	—	DASTE
Initial value	1	1	1	1	1	1	1	0
Read/Write	—	—	—	—	—	—	—	R/W

Reserved bits

D/A standby enable
Enables or disables D/A output
in software standby mode

DASTCR is initialized to H'FE by a reset and in hardware standby mode. It is not initialized in software standby mode.

Bits 7 to 1—Reserved: Read-only bits, always read as 1.

Bit 0—D/A Standby Enable (DASTE): Enables or disables D/A output in software standby mode.

Bit 0: DASTE	Description	
0	D/A output is disabled in software standby mode	(Initial value)
1	D/A output is enabled in software standby mode	

16.3 Operation

The D/A converter has two built-in D/A conversion circuits that can perform conversion independently.

D/A conversion is performed constantly while enabled in DACR. If the DADR0 or DADR1 value is modified, conversion of the new data begins immediately. The conversion results are output when bits DAOE0 and DAOE1 are set to 1.

An example of D/A conversion on channel 0 is given next. Timing is indicated in figure 16.2.

1. Data to be converted is written in DADR0.
2. Bit DAOE0 is set to 1 in DACR. D/A conversion starts and DA_0 becomes an output pin. The converted result is output after the conversion time. The output value is $(DADR0 \text{ contents}/256) \times V_{REF}$. Output of this conversion result continues until the value in DADR0 is modified or the DAOE0 bit is cleared to 0.
3. If the DADR0 value is modified, conversion starts immediately, and the result is output after the conversion time.
4. When the DAOE0 bit is cleared to 0, DA_0 becomes an input pin.

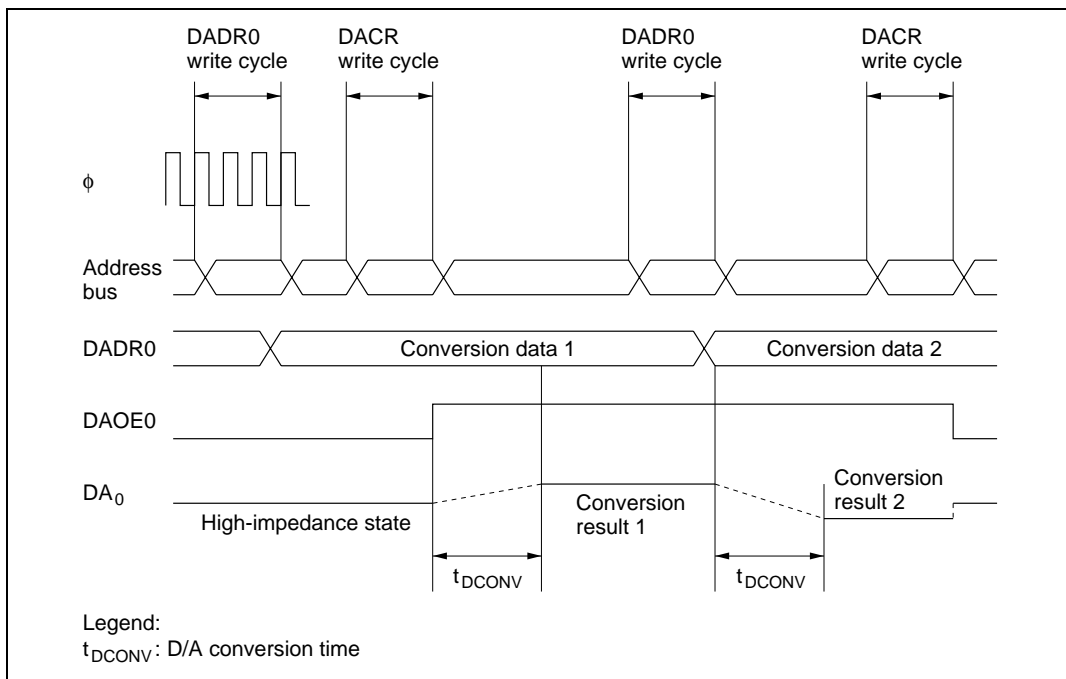

Figure 16.2 Example of D/A Converter Operation

16.4 D/A Output Control

In the H8/3048B Group, D/A converter output can be enabled or disabled in software standby mode.

When the DASTE bit is set to 1 in DASTCR, D/A converter output is enabled in software standby mode. The D/A converter registers retain the values they held prior to the transition to software standby mode.

When D/A output is enabled in software standby mode, the reference supply current is the same as during normal operation.

Section 17 RAM

17.1 Overview

The H8/3048B Group has 4 kbytes of high-speed static RAM on-chip. The RAM is connected to the CPU by a 16-bit data bus. The CPU accesses both byte data and word data in two states, making the RAM useful for rapid data transfer.

The on-chip RAM of the H8/3048B Group is assigned to addresses H'FEF10 to H'FFF0F in modes 1, 2, 5, and 7, and to addresses H'FFE10 to H'FFF0F in modes 3, 4, and 6. The RAM enable bit (RAME) in the system control register (SYSCR) can enable or disable the on-chip RAM.

17.1.1 Block Diagram

Figure 17.1 shows a block diagram of the on-chip RAM.

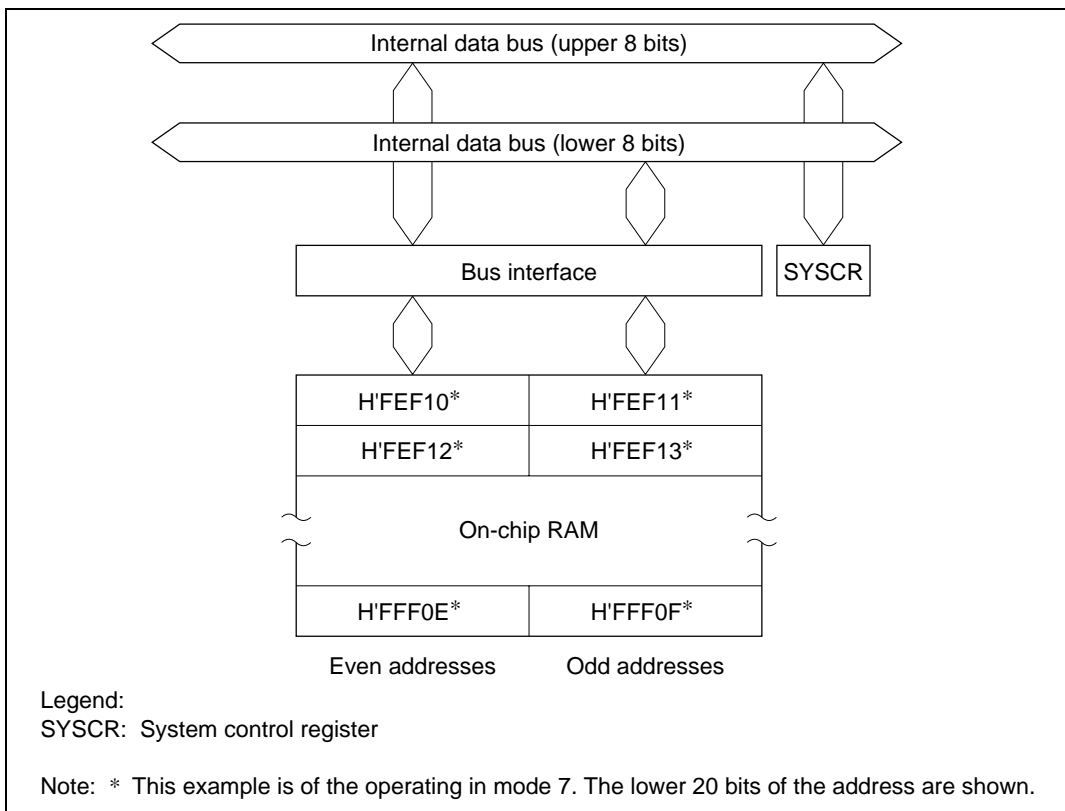

Figure 17.1 RAM Block Diagram

17.1.2 Register Configuration

The on-chip RAM is controlled by SYSCR. Table 17.1 gives the address and initial value of SYSCR.

Table 17.1 System Control Register

Address*	Name	Abbreviation	R/W	Initial Value
H'FFF2	System control register	SYSCR	R/W	H'0B

Note: * Lower 16 bits of the address.

17.2 System Control Register (SYSCR)

Bit	7	6	5	4	3	2	1	0
	SSBY	STS2	STS1	STS0	UE	NMIEG	—	RAME
Initial value	0	0	0	0	1	0	1	1
Read/Write	R/W	R/W	R/W	R/W	R/W	R/W	—	R/W

Software standby
 Standby timer select 2 to 0
 User bit enable
 NMI edge select
 Reserved bit
 RAM enable
 Enables or disables on-chip RAM

One function of SYSCR is to enable or disable access to the on-chip RAM. The on-chip RAM is enabled or disabled by the RAME bit in SYSCR. For details about the other bits, see section 3.3, System Control Register (SYSCR).

Bit 0—RAM Enable (RAME): Enables or disables the on-chip RAM. The RAME bit is initialized at the rising edge of the input at the $\overline{\text{RES}}$ pin. It is not initialized in software standby mode.

Bit 0: RAME	Description
0	On-chip RAM is disabled
1	On-chip RAM is enabled (Initial value)

17.3 Operation

When the RAME bit is set to 1, the on-chip RAM is enabled. Accesses to addresses H'FEF10 to H'FFF0F in the H8/3048B Group in modes 1, 2, 5, and 7, addresses H'FFE10 to H'FFFF0F in the H8/3048B Group in modes 3, 4, and 6 are directed to the on-chip RAM. In modes 1 to 6 (expanded modes), when the RAME bit is cleared to 0, the off-chip address space is accessed. In mode 7 (single-chip mode), when the RAME bit is cleared to 0, the on-chip RAM is not accessed: read access always results in H'FF data, and write access is ignored.

Since the on-chip RAM is connected to the CPU by an internal 16-bit data bus, it can be written and read by word access. It can also be written and read by byte access. Byte data is accessed in two states using the upper 8 bits of the data bus. Word data starting at an even address is accessed in two states using all 16 bits of the data bus.

Section 18 ROM

(H8/3048F-ONE: Single Power Supply, H8/3048B Mask ROM Version)

18.1 Flash Memory Overview

18.1.1 Notes on H8/3048F-ONE (Single Power Supply)

There are two models of the H8/3048F-ZTAT with on-chip flash memory: a dual power supply model (H8/3048F) and single power supply model (H8/3048F-ONE). Points to be noted when using the H8/3048F-ONE single power supply is given below.

For the differences between the dual power supply model and single power supply model (H8/3048F-ONE), see section 1.4.3, Differences between H8/3048F and H8/3048F-ONE.

(1) Voltage Application

12 V must not be applied to the H8/3048F-ONE (single power supply), as this will permanently damage the device.

The flash memory programming power supply for the H8/3048F-ONE (single power supply) is V_{cc} .

The programming power supply for the dual power supply model is the V_{pp} pin (12 V), but there is no V_{pp} pin in the single power supply model. In the H8/3048F-ONE (single power supply) model the FWE pin is provided at the same pin position as the V_{pp} pin in the dual power source model, but FWE is not a power supply pin—it is used to control flash memory write enabling.

Also, in boot mode, 12 V must be applied to the MD_2 pin in the dual power supply model, but this is not necessary in the H8/3048F-ONE (single power supply).

The maximum rating of the FWE and MD_2 pins in the H8/3048F-ONE (single power supply) is $V_{cc} + 0.3$ V. Applying a voltage in excess of the maximum rating will permanently damage the device.

Do not select the HN28F101 programmer setting for the H8/3048F-ONE (single power supply). If this setting is made by mistake, 12.0 V will be applied to the FWE pin, permanently damaging the device.

When using a PROM programmer to program the on-chip flash memory in the H8/3048F-ONE (single power supply), use a PROM programmer that supports Renesas Technology microcomputer device types with 128-kbyte on-chip flash memory.

18.1.2 Mode Pin Settings

The H8/3048F-ONE has 128 kbytes of on-chip flash memory. The flash memory is connected to the CPU by a 16-bit data bus. The CPU accesses both byte data and word data in two states, enabling rapid data transfer.

The mode pins (MD_2 to MD_0), FWE pin, and RXD1 pin can be set to enable or disable the on-chip ROM as indicated in table 18.1.

Table 18.1 Operating Mode and ROM

Mode	Pin Name					On-Chip ROM
	MD_2	MD_1	MD_0	FWE	RXD1	
Mode 1 (1-Mbyte expanded mode with on-chip ROM disabled)	0	0	1	0	0/1	Disabled (external address area)
Mode 2 (1-Mbyte expanded mode with on-chip ROM disabled)	0	1	0	0	0/1	
Mode 3 (16-Mbyte expanded mode with on-chip ROM disabled)	0	1	1	0	0/1	
Mode 4 (16-Mbyte expanded mode with on-chip ROM disabled)	1	0	0	0	0/1	
Mode 5 (1-Mbyte expanded mode with on-chip ROM enabled)	1	0	1	0	0/1	Enabled
Mode 6 (16-Mbyte expanded mode with on-chip ROM enabled)	1	1	0	0	0/1	
Mode 7 (single-chip mode)	1	1	1	0	0/1	

The H8/3048F-ONE can be set to PROM mode and programmed with a general-purpose PROM programmer.

18.2 Flash Memory Features

The H8/3048F-ONE has 128 kbytes of on-chip flash memory. The features of the flash memory are summarized below.

- Four flash memory operating modes
 - Program mode
 - Erase mode
 - Program-verify mode
 - Erase-verify mode
- Programming/erase methods

The flash memory is programmed 128 bytes at a time. Block erase (in single-block units) can be performed. To erase the entire flash memory, each block must be erased in turn. Block erasing can be performed as required on 1 kbyte, 28 kbytes, and 32 kbytes blocks.
- Programming/erase times

The flash memory programming time is 10 ms (typ.) for simultaneous 128-byte programming, equivalent approximately to 80 μ s (typ.) per byte, and the erase time is 100 ms (typ.).
- Reprogramming capability

The flash memory can be reprogrammed up to 100 times.
- On-board programming modes

There are two modes in which flash memory can be programmed/erased/verified on-board:

 - Boot mode
 - User program mode

In the boot mode, the transferred program from the host can be recognized.
- Automatic bit rate adjustment

With data transfer in boot mode, the LSI's bit rate can be automatically adjusted to match the transfer bit rate of the host.
- Flash memory emulation in RAM

Flash memory programming can be emulated in real time by overlapping a part of RAM onto flash memory.
- Protect modes

There are three protect modes, hardware, software, and error which allow protected status to be designated for flash memory program/erase/verify operations.
- PROM mode

Flash memory can be programmed/erased in PROM mode, using a PROM programmer, as well as in on-board programming mode.

18.2.1 Block Diagram

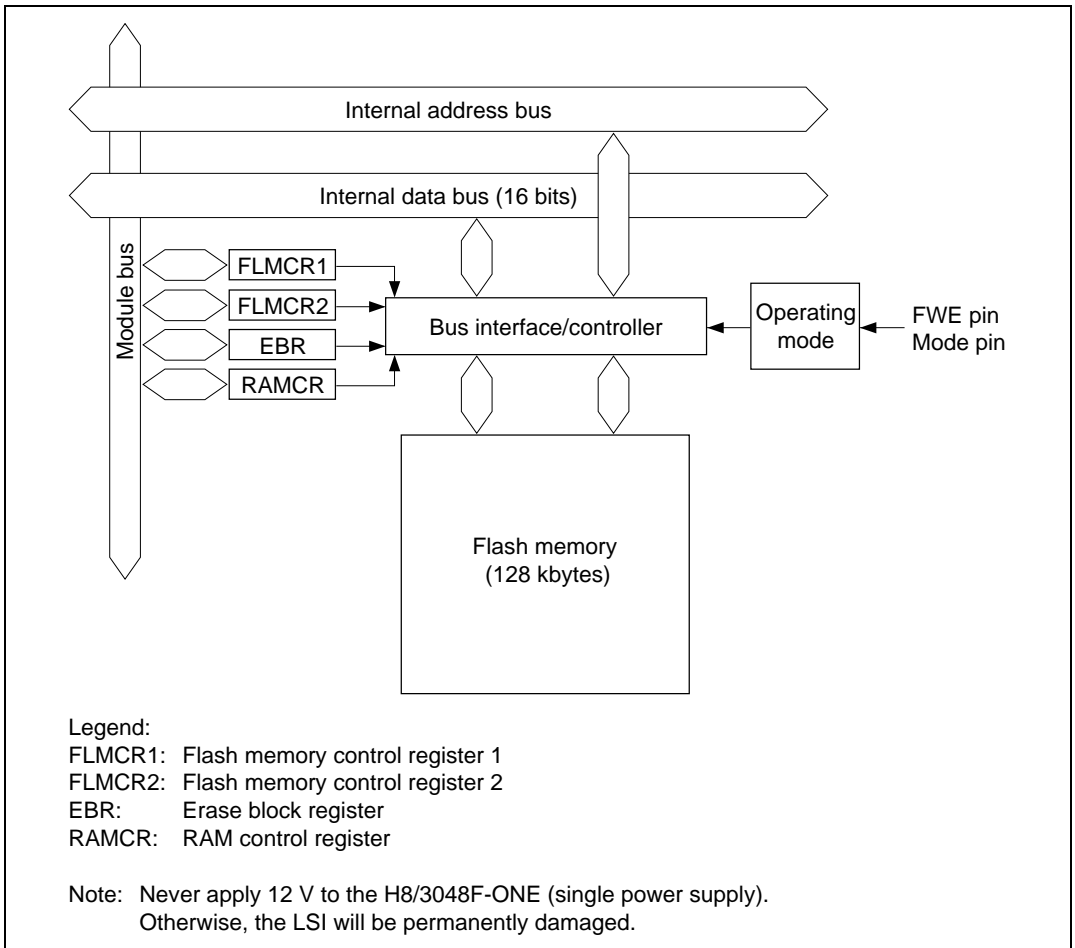
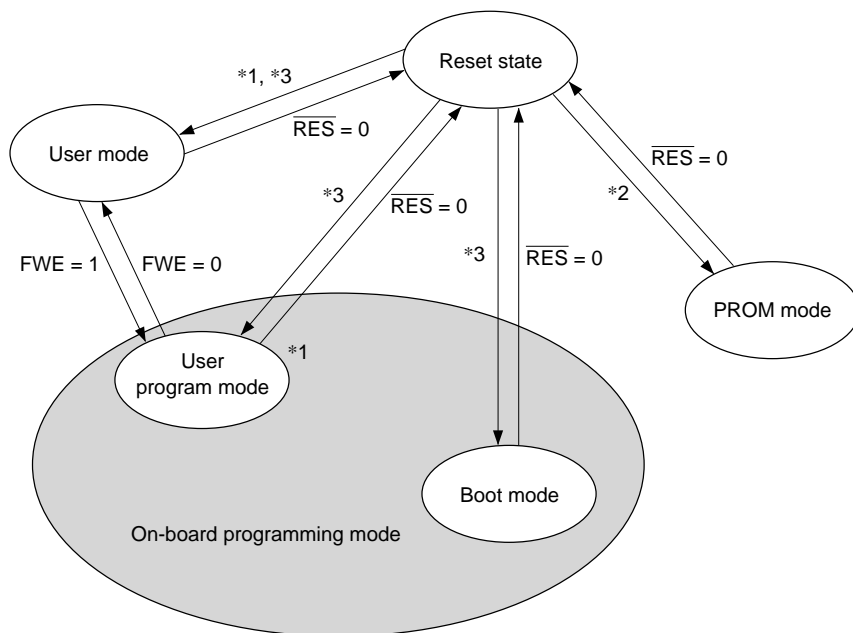

Figure 18.1 Block Diagram of Flash Memory

18.2.2 Mode Transitions

When the mode pins and the FWE pin are set in the reset state and a reset-start is executed, the microcomputer enters an operating mode as shown in figure 18.2. In user mode, flash memory can be read but not programmed or erased.

The boot, user program and PROM modes are provided as modes to write and erase the flash memory.



Notes: Only make a transition between user mode and user program mode when the CPU is not accessing the flash memory.

1. RAM emulation possible
2. The H8/3048F-ONE is placed in PROM mode by means of a dedicated PROM writer.
3. Mode settings are shown in the following table.
4. For pins RXD1 and TXD1, use on-board pull-up in boot mode.

Mode	Pins				
	FWE	MD ₂	MD ₁	MD ₀	RXD1
Mode 1	0	0	0	1	0, 1
Mode 2		0	1	0	0, 1
Mode 3		0	1	1	0, 1
Mode 4		1	0	0	0, 1
Mode 5		1	0	1	0, 1
Mode 6		1	1	0	0, 1
Mode 7		1	1	1	0, 1
Boot mode 5	1	0	0	1	1*4
Boot mode 6		0	1	0	1*4
Boot mode 7		0	1	1	1*4
Setting prohibited		1	0	0	1
User program mode 5	1	1	0	1	0, 1
User program mode 6		1	1	0	0, 1
User program mode 7		1	1	1	0, 1

Figure 18.2 Flash Memory State Transitions

State transitions between the normal user mode and on-board programming mode are performed by changing the FWE pin level from high to low or from low to high. To prevent misoperation (erroneous programming or erasing) in these cases, the bits in the flash memory control registers (FLMCR1 and FLMCR2) should be cleared to 0 before making such a transition. After the bits are cleared, a wait time is necessary. Normal operation is not guaranteed if this wait time is insufficient.

18.2.3 On-Board Programming Modes

Boot Mode

1. Initial state

The old program version or data remains written in the flash memory. The user should prepare the programming control program and new application program beforehand in the host.

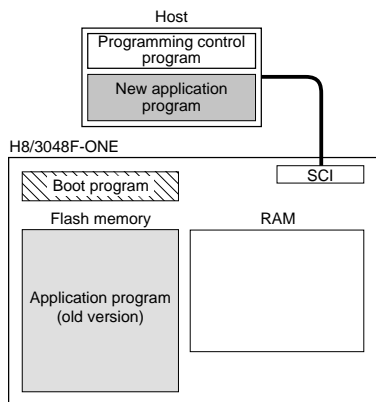

2. Programming control program transfer

When boot mode is entered, the boot program in the H8/3048F-ONE (originally incorporated in the chip) is started and the programming control program in the host is transferred to RAM via SCI communication. The boot program required for flash memory erasing is automatically transferred to the RAM boot program area.

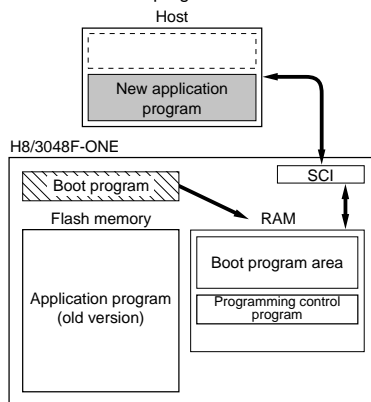

3. Flash memory initialization

The erase program in the boot program area (in RAM) is executed, and the flash memory is initialized (to H'FF). In boot mode, total flash memory erasure is performed, without regard to blocks.

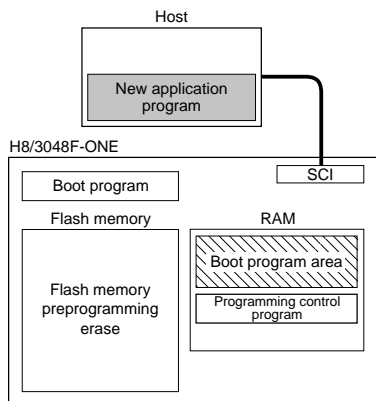

4. Writing new application program

The programming control program is recognized if it corresponds to the H8/3048F-ONE. The programming control program is then transferred from the host to RAM and is executed, and the new application program in the host is written into the flash memory.

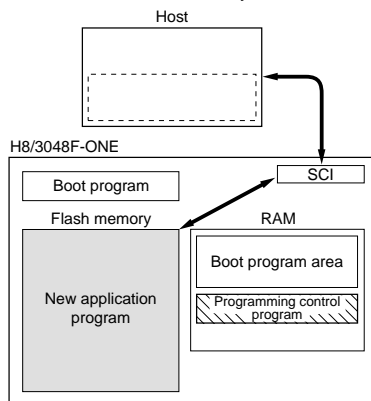

 Program execution state

Note: Never apply 12 V to the H8/3048F-ONE (single power supply). Otherwise, the LSI will be permanently damaged.

User Program Mode

1. Initial state

The FWE assessment program that confirms that user program mode has been entered, and the program that will transfer the programming/erase control program from flash memory to on-chip RAM should be written into the flash memory by the user beforehand. The programming/erase control program should be prepared in the host or in the flash memory.

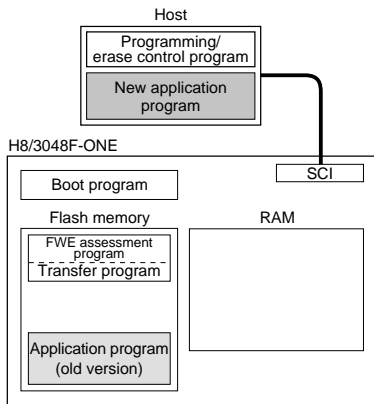

2. Programming/erase control program transfer

When user program mode is entered, user software confirms this fact, executes transfer program in the flash memory, and transfers the programming/erase control program to RAM.

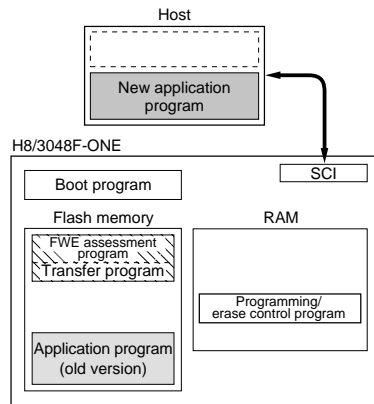

3. Flash memory initialization

The programming/erase program in RAM is executed, and the flash memory is initialized (to H'FF). Erasing can be performed in block units, but not in byte units.

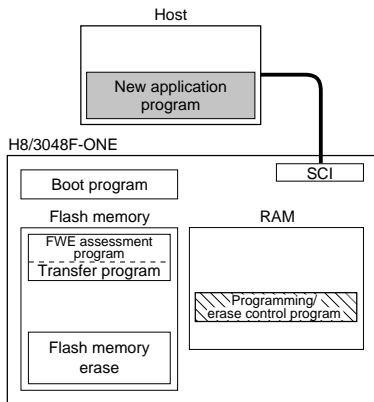

4. Writing new application program

Next, the new application program in the host is written into the erased flash memory blocks. Do not write to unerased blocks.

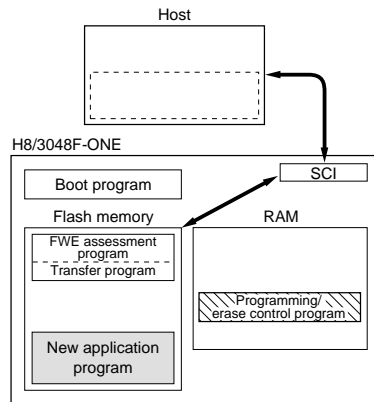

 Program execution state

Note: Never apply 12 V to the H8/3048F-ONE (single power supply).
Otherwise, the LSI will be permanently damaged.

18.2.4 Flash Memory Emulation in RAM

In the H8/3048F-ONE, flash memory programming can be emulated in real time by overlapping the flash memory with part of RAM (“overlap RAM”). When the emulation block set in RAMCR is accessed while the emulation function is being executed, data written in the overlap RAM is read. Emulation should be performed in user mode or user program mode.

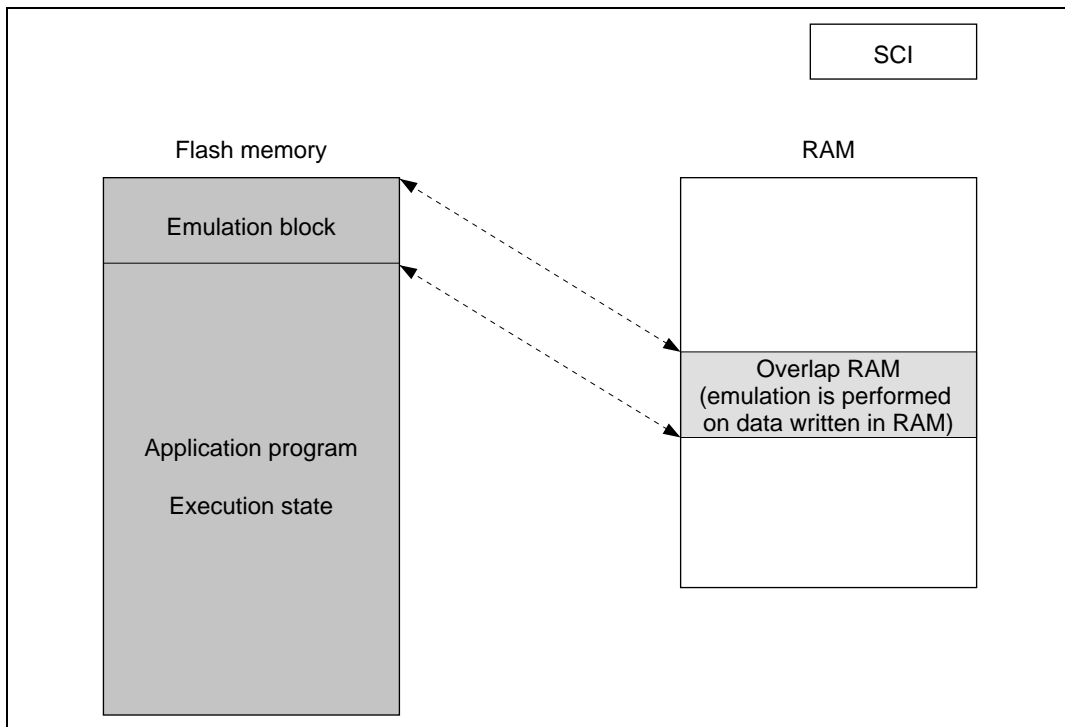

Figure 18.3 Reading Overlap RAM Data in User Mode or User Program Mode

When overlap RAM data is confirmed, clear the RAMS bit to release RAM overlap, and actually perform writes to the flash memory.

When the programming control program is transferred to RAM in on-board programming mode, ensure that the transfer destination and the overlap RAM do not overlap, as this will cause data in the overlap RAM to be rewritten.

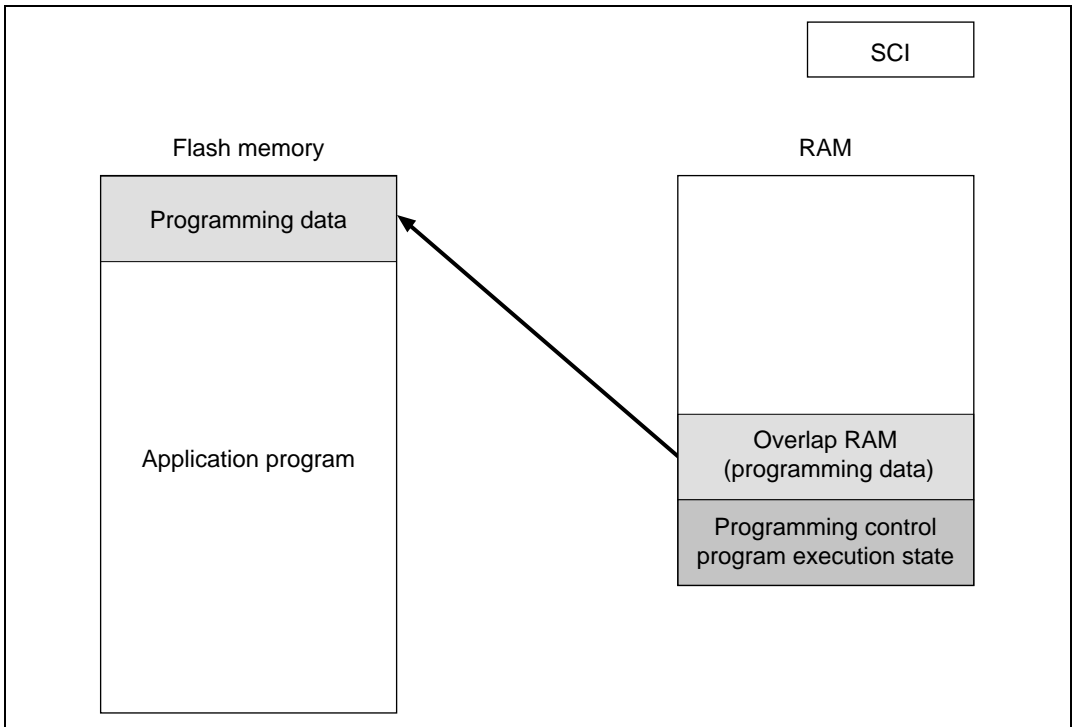

Figure 18.4 Writing Overlap RAM Data in User Program Mode

18.2.5 Differences between Boot Mode and User Program Mode

Item	Boot Mode	User Program Mode
Total erase	Yes	No
Block erase	No	Yes
Programming control program*	Boot program is initiated, and programming control program is transferred from host to on-chip RAM, and executed there.	Program that controls programming program in flash memory is executed. Program should be written beforehand in PROM mode and boot mode.

Note: * To be provided by the user, in accordance with the recommended algorithm.

18.2.6 Block Configuration

The flash memory in the H8/3048F-ONE is divided into three 32-kbyte blocks, one 28-kbyte block, and four 1-kbyte blocks and can be erased in these block units.

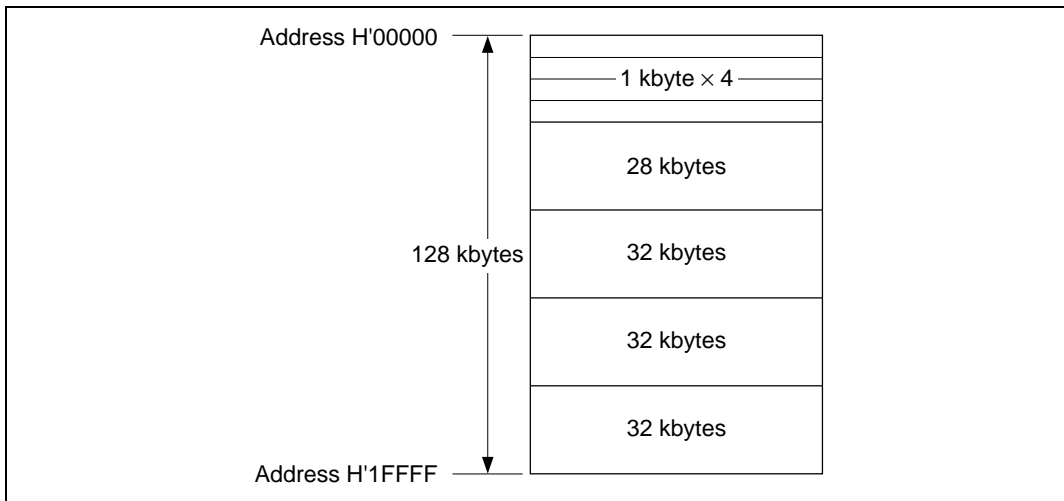

Figure 18.5 Erase Area Block Divisions

18.3 Flash Memory Pin Configuration

The flash memory is controlled by means of the pins shown in table 18.2.

Table 18.2 Pin Configuration

Pin Name	Abbreviation	I/O	Function
Reset	$\overline{\text{RES}}$	Input	Reset
Flash write enable	FWE ^{*1}	Input	Flash program/erase protection by hardware
Mode 2	MD2 ^{*1}	Input	Sets LSI operating mode
Mode 1	MD1	Input	Sets LSI operating mode
Mode 0	MD0	Input	Sets LSI operating mode
Transmit data	TxD1 ^{*2}	Output	Serial transmit data output
Receive data	RxD1 ^{*2}	Input	Serial receive data input

Notes: 1. Never apply 12 V to the H8/3048F-ONE (single power supply).
Otherwise, the LSI will be permanently damaged.

2. In boot mode, use on-board pull-up.

18.4 Flash Memory Register Configuration

The registers* used to control the on-chip flash memory when enabled are shown in table 18.3.

Note: * Access is prohibited to lower 16 address bits H'FF43 to H'FF46 and H'FF48 to H'FF4F. These bits are designed for the on-chip flash memory version and do not exist in the on-chip mask ROM version.

In the on-chip mask ROM version, these bits always read 1, and writing is disabled.

Table 18.3 Register Configuration

Register Name	Abbreviation	R/W	Initial Value	Address* ¹
Flash memory control register 1	FLMCR1* ⁵	R/W* ²	H'00* ³	H'FF40
Flash memory control register 2	FLMCR2* ⁵	R/W* ² * ⁶	H'00	H'FF41
Erase block register	EBR* ⁵	R/W* ²	H'00* ⁴	H'FF42
RAM control register	RAMCR* ⁵	R/W	H'F0	H'FF47

Notes: 1. Lower 16 bits of the address.

2. If the chip is in a mode in which the on-chip flash memory is disabled, a read will return H'00 and writes are invalid. Writes are also invalid when the FWE bit in FLMCR1 is not set to 1.

3. When a high level is input to the FWE pin, the initial value is H'80.

4. When a low level is input to the FWE pin, or if a high level is input and the SWE bit in FLMCR1 is 0, these registers are initialized to H'00.

5. FLMCR1, FLMCR2, EBR, and RAMCR are 8-bit registers.

Byte access must be used on these registers (do not use word or longword access).

6. Bits 6 to 0 are reserved bits but are readable/writable.

18.5 Flash Memory Register Descriptions

18.5.1 Flash Memory Control Register 1 (FLMCR1)

Bit	7	6	5	4	3	2	1	0
	FWE	SWE	ESU	PSU	EV	PV	E	P
Initial value	—*	0	0	0	0	0	0	0
Read/Write	R	R/W	R/W	R/W	R/W	R/W	R/W	R/W

Note: * Determined by the state of the FWE pin.

FLMCR1 is an 8-bit register used for flash memory operating mode control. Program-verify mode or erase-verify mode for addresses H'00000 to H'1FFFF is entered by setting SWE bit to 1 when FWE = 1, then setting the PV or EV bit. Program mode for addresses H'00000 to H'1FFFF is entered by setting SWE bit to 1 when FWE = 1, then setting the PSU bit, and finally setting the P bit. Erase mode for addresses H'00000 to H'1FFFF is entered by setting SWE bit to 1 when FWE = 1, then setting the ESU bit, and finally setting the E bit. FLMCR1 is initialized by a reset, and in hardware standby mode and software standby mode. Its initial value is H'80 when a high level is input to the FWE pin, and H'00 when a low level is input. When on-chip flash memory is disabled, a read will return H'00, and writes are invalid. Set 1 to bits 6 to 0 by each bit in this register.

Writes are enabled only in the following cases: Writes to bit SWE of FLMCR1 enabled when FWE = 1, to bits ESU, PSU, EV, and PV when FWE = 1 and SWE = 1, to bit E when FWE = 1, SWE = 1 and ESU = 1, and to bit P when FWE = 1, SWE = 1, and PSU = 1.

- Notes:
1. The programming and erase flowcharts must be followed when setting the bits in this register to prevent erroneous programming or erasing.
 2. Transitions are made to program mode, erase mode, program-verify mode, and erase-verify mode according to the settings in this register. When reading flash memory as normal on-chip ROM, bits 6 to 0 in this register must be cleared.

Bit 7—Flash Write Enable Bit (FWE): Sets hardware protection against flash memory programming/erasing.

Bit 7: FWE	Description
0	When a low level is input to the FWE pin (hardware-protected state)
1	When a high level is input to the FWE pin

Bit 6—Software Write Enable Bit (SWE): Enables or disables flash memory programming and erasing (applicable addresses: H'00000 to H'1FFFF). Set this bit when setting bits 5 to 0, bits 7 to 0 of EBR.

Bit 6: SWE	Description
0	Writes disabled (Initial value)
1	Writes enabled* [Setting condition] When FWE = 1

Note: * Do not execute a SLEEP instruction while the SWE bit is set to 1.

Bit 5—Erase Setup Bit (ESU): Prepares for a transition to erase mode (applicable addresses: H'00000 to H'1FFFF). Do not set the SWE, PSU, EV, PV, E, or P bit at the same time. Set this bit to 1 before setting bit E to 1 in FLMCR1.

Bit 5: ESU	Description	
0	Erase setup cleared	(Initial value)
1	Erase setup [Setting condition] When FWE = 1 and SWE = 1	

Bit 4—Program Setup Bit (PSU): Prepares for a transition to program mode (applicable addresses: H'00000 to H'1FFFF). Do not set the SWE, ESU, EV, PV, E, or P bit at the same time. Set this bit to 1 before setting bit P to 1 in FLMCR1.

Bit 4: PSU	Description	
0	Program setup cleared	(Initial value)
1	Program setup [Setting condition] When FWE = 1 and SWE = 1	

Bit 3—Erase-Verify Bit (EV): Selects erase-verify mode transition or clearing (applicable addresses: H'00000 to H'1FFFF). Do not set the SWE, ESU, PSU, PV, E, or P bit at the same time.

Bit 3: EV	Description	
0	Erase-verify mode cleared	(Initial value)
1	Transition to erase-verify mode [Setting condition] When FWE = 1 and SWE = 1	

Bit 2—Program-Verify Bit (PV): Selects program-verify mode transition or clearing (applicable addresses: H'00000 to H'1FFFF). Do not set the SWE, ESU, PSU, EV, E, or P bit at the same time.

Bit 2: PV	Description
0	Program-verify mode cleared (Initial value)
1	Transition to program-verify mode [Setting condition] When FWE = 1 and SWE = 1

Bit 1—Erase Bit (E): Selects erase mode transition or clearing (applicable addresses: H'00000 to H'1FFFF). Do not set the SWE, ESU, PSU, EV, PV, or P bit at the same time.

Bit 1: E	Description
0	Erase mode cleared (Initial value)
1	Transition to erase mode* [Setting condition] When FWE = 1, SWE = 1, and ESU = 1

Note: * Do not access flash memory while the E bit is set to 1.

Bit 0—Program Bit (P): Selects program mode transition or clearing (applicable addresses: H'00000 to H'1FFFF). Do not set the SWE, PSU, ESU, EV, PV, or E bit at the same time.

Bit 0: P	Description
0	Program mode cleared (Initial value)
1	Transition to program mode* [Setting condition] When FWE = 1, SWE = 1, and PSU = 1

Note: * Do not access flash memory while the P bit is set.

18.5.2 Flash Memory Control Register 2 (FLMCR2)

Bit	7	6	5	4	3	2	1	0
	FLER	—	—	—	—	—	—	—
Initial value	0	0	0	0	0	0	0	0
Read/Write	R	R/W	R/W	R/W	R/W	R/W	R/W	R/W

FLMCR2 is an 8-bit register used for flash memory operating mode control. FLMCR2 is initialized to H'00 by a reset, and in hardware standby mode and software standby mode. When the on-chip flash memory is disabled, a read will return H'00.

Note: Bits 6 to 0 are reserved bits but are readable/writable.

Bit 7—Flash Memory Error (FLER): Indicates that an error has occurred during an operation on flash memory (programming or erasing). When FLER is set to 1, flash memory goes to the error-protection state.

Bit 7:

FLER	Description
0	Flash memory is operating normally Flash memory program/erase protection (error protection) is disabled [Clearing condition] Reset ($\overline{\text{RES}}$ pin or WDT reset) or hardware standby mode (Initial value)
1	An error occurred during flash memory programming/erasing Flash memory program/erase protection (error protection) is enabled [Setting conditions] <ul style="list-style-type: none"> When flash memory is read during programming/erasing (including a vector read or instruction fetch, but excluding a read of the RAM area overlapping flash memory space) Immediately after the start of exception handling during programming/erasing (excluding reset, illegal instruction, trap instruction, and division-by-zero exception handling) When a SLEEP instruction (including software standby) is executed during programming/erasing When the bus is released during programming/erasing

Bits 6 to 0—Reserved: These bits are readable/writable.

18.5.3 Erase Block Register (EBR)

EBR is an 8-bit register that designates the flash memory block for erasure. EBR is initialized to H'00 by a reset, in hardware standby mode or software standby mode, when a high level is not input to the FWE pin, or when the SWE bit in FLMCR1 is 0 when a high level is applied to the FWE pin. When a bit is set in EBR, the corresponding block can be erased. Other blocks are erase-protected. The blocks are erased block by block. Therefore, set only one bit in EBR; do not set bits in EBR to erase two or more blocks at the same time.

Each bit in EBR cannot be set until the SWE bit in FLMCR1 is set. The flash memory block configuration is shown in table 18.4. To erase all the blocks, erase each block sequentially.

Bit		7	6	5	4	3	2	1	0
		EB7	EB6	EB5	EB4	EB3	EB2	EB1	EB0
Modes 1 to 4	Initial value	0	0	0	0	0	0	0	0
	Read/Write	R	R	R	R	R	R	R	R
Modes 5 to 7	Initial value	0	0	0	0	0	0	0	0
	Read/Write	R/W	R/W	R/W	R/W	R/W	R/W	R/W	R/W

Bits 7 to 0—Block 7 to Block 0 (EB7 to EB0): Setting one of these bits specifies the corresponding block (EB7 to EB0) for erasure.

Bits 7–0:

EB7–EB0	Description
0	Corresponding block (EB7 to EB0) not selected (Initial value)
1	Corresponding block (EB7 to EB0) selected

Note: When not performing an erase, clear EBR to H'00.

Table 18.4 Flash Memory Erase Blocks

Block (Size)	Address
EB0 (1 kbyte)	H'000000–H'0003FF
EB1 (1 kbyte)	H'000400–H'0007FF
EB2 (1 kbyte)	H'000800–H'000BFF
EB3 (1 kbyte)	H'000C00–H'000FFF
EB4 (28 kbytes)	H'001000–H'007FFF
EB5 (32 kbytes)	H'008000–H'00FFFF
EB6 (32 kbytes)	H'010000–H'017FFF
EB7 (32 kbytes)	H'018000–H'01FFFF

18.5.4 RAM Control Register (RAMCR)

Bit		7	6	5	4	3	2	1	0
		—	—	—	—	RAMS	RAM2	RAM1	—
Modes 1 to 4	Initial value	1	1	1	1	0	0	0	0
	Read/Write	—	—	—	—	R	R	R	—
Modes 5 to 7	Initial value	1	1	1	1	0	0	0	0
	Read/Write	—	—	—	—	R/W	R/W	R/W	R/W

Reserved bits
Reserved bit

RAM2, RAM1
 Used together with bit 3 to select a flash memory area

RAM select
 Used together with bits 2 and 1 to select a flash memory area

RAMCR selects the RAM area to be used when emulating real-time flash memory programming. RAMCR initialized to H'F0 by a reset and in hardware standby mode. It is not initialized in software standby mode. RAMCR settings should be made in user mode or user program mode.*

Note: * When performing flash memory emulation by RAM, the RAME bit in SYSCR must be set to 1.

RAM area settings are shown in table 18.5. To ensure correct operation of the emulation function, the ROM for which RAM emulation is performed should not be accessed immediately after this

register has been modified. Normal execution of an access immediately after register modification is not guaranteed.

Bits 7 to 4—Reserved: These bits always read 1. Writing is disabled.

Bit 3—RAM Select (RAMS): Specifies selection or non-selection of flash memory emulation in RAM. When RAMS = 1, all flash memory block are program/erase-protected.

Bit 3: RAMS	Description
0	Emulation not selected (Initial value) Program/erase-protection of all flash memory blocks is disabled
1	Emulation selected Program/erase-protection of all flash memory blocks is enabled

Bits 2 and 1—RAM2 and RAM1: These bits are used with bit 3 to reassign an area to RAM (see table 18.5).

Bit 0—Reserved: This bit is readable/writable.

Table 18.5 RAM Area Setting

RAM Area	Bit 3	Bit 2	Bit 1	RAM Emulation Status
	RAMS	RAM2	RAM1	
H'FFF000–H'FFF3FF	0	0/1	0/1	No emulation
H'000000–H'0003FF	1	0	0	Mapping RAM
H'000400–H'0007FF	1	0	1	
H'000800–H'000BFF	1	1	0	
H'000C00–H'000FFF	1	1	1	

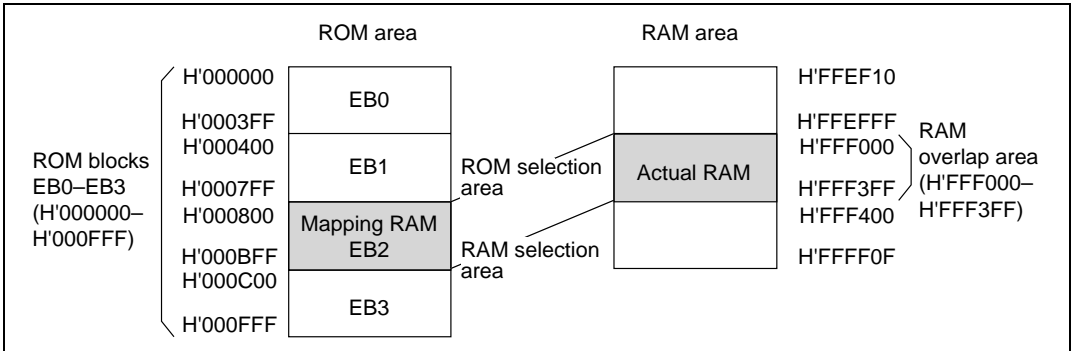

Figure 18.6 Example of ROM Area/RAM Area Overlap

18.6 Flash Memory On-Board Programming Modes

When pins are set to on-board programming mode and a reset-start is executed, a transition is made to the on-board programming state in which program/erase/verify operations can be performed on the on-chip flash memory. There are two on-board programming modes: boot mode and user program mode. The pin settings for transition to each of these modes are shown in table 18.6. For a diagram of the transitions to the various flash memory modes, see figure 18.2.

Table 18.6 Setting On-Board Programming Modes

Mode		FWE* ²	MD ₂ * ²	MD ₁	MD ₀	RxD ₁	Notes
Boot mode	Mode 5	1* ¹	0* ¹	0	1	1* ³	0: V _{IL}
	Mode 6		0* ¹	1	0	1* ³	1: V _{IH}
	Mode 7		0* ¹	1	1	1* ³	
User program mode	Mode 5		1* ¹	0	1	0/1	
	Mode 6		1* ¹	1	0	0/1	
	Mode 7		1* ¹	1	1	0/1	

- Notes: 1. (1) For the high-level application timing, see Notes on Use of Boot Mode.
 (2) In boot mode, the inverse of the MD₂ setting should be input.
 (3) In boot mode, the mode control register (MDCR) can be used to monitor the status of modes 5, 6, and 7, in the same way as in normal mode.
2. Never apply 12 V to the H8/3048F-ONE (single power supply). If do so, the LSI will be permanently damaged.
3. For pins RXD₁ and TXD₁, use on-board pull-up.

18.6.1 Boot Mode

When boot mode is used, the flash memory programming control program must be prepared in the host beforehand. The SCI channel to be used is set to asynchronous mode.

When a reset-start is executed after H8/3048F-ONE's pins have been set to boot mode, the boot program built into the LSI is started and the programming control program prepared in the host is serially transmitted to the LSI via the SCI. In the LSI, the programming control program received via the SCI is written into the programming control program area in on-chip RAM. After the transfer is completed, the programming control program is recognized (the ID code is checked) if it corresponds to the H8/3048F-ONE. When the ID code is matched, control branches to the start address of the programming control program area and the programming control program execution state is entered (flash memory programming is performed).

The transferred programming control program must therefore include coding that follows the programming algorithm given later.

The system configuration in boot mode is shown in figure 18.7, and the boot mode execution procedure in figure 18.8.

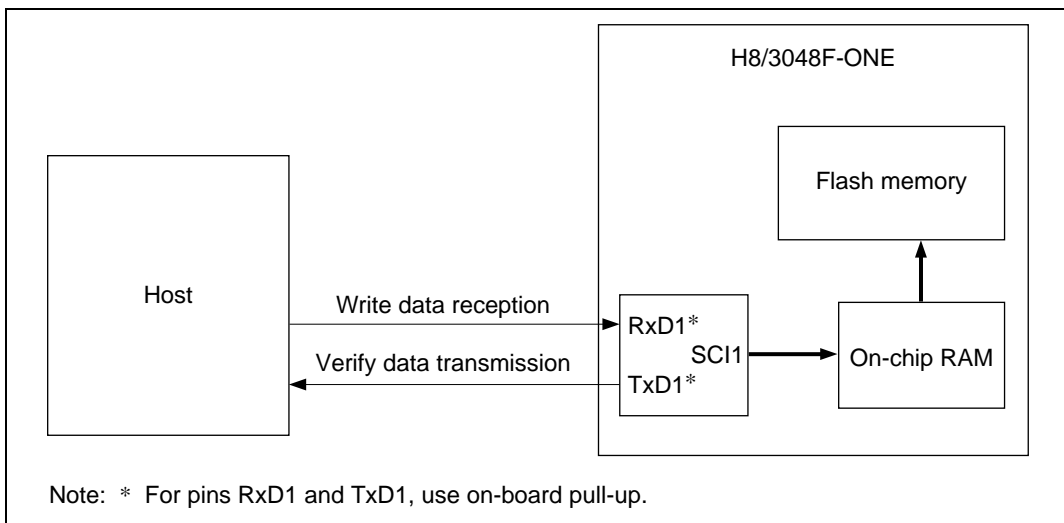

Figure 18.7 System Configuration in Boot Mode

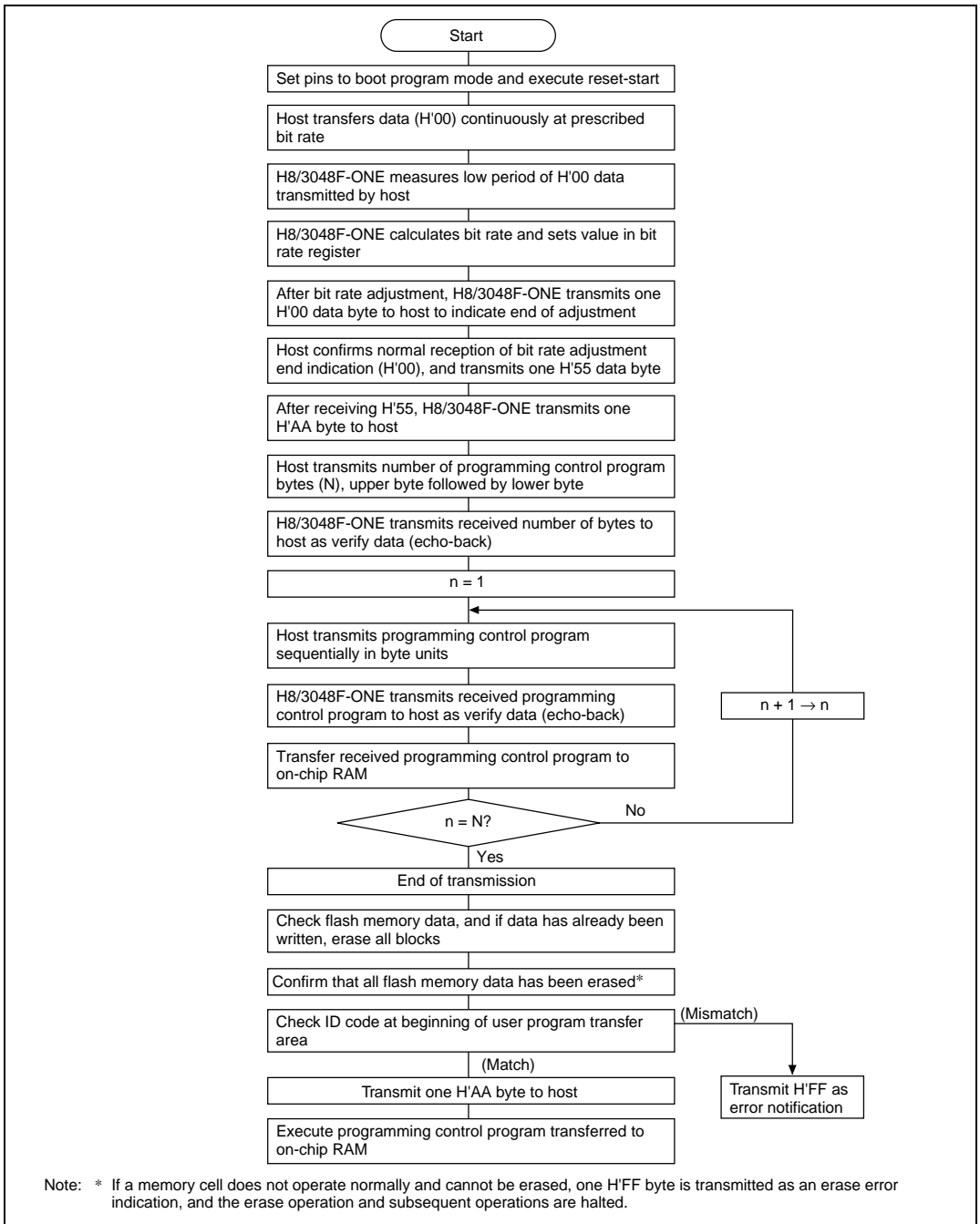
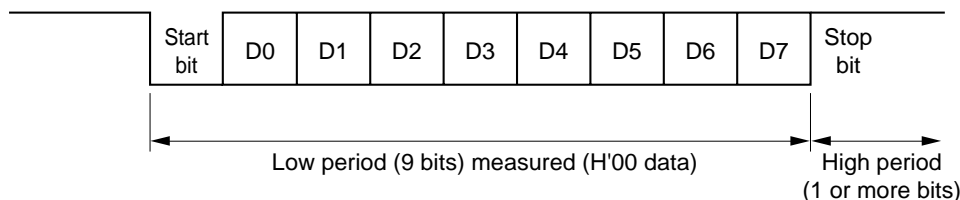

Figure 18.8 Boot Mode Execution Procedure

Automatic SCI Bit Rate Adjustment



When boot mode is initiated, H8/3048F-ONE measures the low period of the asynchronous SCI communication data (H'00) transmitted continuously from the host. The SCI transmit/receive format should be set as follows: 8-bit data, 1 stop bit, no parity. H8/3048F-ONE calculates the bit rate of the transmission from the host from the measured low period, and transmits one H'00 byte to the host to indicate the end of bit rate adjustment. The host should confirm that this adjustment end indication (H'00) has been received normally, and transmit one H'55 byte to H8/3048F-ONE. If reception cannot be performed normally, initiate boot mode again (reset), and repeat the above operations. Depending on the host's transmission bit rate and H8/3048F-ONE's system clock frequency, there will be a discrepancy between the bit rates of the host and H8/3048F-ONE. Set the host transfer bit rate at 4,800, 9,600 or 19,200 bps* to operate the SCI properly.

Table 18.7 shows host transfer bit rates and system clock frequencies for which automatic adjustment of H8/3048F-ONE bit rate is possible. The boot program should be executed within this system clock range.

Table 18.7 System Clock Frequencies for which Automatic Adjustment of H8/3048F-ONE Bit Rate is Possible

Host Bit Rate	System Clock Frequency for Which Automatic Adjustment of LSI Bit Rate is Possible (MHz)
4800 bps	4 to 25
9,600 bps	8 to 25
19,200 bps	16 to 25

Note: * Use a host bit rate setting of 4800, 9600, or 19200 bps only. No other setting should be used.

Although the H8/3048F-ONE may also perform automatic bit rate adjustment with bit rate and system clock combinations other than those shown in table 18.7, a degree of error will arise between the bit rates of the host and the H8/3048F-ONE, and subsequent transfer will not be performed normally. Therefore, only combinations of bit rate and system clock within the ranges shown in table 18.7 can be used for boot mode execution.

On-Chip RAM Area Divisions in Boot Mode

In boot mode, the RAM area is divided into an area used by the boot program and an area to which the programming control program is transferred via the SCI, as shown in figure 18.9. The boot program area cannot be used until the execution state in boot mode switches to the programming control program transferred from the host.

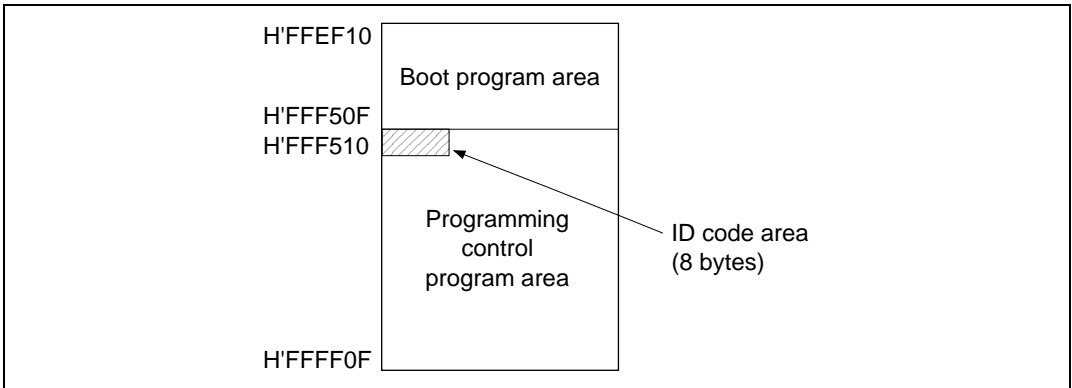
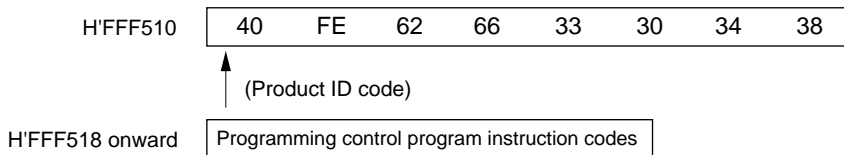

Figure 18.9 RAM Areas in Boot Mode

Note: The boot program area cannot be used until a transition is made to the execution state for the programming control program transferred to RAM. Note also that the boot program remains in this area of the on-chip RAM even after control branches to the programming control program.

In boot mode in the H8/3048F-ONE, the contents of the 8-byte ID code area shown below are checked to determine whether the program is a programming control program compatible with the H8/3048F-ONE.



If an original programming control program is used in boot mode, the 8-byte ID code shown above should be added at the beginning of the program.

Notes on Using the Boot Mode

1. When this LSI comes out of reset in boot mode, it measures the low period the input at the SCI's RXD₁ pin. The reset should end with RXD₁ high. After the reset ends, it takes about 100 states for this LSI to get ready to measure the low period of the RXD₁ input.
2. In boot mode, if any data has been written to the flash memory (if all data is not H'FF), all flash memory blocks are erased. Therefore, this mode should be used for initial on-board programming, or for forced recovery if the program to be activated in user program mode is accidentally erased and user program mode cannot be executed, for example.
3. Interrupts cannot be used during programming or erasing of flash memory.
4. The RXD₁ and TXD₁ pins should be pulled up on the board.
5. This LSI terminates transmit and receive operations by the on-chip SCI(channel 1) (by clearing the RE and TE bits in serial control register (SCR)) before branching to the transmit data output pin. However, the adjusted bit rate is held in the bit rate register (BRR). At this time, the TXD₁ is in the high level output state (P9DDR P9,DDR=1, P9DR P9,DR=1).

Before branching to the programming control program the value of the general registers in the CPU are also undefined. Therefore, the general registers must be initialized immediately after control branches to the programming control program. Since the stack pointer (SP) is implicitly used during subroutine call, etc., a stack area must be specified for use by the programming control program.

There are no other internal I/O registers in which the initial value is changed.

6. Transition to the boot mode executes a reset-start of this LSI after setting the MD₀ to MD₂, FWE, and RXD1 pins according to the mode setting conditions shown in table 18.6.

At this time, this LSI latches the status of the mode pin inside the microcomputer to maintain the boot mode status at the reset clear (startup from Low level to High level) timing^{*1}.

To clear boot mode, it is necessary to drive the FWE pin low during the reset, and then execute reset release^{*1}. The following points must be noted:

- Before making a transition from the boot mode to the regular mode, the microcomputer boot mode must be reset by reset input via the $\overline{\text{RES}}$ pin^{*1}. At this time, the $\overline{\text{RES}}$ pin must be hold at low level for at least 20 system clock^{*2}.
- Do not change the input levels at the mode pins (MD₂ to MD₀) or the FWE pin while in boot mode. When making a mode transition, first enter the reset state by inputting a low level to the $\overline{\text{RES}}$ pin. When a watchdog timer reset was generated in the boot mode, the microcomputer mode is not reset and the on-chip boot program is restarted regardless of the state of the mode pin.

- Do not input low level to the FWE pin while the boot program is executing and when programming/erasing flash memory*³.
7. If the mode pins (MD₂ to MD₀), FWE pin, and RXD1 pin input levels are changed (e.g., from low level to high level) during a reset (while a low level is being input to the $\overline{\text{RES}}$ pin), since the microcomputer's operating mode will change and the state of the address dual port and bus control output signals ($\overline{\text{CSn}}$, $\overline{\text{RD}}$, $\overline{\text{HWR}}$, $\overline{\text{LWR}}$) changes, use of these pins as output signals during reset must be disabled outside the microcomputer.

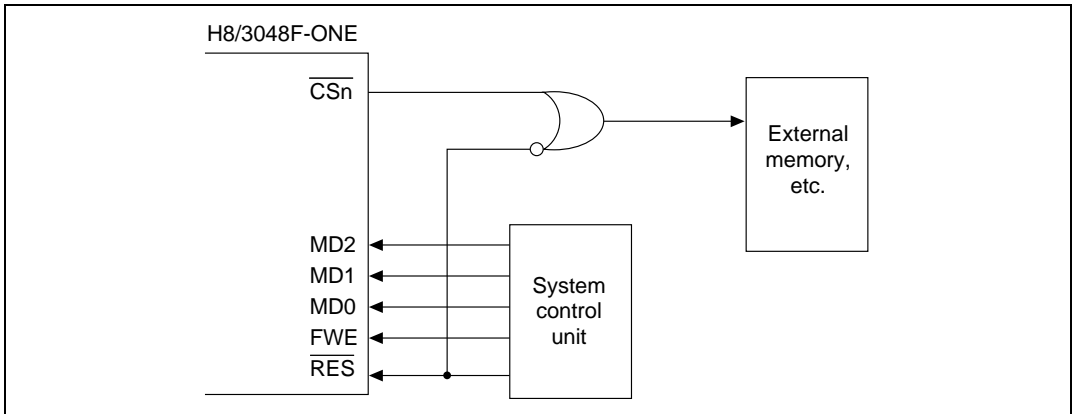

Figure 18.10 Recommended System Block Diagram

- Notes:
1. The mode pin, FWE pin, and RXD1 pin input must satisfy the mode programming setup time (t_{MDS}) relative to the reset clear timing.
 2. See section 4.2.2, Reset Sequence and 18.11, Notes on Flash Memory Programming/Erasing. The H8/3048F-ONE requires a minimum of 20 system clocks.
 3. For notes on FWE pin High/Low, see section 18.11, Notes on Flash Memory Programming/Erasing.

18.6.2 User Program Mode

When set to the user program mode, user's programming/erasing control program can erase and program the flash memory. Therefore, on-chip flash memory on-board programming can be performed by providing a means of controlling FWE and supplying the write data on the board and providing a programming/erasing program in a part of the program area.

To select this mode, activate H8/3048F-ONE to on-chip flash memory enable modes 5, 6, and 7 and apply a high level to the FWE pin. In this state, the peripheral functions, other than flash memory, are performed the same as in modes 5, 6, and 7.

Since the flash memory cannot be read while it is being programmed/erased, place a programming program on external memory, or transfer the programming program to RAM area, and execute it in the RAM.

Figure 18.11 shows the procedure for executing when transferred to on-chip RAM. During reset start, starting from the user program mode is possible.

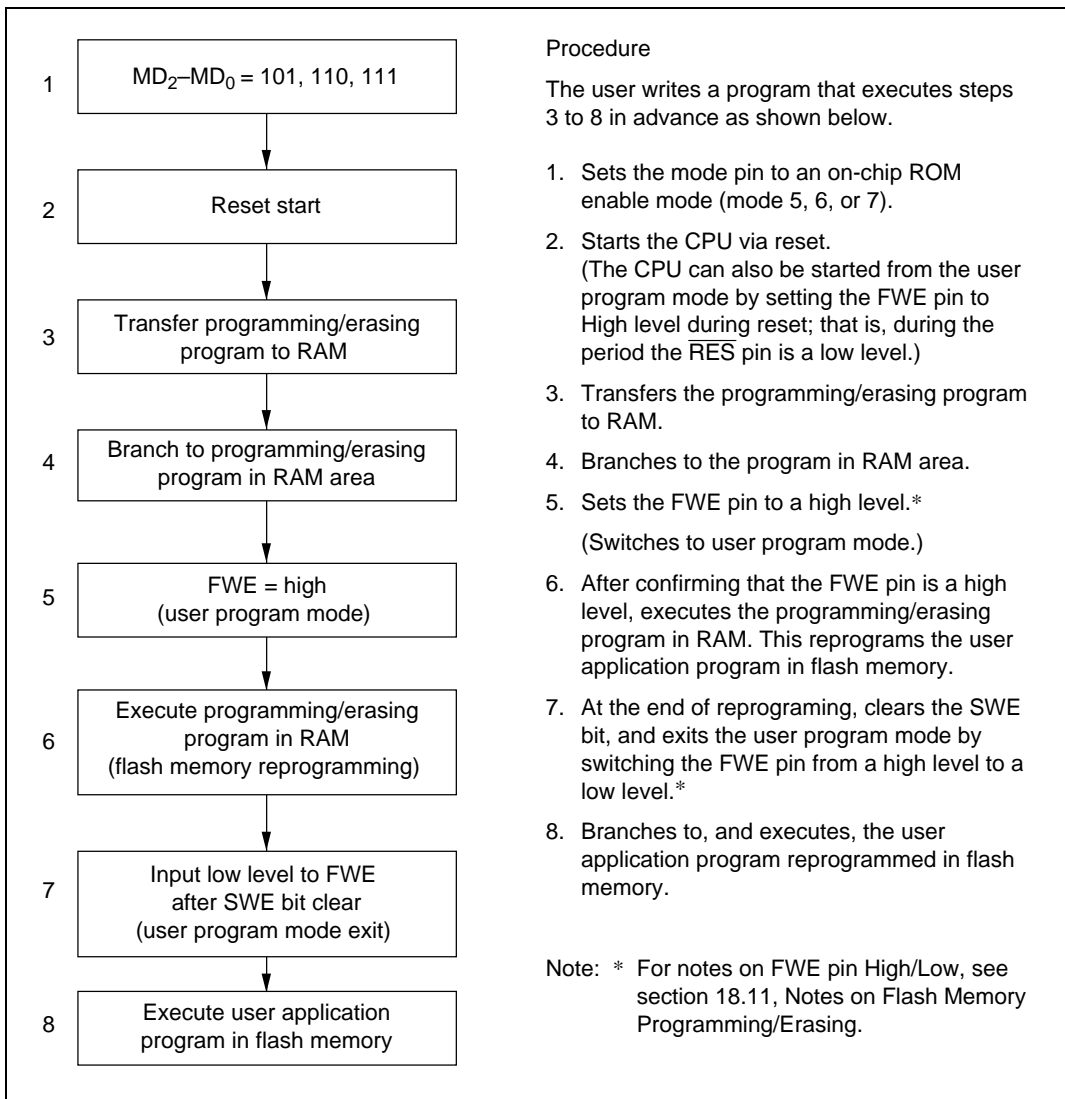

Figure 18.11 User Program Mode Execution Procedure (Example)

Notes: 1. Normally do not apply a high level to the FWE pin. Apply a high level to the FWE pin only when programming/erasing flash memory (including flash memory emulation by RAM).

Also, while a high level is input to the FWE pin, the watchdog timer should be activated to prevent overprogramming or overerasing due to program runaway, etc.

2. When the flash memory is read normally in the user program mode, the programming/erasing program must not be executed. Bits 6 to 0 in FLMCR1 must be cleared to 0.

18.7 Programming/Erasing Flash Memory

A software method, using the CPU, is employed to program and erase flash memory in the on-board programming modes. There are four flash memory operating modes: program mode, erase mode, program-verify mode, and erase-verify mode. Transitions to these modes are made by setting the PSU, ESU, P, E, PV, and EV bits in FLMCR1 for addresses H'000000 to H'01FFFF.

The flash memory cannot be read while it is being written or erased. Install the program to control flash memory programming and erasing (programming control program) in the on-chip RAM or in external memory, and execute the program from there.

See section 18.11, Notes on Flash Memory Programming/Erasing, for points to be noted when programming or erasing the flash memory. In the following operation descriptions, wait times after setting or clearing individual bits in FLMCR1 are given as parameters; for details of the wait times, see section 21.1.6, Flash Memory Characteristics.

- Notes: 1. Operation is not guaranteed if bits SWE, ESU, PSU, EV, PV, E, and P of FLMCR1 are set/reset by a program in flash memory in the corresponding address areas.
2. When programming or erasing, set FWE to 1 (programming/erasing will not be executed if FWE = 0).
 3. Programming should be performed in the erased state. Do not perform additional programming on previously programmed addresses.

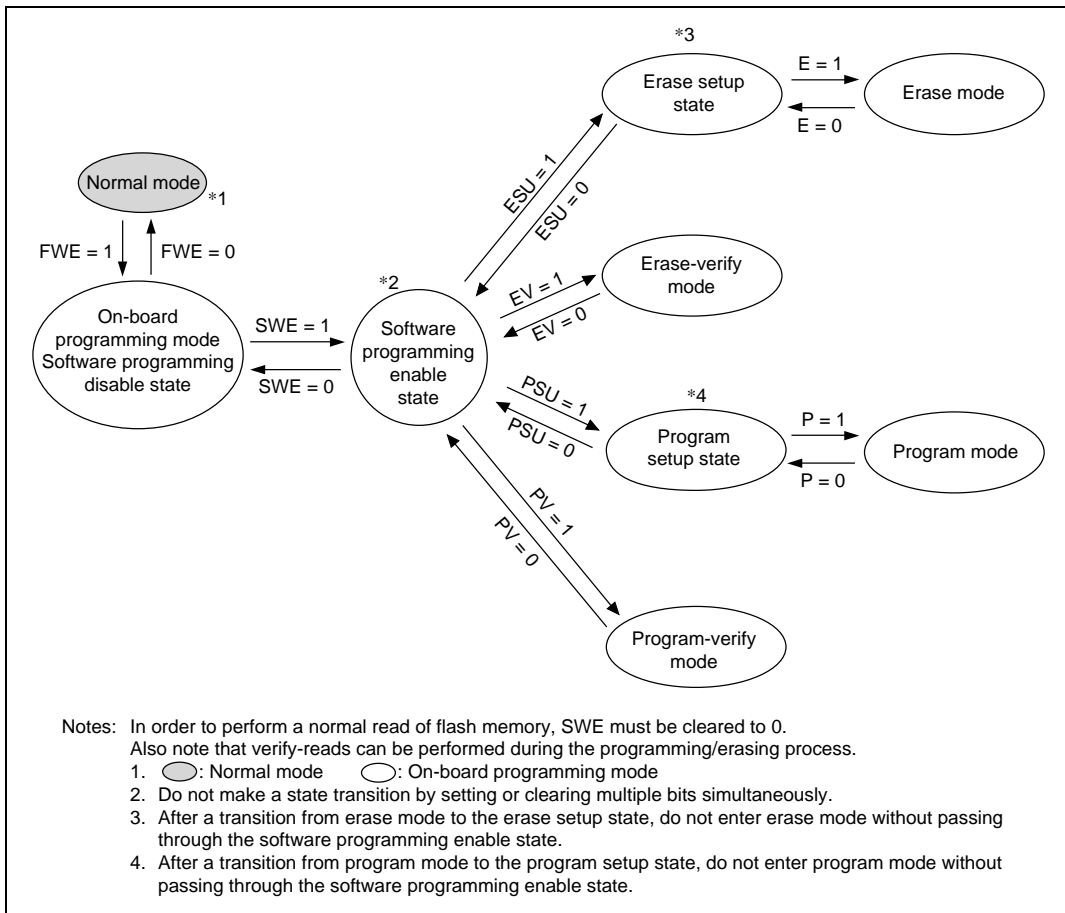

Figure 18.12 State Transitions Caused by FLMCR1 Bit Settings

18.7.1 Program Mode

To write data or programs to flash memory, the program/program-verify flowchart shown in figure 18.13 should be followed. Performing program operations according to this flowchart will enable data or programs to be written to flash memory without subjecting the device to voltage stress or sacrificing program data reliability. Programming should be carried out 128 bytes at a time.

The wait times after bits are set or cleared in the flash memory control register 1 (FLMCR1) and the maximum number of programming operations (N) are shown in table 21.11 in section 21.1.6, Flash Memory Characteristics.

Following the elapse of (t_{aswe}) μs or more after the SWE bit is set to 1 in FLMCR1, 128-byte data is written consecutively to the write addresses. The lower 8 bits of the first address written to must be H'00 and H'80, 128 consecutive byte data transfers are performed. The program address and program data are latched in the flash memory. A 128-byte data transfer must be performed even if writing fewer than 128 bytes; in this case, H'FF data must be written to the extra addresses.

Next, the watchdog timer (WDT) is set to prevent overprogramming due to program runaway, etc. Set a value greater than ($t_{\text{spsu}} + t_{\text{sp}} + t_{\text{cp}} + t_{\text{cpsu}}$) μs as the WDT overflow period. Preparation for entering program mode (program setup) is performed next by setting the PSU bit in FLMCR1. The operating mode is then switched to program mode by setting the P bit in FLMCR1 after the elapse of at least (t_{spsu}) μs . The time during which the P bit is set is the flash memory programming time. Make a program setting so that the time for one programming operation is within the range of (t_{sp}) μs .

The wait time after P bit setting must be changed according to the number of reprogramming loops. For details, see Notes on Program/Program-Verify Procedure.

18.7.2 Program-Verify Mode

In program-verify mode, the data written in program mode is read to check whether it has been correctly written in the flash memory.

After the elapse of the given programming time, clear the P bit in FLMCR1, then wait for at least (t_{cp}) μ s before clearing the PSU bit to exit program mode. After exiting program mode, the watchdog timer setting is also cleared. The operating mode is then switched to program-verify mode by setting the PV bit in FLMCR1. Before reading in program-verify mode, a dummy write of H'FF data should be made to the addresses to be read. The dummy write should be executed after the elapse of (t_{spv}) μ s or more. When the flash memory is read in this state (verify data is read in 16-bit units), the data at the latched address is read. Wait at least (t_{spvr}) μ s after the dummy write before performing this read operation. Next, the originally written data is compared with the verify data, and reprogram data is computed (see figure 18.13) and transferred to RAM. After verification of 128 bytes of data has been completed, exit program-verify mode, wait for at least (t_{cpv}) μ s, then determine whether 128-byte programming has finished. If reprogramming is necessary, set program mode again, and repeat the program/program-verify sequence as before. The maximum value for repetition of the program/program-verify sequence is indicated by the maximum programming count (N). Leave a wait time of at least (t_{cswe}) μ s after clearing SWE.

Notes on Program/Program-Verify Procedure

1. The program/program-verify procedure for the H8/3048F-ONE is a 128-byte-unit programming algorithm.
In order to perform 128-byte-unit programming, the lower 8 bits of the write start address must be H'00 or H'80.
2. When performing continuous writing of 128-byte data to flash memory, byte-unit transfer should be used.
128-byte data transfer is necessary even when writing fewer than 128 bytes of data. H'FF data must be written to the extra addresses.
3. Verify data is read in word units.
4. The write pulse is applied and a flash memory write executed while the P bit in FLMCR1 is set. In the H8/3048F-ONE, write pulses should be applied as follows in the program/program-verify procedure to prevent voltage stress on the device and loss of write data reliability.
 - a. After write pulse application, perform a verify-read in program-verify mode and apply a write pulse again for any bits read as 1 (reprogramming processing). When all the 0-write bits in the 128-byte write data are read as 0 in the verify-read operation, the program/program-verify procedure is completed. In the H8/3048F-ONE, the number of

loops in reprogramming processing is guaranteed not to exceed the maximum value of the maximum programming count (N).

- b. After write pulse application, a verify-read is performed in program-verify mode, and programming is judged to have been completed for bits read as 0. The following processing is necessary for programmed bits.

When programming is completed at an early stage in the program/program-verify procedure:

If programming is completed in the 1st to 6th reprogramming processing loop, additional programming should be performed on the relevant bits. Additional programming should only be performed on bits which first return 0 in a verify-read in certain reprogramming processing.

When programming is completed at a late stage in the program/program-verify procedure:

If programming is completed in the 7th or later reprogramming processing loop, additional programming is not necessary for the relevant bits.

- c. If programming of other bits is incomplete in the 128 bytes, reprogramming process should be executed. If a bit for which programming has been judged to be completed is read as 1 in a subsequent verify-read, a write pulse should again be applied to that bit.

5. **The period for which the P bit in FLMCR1 is set (the write pulse width) should be changed according to the degree of progress through the program/program-verify procedure.** For detailed wait time specifications, see section 21.1.6, Flash Memory Characteristics.

Table 18.8 Wait Time after P Bit Setting

Item	Symbol	Conditions	Symbol
Wait time after P bit setting	t_{sp}	When reprogramming loop count (n) is 1 to 6	$t_{sp}30$
		When reprogramming loop count (n) is 7 or more	$t_{sp}200$
		In case of additional programming processing*	$t_{sp}10$

Note: * Additional programming processing is necessary only when the reprogramming loop count (n) is 1 to 6.

6. The program/program-verify flowchart for the H8/3048F-ONE is shown in figure 18.13. To cover the points noted above, bits on which reprogramming processing is to be executed, and bits on which additional programming is to be executed, must be determined as shown below.

Since reprogram data and additional-programming data vary according to the progress of the programming procedure, it is recommended that the following data storage areas (128 bytes each) be provided in RAM.

Table 18.9 Reprogram Data Computation Table

(D)	Result of Verify-Read after Write Pulse Application (V)	(X) Result of Operation	Comments
0	0	1	Programming completed: reprogramming processing not to be executed
0	1	0	Programming incomplete: reprogramming processing to be executed
1	0	1	—
1	1	1	Still in erased state: no action

Legend:

Source data of bits on which programming is executed: (D)

Data of bits on which reprogramming is executed: (X)

Table 18.10 Additional-Programming Data Computation Table

X	Result of Verify-Read after Write Pulse Application (V)	(Y) Result of Operation	Comments
0	0	0	Programming by write pulse application judged to be completed: additional programming processing to be executed
0	1	1	Programming by write pulse application incomplete: additional programming processing not to be executed
1	0	1	Programming already completed: additional programming processing not to be executed
1	1	1	Still in erased state: no action

Legend:

Data of bits on which additional programming is executed: (Y)

Data of bits on which reprogramming is executed in a certain reprogramming loop: (X')

- It is necessary to execute additional programming processing during the course of the H8/3048F-ONE program/program-verify procedure. However, once 128-byte-unit programming is finished, additional programming should not be carried out on the same address area. When executing reprogramming, an erase must be executed first. Note that normal operation of reads, etc., is not guaranteed if additional programming is performed on addresses for which a program/program-verify operation has finished.

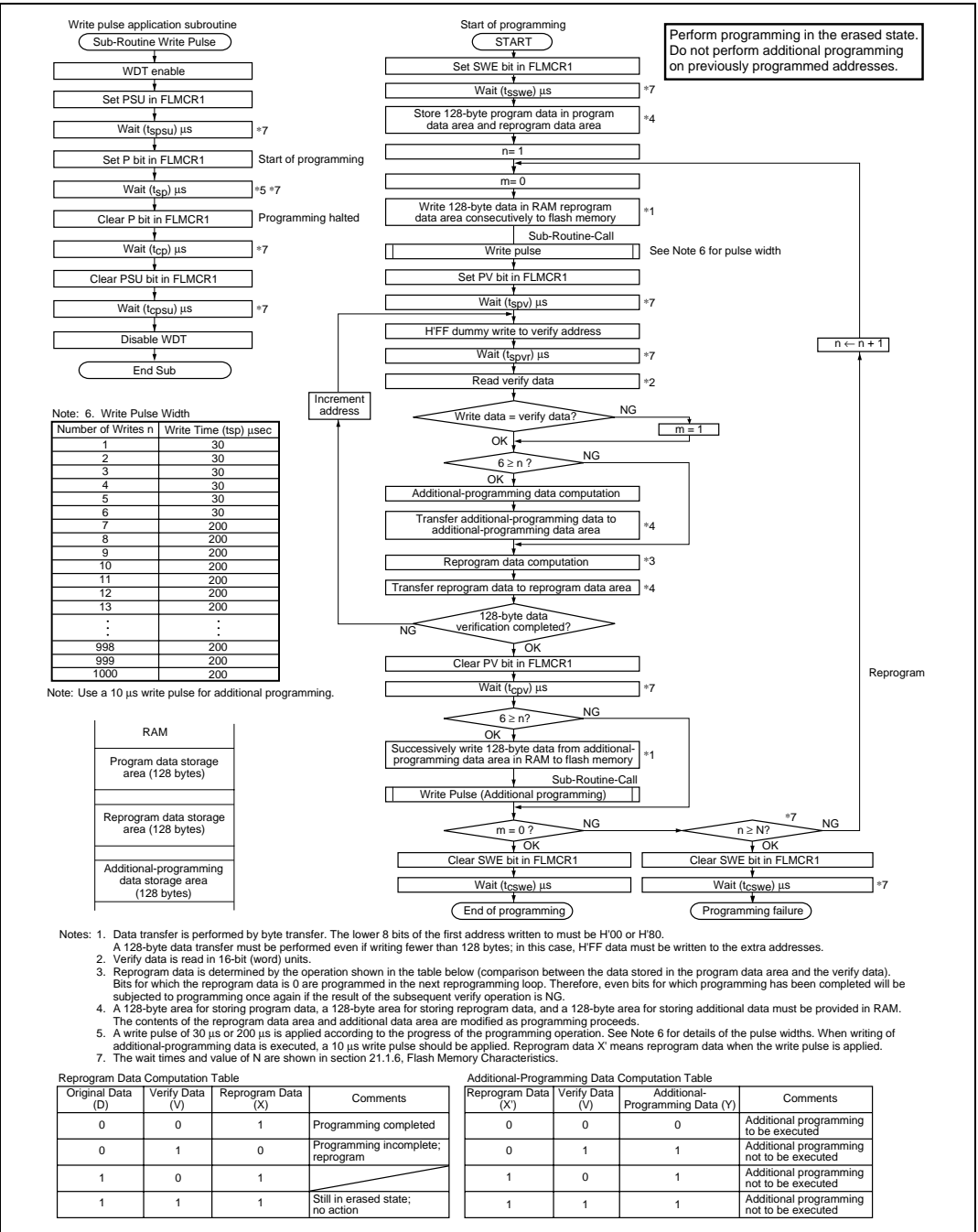

Figure 18.13 Program/Program-Verify Flowchart (128-Byte Programming)

18.7.3 Erase Mode

To erase an individual flash memory block, follow the flowchart for erasing one block (single-block erase) shown in figure 18.14.

The wait times after bits are set or cleared in the flash memory control register 1 (FLMCR1) and the maximum number of erase operations (N) are shown in table 21.11 in section 21.1.6, Flash Memory Characteristics.

To erase flash memory contents, make a 1-bit setting for the flash memory area to be erased in erase block register (EBR1) at least (t_{sswe}) μ s after setting the SWE bit to 1 in FLMCR1. Next, the watchdog timer (WDT) is set to prevent overerasing due to program runaway, etc. Set a value greater than (t_{se}) ms + ($t_{sesu} + t_{ce} + t_{cesu}$) μ s as the WDT overflow period. Preparation for entering erase mode (erase setup) is performed next by setting the ESU bit in FLMCR1. The operating mode is then switched to erase mode by setting the E bit in FLMCR1 after the elapse of at least (t_{sesu}) μ s. The time during which the E bit is set is the flash memory erase time. Ensure that the erase time does not exceed (t_{se}) ms.

Note: With flash memory erasing, preprogramming (setting all memory data in the memory to be erased to all 0) is not necessary before starting the erase procedure.

18.7.4 Erase-Verify Mode

In erase-verify mode, data is read after memory has been erased to check whether it has been correctly erased.

After the elapse of the fixed erase time, clear the E bit in FLMCR1, then wait for at least (t_{ce}) μ s before clearing the ESU bit to exit erase mode. After exiting erase mode, the watchdog timer setting is also cleared. The operating mode is then switched to erase-verify mode by setting the EV bit in FLMCR1. Before reading in erase-verify mode, a dummy write of H'FF data should be made to the addresses to be read. The dummy write should be executed after the elapse of (t_{sevr}) μ s or more. When the flash memory is read in this state (verify data is read in 16-bit units), the data at the latched address is read. Wait at least (t_{sevr}) μ s after the dummy write before performing this read operation. If the read data has been erased (all 1), a dummy write is performed to the next address, and erase-verify is performed. If the read data is unerased, set erase mode again, and repeat the erase/erase-verify sequence as before. The maximum value for repetition of the erase/erase-verify sequence is indicated by the maximum erase count (N). When verification is completed, exit erase-verify mode, and wait for at least (t_{cev}) μ s. If erasure has been completed on all the erase blocks, clear bit SWE1 in FLMCR1, and leave a wait time of at least (t_{cswe}) μ s.

If erasing multiple blocks, set a single bit in EBR for the next block to be erased, and repeat the erase/erase-verify sequence as before.

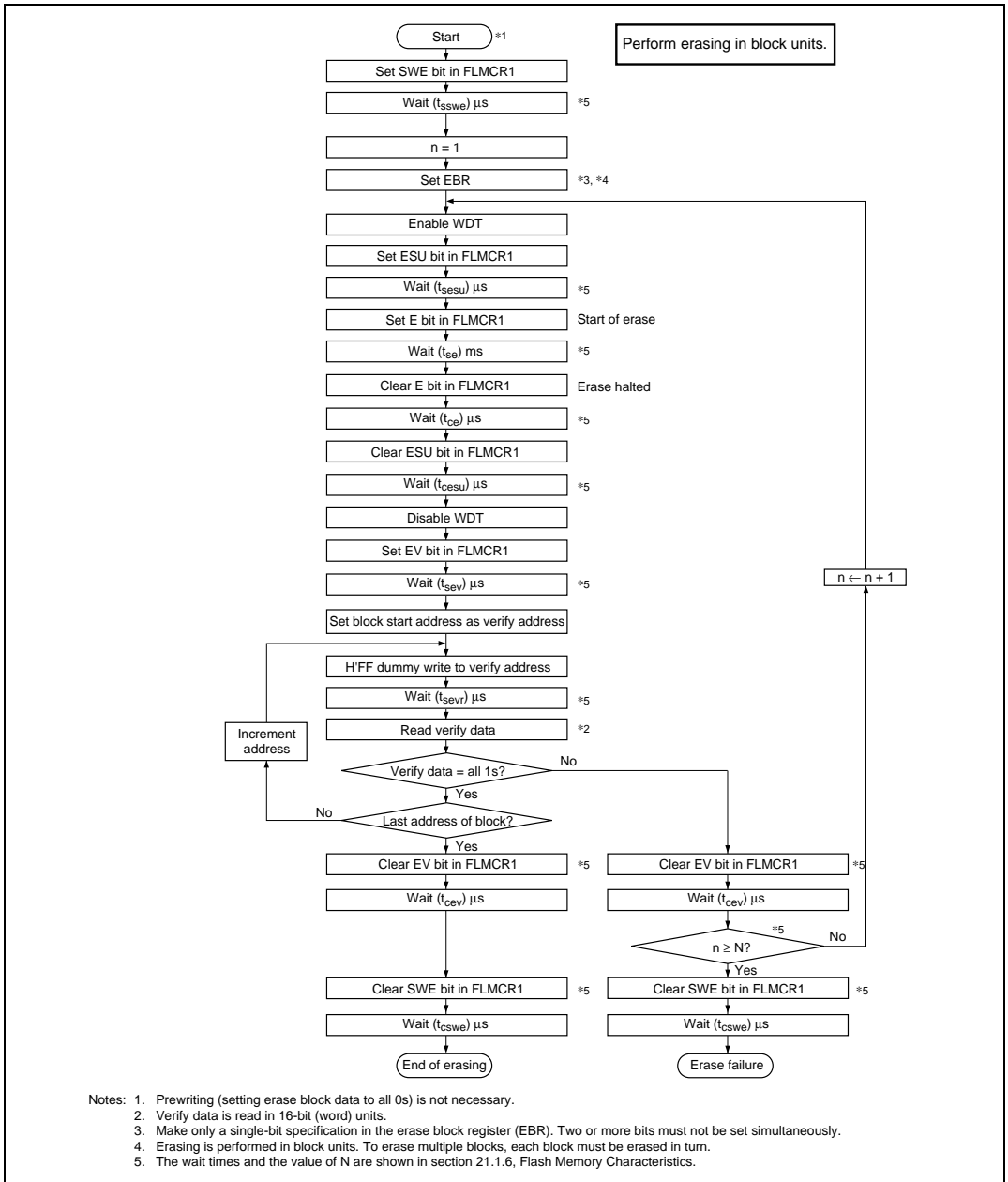

Figure 18.14 Erase/Erase-Verify Flowchart (Single-Block Erasing)

18.8 Flash Memory Protection

There are three kinds of flash memory program/erase protection: hardware protection, software protection, and error protection.

18.8.1 Hardware Protection

Hardware protection refers to a state in which programming/erasing of flash memory is forcibly disabled or aborted. Hardware protection is reset by settings in flash memory control register 1 (FLMCR1), and erase block register (EBR). In the error-protected state, the FLMCR1, FLMCR2, and EBR settings are retained; the P and E bits can be set, but a transition is not made to program mode or erase mode. (See table 18.11.)

Table 18.11 Hardware Protection

Item	Description	Functions		
		Program	Erase	Verify
FWE pin protection	<ul style="list-style-type: none"> When a low level is input to the FWE pin, FLMCR1, and EBR are initialized, and the program/erase-protected state is entered. 	No ^{*1}	No ^{*3}	No
Reset/standby protection	<ul style="list-style-type: none"> In a reset (including a WDT overflow reset) and in standby mode, FLMCR1, FLMCR2, and EBR are initialized, and the program/erase-protected state is entered. In a reset via the $\overline{\text{RES}}$ pin, the reset state is not entered unless the $\overline{\text{RES}}$ pin is held low until oscillation stabilizes after powering on. In the case of a reset during operation, hold the $\overline{\text{RES}}$ pin low for the $\overline{\text{RES}}$ pulse width specified in the AC Characteristics section^{*4}. 	No	No ^{*3}	No
Error protection	<ul style="list-style-type: none"> When a microcomputer operation error (error generation (FLER = 1)) was detected while flash memory was being programmed/erased, error protection is enabled. At this time, the FLMCR1 and EBR settings are held, but programming/erasing is aborted at the time the error was generated. Error protection is released only by a reset via the $\overline{\text{RES}}$ pin or a WDT reset, or in the hardware standby mode. 	No	No ^{*3}	Yes ^{*2}

- Notes:
1. Excluding a RAM area overlapping flash memory.
 2. It is possible to perform a program-verify operation on the 128 bytes being programmed, or an erase-verify operation on the block being erased.
 3. All blocks are unerasable and block-by-block specification is not possible.
 4. See section 4.2.2, Reset Sequence, and section 18.11, Notes on Flash Memory Programming/Erasing. The H8/3048F-ONE requires at least 20 system clocks for a reset period during operation.

18.8.2 Software Protection

Software protection can be implemented by setting, erase block register (EBR) and the RAMS bit in the RAM control register (RAMCR). When software protection is in effect, setting the P or E bit in flash memory control register 1 (FLMCR1) does not cause a transition to program mode or erase mode. (See table 18.12.)

Table 18.12 Software Protection

Item	Description	Functions		
		Program	Erase	Verify
Block specification protection	<ul style="list-style-type: none"> Erase protection can be set for individual blocks by settings in erase block register (EBR)^{*2}. However, programming protection is disabled. Setting EBR to H'00 places all blocks in the erase-protected state. 	—	No	Yes
Emulation protection	<ul style="list-style-type: none"> Setting the RAMS bit to 1 in the RAM control register (RAMCR) places all blocks in the program/erase-protected state. 	No ^{*1}	No ^{*3}	Yes

- Notes: 1. A RAM area overlapping flash memory can be written to.
 2. When not erasing, clear all EBR bits to 0.
 3. All blocks are unerasable and block-by-block specification is not possible.

18.8.3 Error Protection

In error protection, an error is detected when H8/3048F-ONE runaway occurs during flash memory programming/erasing^{*1}, or operation is not performed in accordance with the program/erase algorithm, and the program/erase operation is aborted. Aborting the program/erase operation prevents damage to the flash memory due to overprogramming or overerasing.

If the H8/3048F-ONE malfunctions during flash memory programming/erasing, the FLER bit is set to 1 in FLMCR2 and the error protection state is entered. The FLMCR1, FLMCR2, EBR settings^{*3} are retained, but program mode or erase mode is aborted at the point at which the error occurred. Program mode or erase mode cannot be re-entered by re-setting the P, E bit. However, PV, EV bit setting is enabled, and a transition can be made to verify mode^{*2}.

FLER bit setting conditions are as follows:

1. When the flash memory of the relevant address area is read during programming/erasing (including vector read and instruction fetch)
2. Immediately after exception handling (excluding an illegal reset or trap instruction and exception handling at zero division) during programming/erasing
3. When a SLEEP instruction (including software standby) is executed during programming/erasing
4. When the CPU releases the bus to the DMAC, refresh controller, and external bus master during programming/erasing

Error protection is released only by a reset ($\overline{\text{RES}}$ pin or WDT reset) and in hardware standby mode.

- Notes:
1. State in which the P bit or E bit in FLMCR1 is set to 1. Note that NMI input is disabled in this state.
 2. It is possible to perform a program-verify operation on the 128 bytes being programmed, or an erase-verify on the block being erased.
 3. FLMCR1 and EBR can be written to. However, the registers are initialized if a transition is made to software standby mode while in the error-protected state.

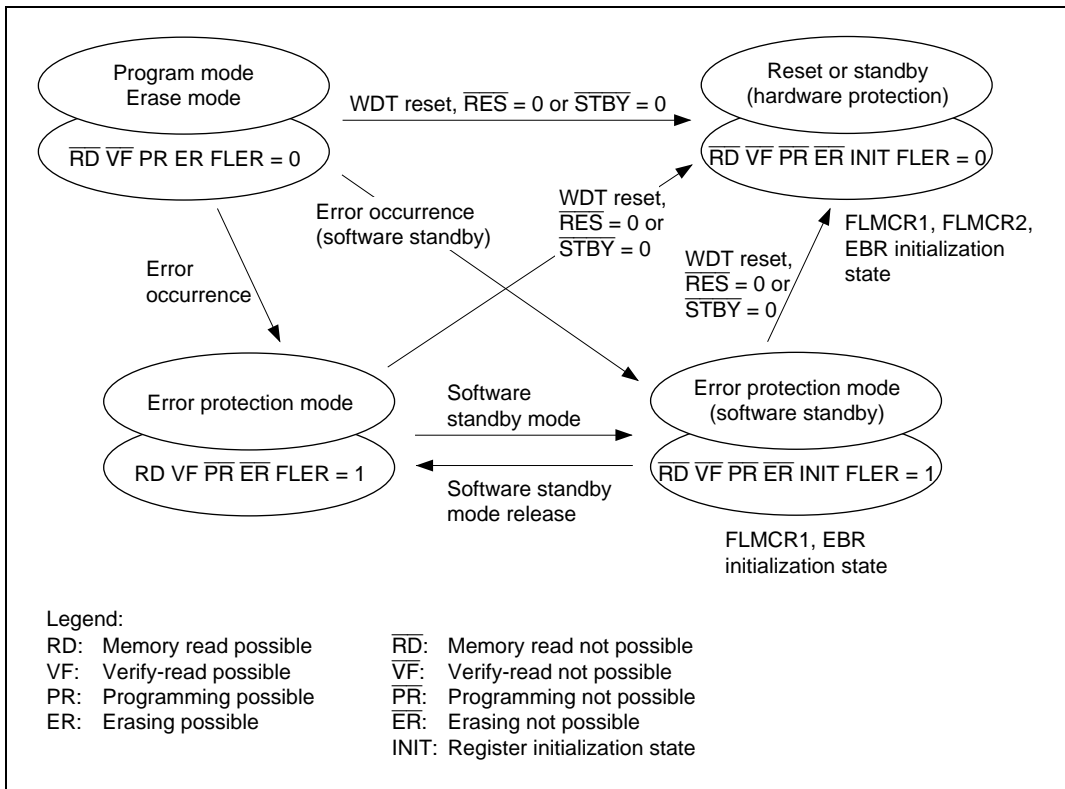

Figure 18.15 Flash Memory State Transitions

(When High Level Is Applied to FWE Pin in Mode 5, 6, and 7 (On-Chip ROM Enabled))

The error protection function is invalid for abnormal operations other than the FLER bit setting conditions. Also, if a certain time has elapsed before this protection state is entered, damage may already have been caused to the flash memory. Consequently, this function cannot provide complete protection against damage to flash memory.

To prevent such abnormal operations, therefore, it is necessary to ensure correct operation in accordance with the program/erase algorithm, with the flash write enable (FWE) voltage applied, and to conduct constant monitoring for MCU errors, internally and externally, using the watchdog timer or other means. There may also be cases where the flash memory is in an erroneous programming or erroneous erasing state at the point of transition to this protection mode, or where programming or erasing is not properly carried out because of an abort. In cases such as these, a forced recovery (program rewrite) must be executed using boot mode. However, it may also happen that boot mode cannot be normally initiated because of overprogramming or overerasing.

18.8.4 NMI Input Disable Conditions

While flash memory is being programmed/erased (P bit or E bit in FLMCR1 is set) and the boot program is executing in the boot mode^{*1}, all interrupts including NMI input must be disabled because the programming/erasing have priority.

This is done to avoid the following operation states:

1. Generation of an interrupt during programming/erasing violates the program/erase algorithms and normal operation can not longer be assured.
2. Vector-read cannot be carried out normally^{*2} during interrupt exception handling during programming/erasing and the microcomputer runs away as a result.
3. If an interrupt is generated during boot program execution, the normal boot mode sequence cannot be executed.

With above reasons, there are conditions that exceptionally disable NMI inputs only in the on-board programming mode. However, this does not assure normal programming/erasing and microcomputer operation.

Thus, when the flash memory is programmed/erased, all interrupt requests (exception handling and bus release), including NMI, inside and outside the microcomputer, must be disabled. NMI interrupt is also disabled in the error-protected state and when the P bit or E bit in FLMCR1 is retained during flash memory emulation by RAM.

Notes: 1. Indicates the period up to branching to the on-chip RAM boot program area (H'FFEF10). (This branch occurs immediately after programming control program transfer was completed.)

Therefore, after branching to RAM area, NMI input is enabled in states other than the program/erase state. Thus, interrupt requests inside and outside the microcomputer must be disabled until initial writing by programming control program (writing of vector table and NMI processing program, etc.) is completed.

2. In this case, vector read is not performed normally for the following two reasons:
 - The correct value cannot be read even by reading the flash memory during programming/erasing (P bit or E bit in FLMCR1 is set). (Value is undefined.)
 - If a value has not yet been written to the interrupt vector table, interrupt exception handling will not be performed correctly.

18.9 Flash Memory Emulation in RAM

As flash memory programming and erasing takes time, it may be difficult to carry out tuning by writing parameters and other data in real time. In this case, real-time programming of flash memory can be emulated by overlapping part of RAM (H'FFF000–H'FFF3FF) onto a small block area in flash memory. This RAM area change is executed by means of bits 3 to 1 in the RAM control register (RAMCR). After the RAM area change, access is possible both from the area overlapped onto flash memory and from the original area (H'FFF000–H'FFF3FF). For details of RAMCR and the RAM area setting method, see section 18.5.4, RAM Control Register (RAMCR).

Example of Emulation of Real-Time Flash Memory Programming

In the following example, RAM area H'FFF000–H'FFF3FF is overlapped onto flash memory area EB2 (H'000800–H'000BFF).

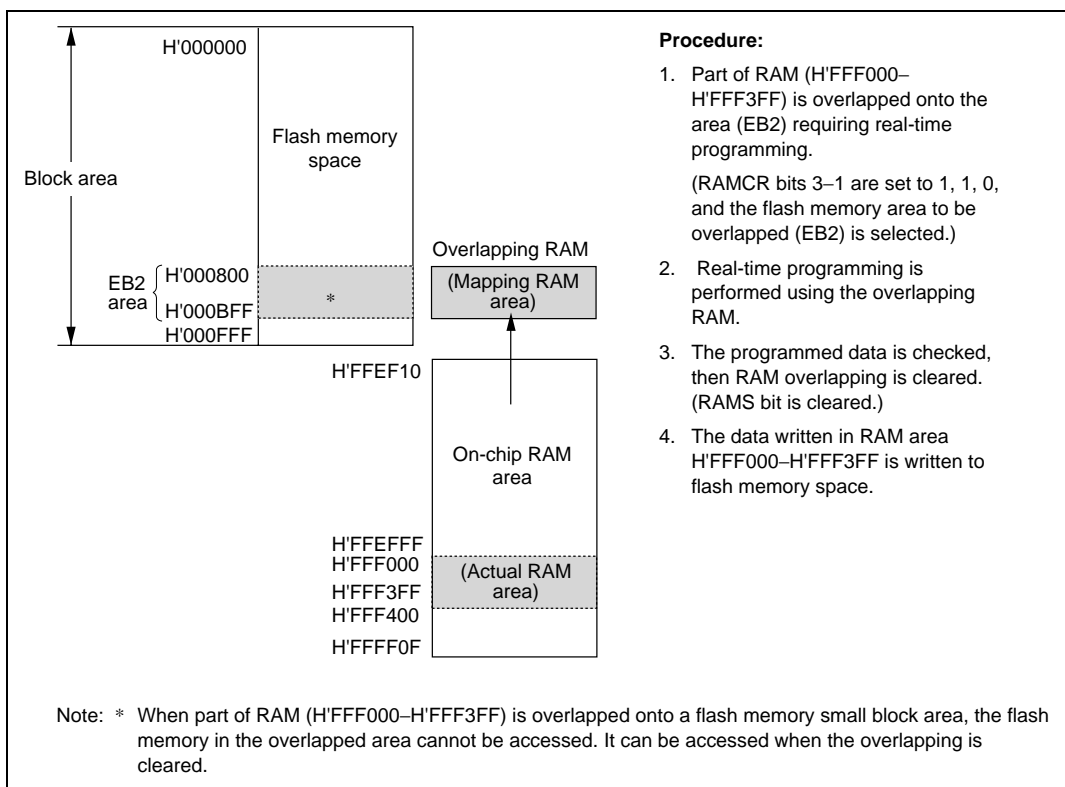

Figure 18.16 Example of RAM Overlap Operation

Notes on Using the Emulation Function by RAM

1. When the RAMS bit is set to 1, program/erase protection is enabled for all blocks regardless of the value of RAM2 and RAM1 (emulation protection). In this state, setting the P or E bit in flash memory control register 1 (FLMCR1), will not cause a transition to program mode or erase mode. When actually programming or erasing a flash memory area, the RAMS bit should be cleared to 0.
2. A RAM area cannot be erased by execution of software in accordance with the erase algorithm while flash memory emulation in RAM is being used.
3. Block area EB0 includes the vector table. When performing RAM emulation, the vector table is needed by the overlap RAM.
4. Flash write enable (FWE) application and releasing
As in on-board programming mode, care is required when applying and releasing FWE to prevent erroneous programming or erasing. To prevent erroneous programming and erasing due to program runaway during FWE application, in particular, the watchdog timer should be set when the PSU, P, ESU, or E bit in FLMCR1 is set to 1, even while the emulation function is being used. For details, see section 18.11, Notes on Flash Memory Programming/Erasing.
5. Prohibited conditions of NMI input
When the emulation function is used, NMI input is prohibited when the P bit or E bit in FLMCR1 is set to 1, in the same way as with normal programming and erasing. The P and E bits are cleared by a reset (including a watchdog timer reset), in standby mode, when a high level is not being input to the FWE pin, or when the SWE bit in FLMCR1 is 0, while a high level is being input to the FWE pin.

18.10 Flash Memory PROM Mode

The H8/3048F-ONE has a PROM mode as well as the on-board programming modes for programming and erasing flash memory. In PROM mode, the on-chip ROM can be freely programmed using a general-purpose PROM writer that supports the Renesas Technology microcomputer device type with 128-kbyte on-chip flash memory.

18.10.1 Socket Adapters and Memory Map

In PROM mode using a PROM writer, memory reading (verification) and writing and flash memory initialization (total erasure) can be performed. For these operations, a special socket adapter is mounted in the PROM writer. The socket adapter product codes are given in table 18.13*. In the H8/3048F-ONE PROM mode, only the socket adapters shown in this table should be used.

Table 18.13 H8/3048F-ONE Socket Adapter Product Codes

Product Code	Package	Socket Adapter Product Code*	Manufacturer
HD64F3048BF	100-pin QFP	ME3064ESHF1H	Minato Electronics
HD64F3048BVF	(FP-100B)	ME3024ESHF1H	
HD64F3048BTE	100-pin TQFP	ME3064ESNF1H	
HD64F3048BVTE	(TFP-100B)	ME3024ESNF1H	
HD64F3048BF	100-pin QFP	HF306BQ100D4001	Data IO Japan
HD64F3048BVF	(FP-100B)	HF302BQ100D4001	
HD64F3048BTE	100-pin TQFP	HF306BT100D4001	
HD64F3048BVTE	(TFP-100B)	HF302BT100D4001	

Note: * Use of the wrong socket adapter may destroy the chip.

Figure 18.17 shows the memory map in PROM mode.

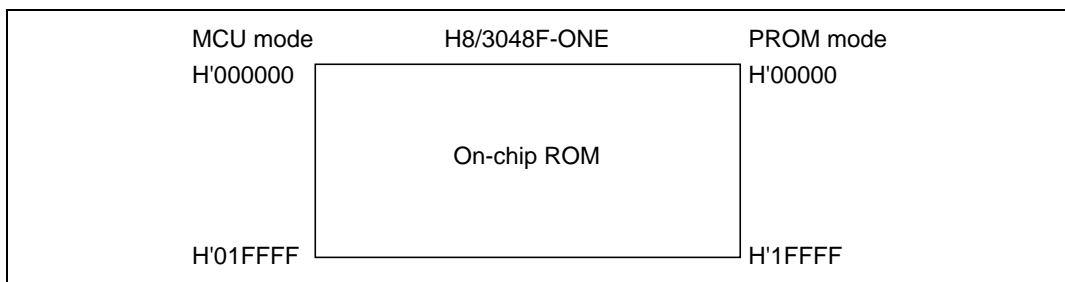

Figure 18.17 Memory Map in PROM Mode

18.10.2 Notes on Use of PROM Mode

1. A write to a 128-byte programming unit in PROM mode should be performed once only. Erasing must be carried out before reprogramming an address that has already been programmed.
2. When using a PROM writer to reprogram a device on which on-board programming/erasing has been performed, it is recommended that erasing be carried out before executing programming.
3. The memory is initially in the erased state when the device is shipped by Renesas. For samples for which the erasure history is unknown, it is recommended that erasing be executed to check and correct the initialization (erase) level.
4. The H8/3048F-ONE does not support a product identification mode as used with general-purpose EPROMs, and therefore the device name cannot be set automatically in the PROM writer.
5. Refer to the instruction manual provided with the socket adapter, or other relevant documentation, for information on PROM writers and associated program versions that are compatible with the PROM mode of the H8/3048F-ONE.
6. Select a Renesas Technology 128 kbytes flash memory on-board microcomputer device type. If HN28F101 is selected, the LSI may be permanently damaged.

18.11 Notes on Flash Memory Programming/Erasing

The following describes notes when using the on-board programming mode, RAM emulation function, and PROM mode.

1. Program/erase with the specified voltage and timing.

Applied voltages in excess of the rating can permanently damage the device.

Note that the pins FWE, V_{pp} , and MD2 have different absolute maximum ratings between the H8/3048F-ONE (single power supply) and H8/3048F (dual power supply) models.

Use a PROM writer that supports the Renesas Technology 128 kbytes flash memory on-board microcomputer device type.

Do not select the HN28F101 as the PROM writer. Otherwise, 12 V will be applied to the FWE pin and this will permanently damage H8/3048F-ONE.

2. Notes on powering on/powering off (see figures 18.18 to 18.20)

Input a high level to the FWE pin after verifying V_{cc} . Before turning off V_{cc} , set the FWE pin to a low level.

When powering on and powering off the V_{cc} power supply, fix the FWE pin low and set the flash memory to the hardware protection mode.

Be sure that the powering on and powering off timing is satisfied even when the power is turned off and back on in the event of a power interruption, etc. If this timing is not satisfied, microcomputer runaway, etc., may cause overprogramming or overerasing and the memory cells may not operate normally.

3. Notes on FWE pin High/Low switching (see figures 18.18 to 18.20)

Input FWE in the state microcomputer operation is verified. If the microcomputer does not satisfy the operation confirmation state, fix the FWE pin low to set the protection mode.

To prevent erroneous programming/erasing of flash memory, note the following in FWE pin High/Low switching:

- a. Apply an input to the FWE pin after the V_{cc} voltage has stabilized within the rated voltage. If an input is applied to the FWE pin when the microcomputer V_{cc} voltage does not satisfy the rated voltage, flash memory may be erroneously programmed or erased because the microcomputer is in the unconfirmed state.
- b. Apply an input to the FWE pin when the oscillation has stabilized (after the oscillation stabilization time).

When turning on the V_{cc} power, apply an input to the FWE pin after holding the \overline{RES} pin at a low level during the oscillation stabilization time. Do not apply an input to the FWE pin when oscillation is stopped or unstable.

- c. In the boot mode, perform FWE pin High/Low switching during reset.
In transition to the boot mode, input FWE = high level and set MD₂ to MD₀ and RXD1 pins while the $\overline{\text{RES}}$ input is low. At this time, the FWE, MD₂ to MD₀, and RXD1 inputs must satisfy the mode programming setup time (t_{MDS}) relative to the reset clear timing. The mode programming setup time is necessary for $\overline{\text{RES}}$ reset timing even in transition from the boot mode to another mode.
In reset during operation, the $\overline{\text{RES}}$ pin must be held at a low level for at least 20 system clocks.
- d. In the user program mode, FWE = High/Low switching is possible regardless of the $\overline{\text{RES}}$ input.
FWE input switching is also possible during program execution on flash memory.
- e. Apply an input to FWE when the program is not running away.
When applying an input to the FWE pin, the program execution state must be supervised using a watchdog timer, etc.
- f. Release FWE pin input only when the SWE, ESU, PSU, EV, PV, E, and P bits in FLMCR1 are cleared.
Do not erroneously set any of bits SWE, ESU, PSU, EV, PV, E, or P when applying or releasing FWE.

4. Do not input a constant high level to the FWE pin.

To prevent erroneous programming/erasing in the event of program runaway, etc., input a high level to the FWE pin only when programming/erasing flash memory (including flash memory emulation by RAM). Avoid system configurations that constantly input a high level to the FWE pin. Handle program runaway, etc. by starting the watchdog timer so that flash memory is not overprogrammed/overerased even while a high level is input to the FWE pin.

5. Program/erase the flash memory in accordance with the recommended algorithms.

The recommended algorithms can program/erase the flash memory without applying voltage stress to the device or sacrificing the reliability of the program data.

When setting the P and E bits in FLMCR1, set the watchdog timer for program runaway, etc.

Accesses to flash memory by means of an MOV instruction, etc., are prohibited while bit P or bit E is set.

6. Do not set/clear the SWE bit while a program is executing on flash memory.

Before performing flash memory program execution or data read, clear the SWE bit.

If the SWE bit is set, the flash data can be reprogrammed, but flash memory cannot be accessed for purposes other than verify (verify during programming/erase).

Similarly perform flash memory program execution and data read after clearing the SWE bit even when using the RAM emulation function with a high level input to the FWE pin. However, RAM area that overlaps flash memory space can be read/programmed whether the SWE bit is set or cleared.

After the SWE bit is cleared, waiting time is required. For details, refer to table 21.11 in section 21.1.6, Flash Memory Characteristics.

7. Do not use an interrupt during flash memory programming or erasing.

Since programming/erase operations (including emulation by RAM) have priority when a high level is input to the FWE pin, disable all interrupt requests, including NMI. The bus release should also be disabled.

8. Do not perform additional programming. Reprogram flash memory after erasing.

With on-board programming, program to 128-byte programming unit blocks one time only. Erase all the programming unit blocks before reprogramming.

9. Before programming, check that the chip is correctly mounted in the PROM programmer.

Overcurrent damage to the device can result if the index marks on the PROM programmer socket, socket adapter, and chip are not correctly aligned.

10. Do not touch the socket adapter or chip during programming.

Touching either of these can cause contact faults and write errors.

11. A wait time of 100 μ s or more is necessary when performing a read after a transition to normal mode from program, erase, or verify mode.

12. Use byte access on the registers that control the flash memory (FLMCR1, FLMCR2, EBR, and RAMCR).

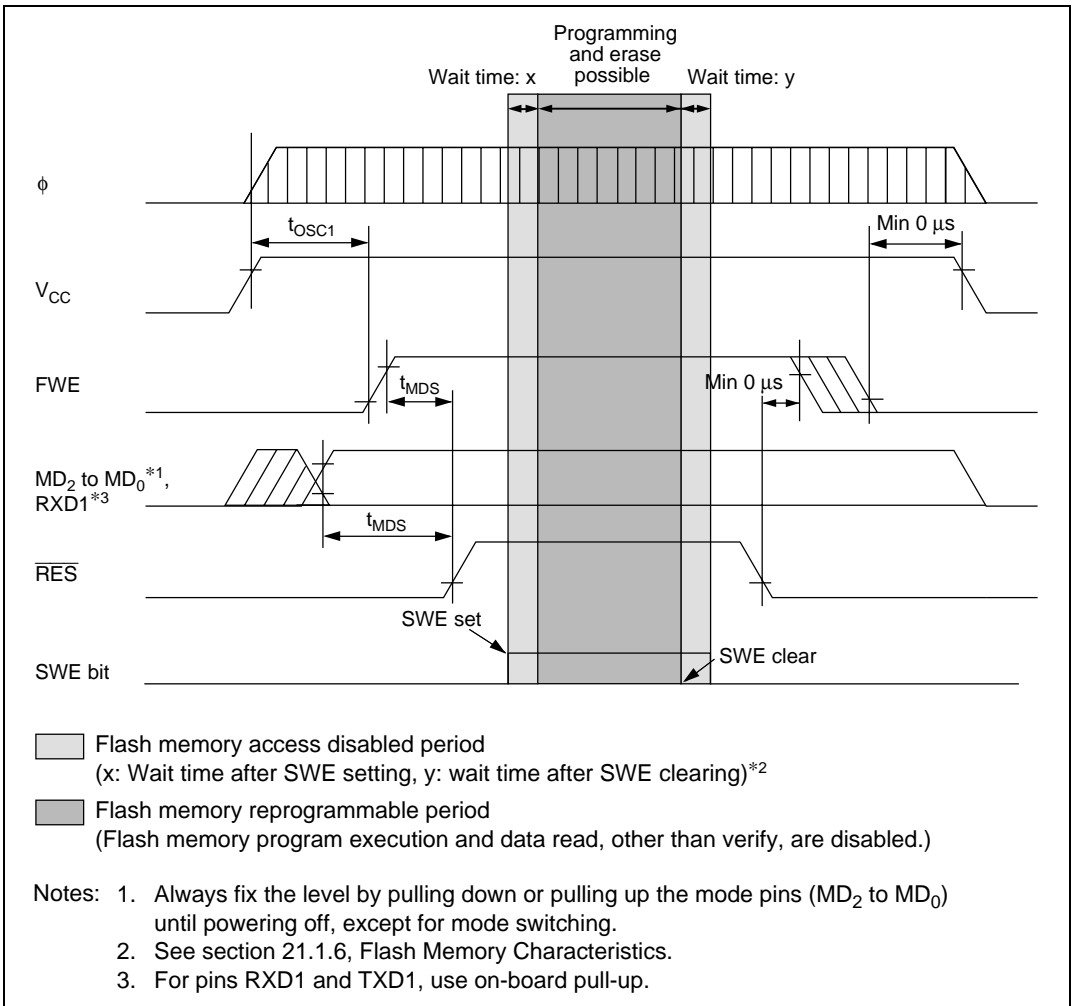

Figure 18.18 Powering On/Off Timing (Boot Mode)

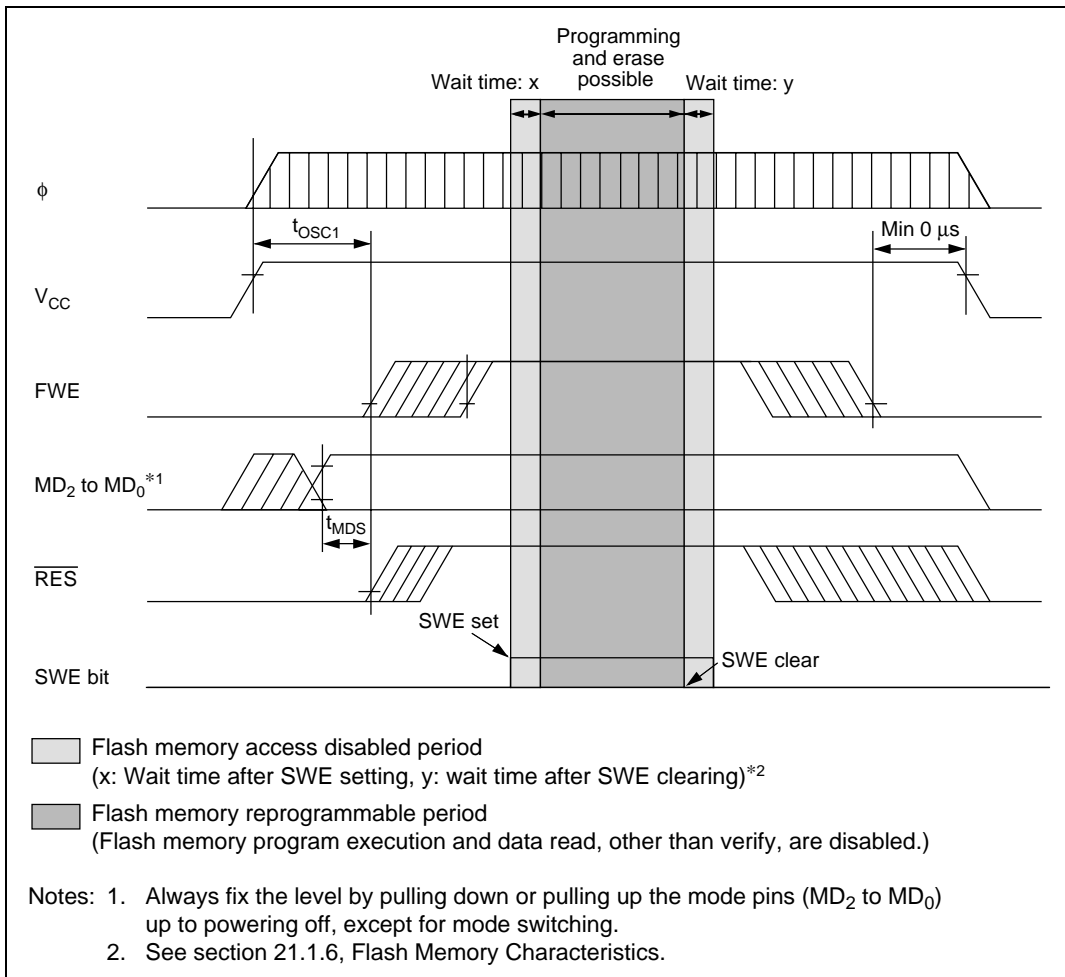

Figure 18.19 Powering On/Off Timing (User Program Mode)

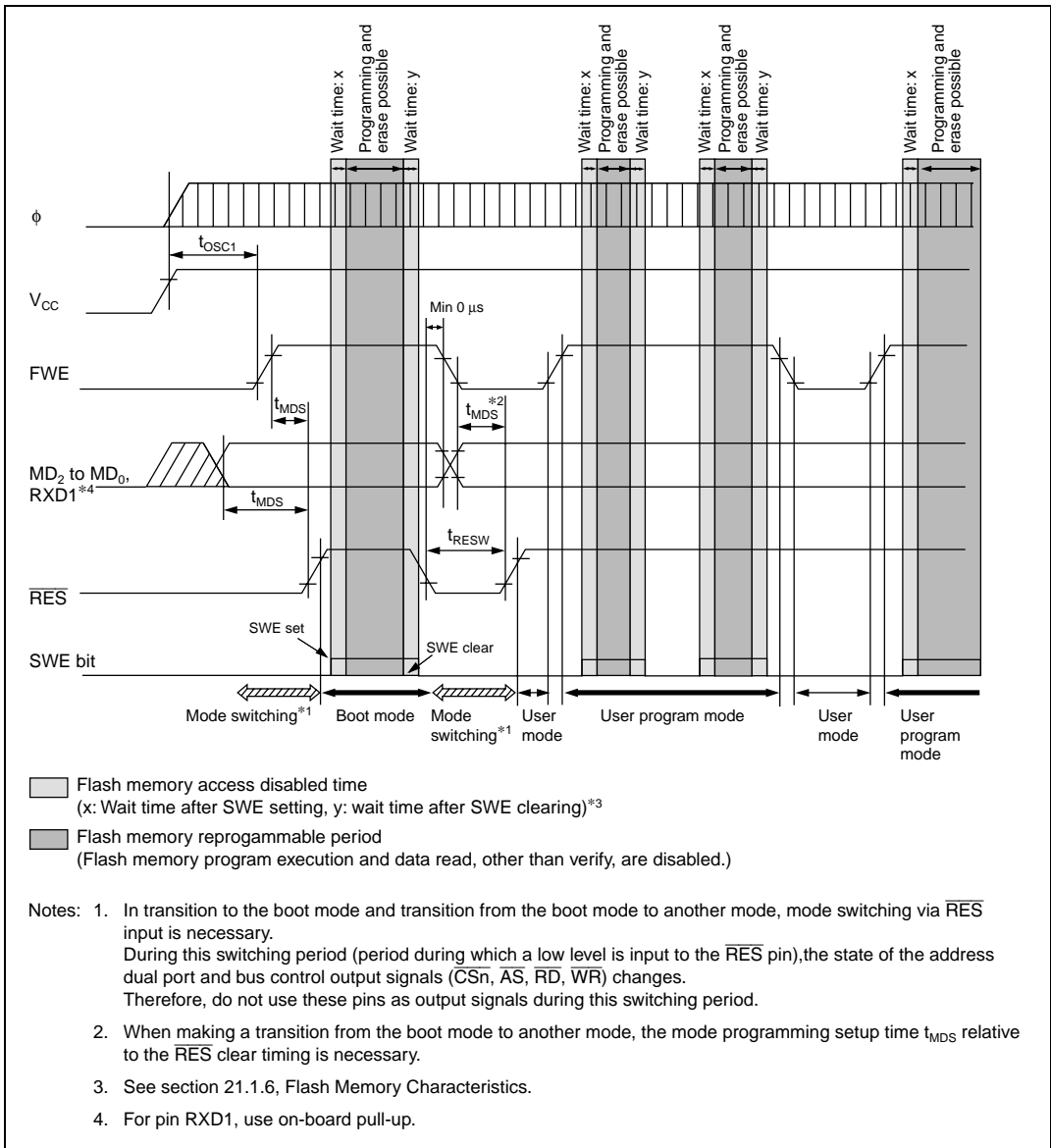

Figure 18.20 Mode Transition Timing
(Example: Boot mode → User mode ↔ User program mode)

18.12 Mask ROM (H8/3048B Mask ROM Version) Overviews

18.12.1 Block Diagram

Figure 18.21 shows a block diagram of the ROM.

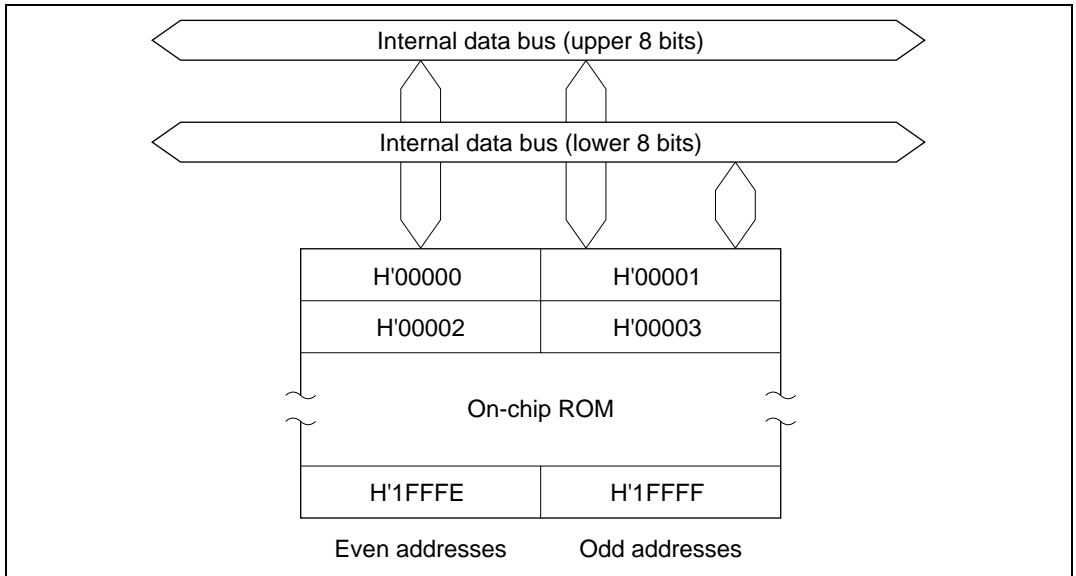

Figure 18.21 ROM Block Diagram (H8/3048B Mask ROM Version)

18.13 Notes on Ordering Mask ROM Version Chips

When ordering H8/3048B with mask ROM, note the following.

1. When ordering by means of an EPROM, use a 128-kbyte one.
2. Fill all unused addresses with H'FF and order the same ROM data size as for the 128-kbyte version. This applies to ordering by means of an EPROM and by means of data transmission.

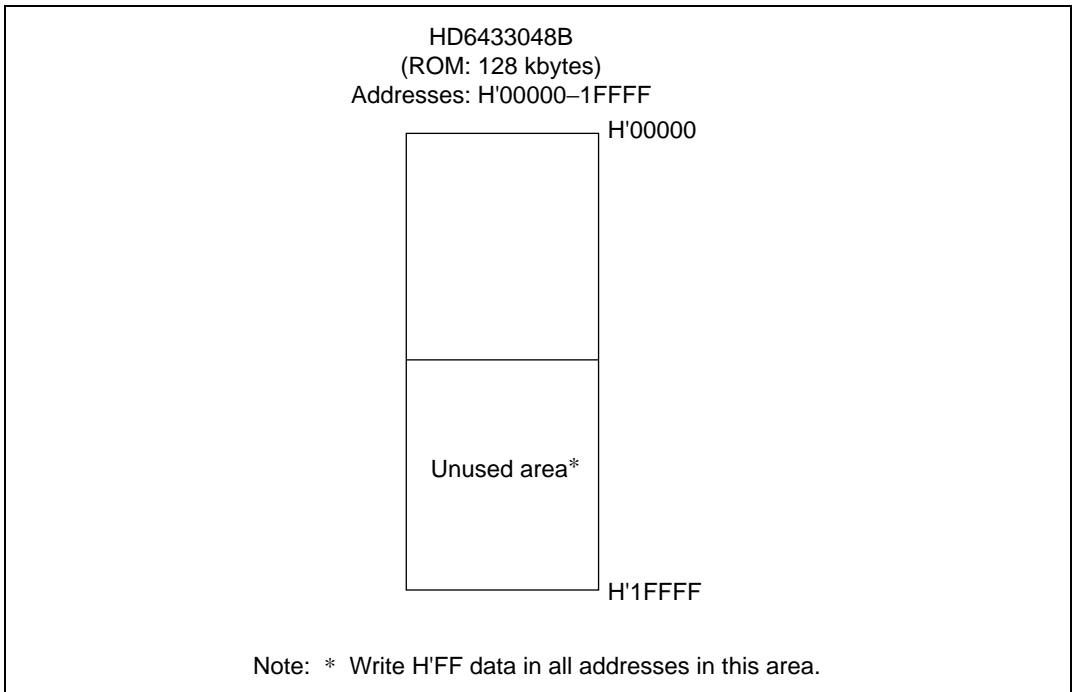

Figure 18.22 Mask ROM Addresses and Data

3. The flash memory control registers (FLMCR, EBR, RAMCR, FLMSR, FLMCR1, FLMCR2, EBR1, and EBR2) used by the versions with on-chip flash memory are not provided in the mask ROM versions. Reading the corresponding addresses in a mask ROM version will always return 1s, and writes to these addresses are disabled. This must be borne in mind when switching from a flash memory version to a mask ROM version.

18.14 Notes when Converting the F-ZTAT (Single Power Supply) Application Software to the Mask-ROM Versions

Please note the following when converting the F-ZTAT (single power supply) application software to the mask-ROM versions.

The values read from the internal registers (refer to appendix B, Internal I/O Register, Table B.1) for the F-ZTAT (single power supply) version differ as follows.

Register	Bit	Status	
		F-ZTAT (Single Power Supply) Version	Mask-ROM Version
FLMCR1	FWE	0: Application software running 1: Programming	0: Is not read out 1: Application software running

Note: This difference applies to all the F-ZTAT (single power supply) versions and all the mask-ROM versions that have different ROM size.

Section 19 Clock Pulse Generator

19.1 Overview

The H8/3048B Group has a built-in clock pulse generator (CPG) that generates the system clock (ϕ) and other internal clock signals ($\phi/2$ to $\phi/4096$). After duty adjustment, a frequency divider divides the clock frequency to generate the system clock (ϕ). The system clock is output at the ϕ pin^{*1} and furnished as a master clock to prescalers that supply clock signals to the on-chip supporting modules. Frequency division ratios of 1/1, 1/2, 1/4, and 1/8 can be selected for the frequency divider by settings in a division control register (DIVCR). Power consumption in the chip is reduced in almost direct proportion to the frequency division ratio^{*2}.

- Notes:
1. Usage of the ϕ pin differs depending on the chip operating mode and the PSTOP bit setting in the module standby control register (MSTCR). For details, see section 20.7, System Clock Output Disabling Function.
 2. The division ratio of the frequency divider can be changed dynamically during operation. The clock output at the ϕ pin also changes when the division ratio is changed. The frequency output at the ϕ pin is shown below.

$$\phi = \text{EXTAL} \times n$$

where, EXTAL: Frequency of crystal resonator or external clock signal
n: Frequency division ratio (n = 1/1, 1/2, 1/4, or 1/8)

19.1.1 Block Diagram

Figure 19.1 shows a block diagram of the clock pulse generator.

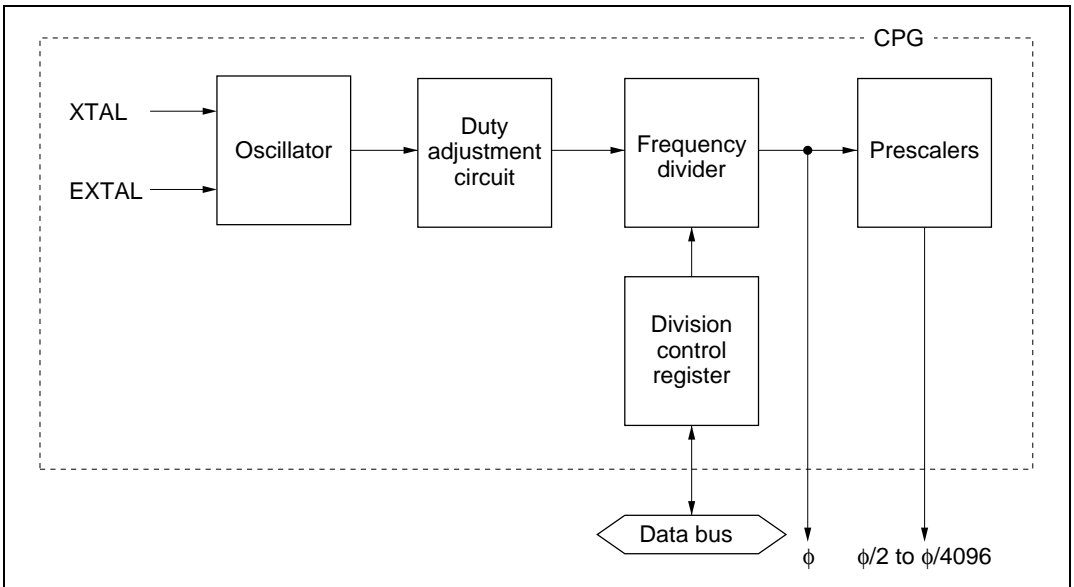

Figure 19.1 Block Diagram of Clock Pulse Generator

19.2 Oscillator Circuit

Clock pulses can be supplied by connecting a crystal resonator, or by input of an external clock signal.

19.2.1 Connecting a Crystal Resonator

Circuit Configuration

A crystal resonator can be connected as in the example in figure 19.2. The damping resistance R_d should be selected according to table 19.1, and external capacitance C_{L1} or C_{L2} to table 19.2. An AT-cut parallel-resonance crystal should be used.

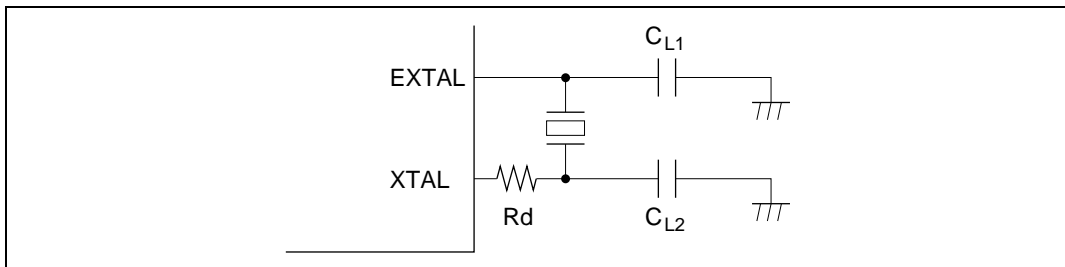

Figure 19.2 Connection of Crystal Resonator (Example)

If a crystal resonator with a frequency higher than 20 MHz in the case of the 5 V version, or 13 MHz in the case of the 3 V version, is connected, the external load capacitance values in table 19.2 should not exceed 10 [pF]. Also, in order to improve the accuracy of the oscillation frequency, a thorough study of oscillation matching evaluation, etc., should be carried out when deciding the circuit constants.

Table 19.1 Damping Resistance Value

Damping Resistance Value		Frequency f (MHz)							
		2	$2 < f \leq 4$	$4 < f \leq 8$	$8 < f \leq 10$	$10 < f \leq 13$	$13 < f \leq 16$	$16 < f \leq 18$	$18 < f \leq 25$
Rd (Ω)	H8/3048B Group	1 k	500	200	0	0	0	0	0

Note: A crystal resonator between 2 MHz and 25 MHz can be used. If the chip is to be operated at less than 2 MHz, the on-chip frequency divider should be used. (A crystal resonator of less than 2 MHz cannot be used.)

Table 19.2 External Capacitance Values

External Capacitance Value	5 V Version		3 V Version	
Frequency f (MHz)	$20 < f \leq 25$	$2 \leq f \leq 20$	$2 \leq f \leq 13$	$13 < f \leq 25$
$C_{L1} = C_{L2}$ (pF)	10	10 to 22	10 to 22	10

Crystal Resonator

Figure 19.3 shows an equivalent circuit of the crystal resonator. The crystal resonator should have the characteristics listed in table 19.3.

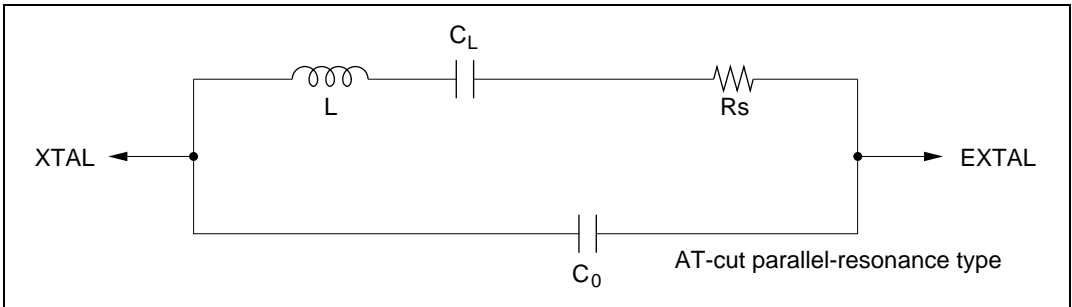

Figure 19.3 Crystal Resonator Equivalent Circuit

Table 19.3 Crystal Resonator Parameters

Frequency (MHz)	2	4	8	10	12	16	18	20	25
Rs max (Ω)	500	120	80	70	60	50	40	40	40
C₀ max (pF)	7								

Use a crystal resonator with a frequency equal to the system clock frequency (ϕ).

Notes on Board Design

When a crystal resonator is connected, the following points should be noted:

Other signal lines should be routed away from the oscillator circuit to prevent induction from interfering with correct oscillation. See figure 19.4.

When the board is designed, the crystal resonator and its load capacitors should be placed as close as possible to the XTAL and EXTAL pins.

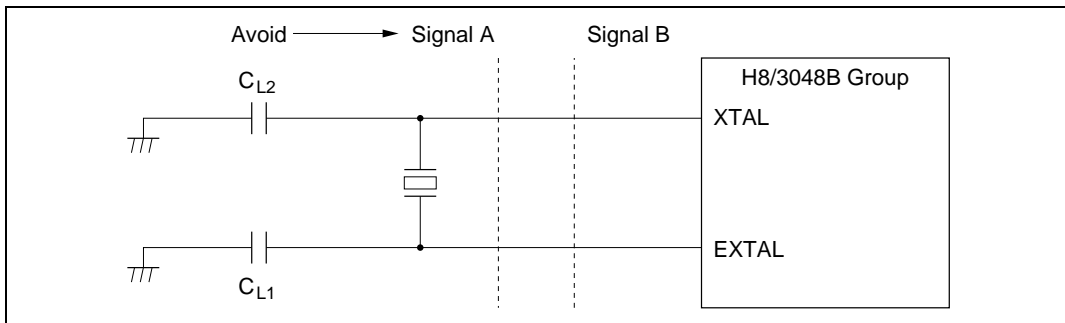

Figure 19.4 Example of Incorrect Board Design

19.2.2 External Clock Input

Circuit Configuration

An external clock signal can be input as shown in the examples in figure 19.5. The external clock is input from the EXTAL pin. If the XTAL pin is left open, the stray capacitance should not exceed 10 pF. If the stray capacitance at the XTAL pin exceeds 10 pF in configuration a, use configuration b instead and hold the clock high in standby mode.

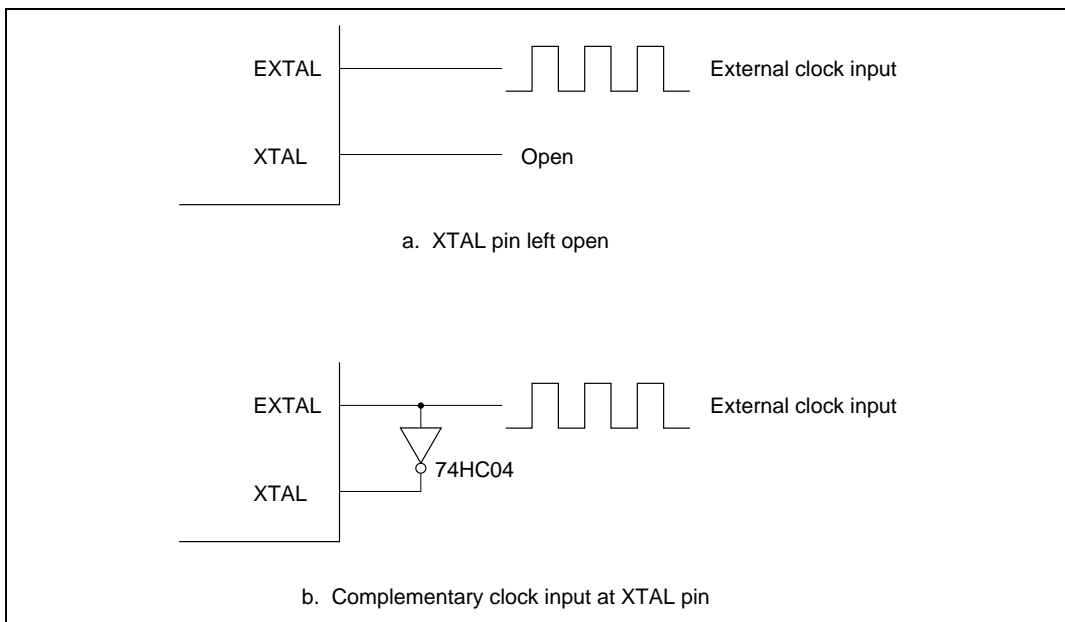

Figure 19.5 External Clock Input (Examples)

External Clock

The external clock frequency should be equal to the system clock frequency (ϕ) when not divided by the on-chip frequency divider. Table 19.4, figures 19.6 and 19.7 indicate the clock timing.

When the appropriate external clock is input via the EXTAL pin, its waveform is corrected by the on-chip oscillator and duty adjustment circuit. The resulting stable clock is output to external devices after the external clock settling time (t_{DEXT}) has passed after the clock input. The system must remain reset with the reset signal low during t_{DEXT} , while the clock output is unstable.

Table 19.4(1) Clock Timing for H8/3048B Group ($8 \text{ MHz} \leq f \leq 25 \text{ MHz}$)

Item	Symbol	$V_{\text{CC}} =$ 3.0 V to 3.6 V		$V_{\text{CC}} =$ 5.0 V $\pm 10\%$		Unit	Test Conditions
		Min	Max	Min	Max		
External clock input low pulse width	t_{EXL}	$t_{\text{cyc}}/2-5$	—	$t_{\text{cyc}}/2-5$	—	ns	Figure 19.6
External clock input high pulse width	t_{EXH}	$t_{\text{cyc}}/2-5$	—	$t_{\text{cyc}}/2-5$	—	ns	
External clock rise time	t_{EXr}	—	5	—	5	ns	
External clock fall time	t_{EXf}	—	5	—	5	ns	
Clock low pulse width	t_{CL}	0.4	0.6	0.4	0.6	t_{cyc}	Figure 21.7
Clock high pulse width	t_{CH}	0.4	0.6	0.4	0.6	t_{cyc}	
External clock output settling delay time	t_{DEXT}^*	500	—	500	—	μs	Figure 19.7

Note: * t_{DEXT} includes a $\overline{\text{RES}}$ pulse width (t_{RESW}). $t_{\text{RESW}} = 20 t_{\text{cyc}}$

Table 19.4(2) Clock Timing for H8/3048B Group (2 MHz ≤ f < 8 MHz)

Item	Symbol	$V_{CC} =$ 3.0 V to 3.6 V		$V_{CC} =$ 5.0 V ±10%		Unit	Test Conditions	
		Min	Max	Min	Max			
External clock input low pulse width	t_{EXL}	57	—	57	—	ns	Figure 19.6	
External clock input high pulse width	t_{EXH}	57	—	57	—	ns		
External clock rise time	t_{EXr}	—	5	—	5	ns		
External clock fall time	t_{EXf}	—	5	—	5	ns		
Clock low pulse width	t_{CL}	0.4	0.6	0.4	0.6	t_{cyc}	$\phi \geq 5$ MHz	Figure 21.7
		80	—	80	—	ns	$\phi < 5$ MHz	
Clock high pulse width	t_{CH}	0.4	0.6	0.4	0.6	t_{cyc}	$\phi \geq 5$ MHz	
		80	—	80	—	ns	$\phi < 5$ MHz	
External clock output settling delay time	t_{DEXT}^*	500	—	500	—	μs	Figure 19.7	

Note: * t_{DEXT} includes a \overline{RES} pulse width (t_{RESW}). $t_{RESW} = 20 t_{cyc}$

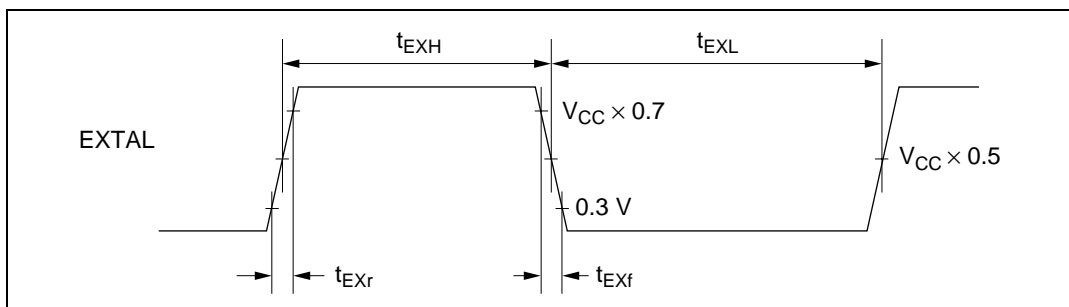
**Figure 19.6 External Clock Input Timing**

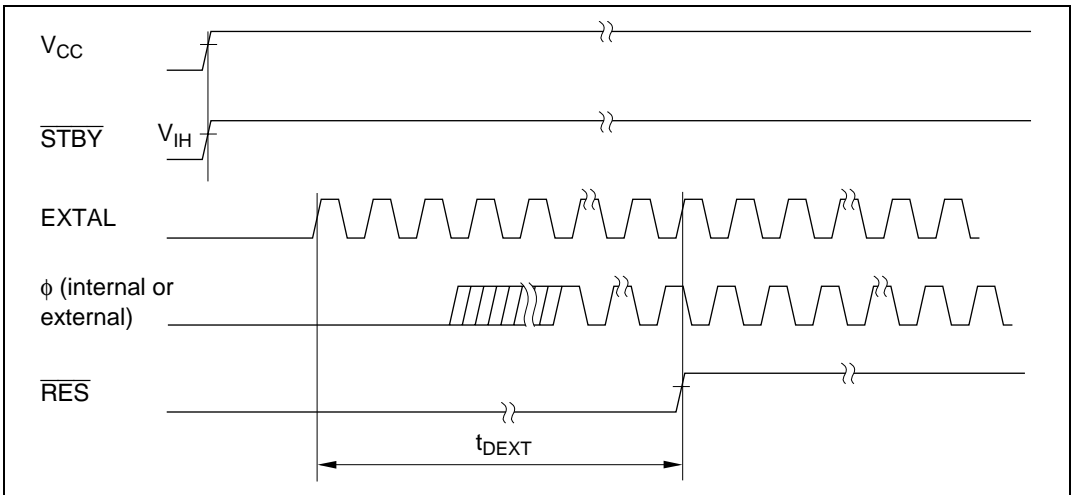

Figure 19.7 External Clock Output Settling Delay Timing

19.3 Duty Adjustment Circuit

When the oscillator frequency is 5 MHz or higher, the duty adjustment circuit adjusts the duty cycle of the clock signal from the oscillator to generate the signal that becomes the system clock.

19.4 Prescalers

The prescalers divide the system clock (ϕ) to generate internal clocks ($\phi/2$ to $\phi/4096$).

19.5 Frequency Divider

The frequency divider divides the duty-adjusted clock signal to generate the system clock (ϕ). The frequency division ratio can be changed dynamically by modifying the value in DIVCR, as described below. Power consumption in the chip is reduced in almost direct proportion to the frequency division ratio. The system clock generated by the frequency divider can be output at the ϕ pin.

19.5.1 Register Configuration

Table 19.5 summarizes the frequency division register.

Table 19.5 Frequency Division Register

Address*	Name	Abbreviation	R/W	Initial Value
H'FF5D	Division control register	DIVCR	R/W	H'FC

Note: * The lower 16 bits of the address are shown.

19.5.2 Division Control Register (DIVCR)

DIVCR is an 8-bit readable/writable register that selects the division ratio of the frequency divider.

Bit	7	6	5	4	3	2	1	0
	—	—	—	—	—	—	DIV1	DIV0
Initial value	1	1	1	1	1	1	0	0
Read/Write	—	—	—	—	—	—	R/W	R/W

Reserved bits

Divide bits 1 and 0
 These bits select the frequency division ratio

DIVCR is initialized to H'FC by a reset and in hardware standby mode. It is not initialized in software standby mode.

Bits 7 to 2—Reserved: Read-only bits, always read as 1.

Bits 1 and 0—Divide (DIV1 and DIV0): These bits select the frequency division ratio, as follows.

Bit 1: DIV1	Bit 0: DIV0	Frequency Division Ratio
0	0	1/1 (Initial value)
	1	1/2
1	0	1/4
	1	1/8

19.5.3 Usage Notes

The DIVCR setting changes the ϕ frequency, so note the following points.

- Select a frequency division ratio that stays within the assured operation range specified for the clock cycle time t_{cyc} in the AC electrical characteristics. Note that ϕ_{MIN} must be in the lower limit of the clock frequency range. Avoid settings that give system clock frequencies less than the lower limit.

Table 19.6 shows the comparison with the clock frequency range for each version.

Table 19.6 Comparison with the Clock Frequency Ranges in the H8/3048 Group and H8/3048B Group

ROM type		F-ZTAT		ZTAT	Mask ROM				
Product type		H8/3048 F-ONE	H8/3048F	H8/3048	H8/3048 Mask ROM Version	H8/3047 Mask ROM Version	H8/3045 Mask ROM Version	H8/3044 Mask ROM Version	H8/3048B Mask ROM Version
Guaranteed clock frequency range	4.5–5.5 V	2–25 MHz	1–16 MHz	1–18 MHz	1–18 MHz				2–25 MHz
	3.15–5.5 V	—		1–13 MHz	1–13 MHz				—
	2.7–5.5 V	—	1–8 MHz	1–8 MHz	1–8 MHz				—
	3.0–3.6 V	2–25 MHz	—	—	—				2–25 MHz
Crystal oscillation range		2–25 MHz	2–16 MHz	2–18 MHz	2–18 MHz				2–25 MHz

- All on-chip module operations are based on ϕ . Note that the timing of timer operations, serial communication, and other time-dependent processing differs before and after any change in the division ratio. The waiting time for exit from software standby mode also changes when the division ratio is changed. For details, see section 20.4.3, Selection of Waiting Time for Exit from Software Standby Mode.

Section 20 Power-Down State

20.1 Overview

The H8/3048B Group has a power-down state that greatly reduces power consumption by halting the CPU, and a module standby function that reduces power consumption by selectively halting on-chip modules.

The power-down state includes the following three modes:

- Sleep mode
- Software standby mode
- Hardware standby mode

The module standby function can halt on-chip supporting modules independently of the power-down state. The modules that can be halted are the ITU, SCIO, SCII, DMAC, refresh controller, and A/D converter.

Table 20.1 indicates the methods of entering and exiting the power-down modes and module standby mode, and gives the status of the CPU and on-chip supporting modules in each mode.

Table 20.1 Power-Down State and Module Standby Function

State															
Mode	Entering Conditions	Clock	CPU	CPU Registers	DMAC	Refresh Controller	ITU	SCI0	SCI1	A/D	Other Modules	RAM	φ Clock Output	I/O Ports	Exiting Conditions
Sleep mode	SLEEP instruction executed while SSBY = 0 in SYSCR	Active	Halted	Held	Active	Active	Active	Active	Active	Active	Active	Held	φ output	Held	<ul style="list-style-type: none"> • Interrupt • RES • STBY
Software standby mode	SLEEP instruction executed while SSBY = 1 in SYSCR	Halted	Halted	Held	Halted and reset	Halted and held*1	Halted and reset	Halted and reset	Halted and reset	Halted and reset	Halted and reset	Held	High output	Held	<ul style="list-style-type: none"> • NMI • IRQ₀ to IRQ₂ • RES • STBY
Hardware standby mode	Low input at STBY pin	Halted	Halted	Undetermined	Halted and reset	Halted and reset	Halted and reset	Halted and reset	Halted and reset	Halted and reset	Halted and reset	Held*3	High impedance	High impedance	<ul style="list-style-type: none"> • STBY • RES
Module standby	Corresponding bit set to 1 in MSTCR	Active	Active	—	Halted*2 and reset	Halted*2 and held*1	Halted*2 and reset	Halted*2 and reset	Halted*2 and reset	Halted*2 and reset	Halted*2 and reset	—	High impedance*2	—	<ul style="list-style-type: none"> • STBY • RES • Clear MSTCR bit to 0*4

Legend:

SYSCR: System control register

SSBY: Software standby bit

MSTCR: Module standby control register

Notes: 1. RTCNT and bits 7 and 6 of RTMCSR are initialized. Other bits and registers hold their previous states.

2. State in which the corresponding MSTCR bit was set to 1. For details see section 20.2.2, Module Standby Control Register (MSTCR).

3. The RAME bit must be cleared to 0 in SYSCR before the transition from the program execution state to hardware standby mode.

4. When a MSTCR bit is set to 1, the registers of the corresponding on-chip supporting module are initialized. To restart the module, first clear the MSTCR bit to 0, then set up the module registers again.

20.2 Register Configuration

The H8/3048B Group has a system control register (SYSCR) that controls the power-down state, and a module standby control register (MSTCR) that controls the module standby function. Table 20.2 summarizes these registers.

Table 20.2 Control Register

Address*	Name	Abbreviation	R/W	Initial Value
H'FFF2	System control register	SYSCR	R/W	H'0B
H'FF5E	Module standby control register	MSTCR	R/W	H'40

Note: * Lower 16 bits of the address.

20.2.1 System Control Register (SYSCR)

Bit	7	6	5	4	3	2	1	0
	SSBY	STS2	STS1	STS0	UE	NMIEG	—	RAME
Initial value	0	0	0	0	1	0	1	1
Read/Write	R/W	R/W	R/W	R/W	R/W	R/W	—	R/W

RAM enable

Reserved bit

NMI edge select

User bit enable

Standby timer select 2 to 0
These bits select the waiting time at exit from software standby mode

Software standby
Enables transition to software standby mode

SYSCR is an 8-bit readable/writable register. Bit 7 (SSBY) and bits 6 to 4 (STS2 to STS0) control the power-down state. For information on the other SYSCR bits, see section 3.3, System Control Register (SYSCR).

Bit 7—Software Standby (SSBY): Enables transition to software standby mode. When software standby mode is exited by an external interrupt, this bit remains set to 1 after the return to normal operation. To clear this bit, write 0.

Bit 7: SSBY	Description	
0	SLEEP instruction causes transition to sleep mode	(Initial value)
1	SLEEP instruction causes transition to software standby mode	

Bits 6 to 4—Standby Timer Select (STS2 to STS0): These bits select the length of time the CPU and on-chip supporting modules wait for the clock to settle when software standby mode is exited by an external interrupt. If the clock is generated by a crystal resonator, set these bits according to the clock frequency so that the waiting time will be at least 7 ms. See table 20.3.

If an external clock is used, select the setting so that the waiting time is 100 μ s or more according to the clock frequency.

Bit 6: STS2	Bit 5: STS1	Bit 4: STS0	Description
0	0	0	Waiting time = 8,192 states (Initial value)
		1	Waiting time = 16,384 states
	1	0	Waiting time = 32,768 states
		1	Waiting time = 65,536 states
1	0	0	Waiting time = 131,072 states
		1	Waiting time = 262,144 states
	1	0	Waiting time = 1,024 states
		1	Illegal setting

20.2.2 Module Standby Control Register (MSTCR)

MSTCR is an 8-bit readable/writable register that controls output of the system clock (ϕ). It also controls the module standby function, which places individual on-chip supporting modules in the standby state. Module standby can be designated for the ITU, SCIO, SCII, DMAC, refresh controller, and A/D converter modules.

Bit	7	6	5	4	3	2	1	0
	PSTOP	—	MSTOP5	MSTOP4	MSTOP3	MSTOP2	MSTOP1	MSTOP0
Initial value	0	1	0	0	0	0	0	0
Read/Write	R/W	—	R/W	R/W	R/W	R/W	R/W	R/W

Reserved bit
 ϕ clock stop
 Enables or disables output of the system clock

Module standby 5 to 0
 These bits select modules to be placed in standby

MSTCR is initialized to H'40 by a reset and in hardware standby mode. It is not initialized in software standby mode.

Bit 7— ϕ Clock Stop (PSTOP): Enables or disables output of the system clock (ϕ).

Bit 1: PSTOP	Description
0	System clock output is enabled (Initial value)
1	System clock output is disabled

Bit 6—Reserved: Read-only bit, always read as 1.

Bit 5—Module Standby 5 (MSTOP5): Selects whether to place the ITU in standby.

Bit 5: MSTOP5	Description
0	ITU operates normally (Initial value)
1	ITU is in standby state

Bit 4—Module Standby 4 (MSTOP4): Selects whether to place SCI0 in standby.

Bit 4: MSTOP4	Description	
0	SCI0 operates normally	(Initial value)
1	SCI0 is in standby state	

Bit 3—Module Standby 3 (MSTOP3): Selects whether to place SCI1 in standby.

Bit 3: MSTOP3	Description	
0	SCI1 operates normally	(Initial value)
1	SCI1 is in standby state	

Bit 2—Module Standby 2 (MSTOP2): Selects whether to place the DMAC in standby.

Bit 2: MSTOP2	Description	
0	DMAC operates normally	(Initial value)
1	DMAC is in standby state	

Bit 1—Module Standby 1 (MSTOP1): Selects whether to place the refresh controller in standby.

Bit 1: MSTOP1	Description	
0	Refresh controller operates normally	(Initial value)
1	Refresh controller is in standby state	

Bit 0—Module Standby 0 (MSTOP0): Selects whether to place the A/D converter in standby.

Bit 0: MSTOP0	Description	
0	A/D converter operates normally	(Initial value)
1	A/D converter is in standby state	

20.3 Sleep Mode

20.3.1 Transition to Sleep Mode

When the SSBY bit is cleared to 0 in SYSCR, execution of the SLEEP instruction causes a transition from the program execution state to sleep mode. Immediately after executing the SLEEP instruction the CPU halts, but the contents of its internal registers are retained. The DMA controller (DMAC), refresh controller, and on-chip supporting modules do not halt in sleep mode. Modules which have been placed in standby by the module standby function, however, remain halted.

20.3.2 Exit from Sleep Mode

Sleep mode is exited by an interrupt, or by input at the $\overline{\text{RES}}$ or $\overline{\text{STBY}}$ pin.

Exit by Interrupt: An interrupt terminates sleep mode and causes a transition to the interrupt exception handling state. Sleep mode is not exited by an interrupt source in an on-chip supporting module if the interrupt is disabled in the on-chip supporting module. Sleep mode is not exited by an interrupt other than NMI if the interrupt is masked by the I and UI bits in CCR and IPR.

Exit by $\overline{\text{RES}}$ Input: Low input at the $\overline{\text{RES}}$ pin exits from sleep mode to the reset state.

Exit by $\overline{\text{STBY}}$ Input: Low input at the $\overline{\text{STBY}}$ pin exits from sleep mode to hardware standby mode.

20.4 Software Standby Mode

20.4.1 Transition to Software Standby Mode

To enter software standby mode, execute the SLEEP instruction while the SSBY bit is set to 1 in SYSCR.

In software standby mode, current dissipation is reduced to an extremely low level because the CPU, clock, and on-chip supporting modules all halt. The DMAC and on-chip supporting modules are reset. As long as the specified voltage is supplied, however, CPU register contents and on-chip RAM data are retained. The settings of the I/O ports and refresh controller* are also held.

Note: * RTCNT and bits 7 and 6 of RTMCSR are initialized. Other bits and registers hold their previous states.

When the WDT is used as a watchdog timer ($WT/\overline{IT} = 1$), the TME bit must be cleared to 0 before setting SSBY. Also, when setting TME to 1, SSBY should be cleared to 0.

Clear the BRLE bit in BRCR (inhibiting bus release) before making a transition to software standby mode.

20.4.2 Exit from Software Standby Mode

Software standby mode can be exited by input of an external interrupt at the NMI, $\overline{IRQ_0}$, $\overline{IRQ_1}$, or $\overline{IRQ_2}$ pin, or by input at the \overline{RES} or \overline{STBY} pin.

Exit by Interrupt: When an NMI, $\overline{IRQ_0}$, $\overline{IRQ_1}$, or $\overline{IRQ_2}$ interrupt request signal is received, the clock oscillator begins operating. After the oscillator settling time selected by bits STS2 to STS0 in SYSCR, stable clock signals are supplied to the entire chip, software standby mode ends, and interrupt exception handling begins. Software standby mode is not exited if the interrupt enable bits of interrupts $\overline{IRQ_0}$, $\overline{IRQ_1}$, and $\overline{IRQ_2}$ are cleared to 0, or if these interrupts are masked in the CPU.

Exit by \overline{RES} Input: When the \overline{RES} input goes low, the clock oscillator starts and clock pulses are supplied immediately to the entire chip. The \overline{RES} signal must be held low long enough for the clock oscillator to stabilize. When \overline{RES} goes high, the CPU starts reset exception handling.

Exit by \overline{STBY} Input: Low input at the \overline{STBY} pin causes a transition to hardware standby mode.

20.4.3 Selection of Waiting Time for Exit from Software Standby Mode

Bits STS2 to STS0 in SYSCR and bits DIV1 and DIV0 in DIVCR should be set as follows.

Crystal Resonator: Set STS2 to STS0, DIV1, and DIV0 so that the waiting time (for the clock to stabilize) is at least 7 ms. Table 20.3 indicates the waiting times that are selected by STS2 to STS0, DIV1, and DIV0 settings at various system clock frequencies. Refer to the clock frequency and the waiting time in which it takes for the clock to settle, as shown in table 20.3.

External Clock: Set bits STS2 to STS0, Bits DIV0, and DIV1 so that the waiting time is 100 μ s or more.

Table 20.3 Clock Frequency and Waiting Time for Clock to Settle

DIV1	DIV0	STS2	STS1	STSO	Waiting Time	25 MHz	20 MHz	18 MHz	16 MHz	12 MHz	10 MHz	8 MHz	6 MHz	4 MHz	2 MHz	Unit
0	0	0	0	0	8192 states	0.3	0.4	0.46	0.51	0.65	0.8	1.0	1.3	2.0	4.1	ms
		0	0	1	16384 states	0.7	0.8	0.91	1.0	1.3	1.6	2.0	2.7	4.1	8.2*	
		0	1	0	32768 states	1.3	1.6	1.8	2.0	2.7	3.3	4.1	5.5	8.2*	16.4	
		0	1	1	65536 states	2.6	3.3	3.6	4.1	5.5	6.6	8.2*	10.9*	16.4	32.8	
		1	0	0	131072 states	5.2	6.6	7.3*	8.2*	10.9*	13.1*	16.4	21.8	32.8	65.5	
		1	0	1	262144 states	10.5*	13.1*	14.6	16.4	21.8	26.2	32.8	43.7	65.5	131.1	
		1	1	0	1024 states	0.04	0.05	0.057	0.064	0.085	0.10	0.13	0.17	0.26	0.51	
		1	1	1						Illegal setting						
0	1	0	0	0	8192 states	0.7	0.8	0.91	1.02	1.4	1.6	2.0	2.7	4.1	8.2*	ms
		0	0	1	16384 states	1.3	1.6	1.8	2.0	2.7	3.3	4.1	5.5	8.2*	16.4	
		0	1	0	32768 states	2.6	3.3	3.6	4.1	5.5	6.6	8.2*	10.9*	16.4	32.8	
		0	1	1	65536 states	5.2	6.6	7.3*	8.2*	10.9*	13.1*	16.4	21.8	32.8	65.5	
		1	0	0	131072 states	10.5*	13.1*	14.6	16.4	21.8	26.2	32.8	43.7	65.5	131.1	
		1	0	1	262144 states	21.0	26.2	29.1	32.8	43.7	52.4	65.5	87.4	131.1	262.1	
		1	1	0	1024 states	0.08	0.10	0.11	0.13	0.17	0.20	0.26	0.34	0.51	1.0	
		1	1	1						Illegal setting						
1	0	0	0	0	8192 states	1.3	1.6	1.8	2.0	2.7	3.3	4.1	5.5	8.2*	16.4*	ms
		0	0	1	16384 states	2.6	3.3	3.6	4.1	5.5	6.6	8.2*	10.9*	16.4	32.8	
		0	1	0	32768 states	5.2	6.6	7.3*	8.2*	10.9*	13.1*	16.4	21.8	32.8	65.5	
		0	1	1	65536 states	10.5*	13.1*	14.6	16.4	21.8	26.2	32.8	43.7	65.5	131.1	
		1	0	0	131072 states	21.0	26.2	29.1	32.8	43.7	52.4	65.5	87.4	131.1	262.1	
		1	0	1	262144 states	41.9	52.4	58.3	65.5	87.4	104.9	131.1	174.8	262.1	524.3	
		1	1	0	1024 states	0.16	0.20	0.23	0.26	0.34	0.41	0.51	0.68	1.02	2.0	
		1	1	1						Illegal setting						
1	1	0	0	0	8192 states	2.6	3.3	3.6	4.1	5.5	6.6	8.2*	10.9*	16.4*	32.8*	ms
		0	0	1	16384 states	5.2	6.6	7.3*	8.2*	10.9*	13.1*	16.4	21.8	32.8	65.5	
		0	1	0	32768 states	10.5	13.1*	14.6	16.4	21.8	26.2	32.8	43.7	65.5	131.1	
		0	1	1	65536 states	21.0*	26.2	29.1	32.8	43.7	52.4	65.5	87.4	131.1	262.1	
		1	0	0	131072 states	41.9	52.4	58.3	65.5	87.4	104.9	131.1	174.8	262.1	524.3	
		1	0	1	262144 states	83.9	104.9	116.5	131.1	174.8	209.7	262.1	349.5	524.3	1048.6	
		1	1	0	1024 states	0.33	0.41	0.46	0.51	0.68	0.82	1.0	1.4	2.0	4.1	
		1	1	1						Illegal setting						

Note: * Recommended setting

20.4.4 Sample Application of Software Standby Mode

Figure 20.1 shows an example in which software standby mode is entered at the fall of NMI and exited at the rise of NMI.

With the NMI edge select bit (NMIEG) cleared to 0 in SYSCR (selecting the falling edge), an NMI interrupt occurs. Next the NMIEG bit is set to 1 (selecting the rising edge) and the SSBY bit is set to 1; then the SLEEP instruction is executed to enter software standby mode.

Software standby mode is exited at the next rising edge of the NMI signal.

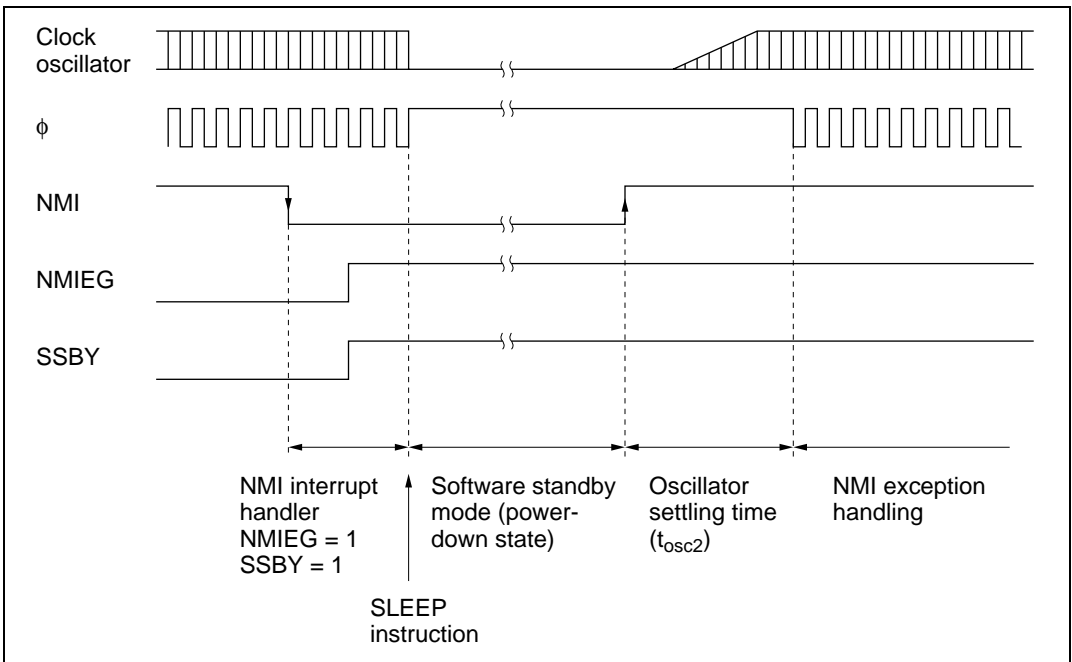

Figure 20.1 NMI Timing for Software Standby Mode (Example)

20.4.5 Note

The I/O ports retain their existing states in software standby mode. If a port is in the high output state, its output current is not reduced.

20.5 Hardware Standby Mode

20.5.1 Transition to Hardware Standby Mode

Regardless of its current state, the chip enters hardware standby mode whenever the \overline{STBY} pin goes low. Hardware standby mode reduces power consumption drastically by halting all functions of the CPU, DMAC, refresh controller, and on-chip supporting modules. All modules are reset except the on-chip RAM. As long as the specified voltage is supplied, on-chip RAM data is retained. I/O ports are placed in the high-impedance state.

Clear the RAME bit to 0 in SYSCR before \overline{STBY} goes low to retain on-chip RAM data.

The inputs at the mode pins (MD_2 to MD_0) should not be changed during hardware standby mode.

20.5.2 Exit from Hardware Standby Mode

Hardware standby mode is exited by inputs at the \overline{STBY} and \overline{RES} pins. While \overline{RES} is low, when \overline{STBY} goes high, the clock oscillator starts running. \overline{RES} should be held low long enough for the clock oscillator to settle. When \overline{RES} goes high, reset exception handling begins, followed by a transition to the program execution state.

20.5.3 Timing for Hardware Standby Mode

Figure 20.2 shows the timing relationships for hardware standby mode. To enter hardware standby mode, first drive \overline{RES} low, then drive \overline{STBY} low. To exit hardware standby mode, first drive \overline{STBY} high, wait for the clock to settle, then bring \overline{RES} from low to high.

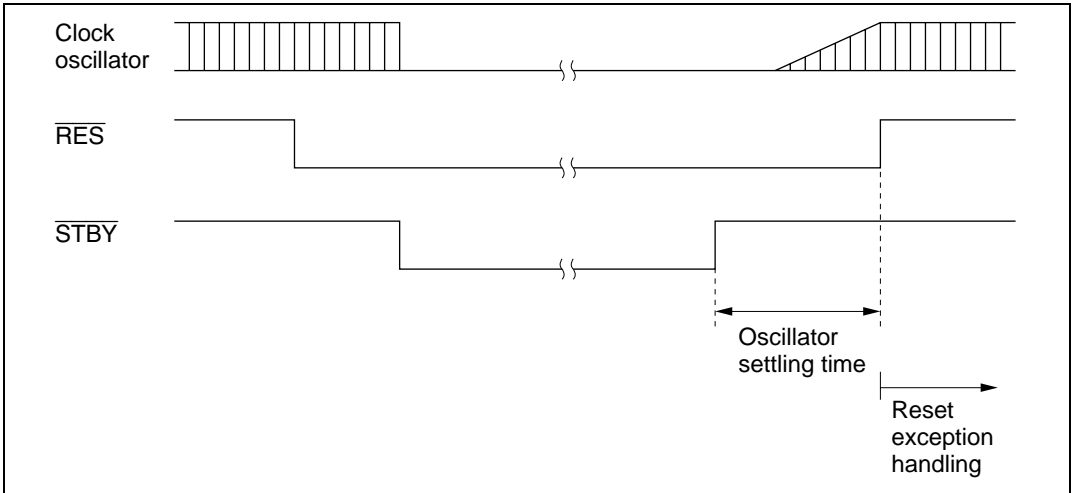

Figure 20.2 Hardware Standby Mode Timing

20.6 Module Standby Function

20.6.1 Module Standby Timing

The module standby function can halt several of the on-chip supporting modules (the ITU, SC10, SC11, DMAC, refresh controller, and A/D converter) independently of the power-down state. This standby function is controlled by bits MSTOP5 to MSTOP0 in MSTCR. When one of these bits is set to 1, the corresponding on-chip supporting module is placed in standby and halts at the beginning of the next bus cycle after the MSTCR write cycle.

20.6.2 Read/Write in Module Standby

When an on-chip supporting module is in module standby, read/write access to its registers is disabled. Read access always results in H'FF data. Write access is ignored.

20.6.3 Usage Notes

When using the module standby function, note the following points.

DMAC and Refresh Controller: When setting bit MSTOP2 or MSTOP1 to 1 to place the DMAC or refresh controller in module standby, make sure that the DMAC or refresh controller is not currently requesting the bus right. If bit MSTOP2 or MSTOP1 is set to 1 when a bus request is present, operation of the bus arbiter becomes ambiguous and a malfunction may occur.

Internal Peripheral Module Interrupt: When MSTCR is set to 1, prevent module interrupt in advance. When an on-chip supporting module is placed in standby by the module standby function, its registers, including the interrupt flag, are initialized.

Pin States: Pins used by an on-chip supporting module lose their module functions when the module is placed in module standby. What happens after that depends on the particular pin. For details, see section 9, I/O Ports. Pins that change from the input to the output state require special care. For example, if SC11 is placed in module standby, the receive data pin loses its receive data function and becomes a generic I/O pin. If its data direction bit is set to 1, the pin becomes a data output pin, and its output may collide with external serial data. Data collisions should be prevented by clearing the data direction bit to 0 or taking other appropriate action.

Register Resetting: When an on-chip supporting module is halted by the module standby function, all its registers are initialized. To restart the module, after its MSTCR bit is cleared to 0, its registers must be set up again. It is not possible to write to the registers while the MSTCR bit is set to 1.

MSTCR Access from DMAC Disabled: To prevent malfunctions, MSTCR can only be accessed from the CPU. It can be read by the DMAC, but it cannot be written by the DMAC.

20.7 System Clock Output Disabling Function

Output of the system clock (ϕ) can be controlled by the PSTOP bit in MSTCR. When the PSTOP bit is set to 1, output of the system clock halts and the ϕ pin is placed in the high-impedance state. Figure 20.3 shows the timing of the stopping and starting of system clock output. When the PSTOP bit is cleared to 0, output of the system clock is enabled. Table 20.4 indicates the state of the ϕ pin in various operating states.

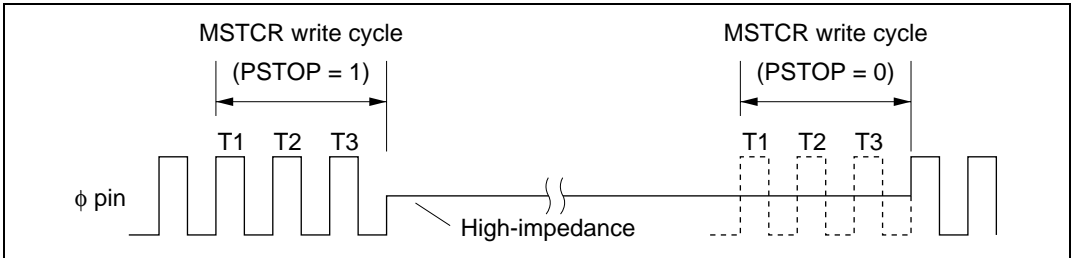

Figure 20.3 Starting and Stopping of System Clock Output

Table 20.4 ϕ Pin State in Various Operating States

Operating State	PSTOP = 0	PSTOP = 1
Hardware standby	High-impedance	High-impedance
Software standby	Always high	High-impedance
Sleep mode	System clock output	High-impedance
Normal operation	System clock output	High-impedance

Section 21 Electrical Characteristics

Table 21.1 shows the electrical characteristics of the various products in the H8/3048 Group and H8/3048B Group.

Table 21.1 Electrical Characteristics of H8/3048 Group and H8/3048B Group Products

Item		Symbol	Unit	H8/3048 Group		H8/3048B Group		
				H8/3048 F-ZTAT (Dual Power Supply)	H8/3048 H8/3047 H8/3045 H8/3044	H8/3048 ZTAT	H8/3048 F-ONE (Single Power Supply)	H8/3048B Mask ROM
Operating range	$V_{CC} = 4.5$ to 5.5 V		MHz	1 to 16	1 to 18	1 to 18	2 to 25 (5 V operation model)	2 to 25 (5 V operation model)
	$V_{CC} = 3.15$ to 5.5 V			—	1 to 13	1 to 13	—	—
	$V_{CC} = 2.7$ to 5.5 V			1 to 8	1 to 8	1 to 8	—	—
	$V_{CC} = 3.0$ to 3.6 V			—	—	—	2 to 25 (3 V operation model)	2 to 25 (3 V operation model)
Operating temperature range	Regular specifications	T_{opr}	°C	-20 to +75	-20 to +75	-20 to +75	-20 to +75 ^{*1}	-20 to +75 ^{*1}
	Wide-range specifications			-40 to +85	-40 to +85	-40 to +85	-40 to +85 ^{*1}	-40 to +85 ^{*1}
Absolute maximum ratings	V_{PP} pin rating	V_{in}		Yes	—	Yes	—	—
	FWE pin rating			—	—	—	Yes	—
	V_{CL} pin			—	—	—	Cannot be connected to power supply ^{*2} (5 V operation model only)	Cannot be connected to power supply ^{*2} (5 V operation model only)

Item		Symbol	Unit	H8/3048 Group		H8/3048B Group		
				H8/3048 F-ZTAT (Dual Power Supply)	H8/3048 H8/3047 H8/3045 H8/3044	H8/3048 ZTAT	H8/3048 F-ONE (Single Power Supply)	H8/3048B Mask ROM
Absolute maximum ratings	Power supply voltage	V_{in}	V	-0.3 to +7.0	-0.3 to +7.0	-0.3 to +7.0	-0.3 to +7.0 (5 V operation model) -0.3 to +4.6 (3 V operation model)	-0.3 to +7.0 (5 V operation model) -0.3 to +4.6 (3 V operation model)
DC characteristics	RES \bar{O} pin specification			Yes	Yes	Yes	—	Yes
	FWE pin specification			—	—	—	Yes	—
	Determination level for applying high voltage (12 V)			Yes	—	—	—	—
	Standby current ($T_a \leq 50^\circ\text{C}$)	I_{CC}^{*3}	μA	Max 5	Max 5	Max 5	Max 10	Max 10
	Standby current ($50^\circ\text{C} < T_a$)			Max 20	Max 20	Max 20	Max 80	Max 80
AC characteristics	Clock cycle time	t_{cyc}	ns	Max 1000	Max 1000	Max 1000	Max 500	Max 500
	RES \bar{E} pulse width	t_{RESW}	t_{cyc}	Min 10	Min 10	Min 10	Min 20	Min 20
	RES \bar{O} output delay time	t_{RESD}	ns	Max 100	Max 100	Max 100	—	—
	RES \bar{O} output pulse width	t_{RESOW}	t_{cyc}	Min 132	Min 132	Min 132	—	—
Flash memory characteristics ^{*4}				Refer to the H8/3048 Group Hardware Manual (revision 7.0) for details.	—	—	See table 21.11	—

- Notes: 1. The operating temperature range for flash memory programming/erasing is 0°C to +75°.
2. Connect an external capacitor between the V_{CL} pin and GND.
3. See the DC Characteristics table for current dissipation during operation.
4. Refer to the program/erase algorithms for details of flash memory characteristics.

21.1 Electrical Characteristics of H8/3048F-ONE (Single-Power Supply)

21.1.1 Absolute Maximum Ratings

Table 21.2 lists the absolute maximum ratings.

Table 21.2 Absolute Maximum Ratings

Item	Symbol	Value	Unit
Power supply voltage	V_{CC}^{*1}	5 V operation model: -0.3 to $+7.0$	V
		3 V operation model: -0.3 to $+4.6$	
Input voltage (FWE) ^{*2}	V_{in}	-0.3 to $V_{CC} + 0.3$	V
Input voltage (except for port 7) ^{*2}	V_{in}	-0.3 to $V_{CC} + 0.3$	V
Input voltage (port 7)	V_{in}	-0.3 to $AV_{CC} + 0.3$	V
Reference voltage	V_{REF}	-0.3 to $AV_{CC} + 0.3$	V
Analog power supply voltage	AV_{CC}	5 V operation model: -0.3 to $+7.0$	V
		3 V operation model: -0.3 to $+4.6$	
Analog input voltage	V_{AN}	-0.3 to $AV_{CC} + 0.3$	V
Operating temperature	T_{opr}	Regular specifications: -20 to $+75^{*3}$	°C
		Wide-range specifications: -40 to $+85^{*3}$	
Storage temperature	T_{stg}	-55 to $+125$	°C

Caution: Permanent damage to the chip may result if absolute maximum ratings are exceeded.

- Notes:
1. Do not apply the power supply voltage to the V_{CL} pin in 5 V operation models. Connect an external capacitor between this pin and GND.
 2. 12 V must not be applied to any pin, as this may cause permanent damage to the device.
 3. The operating temperature range for flash memory programming/erasing is 0°C to $+75^{\circ}\text{C}$.

21.1.2 DC Characteristics

Table 21.3 lists the DC characteristics. Table 21.4 lists the permissible output currents.

Table 21.3 DC Characteristics (1)

Conditions: $V_{CC} = 5.0\text{ V} \pm 10\%$, $AV_{CC} = 5.0\text{ V} \pm 10\%$, $V_{REF} = 4.5\text{ V}$ to AV_{CC} ,
 $V_{SS} = AV_{SS} = 0\text{ V}^{*1}$, $T_a = -20^\circ\text{C}$ to $+75^\circ\text{C}$ (regular specifications), $T_a = -40^\circ\text{C}$ to
 $+85^\circ\text{C}$ (wide-range specifications), ($T_a = 0^\circ\text{C}$ to $+75^\circ\text{C}$ during program/erase)

Item	Symbol	Min	Typ	Max	Unit	Test Conditions	
Schmitt trigger input voltages	Port A, P8 ₂ to P8 ₀ , PB ₃ to PB ₀	V_T^-	1.0	—	—	V	
		V_T^+	—	—	$V_{CC} \times 0.7$	V	
		$V_T^+ - V_T^-$	0.4	—	—	V	
Input high voltage	RES, STBY, FWE, NMI, MD ₂ to MD ₀	V_{IH}	$V_{CC} - 0.7$	—	$V_{CC} + 0.3$	V	
	EXTAL		$V_{CC} \times 0.7$	—	$V_{CC} + 0.3$	V	
	Port 7		2.0	—	$AV_{CC} + 0.3$	V	
	Ports 1 to 6, 9, P8 ₄ , P8 ₃ , PB ₇ to PB ₄		2.0	—	$V_{CC} + 0.3$	V	
Input low voltage	RES, STBY, MD ₂ to MD ₀ , FWE	V_{IL}	-0.3	—	0.5	V	
	NMI, EXTAL, ports 1 to 7, 9, P8 ₄ , P8 ₃ , PB ₇ to PB ₄		-0.3	—	0.8	V	
Output high voltage	All output pins	V_{OH}	$V_{CC} - 0.5$	—	—	V	$I_{OH} = -200\ \mu\text{A}$
			3.5	—	—	V	$I_{OH} = -1\ \text{mA}$
Output low voltage	All output pins	V_{OL}	—	—	0.4	V	$I_{OL} = 1.6\ \text{mA}$
			Ports 1, 2, 5, and B	—	—	1.0	V
Input leakage current	STBY, NMI, RES, FWE, MD ₂ to MD ₀	$ I_{in} $	—	—	1.0	μA	$V_{in} = 0.5$ to $V_{CC} - 0.5\ \text{V}$
	Port 7		—	—	1.0	μA	$V_{in} = 0.5$ to $AV_{CC} - 0.5\ \text{V}$

Item		Symbol	Min	Typ	Max	Unit	Test Conditions	
Three-state leakage current (off state)	Ports 1 to 6, 8 to B	$ I_{TSL} $	—	—	1.0	μA	$V_{in} = 0.5$ to $V_{CC} - 0.5$ V	
Input pull-up MOS current	Ports 2, 4, and 5	$-I_p$	50	—	300	μA	$V_{in} = 0$ V	
Input capacitance	FWE	C_{in}	—	—	60	pF	$V_{in} = 0$ V, $f = f_{min}$, $T_a = 25^\circ\text{C}$	
	NMI		—	—	50	pF		
	All input pins except NMI, FWE		—	—	15	pF		
Current dissipation*2	Normal operation*5	I_{CC}^{*6}	—	45	60	mA	$f = 25$ MHz	
	Sleep mode		—	35	50	mA		
	Module standby mode*4		—	20	25	mA		
	Standby mode*3			—	1	10	μA	$T_a \leq 50^\circ\text{C}$
				—	—	80	μA	$50^\circ\text{C} < T_a$
Analog power supply current	During A/D conversion	AI_{CC}	—	0.5	1.5	mA	$AV_{CC} = 5.0$ V	
	During A/D and D/A conversion		—	0.5	1.5	mA		
	Idle		—	0.01	5.0	μA	DASTE = 0	
Reference current	During A/D conversion	AI_{CC}	—	0.4	0.8	mA	$V_{REF} = 5.0$ V	
	During A/D and D/A conversion		—	1.5	3.0	mA		
	Idle		—	0.01	5.0	μA	DASTE = 0	
RAM standby voltage		V_{RAM}	2.0	—	—	V		

- Notes: 1. If the A/D and D/A converters are not used, do not leave the AV_{CC} , AV_{SS} , and V_{REF} pins open. Connect AV_{CC} and V_{REF} to V_{CC} , and connect AV_{SS} to V_{SS} .
2. Current dissipation values are for $V_{IH} \text{ min} = V_{CC} - 0.5$ V and $V_{IL} \text{ max} = 0.5$ V with all output pins unloaded and the on-chip pull-up transistors in the off state.
3. The values are for $V_{RAM} \leq V_{CC} < 4.5$ V, $V_{IH} \text{ min} = V_{CC} \times 0.9$, and $V_{IL} \text{ max} = 0.3$ V.
4. Module standby current values apply in sleep mode with all modules halted.
5. The current dissipation value for flash memory program/erase operations ($T_a = 0^\circ\text{C}$ to $+75^\circ\text{C}$) is 10 mA (max.) greater than the current dissipation value for normal operation.

6. I_{cc} depends on V_{cc} and f , according to the following expressions.

$$I_{cc} \text{ max. (normal operation)} = 10.0 \text{ [mA]} + 0.36 \text{ [mA/(MHz} \times \text{V)]} \times V_{cc} \times f$$

$$I_{cc} \text{ max. (sleep mode)} = 10.0 \text{ [mA]} + 0.29 \text{ [mA/(MHz} \times \text{V)]} \times V_{cc} \times f$$

$$I_{cc} \text{ max. (sleep mode and module standby mode)} = 10.0 \text{ [mA]} + 0.11 \text{ [mA/(MHz} \times \text{V)]} \times V_{cc} \times f$$

The typical values of current dissipation are reference values.

Table 21.3 DC Characteristics (2)

Conditions: $V_{CC} = 3.0\text{ V to }3.6\text{ V}$, $AV_{CC} = 3.0\text{ V to }3.6\text{ V}$, $V_{REF} = 3.0\text{ V to }AV_{CC}$,
 $V_{SS} = AV_{SS} = 0\text{ V}^{*1}$, $T_a = -20^\circ\text{C to }+75^\circ\text{C}$ (regular specifications), $T_a = -40^\circ\text{C to }+85^\circ\text{C}$ (wide-range specifications), ($T_a = 0^\circ\text{C to }+75^\circ\text{C}$ during program/erase)

Item	Symbol	Min	Typ	Max	Unit	Test Conditions	
Schmitt trigger input voltages	Port A, P8 ₂ to P8 ₀ , PB ₃ to PB ₀	V_T^-	$V_{CC} \times 0.2$	—	—	V	
		V_T^+	—	—	$V_{CC} \times 0.7$	V	
		$V_T^+ - V_T^-$	$V_{CC} \times 0.05$	—	—	V	
Input high voltage	\overline{RES} , \overline{STBY} , FWE, NMI, MD ₂ to MD ₀	V_{IH}	$V_{CC} \times 0.9$	—	$V_{CC} + 0.3$	V	
	EXTAL		$V_{CC} \times 0.7$	—	$V_{CC} + 0.3$	V	
	Port 7		$V_{CC} \times 0.7$	—	$AV_{CC} + 0.3$	V	
	Ports 1 to 6, 9, P8 ₄ , P8 ₃ , PB ₇ to PB ₄		$V_{CC} \times 0.7$	—	$V_{CC} + 0.3$	V	
Input low voltage	\overline{RES} , \overline{STBY} , MD ₂ to MD ₀ , FWE	V_{IL}	-0.3	—	$V_{CC} \times 0.1$	V	
	NMI, EXTAL, ports 1 to 7, 9, P8 ₄ , P8 ₃ , PB ₇ to PB ₄		-0.3	—	$V_{CC} \times 0.2$	V	
Output high voltage	All output pins	V_{OH}	$V_{CC} - 0.5$	—	—	V	$I_{OH} = -200\ \mu\text{A}$
			$V_{CC} - 1.0$	—	—	V	$I_{OH} = -1\ \text{mA}$
Output low voltage	All output pins Ports 1, 2, 5, and B	V_{OL}	—	—	0.4	V	$I_{OL} = 1.6\ \text{mA}$
			—	—	1.0	V	$I_{OL} = 5\ \text{mA}$
Input leakage current	\overline{STBY} , NMI, \overline{RES} , FWE, MD ₂ to MD ₀	$ I_{in} $	—	—	1.0	μA	$V_{in} = 0.5\text{ to }V_{CC} - 0.5\text{ V}$
	Port 7		—	—	1.0	μA	$V_{in} = 0.5\text{ to }AV_{CC} - 0.5\text{ V}$
Three-state leakage current (off state)	Ports 1 to 6, 8 to B	$ I_{TSI} $	—	—	1.0	μA	$V_{in} = 0.5\text{ to }V_{CC} - 0.5\text{ V}$

Item		Symbol	Min	Typ	Max	Unit	Test Conditions	
Input pull-up MOS current	Ports 2, 4, and 5	$-I_p$	10	—	300	μA	$V_{in} = 0\text{ V}$	
Input capacitance	FWE	C_{in}	—	—	60	pF	$V_{in} = 0\text{ V}$, $f = f_{min}$, $T_a = 25^\circ\text{C}$	
	NMI		—	—	50	pF		
	All input pins except NMI, FWE		—	—	15	pF		
Current dissipation ^{*2}	Normal operation ^{*5}	I_{CC}^{*6}	—	40	60	mA	$f = 25\text{ MHz}$	
	Sleep mode		—	30	50	mA		
	Module standby mode ^{*4}		—	20	25	mA		
	Standby mode ^{*3}			—	1	10	μA	$T_a \leq 50^\circ\text{C}$
				—	—	80	μA	$50^\circ\text{C} < T_a$
Analog power supply current	During A/D conversion	AI_{CC}	—	0.5	1.5	mA	$AV_{CC} = 3.3\text{ V}$	
	During A/D and D/A conversion		—	0.5	1.5	mA		
	Idle		—	0.01	5	μA	DASTE = 0	
Reference current	During A/D conversion	AI_{CC}	—	0.4	0.8	mA	$V_{REF} = 3.3\text{ V}$	
	During A/D and D/A conversion		—	1.5	3	mA		
	Idle		—	0.01	5	μA	DASTE = 0	
RAM standby voltage		V_{RAM}	2.0	—	—	V		

- Notes: 1. If the A/D and D/A converters are not used, do not leave the AV_{CC} , AV_{SS} , and V_{REF} pins open. Connect AV_{CC} and V_{REF} to V_{CC} , and connect AV_{SS} to V_{SS} .
2. Current dissipation values are for $V_{IH\ min} = V_{CC} - 0.5\text{ V}$ and $V_{IL\ max} = 0.5\text{ V}$ with all output pins unloaded and the on-chip pull-up transistors in the off state.
3. The values are for $V_{RAM} \leq V_{CC} < 3.0\text{ V}$, $V_{IH\ min} = V_{CC} \times 0.9$, and $V_{IL\ max} = 0.3\text{ V}$.
4. Module standby current values apply in sleep mode with all modules halted.
5. The current dissipation value for flash memory program/erase operations ($T_a = 0^\circ\text{C}$ to $+75^\circ\text{C}$) is 10 mA (max.) greater than the current dissipation value for normal operation.
6. I_{CC} depends on V_{CC} and f , according to the following expressions.
 I_{CC} max. (normal operation) = $6.0\text{ [mA]} + 0.60\text{ [mA/(MHz} \times \text{V)]} \times V_{CC} \times f$
 I_{CC} max. (sleep mode) = $6.0\text{ [mA]} + 0.49\text{ [mA/(MHz} \times \text{V)]} \times V_{CC} \times f$
 I_{CC} max. (sleep mode and module standby mode) = $6.0\text{ [mA]} + 0.21\text{ [mA/(MHz} \times \text{V)]} \times V_{CC} \times f$
 The typical values of current dissipation are reference values.

Table 21.4 Permissible Output Currents

Condition A: $V_{CC} = 3.0\text{ V to }3.6\text{ V}$, $AV_{CC} = 3.0\text{ V to }3.6\text{ V}$, $V_{REF} = 3.0\text{ V to }AV_{CC}$,
 $V_{SS} = AV_{SS} = 0\text{ V}$, $T_a = -20^\circ\text{C to }+75^\circ\text{C}$ (regular specifications), $T_a = -40^\circ\text{C to }+85^\circ\text{C}$ (wide-range specifications)

Condition B: $V_{CC} = 5.0\text{ V} \pm 10\%$, $AV_{CC} = 5.0\text{ V} \pm 10\%$, $V_{REF} = 4.5\text{ V to }AV_{CC}$,
 $V_{SS} = AV_{SS} = 0\text{ V}$, $T_a = -20^\circ\text{C to }+75^\circ\text{C}$ (regular specifications), $T_a = -40^\circ\text{C to }+85^\circ\text{C}$ (wide-range specifications)

Item	Symbol	Conditions A, B			Unit	
		Min	Typ	Max		
Permissible output low current (per pin)	Ports 1, 2, 5, and B	I_{OL}	—	—	10	mA
	Other output pins		—	—	2.0	mA
Permissible output low current (total)	Total of 28 pins in ports 1, 2, 5, and B	ΣI_{OL}	—	—	80	mA
	Total of all output pins, including the above		—	—	120	mA
Permissible output high current (per pin)	All output pins	I_{OH}	—	—	2.0	mA
Permissible output high current (total)	Total of all output pins	ΣI_{OH}	—	—	40	mA

- Notes: 1. To protect chip reliability, do not exceed the output current values in table 21.4.
 2. When driving a darlington pair or LED, always insert a current-limiting resistor in the output line, as shown in figures 21.1 and 21.2.

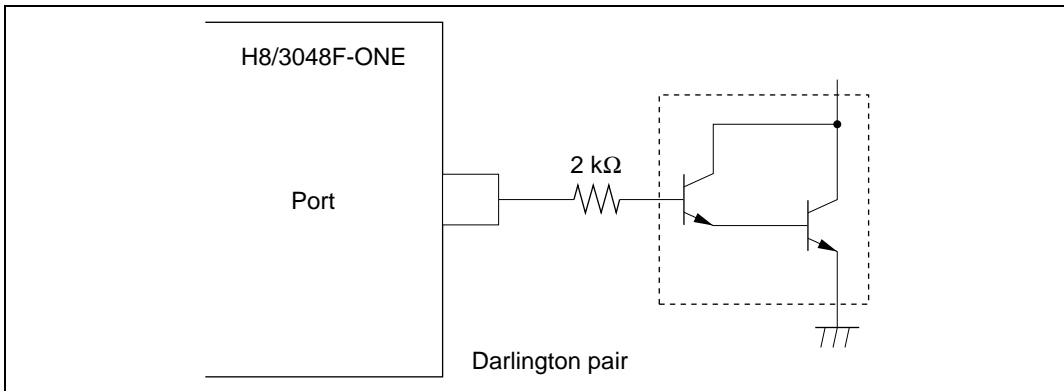

Figure 21.1 Darlington Pair Drive Circuit (Example)

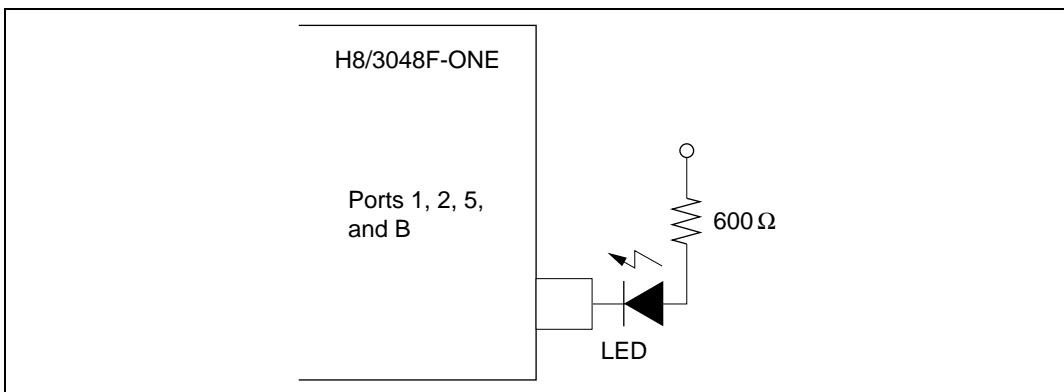

Figure 21.2 LED Drive Circuit (Example)

21.1.3 AC Characteristics

Bus timing parameters are listed in table 21.5. Refresh controller bus timing parameters are listed in table 21.6. Control signal timing parameters are listed in table 21.7. Timing parameters of the on-chip supporting modules are listed in table 21.8.

Table 21.5 Bus Timing

Condition A: $V_{CC} = 3.0\text{ V to }3.6\text{ V}$, $AV_{CC} = 3.0\text{ V to }3.6\text{ V}$, $V_{REF} = 3.0\text{ V to }AV_{CC}$,
 $V_{SS} = AV_{SS} = 0\text{ V}$, $\phi = 2\text{ MHz to }25\text{ MHz}$, $T_a = -20^\circ\text{C to }+75^\circ\text{C}$ (regular specifications), $T_a = -40^\circ\text{C to }+85^\circ\text{C}$ (wide-range specifications)

Condition B: $V_{CC} = 5.0\text{ V} \pm 10\%$, $AV_{CC} = 5.0\text{ V} \pm 10\%$, $V_{REF} = 4.5\text{ V to }AV_{CC}$,
 $V_{SS} = AV_{SS} = 0\text{ V}$, $\phi = 2\text{ MHz to }25\text{ MHz}$, $T_a = -20^\circ\text{C to }+75^\circ\text{C}$ (regular specifications), $T_a = -40^\circ\text{C to }+85^\circ\text{C}$ (wide-range specifications)

Item	Symbol	Condition A		Condition B		Unit	Test Conditions
		25 MHz		25 MHz			
		Min	Max	Min	Max		
Clock cycle time	t_{cyc}	40	500	40	500	ns	Figure 21.7
Clock pulse low width	t_{CL}	10	—	10	—		Figure 21.8
Clock pulse high width	t_{CH}	10	—	10	—		
Clock rise time	t_{CR}	—	10	—	10		
Clock fall time	t_{CF}	—	10	—	10		
Address delay time	t_{AD}	—	28	—	25		
Address hold time	t_{AH}	$0.5t_{cyc} - 20$	—	$0.5t_{cyc} - 20$	—		
Address strobe delay time	t_{ASD}	—	25	—	25		
Write strobe delay time	t_{WSD}	—	25	—	25		
Strobe delay time	t_{SD}	—	25	—	25		
Write data strobe pulse width 1	t_{WSW1}	$1.0t_{cyc} - 25$	—	$1.0t_{cyc} - 25$	—		
Write data strobe pulse width 2	t_{WSW2}	$1.5t_{cyc} - 25$	—	$1.5t_{cyc} - 25$	—		
Address setup time 1	t_{AS1}	$0.5t_{cyc} - 20$	—	$0.5t_{cyc} - 20$	—		
Address setup time 2	t_{AS2}	$1.0t_{cyc} - 20$	—	$1.0t_{cyc} - 20$	—		
Read data setup time	t_{RDS}	15	—	15	—		
Read data hold time	t_{RDH}	0	—	0	—		

Item	Symbol	Condition A		Condition B		Unit	Test Conditions
		25 MHz		25 MHz			
		Min	Max	Min	Max		
Write data delay time	t_{WDD}	—	35	—	35	ns	Figure 21.7
Write data setup time 1	t_{WDS1}	$1.0t_{cyc} - 30$	—	$1.0t_{cyc} - 30$	—		Figure 21.8
Write data setup time 2	t_{WDS2}	$0.5t_{cyc} - 30$	—	$0.5t_{cyc} - 30$	—		
Write data hold time	t_{WDH}	$0.5t_{cyc} - 15$	—	$0.5t_{cyc} - 15$	—		
Read data access time 1	t_{ACC1}	—	$1.5t_{cyc} - 40$	—	$1.5t_{cyc} - 40$		
Read data access time 2	t_{ACC2}	—	$2.5t_{cyc} - 40$	—	$2.5t_{cyc} - 40$		
Read data access time 3	t_{ACC3}	—	$1.0t_{cyc} - 28$	—	$1.0t_{cyc} - 28$		
Read data access time 4	t_{ACC4}	—	$2.0t_{cyc} - 32$	—	$2.0t_{cyc} - 32$		
Precharge time	t_{PCH}	$1.0t_{cyc} - 20$	—	$1.0t_{cyc} - 20$	—		
Wait setup time	t_{WTS}	25	—	25	—	ns	Figure 21.9
Wait hold time	t_{WTH}	5	—	5	—		
Bus request setup time	t_{BROS}	25	—	25	—	ns	Figure 21.21
Bus acknowledge delay time 1	t_{BACD1}	—	30	—	30		
Bus acknowledge delay time 2	t_{BACD2}	—	30	—	30		
Bus-floating time	t_{BZD}	—	40	—	40		

Table 21.6 Refresh Controller Bus Timing

Condition A: $V_{CC} = 3.0\text{ V to }3.6\text{ V}$, $AV_{CC} = 3.0\text{ V to }3.6\text{ V}$, $V_{REF} = 3.0\text{ V to }AV_{CC}$,
 $V_{SS} = AV_{SS} = 0\text{ V}$, $\phi = 2\text{ MHz to }25\text{ MHz}$, $T_a = -20^\circ\text{C to }+75^\circ\text{C}$ (regular specifications), $T_a = -40^\circ\text{C to }+85^\circ\text{C}$ (wide-range specifications)

Condition B: $V_{CC} = 5.0\text{ V} \pm 10\%$, $AV_{CC} = 5.0\text{ V} \pm 10\%$, $V_{REF} = 4.5\text{ V to }AV_{CC}$,
 $V_{SS} = AV_{SS} = 0\text{ V}$, $\phi = 2\text{ MHz to }25\text{ MHz}$, $T_a = -20^\circ\text{C to }+75^\circ\text{C}$ (regular specifications), $T_a = -40^\circ\text{C to }+85^\circ\text{C}$ (wide-range specifications)

Item	Symbol	Condition A		Condition B		Unit	Test Conditions
		25 MHz		25 MHz			
		Min	Max	Min	Max		
$\overline{\text{RAS}}$ delay time 1 ^{*1}	t_{RAD1}	—	20	—	18	ns	Figure 21.10 to Figure 21.16
$\overline{\text{RAS}}$ delay time 2 ^{*1}	t_{RAD2}	—	20	—	18		
$\overline{\text{RAS}}$ delay time 3 ^{*1}	t_{RAD3}	—	20	—	18		
Row address hold time	t_{RAH}	$0.5t_{\text{cyc}} - 5$	—	$0.5t_{\text{cyc}} - 5$	—		
$\overline{\text{RAS}}$ precharge time ^{*1}	t_{RP}	$1.0t_{\text{cyc}} - 15$	—	$1.0t_{\text{cyc}} - 15$	—		
$\overline{\text{CAS}}$ to $\overline{\text{RAS}}$ precharge time ^{*1 *2}	t_{CRP}	$1.0t_{\text{cyc}} - 15$	—	$1.0t_{\text{cyc}} - 15$	—		
$\overline{\text{CAS}}$ pulse width ^{*2}	t_{CAS}	$1.0t_{\text{cyc}} - 18$	—	$1.0t_{\text{cyc}} - 18$	—		
$\overline{\text{RAS}}$ access time ^{*1}	t_{RAC}	—	$2.0t_{\text{cyc}} - 35$	—	$2.0t_{\text{cyc}} - 35$		
Address access time	t_{AA}	—	$1.5t_{\text{cyc}} - 40$	—	$1.5t_{\text{cyc}} - 40$		
$\overline{\text{CAS}}$ access time ^{*2}	t_{CAC}	—	$1.0t_{\text{cyc}} - 30$	—	$1.0t_{\text{cyc}} - 30$		
Write data setup time 3	t_{WDS3}	$1.0t_{\text{cyc}} - 25$	—	$1.0t_{\text{cyc}} - 25$	—		
$\overline{\text{CAS}}$ setup time ^{*2}	t_{CSR}	$0.5t_{\text{cyc}} - 15$	—	$0.5t_{\text{cyc}} - 15$	—		
Read strobe delay time	t_{RSD}	—	25	—	25		
Signal rise time (all input pins except EXTAL)	t_{SR}	—	100	—	100	ns	Figure 21.18
Signal fall time (all input pins except EXTAL)	t_{SF}	—	100	—	100		

- Notes: 1. The $\overline{\text{RAS}}$ pin is assigned to the $\overline{\text{CS3}}$ pin.
2. The $\overline{\text{CAS}}$ pin is assigned to the $\overline{\text{RD}}$ pin.

Table 21.7 Control Signal Timing

Condition A: $V_{CC} = 3.0\text{ V to }3.6\text{ V}$, $AV_{CC} = 3.0\text{ V to }3.6\text{ V}$, $V_{REF} = 3.0\text{ V to }AV_{CC}$,
 $V_{SS} = AV_{SS} = 0\text{ V}$, $\phi = 2\text{ MHz to }25\text{ MHz}$, $T_a = -20^\circ\text{C to }+75^\circ\text{C}$ (regular
specifications), $T_a = -40^\circ\text{C to }+85^\circ\text{C}$ (wide-range specifications)

Condition B: $V_{CC} = 5.0\text{ V} \pm 10\%$, $AV_{CC} = 5.0\text{ V} \pm 10\%$, $V_{REF} = 4.5\text{ V to }AV_{CC}$,
 $V_{SS} = AV_{SS} = 0\text{ V}$, $\phi = 2\text{ MHz to }25\text{ MHz}$, $T_a = -20^\circ\text{C to }+75^\circ\text{C}$ (regular
specifications), $T_a = -40^\circ\text{C to }+85^\circ\text{C}$ (wide-range specifications)

Item	Symbol	Condition A		Condition B		Unit	Test Conditions
		25 MHz		25 MHz			
RES setup time	t_{RESS}	200	—	200	—	ns	Figure 21.18
RES pulse width	t_{RESW}	20	—	20	—	t_{oyc}	
Mode programming setup time	t_{MDS}	200	—	200	—	ns	
NMI setup time (NMI, \overline{IRQ}_5 to \overline{IRQ}_0)	t_{NMIS}	150	—	150	—	ns	Figure 21.20
NMI hold time (NMI, \overline{IRQ}_5 to \overline{IRQ}_0)	t_{NMIH}	10	—	10	—		
Interrupt pulse width (NMI, \overline{IRQ}_2 to \overline{IRQ}_0 when exiting software standby mode)	t_{NMIW}	200	—	200	—		
Clock oscillator settling time at reset (crystal)	t_{OSC1}	20	—	20	—	ms	Figure 21.22
Clock oscillator settling time in software standby (crystal)	t_{OSC2}	7	—	7	—	ms	Figure 20.1

Table 21.8 Timing of On-Chip Supporting Modules

Condition A: $V_{CC} = 3.0\text{ V to }3.6\text{ V}$, $AV_{CC} = 3.0\text{ V to }3.6\text{ V}$, $V_{REF} = 3.0\text{ V to }AV_{CC}$,
 $V_{SS} = AV_{SS} = 0\text{ V}$, $\phi = 2\text{ MHz to }25\text{ MHz}$, $T_a = -20^\circ\text{C to }+75^\circ\text{C}$ (regular specifications), $T_a = -40^\circ\text{C to }+85^\circ\text{C}$ (wide-range specifications)

Condition B: $V_{CC} = 5.0\text{ V} \pm 10\%$, $AV_{CC} = 5.0\text{ V} \pm 10\%$, $V_{REF} = 4.5\text{ V to }AV_{CC}$,
 $V_{SS} = AV_{SS} = 0\text{ V}$, $\phi = 2\text{ MHz to }25\text{ MHz}$, $T_a = -20^\circ\text{C to }+75^\circ\text{C}$ (regular specifications), $T_a = -40^\circ\text{C to }+85^\circ\text{C}$ (wide-range specifications)

Item	Symbol	Condition A		Condition B		Unit	Test Conditions		
		25 MHz		25 MHz					
		Min	Max	Min	Max				
DMAC	DREQ setup time	t_{DRQS}	20	—	20	—	ns	Figure 21.30	
	DREQ hold time	t_{DRQH}	10	—	10	—			
	TEND delay time 1	t_{TED1}	—	50	—	50		Figures 21.28 and 21.29	
	TEND delay time 2	t_{TED2}	—	50	—	50			
ITU	Timer output delay time	t_{TOCD}	—	50	—	50	ns	Figure 21.24	
	Timer input setup time	t_{TICS}	40	—	40	—		Figure 21.25	
	Timer clock input setup time	t_{TCKS}	40	—	40	—			
	Timer clock pulse width	Single edge	t_{TCKWH}	1.5	—	1.5	—		t_{CYC}
		Both edges	t_{TCKWL}	2.5	—	2.5	—		
SCI	Input clock cycle	Asynchronous	t_{SCYC}	4	—	4	—	t_{CYC}	Figure 21.26
		Synchronous	t_{SCYC}	6	—	6	—		
	Input clock rise time	t_{SCKr}	—	1.5	—	1.5			
	Input clock fall time	t_{SCKf}	—	1.5	—	1.5			
	Input clock pulse width	t_{SCKW}	0.4	0.6	0.4	0.6	t_{SCYC}		
	Transmit data delay time	t_{TXD}	—	100	—	100	ns	Figure 21.27	
	Receive data setup time (synchronous)	t_{RXS}	100	—	100	—			
	Receive data hold time (synchronous)	Clock input	t_{RXH}	100	—	100	—		
Clock output		t_{RXH}	0	—	0	—			
Ports and TPC	Output data delay time	t_{PWD}	—	50	—	50	ns	Figure 21.23	
	Input data setup time	t_{PRS}	50	—	50	—			
	Input data hold time	t_{PRH}	50	—	50	—			

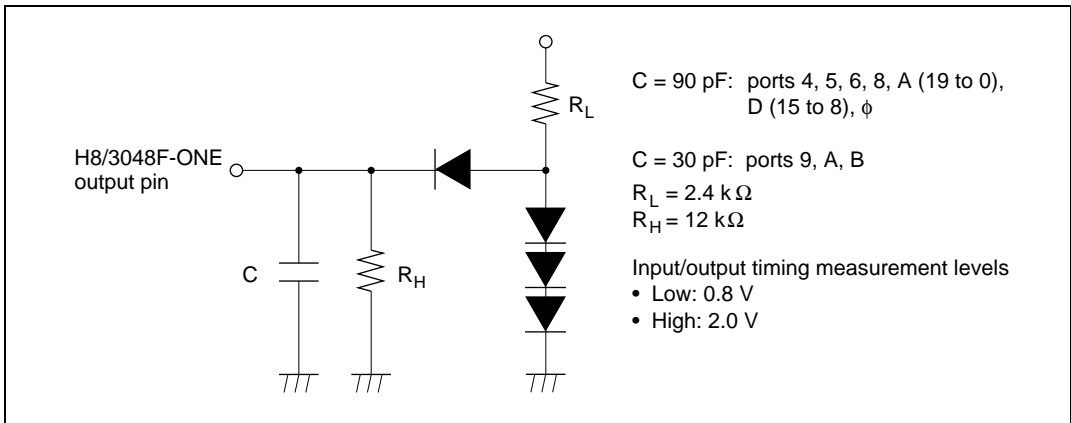

Figure 21.3 Output Load Circuit

21.1.4 A/D Conversion Characteristics

Table 21.9 lists the A/D conversion characteristics.

Table 21.9 A/D Converter Characteristics

Condition A: $V_{CC} = 3.0\text{ V to }3.6\text{ V}$, $AV_{CC} = 3.0\text{ V to }3.6\text{ V}$, $V_{REF} = 3.0\text{ V to }AV_{CC}$,
 $V_{SS} = AV_{SS} = 0\text{ V}$, $\phi = 2\text{ MHz to }25\text{ MHz}$, $T_a = -20^\circ\text{C to }+75^\circ\text{C}$ (regular specifications), $T_a = -40^\circ\text{C to }+85^\circ\text{C}$ (wide-range specifications)

Condition B: $V_{CC} = 5.0\text{ V} \pm 10\%$, $AV_{CC} = 5.0\text{ V} \pm 10\%$, $V_{REF} = 4.5\text{ V to }AV_{CC}$,
 $V_{SS} = AV_{SS} = 0\text{ V}$, $\phi = 2\text{ MHz to }25\text{ MHz}$, $T_a = -20^\circ\text{C to }+75^\circ\text{C}$ (regular specifications), $T_a = -40^\circ\text{C to }+85^\circ\text{C}$ (wide-range specifications)

Item	Condition A			Condition B			Unit	
	25 MHz			25 MHz				
	Min	Typ	Max	Min	Typ	Max		
Resolution	10	10	10	10	10	10	bits	
Conversion time (single mode)	5.36	—	—	5.36	—	—	μs	
Analog input capacitance	—	—	20	—	—	20	pF	
Permissible signal-source impedance	$\phi \leq 13\text{ MHz}$	—	—	10	—	—	10	k Ω
	$\phi > 13\text{ MHz}$	—	—	5	—	—	5	
Nonlinearity error	—	—	± 3.5	—	—	± 3.5	LSB	
Offset error	—	—	± 3.5	—	—	± 3.5	LSB	
Full-scale error	—	—	± 3.5	—	—	± 3.5	LSB	
Quantization error	—	—	± 0.5	—	—	± 0.5	LSB	
Absolute accuracy	—	—	± 4.0	—	—	± 4.0	LSB	

21.1.5 D/A Conversion Characteristics

Table 21.10 lists the D/A conversion characteristics.

Table 21.10 D/A Converter Characteristics

Condition A: $V_{CC} = 3.0\text{ V to }3.6\text{ V}$, $AV_{CC} = 3.0\text{ V to }3.6\text{ V}$, $V_{REF} = 3.0\text{ V to }AV_{CC}$,
 $V_{SS} = AV_{SS} = 0\text{ V}$, $\phi = 2\text{ MHz to }25\text{ MHz}$, $T_a = -20^\circ\text{C to }+75^\circ\text{C}$ (regular specifications), $T_a = -40^\circ\text{C to }+85^\circ\text{C}$ (wide-range specifications)

Condition B: $V_{CC} = 5.0\text{ V } \pm 10\%$, $AV_{CC} = 5.0\text{ V } \pm 10\%$, $V_{REF} = 4.5\text{ V to }AV_{CC}$,
 $V_{SS} = AV_{SS} = 0\text{ V}$, $\phi = 2\text{ MHz to }25\text{ MHz}$, $T_a = -20^\circ\text{C to }+75^\circ\text{C}$ (regular specifications), $T_a = -40^\circ\text{C to }+85^\circ\text{C}$ (wide-range specifications)

Item	Condition A			Condition B			Unit	Test Conditions
	25 MHz			25 MHz				
	Min	Typ	Max	Min	Typ	Max		
Resolution	8	8	8	8	8	8	bits	
Conversion time (centering time)	—	—	10	—	—	10	μs	20-pF capacitive load
Absolute accuracy	—	± 2.0	± 3.0	—	± 1.5	± 2.0	LSB	2-M Ω resistive load
	—	—	± 2.0	—	—	± 1.5	LSB	4-M Ω resistive load

21.1.6 Flash Memory Characteristics

Table 21.11 lists the flash memory characteristics.

Table 21.11 Flash Memory Characteristics (1)

Conditions: $V_{CC} = 4.5\text{ V to }5.5\text{ V}$, $AV_{CC} = 4.5\text{ V to }5.5\text{ V}$, $V_{REF} = 4.5\text{ V to }AV_{CC}$, $V_{SS} = AV_{SS} = 0\text{ V}$,
 $T_a = 0^\circ\text{C to }+75^\circ\text{C}$ (program/erase operating temperature range)

Item	Symbol	Min	Typ	Max	Unit	Notes		
Programming time ^{*1 *2 *4}	t_p	—	10	200	ms/ 128 bytes			
Erase time ^{*1 *3 *5}	t_E	—	100	1200	ms/block			
Reprogramming count	N_{WEC}	—	—	100	Times			
Programming	Wait time after SWE bit setting ^{*1}	t_{sswe}	1	1	—	μs		
	Wait time after PSU bit setting ^{*1}	t_{spsu}	50	50	—	μs		
	Wait time after P bit setting ^{*1 *4}	t_{sp30}	28	30	32	μs	Programming time wait	
		t_{sp200}	198	200	202	μs	Programming time wait	
		t_{sp10}	8	10	12	μs	Additional programming time wait	
	Wait time after P bit clear ^{*1}	t_{cp}	5	5	—	μs		
	Wait time after PSU bit clear ^{*1}	t_{cpsu}	5	5	—	μs		
	Wait time after PV bit setting ^{*1}	t_{spv}	4	4	—	μs		
	Wait time after H'FF dummy write ^{*1}	t_{spvr}	2	2	—	μs		
	Wait time after PV bit clear ^{*1}	t_{cpv}	2	2	—	μs		
	Wait time after SWE bit clear ^{*1}	t_{cswe}	100	100	—	μs		
	Maximum programming count ^{*1 *4}	N	—	—	1000	Times		
	Erase	Wait time after SWE bit setting ^{*1}	t_{sswe}	1	1	—	μs	
		Wait time after ESU bit setting ^{*1}	t_{sesu}	100	100	—	μs	
Wait time after E bit setting ^{*1 *5}		t_{se}	10	10	100	ms	Erase time wait	
Wait time after E bit clear ^{*1}		t_{ce}	10	10	—	μs		
Wait time after ESU bit clear ^{*1}		t_{cesu}	10	10	—	μs		
Wait time after EV bit setting ^{*1}		t_{sev}	20	20	—	μs		
Wait time after H'FF dummy write ^{*1}		t_{sevr}	2	2	—	μs		
Wait time after EV bit clear ^{*1}		t_{cev}	4	4	—	μs		
Wait time after SWE bit clear ^{*1}		t_{cswe}	100	100	—	μs		
Maximum erase count ^{*1 *5}	N	12	—	120	Times			

- Notes:
1. Set the times according to the program/erase algorithms.
 2. Programming time per 128 bytes. (Shows the total time the P bit in the flash memory control register (FLMCR1) is set. It does not include the programming verification time.)
 3. Block erase time. (Shows the total time the E bit in FLMCR1 is set. It does not include the erase verification time.)
 4. To specify the maximum programming time value ($t_p(\max)$) in the 128-byte programming algorithm, set the max. value (1000) for the maximum programming count (N).

The wait time after P bit setting should be changed as follows according to the value of the programming counter (n).

Programming counter (n) = 1 to 6: $t_{sp30} = 30 \mu\text{s}$

Programming counter (n) = 7 to 1000: $t_{sp200} = 200 \mu\text{s}$

Programming counter (n) [in additional programming] = 1 to 6: $t_{sp10} = 10 \mu\text{s}$

5. For the maximum erase time ($t_E(\max)$), the following relationship applies between the wait time after E bit setting (t_{se}) and the maximum erase count (N):

$t_E(\max) = \text{Wait time after E bit setting } (t_{se}) \times \text{maximum erase count } (N)$

To set the maximum erase time, the values of t_{se} and N should be set so as to satisfy the above formula.

Examples: When $t_{se} = 100 \text{ [ms]}$, $N = 12$

When $t_{se} = 10 \text{ [ms]}$, $N = 120$

Table 21.11 Flash Memory Characteristics (2)

Conditions: $V_{CC} = 3.0$ to 3.6 V, $AV_{CC} = 3.0$ to 3.6 V, $V_{REF} = 3.0$ V to AV_{CC} , $V_{SS} = AV_{SS} = 0$ V,
 $T_a = 0^{\circ}\text{C}$ to $+75^{\circ}\text{C}$ (operating temperature range for programming/erasing)

Item	Symbol	Min	Typ	Max	Unit	Notes	
Programming time ^{*1 *2 *4}	t_p	—	10	200	ms/ 128 bytes		
Erase time ^{*1 *3 *5}	t_E	—	100	1200	ms/block		
Reprogramming count	N_{WEC}	—	—	100	Times		
Programming	Wait time after SWE bit setting ^{*1}	t_{sswe}	1	1	—	μs	
	Wait time after PSU bit setting ^{*1}	t_{spsu}	50	50	—	μs	
	Wait time after P bit setting ^{*1 *4}	t_{sp30}	28	30	32	μs	Programming time wait
		t_{sp200}	198	200	202	μs	Programming time wait
		t_{sp10}	8	10	12	μs	Additional- programming time wait
	Wait time after P bit clear ^{*1}	t_{cp}	5	5	—	μs	
	Wait time after PSU bit clear ^{*1}	t_{cpsu}	5	5	—	μs	
	Wait time after PV bit setting ^{*1}	t_{spv}	4	4	—	μs	
	Wait time after H'FF dummy write ^{*1}	t_{spvr}	2	2	—	μs	
	Wait time after PV bit clear ^{*1}	t_{cpv}	2	2	—	μs	
	Wait time after SWE bit clear ^{*1}	t_{cswe}	100	100	—	μs	
	Maximum programming count ^{*1 *4}	N	—	—	1000	Times	
	Erase	Wait time after SWE bit setting ^{*1}	t_{sswe}	1	1	—	μs
Wait time after ESU bit setting ^{*1}		t_{sesu}	100	100	—	μs	
Wait time after E bit setting ^{*1 *5}		t_{se}	10	10	100	ms	Erase time wait
Wait time after E bit clear ^{*1}		t_{ce}	10	10	—	μs	
Wait time after ESU bit clear ^{*1}		t_{cesu}	10	10	—	μs	
Wait time after EV bit setting ^{*1}		t_{sev}	20	20	—	μs	
Wait time after H'FF dummy write ^{*1}		t_{sevr}	2	2	—	μs	
Wait time after EV bit clear ^{*1}		t_{cev}	4	4	—	μs	
Wait time after SWE bit clear ^{*1}		t_{cswe}	100	100	—	μs	
Maximum erase count ^{*1 *5}	N	12	—	120	Times		

- Notes: 1. Make each time setting in accordance with the program/program-verify flowchart or erase/erase-verify flowchart.
2. Programming time per 128 bytes (Shows the total period for which the P bit in the flash memory control register 1 (FLMCR1) is set. It does not include the programming verification time.)
3. Block erase time (Shows the total period for which the E bit in FLMCR1 is set. It does not include the erase verification time.)
4. To specify the maximum programming time ($t_p(\max)$) in the 128-byte programming flowchart, set the maximum value (1000) for the maximum programming count (N).
The wait time after P bit setting should be changed as follows according to the value of the programming counter (n).

Programming counter (n) = 1 to 6: $t_{sp30} = 30 \mu\text{s}$

Programming counter (n) = 7 to 1000: $t_{sp200} = 200 \mu\text{s}$

Programming counter (n) [in additional programming] = 1 to 6: $t_{sp10} = 10 \mu\text{s}$

5. For the maximum erase time ($t_E(\max)$), the following relationship applies between the wait time after E bit setting (t_{se}) and the maximum erase count (N):

$$t_E(\max) = \text{Wait time after E bit setting } (t_{se}) \times \text{maximum erase count } (N)$$

To set the maximum erase time, the values of t_{se} and N should be set so as to satisfy the above formula.

Examples: When $t_{se} = 100$ [ms], N = 12 times

When $t_{se} = 10$ [ms], N = 120 times

21.2 Electrical Characteristics of H8/3048B (Mask ROM)

21.2.1 Absolute Maximum Ratings

Table 21.12 lists the absolute maximum ratings.

Table 21.12 Absolute Maximum Ratings

Item	Symbol	Value	Unit
Power supply voltage	V_{CC}^{*1}	5 V operation model: -0.3 to +7.0	V
		3 V operation model: -0.3 to +4.6	
Input voltage (FWE) ^{*2}	V_{in}	-0.3 to $V_{CC} + 0.3$	V
Input voltage (except for port 7) ^{*2}	V_{in}	-0.3 to $V_{CC} + 0.3$	V
Input voltage (port 7)	V_{in}	-0.3 to $AV_{CC} + 0.3$	V
Reference voltage	V_{REF}	-0.3 to $AV_{CC} + 0.3$	V
Analog power supply voltage	AV_{CC}	5 V operation model: -0.3 to +7.0	V
		3 V operation model: -0.3 to +4.6	
Analog input voltage	V_{AN}	-0.3 to $AV_{CC} + 0.3$	V
Operating temperature	T_{opr}	Regular specifications: -20 to +75 ^{*3}	°C
		Wide-range specifications: -40 to +85 ^{*3}	
Storage temperature	T_{stg}	-55 to +125	°C

Caution: Permanent damage to the chip may result if absolute maximum ratings are exceeded.

- Notes:
1. Do not apply the power supply voltage to the V_{CL} pin in 5 V operation models. Connect an external capacitor between this pin and GND.
 2. 12 V must not be applied to any pin, as this may cause permanent damage to the device.
 3. The operating temperature range for flash memory programming/erasing is 0°C to +75°C.

21.2.2 DC Characteristics

Table 21.13 lists the DC characteristics. Table 21.14 lists the permissible output currents.

Table 21.13 DC Characteristics (1)

Conditions: $V_{CC} = 5.0\text{ V} \pm 10\%$, $AV_{CC} = 5.0\text{ V} \pm 10\%$, $V_{REF} = 4.5\text{ V}$ to AV_{CC} ,
 $V_{SS} = AV_{SS} = 0\text{ V}^{*1}$, $T_a = -20^\circ\text{C}$ to $+75^\circ\text{C}$ (regular specifications), $T_a = -40^\circ\text{C}$ to
 $+85^\circ\text{C}$ (wide-range specifications)

Item	Symbol	Min	Typ	Max	Unit	Test Conditions	
Schmitt trigger input voltages	Port A, PB_2 to PB_{07} , PB_3 to PB_0	V_T^-	1.0	—	—	V	
		V_T^+	—	—	$V_{CC} \times 0.7$	V	
		$V_T^+ - V_T^-$	0.4	—	—	V	
Input high voltage	\overline{RES} , \overline{STBY} , NMI , MD_2 to MD_0	V_{IH}	$V_{CC} - 0.7$	—	$V_{CC} + 0.3$	V	
	\overline{EXTAL}		$V_{CC} \times 0.7$	—	$V_{CC} + 0.3$	V	
	Port 7		2.0	—	$AV_{CC} + 0.3$	V	
	Ports 1 to 6, 9, PB_4 , PB_3 , PB_7 to PB_4		2.0	—	$V_{CC} + 0.3$	V	
Input low voltage	\overline{RES} , \overline{STBY} , MD_2 to MD_0	V_{IL}	-0.3	—	0.5	V	
	NMI , \overline{EXTAL} , ports 1 to 7, 9, PB_4 , PB_3 , PB_7 to PB_4		-0.3	—	0.8	V	
Output high voltage	All output pins (Except \overline{RESO})	V_{OH}	$V_{CC} - 0.5$	—	—	V	$I_{OH} = -200\ \mu\text{A}$
			3.5	—	—	V	$I_{OH} = -1\ \text{mA}$
Output low voltage	All output pins (Except \overline{RESO})	V_{OL}	—	—	0.4	V	$I_{OL} = 1.6\ \text{mA}$
			—	—	1.0	V	$I_{OL} = 10\ \text{mA}$
			—	—	0.4		$I_{OL} = 1.6\ \text{mA}$
Input leakage current	\overline{STBY} , NMI , \overline{RES} , MD_2 to MD_0	$ I_{in} $	—	—	1.0	μA	$V_{in} = 0.5$ to $V_{CC} - 0.5\ \text{V}$
	Port 7		—	—	1.0	μA	$V_{in} = 0.5$ to $AV_{CC} - 0.5\ \text{V}$

Item		Symbol	Min	Typ	Max	Unit	Test Conditions
Three-state leakage current (off state)	Ports 1 to 6, 8 to B	$ I_{TSL} $	—	—	1.0	μA	$V_{in} = 0.5$ to $V_{CC} - 0.5$ V
Input pull-up MOS current	Ports 2, 4, and 5	$-I_p$	50	—	300	μA	$V_{in} = 0$ V
Input capacitance	NMI	C_{in}	—	—	50	pF	$V_{in} = 0$ V,
	All input pins except NMI		—	—	15	pF	$f = f_{min}$, $T_a = 25^\circ\text{C}$
Current dissipation ^{*2}	Normal operation	I_{CC}^{*5}	—	45	60	mA	$f = 25$ MHz
	Sleep mode		—	35	50	mA	
	Module standby mode ^{*4}		—	20	25	mA	
	Standby mode ^{*3}			—	1	10	μA
			—	—	80	μA	$50^\circ\text{C} < T_a$
Analog power supply current	During A/D conversion	AI_{CC}	—	0.5	1.5	mA	$AV_{CC} = 5.0$ V
	During A/D and D/A conversion		—	0.5	1.5	mA	
	Idle		—	0.01	5.0	μA	DASTE = 0
Reference current	During A/D conversion	AI_{CC}	—	0.4	0.8	mA	$V_{REF} = 5.0$ V
	During A/D and D/A conversion		—	1.5	3.0	mA	
	Idle		—	0.01	5.0	μA	DASTE = 0
RAM standby voltage		V_{RAM}	2.0	—	—	V	

Notes: 1. If the A/D and D/A converters are not used, do not leave the AV_{CC} , AV_{SS} , and V_{REF} pins open. Connect AV_{CC} and V_{REF} to V_{CC} , and connect AV_{SS} to V_{SS} .

2. Current dissipation values are for $V_{IH} \text{ min} = V_{CC} - 0.5$ V and $V_{IL} \text{ max} = 0.5$ V with all output pins unloaded and the on-chip pull-up transistors in the off state.

3. The values are for $V_{RAM} \leq V_{CC} < 4.5$ V, $V_{IH} \text{ min} = V_{CC} \times 0.9$, and $V_{IL} \text{ max} = 0.3$ V.

4. Module standby current values apply in sleep mode with all modules halted.

5. I_{CC} depends on V_{CC} and f , according to the following expressions.

[Applicable operating frequency: 2 to 25 MHz]

$I_{CC} \text{ max. (normal operation)} = 5.0$ [mA] + 0.32 [mA/(MHz \times V)] $\times V_{CC} \times (f - 2)$

$I_{CC} \text{ max. (sleep mode)} = 7.0$ [mA] + 0.26 [mA/(MHz \times V)] $\times V_{CC} \times (f - 2)$

$I_{CC} \text{ max. (sleep mode and module standby mode)} = 6.0$ [mA] + 0.11 [mA/(MHz \times V)] $\times V_{CC} \times (f - 2)$

The typical values of current dissipation are reference values.

Table 21.13 DC Characteristics (2)

Conditions: $V_{CC} = 3.0\text{ V to }3.6\text{ V}$, $AV_{CC} = 3.0\text{ V to }3.6\text{ V}$, $V_{REF} = 3.0\text{ V to }AV_{CC}$,
 $V_{SS} = AV_{SS} = 0\text{ V}^{*1}$, $T_a = -20^\circ\text{C to }+75^\circ\text{C}$ (regular specifications), $T_a = -40^\circ\text{C to }+85^\circ\text{C}$ (wide-range specifications)

Item	Symbol	Min	Typ	Max	Unit	Test Conditions		
Schmitt trigger input voltages	Port A, P8 ₂ to P8 ₀ , PB ₃ to PB ₀	V_T^-	$V_{CC} \times 0.2$	—	—	V		
		V_T^+	—	—	$V_{CC} \times 0.7$	V		
		$V_T^+ - V_T^-$	$V_{CC} \times 0.05$	—	—	V		
Input high voltage	RES, STBY, NMI, MD ₂ to MD ₀	V_{IH}	$V_{CC} \times 0.9$	—	$V_{CC} + 0.3$	V		
	EXTAL		$V_{CC} \times 0.7$	—	$V_{CC} + 0.3$	V		
	Port 7		$V_{CC} \times 0.7$	—	$AV_{CC} + 0.3$	V		
	Ports 1 to 6, 9, P8 ₄ , P8 ₃ , PB ₇ to PB ₄		$V_{CC} \times 0.7$	—	$V_{CC} + 0.3$	V		
Input low voltage	RES, STBY, MD ₂ to MD ₀	V_{IL}	-0.3	—	$V_{CC} \times 0.1$	V		
	NMI, EXTAL, ports 1 to 7, 9, P8 ₄ , P8 ₃ , PB ₇ to PB ₄		-0.3	—	$V_{CC} \times 0.2$	V		
Output high voltage	All output pins (Except RES0)	V_{OH}	$V_{CC} - 0.5$	—	—	V	$I_{OH} = -200\ \mu\text{A}$	
			$V_{CC} - 1.0$	—	—	V	$I_{OH} = -1\ \text{mA}$	
Output low voltage	All output pins (Except RES0)	V_{OL}	—	—	0.4	V	$I_{OL} = 1.6\ \text{mA}$	
			Ports 1, 2, 5, and B	—	—	1.0	V	$I_{OL} = 5\ \text{mA}$
			RES0	—	—	0.4	V	$I_{OL} = 1.6\ \text{mA}$
Input leakage current	STBY, NMI, RES, MD ₂ to MD ₀	$ I_{in} $	—	—	1.0	μA	$V_{in} = 0.5\text{ to }V_{CC} - 0.5\text{ V}$	
	Port 7		—	—	1.0	μA	$V_{in} = 0.5\text{ to }AV_{CC} - 0.5\text{ V}$	

Item		Symbol	Min	Typ	Max	Unit	Test Conditions
Three-state leakage current (off state)	Ports 1 to 6, 8 to B	$ I_{TSL} $	—	—	1.0	μA	$V_{in} = 0.5$ to $V_{CC} - 0.5$ V
Input pull-up MOS current	Ports 2, 4, and 5	$-I_p$	10	—	300	μA	$V_{in} = 0$ V
Input capacitance	NMI	C_{in}	—	—	50	pF	$V_{in} = 0$ V,
	All input pins except NMI		—	—	15	pF	$f = f_{min}$, $T_a = 25^\circ\text{C}$
Current dissipation*2	Normal operation	I_{CC}^{*5}	—	40	50	mA	$f = 25$ MHz
	Sleep mode		—	25	40	mA	
	Module standby mode*4		—	15	20	mA	
	Standby mode*3			—	1	10	μA
			—	—	80	μA	$50^\circ\text{C} < T_a$
Analog power supply current	During A/D conversion	AI_{CC}	—	0.5	1.5	mA	$AV_{CC} = 3.3$ V
	During A/D and D/A conversion		—	0.5	1.5	mA	
	Idle		—	0.01	5	μA	DASTE = 0
Reference current	During A/D conversion	AI_{CC}	—	0.4	0.8	mA	$V_{REF} = 3.3$ V
	During A/D and D/A conversion		—	1.5	3	mA	
	Idle		—	0.01	5	μA	DASTE = 0
RAM standby voltage		V_{RAM}	2.0	—	—	V	

- Notes: 1. If the A/D and D/A converters are not used, do not leave the AV_{CC} , AV_{SS} , and V_{REF} pins open. Connect AV_{CC} and V_{REF} to V_{CC} , and connect AV_{SS} to V_{SS} .
2. Current dissipation values are for V_{IH} min = $V_{CC} - 0.5$ V and V_{IL} max = 0.5 V with all output pins unloaded and the on-chip pull-up transistors in the off state.
3. The values are for $V_{RAM} \leq V_{CC} < 3.0$ V, V_{IH} min = $V_{CC} \times 0.9$, and V_{IL} max = 0.3 V.
4. Module standby current values apply in sleep mode with all modules halted.
5. I_{CC} depends on V_{CC} and f , according to the following expressions.
 [Applicable operating frequency: 2 to 25 MHz]
 I_{CC} max. (normal operation) = 6.0 [mA] + 0.53 [mA/(MHz \times V)] $\times V_{CC} \times (f - 2)$
 I_{CC} max. (sleep mode) = 4.0 [mA] + 0.43 [mA/(MHz \times V)] $\times V_{CC} \times (f - 2)$
 I_{CC} max. (sleep mode and module standby mode) = 3.0 [mA] + 0.20 [mA/(MHz \times V)] $\times V_{CC} \times (f - 2)$
 The typical values of current dissipation are reference values.

Table 21.14 Permissible Output Currents

Condition A: $V_{CC} = 3.0\text{ V to }3.6\text{ V}$, $AV_{CC} = 3.0\text{ V to }3.6\text{ V}$, $V_{REF} = 3.0\text{ V to }AV_{CC}$,
 $V_{SS} = AV_{SS} = 0\text{ V}$, $T_a = -20^\circ\text{C to }+75^\circ\text{C}$ (regular specifications), $T_a = -40^\circ\text{C to }+85^\circ\text{C}$ (wide-range specifications)

Condition B: $V_{CC} = 5.0\text{ V} \pm 10\%$, $AV_{CC} = 5.0\text{ V} \pm 10\%$, $V_{REF} = 4.5\text{ V to }AV_{CC}$,
 $V_{SS} = AV_{SS} = 0\text{ V}$, $T_a = -20^\circ\text{C to }+75^\circ\text{C}$ (regular specifications), $T_a = -40^\circ\text{C to }+85^\circ\text{C}$ (wide-range specifications)

Item	Symbol	Conditions A, B			Unit	
		Min	Typ	Max		
Permissible output low current (per pin)	Ports 1, 2, 5, and B	I_{OL}	—	—	10	mA
	Other output pins		—	—	2.0	mA
Permissible output low current (total)	Total of 28 pins in ports 1, 2, 5, and B	ΣI_{OL}	—	—	80	mA
	Total of all output pins, including the above		—	—	120	mA
Permissible output high current (per pin)	All output pins	I_{OH}	—	—	2.0	mA
Permissible output high current (total)	Total of all output pins	ΣI_{OH}	—	—	40	mA

- Notes: 1. To protect chip reliability, do not exceed the output current values in table 21.14.
 2. When driving a darlington pair or LED, always insert a current-limiting resistor in the output line, as shown in figures 21.4 and 21.5.

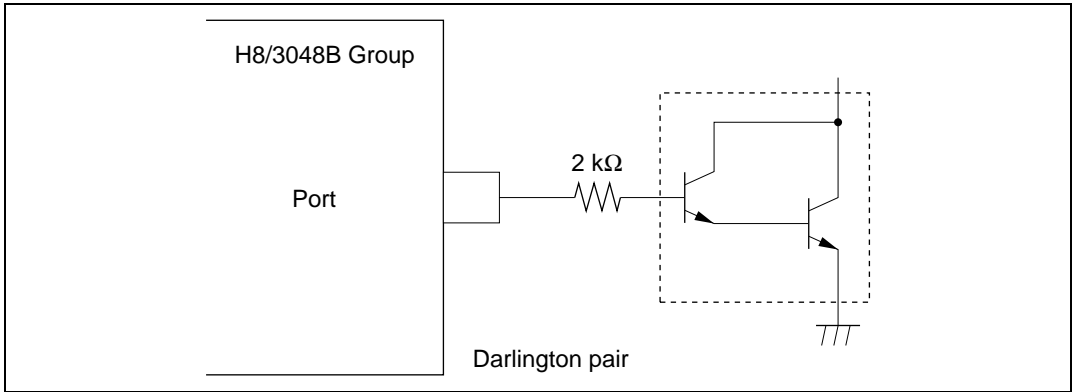
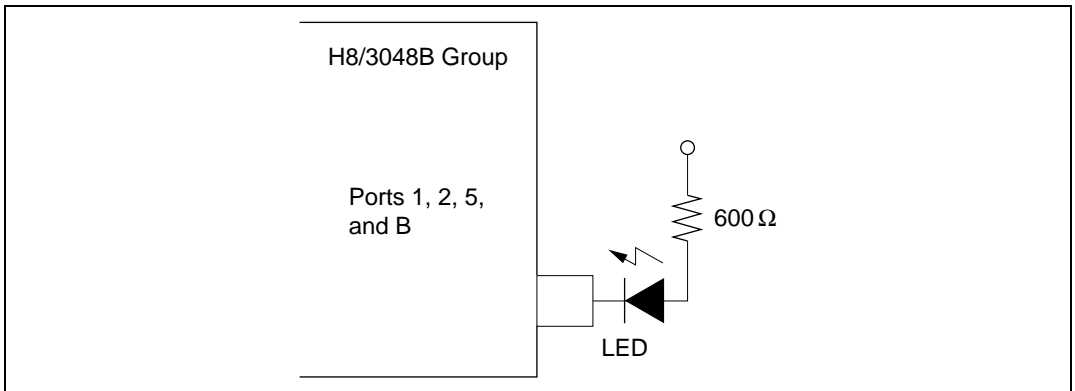
**Figure 21.4 Darlington Pair Drive Circuit (Example)****Figure 21.5 LED Drive Circuit (Example)**

21.2.3 AC Characteristics

Bus timing parameters are listed in table 21.15. Refresh controller bus timing parameters are listed in table 21.16. Control signal timing parameters are listed in table 21.17. Timing parameters of the on-chip supporting modules are listed in table 21.18.

Table 21.15 Bus Timing

Condition A: $V_{CC} = 3.0\text{ V to }3.6\text{ V}$, $AV_{CC} = 3.0\text{ V to }3.6\text{ V}$, $V_{REF} = 3.0\text{ V to }AV_{CC}$,
 $V_{SS} = AV_{SS} = 0\text{ V}$, $\phi = 2\text{ MHz to }25\text{ MHz}$, $T_a = -20^\circ\text{C to }+75^\circ\text{C}$ (regular specifications), $T_a = -40^\circ\text{C to }+85^\circ\text{C}$ (wide-range specifications)

Condition B: $V_{CC} = 5.0\text{ V} \pm 10\%$, $AV_{CC} = 5.0\text{ V} \pm 10\%$, $V_{REF} = 4.5\text{ V to }AV_{CC}$,
 $V_{SS} = AV_{SS} = 0\text{ V}$, $\phi = 2\text{ MHz to }25\text{ MHz}$, $T_a = -20^\circ\text{C to }+75^\circ\text{C}$ (regular specifications), $T_a = -40^\circ\text{C to }+85^\circ\text{C}$ (wide-range specifications)

Item	Symbol	Condition A		Condition B		Unit	Test Conditions
		25 MHz		25 MHz			
		Min	Max	Min	Max		
Clock cycle time	t_{cyc}	40	500	40	500	ns	Figure 21.7
Clock pulse low width	t_{CL}	10	—	10	—		Figure 21.8
Clock pulse high width	t_{CH}	10	—	10	—		
Clock rise time	t_{CR}	—	10	—	10		
Clock fall time	t_{CF}	—	10	—	10		
Address delay time	t_{AD}	—	28	—	25		
Address hold time	t_{AH}	$0.5t_{cyc} - 20$	—	$0.5t_{cyc} - 20$	—		
Address strobe delay time	t_{ASD}	—	25	—	25		
Write strobe delay time	t_{WSD}	—	25	—	25		
Strobe delay time	t_{SD}	—	25	—	25		
Write data strobe pulse width 1	t_{WSW1}	$1.0t_{cyc} - 25$	—	$1.0t_{cyc} - 25$	—		
Write data strobe pulse width 2	t_{WSW2}	$1.5t_{cyc} - 25$	—	$1.5t_{cyc} - 25$	—		
Address setup time 1	t_{AS1}	$0.5t_{cyc} - 20$	—	$0.5t_{cyc} - 20$	—		
Address setup time 2	t_{AS2}	$1.0t_{cyc} - 20$	—	$1.0t_{cyc} - 20$	—		
Read data setup time	t_{RDS}	15	—	15	—		
Read data hold time	t_{RDH}	0	—	0	—		

Item	Symbol	Condition A		Condition B		Unit	Test Conditions
		25 MHz		25 MHz			
		Min	Max	Min	Max		
Write data delay time	t_{WDD}	—	35	—	35	ns	Figure 21.7
Write data setup time 1	t_{WDS1}	$1.0t_{\text{cyc}} - 30$	—	$1.0t_{\text{cyc}} - 30$	—		Figure 21.8
Write data setup time 2	t_{WDS2}	$0.5t_{\text{cyc}} - 30$	—	$0.5t_{\text{cyc}} - 30$	—		
Write data hold time	t_{WDH}	$0.5t_{\text{cyc}} - 15$	—	$0.5t_{\text{cyc}} - 15$	—		
Read data access time 1	t_{ACC1}	—	$1.5t_{\text{cyc}} - 40$	—	$1.5t_{\text{cyc}} - 40$		
Read data access time 2	t_{ACC2}	—	$2.5t_{\text{cyc}} - 40$	—	$2.5t_{\text{cyc}} - 40$		
Read data access time 3	t_{ACC3}	—	$1.0t_{\text{cyc}} - 28$	—	$1.0t_{\text{cyc}} - 28$		
Read data access time 4	t_{ACC4}	—	$2.0t_{\text{cyc}} - 32$	—	$2.0t_{\text{cyc}} - 32$		
Precharge time	t_{PCH}	$1.0t_{\text{cyc}} - 20$	—	$1.0t_{\text{cyc}} - 20$	—		
Wait setup time	t_{WTS}	25	—	25	—	ns	Figure 21.9
Wait hold time	t_{WTH}	5	—	5	—		
Bus request setup time	t_{BRQS}	25	—	25	—	ns	Figure 21.21
Bus acknowledge delay time 1	t_{BACD1}	—	30	—	30		
Bus acknowledge delay time 2	t_{BACD2}	—	30	—	30		
Bus-floating time	t_{BZD}	—	40	—	40		

Table 21.16 Refresh Controller Bus Timing

Condition A: $V_{CC} = 3.0\text{ V to }3.6\text{ V}$, $AV_{CC} = 3.0\text{ V to }3.6\text{ V}$, $V_{REF} = 3.0\text{ V to }AV_{CC}$,
 $V_{SS} = AV_{SS} = 0\text{ V}$, $\phi = 2\text{ MHz to }25\text{ MHz}$, $T_a = -20^\circ\text{C to }+75^\circ\text{C}$ (regular specifications), $T_a = -40^\circ\text{C to }+85^\circ\text{C}$ (wide-range specifications)

Condition B: $V_{CC} = 5.0\text{ V} \pm 10\%$, $AV_{CC} = 5.0\text{ V} \pm 10\%$, $V_{REF} = 4.5\text{ V to }AV_{CC}$,
 $V_{SS} = AV_{SS} = 0\text{ V}$, $\phi = 2\text{ MHz to }25\text{ MHz}$, $T_a = -20^\circ\text{C to }+75^\circ\text{C}$ (regular specifications), $T_a = -40^\circ\text{C to }+85^\circ\text{C}$ (wide-range specifications)

Item	Symbol	Condition A		Condition B		Unit	Test Conditions
		25 MHz		25 MHz			
		Min	Max	Min	Max		
$\overline{\text{RAS}}$ delay time 1 ^{*1}	t_{RAD1}	—	20	—	18	ns	Figure 21.10 to Figure 21.16
$\overline{\text{RAS}}$ delay time 2 ^{*1}	t_{RAD2}	—	20	—	18		
$\overline{\text{RAS}}$ delay time 3 ^{*1}	t_{RAD3}	—	20	—	18		
Row address hold time	t_{RAH}	$0.5t_{\text{cyc}} - 5$	—	$0.5t_{\text{cyc}} - 5$	—		
$\overline{\text{RAS}}$ precharge time ^{*1}	t_{RP}	$1.0t_{\text{cyc}} - 15$	—	$1.0t_{\text{cyc}} - 15$	—		
$\overline{\text{CAS}}$ to $\overline{\text{RAS}}$ precharge time ^{*1 *2}	t_{CRP}	$1.0t_{\text{cyc}} - 15$	—	$1.0t_{\text{cyc}} - 15$	—		
$\overline{\text{CAS}}$ pulse width ^{*2}	t_{CAS}	$1.0t_{\text{cyc}} - 18$	—	$1.0t_{\text{cyc}} - 18$	—		
$\overline{\text{RAS}}$ access time ^{*1}	t_{RAC}	—	$2.0t_{\text{cyc}} - 35$	—	$2.0t_{\text{cyc}} - 35$		
Address access time	t_{AA}	—	$1.5t_{\text{cyc}} - 40$	—	$1.5t_{\text{cyc}} - 40$		
$\overline{\text{CAS}}$ access time ^{*2}	t_{CAC}	—	$1.0t_{\text{cyc}} - 30$	—	$1.0t_{\text{cyc}} - 30$		
Write data setup time 3	t_{WDS3}	$1.0t_{\text{cyc}} - 25$	—	$1.0t_{\text{cyc}} - 25$	—		
$\overline{\text{CAS}}$ setup time ^{*2}	t_{CSR}	$0.5t_{\text{cyc}} - 15$	—	$0.5t_{\text{cyc}} - 15$	—		
Read strobe delay time	t_{RSD}	—	25	—	25		
Signal rise time (all input pins except EXTAL)	t_{SR}	—	100	—	100	ns	Figure 21.18
Signal fall time (all input pins except EXTAL)	t_{SF}	—	100	—	100		

Notes: 1. The $\overline{\text{RAS}}$ pin is assigned to the $\overline{\text{CS3}}$ pin.

2. The $\overline{\text{CAS}}$ pin is assigned to the $\overline{\text{RD}}$ pin.

Table 21.17 Control Signal Timing

Condition A: $V_{CC} = 3.0\text{ V to }3.6\text{ V}$, $AV_{CC} = 3.0\text{ V to }3.6\text{ V}$, $V_{REF} = 3.0\text{ V to }AV_{CC}$,
 $V_{SS} = AV_{SS} = 0\text{ V}$, $\phi = 2\text{ MHz to }25\text{ MHz}$, $T_a = -20^\circ\text{C to }+75^\circ\text{C}$ (regular specifications), $T_a = -40^\circ\text{C to }+85^\circ\text{C}$ (wide-range specifications)

Condition B: $V_{CC} = 5.0\text{ V} \pm 10\%$, $AV_{CC} = 5.0\text{ V} \pm 10\%$, $V_{REF} = 4.5\text{ V to }AV_{CC}$,
 $V_{SS} = AV_{SS} = 0\text{ V}$, $\phi = 2\text{ MHz to }25\text{ MHz}$, $T_a = -20^\circ\text{C to }+75^\circ\text{C}$ (regular specifications), $T_a = -40^\circ\text{C to }+85^\circ\text{C}$ (wide-range specifications)

Item	Symbol	Condition A		Condition B		Unit	Test Conditions
		25 MHz		25 MHz			
$\overline{\text{RES}}$ setup time	t_{RESS}	200	—	200	—	ns	Figure 21.18
$\overline{\text{RES}}$ pulse width	t_{RESW}	20	—	20	—	t_{cyc}	
Mode programming setup time	t_{MDS}	200	—	200	—	ns	
$\overline{\text{RESO}}$ output delay time	t_{RESO}	—	50	—	50	ns	Figure 21.19
$\overline{\text{RESO}}$ output pulse width	t_{RESOW}	132	—	132	—	t_{cyc}	
NMI setup time (NMI, $\overline{\text{IRQ}}_5$ to $\overline{\text{IRQ}}_0$)	t_{NMIS}	150	—	150	—	ns	Figure 21.20
NMI hold time (NMI, $\overline{\text{IRQ}}_5$ to $\overline{\text{IRQ}}_0$)	t_{NMIH}	10	—	10	—		
Interrupt pulse width (NMI, $\overline{\text{IRQ}}_2$ to $\overline{\text{IRQ}}_0$ when exiting software standby mode)	t_{NMIW}	200	—	200	—		
Clock oscillator settling time at reset (crystal)	t_{OSC1}	20	—	20	—	ms	Figure 21.22
Clock oscillator settling time in software standby (crystal)	t_{OSC2}	7	—	7	—	ms	Figure 20.1

Table 21.18 Timing of On-Chip Supporting Modules

Condition A: $V_{CC} = 3.0\text{ V to }3.6\text{ V}$, $AV_{CC} = 3.0\text{ V to }3.6\text{ V}$, $V_{REF} = 3.0\text{ V to }AV_{CC}$,
 $V_{SS} = AV_{SS} = 0\text{ V}$, $\phi = 2\text{ MHz to }25\text{ MHz}$, $T_a = -20^\circ\text{C to }+75^\circ\text{C}$ (regular specifications), $T_a = -40^\circ\text{C to }+85^\circ\text{C}$ (wide-range specifications)

Condition B: $V_{CC} = 5.0\text{ V} \pm 10\%$, $AV_{CC} = 5.0\text{ V} \pm 10\%$, $V_{REF} = 4.5\text{ V to }AV_{CC}$,
 $V_{SS} = AV_{SS} = 0\text{ V}$, $\phi = 2\text{ MHz to }25\text{ MHz}$, $T_a = -20^\circ\text{C to }+75^\circ\text{C}$ (regular specifications), $T_a = -40^\circ\text{C to }+85^\circ\text{C}$ (wide-range specifications)

Item	Symbol	Condition A		Condition B		Unit	Test Conditions		
		25 MHz		25 MHz					
DMAC	$\overline{\text{DREQ}}$ setup time	t_{DROs}	20	—	20	—	ns	Figure 21.30	
	$\overline{\text{DREQ}}$ hold time	t_{DROH}	10	—	10	—			
	$\overline{\text{TEND}}$ delay time 1	t_{TED1}	—	50	—	50		Figures 21.28 and 21.29	
	$\overline{\text{TEND}}$ delay time 2	t_{TED2}	—	50	—	50			
ITU	Timer output delay time	t_{TOCD}	—	50	—	50	ns	Figure 21.24	
	Timer input setup time	t_{TICS}	40	—	40	—		Figure 21.25	
	Timer clock input setup time	t_{TCKs}	40	—	40	—			
	Timer clock pulse width	Single edge Both edges	t_{TCKWH} t_{TCKWL}	1.5 2.5	— —	1.5 2.5	— —	t_{CYC}	
SCI	Input clock cycle	Asynchronous	t_{SCYC}	4	—	4	—	t_{CYC}	Figure 21.26
		Synchronous	t_{SCYC}	6	—	6	—		
	Input clock rise time	t_{SCKr}	—	1.5	—	1.5			
	Input clock fall time	t_{SCKf}	—	1.5	—	1.5			
	Input clock pulse width	t_{SCKW}	0.4	0.6	0.4	0.6	t_{SCYC}		
	Transmit data delay time	t_{TXD}	—	100	—	100	ns	Figure 21.27	
	Receive data setup time (synchronous)	t_{RXS}	100	—	100	—			
	Receive data hold time (synchronous)	Clock input	t_{RXH}	100	—	100	—		
Clock output		t_{RXH}	0	—	0	—			
Ports and TPC	Output data delay time	t_{PWD}	—	50	—	50	ns	Figure 21.23	
	Input data setup time	t_{PRS}	50	—	50	—			
	Input data hold time	t_{PRH}	50	—	50	—			

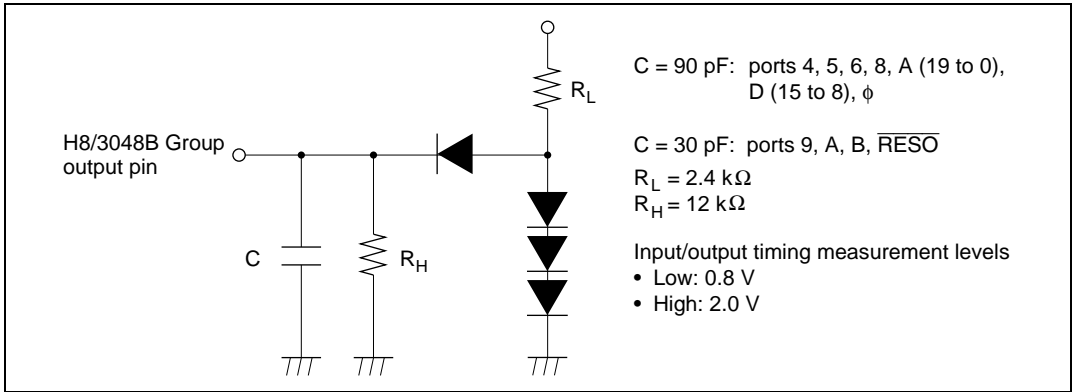

Figure 21.6 Output Load Circuit

21.2.4 A/D Conversion Characteristics

Table 21.19 lists the A/D conversion characteristics.

Table 21.19 A/D Converter Characteristics

Condition A: $V_{CC} = 3.0\text{ V to }3.6\text{ V}$, $AV_{CC} = 3.0\text{ V to }3.6\text{ V}$, $V_{REF} = 3.0\text{ V to }AV_{CC}$,
 $V_{SS} = AV_{SS} = 0\text{ V}$, $\phi = 2\text{ MHz to }25\text{ MHz}$, $T_a = -20^\circ\text{C to }+75^\circ\text{C}$ (regular
specifications), $T_a = -40^\circ\text{C to }+85^\circ\text{C}$ (wide-range specifications)

Condition B: $V_{CC} = 5.0\text{ V } \pm 10\%$, $AV_{CC} = 5.0\text{ V } \pm 10\%$, $V_{REF} = 4.5\text{ V to }AV_{CC}$,
 $V_{SS} = AV_{SS} = 0\text{ V}$, $\phi = 2\text{ MHz to }25\text{ MHz}$, $T_a = -20^\circ\text{C to }+75^\circ\text{C}$ (regular
specifications), $T_a = -40^\circ\text{C to }+85^\circ\text{C}$ (wide-range specifications)

Item	Condition A			Condition B			Unit
	25 MHz			25 MHz			
	Min	Typ	Max	Min	Typ	Max	
Resolution	10	10	10	10	10	10	bits
Conversion time (single mode)	5.36	—	—	5.36	—	—	μs
Analog input capacitance	—	—	20	—	—	20	pF
Permissible signal-source impedance	$\phi \leq 13\text{ MHz}$	—	10	—	—	10	k Ω
	$\phi > 13\text{ MHz}$	—	5	—	—	5	
Nonlinearity error	—	—	± 3.5	—	—	± 3.5	LSB
Offset error	—	—	± 3.5	—	—	± 3.5	LSB
Full-scale error	—	—	± 3.5	—	—	± 3.5	LSB
Quantization error	—	—	± 0.5	—	—	± 0.5	LSB
Absolute accuracy	—	—	± 4.0	—	—	± 4.0	LSB

21.2.5 D/A Conversion Characteristics

Table 21.20 lists the D/A conversion characteristics.

Table 21.20 D/A Converter Characteristics

Condition A: $V_{CC} = 3.0\text{ V to }3.6\text{ V}$, $AV_{CC} = 3.0\text{ V to }3.6\text{ V}$, $V_{REF} = 3.0\text{ V to }AV_{CC}$,
 $V_{SS} = AV_{SS} = 0\text{ V}$, $\phi = 2\text{ MHz to }25\text{ MHz}$, $T_a = -20^\circ\text{C to }+75^\circ\text{C}$ (regular
specifications), $T_a = -40^\circ\text{C to }+85^\circ\text{C}$ (wide-range specifications)

Condition B: $V_{CC} = 5.0\text{ V} \pm 10\%$, $AV_{CC} = 5.0\text{ V} \pm 10\%$, $V_{REF} = 4.5\text{ V to }AV_{CC}$,
 $V_{SS} = AV_{SS} = 0\text{ V}$, $\phi = 2\text{ MHz to }25\text{ MHz}$, $T_a = -20^\circ\text{C to }+75^\circ\text{C}$ (regular
specifications), $T_a = -40^\circ\text{C to }+85^\circ\text{C}$ (wide-range specifications)

Item	Condition A			Condition B			Unit	Test Conditions
	25 MHz			25 MHz				
	Min	Typ	Max	Min	Typ	Max		
Resolution	8	8	8	8	8	8	bits	
Conversion time (centering time)	—	—	10	—	—	10	μs	20-pF capacitive load
Absolute accuracy	—	± 2.0	± 3.0	—	± 1.5	± 2.0	LSB	2-M Ω resistive load
	—	—	± 2.0	—	—	± 1.5	LSB	4-M Ω resistive load

21.3 Operational Timing

This section shows timing diagrams.

21.3.1 Bus Timing

Bus timing is shown as follows:

- Basic bus cycle: two-state access
Figure 21.7 shows the timing of the external two-state access cycle.
- Basic bus cycle: three-state access
Figure 21.8 shows the timing of the external three-state access cycle.
- Basic bus cycle: three-state access with one wait state
Figure 21.9 shows the timing of the external three-state access cycle with one wait state inserted.

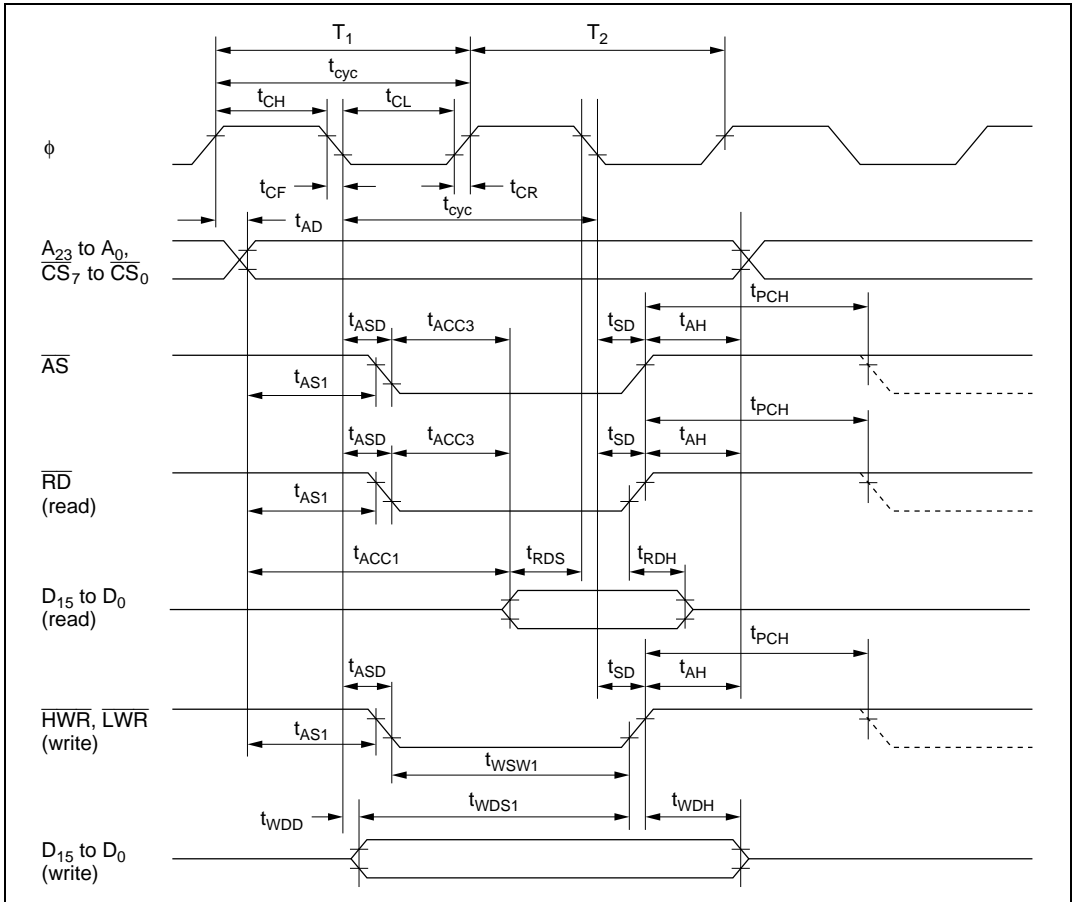

Figure 21.7 Basic Bus Cycle: Two-State Access

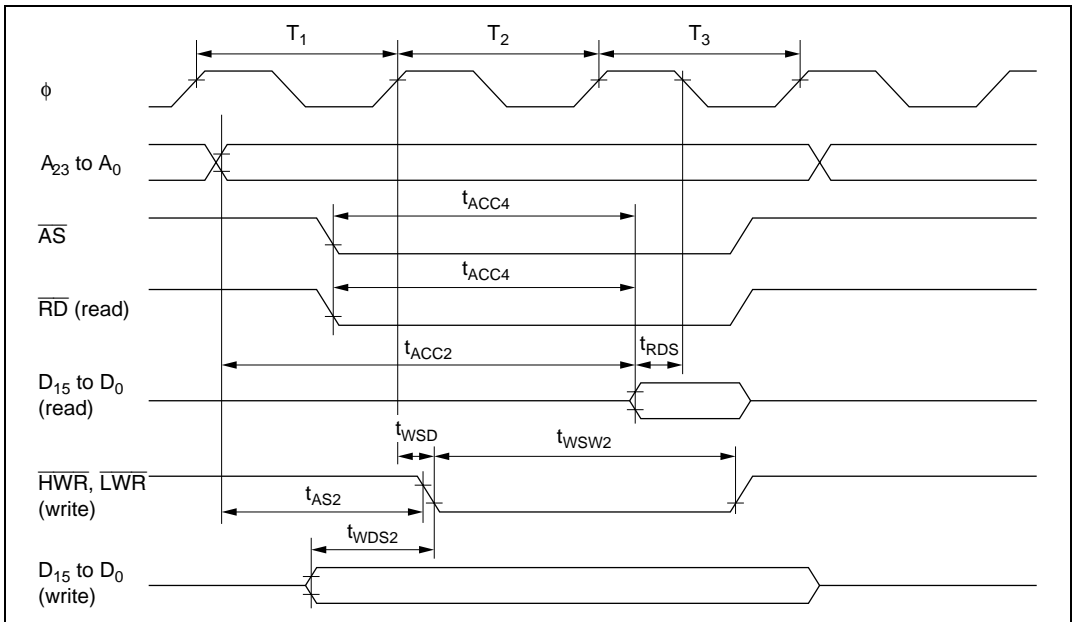

Figure 21.8 Basic Bus Cycle: Three-State Access

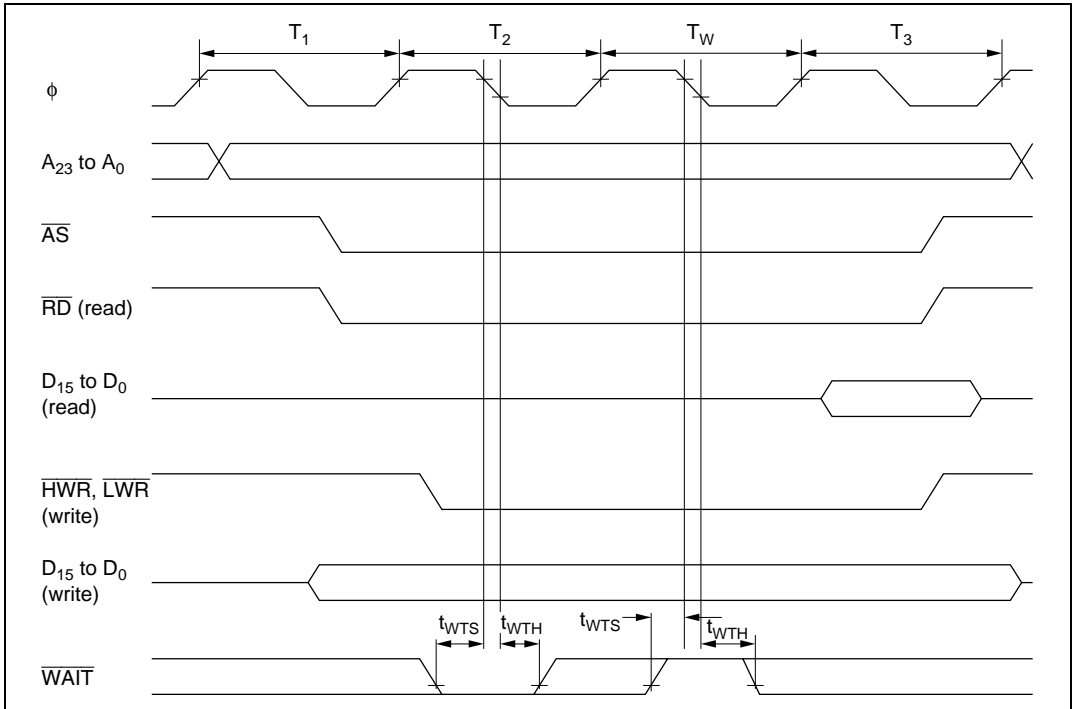

Figure 21.9 Basic Bus Cycle: Three-State Access with One Wait State

21.3.2 Refresh Controller Bus Timing

Refresh controller bus timing is shown as follows:

- DRAM bus timing
Figures 21.10 to 21.15 show the DRAM bus timing in each operating mode.
- PSRAM bus timing
Figures 21.16 and 21.17 show the pseudo-static RAM bus timing in each operating mode.

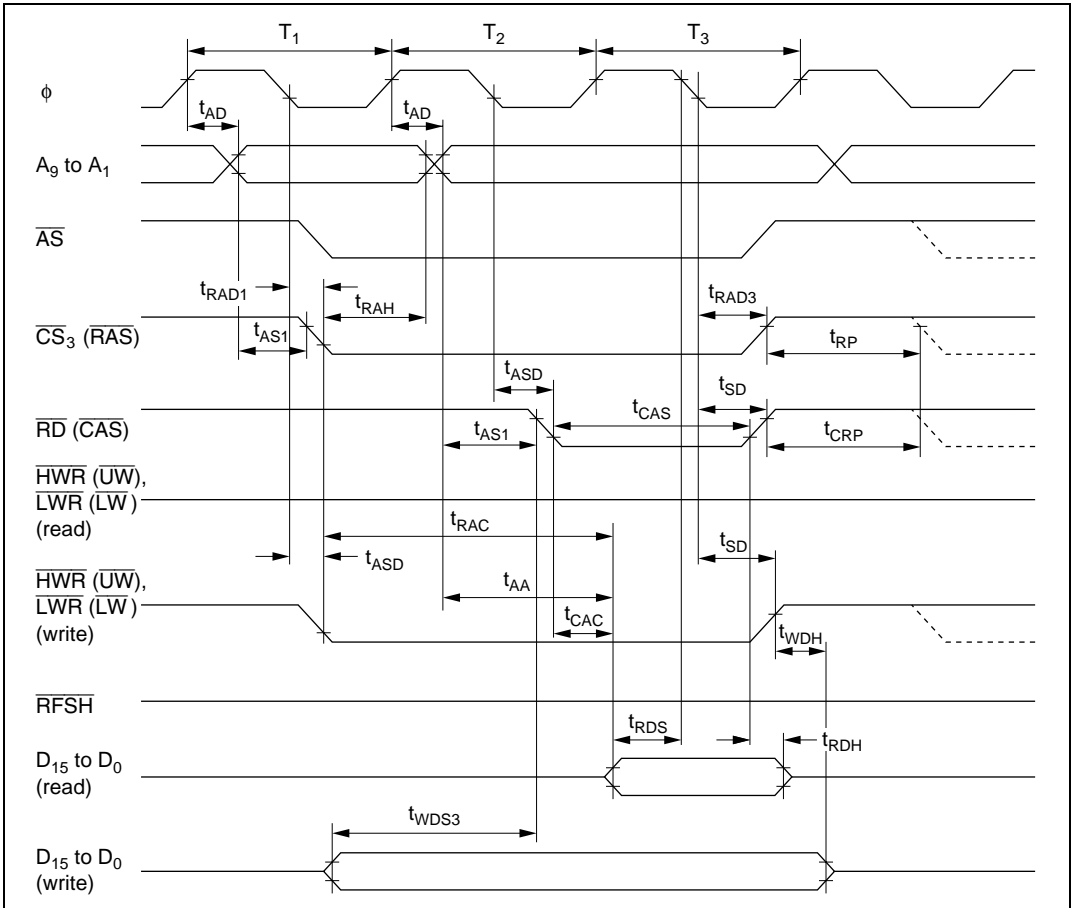

Figure 21.10 DRAM Bus Timing (Read/Write): Three-State Access
— $2\overline{WE}$ Mode —

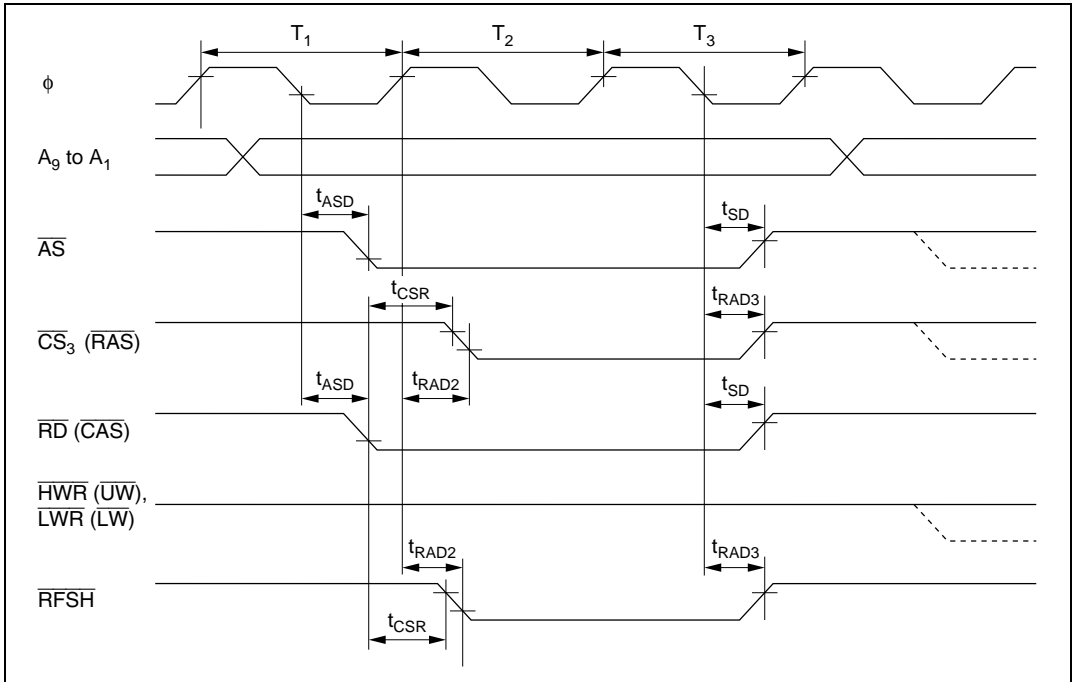

Figure 21.11 DRAM Bus Timing (Refresh Cycle): Three-State Access
— $\overline{2WE}$ Mode —

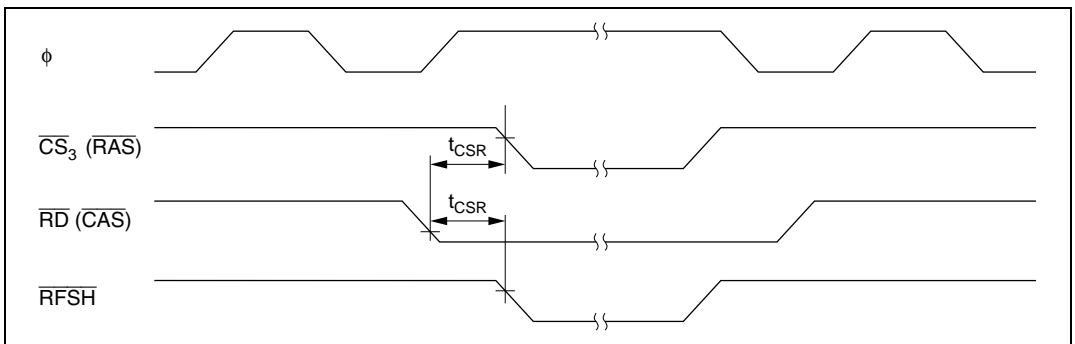

Figure 21.12 DRAM Bus Timing (Self-Refresh Mode)
— $\overline{2WE}$ Mode —

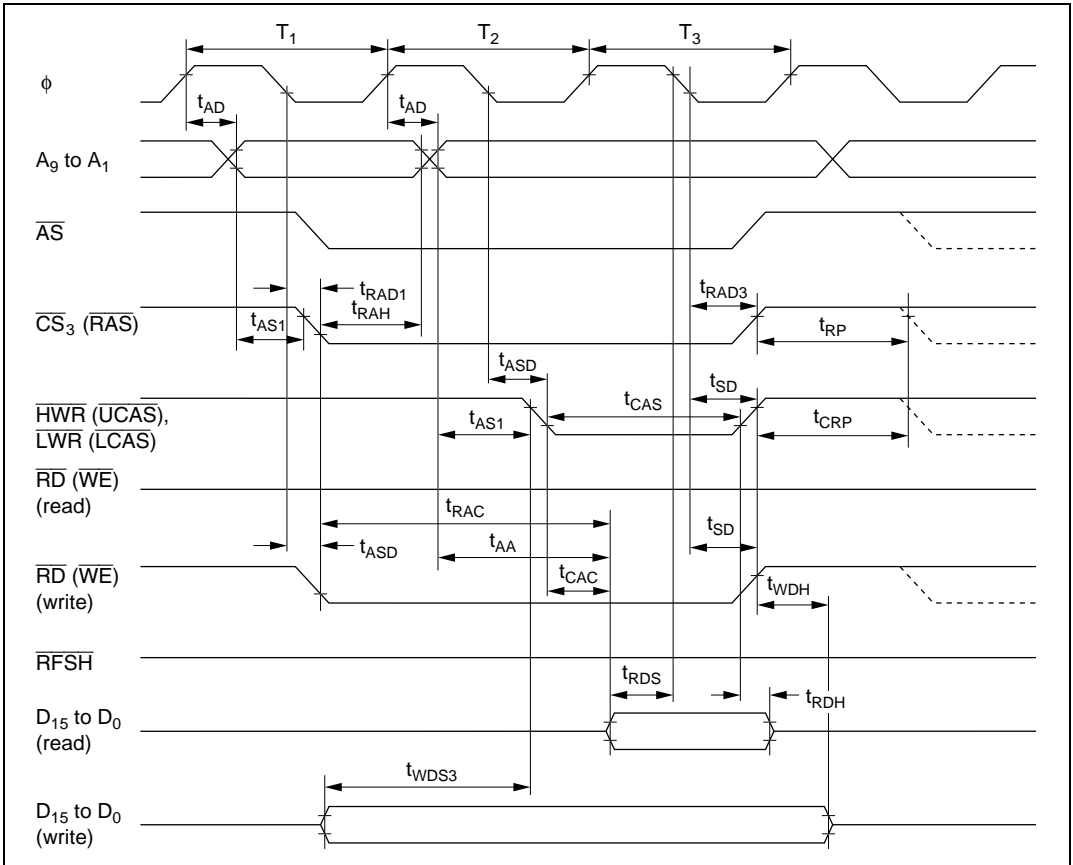

Figure 21.13 DRAM Bus Timing (Read/Write): Three-State Access
— 2CAS Mode —

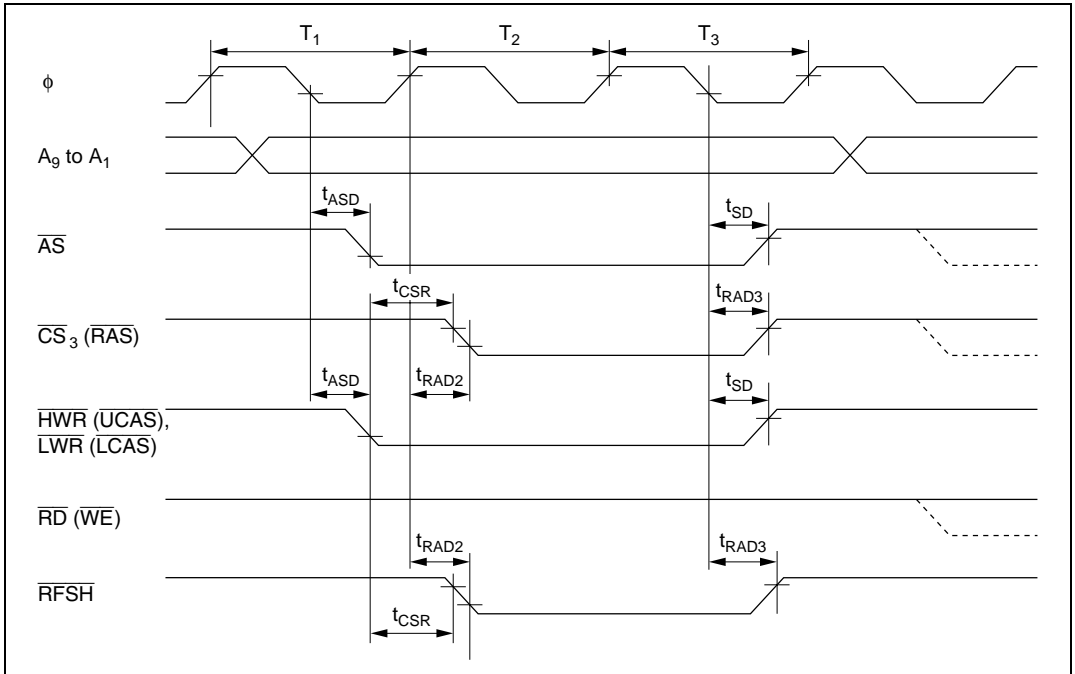

Figure 21.14 DRAM Bus Timing (Refresh Cycle): Three-State Access
— $\overline{2CAS}$ Mode —

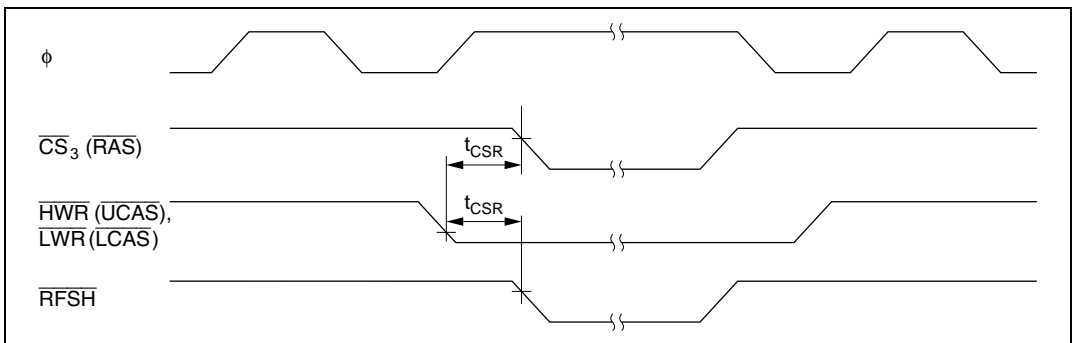

Figure 21.15 DRAM Bus Timing (Self-Refresh Mode)
— $\overline{2CAS}$ Mode —

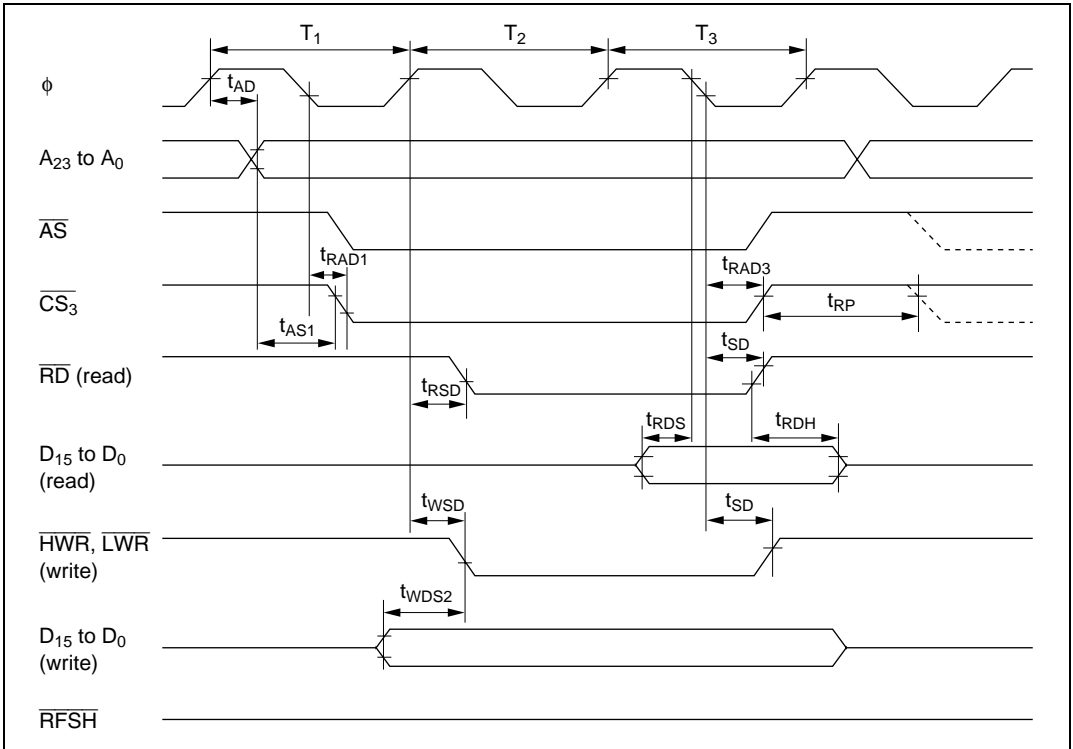

Figure 21.16 PSRAM Bus Timing (Read/Write): Three-State Access

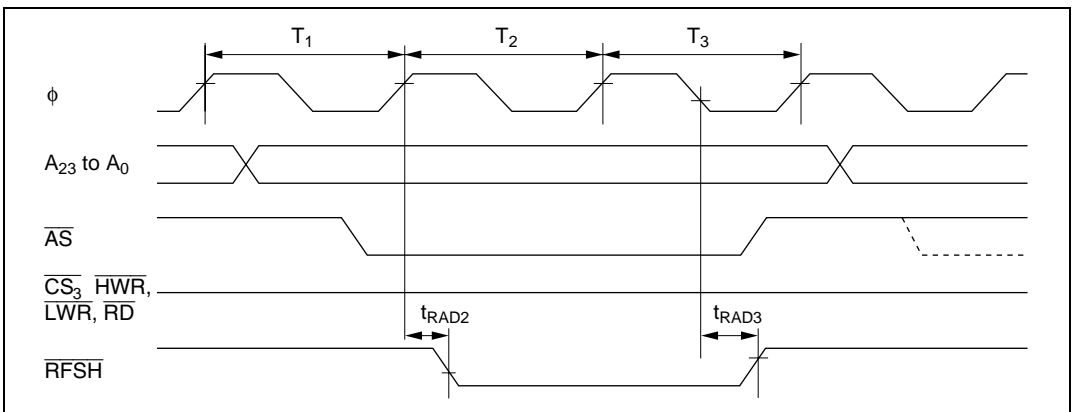

Figure 21.17 PSRAM Bus Timing (Refresh Cycle): Three-State Access

21.3.3 Control Signal Timing

Control signal timing is shown as follows:

- Reset input timing
Figure 21.18 shows the reset input timing.
- Reset output timing
Figure 21.19 shows the reset output timing.
- Interrupt input timing
Figure 21.20 shows the input timing for NMI and $\overline{\text{IRQ}}_5$ to $\overline{\text{IRQ}}_0$.
- Bus-release mode timing
Figure 21.21 shows the bus-release mode timing.

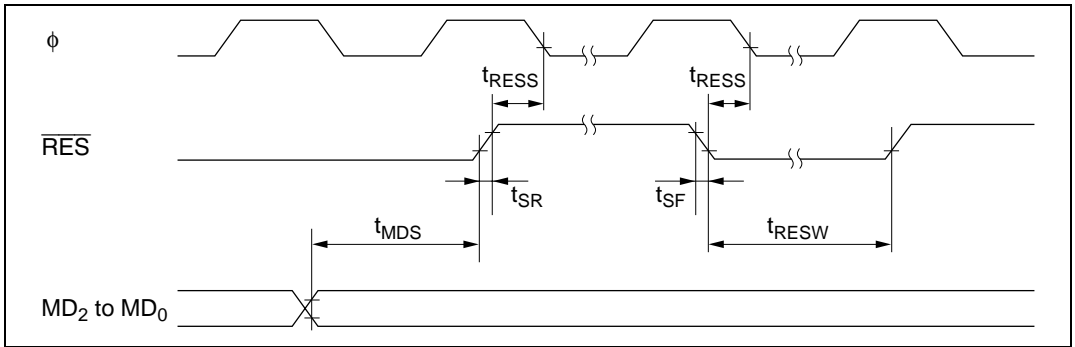

Figure 21.18 Reset Input Timing

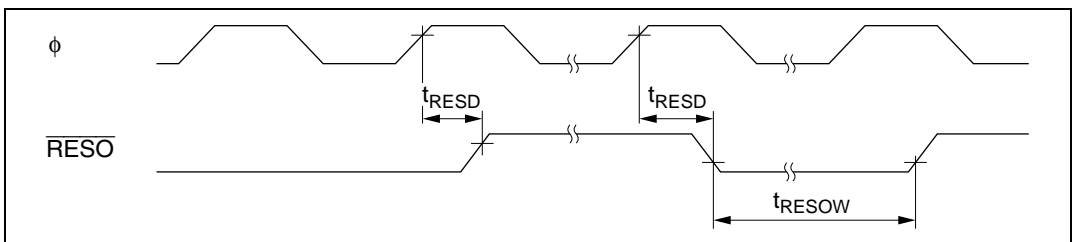

Figure 21.19 Reset Output Timing*

Note: * This is a function for models with on-chip mask ROM (H8/3048B, H8/3048, H8/3047, H8/3045, and H8/3044), PROM (H8/3048ZTAT), and on-chip flash memory with a dual power supply (H8/3048F). The function does not exist in the product with on-chip flash memory with a single power supply (H8/3048F-ONE).

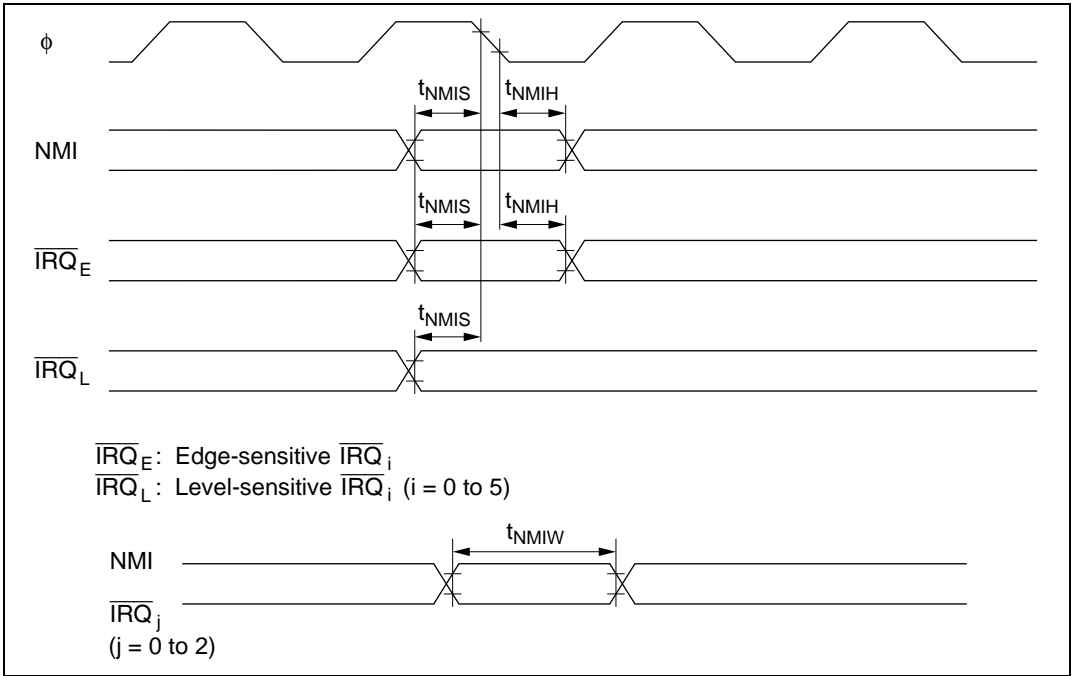

Figure 21.20 Interrupt Input Timing

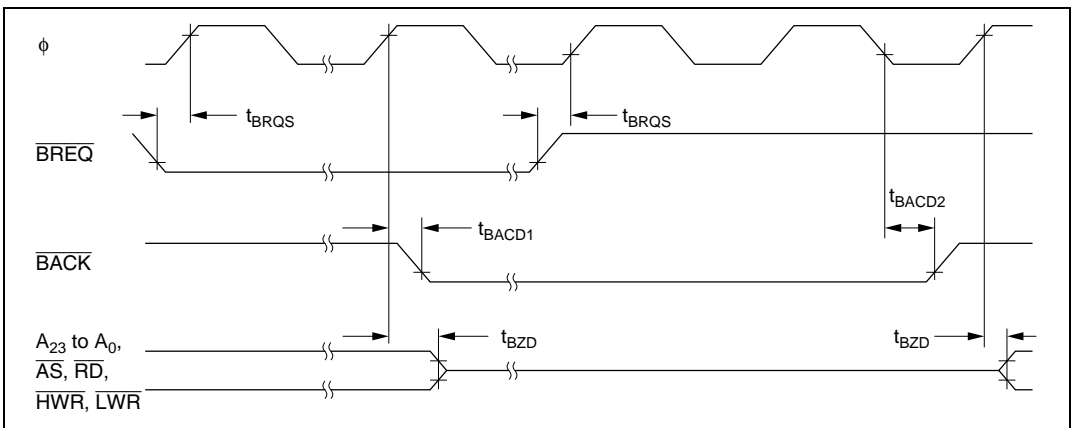

Figure 21.21 Bus-Release Mode Timing

21.3.4 Clock Timing

Clock timing is shown as follows:

- Oscillator settling timing

Figure 21.22 shows the oscillator settling timing.

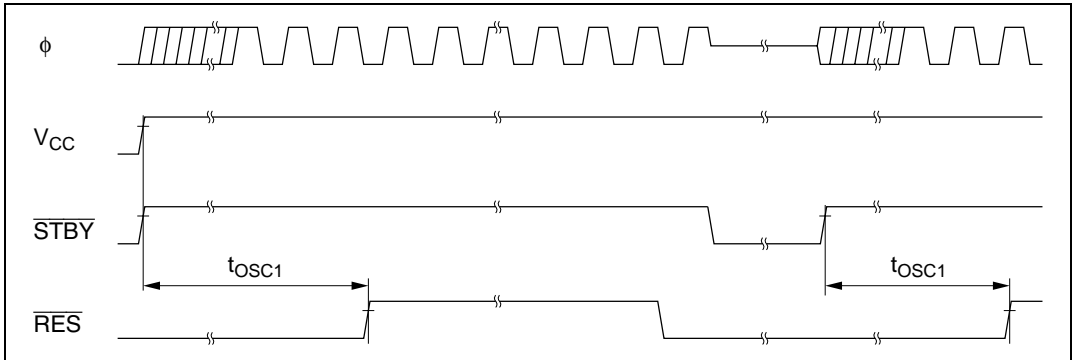

Figure 21.22 Oscillator Settling Timing

21.3.5 TPC and I/O Port Timing

Figure 21.23 shows the TPC and I/O port timing.

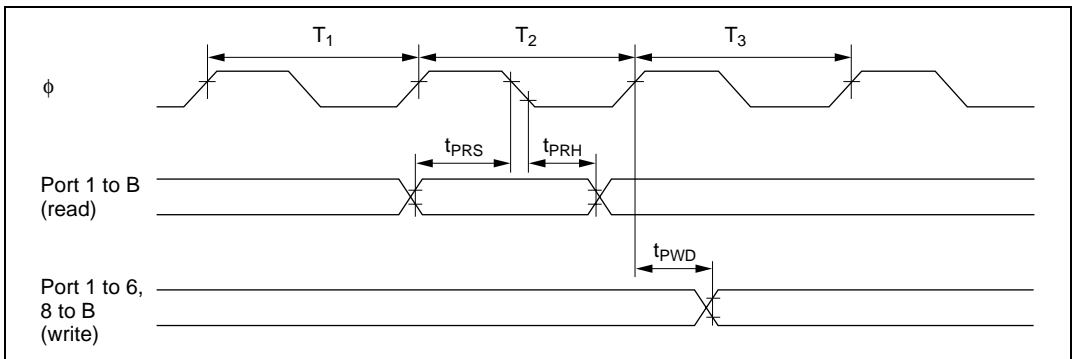

Figure 21.23 TPC and I/O Port Input/Output Timing

21.3.6 ITU Timing

ITU timing is shown as follows:

- ITU input/output timing
Figure 21.24 shows the ITU input/output timing.
- ITU external clock input timing
Figure 21.25 shows the ITU external clock input timing.

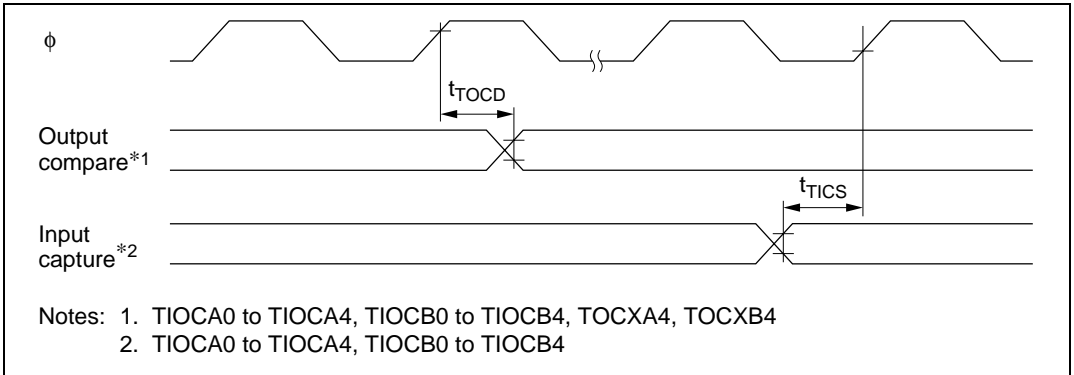

Figure 21.24 ITU Input/Output Timing

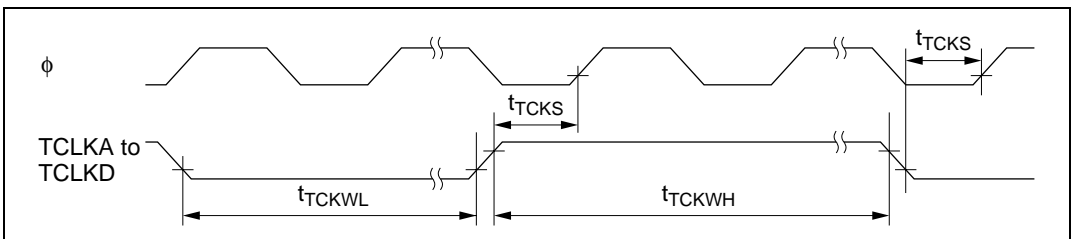

Figure 21.25 ITU External Clock Input Timing

21.3.7 SCI Input/Output Timing

SCI timing is shown as follows:

- SCI input clock timing
Figure 21.26 shows the SCK input clock timing.
- SCI input/output timing (synchronous mode)
Figure 21.27 shows the SCI input/output timing in synchronous mode.

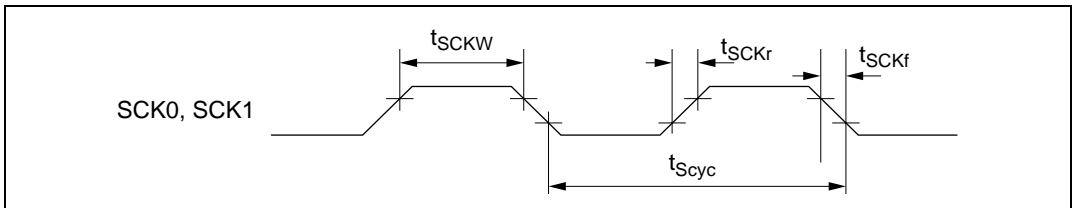

Figure 21.26 SCK Input Clock Timing

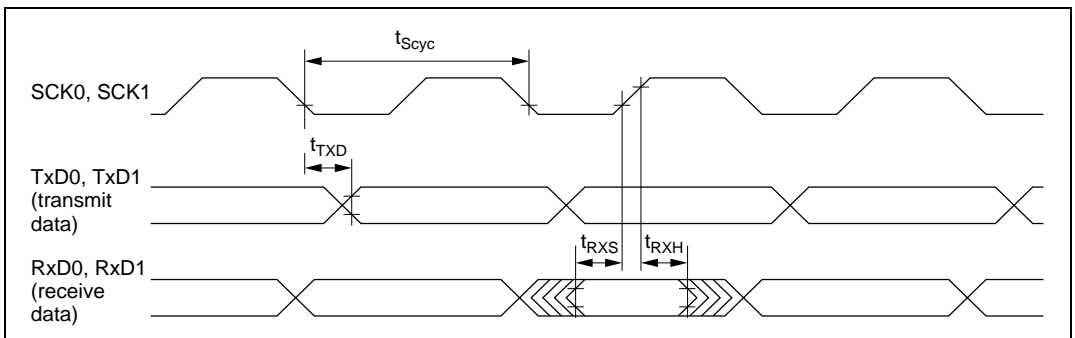

Figure 21.27 SCI Input/Output Timing in Synchronous Mode

21.3.8 DMAC Timing

DMAC timing is shown as follows.

- DMAC $\overline{\text{TEND}}$ output timing for 2 state access
Figure 21.28 shows the DMAC $\overline{\text{TEND}}$ output timing for 2 state access.
- DMAC $\overline{\text{TEND}}$ output timing for 3 state access
Figure 21.29 shows the DMAC $\overline{\text{TEND}}$ output timing for 3 state access.
- DMAC $\overline{\text{DREQ}}$ input timing
Figure 21.30 shows DMAC $\overline{\text{DREQ}}$ input timing.

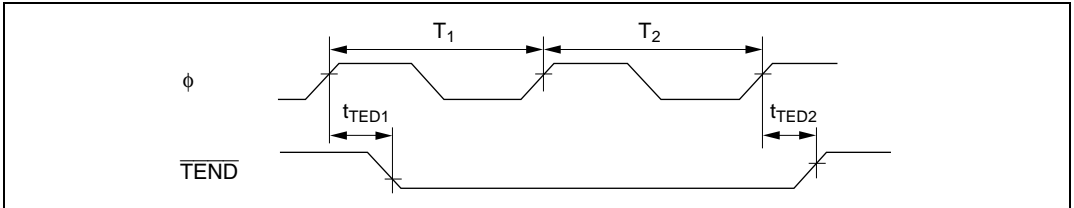

Figure 21.28 DMAC $\overline{\text{TEND}}$ Output Timing for 2 State Access

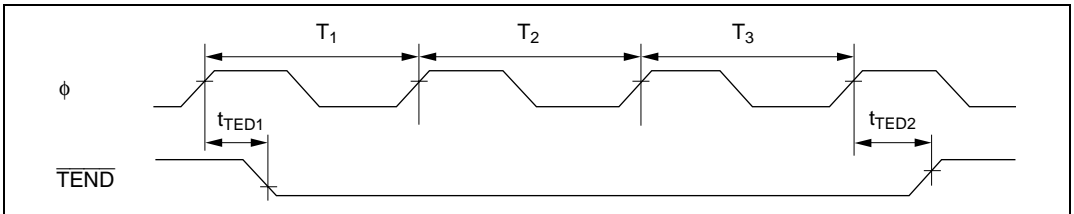

Figure 21.29 DMAC $\overline{\text{TEND}}$ Output Timing for 3 State Access

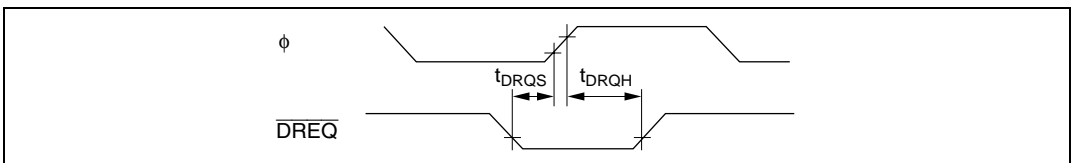

Figure 21.30 DMAC $\overline{\text{DREQ}}$ Input Timing

Appendix A Instruction Set

A.1 Instruction List

Operand Notation

Symbol	Description
Rd	General destination register
Rs	General source register
Rn	General register
ERd	General destination register (address register or 32-bit register)
ERs	General source register (address register or 32-bit register)
ERn	General register (32-bit register)
(EAd)	Destination operand
(EAs)	Source operand
PC	Program counter
SP	Stack pointer
CCR	Condition code register
N	N (negative) flag in CCR
Z	Z (zero) flag in CCR
V	V (overflow) flag in CCR
C	C (carry) flag in CCR
disp	Displacement
→	Transfer from the operand on the left to the operand on the right, or transition from the state on the left to the state on the right
+	Addition of the operands on both sides
−	Subtraction of the operand on the right from the operand on the left
×	Multiplication of the operands on both sides
÷	Division of the operand on the left by the operand on the right
∧	Logical AND of the operands on both sides
∨	Logical OR of the operands on both sides
⊕	Exclusive logical OR of the operands on both sides
¬	NOT (logical complement)
(), < >	Contents of operand

Note: General registers include 8-bit registers (R0H to R7H and R0L to R7L) and 16-bit registers (R0 to R7 and E0 to E7).

Condition Code Notation

Symbol	Description
↕	Changed according to execution result
*	Undetermined (no guaranteed value)
0	Cleared to 0
1	Set to 1
—	Not affected by execution of the instruction
Δ	Varies depending on conditions, described in notes

Table A.1 Instruction Set

1. Data transfer instructions

Mnemonic	Operand Size	Operation	Addressing Mode and Instruction Length (bytes)								Condition Code						No. of States ^{*1}	
			#xx	Rn	@ERn	@ (d, ERn)	@-ERn/@ERn+	@aa	@ (d, PC)	@@aa	I	H	N	Z	V	C	Normal	Advanced
MOV.B #xx:8, Rd	B	#xx:8 → Rd8	2									—	—	↑	↑	0	—	2
MOV.B Rs, Rd	B	Rs8 → Rd8		2								—	—	↑	↑	0	—	2
MOV.B @ERs, Rd	B	@ERs → Rd8			2							—	—	↑	↑	0	—	4
MOV.B @(d:16, ERs), Rd	B	@(d:16, ERs) → Rd8				4						—	—	↑	↑	0	—	6
MOV.B @(d:24, ERs), Rd	B	@(d:24, ERs) → Rd8					8					—	—	↑	↑	0	—	10
MOV.B @ERs+, Rd	B	@ERs → Rd8, ERs32+1 → ERs32						2				—	—	↑	↑	0	—	6
MOV.B @aa:8, Rd	B	@aa:8 → Rd8							2			—	—	↑	↑	0	—	4
MOV.B @aa:16, Rd	B	@aa:16 → Rd8								4		—	—	↑	↑	0	—	6
MOV.B @aa:24, Rd	B	@aa:24 → Rd8									6	—	—	↑	↑	0	—	8
MOV.B Rs, @ERd	B	Rs8 → @ERd			2							—	—	↑	↑	0	—	4
MOV.B Rs, @(d:16, ERd)	B	Rs8 → @(d:16, ERd)				4						—	—	↑	↑	0	—	6
MOV.B Rs, @(d:24, ERd)	B	Rs8 → @(d:24, ERd)					8					—	—	↑	↑	0	—	10
MOV.B Rs, @-ERd	B	ERd32-1 → ERd32, Rs8 → @ERd						2				—	—	↑	↑	0	—	6
MOV.B Rs, @aa:8	B	Rs8 → @aa:8							2			—	—	↑	↑	0	—	4
MOV.B Rs, @aa:16	B	Rs8 → @aa:16								4		—	—	↑	↑	0	—	6
MOV.B Rs, @aa:24	B	Rs8 → @aa:24									6	—	—	↑	↑	0	—	8
MOV.W #xx:16, Rd	W	#xx:16 → Rd16	4									—	—	↑	↑	0	—	4
MOV.W Rs, Rd	W	Rs16 → Rd16		2								—	—	↑	↑	0	—	2
MOV.W @ERs, Rd	W	@ERs → Rd16			2							—	—	↑	↑	0	—	4
MOV.W @(d:16, ERs), Rd	W	@(d:16, ERs) → Rd16				4						—	—	↑	↑	0	—	6
MOV.W @(d:24, ERs), Rd	W	@(d:24, ERs) → Rd16					8					—	—	↑	↑	0	—	10
MOV.W @ERs+, Rd	W	@ERs → Rd16, ERs32+2 → @ERd32						2				—	—	↑	↑	0	—	6
MOV.W @aa:16, Rd	W	@aa:16 → Rd16							4			—	—	↑	↑	0	—	6
MOV.W @aa:24, Rd	W	@aa:24 → Rd16								6		—	—	↑	↑	0	—	8
MOV.W Rs, @ERd	W	Rs16 → @ERd			2							—	—	↑	↑	0	—	4
MOV.W Rs, @(d:16, ERd)	W	Rs16 → @(d:16, ERd)				4						—	—	↑	↑	0	—	6
MOV.W Rs, @(d:24, ERd)	W	Rs16 → @(d:24, ERd)					8					—	—	↑	↑	0	—	10

Mnemonic	Operand Size	Operation	Addressing Mode and Instruction Length (bytes)								Condition Code						No. of States ^{*1}		
			#xx	Rn	@ERn	@ (d, ERn)	@-ERn/@ERn+	@aa	@ (d, PC)	@@aa		I	H	N	Z	V	C	Normal	Advanced
MOV.W Rs, @-ERd	W	ERd32-2 → ERd32, Rs16 → @ERd					2						—	—	↑	↑	0	—	6
MOV.W Rs, @aa:16	W	Rs16 → @aa:16						4					—	—	↑	↑	0	—	6
MOV.W Rs, @aa:24	W	Rs16 → @aa:24						6					—	—	↑	↑	0	—	8
MOV.L #xx:32, Rd	L	#xx:32 → Rd32	6										—	—	↑	↑	0	—	6
MOV.L ERs, ERd	L	ERs32 → ERd32		2									—	—	↑	↑	0	—	2
MOV.L @ERs, ERd	L	@ERs → ERd32			4								—	—	↑	↑	0	—	8
MOV.L @(d:16, ERs), ERd	L	@(d:16, ERs) → ERd32				6							—	—	↑	↑	0	—	10
MOV.L @(d:24, ERs), ERd	L	@(d:24, ERs) → ERd32				10							—	—	↑	↑	0	—	14
MOV.L @ERs+, ERd	L	@ERs → ERd32, ERs32+4 → ERs32				4							—	—	↑	↑	0	—	10
MOV.L @aa:16, ERd	L	@aa:16 → ERd32						6					—	—	↑	↑	0	—	10
MOV.L @aa:24, ERd	L	@aa:24 → ERd32						8					—	—	↑	↑	0	—	12
MOV.L ERs, @ERd	L	ERs32 → @ERd			4								—	—	↑	↑	0	—	8
MOV.L ERs, @(d:16, ERd)	L	ERs32 → @(d:16, ERd)				6							—	—	↑	↑	0	—	10
MOV.L ERs, @(d:24, ERd)	L	ERs32 → @(d:24, ERd)				10							—	—	↑	↑	0	—	14
MOV.L ERs, @-ERd	L	ERd32-4 → ERd32, ERs32 → @ERd				4							—	—	↑	↑	0	—	10
MOV.L ERs, @aa:16	L	ERs32 → @aa:16						6					—	—	↑	↑	0	—	10
MOV.L ERs, @aa:24	L	ERs32 → @aa:24						8					—	—	↑	↑	0	—	12
POP.W Rn	W	@SP → Rn16, SP+2 → SP								2			—	—	↑	↑	0	—	6
POP.L ERn	L	@SP → ERn32, SP+4 → SP								4			—	—	↑	↑	0	—	10
PUSH.W Rn	W	SP-2 → SP, Rn16 → @SP								2			—	—	↑	↑	0	—	6
PUSH.L ERn	L	SP-4 → SP, ERn32 → @SP								4			—	—	↑	↑	0	—	10
MOVFPE @aa:16, Rd	B	Cannot be used in the H8/3048B Group						4					Cannot be used in the H8/3048B Group						
MOVTPE Rs, @aa:16	B	Cannot be used in the H8/3048B Group						4					Cannot be used in the H8/3048B Group						

Mnemonic	Operand Size	Operation	Addressing Mode and Instruction Length (bytes)								Condition Code						No. of States*1		
			#xx	Rn	@ERn	@ (d, ERn)	@-ERn/@ERn+	@aa	@ (d, PC)	@@aa		I	H	N	Z	V	C	Normal	Advanced
DEC.L #1, ERd	L	ERd32-1 → ERd32		2									—	—	↑	↓	↓	—	2
DEC.L #2, ERd	L	ERd32-2 → ERd32		2									—	—	↑	↓	↓	—	2
DAS.Rd	B	Rd8 decimal adjust → Rd8		2									—	*	↑	↓	*	—	2
MULXU. B Rs, Rd	B	Rd8 × Rs8 → Rd16 (unsigned multiplication)		2									—	—	—	—	—	—	14
MULXU. W Rs, ERd	W	Rd16 × Rs16 → ERd32 (unsigned multiplication)		2									—	—	—	—	—	—	22
MULXS. B Rs, Rd	B	Rd8 × Rs8 → Rd16 (signed multiplication)		4									—	—	↑	↓	—	—	16
MULXS. W Rs, ERd	W	Rd16 × Rs16 → ERd32 (signed multiplication)		4									—	—	↑	↓	—	—	24
DIVXU. B Rs, Rd	B	Rd16 ÷ Rs8 → Rd16 (RdH: remainder, RdL: quotient) (unsigned division)		2									—	—	(6)	(7)	—	—	14
DIVXU. W Rs, ERd	W	ERd32 ÷ Rs16 → ERd32 (Ed: remainder, Rd: quotient) (unsigned division)		2									—	—	(6)	(7)	—	—	22
DIVXS. B Rs, Rd	B	Rd16 ÷ Rs8 → Rd16 (RdH: remainder, RdL: quotient) (signed division)		4									—	—	(8)	(7)	—	—	16
DIVXS. W Rs, ERd	W	ERd32 ÷ Rs16 → ERd32 (Ed: remainder, Rd: quotient) (signed division)		4									—	—	(8)	(7)	—	—	24
CMP.B #xx:8, Rd	B	Rd8-#xx:8		2									—	↑	↓	↓	↓	↓	2
CMP.B Rs, Rd	B	Rd8-Rs8		2									—	↑	↓	↓	↓	↓	2
CMP.W #xx:16, Rd	W	Rd16-#xx:16		4									—	(1)	↑	↓	↓	↓	4
CMP.W Rs, Rd	W	Rd16-Rs16		2									—	(1)	↑	↓	↓	↓	2
CMP.L #xx:32, ERd	L	ERd32-#xx:32		6									—	(2)	↑	↓	↓	↓	4
CMP.L ERs, ERd	L	ERd32-ERs32		2									—	(2)	↑	↓	↓	↓	2

Mnemonic	Operand Size	Operation	Addressing Mode and Instruction Length (bytes)								Condition Code						No. of States ^{*1}		
			#xx	Rn	@ ERn	@ (d, ERn)	@-ERn/@ERn+	@aa	@ (d, PC)	@ @aa		I	H	N	Z	V	C	Normal	Advanced
NEG.B Rd	B	0-Rd8 → Rd8		2														2	
NEG.W Rd	W	0-Rd16 → Rd16		2														2	
NEG.L ERd	L	0-ERd32 → ERd32		2														2	
EXTU.W Rd	W	0 → (<bits 15 to 8> of Rd16)		2								0	↑	0	—			2	
EXTU.L ERd	L	0 → (<bits 31 to 16> of ERd32)		2								0	↑	0	—			2	
EXTS.W Rd	W	(<bit 7> of Rd16) → (<bits 15 to 8> of Rd16)		2								↑	↑	0	—			2	
EXTS.L ERd	L	(<bit 15> of ERd32) → (<bits 31 to 16> of ERd32)		2								↑	↑	0	—			2	

3. Logic instructions

Mnemonic	Operand Size	Operation	Addressing Mode and Instruction Length (bytes)								Condition Code						No. of States*1		
			#xx	Rn	@ ERn	@ (d, ERn)	@ -ERn/ @ERn+	@ aa	@ (d, PC)	@ @aa		I	H	N	Z	V	C	Normal	Advanced
AND.B #xx:8, Rd	B	Rd8 \wedge #xx:8 \rightarrow Rd8	2										\uparrow	\uparrow	0	—	2		
AND.B Rs, Rd	B	Rd8 \wedge Rs8 \rightarrow Rd8		2									\uparrow	\uparrow	0	—	2		
AND.W #xx:16, Rd	W	Rd16 \wedge #xx:16 \rightarrow Rd16	4										\uparrow	\uparrow	0	—	4		
AND.W Rs, Rd	W	Rd16 \wedge Rs16 \rightarrow Rd16		2									\uparrow	\uparrow	0	—	2		
AND.L #xx:32, ERd	L	ERd32 \wedge #xx:32 \rightarrow ERd32	6										\uparrow	\uparrow	0	—	6		
AND.L ERs, ERd	L	ERd32 \wedge ERs32 \rightarrow ERd32		4									\uparrow	\uparrow	0	—	4		
OR.B #xx:8, Rd	B	Rd8 \vee #xx:8 \rightarrow Rd8	2										\uparrow	\uparrow	0	—	2		
OR.B Rs, Rd	B	Rd8 \vee Rs8 \rightarrow Rd8		2									\uparrow	\uparrow	0	—	2		
OR.W #xx:16, Rd	W	Rd16 \vee #xx:16 \rightarrow Rd16	4										\uparrow	\uparrow	0	—	4		
OR.W Rs, Rd	W	Rd16 \vee Rs16 \rightarrow Rd16		2									\uparrow	\uparrow	0	—	2		
OR.L #xx:32, ERd	L	ERd32 \vee #xx:32 \rightarrow ERd32	6										\uparrow	\uparrow	0	—	6		
OR.L ERs, ERd	L	ERd32 \vee ERs32 \rightarrow ERd32		4									\uparrow	\uparrow	0	—	4		
XOR.B #xx:8, Rd	B	Rd8 \oplus #xx:8 \rightarrow Rd8	2										\uparrow	\uparrow	0	—	2		
XOR.B Rs, Rd	B	Rd8 \oplus Rs8 \rightarrow Rd8		2									\uparrow	\uparrow	0	—	2		
XOR.W #xx:16, Rd	W	Rd16 \oplus #xx:16 \rightarrow Rd16	4										\uparrow	\uparrow	0	—	4		
XOR.W Rs, Rd	W	Rd16 \oplus Rs16 \rightarrow Rd16		2									\uparrow	\uparrow	0	—	2		
XOR.L #xx:32, ERd	L	ERd32 \oplus #xx:32 \rightarrow ERd32	6										\uparrow	\uparrow	0	—	6		
XOR.L ERs, ERd	L	ERd32 \oplus ERs32 \rightarrow ERd32		4									\uparrow	\uparrow	0	—	4		
NOT.B Rd	B	\neg Rd8 \rightarrow Rd8		2									\uparrow	\uparrow	0	—	2		
NOT.W Rd	W	\neg Rd16 \rightarrow Rd16		2									\uparrow	\uparrow	0	—	2		
NOT.L ERd	L	\neg Rd32 \rightarrow Rd32		2									\uparrow	\uparrow	0	—	2		

5. Bit manipulation instructions

Mnemonic	Operand Size	Operation	Addressing Mode and Instruction Length (bytes)								Condition Code						No. of States*1		
			#xx	Rn	@ERn	@ (d, ERn)	@-ERn/@ERn+	@aa	@ (d, PC)	@@aa		I	H	N	Z	V	C	Normal	Advanced
BSET #xx:3, Rd	B	(#xx:3 of Rd8) ← 1		2															2
BSET #xx:3, @ERd	B	(#xx:3 of @ERd) ← 1			4														8
BSET #xx:3, @aa:8	B	(#xx:3 of @aa:8) ← 1						4											8
BSET Rn, Rd	B	(Rn8 of Rd8) ← 1		2															2
BSET Rn, @ERd	B	(Rn8 of @ERd) ← 1			4														8
BSET Rn, @aa:8	B	(Rn8 of @aa:8) ← 1						4											8
BCLR #xx:3, Rd	B	(#xx:3 of Rd8) ← 0		2															2
BCLR #xx:3, @ERd	B	(#xx:3 of @ERd) ← 0			4														8
BCLR #xx:3, @aa:8	B	(#xx:3 of @aa:8) ← 0						4											8
BCLR Rn, Rd	B	(Rn8 of Rd8) ← 0		2															2
BCLR Rn, @ERd	B	(Rn8 of @ERd) ← 0			4														8
BCLR Rn, @aa:8	B	(Rn8 of @aa:8) ← 0						4											8
BNOT #xx:3, Rd	B	(#xx:3 of Rd8) ← ¬(#xx:3 of Rd8)		2															2
BNOT #xx:3, @ERd	B	(#xx:3 of @ERd) ← ¬(#xx:3 of @ERd)			4														8
BNOT #xx:3, @aa:8	B	(#xx:3 of @aa:8) ← ¬(#xx:3 of @aa:8)						4											8
BNOT Rn, Rd	B	(Rn8 of Rd8) ← ¬(Rn8 of Rd8)		2															2
BNOT Rn, @ERd	B	(Rn8 of @ERd) ← ¬(Rn8 of @ERd)			4														8
BNOT Rn, @aa:8	B	(Rn8 of @aa:8) ← ¬(Rn8 of @aa:8)						4											8
BTST #xx:3, Rd	B	¬(#xx:3 of Rd8) → Z		2									↓						2
BTST #xx:3, @ERd	B	¬(#xx:3 of @ERd) → Z			4								↓						6
BTST #xx:3, @aa:8	B	¬(#xx:3 of @aa:8) → Z						4					↓						6
BTST Rn, Rd	B	¬(Rn8 of @Rd8) → Z		2									↓						2
BTST Rn, @ERd	B	¬(Rn8 of @ERd) → Z			4								↓						6
BTST Rn, @aa:8	B	¬(Rn8 of @aa:8) → Z						4					↓						6
BLD #xx:3, Rd	B	(#xx:3 of Rd8) → C		2													↓		2

6. Branching instructions

Mnemonic	Operand Size	Operation	Addressing Mode and Instruction Length (bytes)								Condition Code						No. of States*1		
			Branch Condition	#xx	Rn	@ ERn	@ (d, ERn)	@ -ERn/@ ERn+	@aa	@ (d, PC)	@ @aa	I	H	N	Z	V	C	Normal	Advanced
BRA d:8 (BT d:8)	—	If condition is true then PC ← PC+d else next;	Always						2									4	
BRA d:16 (BT d:16)	—								4										6
BRN d:8 (BF d:8)	—		Never						2									4	
BRN d:16 (BF d:16)	—								4										6
BHI d:8	—		C ∨ Z = 0						2									4	
BHI d:16	—								4										6
BLS d:8	—		C ∨ Z = 1						2									4	
BLS d:16	—								4										6
BCC d:8 (BHS d:8)	—		C = 0						2									4	
BCC d:16 (BHS d:16)	—								4										6
BCS d:8 (BLO d:8)	—		C = 1						2									4	
BCS d:16 (BLO d:16)	—								4										6
BNE d:8	—		Z = 0						2									4	
BNE d:16	—								4										6
BEQ d:8	—		Z = 1						2									4	
BEQ d:16	—								4										6
BVC d:8	—		V = 0						2									4	
BVC d:16	—								4										6
BVS d:8	—		V = 1						2									4	
BVS d:16	—								4										6
BPL d:8	—		N = 0						2									4	
BPL d:16	—								4										6
BMI d:8	—		N = 1						2									4	
BMI d:16	—								4										6
BGE d:8	—		N⊕V = 0						2									4	
BGE d:16	—								4										6
BLT d:8	—		N⊕V = 1						2									4	
BLT d:16	—								4										6
BGT d:8	—		Z ∨ (N⊕V) = 0						2									4	
BGT d:16	—								4										6
BLE d:8	—		Z ∨ (N⊕V) = 1						2									4	
BLE d:16	—								4										6

Mnemonic	Operand Size	Operation	Addressing Mode and Instruction Length (bytes)								Condition Code						No. of States ^{*1}		
			#xx	Rn	@ERn	@ (d, ERn)	@-ERn/@ERn+	@aa	@ (d, PC)	@@aa		I	H	N	Z	V	C	Normal	Advanced
JMP @ERn	—	PC ← ERn			2													4	
JMP @aa:24	—	PC ← aa:24					4											6	
JMP @@aa:8	—	PC ← @aa:8							2									8 10	
BSR d:8	—	PC → @-SP PC ← PC+d:8						2										6 8	
BSR d:16	—	PC → @-SP PC ← PC+d:16						4										8 10	
JSR @ERn	—	PC → @-SP PC ← @ERn			2													6 8	
JSR @aa:24	—	PC → @-SP PC ← @aa:24					4											8 10	
JSR @@aa:8	—	PC → @-SP PC ← @aa:8							2									8 12	
RTS	—	PC ← @SP+							2									8 10	

7. System control instructions

Mnemonic	Operand Size	Operation	Addressing Mode and Instruction Length (bytes)								Condition Code						No. of States*1		
			#xx	Rn	@ERn	@ (d, ERn)	@-ERn/@ERn+	@aa	@ (d, PC)	@@aa		I	H	N	Z	V	C	Normal	Advanced
TRAPA #x:2	—	PC → @-SP, CCR → @-SP, <vector> → PC															14	16	
RTE	—	CCR ← @SP+, PC ← @SP+									↑	↑	↑	↑	↑	↑		10	
SLEEP	—	Transition to power-down state									—	—	—	—	—	—		2	
LDC #xx:8, CCR	B	#xx:8 → CCR	2								↑	↑	↑	↑	↑	↑		2	
LDC Rs, CCR	B	Rs8 → CCR		2							↑	↑	↑	↑	↑	↑		2	
LDC @ERs, CCR	W	@ERs → CCR			4						↑	↑	↑	↑	↑	↑		6	
LDC @(d:16, ERs), CCR	W	@(d:16, ERs) → CCR				6					↑	↑	↑	↑	↑	↑		8	
LDC @(d:24, ERs), CCR	W	@(d:24, ERs) → CCR				10					↑	↑	↑	↑	↑	↑		12	
LDC @ERs+, CCR	W	@ERs → CCR, ERs32+2 → ERs32					4				↑	↑	↑	↑	↑	↑		8	
LDC @aa:16, CCR	W	@aa:16 → CCR						6			↑	↑	↑	↑	↑	↑		8	
LDC @aa:24, CCR	W	@aa:24 → CCR						8			↑	↑	↑	↑	↑	↑		10	
STC CCR, Rd	B	CCR → Rd8		2							—	—	—	—	—	—		2	
STC CCR, @ERd	W	CCR → @ERd			4						—	—	—	—	—	—		6	
STC CCR, @(d:16, ERd)	W	CCR → @(d:16, ERd)				6					—	—	—	—	—	—		8	
STC CCR, @(d:24, ERd)	W	CCR → @(d:24, ERd)				10					—	—	—	—	—	—		12	
STC CCR, @-ERd	W	ERd32-2 → ERd32, CCR → @ERd					4				—	—	—	—	—	—		8	
STC CCR, @aa:16	W	CCR → @aa:16						6			—	—	—	—	—	—		8	
STC CCR, @aa:24	W	CCR → @aa:24						8			—	—	—	—	—	—		10	
ANDC #xx:8, CCR	B	CCR^#xx:8 → CCR	2								↑	↑	↑	↑	↑	↑		2	
ORC #xx:8, CCR	B	CCR∨#xx:8 → CCR	2								↑	↑	↑	↑	↑	↑		2	
XORC #xx:8, CCR	B	CCR@#xx:8 → CCR	2								↑	↑	↑	↑	↑	↑		2	
NOP	—	PC ← PC+2								2	—	—	—	—	—	—		2	

8. Block transfer instructions

Mnemonic	Operand Size	Operation	Addressing Mode and Instruction Length (bytes)								Condition Code	No. of States*1							
			#xx	Rn	@ERn	@ (d, ERn)	@-ERn/@ERn+	@aa	@ (d, PC)	@ @aa		I	H	N	Z	V	C	Normal	Advanced
EEPMOV. B	—	if R4L ≠ 0 then repeat @R5 → @R6 R5+1 → R5 R6+1 → R6 R4L-1 → R4L until R4L=0 else next									4	—	—	—	—	—	—	8+ 4n*2	
EEPMOV. W	—	if R4 ≠ 0 then repeat @R5 → @R6 R5+1 → R5 R6+1 → R6 R4-1 → R4 until R4=0 else next									4	—	—	—	—	—	—	8+ 4n*2	

- Notes:
- The number of states is the number of states required for execution when the instruction and its operands are located in on-chip memory. For other cases see section A.3, Number of States Required for Execution.
 - n is the value set in register R4L or R4.
 - Set to 1 when a carry or borrow occurs at bit 11; otherwise cleared to 0.
 - Set to 1 when a carry or borrow occurs at bit 27; otherwise cleared to 0.
 - Retains its previous value when the result is zero; otherwise cleared to 0.
 - Set to 1 when the adjustment produces a carry; otherwise retains its previous value.
 - The number of states required for execution of an instruction that transfers data in synchronization with the E clock is variable.
 - Set to 1 when the divisor is negative; otherwise cleared to 0.
 - Set to 1 when the divisor is zero; otherwise cleared to 0.
 - Set to 1 when the quotient is negative; otherwise cleared to 0.

A.2 Operation Code Map

Table A.2 Operation Code Map

Instruction code:		1st byte		2nd byte		Instruction when most significant bit of BH is 0.											Instruction when most significant bit of BH is 1.										
		AH	AL	BH	BL	0	1	2	3	4	5	6	7	8	9	A	B	C	D	E	F						
0	NOP	Table A.2 (2)	STC	LDC	ORC	XORC	ANDC	LDC	LDC	AND	ADD	Table A.2 (2)	Table A.2 (2)	Table A.2 (2)	Table A.2 (2)	Table A.2 (2)	Table A.2 (2)	Table A.2 (2)	Table A.2 (2)	Table A.2 (2)	Table A.2 (2)	Table A.2 (2)					
1	Table A.2 (2)	Table A.2 (2)	Table A.2 (2)	Table A.2 (2)	OR.B	XOR.B	AND.B	Table A.2 (2)	Table A.2 (2)	SUB	SUB	Table A.2 (2)	Table A.2 (2)	Table A.2 (2)	Table A.2 (2)	Table A.2 (2)	Table A.2 (2)	Table A.2 (2)	Table A.2 (2)	Table A.2 (2)	Table A.2 (2)	Table A.2 (2)					
2	MOV.B																										
3	MOV																										
4	BRA	BRN	BHI	BLS	BCC	BCS	BNE	BEQ	BVC	BVS	BPL	BMI	BGE	BLT	BGT	BLE											
5	MULXU	DIVXU	MULXU	DIVXU	RTS	BSR	RTE	TRAPA	Table A.2 (2)	Table A.2 (2)	JMP	BSR	JSR														
6	BSET	BNOT	BCLR	BTST	OR	XOR	AND	BSL	MOV																		
7			BOR		BAND	BXOR	BAND	BAND	BAND	MOV	Table A.2 (2)	Table A.2 (2)	Table A.2 (2)	Table A.2 (2)	Table A.2 (2)	Table A.2 (2)	Table A.2 (2)	Table A.2 (2)	Table A.2 (2)	Table A.2 (2)	Table A.2 (2)	Table A.2 (2)					
8	ADD																										
9	ADDX																										
A	CMP																										
B	SUBX																										
C	OR																										
D	XOR																										
E	AND																										
F	MOV																										

Instruction code:

1st byte	2nd byte
AH AL	BH BL

BH AH/AL	0	1	2	3	4	5	6	7	8	9	A	B	C	D	E	F
01	MOV				LDC/STC				SLEEP				Table A.2 (3)	Table A.2 (3)		Table A.2 (3)
0A	INC	ADD														
0B	ADDS					INC		INC	ADDS					INC		INC
0F	DAA	MOV														
10	SHLL			SHLL					SHAL			SHAL				
11	SHLR			SHLR					SHAR			SHAR				
12	ROTXL			ROTXL					ROTL			ROTL				
13	ROTXR			ROTXR					ROTR			ROTR				
17	NOT			NOT				EXTU	NEG			NEG		EXTS		EXTS
1A	DEC	SUB														
1B	SUBS					DEC		DEC	SUBS					DEC		DEC
1F	DAS	CMP														
58	BRA	BRN		BHI	BLS	BCC	BNE	BEQ	BVC	BVS	BPL	BMI	BGE	BLT	BGT	BLE
79	MOV	ADD		CMP	SUB	OR	XOR	AND								
7A	MOV	ADD		CMP	SUB	OR	XOR	AND								

Instruction code:

1st byte		2nd byte		3rd byte		4th byte	
AH	AL	BH	BL	CH	CL	DH	DL

← Instruction when most significant bit of DH is 0.
← Instruction when most significant bit of DH is 1.

CL	0	1	2	3	4	5	6	7	8	9	A	B	C	D	E	F
AH ALBH BLCH																
01406										LDC		LDC		LDC		LDC
01C05	MULXS			MULXS												
01D05		DIVXS			DIVXS											
01F06					OR	XOR	AND									
7C706*1																
7C707*1																
7D706*1	BSET		BNOT													
7D707*1	BSET		BNOT													
7Eaa6*2																
7Eaa7*2																
7Faa6*2	BSET		BNOT													
7Faa7*2	BSET		BNOT													

Notes: 1. r is the register designation field.
 2. aa is the absolute address field.

A.3 Number of States Required for Execution

The tables in this section can be used to calculate the number of states required for instruction execution by the H8/300H CPU. Table A.4 indicates the number of instruction fetch, data read/write, and other cycles occurring in each instruction. Table A.3 indicates the number of states required per cycle according to the bus size. The number of states required for execution of an instruction can be calculated from these two tables as follows:

$$\text{Number of states} = I \times S_I + J \times S_J + K \times S_K + L \times S_L + M \times S_M + N \times S_N$$

Examples of Calculation of Number of States Required for Execution

Examples: Advanced mode, stack located in external address space, on-chip supporting modules accessed with 8-bit bus width, external devices accessed in three states with one wait state and 16-bit bus width.

BSET #0, @FFFFC7:8

From table A.4,

$$I = L = 2 \text{ and } J = K = M = N = 0$$

From table A.3,

$$S_I = 4 \text{ and } S_L = 3$$

$$\text{Number of states} = 2 \times 4 + 2 \times 3 = 14$$

JSR @@30

From table A.4,

$$I = J = K = 2 \text{ and } L = M = N = 0$$

From table A.3,

$$S_I = S_J = S_K = 4$$

$$\text{Number of states} = 2 \times 4 + 2 \times 4 + 2 \times 4 = 24$$

Table A.3 Number of States per Cycle

Cycle		Access Conditions						
		On-Chip Memory	On-Chip Supporting Module		External Device			
			8-Bit Bus	16-Bit Bus	8-Bit Bus		16-Bit Bus	
					2-State Access	3-State Access	2-State Access	3-State Access
Instruction fetch	S_i	2	6	3	4	6 + 2m	2	3 + m
Branch address read	S_j							
Stack operation	S_k							
Byte data access	S_l		3		2	3 + m		
Word data access	S_m		6		4	6 + 2m		
Internal operation	S_n	1	1	1	1	1	1	1

Legend:

m: Number of wait states inserted into external device access

Table A.4 Number of Cycles per Instruction

Instruction Mnemonic		Instruction	Branch	Stack	Byte Data	Word Data	Internal
		Fetch	Addr. Read	Operation	Access	Access	Operation
		I	J	K	L	M	N
ADD	ADD.B #xx:8, Rd	1					
	ADD.B Rs, Rd	1					
	ADD.W #xx:16, Rd	2					
	ADD.W Rs, Rd	1					
	ADD.L #xx:32, ERd	3					
	ADD.L ERs, ERd	1					
ADDS	ADDS #1/2/4, ERd	1					
ADDX	ADDX #xx:8, Rd	1					
	ADDX Rs, Rd	1					
AND	AND.B #xx:8, Rd	1					
	AND.B Rs, Rd	1					
	AND.W #xx:16, Rd	2					
	AND.W Rs, Rd	1					
	AND.L #xx:32, ERd	3					
	AND.L ERs, ERd	2					
ANDC	ANDC #xx:8, CCR	1					
BAND	BAND #xx:3, Rd	1					
	BAND #xx:3, @ERd	2			1		
	BAND #xx:3, @aa:8	2			1		
Bcc	BRA d:8 (BT d:8)	2					
	BRN d:8 (BF d:8)	2					
	BHI d:8	2					
	BLS d:8	2					
	BCC d:8 (BHS d:8)	2					
	BCS d:8 (BLO d:8)	2					
	BNE d:8	2					
	BEQ d:8	2					
	BVC d:8	2					
	BVS d:8	2					
	BPL d:8	2					
	BMI d:8	2					

Instruction	Mnemonic	Instruction	Branch	Stack	Byte Data	Word Data	Internal
		Fetch	Addr. Read	Operation	Access	Access	Operation
		I	J	K	L	M	N
Bcc	BGE d:8	2					
	BLT d:8	2					
	BGT d:8	2					
	BLE d:8	2					
	BRA d:16 (BT d:16)	2					2
	BRN d:16 (BF d:16)	2					2
	BHI d:16	2					2
	BLS d:16	2					2
	BCC d:16 (BHS d:16)	2					2
	BCS d:16 (BLO d:16)	2					2
	BNE d:16	2					2
	BEQ d:16	2					2
	BVC d:16	2					2
	BVS d:16	2					2
	BPL d:16	2					2
	BMI d:16	2					2
	BGE d:16	2					2
	BLT d:16	2					2
BGT d:16	2					2	
BLE d:16	2					2	
BCLR	BCLR #xx:3, Rd	1					
	BCLR #xx:3, @ERd	2			2		
	BCLR #xx:3, @aa:8	2			2		
	BCLR Rn, Rd	1					
	BCLR Rn, @ERd	2			2		
	BCLR Rn, @aa:8	2			2		
BIAND	BIAND #xx:3, Rd	1					
	BIAND #xx:3, @ERd	2			1		
	BIAND #xx:3, @aa:8	2			1		
BILD	BILD #xx:3, Rd	1					
	BILD #xx:3, @ERd	2			1		
	BILD #xx:3, @aa:8	2			1		

Instruction Mnemonic		Instruction	Branch	Stack	Byte Data	Word Data	Internal	
		Fetch	Addr. Read	Operation	Access	Access	Operation	
		I	J	K	L	M	N	
BIOR	BIOR #xx:8, Rd	1						
	BIOR #xx:8, @ERd	2			1			
	BIOR #xx:8, @aa:8	2			1			
BIST	BIST #xx:3, Rd	1						
	BIST #xx:3, @ERd	2			2			
	BIST #xx:3, @aa:8	2			2			
BIXOR	BIXOR #xx:3, Rd	1						
	BIXOR #xx:3, @ERd	2			1			
	BIXOR #xx:3, @aa:8	2			1			
BLD	BLD #xx:3, Rd	1						
	BLD #xx:3, @ERd	2			1			
	BLD #xx:3, @aa:8	2			1			
BNOT	BNOT #xx:3, Rd	1						
	BNOT #xx:3, @ERd	2			2			
	BNOT #xx:3, @aa:8	2			2			
	BNOT Rn, Rd	1						
	BNOT Rn, @ERd	2			2			
	BNOT Rn, @aa:8	2			2			
BOR	BOR #xx:3, Rd	1						
	BOR #xx:3, @ERd	2			1			
	BOR #xx:3, @aa:8	2			1			
BSET	BSET #xx:3, Rd	1						
	BSET #xx:3, @ERd	2			2			
	BSET #xx:3, @aa:8	2			2			
	BSET Rn, Rd	1						
	BSET Rn, @ERd	2			2			
	BSET Rn, @aa:8	2			2			
BSR	BSR d:8	Normal* ¹	2		1			
		Advanced	2		2			
	BSR d:16	Normal* ¹	2			1		2
		Advanced	2			2		2

Instruction	Mnemonic	Instruction	Branch	Stack	Byte Data	Word Data	Internal
		Fetch	Addr. Read	Operation	Access	Access	Operation
		I	J	K	L	M	N
BST	BST #xx:3, Rd	1					
	BST #xx:3, @ERd	2			2		
	BST #xx:3, @aa:8	2			2		
BTST	BTST #xx:3, Rd	1					
	BTST #xx:3, @ERd	2			1		
	BTST #xx:3, @aa:8	2			1		
	BTST Rn, Rd	1					
	BTST Rn, @ERd	2			1		
	BTST Rn, @aa:8	2			1		
BXOR	BXOR #xx:3, Rd	1					
	BXOR #xx:3, @ERd	2			1		
	BXOR #xx:3, @aa:8	2			1		
CMP	CMP.B #xx:8, Rd	1					
	CMP.B Rs, Rd	1					
	CMP.W #xx:16, Rd	2					
	CMP.W Rs, Rd	1					
	CMP.L #xx:32, ERd	3					
	CMP.L ERs, ERd	1					
DAA	DAA Rd	1					
DAS	DAS Rd	1					
DEC	DEC.B Rd	1					
	DEC.W #1/2, Rd	1					
	DEC.L #1/2, ERd	1					
DIVXS	DIVXS.B Rs, Rd	2					12
	DIVXS.W Rs, ERd	2					20
DIVXU	DIVXU.B Rs, Rd	1					12
	DIVXU.W Rs, ERd	1					20
EEPMOV	EEPMOV.B	2			$2n + 2^{*2}$		
	EEPMOV.W	2			$2n + 2^{*2}$		
EXTS	EXTS.W Rd	1					
	EXTS.L ERd	1					
EXTU	EXTU.W Rd	1					
	EXTU.L ERd	1					

Instruction Mnemonic		Instruction	Branch	Stack	Byte Data	Word Data	Internal	
		Fetch	Addr. Read	Operation	Access	Access	Operation	
		I	J	K	L	M	N	
INC	INC.B Rd	1						
	INC.W #1/2, Rd	1						
	INC.L #1/2, ERd	1						
JMP	JMP @ERn	2						
	JMP @aa:24	2					2	
	JMP @@aa:8	Normal* ¹	2	1				2
		Advanced	2	2				2
JSR	JSR @ERn	Normal* ¹			1			
		Advanced	2		2			
	JSR @aa:24	Normal* ¹	2			1		2
		Advanced	2			2		2
	JSR @@aa:8	Normal* ¹	2	1	1			
		Advanced	2	2	2			
LDC	LDC #xx:8, CCR	1						
	LDC Rs, CCR	1						
	LDC @ERs, CCR	2				1		
	LDC @(d:16, ERs), CCR	3				1		
	LDC @(d:24, ERs), CCR	5				1		
	LDC @ERs+, CCR	2				1	2	
	LDC @aa:16, CCR	3				1		
	LDC @aa:24, CCR	4				1		
MOV	MOV.B #xx:8, Rd	1						
	MOV.B Rs, Rd	1						
	MOV.B @ERs, Rd	1			1			
	MOV.B @(d:16, ERs), Rd	2			1			
	MOV.B @(d:24, ERs), Rd	4			1			
	MOV.B @ERs+, Rd	1			1		2	
	MOV.B @aa:8, Rd	1			1			
	MOV.B @aa:16, Rd	2			1			
	MOV.B @aa:24, Rd	3			1			
	MOV.B Rs, @ERd	1			1			
	MOV.B Rs, @(d:16, ERd)	2			1			

Instruction	Mnemonic	Instruction	Branch	Stack	Byte Data	Word Data	Internal
		Fetch	Addr. Read	Operation	Access	Access	Operation
		I	J	K	L	M	N
MOV	MOV.B Rs, @(d:24, ERd)	4			1		
	MOV.B Rs, @-ERd	1			1		2
	MOV.B Rs, @aa:8	1			1		
	MOV.B Rs, @aa:16	2			1		
	MOV.B Rs, @aa:24	3			1		
	MOV.W #xx:16, Rd	2					
	MOV.W Rs, Rd	1					
	MOV.W @ERs, Rd	1				1	
	MOV.W @(d:16, ERs), Rd	2				1	
	MOV.W @(d:24, ERs), Rd	4				1	
	MOV.W @ERs+, Rd	1				1	2
	MOV.W @aa:16, Rd	2				1	
	MOV.W @aa:24, Rd	3				1	
	MOV.W Rs, @ERd	1				1	
	MOV.W Rs, @(d:16, ERd)	2				1	
	MOV.W Rs, @(d:24, ERd)	4				1	
	MOV.W Rs, @-ERd	1				1	2
	MOV.W Rs, @aa:16	2				1	
	MOV.W Rs, @aa:24	3				1	
	MOV.L #xx:32, ERd	3					
	MOV.L ERs, ERd	1					
	MOV.L @ERs, ERd	2				2	
	MOV.L @(d:16, ERs), ERd	3				2	
	MOV.L @(d:24, ERs), ERd	5				2	
	MOV.L @ERs+, ERd	2				2	2
	MOV.L @aa:16, ERd	3				2	
	MOV.L @aa:24, ERd	4				2	
	MOV.L ERs, @ERd	2				2	
	MOV.L ERs, @(d:16, ERd)	3				2	
	MOV.L ERs, @(d:24, ERd)	5				2	
	MOV.L ERs, @-ERd	2				2	2
	MOV.L ERs, @aa:16	3				2	
	MOV.L ERs, @aa:24	4				2	

Instruction Mnemonic		Instruction	Branch	Stack	Byte Data	Word Data	Internal
		Fetch	Addr. Read	Operation	Access	Access	Operation
		I	J	K	L	M	N
MOVFP	MOVFP @aa:16, Rd ^{*1}	2			1		
MOVTPE	MOVTPE Rs, @aa:16 ^{*1}	2			1		
MULXS	MULXS.B Rs, Rd	2					12
	MULXS.W Rs, ERd	2					20
MULXU	MULXU.B Rs, Rd	1					12
	MULXU.W Rs, ERd	1					20
NEG	NEG.B Rd	1					
	NEG.W Rd	1					
	NEG.L ERd	1					
NOP	NOP	1					
NOT	NOT.B Rd	1					
	NOT.W Rd	1					
	NOT.L ERd	1					
OR	OR.B #xx:8, Rd	1					
	OR.B Rs, Rd	1					
	OR.W #xx:16, Rd	2					
	OR.W Rs, Rd	1					
	OR.L #xx:32, ERd	3					
	OR.L ERs, ERd	2					
ORC	ORC #xx:8, CCR	1					
POP	POP.W Rn	1				1	2
	POP.L ERn	2				2	2
PUSH	PUSH.W Rn	1				1	2
	PUSH.L ERn	2				2	2
ROTL	ROTL.B Rd	1					
	ROTL.W Rd	1					
	ROTL.L ERd	1					
ROTR	ROTR.B Rd	1					
	ROTR.W Rd	1					
	ROTR.L ERd	1					
ROTXL	ROTXL.B Rd	1					
	ROTXL.W Rd	1					
	ROTXL.L ERd	1					

Instruction	Mnemonic	Instruction	Branch	Stack	Byte Data	Word Data	Internal
		Fetch	Addr. Read	Operation	Access	Access	Operation
		I	J	K	L	M	N
ROTXR	ROTXR.B Rd	1					
	ROTXR.W Rd	1					
	ROTXR.L ERd	1					
RTE	RTE	2		2			2
RTS	RTS	Normal ^{*1}		1			2
		Advanced		2			2
SHAL	SHAL.B Rd	1					
	SHAL.W Rd	1					
	SHAL.L ERd	1					
SHAR	SHAR.B Rd	1					
	SHAR.W Rd	1					
	SHAR.L ERd	1					
SHLL	SHLL.B Rd	1					
	SHLL.W Rd	1					
	SHLL.L ERd	1					
SHLR	SHLR.B Rd	1					
	SHLR.W Rd	1					
	SHLR.L ERd	1					
SLEEP	SLEEP	1					
STC	STC CCR, Rd	1					
	STC CCR, @ERd	2				1	
	STC CCR, @(d:16, ERd)	3				1	
	STC CCR, @(d:24, ERd)	5				1	
	STC CCR, @-ERd	2				1	2
	STC CCR, @aa:16	3				1	
	STC CCR, @aa:24	4				1	
SUB	SUB.B Rs, Rd	1					
	SUB.W #xx:16, Rd	2					
	SUB.W Rs, Rd	1					
	SUB.L #xx:32, ERd	3					
	SUB.L ERs, ERd	1					
SUBS	SUBS #1/2/4, ERd	1					

Instruction Mnemonic		Instruction Fetch	Branch Addr. Read	Stack Operation	Byte Data Access	Word Data Access	Internal Operation
		I	J	K	L	M	N
SUBX	SUBX #xx:8, Rd	1					
	SUBX Rs, Rd	1					
TRAPA	TRAPA #x:2	Normal ^{*1}	2	1	2		4
		Advanced	2	2	2		4
XOR	XOR.B #xx:8, Rd	1					
	XOR.B Rs, Rd	1					
	XOR.W #xx:16, Rd	2					
	XOR.W Rs, Rd	1					
	XOR.L #xx:32, ERd	3					
	XOR.L ERs, ERd	2					
XORC	XORC #xx:8, CCR	1					

- Notes:
1. Not available in the H8/3048B Group.
 2. n is the value set in register R4L or R4. The source and destination are accessed n + 1 times each.

Appendix B Internal I/O Register

Table B.1 Comparison of H8/3048 Group and H8/3048B Group Internal I/O Register Specifications

Address (Low)	H8/3048 ZTAT	H8/3048 Mask ROM Version, H8/3047 Mask ROM Version, H8/3045 Mask ROM Version, H8/3044 Mask ROM Version	H8/3048F	H8/3048 F-ONE	H8/3048B Mask ROM Version	Module
H'FF40	—	—	FLMCR	FLMCR1	—	Flash memory
H'FF41	—	—	—	FLMCR2	—	
H'FF42	—	—	EBR1	EBR	—	
H'FF43	—	—	EBR2	—	—	
H'FF47	—	—	—	RAMCR	—	
H'FF48	—	—	RAMCR	—	—	

Note: A dash (“—”) indicates that access is prohibited. Normal operation is not guaranteed if these addresses are accessed.

B.1 Addresses (For H8/3048F-ONE, H8/3048B Mask ROM Version)

Address (low)	Register Name	Data Bus Width	Bit Names								Module Name
			Bit 7	Bit 6	Bit 5	Bit 4	Bit 3	Bit 2	Bit 1	Bit 0	
H'1C	Reserved area (access prohibited)										
H'1D											
H'1E											
H'1F											
H'20	MAR0AR	8									DMAC
H'21	MAR0AE	8									channel 0A
H'22	MAR0AH	8									
H'23	MAR0AL	8									
H'24	ETCR0AH	8									
H'25	ETCR0AL	8									
H'26	IOAR0A	8									
H'27	DTCR0A	8	DTE	DTSZ	DTID	RPE	DTIE	DTS2	DTS1	DTS0	Short address mode
			DTE	DTSZ	SAID	SAIDE	DTIE	DTS2A	DTS1A	DTS0A	Full address mode
H'28	MAR0BR	8									DMAC channel 0B
H'29	MAR0BE	8									
H'2A	MAR0BH	8									
H'2B	MAR0BL	8									
H'2C	ETCR0BH	8									
H'2D	ETCR0BL	8									
H'2E	IOAR0B	8									
H'2F	DTCR0B	8	DTE	DTSZ	DTID	RPE	DTIE	DTS2	DTS1	DTS0	Short address mode
			DTME	—	DAID	DAIDE	TMS	DTS2B	DTS1B	DTS0B	Full address mode

Address (low)	Register Name	Data Bus Width	Bit Names								Module Name
			Bit 7	Bit 6	Bit 5	Bit 4	Bit 3	Bit 2	Bit 1	Bit 0	
H'30	MAR1AR	8									DMAC channel 1A
H'31	MAR1AE	8									
H'32	MAR1AH	8									
H'33	MAR1AL	8									
H'34	ETCR1AH	8									
H'35	ETCR1AL	8									
H'36	IOAR1A	8									
H'37	DTCR1A	8	DTE	DTSZ	DTID	RPE	DTIE	DTS2	DTS1	DTS0	Short address mode
			DTE	DTSZ	SAID	SAIDE	DTIE	DTS2A	DTS1A	DTS0A	Full address mode
H'38	MAR1BR	8									DMAC channel 1B
H'39	MAR1BE	8									
H'3A	MAR1BH	8									
H'3B	MAR1BL	8									
H'3C	ETCR1BH	8									
H'3D	ETCR1BL	8									
H'3E	IOAR1B	8									
H'3F	DTCR1B	8	DTE	DTSZ	DTID	RPE	DTIE	DTS2	DTS1	DTS0	Short address mode
			DTME	—	DAID	DAIDE	TMS	DTS2B	DTS1B	DTS0B	Full address mode
H'40	FLMCR1*4	8	FWE	SWE	ESU	PSU	EV	PV	E	P	Flash memory
H'41	FLMCR2*4	8	FLER	—*3	—*3	—*3	—*3	—*3	—*3	—*3	
H'42	EBR*4	8	EB7	EB6	EB5	EB4	EB3	EB2	EB1	EB0	
H'43	Reserved area (access prohibited)										
H'44											
H'45											
H'46											
H'47	RAMCR*4	8	—	—	—	—	RAMS	RAM2	RAM1	—	
H'48	Reserved area (access prohibited)										
H'49											
H'4A											
H'4B											
H'4C											
H'4D											
H'4E											
H'4F											

Address (low)	Register Name	Data Bus Width	Bit Names								Module Name
			Bit 7	Bit 6	Bit 5	Bit 4	Bit 3	Bit 2	Bit 1	Bit 0	
H'50	Reserved area (access prohibited)										
H'51											
H'52											
H'53											
H'54											
H'55											
H'56											
H'57											
H'58											
H'59											
H'5A											
H'5B											
H'5C	DASTCR	8	—	—	—	—	—	—	—	DASTE	D/A converter
H'5D	DIVCR	8	—	—	—	—	—	—	DIV1	DIV0	System control
H'5E	MSTCR	8	PSTOP	—	MSTOP5	MSTOP4	MSTOP3	MSTOP2	MSTOP1	MSTOP0	
H'5F	CSCCR	8	CS7E	CS6E	CS5E	CS4E	—	—	—	—	Bus controller
H'60	TSTR	8	—	—	—	STR4	STR3	STR2	STR1	STR0	ITU (all channels)
H'61	TSNC	8	—	—	—	SYNC4	SYNC3	SYNC2	SYNC1	SYNC0	
H'62	TMDR	8	—	MDF	FDIR	PWM4	PWM3	PWM2	PWM1	PWM0	
H'63	TFCR	8	—	—	CMD1	CMD0	BFB4	BFA4	BFB3	BFA3	
H'64	TCR0	8	—	CCLR1	CCLR0	CKEG1	CKEG0	TPSC2	TPSC1	TPSC0	ITU channel 0
H'65	TIOR0	8	—	IOB2	IOB1	IOB0	—	IOA2	IOA1	IOA0	
H'66	TIER0	8	—	—	—	—	—	OVIE	IMIEB	IMIEA	
H'67	TSR0	8	—	—	—	—	—	OVF	IMFB	IMFA	
H'68	TCNT0H	16									
H'69	TCNT0L										
H'6A	GRA0H	16									
H'6B	GRA0L										
H'6C	GRB0H	16									
H'6D	GRB0L										
H'6E	TCR1	8	—	CCLR1	CCLR0	CKEG1	CKEG0	TPSC2	TPSC1	TPSC0	ITU channel 1
H'6F	TIOR1	8	—	IOB2	IOB1	IOB0	—	IOA2	IOA1	IOA0	

Address (low)	Register Name	Data Bus Width	Bit Names								Module Name
			Bit 7	Bit 6	Bit 5	Bit 4	Bit 3	Bit 2	Bit 1	Bit 0	
H'70	TIER1	8	—	—	—	—	—	OVIE	IMIEB	IMIEA	ITU channel 1
H'71	TSR1	8	—	—	—	—	—	OVF	IMFB	IMFA	
H'72	TCNT1H	16									
H'73	TCNT1L										
H'74	GRA1H	16									
H'75	GRA1L										
H'76	GRB1H	16									
H'77	GRB1L										
H'78	TCR2	8	—	CCLR1	CCLR0	CKEG1	CKEG0	TPSC2	TPSC1	TPSC0	ITU channel 2
H'79	TIOR2	8	—	IOB2	IOB1	IOB0	—	IOA2	IOA1	IOA0	
H'7A	TIER2	8	—	—	—	—	—	OVIE	IMIEB	IMIEA	
H'7B	TSR2	8	—	—	—	—	—	OVF	IMFB	IMFA	
H'7C	TCNT2H	16									
H'7D	TCNT2L										
H'7E	GRA2H	16									
H'7F	GRA2L										
H'80	GRB2H	16									
H'81	GRB2L										
H'82	TCR3	8	—	CCLR1	CCLR0	CKEG1	CKEG0	TPSC2	TPSC1	TPSC0	ITU channel 3
H'83	TIOR3	8	—	IOB2	IOB1	IOB0	—	IOA2	IOA1	IOA0	
H'84	TIER3	8	—	—	—	—	—	OVIE	IMIEB	IMIEA	
H'85	TSR3	8	—	—	—	—	—	OVF	IMFB	IMFA	
H'86	TCNT3H	16									
H'87	TCNT3L										
H'88	GRA3H	16									
H'89	GRA3L										
H'8A	GRB3H	16									
H'8B	GRB3L										
H'8C	BRA3H	16									
H'8D	BRA3L										
H'8E	BRB3H	16									
H'8F	BRB3L										

Address (low)	Register Name	Data Bus Width	Bit Names								Module Name
			Bit 7	Bit 6	Bit 5	Bit 4	Bit 3	Bit 2	Bit 1	Bit 0	
H'90	TOER	8	—	—	EXB4	EXA4	EB3	EB4	EA4	EA3	ITU (all channels)
H'91	TOCR	8	—	—	—	XTGD	—	—	OLS4	OLS3	
H'92	TCR4	8	—	CCLR1	CCLR0	CKEG1	CKEG0	TPSC2	TPSC1	TPSC0	ITU channel 4
H'93	TIOR4	8	—	IOB2	IOB1	IOB0	—	IOA2	IOA1	IOA0	
H'94	TIER4	8	—	—	—	—	—	OVIE	IMIEB	IMIEA	
H'95	TSR4	8	—	—	—	—	—	OVF	IMFB	IMFA	
H'96	TCNT4H	16									
H'97	TCNT4L										
H'98	GRA4H	16									
H'99	GRA4L										
H'9A	GRB4H	16									
H'9B	GRB4L										
H'9C	BRA4H	16									
H'9D	BRA4L										
H'9E	BRB4H	16									
H'9F	BRB4L										
H'A0	TPMR	8	—	—	—	—	G3NOV	G2NOV	G1NOV	G0NOV	TPC
H'A1	TPCR	8	G3CMS1	G3CMS0	G2CMS1	G2CMS0	G1CMS1	G1CMS0	G0CMS1	G0CMS0	
H'A2	NDERB	8	NDER15	NDER14	NDER13	NDER12	NDER11	NDER10	NDER9	NDER8	
H'A3	NDERA	8	NDER7	NDER6	NDER5	NDER4	NDER3	NDER2	NDER1	NDER0	
H'A4	NDRB ^{*1}	8	NDR15	NDR14	NDR13	NDR12	NDR11	NDR10	NDR9	NDR8	
		8	NDR15	NDR14	NDR13	NDR12	—	—	—	—	
H'A5	NDRA ^{*1}	8	NDR7	NDR6	NDR5	NDR4	NDR3	NDR2	NDR1	NDR0	
		8	NDR7	NDR6	NDR5	NDR4	—	—	—	—	
H'A6	NDRB ^{*1}	8	—	—	—	—	—	—	—	—	
		8	—	—	—	—	NDR11	NDR10	NDR9	NDR8	
H'A7	NDRA ^{*1}	8	—	—	—	—	—	—	—	—	
		8	—	—	—	—	NDR3	NDR2	NDR1	NDR0	
H'A8	TCSR ^{*2}	8	OVF	WT/IT	TME	—	—	CKS2	CKS1	CKS0	WDT
H'A9	TCNT ^{*2}	8									
H'AA	—		—	—	—	—	—	—	—	—	
H'AB	RSTCSR ^{*2}	8	WRST	—	—	—	—	—	—	—	
H'AC	RFSHCR	8	SRFMD	PSRAME	DRAME	CAS/WE	M9/M8	RFSHE	—	RCYCE	Refresh controller
H'AD	RTMCSR	8	CMF	CMIE	CKS2	CKS1	CKS0	—	—	—	
H'AE	RTCNT	8									
H'AF	RTCOR	8									

Appendix B Internal I/O Register

Address (low)	Register Name	Data Bus Width	Bit Names								Module Name
			Bit 7	Bit 6	Bit 5	Bit 4	Bit 3	Bit 2	Bit 1	Bit 0	
H'B0	SMR	8	C \bar{A} /GM	CHR	PE	O \bar{E}	STOP	MP	CKS1	CKS0	SCI channel 0
H'B1	BRR	8									
H'B2	SCR	8	TIE	RIE	TE	RE	MPIE	TEIE	CKE1	CKE0	
H'B3	TDR	8									
H'B4	SSR	8	TDRE	RDRF	ORER	FER/ERS	PER	TEND	MPB	MPBT	
H'B5	RDR	8									
H'B6	SCMR	8	—	—	—	—	SDIR	SINV	—	SMIF	
H'B7	Reserved area (access prohibited)										
H'B8	SMR	8	C \bar{A}	CHR	PE	O \bar{E}	STOP	MP	CKS1	CKS0	SCI channel 1
H'B9	BRR	8									
H'BA	SCR	8	TIE	RIE	TE	RE	MPIE	TEIE	CKE1	CKE0	
H'BB	TDR	8									
H'BC	SSR	8	TDRE	RDRF	ORER	FER	PER	TEND	MPB	MPBT	
H'BD	RDR	8									
H'BE	Reserved area (access prohibited)										
H'BF											
H'C0	P1DDR	8	P1 ₇ DDR	P1 ₆ DDR	P1 ₅ DDR	P1 ₄ DDR	P1 ₃ DDR	P1 ₂ DDR	P1 ₁ DDR	P1 ₀ DDR	Port 1
H'C1	P2DDR	8	P2 ₇ DDR	P2 ₆ DDR	P2 ₅ DDR	P2 ₄ DDR	P2 ₃ DDR	P2 ₂ DDR	P2 ₁ DDR	P2 ₀ DDR	Port 2
H'C2	P1DR	8	P1 ₇	P1 ₆	P1 ₅	P1 ₄	P1 ₃	P1 ₂	P1 ₁	P1 ₀	Port 1
H'C3	P2DR	8	P2 ₇	P2 ₆	P2 ₅	P2 ₄	P2 ₃	P2 ₂	P2 ₁	P2 ₀	Port 2
H'C4	P3DDR	8	P3 ₇ DDR	P3 ₆ DDR	P3 ₅ DDR	P3 ₄ DDR	P3 ₃ DDR	P3 ₂ DDR	P3 ₁ DDR	P3 ₀ DDR	Port 3
H'C5	P4DDR	8	P4 ₇ DDR	P4 ₆ DDR	P4 ₅ DDR	P4 ₄ DDR	P4 ₃ DDR	P4 ₂ DDR	P4 ₁ DDR	P4 ₀ DDR	Port 4
H'C6	P3DR	8	P3 ₇	P3 ₆	P3 ₅	P3 ₄	P3 ₃	P3 ₂	P3 ₁	P3 ₀	Port 3
H'C7	P4DR	8	P4 ₇	P4 ₆	P4 ₅	P4 ₄	P4 ₃	P4 ₂	P4 ₁	P4 ₀	Port 4
H'C8	P5DDR	8	—	—	—	—	P5 ₃ DDR	P5 ₂ DDR	P5 ₁ DDR	P5 ₀ DDR	Port 5
H'C9	P6DDR	8	—	P6 ₆ DDR	P6 ₅ DDR	P6 ₄ DDR	P6 ₃ DDR	P6 ₂ DDR	P6 ₁ DDR	P6 ₀ DDR	Port 6
H'CA	P5DR	8	—	—	—	—	P5 ₃	P5 ₂	P5 ₁	P5 ₀	Port 5
H'CB	P6DR	8	—	P6 ₆	P6 ₅	P6 ₄	P6 ₃	P6 ₂	P6 ₁	P6 ₀	Port 6
H'CC	—	—	—	—	—	—	—	—	—	—	—
H'CD	P8DDR	8	—	—	—	P8 ₄ DDR	P8 ₃ DDR	P8 ₂ DDR	P8 ₁ DDR	P8 ₀ DDR	Port 8
H'CE	P7DR	8	P7 ₇	P7 ₆	P7 ₅	P7 ₄	P7 ₃	P7 ₂	P7 ₁	P7 ₀	Port 7
H'CF	P8DR	8	—	—	—	P8 ₄	P8 ₃	P8 ₂	P8 ₁	P8 ₀	Port 8

Address (low)	Register Name	Data Bus Width	Bit Names								Module Name
			Bit 7	Bit 6	Bit 5	Bit 4	Bit 3	Bit 2	Bit 1	Bit 0	
H'D0	P9DDR	8	—	—	P9 ₅ DDR	P9 ₄ DDR	P9 ₃ DDR	P9 ₂ DDR	P9 ₁ DDR	P9 ₀ DDR	Port 9
H'D1	PADDR	8	PA ₇ DDR	PA ₆ DDR	PA ₅ DDR	PA ₄ DDR	PA ₃ DDR	PA ₂ DDR	PA ₁ DDR	PA ₀ DDR	Port A
H'D2	P9DR	8	—	—	P9 ₅	P9 ₄	P9 ₃	P9 ₂	P9 ₁	P9 ₀	Port 9
H'D3	PADR	8	PA ₇	PA ₆	PA ₅	PA ₄	PA ₃	PA ₂	PA ₁	PA ₀	Port A
H'D4	PBDDR	8	PB ₇ DDR	PB ₆ DDR	PB ₅ DDR	PB ₄ DDR	PB ₃ DDR	PB ₂ DDR	PB ₁ DDR	PB ₀ DDR	Port B
H'D5	—	—	—	—	—	—	—	—	—	—	—
H'D6	PBDR	8	PB ₇	PB ₆	PB ₅	PB ₄	PB ₃	PB ₂	PB ₁	PB ₀	Port B
H'D7	—	—	—	—	—	—	—	—	—	—	—
H'D8	P2PCR	8	P2 ₇ PCR	P2 ₆ PCR	P2 ₅ PCR	P2 ₄ PCR	P2 ₃ PCR	P2 ₂ PCR	P2 ₁ PCR	P2 ₀ PCR	Port 2
H'D9	—	—	—	—	—	—	—	—	—	—	—
H'DA	P4PCR	8	P4 ₇ PCR	P4 ₆ PCR	P4 ₅ PCR	P4 ₄ PCR	P4 ₃ PCR	P4 ₂ PCR	P4 ₁ PCR	P4 ₀ PCR	Port 4
H'DB	P5PCR	8	—	—	—	—	P5 ₃ PCR	P5 ₂ PCR	P5 ₁ PCR	P5 ₀ PCR	Port 5
H'DC	DADR0	8									D/A converter
H'DD	DADR1	8									
H'DE	DACR	8	DAOE1	DAOE0	DAE	—	—	—	—	—	
H'DF	Reserved area (access prohibited)										
H'E0	ADDRAH	8	AD9	AD8	AD7	AD6	AD5	AD4	AD3	AD2	A/D converter
H'E1	ADDRAL	8	AD1	AD0	—	—	—	—	—	—	
H'E2	ADDRBH	8	AD9	AD8	AD7	AD6	AD5	AD4	AD3	AD2	
H'E3	ADDRBL	8	AD1	AD0	—	—	—	—	—	—	
H'E4	ADDRCH	8	AD9	AD8	AD7	AD6	AD5	AD4	AD3	AD2	
H'E5	ADDRCL	8	AD1	AD0	—	—	—	—	—	—	
H'E6	ADDRDH	8	AD9	AD8	AD7	AD6	AD5	AD4	AD3	AD2	
H'E7	ADDRDL	8	AD1	AD0	—	—	—	—	—	—	
H'E8	ADCSR	8	ADF	ADIE	ADST	SCAN	CKS	CH2	CH1	CH0	
H'E9	ADCR	8	TRGE	—	—	—	—	—	—	—	
H'EA	Reserved area (access prohibited)										
H'EB											
H'EC	ABWCR	8	ABW7	ABW6	ABW5	ABW4	ABW3	ABW2	ABW1	ABW0	Bus controller
H'ED	ASTCR	8	AST7	AST6	AST5	AST4	AST3	AST2	AST1	AST0	
H'EE	WCR	8	—	—	—	—	WMS1	WMS0	WC1	WC0	
H'EF	WCER	8	WCE7	WCE6	WCE5	WCE4	WCE3	WCE2	WCE1	WCE0	

Address (low)	Register Name	Data Bus Width	Bit Names								Module Name
			Bit 7	Bit 6	Bit 5	Bit 4	Bit 3	Bit 2	Bit 1	Bit 0	
H'F0	Reserved area (access prohibited)										
H'F1	MDCR	8	—	—	—	—	—	MDS2	MDS1	MDS0	System control
H'F2	SYSCR	8	SSBY	STS2	STS1	STS0	UE	NMIEG	—	RAME	
H'F3	BRCR	8	A23E	A22E	A21E	—	—	—	—	BRLE	Bus controller
H'F4	ISCR	8	—	—	IRQ5SC	IRQ4SC	IRQ3SC	IRQ2SC	IRQ1SC	IRQ0SC	Interrupt controller
H'F5	IER	8	—	—	IRQ5E	IRQ4E	IRQ3E	IRQ2E	IRQ1E	IRQ0E	
H'F6	ISR	8	—	—	IRQ5F	IRQ4F	IRQ3F	IRQ2F	IRQ1F	IRQ0F	
H'F7	Reserved area (access prohibited)										
H'F8	IPRA	8	IPRA7	IPRA6	IPRA5	IPRA4	IPRA3	IPRA2	IPRA1	IPRA0	
H'F9	IPRB	8	IPRB7	IPRB6	IPRB5	—	IPRB3	IPRB2	IPRB1	—	
H'FA	Reserved area (access prohibited)										
H'FB											
H'FC											
H'FD											
H'FE											
H'FF											

Legend:

DMAC: DMA controller

ITU: 16-bit integrated timer unit

TPC: Programmable timing pattern controller

WDT: Watchdog timer

SCI: Serial communication interface

- Notes:
1. The address depends on the output trigger setting.
 2. For write access to TCSR TCNT, and RSTCR see section 12.2.4, Notes on Register Rewriting.
 3. Bits 6 to 0 in FLMCR2 are reserved bits but are readable/writable.
 4. Byte data must be used to access FLMCR1, FLMCR2, EBR, and RAMCR. Registers FLMCR1, FLMCR2, EBR, and RAMCR are implemented in the flash memory version only. The mask ROM version does not have these registers.

B.2 Addresses (For H8/3048F, H8/3048ZTAT, H8/3048 Mask-ROM, H8/3047 Mask-ROM, H8/3045 Mask-ROM, and H8/3044 Mask-ROM Versions)

Address (low)	Register Name	Data Bus Width	Bit Names								Module Name
			Bit 7	Bit 6	Bit 5	Bit 4	Bit 3	Bit 2	Bit 1	Bit 0	
H'1C											
H'1D											
H'1E											
H'1F											
H'20	MAR0AR	8									DMAC
H'21	MAR0AE	8									channel 0A
H'22	MAR0AH	8									
H'23	MAR0AL	8									
H'24	ETCR0AH	8									
H'25	ETCR0AL	8									
H'26	IOAR0A	8									
H'27	DTCR0A	8	DTE	DTSZ	DTID	RPE	DTIE	DTS2	DTS1	DTS0	Short address mode
			DTE	DTSZ	SAID	SAIDE	DTIE	DTS2A	DTS1A	DTS0A	Full address mode
H'28	MAR0BR	8									DMAC
H'29	MAR0BE	8									channel 0B
H'2A	MAR0BH	8									
H'2B	MAR0BL	8									
H'2C	ETCR0BH	8									
H'2D	ETCR0BL	8									
H'2E	IOAR0B	8									
H'2F	DTCR0B	8	DTE	DTSZ	DTID	RPE	DTIE	DTS2	DTS1	DTS0	Short address mode
			DTME	—	DAID	DAIDE	TMS	DTS2B	DTS1B	DTS0B	Full address mode

Address (low)	Register Name	Data Bus Width	Bit Names								Module Name
			Bit 7	Bit 6	Bit 5	Bit 4	Bit 3	Bit 2	Bit 1	Bit 0	
H'30	MAR1AR	8									DMAC channel 1A
H'31	MAR1AE	8									
H'32	MAR1AH	8									
H'33	MAR1AL	8									
H'34	ETCR1AH	8									
H'35	ETCR1AL	8									
H'36	IOAR1A	8									
H'37	DTCR1A	8	DTE	DTSZ	DTID	RPE	DTIE	DTS2	DTS1	DTS0	Short address mode
			DTE	DTSZ	SAID	SAIDE	DTIE	DTS2A	DTS1A	DTS0A	Full address mode
H'38	MAR1BR	8									DMAC channel 1B
H'39	MAR1BE	8									
H'3A	MAR1BH	8									
H'3B	MAR1BL	8									
H'3C	ETCR1BH	8									
H'3D	ETCR1BL	8									
H'3E	IOAR1B	8									
H'3F	DTCR1B	8	DTE	DTSZ	DTID	RPE	DTIE	DTS2	DTS1	DTS0	Short address mode
			DTME	—	DAID	DAIDE	TMS	DTS2B	DTS1B	DTS0B	Full address mode
H'40	FLMCR	8	V _{PP}	V _{PP} E	—	—	EV	PV	E	P	Flash memory
H'41	—	—	—	—	—	—	—	—	—	—	
H'42	EBR1	8	LB7	LB6	LB5	LB4	LB3	LB2	LB1	LB0	
H'43	EBR2	8	SB7	SB6	SB5	SB4	SB3	SB2	SB1	SB0	
H'44	—	—	—	—	—	—	—	—	—	—	
H'45	—	—	—	—	—	—	—	—	—	—	
H'46	—	—	—	—	—	—	—	—	—	—	
H'47	—	—	—	—	—	—	—	—	—	—	
H'48	RAMCR	8	FLER	—	—	—	RAMS	RAM2	RAM1	RAM0	
H'49	—	—	—	—	—	—	—	—	—	—	
H'4A	—	—	—	—	—	—	—	—	—	—	
H'4B	—	—	—	—	—	—	—	—	—	—	
H'4C	—	—	—	—	—	—	—	—	—	—	
H'4D	—	—	—	—	—	—	—	—	—	—	
H'4E	—	—	—	—	—	—	—	—	—	—	
H'4F	—	—	—	—	—	—	—	—	—	—	

Address (low)	Register Name	Data Bus Width	Bit Names								Module Name	
			Bit 7	Bit 6	Bit 5	Bit 4	Bit 3	Bit 2	Bit 1	Bit 0		
H'50	—	—	—	—	—	—	—	—	—	—	—	
H'51	—	—	—	—	—	—	—	—	—	—	—	
H'52	—	—	—	—	—	—	—	—	—	—	—	
H'53	—	—	—	—	—	—	—	—	—	—	—	
H'54	—	—	—	—	—	—	—	—	—	—	—	
H'55	—	—	—	—	—	—	—	—	—	—	—	
H'56	—	—	—	—	—	—	—	—	—	—	—	
H'57	—	—	—	—	—	—	—	—	—	—	—	
H'58	—	—	—	—	—	—	—	—	—	—	—	
H'59	—	—	—	—	—	—	—	—	—	—	—	
H'5A	—	—	—	—	—	—	—	—	—	—	—	
H'5B	—	—	—	—	—	—	—	—	—	—	—	
H'5C	DASTCR	8	—	—	—	—	—	—	—	—	DASTE	D/A converter
H'5D	DIVCR	8	—	—	—	—	—	—	—	DIV1	DIV0	System control
H'5E	MSTCR	8	PSTOP	—	MSTOP5	MSTOP4	MSTOP3	MSTOP2	MSTOP1	MSTOP0	—	—
H'5F	CSCCR	8	CS7E	CS6E	CS5E	CS4E	—	—	—	—	—	Bus controller
H'60	TSTR	8	—	—	—	STR4	STR3	STR2	STR1	STR0	—	ITU
H'61	TSNC	8	—	—	—	SYNC4	SYNC3	SYNC2	SYNC1	SYNC0	—	(all channels)
H'62	TMDR	8	—	MDF	FDIR	PWM4	PWM3	PWM2	PWM1	PWM0	—	—
H'63	TFCR	8	—	—	CMD1	CMD0	BFB4	BFA4	BFB3	BFA3	—	—
H'64	TCR0	8	—	CCLR1	CCLR0	CKEG1	CKEG0	TPSC2	TPSC1	TPSC0	—	ITU channel 0
H'65	TIOR0	8	—	IOB2	IOB1	IOB0	—	IOA2	IOA1	IOA0	—	—
H'66	TIER0	8	—	—	—	—	—	OVIE	IMIEB	IMIEA	—	—
H'67	TSR0	8	—	—	—	—	—	OVF	IMFB	IMFA	—	—
H'68	TCNT0H	16	—	—	—	—	—	—	—	—	—	—
H'69	TCNT0L	—	—	—	—	—	—	—	—	—	—	—
H'6A	GRA0H	16	—	—	—	—	—	—	—	—	—	—
H'6B	GRA0L	—	—	—	—	—	—	—	—	—	—	—
H'6C	GRB0H	16	—	—	—	—	—	—	—	—	—	—
H'6D	GRB0L	—	—	—	—	—	—	—	—	—	—	—
H'6E	TCR1	8	—	CCLR1	CCLR0	CKEG1	CKEG0	TPSC2	TPSC1	TPSC0	—	ITU channel 1
H'6F	TIOR1	8	—	IOB2	IOB1	IOB0	—	IOA2	IOA1	IOA0	—	—

Address (low)	Register Name	Data Bus Width	Bit Names								Module Name
			Bit 7	Bit 6	Bit 5	Bit 4	Bit 3	Bit 2	Bit 1	Bit 0	
H'70	TIER1	8	—	—	—	—	—	OVIE	IMIEB	IMIEA	ITU channel 1
H'71	TSR1	8	—	—	—	—	—	OVF	IMFB	IMFA	
H'72	TCNT1H	16									
H'73	TCNT1L										
H'74	GRA1H	16									
H'75	GRA1L										
H'76	GRB1H	16									
H'77	GRB1L										
H'78	TCR2	8	—	CCLR1	CCLR0	CKEG1	CKEG0	TPSC2	TPSC1	TPSC0	ITU channel 2
H'79	TIOR2	8	—	IOB2	IOB1	IOB0	—	IOA2	IOA1	IOA0	
H'7A	TIER2	8	—	—	—	—	—	OVIE	IMIEB	IMIEA	
H'7B	TSR2	8	—	—	—	—	—	OVF	IMFB	IMFA	
H'7C	TCNT2H	16									
H'7D	TCNT2L										
H'7E	GRA2H	16									
H'7F	GRA2L										
H'80	GRB2H	16									
H'81	GRB2L										
H'82	TCR3	8	—	CCLR1	CCLR0	CKEG1	CKEG0	TPSC2	TPSC1	TPSC0	ITU channel 3
H'83	TIOR3	8	—	IOB2	IOB1	IOB0	—	IOA2	IOA1	IOA0	
H'84	TIER3	8	—	—	—	—	—	OVIE	IMIEB	IMIEA	
H'85	TSR3	8	—	—	—	—	—	OVF	IMFB	IMFA	
H'86	TCNT3H	16									
H'87	TCNT3L										
H'88	GRA3H	16									
H'89	GRA3L										
H'8A	GRB3H	16									
H'8B	GRB3L										
H'8C	BRA3H	16									
H'8D	BRA3L										
H'8E	BRB3H	16									
H'8F	BRB3L										

Address (low)	Register Name	Data Bus Width	Bit Names								Module Name
			Bit 7	Bit 6	Bit 5	Bit 4	Bit 3	Bit 2	Bit 1	Bit 0	
H'90	TOER	8	—	—	EXB4	EXA4	EB3	EB4	EA4	EA3	ITU (all channels)
H'91	TOCR	8	—	—	—	XTGD	—	—	OLS4	OLS3	
H'92	TCR4	8	—	CCLR1	CCLR0	CKEG1	CKEG0	TPSC2	TPSC1	TPSC0	ITU channel 4
H'93	TIOR4	8	—	IOB2	IOB1	IOB0	—	IOA2	IOA1	IOA0	
H'94	TIER4	8	—	—	—	—	—	OVIE	IMIEB	IMIEA	
H'95	TSR4	8	—	—	—	—	—	OVF	IMFB	IMFA	
H'96	TCNT4H	16									
H'97	TCNT4L										
H'98	GRA4H	16									
H'99	GRA4L										
H'9A	GRB4H	16									
H'9B	GRB4L										
H'9C	BRA4H	16									
H'9D	BRA4L										
H'9E	BRB4H	16									
H'9F	BRB4L										
H'A0	TPMR	8	—	—	—	—	G3NOV	G2NOV	G1NOV	G0NOV	TPC
H'A1	TPCR	8	G3CMS1	G3CMS0	G2CMS1	G2CMS0	G1CMS1	G1CMS0	G0CMS1	G0CMS0	
H'A2	NDERB	8	NDER15	NDER14	NDER13	NDER12	NDER11	NDER10	NDER9	NDER8	
H'A3	NDERA	8	NDER7	NDER6	NDER5	NDER4	NDER3	NDER2	NDER1	NDER0	
H'A4	NDRB ^{*1}	8	NDR15	NDR14	NDR13	NDR12	NDR11	NDR10	NDR9	NDR8	
		8	NDR15	NDR14	NDR13	NDR12	—	—	—	—	
H'A5	NDRA ^{*1}	8	NDR7	NDR6	NDR5	NDR4	NDR3	NDR2	NDR1	NDR0	
		8	NDR7	NDR6	NDR5	NDR4	—	—	—	—	
H'A6	NDRB ^{*1}	8	—	—	—	—	—	—	—	—	
		8	—	—	—	—	NDR11	NDR10	NDR9	NDR8	
H'A7	NDRA ^{*1}	8	—	—	—	—	—	—	—	—	
		8	—	—	—	—	NDR3	NDR2	NDR1	NDR0	
H'A8	TCSR ^{*2}	8	OVF	WT/IT	TME	—	—	CKS2	CKS1	CKS0	WDT
H'A9	TCNT ^{*2}	8									
H'AA	—		—	—	—	—	—	—	—	—	
H'AB	RSTCSR ^{*2}	8	WRST	RSTOE	—	—	—	—	—	—	
H'AC	RFSHCR	8	SRFMD	PSRAME	DRAME	CAS/WE	M9/M8	RFSHE	—	RCYCE	Refresh controller
H'AD	RTMCSR	8	CMF	CMIE	CKS2	CKS1	CKS0	—	—	—	
H'AE	RTCNT	8									
H'AF	RTCOR	8									

Appendix B Internal I/O Register

Address (low)	Register Name	Data Bus Width	Bit Names								Module Name
			Bit 7	Bit 6	Bit 5	Bit 4	Bit 3	Bit 2	Bit 1	Bit 0	
H'B0	SMR	8	C \bar{A} /GM	CHR	PE	O \bar{E}	STOP	MP	CKS1	CKS0	SCI channel 0
H'B1	BRR	8									
H'B2	SCR	8	TIE	RIE	TE	RE	MPIE	TEIE	CKE1	CKE0	
H'B3	TDR	8									
H'B4	SSR	8	TDRE	RDRF	ORER	FER/ ERS	PER	TEND	MPB	MPBT	
H'B5	RDR	8									
H'B6	SCMR	8	—	—	—	—	SDIR	SINV	—	SMIF	
H'B7											
H'B8	SMR	8	C \bar{A}	CHR	PE	O \bar{E}	STOP	MP	CKS1	CKS0	SCI channel 1
H'B9	BRR	8									
H'BA	SCR	8	TIE	RIE	TE	RE	MPIE	TEIE	CKE1	CKE0	
H'BB	TDR	8									
H'BC	SSR	8	TDRE	RDRF	ORER	FER	PER	TEND	MPB	MPBT	
H'BD	RDR	8									
H'BE	—		—	—	—	—	—	—	—	—	
H'BF											
H'C0	P1DDR	8	P1 ₇ DDR	P1 ₆ DDR	P1 ₅ DDR	P1 ₄ DDR	P1 ₃ DDR	P1 ₂ DDR	P1 ₁ DDR	P1 ₀ DDR	Port 1
H'C1	P2DDR	8	P2 ₇ DDR	P2 ₆ DDR	P2 ₅ DDR	P2 ₄ DDR	P2 ₃ DDR	P2 ₂ DDR	P2 ₁ DDR	P2 ₀ DDR	Port 2
H'C2	P1DR	8	P1 ₇	P1 ₆	P1 ₅	P1 ₄	P1 ₃	P1 ₂	P1 ₁	P1 ₀	Port 1
H'C3	P2DR	8	P2 ₇	P2 ₆	P2 ₅	P2 ₄	P2 ₃	P2 ₂	P2 ₁	P2 ₀	Port 2
H'C4	P3DDR	8	P3 ₇ DDR	P3 ₆ DDR	P3 ₅ DDR	P3 ₄ DDR	P3 ₃ DDR	P3 ₂ DDR	P3 ₁ DDR	P3 ₀ DDR	Port 3
H'C5	P4DDR	8	P4 ₇ DDR	P4 ₆ DDR	P4 ₅ DDR	P4 ₄ DDR	P4 ₃ DDR	P4 ₂ DDR	P4 ₁ DDR	P4 ₀ DDR	Port 4
H'C6	P3DR	8	P3 ₇	P3 ₆	P3 ₅	P3 ₄	P3 ₃	P3 ₂	P3 ₁	P3 ₀	Port 3
H'C7	P4DR	8	P4 ₇	P4 ₆	P4 ₅	P4 ₄	P4 ₃	P4 ₂	P4 ₁	P4 ₀	Port 4
H'C8	P5DDR	8	—	—	—	—	P5 ₃ DDR	P5 ₂ DDR	P5 ₁ DDR	P5 ₀ DDR	Port 5
H'C9	P6DDR	8	—	P6 ₆ DDR	P6 ₅ DDR	P6 ₄ DDR	P6 ₃ DDR	P6 ₂ DDR	P6 ₁ DDR	P6 ₀ DDR	Port 6
H'CA	P5DR	8	—	—	—	—	P5 ₃	P5 ₂	P5 ₁	P5 ₀	Port 5
H'CB	P6DR	8	—	P6 ₆	P6 ₅	P6 ₄	P6 ₃	P6 ₂	P6 ₁	P6 ₀	Port 6
H'CC	—		—	—	—	—	—	—	—	—	
H'CD	P8DDR	8	—	—	—	P8 ₄ DDR	P8 ₃ DDR	P8 ₂ DDR	P8 ₁ DDR	P8 ₀ DDR	Port 8
H'CE	P7DR	8	P7 ₇	P7 ₆	P7 ₅	P7 ₄	P7 ₃	P7 ₂	P7 ₁	P7 ₀	Port 7
H'CF	P8DR	8	—	—	—	P8 ₄	P8 ₃	P8 ₂	P8 ₁	P8 ₀	Port 8

Address (low)	Register Name	Data Bus Width	Bit Names								Module Name
			Bit 7	Bit 6	Bit 5	Bit 4	Bit 3	Bit 2	Bit 1	Bit 0	
H'D0	P9DDR	8	—	—	P9 ₅ DDR	P9 ₄ DDR	P9 ₃ DDR	P9 ₂ DDR	P9 ₁ DDR	P9 ₀ DDR	Port 9
H'D1	PADDR	8	PA ₇ DDR	PA ₆ DDR	PA ₅ DDR	PA ₄ DDR	PA ₃ DDR	PA ₂ DDR	PA ₁ DDR	PA ₀ DDR	Port A
H'D2	P9DR	8	—	—	P9 ₅	P9 ₄	P9 ₃	P9 ₂	P9 ₁	P9 ₀	Port 9
H'D3	PADR	8	PA ₇	PA ₆	PA ₅	PA ₄	PA ₃	PA ₂	PA ₁	PA ₀	Port A
H'D4	PBDDR	8	PB ₇ DDR	PB ₆ DDR	PB ₅ DDR	PB ₄ DDR	PB ₃ DDR	PB ₂ DDR	PB ₁ DDR	PB ₀ DDR	Port B
H'D5	—	—	—	—	—	—	—	—	—	—	—
H'D6	PBDR	8	PB ₇	PB ₆	PB ₅	PB ₄	PB ₃	PB ₂	PB ₁	PB ₀	Port B
H'D7	—	—	—	—	—	—	—	—	—	—	—
H'D8	P2PCR	8	P2 ₇ PCR	P2 ₆ PCR	P2 ₅ PCR	P2 ₄ PCR	P2 ₃ PCR	P2 ₂ PCR	P2 ₁ PCR	P2 ₀ PCR	Port 2
H'D9	—	—	—	—	—	—	—	—	—	—	—
H'DA	P4PCR	8	P4 ₇ PCR	P4 ₆ PCR	P4 ₅ PCR	P4 ₄ PCR	P4 ₃ PCR	P4 ₂ PCR	P4 ₁ PCR	P4 ₀ PCR	Port 4
H'DB	P5PCR	8	—	—	—	—	P5 ₃ PCR	P5 ₂ PCR	P5 ₁ PCR	P5 ₀ PCR	Port 5
H'DC	DADR0	8									D/A converter
H'DD	DADR1	8									
H'DE	DACR	8	DAOE1	DAOE0	DAE	—	—	—	—	—	—
H'DF	—	—	—	—	—	—	—	—	—	—	—
H'E0	ADDRAH	8	AD9	AD8	AD7	AD6	AD5	AD4	AD3	AD2	A/D converter
H'E1	ADDRAL	8	AD1	AD0	—	—	—	—	—	—	—
H'E2	ADDRBH	8	AD9	AD8	AD7	AD6	AD5	AD4	AD3	AD2	—
H'E3	ADDRBL	8	AD1	AD0	—	—	—	—	—	—	—
H'E4	ADDRCH	8	AD9	AD8	AD7	AD6	AD5	AD4	AD3	AD2	—
H'E5	ADDRCL	8	AD1	AD0	—	—	—	—	—	—	—
H'E6	ADDRDH	8	AD9	AD8	AD7	AD6	AD5	AD4	AD3	AD2	—
H'E7	ADDRDL	8	AD1	AD0	—	—	—	—	—	—	—
H'E8	ADCSR	8	ADF	ADIE	ADST	SCAN	CKS	CH2	CH1	CH0	—
H'E9	ADCR	8	TRGE	—	—	—	—	—	—	—	—
H'EA	—	—	—	—	—	—	—	—	—	—	—
H'EB	—	—	—	—	—	—	—	—	—	—	—
H'EC	ABWCR	8	ABW7	ABW6	ABW5	ABW4	ABW3	ABW2	ABW1	ABW0	Bus controller
H'ED	ASTCR	8	AST7	AST6	AST5	AST4	AST3	AST2	AST1	AST0	—
H'EE	WCR	8	—	—	—	—	WMS1	WMS0	WC1	WC0	—
H'EF	WCER	8	WCE7	WCE6	WCE5	WCE4	WCE3	WCE2	WCE1	WCE0	—

Address (low)	Register Name	Data Bus Width	Bit Names								Module Name	
			Bit 7	Bit 6	Bit 5	Bit 4	Bit 3	Bit 2	Bit 1	Bit 0		
H'F0	—	—	—	—	—	—	—	—	—	—	—	
H'F1	MDCR	8	—	—	—	—	—	—	MDS2	MDS1	MDS0	System control
H'F2	SYSCR	8	SSBY	STS2	STS1	STS0	UE	NMIEG	—	RAME		
H'F3	BRCR	8	A23E	A22E	A21E	—	—	—	—	—	BRLE	Bus controller
H'F4	ISCR	8	—	—	IRQ5SC	IRQ4SC	IRQ3SC	IRQ2SC	IRQ1SC	IRQ0SC	—	Interrupt controller
H'F5	IER	8	—	—	IRQ5E	IRQ4E	IRQ3E	IRQ2E	IRQ1E	IRQ0E	—	
H'F6	ISR	8	—	—	IRQ5F	IRQ4F	IRQ3F	IRQ2F	IRQ1F	IRQ0F	—	
H'F7	—	—	—	—	—	—	—	—	—	—	—	
H'F8	IPRA	8	IPRA7	IPRA6	IPRA5	IPRA4	IPRA3	IPRA2	IPRA1	IPRA0	—	
H'F9	IPRB	8	IPRB7	IPRB6	IPRB5	—	IPRB3	IPRB2	IPRB1	—	—	
H'FA	—	—	—	—	—	—	—	—	—	—	—	
H'FB	—	—	—	—	—	—	—	—	—	—	—	
H'FC	—	—	—	—	—	—	—	—	—	—	—	
H'FD	—	—	—	—	—	—	—	—	—	—	—	
H'FE	—	—	—	—	—	—	—	—	—	—	—	
H'FF	—	—	—	—	—	—	—	—	—	—	—	

Legend:

DMAC: DMA controller

ITU: 16-bit integrated timer unit

TPC: Programmable timing pattern controller

SCI: Serial communication interface

WDT: Watchdog timer

- Notes:
1. The address depends on the output trigger setting.
 2. For write access to TCSR, TCNT, and RSTCSR, see section 12.2.4, Notes on Register Rewriting.

B.3 Function

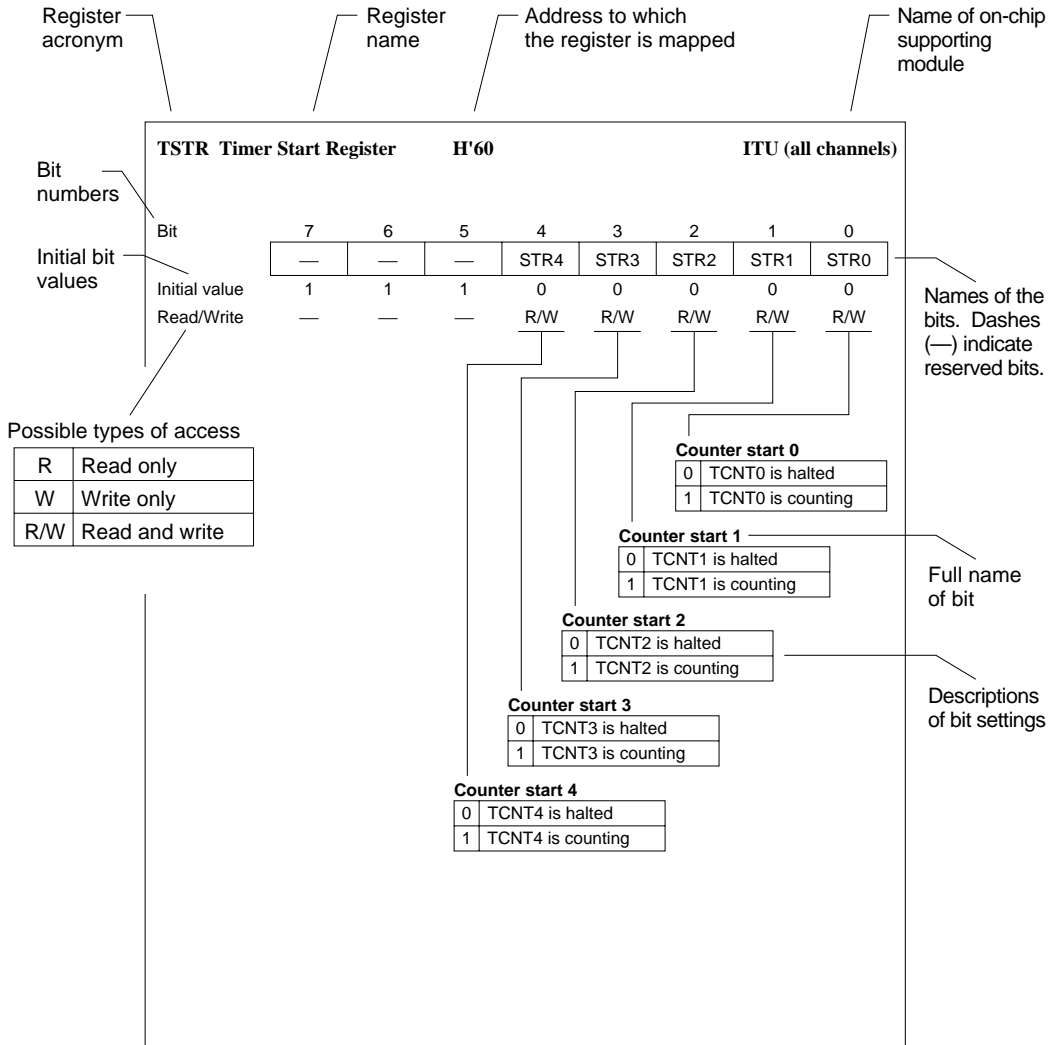

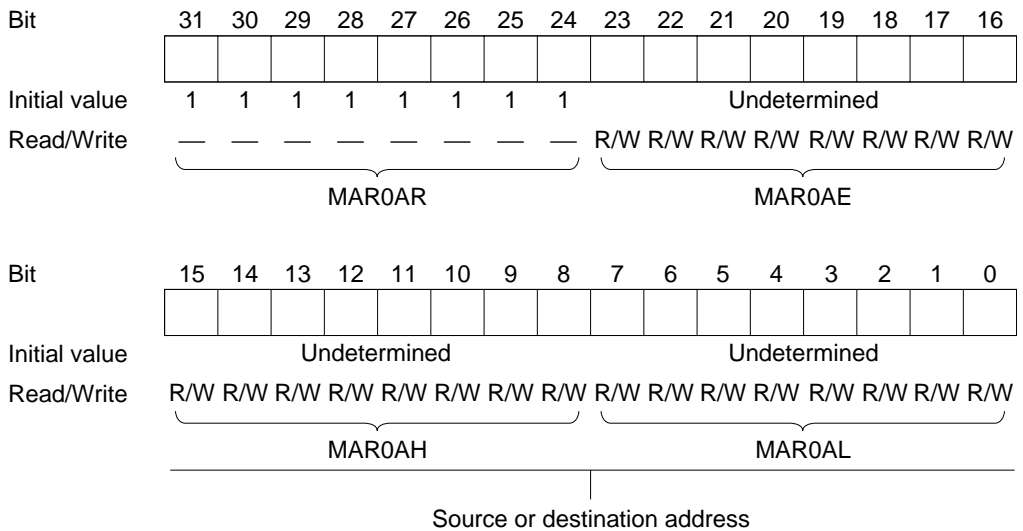
MAR0A R/E/H/L—Memory Address Register 0A R/E/H/L **H'20, H'21,** **DMAC0**
H'22, H'23

ETCR0A H/L—Execute Transfer Count Register 0A H/L**H'24, H'25****DMAC0**

- Short address mode

— I/O mode and idle mode

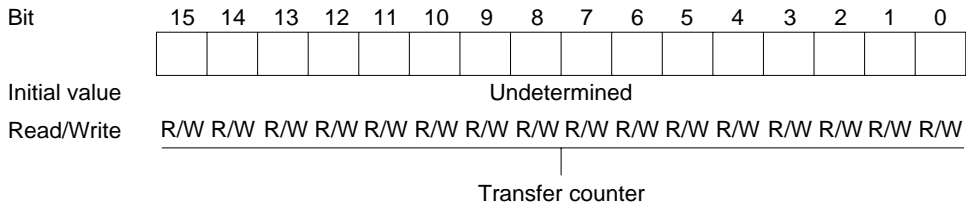

— Repeat mode

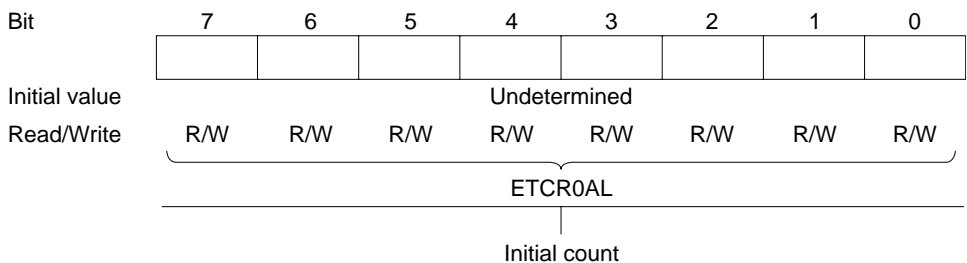
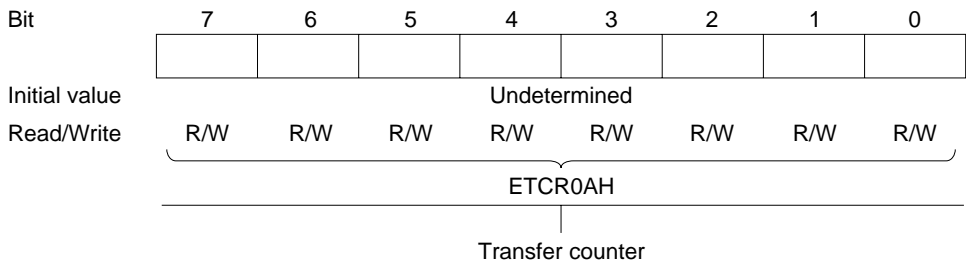

ETCR0A H/L—Execute Transfer Count Register 0A H/L

H'24, H'25

DMAC0

(cont)

- Full address mode

— Normal mode

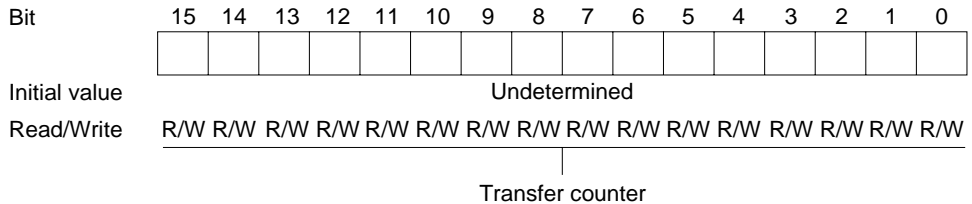

— Block transfer mode

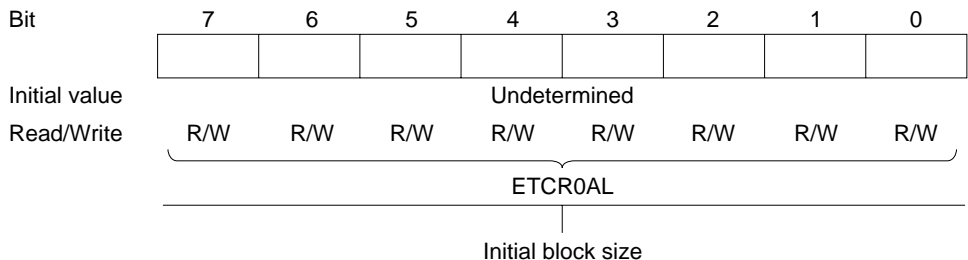
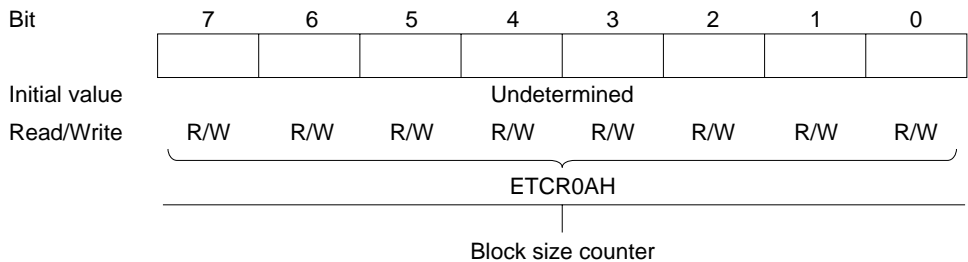

IOAR0A—I/O Address Register 0A**H'26****DMAC0**

Bit	7	6	5	4	3	2	1	0
Initial value				Undetermined				
Read/Write	R/W	R/W	R/W	R/W	R/W	R/W	R/W	R/W

Short address mode: source or destination address

Full address mode: not used

DTCR0A—Data Transfer Control Register 0A

H'27

DMAC0

- Short address mode

Bit	7	6	5	4	3	2	1	0
	DTE	DTSZ	DTID	RPE	DTIE	DTS2	DTS1	DTS0
Initial value	0	0	0	0	0	0	0	0
Read/Write	R/W	R/W	R/W	R/W	R/W	R/W	R/W	R/W

Data transfer select

Bit 2	Bit 1	Bit 0	Data Transfer Activation Source
DTS2	DTS1	DTS0	
0	0	0	Compare match/input capture A interrupt from ITU channel 0
		1	Compare match/input capture A interrupt from ITU channel 1
	1	0	Compare match/input capture A interrupt from ITU channel 2
		1	Compare match/input capture A interrupt from ITU channel 3
1	0	0	SCI0 transmit-data-empty interrupt
		1	SCI0 receive-data-full interrupt
	1	0	Transfer in full address mode (channel A)
		1	Transfer in full address mode (channel A)

Data transfer interrupt enable

0	Interrupt requested by DTE bit is disabled
1	Interrupt requested by DTE bit is enabled

Repeat enable

RPE	DTIE	Description
0	0	I/O mode
	1	
1	0	Repeat mode
	1	Idle mode

Data transfer increment/decrement

0	Incremented: If DTSZ = 0, MAR is incremented by 1 after each transfer If DTSZ = 1, MAR is incremented by 2 after each transfer
1	Decrement: If DTSZ = 0, MAR is decremented by 1 after each transfer If DTSZ = 1, MAR is decremented by 2 after each transfer

Data transfer size

0	Byte-size transfer
1	Word-size transfer

Data transfer enable

0	Data transfer is disabled
1	Data transfer is enabled

DTCR0A—Data Transfer Control Register 0A (cont)

H'27

DMAC0

- Full address mode

Bit	7	6	5	4	3	2	1	0
	DTE	DTSZ	SAID	SAIDE	DTIE	DTS2A	DTS1A	DTS0A
Initial value	0	0	0	0	0	0	0	0
Read/Write	R/W	R/W	R/W	R/W	R/W	R/W	R/W	R/W

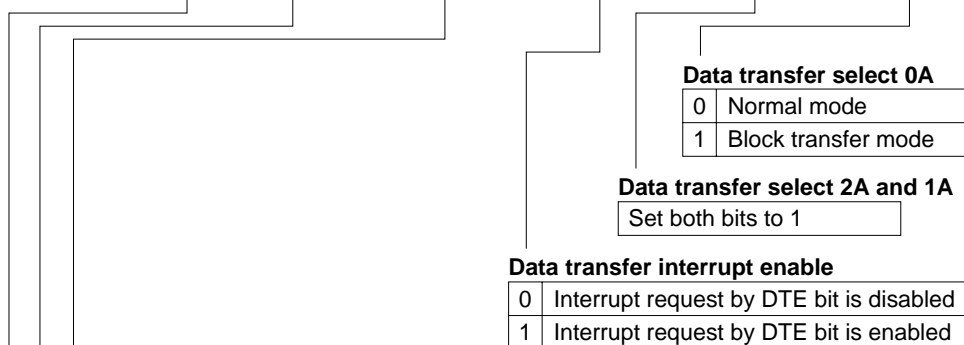
**Source address increment/decrement (bit 5)****Source address increment/decrement enable (bit 4)**

Bit 5	Bit 4	
SAID	SAIDE	Increment/Decrement Enable
0	0	MARA is held fixed
	1	Incremented: If DTSZ = 0, MARA is incremented by 1 after each transfer If DTSZ = 1, MARA is incremented by 2 after each transfer
1	0	MARA is held fixed
	1	Decrement: If DTSZ = 0, MARA is decremented by 1 after each transfer If DTSZ = 1, MARA is decremented by 2 after each transfer

Data transfer size

0	Byte-size transfer
1	Word-size transfer

Data transfer enable

0	Data transfer is disabled
1	Data transfer is enabled

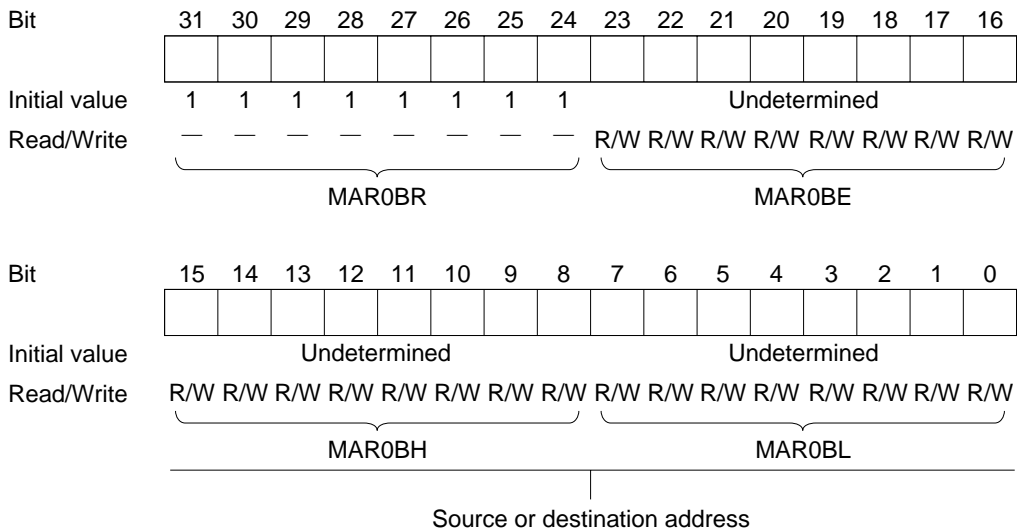
MAR0B R/E/H/L—Memory Address Register 0B R/E/H/L **H'28, H'29, DMAC0**
H'2A, H'2B

ETCR0B H/L—Execute Transfer Count Register 0B H/L**H'2C, H'2D****DMAC0**

- Short address mode

— I/O mode and idle mode

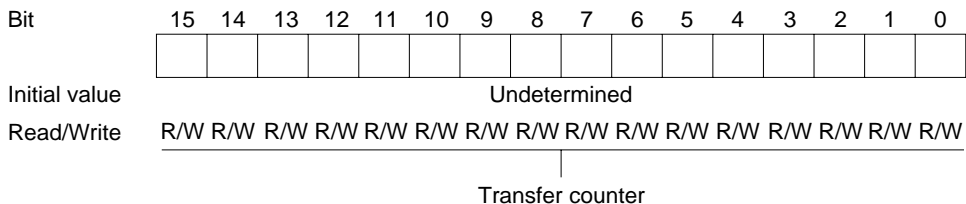

— Repeat mode

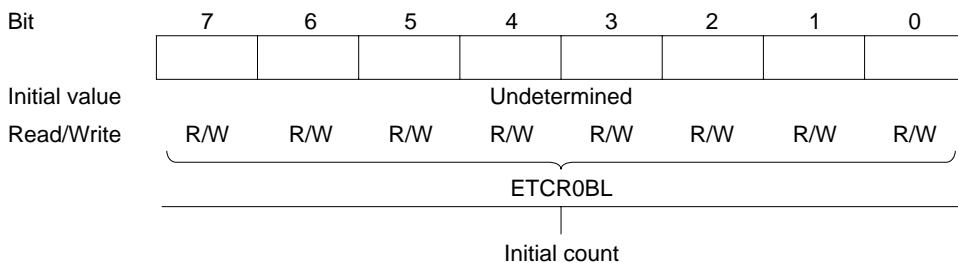
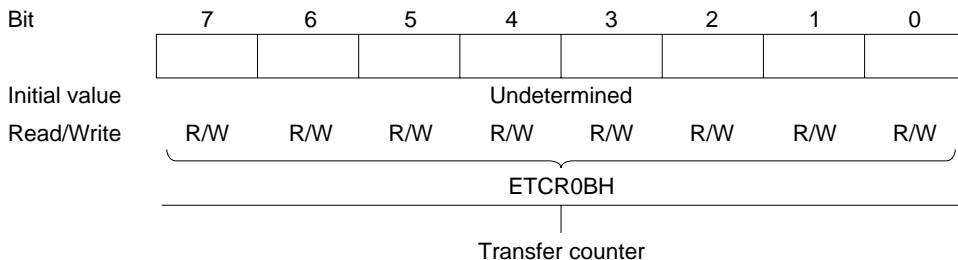

ETCR0B H/L—Execute Transfer Count Register 0B H/L H'2C, H'2D DMAC0

(cont)

- Full address mode

— Normal mode

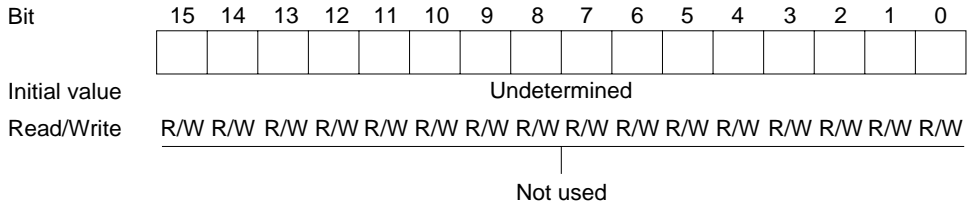

— Block transfer mode

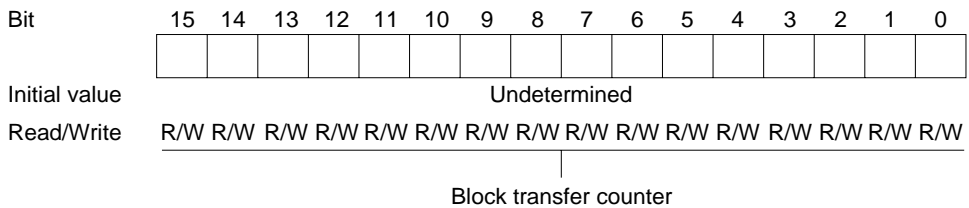

IOAR0B—I/O Address Register 0B H'2E DMAC0

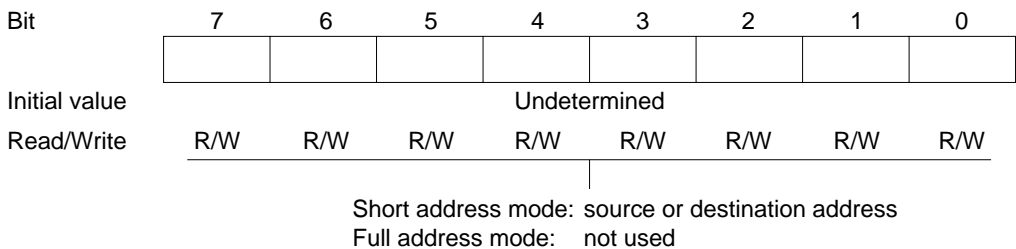

DTCR0B—Data Transfer Control Register 0B**H'2F****DMAC0**

- Short address mode

Bit	7	6	5	4	3	2	1	0
	DTE	DTSZ	DTID	RPE	DTIE	DTS2	DTS1	DTS0
Initial value	0	0	0	0	0	0	0	0
Read/Write	R/W	R/W	R/W	R/W	R/W	R/W	R/W	R/W

Data transfer select

Bit 2	Bit 1	Bit 0	Data Transfer Activation Source
0	0	0	Compare match/input capture A interrupt from ITU channel 0
		1	Compare match/input capture A interrupt from ITU channel 1
	1	0	Compare match/input capture A interrupt from ITU channel 2
		1	Compare match/input capture A interrupt from ITU channel 3
1	0	0	SCI0 transmit-data-empty interrupt
		1	SCI0 receive-data-full interrupt
	1	0	Falling edge of \overline{DREQ} input
		1	Low level of \overline{DREQ} input

Data transfer interrupt enable

0	Interrupt requested by DTE bit is disabled
1	Interrupt requested by DTE bit is enabled An interrupt request is issued to the CPU when the DTE bit = 0

Repeat enable

RPE	DTIE	Description
0	0	I/O mode
	1	
1	0	Repeat mode
	1	Idle mode

Data transfer increment/decrement

0	Incremented: If DTSZ = 0, MAR is incremented by 1 after each transfer If DTSZ = 1, MAR is incremented by 2 after each transfer
1	Decrement: If DTSZ = 0, MAR is decremented by 1 after each transfer If DTSZ = 1, MAR is decremented by 2 after each transfer

Data transfer size

0	Byte-size transfer
1	Word-size transfer

Data transfer enable

0	Data transfer is disabled
1	Data transfer is enabled

DTCR0B—Data Transfer Control Register 0B (cont)**H'2F****DMAC0**

- Full address mode

Bit	7	6	5	4	3	2	1	0
	DTME	—	DAID	DAIDE	TMS	DTS2B	DTS1B	DTS0B
Initial value	0	0	0	0	0	0	0	0
Read/Write	R/W	R/W	R/W	R/W	R/W	R/W	R/W	R/W

Data transfer select 2B to 0B

Bit 2	Bit 1	Bit 0	Data Transfer Activation Source	
DTS2B	DTS1B	DTS0B	Normal Mode	Block Transfer Mode
0	0	0	Auto-request (burst mode)	Compare match/input capture A from ITU channel 0
		1	Not available	Compare match/input capture A from ITU channel 1
	1	0	Auto-request (cycle-steal mode)	Compare match/input capture A from ITU channel 2
		1	Not available	Compare match/input capture A from ITU channel 3
1	0	0	Not available	Not available
		1	Not available	Not available
	1	0	Falling edge of \overline{DREQ}	Falling edge of \overline{DREQ}
		1	Low level input at \overline{DREQ}	Not available

Transfer mode select

0	Destination is the block area in block transfer mode
1	Source is the block area in block transfer mode

Destination address increment/decrement (bit 5)**Destination address increment/decrement enable (bit 4)**

Bit 5	Bit 4	
DAID	DAIDE	Increment/Decrement Enable
0	0	MARB is held fixed
	1	Incremented: If DTSZ = 0, MARB is incremented by 1 after each transfer If DTSZ = 1, MARB is incremented by 2 after each transfer
1	0	MARB is held fixed
	1	Decrement: If DTSZ = 0, MARB is decremented by 1 after each transfer If DTSZ = 1, MARB is decremented by 2 after each transfer

Data transfer master enable

0	Data transfer is disabled
1	Data transfer is enabled

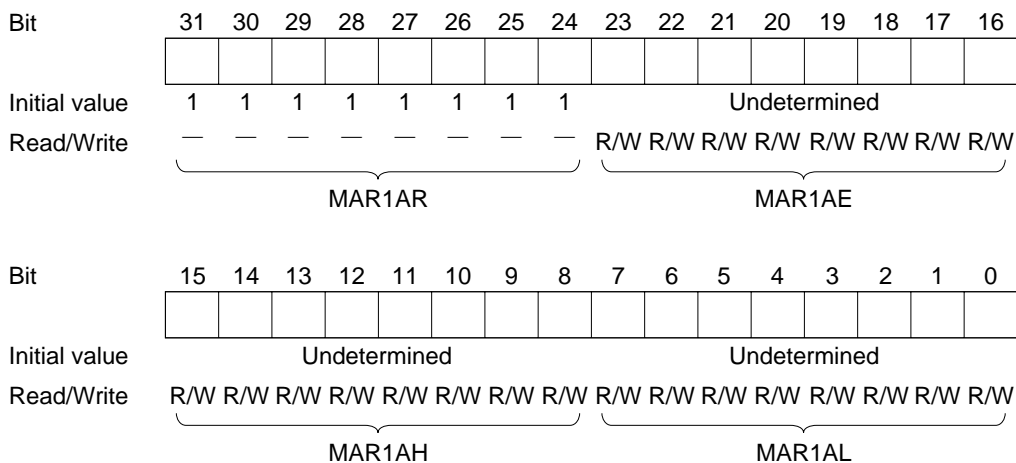
MAR1A R/E/H/L—Memory Address Register 1A R/E/H/L **H'30, H'31, DMAC1**
H'32, H'33

Note: Bit functions are the same as for DMAC0.

ETCR1A H/L—Execute Transfer Count Register 1A H/L **H'34, H'35** **DMAC1**

Bit	15	14	13	12	11	10	9	8	7	6	5	4	3	2	1	0

Initial value Undetermined

Read/Write R/W R/W R/W R/W R/W R/W R/W R/W R/W R/W R/W R/W R/W R/W R/W R/W

Bit	7	6	5	4	3	2	1	0

Initial value Undetermined

Read/Write R/W R/W R/W R/W R/W R/W R/W R/W

ETCR1AH

Bit	7	6	5	4	3	2	1	0

Initial value Undetermined

Read/Write R/W R/W R/W R/W R/W R/W R/W R/W

ETCR1AL

Note: Bit functions are the same as for DMAC0.

IOAR1A—I/O Address Register 1A **H'36** **DMAC1**

Bit	7	6	5	4	3	2	1	0

Initial value Undetermined

Read/Write R/W R/W R/W R/W R/W R/W R/W R/W

Note: Bit functions are the same as for DMAC0.

DTCR1A—Data Transfer Control Register 1A**H'37****DMAC1**

- Short address mode

Bit	7	6	5	4	3	2	1	0
	DTE	DTSZ	DTID	RPE	DTIE	DTS2	DTS1	DTS0
Initial value	0	0	0	0	0	0	0	0
Read/Write	R/W	R/W	R/W	R/W	R/W	R/W	R/W	R/W

- Full address mode

Bit	7	6	5	4	3	2	1	0
	DTE	DTSZ	SAID	SAIDE	DTIE	DTS2A	DTS1A	DTS0A
Initial value	0	0	0	0	0	0	0	0
Read/Write	R/W	R/W	R/W	R/W	R/W	R/W	R/W	R/W

Note: Bit functions are the same as for DMAC0.

MAR1B R/E/H/L—Memory Address Register 1B R/E/H/L**H'38, H'39,
H'3A, H'3B****DMAC1**

Bit	31	30	29	28	27	26	25	24	23	22	21	20	19	18	17	16
Initial value	1	1	1	1	1	1	1		Undetermined							
Read/Write	—	—	—	—	—	—	—	—	R/W R/W R/W R/W R/W R/W R/W R/W							
	MAR1BR							MAR1BE								

Bit	15	14	13	12	11	10	9	8	7	6	5	4	3	2	1	0
Initial value	Undetermined								Undetermined							
Read/Write	R/W R/W R/W R/W R/W R/W R/W R/W								R/W R/W R/W R/W R/W R/W R/W R/W							
	MAR1BH								MAR1BL							

Note: Bit functions are the same as for DMAC0.

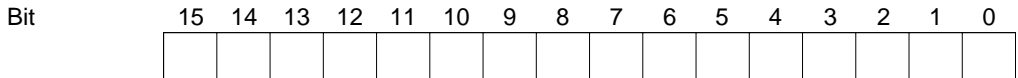
ETCR1B H/L—Execute Transfer Count Register 1B H/L **H'3C, H'3D** **DMAC1**

Initial value Undetermined

Read/Write R/W R/W R/W R/W R/W R/W R/W R/W R/W R/W R/W R/W R/W R/W R/W R/W

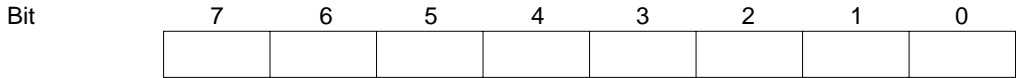

Initial value Undetermined

Read/Write R/W R/W R/W R/W R/W R/W R/W R/W

ETCR1BH

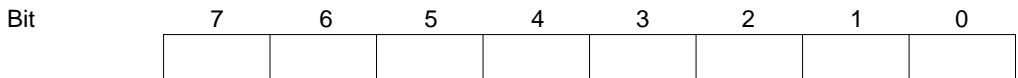

Initial value Undetermined

Read/Write R/W R/W R/W R/W R/W R/W R/W R/W

ETCR1BL

Note: Bit functions are the same as for DMAC0.

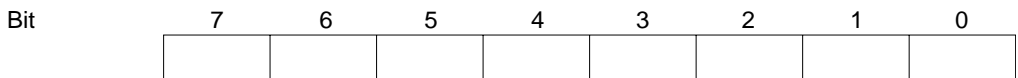
IOAR1B—I/O Address Register 1B **H'3E** **DMAC1**

Initial value Undetermined

Read/Write R/W R/W R/W R/W R/W R/W R/W R/W

Note: Bit functions are the same as for DMAC0.

DTCR1B—Data Transfer Control Register 1B**H'3F****DMAC1**

- Short address mode

Bit	7	6	5	4	3	2	1	0
	DTE	DTSZ	DTID	RPE	DTIE	DTS2	DTS1	DTS0
Initial value	0	0	0	0	0	0	0	0
Read/Write	R/W	R/W	R/W	R/W	R/W	R/W	R/W	R/W

- Full address mode

Bit	7	6	5	4	3	2	1	0
	DTME	—	DAID	DAIDE	TMS	DTS2B	DTS1B	DTS0B
Initial value	0	0	0	0	0	0	0	0
Read/Write	R/W	R/W	R/W	R/W	R/W	R/W	R/W	R/W

Note: Bit functions are the same as for DMAC0.

FLMCR—Flash Memory Control Register

H'40

Flash memory

Bit	7	6	5	4	3	2	1	0
	V _{PP}	V _{PP} E	—	—	EV	PV	E	P
Initial value*	0	0	0	0	0	0	0	0
Read/Write	R	R/W	—	—	R/W*	R/W*	R/W*	R/W*

V_{PP} enable

0	V _{PP} pin 12 V power supply is disabled	(Initial value)
1	V _{PP} pin 12 V power supply is enabled	

Programming power

0	Cleared when 12 V is not applied to V _{PP}	(Initial value)
1	Set when 12 V is applied to V _{PP}	

Erase-verify mode

0	Exit from erase-verify mode	(Initial value)
1	Transition to erase-verify mode	

Program-verify mode

0	Exit from program-verify mode	(Initial value)
1	Transition to program-verify mode	

Erase mode

0	Exit from erase mode	(Initial value)
1	Transition to erase mode	

Program mode

0	Exit from program mode	(Initial value)
1	Transition to program mode	

Note: * The initial value is H'00 in modes 5, 6, and 7 (on-chip flash memory enabled). In modes 1, 2, 3, and 4 (on-chip flash memory disabled), this register cannot be modified and is always read as H'FF.

H8/3048F	Include this register
H8/3048B mask ROM version	Not include this register
H8/3048F-ONE	
H8/3048ZTAT	
H8/3048 mask ROM version	
H8/3047 mask ROM version	
H8/3045 mask ROM version	
H8/3044 mask ROM version	

FLMCR1—Flash Memory Control Register 1

H'40

Flash memory

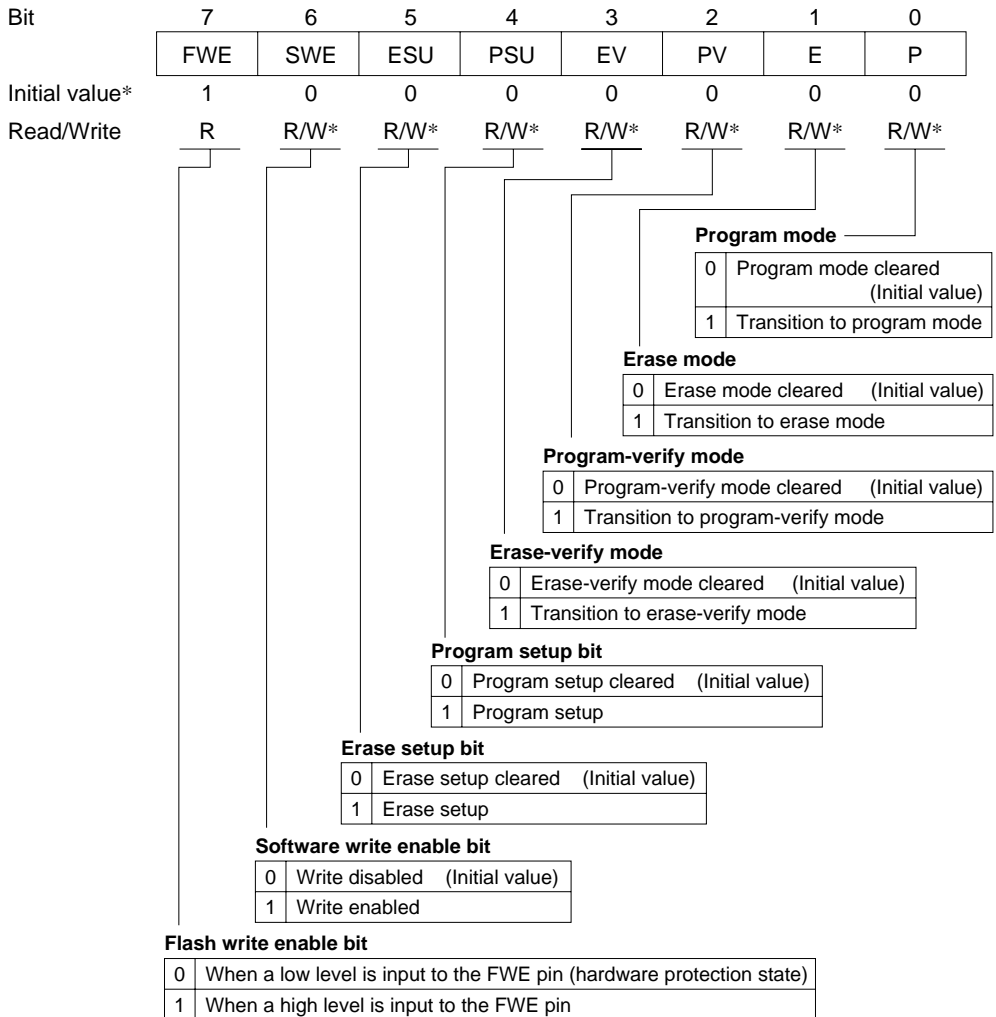

Note: * The initial value is H'00 in modes 5, 6, and 7 (on-chip flash memory enabled). In modes 1, 2, 3, and 4 (on-chip flash memory disabled), this register cannot be modified and is always read as H'FF.

H8/3048F-ONE	Include this register
H8/3048B mask ROM version H8/3048F H8/3048ZTAT H8/3048 mask ROM version H8/3047 mask ROM version H8/3045 mask ROM version H8/3044 mask ROM version	Not include this register

FLMCR2—Flash Memory Control Register 2

H'41

Flash memory

Bit	7	6	5	4	3	2	1	0
	FLER	—	—	—	—	—	—	—
Initial value	0	0	0	0	0	0	0	0
Read/Write	R	R/W	R/W	R/W	R/W	R/W	R/W	R/W

Reserved bits

Flash memory error

0	Flash memory is operating normally. Flash memory program/erase protection (error protection) is disabled. (Initial value)
1	This indicates that an error has occurred during flash memory programming/erasing. Flash memory program/erase protection (error protection) is enabled.

Note: Bits 6 to 0 are reserved bits but are readable/writable.

H8/3048F-ONE	Include this register
H8/3048B mask ROM version H8/3048F H8/3048ZTAT H8/3048 mask ROM version H8/3047 mask ROM version H8/3045 mask ROM version H8/3044 mask ROM version	Not include this register

EBR1—Erase Block Register 1**H'42****Flash memory**

Bit	7	6	5	4	3	2	1	0
	LB7	LB6	LB5	LB4	LB3	LB2	LB1	LB0
Initial value*	0	0	0	0	0	0	0	0
Read/Write	R/W*	R/W*	R/W*	R/W*	R/W*	R/W*	R/W*	R/W*

Large block 7 to 0

0	Block LB7 to LB0 is not selected (Initial value)
1	Block LB7 to LB0 is selected

Note: * The initial value is H'00 in modes 5, 6, and 7 (on-chip flash memory enabled). In modes 1, 2, 3, and 4 (on-chip flash memory disabled), this register cannot be modified and is always read as H'FF.

H8/3048F	Include this register
H8/3048B mask ROM version	Not include this register
H8/3048F-ONE	
H8/3048ZTAT	
H8/3048 mask ROM version	
H8/3047 mask ROM version	
H8/3045 mask ROM version	
H8/3044 mask ROM version	

EBR—Erase Block Register**H'42****Flash memory**

Bit	7	6	5	4	3	2	1	0
	EB7	EB6	EB5	EB4	EB3	EB2	EB1	EB0
Initial value*	0	0	0	0	0	0	0	0
Read/Write	R/W*	R/W*	R/W*	R/W*	R/W*	R/W*	R/W*	R/W*

Erase block specification bits (1)

0	Erase protection state
1	Erasable state

Note: * The initial value is H'00 in modes 5, 6, and 7 (on-chip ROM enabled). In modes 1, 2, 3, and 4 (on-chip ROM disabled), this register cannot be modified and is always read as H'00.

H8/3048F-ONE	Include this register
H8/3048B mask ROM version H8/3048F H8/3048ZTAT H8/3048 mask ROM version H8/3047 mask ROM version H8/3045 mask ROM version H8/3044 mask ROM version	Not include this register

EBR2—Erase Block Register 2**H'43****Flash memory**

Bit	7	6	5	4	3	2	1	0
	SB7	SB6	SB5	SB4	SB3	SB2	SB1	SB0
Initial value*	0	0	0	0	0	0	0	0
Read/Write	R/W*	R/W*	R/W*	R/W*	R/W*	R/W*	R/W*	R/W*

Small block 7 to 0

0	Block SB7 to SB0 is not selected (Initial value)
1	Block SB7 to SB0 is selected

Note: * The initial value is H'00 in modes 5, 6, and 7 (on-chip flash memory enabled). In modes 1, 2, 3, and 4 (on-chip flash memory disabled), this register cannot be modified and is always read as H'FF.

H8/3048F	Include this register
H8/3048B mask ROM version	Not include this register
H8/3048F-ONE	
H8/3048ZTAT	
H8/3048 mask ROM version	
H8/3047 mask ROM version	
H8/3045 mask ROM version	
H8/3044 mask ROM version	

RAMCR—RAM Control Register

H'47

Flash memory

Bit		7	6	5	4	3	2	1	0
		—	—	—	—	RAMS	RAM2	RAM1	—
Modes 1 to 4	Initial value	1	1	1	1	0	0	0	0
	Read/Write	—	—	—	—	R	R	R	—
Modes 5 to 7	Initial value	1	1	1	1	0	0	0	0
	Read/Write	—	—	—	—	R/W	R/W	R/W	R/W
<div style="border-top: 1px solid black; width: 100%; margin-top: 10px;"></div> <div style="border-left: 1px solid black; width: 100%; margin-left: 100px; margin-top: 10px;"></div> <div style="border-right: 1px solid black; width: 100%; margin-right: 100px; margin-top: 10px;"></div> <div style="border-bottom: 1px solid black; width: 100%; margin-bottom: 10px;"></div>									
Reserved bits									

RAM select, RAM2, RAM1

Bit 3	Bit 2	Bit 1	RAM Area	RAM Emulation Status
RAMS	RAM2	RAM1		
0	0/1	0/1	H'FFF000 to H'FFF3FF	No emulation
1	0	0	H'000000 to H'0003FF	Mapping RAM
		1	H'000400 to H'0007FF	
	1	0	H'000800 to H'000BFF	
		1	H'000C00 to H'000FFF	

Note: Bits 7 to 4 are reserved and cannot be modified.
 If data is written to these bits, normal operation is not guaranteed.
 Bit 0 is a reserved bit but is readable/writable.

H8/3048F-ONE	Include this register
H8/3048B mask ROM version H8/3048F H8/3048ZTAT H8/3048 mask ROM version H8/3047 mask ROM version H8/3045 mask ROM version H8/3044 mask ROM version	Not include this register

RAMCR—RAM Control Register

H'48

Flash memory

Bit	7	6	5	4	3	2	1	0
	FLER	—	—	—	RAMS	RAM2	RAM1	RAM0
Initial value	0	1	1	1	0	0	0	0
Read/Write	R/W	—	—	—	R/W	R/W	R/W	R/W

RAM select, RAM 2 to RAM 0

Bit 3	Bit 2	Bit 1	Bit 0	RAM Area
RAMS	RAM 2	RAM 1	RAM 0	
0	1/0	1/0	1/0	H'FFF000 to H'FFF1FF
1	0	0	0	H'01F000 to H'01F1FF
			1	H'01F200 to H'01F3FF
		1	0	H'01F400 to H'01F5FF
			1	H'01F600 to H'01F7FF
	1	0	0	H'01F800 to H'01F9FF
			1	H'01FA00 to H'01FBFF
1	1	0	H'01FC00 to H'01FDFF	
		1	H'01FE00 to H'01FFFF	

Flash memory error

0	Flash memory is not write/erase-protected (is not in error protect mode)	(Initial value)
1	Flash memory is write/erase-protected (is in error protect mode)	

H8/3048F	Include this register
H8/3048B mask ROM version H8/3048F-ONE H8/3048ZTAT H8/3048 mask ROM version H8/3047 mask ROM version H8/3045 mask ROM version H8/3044 mask ROM version	Not include this register

DASTCR—D/A Standby Control Register**H'5C****System control**

Bit	7	6	5	4	3	2	1	0
	—	—	—	—	—	—	—	DASTE
Initial value	1	1	1	1	1	1	1	0
Read/Write	—	—	—	—	—	—	—	R/W

D/A standby enable

0	D/A output is disabled in software standby mode (Initial value)
1	D/A output is enabled in software standby mode

DIVCR—Division Control Register**H'5D****System control**

Bit	7	6	5	4	3	2	1	0
	—	—	—	—	—	—	DIV1	DIV0
Initial value	1	1	1	1	1	1	0	0
Read/Write	—	—	—	—	—	—	R/W	R/W

Divide 1 and 0

Bit 1	Bit 0	Frequency Division Ratio
DIV1	DIV0	
0	0	1/1 (Initial value)
	1	1/2
1	0	1/4
	1	1/8

MSTCR—Module Standby Control Register

H'5E

System control

Bit	7	6	5	4	3	2	1	0
	PSTOP	—	MSTOP5	MSTOP4	MSTOP3	MSTOP2	MSTOP1	MSTOP0
Initial value	0	1	0	0	0	0	0	0
Read/Write	R/W	—	R/W	R/W	R/W	R/W	R/W	R/W

Module standby 0

0	A/D converter operates normally (Initial value)
1	A/D converter is in standby state

Module standby 1

0	Refresh controller operates normally (Initial value)
1	Refresh controller is in standby state

Module standby 2

0	DMAC operates normally (Initial value)
1	DMAC is in standby state

Module standby 3

0	SCI1 operates normally (Initial value)
1	SCI1 is in standby state

Module standby 4

0	SCI0 operates normally (Initial value)
1	SCI0 is in standby state

Module standby 5

0	ITU operates normally (Initial value)
1	ITU is in standby state

φ clock stop

0	φ clock output is enabled (Initial value)
1	φ clock output is disabled

CSCR—Chip Select Control Register**H'5F****System control**

Bit	7	6	5	4	3	2	1	0
	CS7E	CS6E	CS5E	CS4E	—	—	—	—
Initial value	0	0	0	0	1	1	1	1
Read/Write	R/W	R/W	R/W	R/W	—	—	—	—

Chip select 7 to 4 enable

Bit n	Description
0	Output of chip select signal CSn is disabled (Initial value)
1	Output of chip select signal CSn is enabled

(n = 7 to 4)

TSTR—Timer Start Register**H'60****ITU (all channels)**

Bit	7	6	5	4	3	2	1	0
	—	—	—	STR4	STR3	STR2	STR1	STR0
Initial value	1	1	1	0	0	0	0	0
Read/Write	—	—	—	R/W	R/W	R/W	R/W	R/W

Counter start 0

0	TCNT0 is halted
1	TCNT0 is counting

Counter start 1

0	TCNT1 is halted
1	TCNT1 is counting

Counter start 2

0	TCNT2 is halted
1	TCNT2 is counting

Counter start 3

0	TCNT3 is halted
1	TCNT3 is counting

Counter start 4

0	TCNT4 is halted
1	TCNT4 is counting

TSNC—Timer Synchro Register

H'61

ITU (all channels)

Bit	7	6	5	4	3	2	1	0
	—	—	—	SYNC4	SYNC3	SYNC2	SYNC1	SYNC0
Initial value	1	1	1	0	0	0	0	0
Read/Write	—	—	—	R/W	R/W	R/W	R/W	R/W

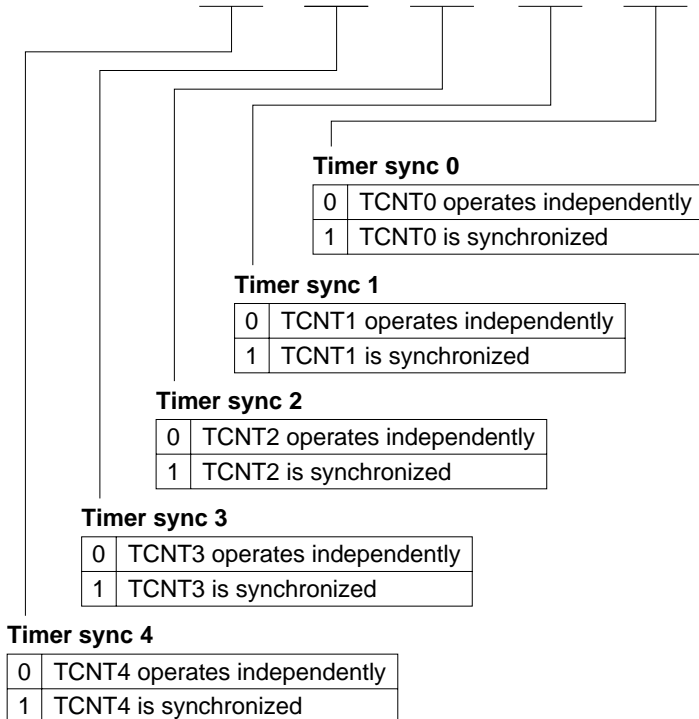

TMDR—Timer Mode Register

H'62

ITU (all channels)

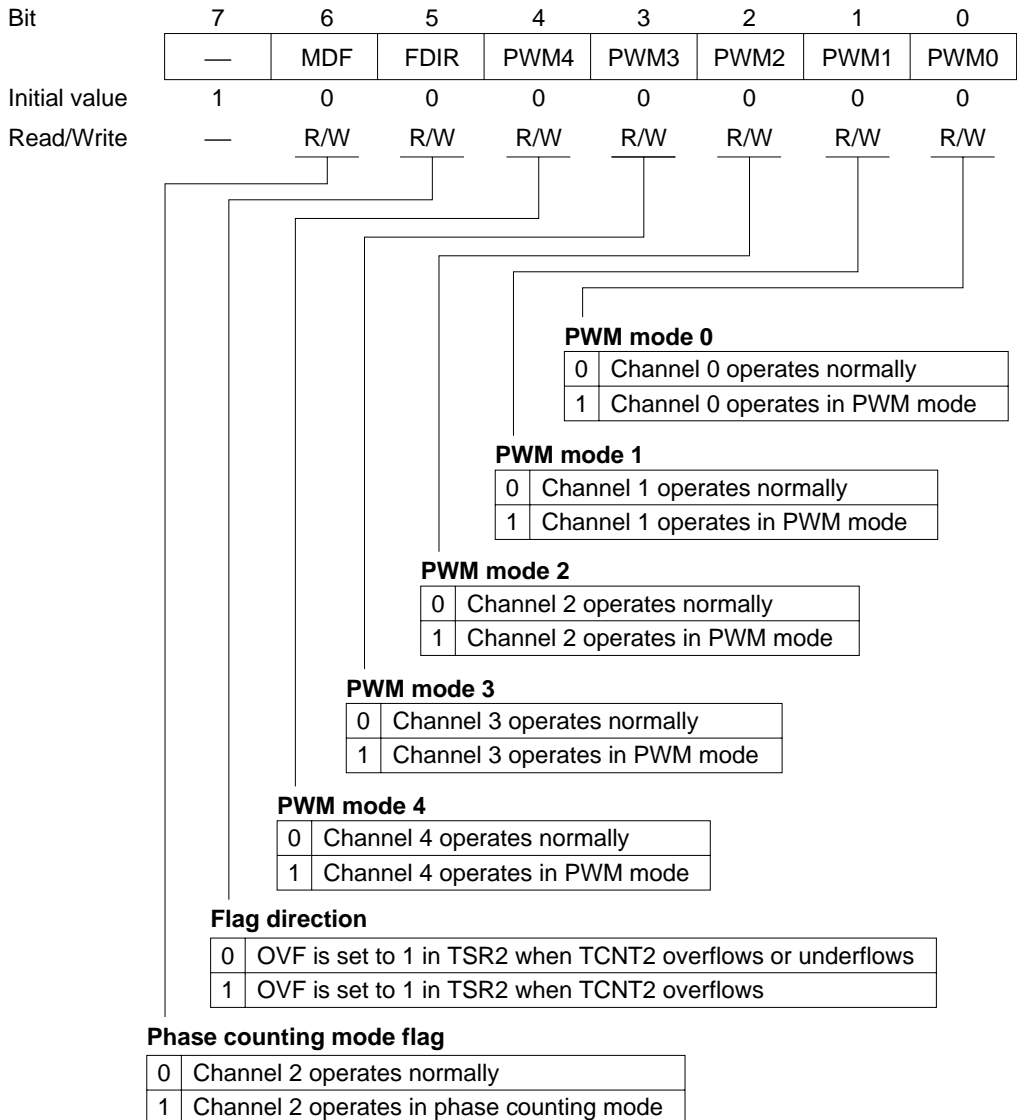

TFCR—Timer Function Control Register

H'63

ITU (all channels)

Bit	7	6	5	4	3	2	1	0
	—	—	CMD1	CMD0	BFB4	BFA4	BFB3	BFA3
Initial value	1	1	0	0	0	0	0	0
Read/Write	—	—	R/W	R/W	R/W	R/W	R/W	R/W

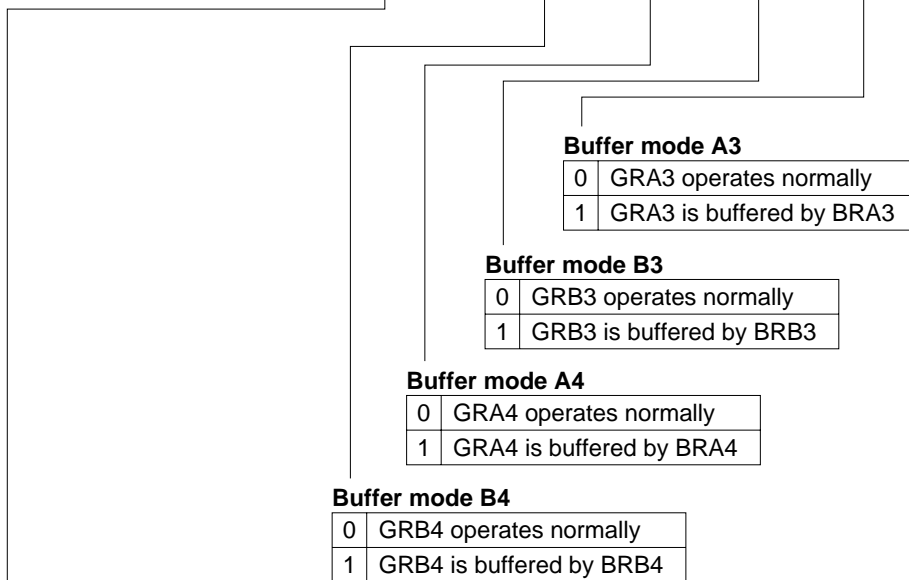
**Combination mode 1 and 0**

Bit 5	Bit 4	
CMD1	CMD0	Operating Mode of Channels 3 and 4
0	0	Channels 3 and 4 operate normally
	1	
1	0	Channels 3 and 4 operate together in complementary PWM mode
	1	Channels 3 and 4 operate together in reset-synchronized PWM mode

TCR0—Timer Control Register 0

H'64

ITU0

Bit	7	6	5	4	3	2	1	0
	—	CCLR1	CCLR0	CKEG1	CKEG0	TPSC2	TPSC1	TPSC0
Initial value	1	0	0	0	0	0	0	0
Read/Write	—	R/W	R/W	R/W	R/W	R/W	R/W	R/W

Timer prescaler 2 to 0

Bit 2	Bit 1	Bit 0	TCNT Clock Source
TPSC2	TPSC1	TPSC0	
0	0	0	Internal clock: ϕ
		1	Internal clock: $\phi/2$
	1	0	Internal clock: $\phi/4$
		1	Internal clock: $\phi/8$
1	0	0	External clock A: TCLKA input
		1	External clock B: TCLKB input
	1	0	External clock C: TCLKC input
		1	External clock D: TCLKD input

Clock edge 1 and 0

Bit 4	Bit 3	Counted Edges of External Clock
CKEG1	CKEG0	
0	0	Rising edges counted
	1	Falling edges counted
1	—	Both edges counted

Counter clear 1 and 0

Bit 6	Bit 5	TCNT Clear Source
CCLR1	CCLR0	
0	0	TCNT is not cleared
	1	TCNT is cleared by GRA compare match or input capture
1	0	TCNT is cleared by GRB compare match or input capture
	1	Synchronous clear: TCNT is cleared in synchronization with other synchronized timers

TIOR0—Timer I/O Control Register 0

H'65

ITU0

Bit	7	6	5	4	3	2	1	0
	—	IOB2	IOB1	IOB0	—	IOA2	IOA1	IOA0
Initial value	1	0	0	0	1	0	0	0
Read/Write	—	R/W	R/W	R/W	—	R/W	R/W	R/W

I/O control A2 to A0

Bit 2	Bit 1	Bit 0	GRA Function	
IOA2	IOA1	IOA0		
0	0	0	GRA is an output compare register	No output at compare match
		1		0 output at GRA compare match
	1	0		1 output at GRA compare match
		1		Output toggles at GRA compare match
1	0	0	GRA is an input capture register	GRA captures rising edge of input
		1		GRA captures falling edge of input
	1	0		GRA captures both edges of input
		1		

I/O control B2 to B0

Bit 6	Bit 5	Bit 4	GRB Function	
IOB2	IOB1	IOB0		
0	0	0	GRB is an output compare register	No output at compare match
		1		0 output at GRB compare match
	1	0		1 output at GRB compare match
		1		Output toggles at GRB compare match
1	0	0	GRB is an input capture register	GRB captures rising edge of input
		1		GRB captures falling edge of input
	1	0		GRB captures both edges of input
		1		

TIER0—Timer Interrupt Enable Register 0**H'66****ITU0**

Bit	7	6	5	4	3	2	1	0
	—	—	—	—	—	OVIE	IMIEB	IMIEA
Initial value	1	1	1	1	1	0	0	0
Read/Write	—	—	—	—	—	R/W	R/W	R/W

Input capture/compare match interrupt enable A

0	IMIA interrupt requested by IMFA flag is disabled
1	IMIA interrupt requested by IMFA flag is enabled

Input capture/compare match interrupt enable B

0	IMIB interrupt requested by IMFB flag is disabled
1	IMIB interrupt requested by IMFB flag is enabled

Overflow interrupt enable

0	OVI interrupt requested by OVF flag is disabled
1	OVI interrupt requested by OVF flag is enabled

TSR0—Timer Status Register 0

H'67

ITU0

Bit	7	6	5	4	3	2	1	0
	—	—	—	—	—	OVF	IMFB	IMFA
Initial value	1	1	1	1	1	0	0	0
Read/Write	—	—	—	—	—	R/(W)*	R/(W)*	R/(W)*

Input capture/compare match flag A

0	[Clearing condition] Read IMFA when IMFA = 1, then write 0 in IMFA
1	[Setting conditions] TCNT = GRA when GRA functions as an output compare register. TCNT value is transferred to GRA by an input capture signal, when GRA functions as an input capture register.

Input capture/compare match flag B

0	[Clearing condition] Read IMFB when IMFB = 1, then write 0 in IMFB
1	[Setting conditions] TCNT = GRB when GRB functions as an output compare register. TCNT value is transferred to GRB by an input capture signal, when GRB functions as an input capture register.

Overflow flag

0	[Clearing condition] Read OVF when OVF = 1, then write 0 in OVF
1	[Setting condition] TCNT overflowed from H'FFFF to H'0000 or underflowed from H'0000 to H'FFFF

Note: * Only 0 can be written, to clear the flag.

TCNT0 H/L—Timer Counter 0 H/L**H'68, H'69****ITU0**

Bit	15	14	13	12	11	10	9	8	7	6	5	4	3	2	1	0
Initial value	0	0	0	0	0	0	0	0	0	0	0	0	0	0	0	0
Read/Write	R/W	R/W	R/W	R/W	R/W	R/W	R/W	R/W	R/W	R/W	R/W	R/W	R/W	R/W	R/W	R/W

|
Up-counter

GRA0 H/L—General Register A0 H/L**H'6A, H'6B****ITU0**

Bit	15	14	13	12	11	10	9	8	7	6	5	4	3	2	1	0
Initial value	1	1	1	1	1	1	1	1	1	1	1	1	1	1	1	1
Read/Write	R/W	R/W	R/W	R/W	R/W	R/W	R/W	R/W	R/W	R/W	R/W	R/W	R/W	R/W	R/W	R/W

|
Output compare or input capture register

GRB0 H/L—General Register B0 H/L**H'6C, H'6D****ITU0**

Bit	15	14	13	12	11	10	9	8	7	6	5	4	3	2	1	0
Initial value	1	1	1	1	1	1	1	1	1	1	1	1	1	1	1	1
Read/Write	R/W	R/W	R/W	R/W	R/W	R/W	R/W	R/W	R/W	R/W	R/W	R/W	R/W	R/W	R/W	R/W

|
Output compare or input capture register

TCR1—Timer Control Register 1**H'6E****ITU1**

Bit	7	6	5	4	3	2	1	0
	—	CCLR1	CCLR0	CKEG1	CKEG0	TPSC2	TPSC1	TPSC0
Initial value	1	0	0	0	0	0	0	0
Read/Write	—	R/W	R/W	R/W	R/W	R/W	R/W	R/W

Note: Bit functions are the same as for ITU0.

TIOR1—Timer I/O Control Register 1**H'6F****ITU1**

Bit	7	6	5	4	3	2	1	0
	—	IOB2	IOB1	IOB0	—	IOA2	IOA1	IOA0
Initial value	1	0	0	0	1	0	0	0
Read/Write	—	R/W	R/W	R/W	—	R/W	R/W	R/W

Note: Bit functions are the same as for ITU0.

TIER1—Timer Interrupt Enable Register 1**H'70****ITU1**

Bit	7	6	5	4	3	2	1	0
	—	—	—	—	—	OVIE	IMIEB	IMIEA
Initial value	1	1	1	1	1	0	0	0
Read/Write	—	—	—	—	—	R/W	R/W	R/W

Note: Bit functions are the same as for ITU0.

TSR1—Timer Status Register 1**H'71****ITU1**

Bit	7	6	5	4	3	2	1	0
	—	—	—	—	—	OVF	IMFB	IMFA
Initial value	1	1	1	1	1	0	0	0
Read/Write	—	—	—	—	—	R/(W)*	R/(W)*	R/(W)*

Notes: Bit functions are the same as for ITU0.

* Only 0 can be written, to clear the flag.

TCNT1 H/L—Timer Counter 1 H/L**H'72, H'73****ITU1**

Bit	15	14	13	12	11	10	9	8	7	6	5	4	3	2	1	0
Initial value	0	0	0	0	0	0	0	0	0	0	0	0	0	0	0	0
Read/Write	R/W	R/W	R/W	R/W	R/W	R/W	R/W	R/W	R/W	R/W	R/W	R/W	R/W	R/W	R/W	R/W

Note: Bit functions are the same as for ITU0.

GRA1 H/L—General Register A1 H/L**H'74, H'75****ITU1**

Bit	15	14	13	12	11	10	9	8	7	6	5	4	3	2	1	0
	<input type="checkbox"/>	<input type="checkbox"/>	<input type="checkbox"/>	<input type="checkbox"/>	<input type="checkbox"/>	<input type="checkbox"/>	<input type="checkbox"/>	<input type="checkbox"/>	<input type="checkbox"/>	<input type="checkbox"/>	<input type="checkbox"/>	<input type="checkbox"/>	<input type="checkbox"/>	<input type="checkbox"/>	<input type="checkbox"/>	<input type="checkbox"/>
Initial value	1	1	1	1	1	1	1	1	1	1	1	1	1	1	1	1
Read/Write	R/W	R/W	R/W	R/W	R/W	R/W	R/W	R/W	R/W	R/W	R/W	R/W	R/W	R/W	R/W	R/W

Note: Bit functions are the same as for ITU0.

GRB1 H/L—General Register B1 H/L**H'76, H'77****ITU1**

Bit	15	14	13	12	11	10	9	8	7	6	5	4	3	2	1	0
	<input type="checkbox"/>	<input type="checkbox"/>	<input type="checkbox"/>	<input type="checkbox"/>	<input type="checkbox"/>	<input type="checkbox"/>	<input type="checkbox"/>	<input type="checkbox"/>	<input type="checkbox"/>	<input type="checkbox"/>	<input type="checkbox"/>	<input type="checkbox"/>	<input type="checkbox"/>	<input type="checkbox"/>	<input type="checkbox"/>	<input type="checkbox"/>
Initial value	1	1	1	1	1	1	1	1	1	1	1	1	1	1	1	1
Read/Write	R/W	R/W	R/W	R/W	R/W	R/W	R/W	R/W	R/W	R/W	R/W	R/W	R/W	R/W	R/W	R/W

Note: Bit functions are the same as for ITU0.

TCR2—Timer Control Register 2**H'78****ITU2**

Bit	7	6	5	4	3	2	1	0
	<input type="checkbox"/>	CCLR1	CCLR0	CKEG1	CKEG0	TPSC2	TPSC1	TPSC0
Initial value	1	0	0	0	0	0	0	0
Read/Write	—	R/W	R/W	R/W	R/W	R/W	R/W	R/W

Notes: 1. Bit functions are the same as for ITU0.

2. When channel 2 is used in phase counting mode, the counter clock source selection by bits TPSC2 to TPSC0 is ignored.

TIOR2—Timer I/O Control Register 2**H'79****ITU2**

Bit	7	6	5	4	3	2	1	0
	—	IOB2	IOB1	IOB0	—	IOA2	IOA1	IOA0
Initial value	1	0	0	0	1	0	0	0
Read/Write	—	R/W	R/W	R/W	—	R/W	R/W	R/W

Note: Bit functions are the same as for ITU0.

TIER2—Timer Interrupt Enable Register 2**H'7A****ITU2**

Bit	7	6	5	4	3	2	1	0
	—	—	—	—	—	OVIE	IMIEB	IMIEA
Initial value	1	1	1	1	1	0	0	0
Read/Write	—	—	—	—	—	R/W	R/W	R/W

Note: Bit functions are the same as for ITU0.

TSR2—Timer Status Register 2**H'7B****ITU2**

Bit	7	6	5	4	3	2	1	0
	—	—	—	—	—	OVF	IMFB	IMFA
Initial value	1	1	1	1	1	0	0	0
Read/Write	—	—	—	—	—	R/(W)*	R/(W)*	R/(W)*

The function is the same as ITU0.

Overflow flag

0	[Clearing condition] Read OVF when OVF = 1, then write 0 in OVF.
1	[Setting condition] The TCNT value overflows (from H'FFFF to H'0000) or underflows (from H'0000 to H'FFFF)

Notes: Bit functions are the same as for ITU0.

* Only 0 can be written, to clear the flag.

TCNT2 H/L—Timer Counter 2 H/L**H'7C, H'7D****ITU2**

Bit	15	14	13	12	11	10	9	8	7	6	5	4	3	2	1	0
Initial value	0	0	0	0	0	0	0	0	0	0	0	0	0	0	0	0
Read/Write	R/W	R/W	R/W	R/W	R/W	R/W	R/W	R/W	R/W	R/W	R/W	R/W	R/W	R/W	R/W	R/W

Phase counting mode: up/down counter
Other modes: up-counter

GRA2 H/L—General Register A2 H/L**H'7E, H'7F****ITU2**

Bit	15	14	13	12	11	10	9	8	7	6	5	4	3	2	1	0
Initial value	1	1	1	1	1	1	1	1	1	1	1	1	1	1	1	1
Read/Write	R/W	R/W	R/W	R/W	R/W	R/W	R/W	R/W	R/W	R/W	R/W	R/W	R/W	R/W	R/W	R/W

Note: Bit functions are the same as for ITU0.

GRB2 H/L—General Register B2 H/L**H'80, H'81****ITU2**

Bit	15	14	13	12	11	10	9	8	7	6	5	4	3	2	1	0
Initial value	1	1	1	1	1	1	1	1	1	1	1	1	1	1	1	1
Read/Write	R/W	R/W	R/W	R/W	R/W	R/W	R/W	R/W	R/W	R/W	R/W	R/W	R/W	R/W	R/W	R/W

Note: Bit functions are the same as for ITU0.

TCR3—Timer Control Register 3**H'82****ITU3**

Bit	7	6	5	4	3	2	1	0
	—	CCLR1	CCLR0	CKEG1	CKEG0	TPSC2	TPSC1	TPSC0
Initial value	1	0	0	0	0	0	0	0
Read/Write	—	R/W	R/W	R/W	R/W	R/W	R/W	R/W

Note: Bit functions are the same as for ITU0.

TIOR3—Timer I/O Control Register 3**H'83****ITU3**

Bit	7	6	5	4	3	2	1	0
	—	IOB2	IOB1	IOB0	—	IOA2	IOA1	IOA0
Initial value	1	0	0	0	1	0	0	0
Read/Write	—	R/W	R/W	R/W	—	R/W	R/W	R/W

Note: Bit functions are the same as for ITU0.

TIER3—Timer Interrupt Enable Register 3**H'84****ITU3**

Bit	7	6	5	4	3	2	1	0
	—	—	—	—	—	OVIE	IMIEB	IMIEA
Initial value	1	1	1	1	1	0	0	0
Read/Write	—	—	—	—	—	R/W	R/W	R/W

Note: Bit functions are the same as for ITU0.

TSR3—Timer Status Register 3

H'85

ITU3

Bit	7	6	5	4	3	2	1	0
	—	—	—	—	—	OVF	IMFB	IMFA
Initial value	1	1	1	1	1	0	0	0
Read/Write	—	—	—	—	—	R/(W)*	R/(W)*	R/(W)*

Overflow flag

0	[Clearing condition] Read OVF when OVF = 1, then write 1 in OVF
1	[Setting condition] TCNT overflowed from H'FFFF to H'0000 or underflowed from H'0000 to H'FFFF

Bit functions are the same as for ITU0

Note: * Only 0 can be written, to clear the flag.

TCNT3 H/L—Timer Counter 3 H/L

H'86, H'87

ITU3

Bit	15	14	13	12	11	10	9	8	7	6	5	4	3	2	1	0
Initial value	0	0	0	0	0	0	0	0	0	0	0	0	0	0	0	0
Read/Write	R/W	R/W	R/W	R/W	R/W	R/W	R/W	R/W	R/W	R/W	R/W	R/W	R/W	R/W	R/W	R/W

Complementary PWM mode: up/down counter
Other modes: up-counter

GRA3 H/L—General Register A3 H/L

H'88, H'89

ITU3

Bit	15	14	13	12	11	10	9	8	7	6	5	4	3	2	1	0
Initial value	1	1	1	1	1	1	1	1	1	1	1	1	1	1	1	1
Read/Write	R/W	R/W	R/W	R/W	R/W	R/W	R/W	R/W	R/W	R/W	R/W	R/W	R/W	R/W	R/W	R/W

Output compare or input capture register (can be buffered)

GRB3 H/L—General Register B3 H/L**H'8A, H'8B****ITU3**

Bit	15	14	13	12	11	10	9	8	7	6	5	4	3	2	1	0
Initial value	1	1	1	1	1	1	1	1	1	1	1	1	1	1	1	1
Read/Write	R/W	R/W	R/W	R/W	R/W	R/W	R/W	R/W	R/W	R/W	R/W	R/W	R/W	R/W	R/W	R/W

Output compare or input capture register (can be buffered)

BRA3 H/L—Buffer Register A3 H/L**H'8C, H'8D****ITU3**

Bit	15	14	13	12	11	10	9	8	7	6	5	4	3	2	1	0
Initial value	1	1	1	1	1	1	1	1	1	1	1	1	1	1	1	1
Read/Write	R/W	R/W	R/W	R/W	R/W	R/W	R/W	R/W	R/W	R/W	R/W	R/W	R/W	R/W	R/W	R/W

Used to buffer GRA

BRB3 H/L—Buffer Register B3 H/L**H'8E, H'8F****ITU3**

Bit	15	14	13	12	11	10	9	8	7	6	5	4	3	2	1	0
Initial value	1	1	1	1	1	1	1	1	1	1	1	1	1	1	1	1
Read/Write	R/W	R/W	R/W	R/W	R/W	R/W	R/W	R/W	R/W	R/W	R/W	R/W	R/W	R/W	R/W	R/W

Used to buffer GRB

TOER—Timer Output Enable Register

H'90

ITU (all channels)

Bit	7	6	5	4	3	2	1	0
	—	—	EXB4	EXA4	EB3	EB4	EA4	EA3
Initial value	1	1	1	1	1	1	1	1
Read/Write	—	—	R/W	R/W	R/W	R/W	R/W	R/W

Master enable TIOCA3

0	TIOCA ₃ output is disabled regardless of TIOR3, TMDR, and TFCR settings
1	TIOCA ₃ is enabled for output according to TIOR3, TMDR, and TFCR settings

Master enable TIOCA4

0	TIOCA ₄ output is disabled regardless of TIOR4, TMDR, and TFCR settings
1	TIOCA ₄ is enabled for output according to TIOR4, TMDR, and TFCR settings

Master enable TIOCB4

0	TIOCB ₄ output is disabled regardless of TIOR4 and TFCR settings
1	TIOCB ₄ is enabled for output according to TIOR4 and TFCR settings

Master enable TIOCB3

0	TIOCB ₃ output is disabled regardless of TIOR3 and TFCR settings
1	TIOCB ₃ is enabled for output according to TIOR3 and TFCR settings

Master enable TOCXA4

0	TOCXA ₄ output is disabled regardless of TFCR settings
1	TOCXA ₄ is enabled for output according to TFCR settings

Master enable TOCXB4

0	TOCXB ₄ output is disabled regardless of TFCR settings
1	TOCXB ₄ is enabled for output according to TFCR settings

TOCR—Timer Output Control Register

H'91

ITU (all channels)

Bit	7	6	5	4	3	2	1	0
	—	—	—	XTGD	—	—	OLS4	OLS3
Initial value	1	1	1	1	1	1	1	1
Read/Write	—	—	—	R/W	—	—	R/W	R/W

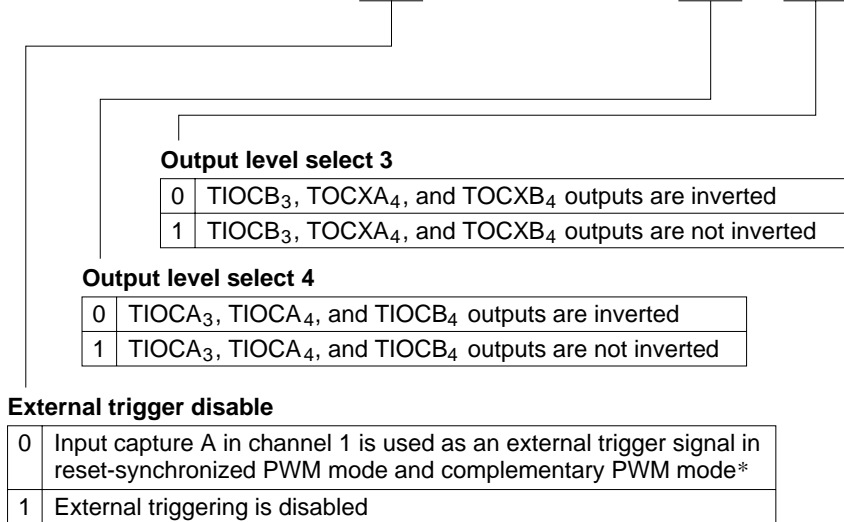

Note: * When an external trigger occurs, bits 5 to 0 in TOER are cleared to 0, disabling ITU output.

TCR4—Timer Control Register 4**H'92****ITU4**

Bit	7	6	5	4	3	2	1	0
	—	CCLR1	CCLR0	CKEG1	CKEG0	TPSC2	TPSC1	TPSC0
Initial value	1	0	0	0	0	0	0	0
Read/Write	—	R/W	R/W	R/W	R/W	R/W	R/W	R/W

Note: Bit functions are the same as for ITU0.

TIOR4—Timer I/O Control Register 4**H'93****ITU4**

Bit	7	6	5	4	3	2	1	0
	—	IOB2	IOB1	IOB0	—	IOA2	IOA1	IOA0
Initial value	1	0	0	0	1	0	0	0
Read/Write	—	R/W	R/W	R/W	—	R/W	R/W	R/W

Note: Bit functions are the same as for ITU0.

TIER4—Timer Interrupt Enable Register 4**H'94****ITU4**

Bit	7	6	5	4	3	2	1	0
	—	—	—	—	—	OVIE	IMIEB	IMIEA
Initial value	1	1	1	1	1	0	0	0
Read/Write	—	—	—	—	—	R/W	R/W	R/W

Note: Bit functions are the same as for ITU0.

TSR4—Timer Status Register 4**H'95****ITU4**

Bit	7	6	5	4	3	2	1	0
	—	—	—	—	—	OVF	IMFB	IMFA
Initial value	1	1	1	1	1	0	0	0
Read/Write	—	—	—	—	—	R/(W)*	R/(W)*	R/(W)*

Notes: Bit functions are the same as for ITU0.

* Only 0 can be written, to clear the flag.

TCNT4 H/L—Timer Counter 4 H/L**H'96, H'97****ITU4**

Bit	15	14	13	12	11	10	9	8	7	6	5	4	3	2	1	0
	<input type="checkbox"/>	<input type="checkbox"/>	<input type="checkbox"/>	<input type="checkbox"/>	<input type="checkbox"/>	<input type="checkbox"/>	<input type="checkbox"/>	<input type="checkbox"/>	<input type="checkbox"/>	<input type="checkbox"/>	<input type="checkbox"/>	<input type="checkbox"/>	<input type="checkbox"/>	<input type="checkbox"/>	<input type="checkbox"/>	<input type="checkbox"/>
Initial value	0	0	0	0	0	0	0	0	0	0	0	0	0	0	0	0
Read/Write	R/W	R/W	R/W	R/W	R/W	R/W	R/W	R/W	R/W	R/W	R/W	R/W	R/W	R/W	R/W	R/W

Note: Bit functions are the same as for ITU3.

GRA4 H/L—General Register A4 H/L**H'98, H'99****ITU4**

Bit	15	14	13	12	11	10	9	8	7	6	5	4	3	2	1	0
	<input type="checkbox"/>	<input type="checkbox"/>	<input type="checkbox"/>	<input type="checkbox"/>	<input type="checkbox"/>	<input type="checkbox"/>	<input type="checkbox"/>	<input type="checkbox"/>	<input type="checkbox"/>	<input type="checkbox"/>	<input type="checkbox"/>	<input type="checkbox"/>	<input type="checkbox"/>	<input type="checkbox"/>	<input type="checkbox"/>	<input type="checkbox"/>
Initial value	1	1	1	1	1	1	1	1	1	1	1	1	1	1	1	1
Read/Write	R/W	R/W	R/W	R/W	R/W	R/W	R/W	R/W	R/W	R/W	R/W	R/W	R/W	R/W	R/W	R/W

Note: Bit functions are the same as for ITU3.

GRB4 H/L—General Register B4 H/L**H'9A, H'9B****ITU4**

Bit	15	14	13	12	11	10	9	8	7	6	5	4	3	2	1	0
	<input type="checkbox"/>	<input type="checkbox"/>	<input type="checkbox"/>	<input type="checkbox"/>	<input type="checkbox"/>	<input type="checkbox"/>	<input type="checkbox"/>	<input type="checkbox"/>	<input type="checkbox"/>	<input type="checkbox"/>	<input type="checkbox"/>	<input type="checkbox"/>	<input type="checkbox"/>	<input type="checkbox"/>	<input type="checkbox"/>	<input type="checkbox"/>
Initial value	1	1	1	1	1	1	1	1	1	1	1	1	1	1	1	1
Read/Write	R/W	R/W	R/W	R/W	R/W	R/W	R/W	R/W	R/W	R/W	R/W	R/W	R/W	R/W	R/W	R/W

Note: Bit functions are the same as for ITU3.

BRA4 H/L—Buffer Register A4 H/L**H'9C, H'9D****ITU4**

Bit	15	14	13	12	11	10	9	8	7	6	5	4	3	2	1	0
	<input type="checkbox"/>	<input type="checkbox"/>	<input type="checkbox"/>	<input type="checkbox"/>	<input type="checkbox"/>	<input type="checkbox"/>	<input type="checkbox"/>	<input type="checkbox"/>	<input type="checkbox"/>	<input type="checkbox"/>	<input type="checkbox"/>	<input type="checkbox"/>	<input type="checkbox"/>	<input type="checkbox"/>	<input type="checkbox"/>	<input type="checkbox"/>
Initial value	1	1	1	1	1	1	1	1	1	1	1	1	1	1	1	1
Read/Write	R/W	R/W	R/W	R/W	R/W	R/W	R/W	R/W	R/W	R/W	R/W	R/W	R/W	R/W	R/W	R/W

Note: Bit functions are the same as for ITU3.

BRB4 H/L—Buffer Register B4 H/L

H'9E, H'9F

ITU4

Bit	15	14	13	12	11	10	9	8	7	6	5	4	3	2	1	0
Initial value	1	1	1	1	1	1	1	1	1	1	1	1	1	1	1	1
Read/Write	R/W	R/W	R/W	R/W	R/W	R/W	R/W	R/W	R/W	R/W	R/W	R/W	R/W	R/W	R/W	R/W

Note: Bit functions are the same as for ITU3.

TPMR—TPC Output Mode Register

H'A0

TPC

Bit	7	6	5	4	3	2	1	0
	—	—	—	—	G3NOV	G2NOV	G1NOV	G0NOV
Initial value	1	1	1	1	0	0	0	0
Read/Write	—	—	—	—	R/W	R/W	R/W	R/W

Group 0 non-overlap

0	Normal TPC output in group 0 Output values change at compare match A in the selected ITU channel
1	Non-overlapping TPC output in group 0, controlled by compare match A and B in the selected ITU channel

Group 1 non-overlap

0	Normal TPC output in group 1 Output values change at compare match A in the selected ITU channel
1	Non-overlapping TPC output in group 1, controlled by compare match A and B in the selected ITU channel

Group 2 non-overlap

0	Normal TPC output in group 2 Output values change at compare match A in the selected ITU channel
1	Non-overlapping TPC output in group 2, controlled by compare match A and B in the selected ITU channel

Group 3 non-overlap

0	Normal TPC output in group 3 Output values change at compare match A in the selected ITU channel
1	Non-overlapping TPC output in group 3, controlled by compare match A and B in the selected ITU channel

TPCR—TPC Output Control Register

H'A1

TPC

Bit	7	6	5	4	3	2	1	0
	G3CMS1	G3CMS0	G2CMS1	G2CMS0	G1CMS1	G1CMS0	G0CMS1	G0CMS0
Initial value	1	1	1	1	1	1	1	1
Read/Write	R/W	R/W	R/W	R/W	R/W	R/W	R/W	R/W

Group 0 compare match select 1 and 0

Bit 1	Bit 0	
G0CMS1	G0CMS0	ITU Channel Selected as Output Trigger
0	0	TPC output group 0 (TP ₃ to TP ₀) is triggered by compare match in ITU channel 0
	1	TPC output group 0 (TP ₃ to TP ₀) is triggered by compare match in ITU channel 1
1	0	TPC output group 0 (TP ₃ to TP ₀) is triggered by compare match in ITU channel 2
	1	TPC output group 0 (TP ₃ to TP ₀) is triggered by compare match in ITU channel 3

Group 1 compare match select 1 and 0

Bit 3	Bit 2	
G1CMS1	G1CMS0	ITU Channel Selected as Output Trigger
0	0	TPC output group 1 (TP ₇ to TP ₄) is triggered by compare match in ITU channel 0
	1	TPC output group 1 (TP ₇ to TP ₄) is triggered by compare match in ITU channel 1
1	0	TPC output group 1 (TP ₇ to TP ₄) is triggered by compare match in ITU channel 2
	1	TPC output group 1 (TP ₇ to TP ₄) is triggered by compare match in ITU channel 3

Group 2 compare match select 1 and 0

Bit 5	Bit 4	
G2CMS1	G2CMS0	ITU Channel Selected as Output Trigger
0	0	TPC output group 2 (TP ₁₁ to TP ₈) is triggered by compare match in ITU channel 0
	1	TPC output group 2 (TP ₁₁ to TP ₈) is triggered by compare match in ITU channel 1
1	0	TPC output group 2 (TP ₁₁ to TP ₈) is triggered by compare match in ITU channel 2
	1	TPC output group 2 (TP ₁₁ to TP ₈) is triggered by compare match in ITU channel 3

Group 3 compare match select 1 and 0

Bit 7	Bit 6	
G3CMS1	G3CMS0	ITU Channel Selected as Output Trigger
0	0	TPC output group 3 (TP ₁₅ to TP ₁₂) is triggered by compare match in ITU channel 0
	1	TPC output group 3 (TP ₁₅ to TP ₁₂) is triggered by compare match in ITU channel 1
1	0	TPC output group 3 (TP ₁₅ to TP ₁₂) is triggered by compare match in ITU channel 2
	1	TPC output group 3 (TP ₁₅ to TP ₁₂) is triggered by compare match in ITU channel 3

NDERB—Next Data Enable Register B**H'A2****TPC**

Bit	7	6	5	4	3	2	1	0
	NDER15	NDER14	NDER13	NDER12	NDER11	NDER10	NDER9	NDER8
Initial value	0	0	0	0	0	0	0	0
Read/Write	R/W	R/W	R/W	R/W	R/W	R/W	R/W	R/W

Next data enable 15 to 8

Bits 7 to 0	
NDER15 to NDER8	Description
0	TPC outputs TP ₁₅ to TP ₈ are disabled (NDR15 to NDR8 are not transferred to PB ₇ to PB ₀)
1	TPC outputs TP ₁₅ to TP ₈ are enabled (NDR15 to NDR8 are transferred to PB ₇ to PB ₀)

NDERA—Next Data Enable Register A**H'A3****TPC**

Bit	7	6	5	4	3	2	1	0
	NDER7	NDER6	NDER5	NDER4	NDER3	NDER2	NDER1	NDER0
Initial value	0	0	0	0	0	0	0	0
Read/Write	R/W	R/W	R/W	R/W	R/W	R/W	R/W	R/W

Next data enable 7 to 0

Bits 7 to 0	
NDER7 to NDER0	Description
0	TPC outputs TP ₇ to TP ₀ are disabled (NDR7 to NDR0 are not transferred to PA ₇ to PA ₀)
1	TPC outputs TP ₇ to TP ₀ are enabled (NDR7 to NDR0 are transferred to PA ₇ to PA ₀)

NDRB—Next Data Register B**H'A4/H'A6****TPC**

- Same trigger for TPC output groups 2 and 3

— Address H'FFA4

Bit	7	6	5	4	3	2	1	0
	NDR15	NDR14	NDR13	NDR12	NDR11	NDR10	NDR9	NDR8
Initial value	0	0	0	0	0	0	0	0
Read/Write	R/W	R/W	R/W	R/W	R/W	R/W	R/W	R/W

Store the next output data for
TPC output group 3
 Store the next output data for
TPC output group 2

— Address H'FFA6

Bit	7	6	5	4	3	2	1	0
	—	—	—	—	—	—	—	—
Initial value	1	1	1	1	1	1	1	1
Read/Write	—	—	—	—	—	—	—	—

- Different triggers for TPC output groups 2 and 3

— Address H'FFA4

Bit	7	6	5	4	3	2	1	0
	NDR15	NDR14	NDR13	NDR12	—	—	—	—
Initial value	0	0	0	0	1	1	1	1
Read/Write	R/W	R/W	R/W	R/W	—	—	—	—

Store the next output data for
TPC output group 3

— Address H'FFA6

Bit	7	6	5	4	3	2	1	0
	—	—	—	—	NDR11	NDR10	NDR9	NDR8
Initial value	1	1	1	1	0	0	0	0
Read/Write	—	—	—	—	R/W	R/W	R/W	R/W

Store the next output data for
TPC output group 2

NDRA—Next Data Register A

H'A5/H'A7

TPC

- Same trigger for TPC output groups 0 and 1

— Address H'FFA5

Bit	7	6	5	4	3	2	1	0
	NDR7	NDR6	NDR5	NDR4	NDR3	NDR2	NDR1	NDR0
Initial value	0	0	0	0	0	0	0	0
Read/Write	R/W	R/W	R/W	R/W	R/W	R/W	R/W	R/W

Store the next output data for TPC output group 1
 Store the next output data for TPC output group 0

— Address H'FFA7

Bit	7	6	5	4	3	2	1	0
	—	—	—	—	—	—	—	—
Initial value	1	1	1	1	1	1	1	1
Read/Write	—	—	—	—	—	—	—	—

- Different triggers for TPC output groups 0 and 1

— Address H'FFA5

Bit	7	6	5	4	3	2	1	0
	NDR7	NDR6	NDR5	NDR4	—	—	—	—
Initial value	0	0	0	0	1	1	1	1
Read/Write	R/W	R/W	R/W	R/W	—	—	—	—

Store the next output data for TPC output group 1

— Address H'FFA7

Bit	7	6	5	4	3	2	1	0
	—	—	—	—	NDR3	NDR2	NDR1	NDR0
Initial value	1	1	1	1	0	0	0	0
Read/Write	—	—	—	—	R/W	R/W	R/W	R/W

Store the next output data for TPC output group 0

TCSR—Timer Control/Status Register

H'A8

WDT

Bit	7	6	5	4	3	2	1	0
	OVF	WT/ \overline{IT}	TME	—	—	CKS2	CKS1	CKS0
Initial value	0	0	0	1	1	0	0	0
Read/Write	R/(W)*	R/W	R/W	—	—	R/W	R/W	R/W

Timer enable

0	Timer disabled
	• TCNT is initialized to H'00 and halted
1	Timer enabled
	• TCNT is counting
	• CPU interrupt requests are enabled

Timer mode select

0	Interval timer: requests interval timer interrupts
1	Watchdog timer: generates a reset signal

Clock select 2 to 0

0	0	0	$\phi/2$
		1	$\phi/32$
	1	0	$\phi/64$
1	0	1	$\phi/128$
		0	$\phi/256$
	1	0	$\phi/512$
		1	$\phi/2048$
		1	$\phi/4096$

Overflow flag

0	[Clearing condition] Read OVF when OVF = 1, then write 0 in OVF
1	[Setting condition] TCNT changes from H'FF to H'00

Note: * Only 0 can be written, to clear the flag.

TCNT—Timer Counter**H'A9 (read),
H'A8 (write)****WDT**

Bit	7	6	5	4	3	2	1	0
Initial value	0	0	0	0	0	0	0	0
Read/Write	R/W	R/W	R/W	R/W	R/W	R/W	R/W	R/W

Count value

RSTCSR—Reset Control/Status Register**H'AB (read),
H'AA (write)****WDT**

Bit	7	6	5	4	3	2	1	0
Initial value	0	0	1	1	1	1	1	1
Read/Write	R/(W)*	R/W	—	—	—	—	—	—

Reset output enable

0	External output of reset signal is disabled
1	External output of reset signal is enabled

Watchdog timer reset

0	[Clearing conditions] • Reset signal input at $\overline{\text{RES}}$ pin • When WRST = 1, write 0 after reading WRST flag
1	[Setting condition] TCNT overflow generates a reset signal

Note: * Only 0 can be written in bit 7, to clear the flag.

H8/3048F-ONE	Not include this register
H8/3048B mask ROM version H8/3048F H8/3048ZTAT H8/3048 mask ROM version H8/3047 mask ROM version H8/3045 mask ROM version H8/3044 mask ROM version	Include this register

RSTCSR—Reset Control/Status Register**H'AB (read),
H'AA (write)****WDT**

Bit	7	6	5	4	3	2	1	0
	WRST	—	—	—	—	—	—	—
Initial value	0	0	1	1	1	1	1	1
Read/Write	R/(W)*1	—*2	—	—	—	—	—	—

Watchdog timer reset

0	[Clearing conditions] • Reset signal input at $\overline{\text{RES}}$ pin • When WRST = 1, write 0 after reading WRST flag
1	[Setting condition] TCNT overflow generates a reset signal

- Notes: 1. Only 0 can be written in bit 7, to clear the flag.
2. Bit 6 must not be set to 1; in a write, 0 must always be written in this bit.

H8/3048F-ONE	Include this register
H8/3048B mask ROM version H8/3048F H8/3048ZTAT H8/3048 mask ROM version H8/3047 mask ROM version H8/3045 mask ROM version H8/3044 mask ROM version	Not include this register

RFSHCR—Refresh Control Register

H'AC Refresh controller

Bit	7	6	5	4	3	2	1	0
	SRFMD	PSRAME	DRAME	CAS/ \overline{WE}	M9/ $\overline{M8}$	RFSHE	—	RCYCE
Initial value	0	0	0	0	0	0	1	0
Read/Write	R/W	R/W	R/W	R/W	R/W	R/W	—	R/W

Refresh cycle enable

0	Refresh cycles are disabled
1	Refresh cycles are enabled for area 3

Refresh pin enable

0	Refresh signal output at the \overline{RFSH} pin is disabled
1	Refresh signal output at the \overline{RFSH} pin is enabled

Address multiplex mode select

0	8-bit column mode
1	9-bit column mode

Strobe mode select

0	2 \overline{WE} mode
1	2 \overline{CAS} mode

PSRAM enable, DRAM enable

Bit 6	Bit 5	RAM Interface
PSRAME	DRAME	
0	0	Can be used as an interval timer (DRAM and PSRAM cannot be directly connected)
	1	DRAM can be directly connected
1	0	PSRAM can be directly connected
	1	Illegal setting

Self-refresh mode

0	DRAM or PSRAM self-refresh is disabled in software standby mode
1	DRAM or PSRAM self-refresh is enabled in software standby mode

RTMCSR—Refresh Timer Control/Status Register

H'AD

Refresh controller

Bit	7	6	5	4	3	2	1	0
	CMF	CMIE	CKS2	CKS1	CKS0	—	—	—
Initial value	0	0	0	0	0	1	1	1
Read/Write	R/(W)*	R/W	R/W	R/W	R/W	—	—	—

Clock select 2 to 0

Bit 5	Bit 4	Bit 3	Counter Clock Source
CKS2	CKS1	CKS0	
0	0	0	Clock input is disabled
		1	$\phi/2$
	1	0	$\phi/8$
		1	$\phi/32$
1	0	0	$\phi/128$
		1	$\phi/512$
	1	0	$\phi/2048$
		1	$\phi/4096$

Compare match interrupt enable

0	The CMI interrupt requested by CMF is disabled
1	The CMI interrupt requested by CMF is enabled

Compare match flag

0	[Clearing condition] Read CMF when CMF = 1, then write 0 in CMF
1	[Setting condition] RTCNT = RTCOR

Note: * Only 0 can be written, to clear the flag.

RTCNT—Refresh Timer Counter**H'AE****Refresh controller**

Bit	7	6	5	4	3	2	1	0
Initial value	0	0	0	0	0	0	0	0
Read/Write	R/W	R/W	R/W	R/W	R/W	R/W	R/W	R/W

|
Count value

RTCOR—Refresh Time Constant Register**H'AF****Refresh controller**

Bit	7	6	5	4	3	2	1	0
Initial value	1	1	1	1	1	1	1	1
Read/Write	R/W	R/W	R/W	R/W	R/W	R/W	R/W	R/W

|
Interval at which RTCNT and compare match are set

SMR—Serial Mode Register

H'B0

SCIO

Bit	7	6	5	7	3	2	1	0
	C/ \bar{A} or GM*	CHR	PE	O/ \bar{E}	STOP	MP	CKS1	CKS0
Initial value	0	0	0	0	0	0	0	0
Read/Write	R/W	R/W	R/W	R/W	R/W	R/W	R/W	R/W

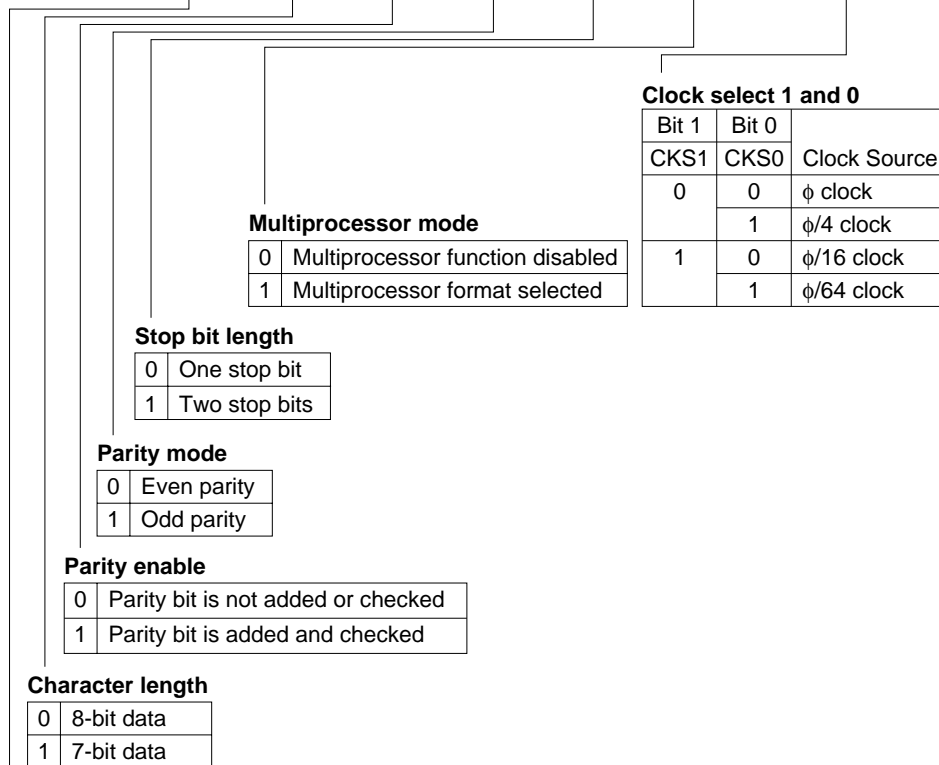

**Communication mode
(when using a serial communication interface)**

0	Asynchronous mode
1	Synchronous mode

GSM mode (when using a smart card interface)

0	Regular smart card interface operation
1	GSM mode smart card interface operation

Note: * The function of this bit differs for the normal serial communication interface and for the smart card interface. Its function is switched with the SMIF bit in SCMR.

BRR—Bit Rate Register**H'B1****SCI0**

Bit	7	6	5	4	3	2	1	0
Initial value	1	1	1	1	1	1	1	1
Read/Write	R/W	R/W	R/W	R/W	R/W	R/W	R/W	R/W

Serial communication bit rate setting

SCR—Serial Control Register

H'B2

SCIO

Bit	7	6	5	4	3	2	1	0
	TIE	RIE	TE	RE	MPIE	TEIE	CKE1	CKE0
Initial value	0	0	0	0	0	0	0	0
Read/Write	R/W	R/W	R/W	R/W	R/W	R/W	R/W	R/W

Clock enable 1 and 0

Bit 1	Bit 0	Clock Selection and Output	
CKE1	CKE0		
0	0	Asynchronous mode	Internal clock, SCK pin available for generic I/O
		Synchronous mode	Internal clock, SCK pin used for serial clock output
	1	Asynchronous mode	Internal clock, SCK pin used for clock output
		Synchronous mode	Internal clock, SCK pin used for serial clock output
1	0	Asynchronous mode	External clock, SCK pin used for clock input
		Synchronous mode	External clock, SCK pin used for serial clock input
	1	Asynchronous mode	External clock, SCK pin used for clock input
		Synchronous mode	External clock, SCK pin used for serial clock input

Transmit-end interrupt enable

0	Transmit-end interrupt requests (TEI) are disabled
1	Transmit-end interrupt requests (TEI) are enabled

Multiprocessor interrupt enable

0	Multiprocessor interrupts are disabled (normal receive operation)
1	Multiprocessor interrupts are enabled

Transmit enable

0	Transmitting is disabled
1	Transmitting is enabled

Receive enable

0	Receiving is disabled
1	Receiving is enabled

Receive interrupt enable

0	Receive-data-full (RXI) and receive-error (ERI) interrupt requests are disabled
1	Receive-data-full (RXI) and receive-error (ERI) interrupt requests are enabled

Transmit interrupt enable

0	Transmit-data-empty interrupt request (TXI) is disabled
1	Transmit-data-empty interrupt request (TXI) is enabled

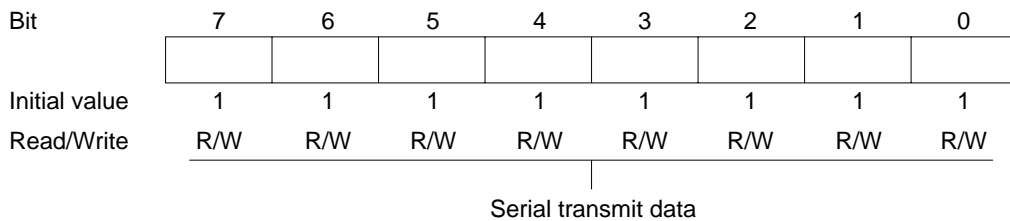
TDR—Transmit Data Register**H'B3****SCI0**

SSR—Serial Status Register

H'B4

SCIO

Bit	7	6	5	4	3	2	1	0
	TDRE	RDRF	ORER	FER/ERS	PER	TEND	MPB	MPBT
Initial value	1	0	0	0	0	1	0	0
Read/Write	R/(W)*	R/(W)*	R/(W)*	R/(W)*	R/(W)*	R	R	R/W

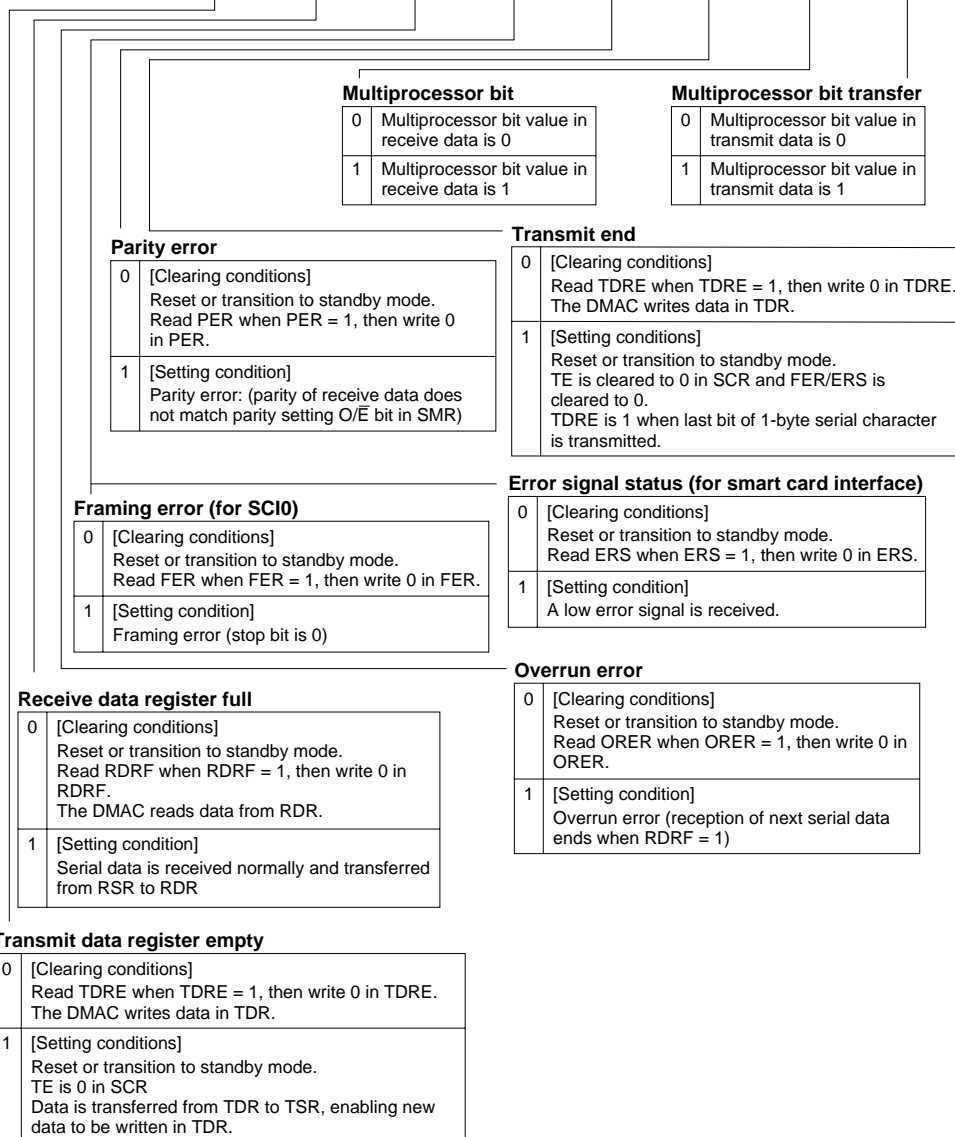

Note: * Only 0 can be written, to clear the flag.

RDR—Receive Data Register**H'B5****SCIO**

Bit	7	6	5	4	3	2	1	0
Initial value	0	0	0	0	0	0	0	0
Read/Write	R	R	R	R	R	R	R	R

Serial receive data

SCMR—Smart Card Mode Register**H'B6****SCIO**

Bit	7	6	5	4	3	2	1	0
Initial value	—	—	—	—	SDIR	SINV	—	SMIF
Read/Write	—	—	—	—	R/W	R/W	—	R/W

Smart card interface mode select

0	Smart card interface function is disabled (Initial value)
1	Smart card interface function is enabled

Smart card data invert

0	Unmodified TDR contents are transmitted (Initial value) Received data is stored unmodified in RDR
1	Inverted TDR contents are transmitted Received data are inverted before storage in RDR

Smart card data transfer direction

0	TDR contents are transmitted LSB-first (Initial value) Received data is stored LSB-first in RDR
1	TDR contents are transmitted MSB-first Received data is stored MSB-first in RDR

SMR—Serial Mode Register**H'B8****SCI1**

Bit	7	6	5	4	3	2	1	0
	C/ \bar{A}	CHR	PE	O/ \bar{E}	STOP	MP	CKS1	CKS0
Initial value	0	0	0	0	0	0	0	0
Read/Write	R/W	R/W	R/W	R/W	R/W	R/W	R/W	R/W

Note: Bit functions are the same as for SCI0.

BRR—Bit Rate Register**H'B9****SCI1**

Bit	7	6	5	4	3	2	1	0
Initial value	1	1	1	1	1	1	1	1
Read/Write	R/W	R/W	R/W	R/W	R/W	R/W	R/W	R/W

Note: Bit functions are the same as for SCI0.

SCR—Serial Control Register**H'BA****SCI1**

Bit	7	6	5	4	3	2	1	0
	TIE	RIE	TE	RE	MPIE	TEIE	CKE1	CKE0
Initial value	0	0	0	0	0	0	0	0
Read/Write	R/W	R/W	R/W	R/W	R/W	R/W	R/W	R/W

Note: Bit functions are the same as for SCI0.

TDR—Transmit Data Register **H'BB** **SCI1**

Bit	7	6	5	4	3	2	1	0
Initial value	1	1	1	1	1	1	1	1
Read/Write	R/W	R/W	R/W	R/W	R/W	R/W	R/W	R/W

Note: Bit functions are the same as for SCI0.

SSR—Serial Status Register **H'BC** **SCI1**

Bit	7	6	5	4	3	2	1	0
	TDRE	RDRF	ORER	FER	PER	TEND	MPB	MPBT
Initial value	1	0	0	0	0	1	0	0
Read/Write	R/(W)*	R/(W)*	R/(W)*	R/(W)*	R/(W)*	R	R	R/W

Notes: Bit functions are the same as for SCI0.

* Only 0 can be written, to clear the flag.

RDR—Receive Data Register **H'BD** **SCI1**

Bit	7	6	5	4	3	2	1	0
Initial value	0	0	0	0	0	0	0	0
Read/Write	R	R	R	R	R	R	R	R

Note: Bit functions are the same as for SCI0.

P1DDR—Port 1 Data Direction Register**H'C0****Port 1**

Bit	7	6	5	4	3	2	1	0
	P1 ₇ DDR	P1 ₆ DDR	P1 ₅ DDR	P1 ₄ DDR	P1 ₃ DDR	P1 ₂ DDR	P1 ₁ DDR	P1 ₀ DDR
Modes 1 to 4	Initial value	1	1	1	1	1	1	1
	Read/Write	—	—	—	—	—	—	—
Modes 5 to 7	Initial value	0	0	0	0	0	0	0
	Read/Write	W	W	W	W	W	W	W

Port 1 input/output select

0	Generic input pin
1	Generic output pin

P2DDR—Port 2 Data Direction Register**H'C1****Port 2**

Bit	7	6	5	4	3	2	1	0
	P2 ₇ DDR	P2 ₆ DDR	P2 ₅ DDR	P2 ₄ DDR	P2 ₃ DDR	P2 ₂ DDR	P2 ₁ DDR	P2 ₀ DDR
Modes 1 to 4	Initial value	1	1	1	1	1	1	1
	Read/Write	—	—	—	—	—	—	—
Modes 5 to 7	Initial value	0	0	0	0	0	0	0
	Read/Write	W	W	W	W	W	W	W

Port 2 input/output select

0	Generic input pin
1	Generic output pin

P1DR—Port 1 Data Register**H'C2****Port 1**

Bit	7	6	5	4	3	2	1	0
	P1 ₇	P1 ₆	P1 ₅	P1 ₄	P1 ₃	P1 ₂	P1 ₁	P1 ₀
Initial value	0	0	0	0	0	0	0	0
Read/Write	R/W	R/W	R/W	R/W	R/W	R/W	R/W	R/W

Data for port 1 pins

P2DR—Port 2 Data Register**H'C3****Port 2**

Bit	7	6	5	4	3	2	1	0
	P2 ₇	P2 ₆	P2 ₅	P2 ₄	P2 ₃	P2 ₂	P2 ₁	P2 ₀
Initial value	0	0	0	0	0	0	0	0
Read/Write	R/W	R/W	R/W	R/W	R/W	R/W	R/W	R/W

Data for port 2 pins

P3DDR—Port 3 Data Direction Register**H'C4****Port 3**

Bit	7	6	5	4	3	2	1	0
	P3 ₇ DDR	P3 ₆ DDR	P3 ₅ DDR	P3 ₄ DDR	P3 ₃ DDR	P3 ₂ DDR	P3 ₁ DDR	P3 ₀ DDR
Initial value	0	0	0	0	0	0	0	0
Read/Write	W	W	W	W	W	W	W	W

Port 3 input/output select

0	Generic input pin
1	Generic output pin

P4DDR—Port 4 Data Direction Register**H'C5****Port 4**

Bit	7	6	5	4	3	2	1	0
	P4 ₇ DDR	P4 ₆ DDR	P4 ₅ DDR	P4 ₄ DDR	P4 ₃ DDR	P4 ₂ DDR	P4 ₁ DDR	P4 ₀ DDR
Initial value	0	0	0	0	0	0	0	0
Read/Write	W	W	W	W	W	W	W	W

Port 4 input/output select

0	Generic input pin
1	Generic output pin

P3DR—Port 3 Data Register**H'C6****Port 3**

Bit	7	6	5	4	3	2	1	0
	P3 ₇	P3 ₆	P3 ₅	P3 ₄	P3 ₃	P3 ₂	P3 ₁	P3 ₀
Initial value	0	0	0	0	0	0	0	0
Read/Write	R/W	R/W	R/W	R/W	R/W	R/W	R/W	R/W

Data for port 3 pins

P4DR—Port 4 Data Register**H'C7****Port 4**

Bit	7	6	5	4	3	2	1	0
	P4 ₇	P4 ₆	P4 ₅	P4 ₄	P4 ₃	P4 ₂	P4 ₁	P4 ₀
Initial value	0	0	0	0	0	0	0	0
Read/Write	R/W	R/W	R/W	R/W	R/W	R/W	R/W	R/W

Data for port 4 pins

P5DDR—Port 5 Data Direction Register**H'C8****Port 5**

Bit	7	6	5	4	3	2	1	0
	—	—	—	—	P5 ₃ DDR	P5 ₂ DDR	P5 ₁ DDR	P5 ₀ DDR
Modes 1 to 4	Initial value	1	1	1	1	1	1	1
	Read/Write	—	—	—	—	—	—	—
Modes 5 to 7	Initial value	1	1	1	0	0	0	0
	Read/Write	—	—	—	W	W	W	W

Port 5 input/output select

0	Generic input
1	Generic output

P6DDR—Port 6 Data Direction Register**H'C9****Port 6**

Bit	7	6	5	4	3	2	1	0
	—	P6 ₆ DDR	P6 ₅ DDR	P6 ₄ DDR	P6 ₃ DDR	P6 ₂ DDR	P6 ₁ DDR	P6 ₀ DDR
Initial value	1	0	0	0	0	0	0	0
Read/Write	—	W	W	W	W	W	W	W

Port 6 input/output select

0	Generic input
1	Generic output

P5DR—Port 5 Data Register**H'CA****Port 5**

Bit	7	6	5	4	3	2	1	0
	—	—	—	—	P5 ₃	P5 ₂	P5 ₁	P5 ₀
Initial value	1	1	1	1	0	0	0	0
Read/Write	—	—	—	—	R/W	R/W	R/W	R/W

Data for port 5 pins

P6DR—Port 6 Data Register**H'CB****Port 6**

Bit	7	6	5	4	3	2	1	0
	—	P6 ₆	P6 ₅	P6 ₄	P6 ₃	P6 ₂	P6 ₁	P6 ₀
Initial value	1	0	0	0	0	0	0	0
Read/Write	—	R/W	R/W	R/W	R/W	R/W	R/W	R/W

Data for port 6 pins

P8DDR—Port 8 Data Direction Register**H'CD****Port 8**

Bit	7	6	5	4	3	2	1	0
	—	—	—	P8 ₄ DDR	P8 ₃ DDR	P8 ₂ DDR	P8 ₁ DDR	P8 ₀ DDR
Modes 1 to 4	Initial value	1	1	1	0	0	0	0
	Read/Write	—	—	W	W	W	W	W
Modes 5 to 7	Initial value	1	1	0	0	0	0	0
	Read/Write	—	—	W	W	W	W	W

Port 8 input/output select		Port 8 input/output select	
0	Generic input	0	Generic input
1	CS output	1	Generic output

P7DR—Port 7 Data Register**H'CE****Port 7**

Bit	7	6	5	4	3	2	1	0
	P7 ₇	P7 ₆	P7 ₅	P7 ₄	P7 ₃	P7 ₂	P7 ₁	P7 ₀
Initial value	—*	—*	—*	—*	—*	—*	—*	—*
Read/Write	R	R	R	R	R	R	R	R

Read the pin levels for port 7

Note: * Determined by pins P7₇ to P7₀.**P8DR—Port 8 Data Register****H'CF****Port 8**

Bit	7	6	5	4	3	2	1	0
	—	—	—	P8 ₄	P8 ₃	P8 ₂	P8 ₁	P8 ₀
Initial value	1	1	1	0	0	0	0	0
Read/Write	—	—	—	R/W	R/W	R/W	R/W	R/W

Data for port 8 pins

P9DDR—Port 9 Data Direction Register**H'D0****Port 9**

Bit	7	6	5	4	3	2	1	0
	—	—	P9 ₅ DDR	P9 ₄ DDR	P9 ₃ DDR	P9 ₂ DDR	P9 ₁ DDR	P9 ₀ DDR
Initial value	1	1	0	0	0	0	0	0
Read/Write	—	—	W	W	W	W	W	W

Port 9 input/output select

0	Generic input
1	Generic output

PADDR—Port A Data Direction Register**H'D1****Port A**

Bit	7	6	5	4	3	2	1	0
	PA ₇ DDR	PA ₆ DDR	PA ₅ DDR	PA ₄ DDR	PA ₃ DDR	PA ₂ DDR	PA ₁ DDR	PA ₀ DDR
Modes {	Initial value	1	0	0	0	0	0	0
3, 4, 6	Read/Write	—	W	W	W	W	W	W
Modes {	Initial value	0	0	0	0	0	0	0
1, 2, 5, 7	Read/Write	W	W	W	W	W	W	W

Port A input/output select

0	Generic input
1	Generic output

P9DR—Port 9 Data Register**H'D2****Port 9**

Bit	7	6	5	4	3	2	1	0
	—	—	P9 ₅	P9 ₄	P9 ₃	P9 ₂	P9 ₁	P9 ₀
Initial value	1	1	0	0	0	0	0	0
Read/Write	—	—	R/W	R/W	R/W	R/W	R/W	R/W

Data for port 9 pins

PADR—Port A Data Register**H'D3****Port A**

Bit	7	6	5	4	3	2	1	0
	PA ₇	PA ₆	PA ₅	PA ₄	PA ₃	PA ₂	PA ₁	PA ₀
Initial value	0	0	0	0	0	0	0	0
Read/Write	R/W	R/W	R/W	R/W	R/W	R/W	R/W	R/W

|
Data for port A pins

PBDDR—Port B Data Direction Register**H'D4****Port B**

Bit	7	6	5	4	3	2	1	0
	PB ₇ DDR	PB ₆ DDR	PB ₅ DDR	PB ₄ DDR	PB ₃ DDR	PB ₂ DDR	PB ₁ DDR	PB ₀ DDR
Initial value	0	0	0	0	0	0	0	0
Read/Write	W	W	W	W	W	W	W	W

Port B input/output select

0	Generic input
1	Generic output

PBDR—Port B Data Register**H'D6****Port B**

Bit	7	6	5	4	3	2	1	0
	PB ₇	PB ₆	PB ₅	PB ₄	PB ₃	PB ₂	PB ₁	PB ₀
Initial value	0	0	0	0	0	0	0	0
Read/Write	R/W	R/W	R/W	R/W	R/W	R/W	R/W	R/W

|
Data for port B pins

P2PCR—Port 2 Input Pull-Up MOS Control Register**H'D8****Port 2**

Bit	7	6	5	4	3	2	1	0
	P2 ₇ PCR	P2 ₆ PCR	P2 ₅ PCR	P2 ₄ PCR	P2 ₃ PCR	P2 ₂ PCR	P2 ₁ PCR	P2 ₀ PCR
Initial value	0	0	0	0	0	0	0	0
Read/Write	R/W	R/W	R/W	R/W	R/W	R/W	R/W	R/W

Port 2 input pull-up MOS control 7 to 0

0	Input pull-up transistor is off
1	Input pull-up transistor is on

Note: Valid when the corresponding P2DDR bit is cleared to 0 (designating generic input).

P4PCR—Port 4 Input Pull-Up MOS Control Register**H'DA****Port 4**

Bit	7	6	5	4	3	2	1	0
	P4 ₇ PCR	P4 ₆ PCR	P4 ₅ PCR	P4 ₄ PCR	P4 ₃ PCR	P4 ₂ PCR	P4 ₁ PCR	P4 ₀ PCR
Initial value	0	0	0	0	0	0	0	0
Read/Write	R/W	R/W	R/W	R/W	R/W	R/W	R/W	R/W

Port 4 input pull-up MOS control 7 to 0

0	Input pull-up transistor is off
1	Input pull-up transistor is on

Note: Valid when the corresponding P4DDR bit is cleared to 0 (designating generic input).

P5PCR—Port 5 Input Pull-Up MOS Control Register**H'DB****Port 5**

Bit	7	6	5	4	3	2	1	0
	—	—	—	—	P5 ₃ PCR	P5 ₂ PCR	P5 ₁ PCR	P5 ₀ PCR
Initial value	1	1	1	1	0	0	0	0
Read/Write	—	—	—	—	R/W	R/W	R/W	R/W

Port 5 input pull-up MOS control 3 to 0

0	Input pull-up transistor is off
1	Input pull-up transistor is on

Note: Valid when the corresponding P5DDR bit is cleared to 0 (designating generic input).

DADR0—D/A Data Register 0**H'DC****D/A**

Bit	7	6	5	4	3	2	1	0
Initial value	0	0	0	0	0	0	0	0
Read/Write	R/W	R/W	R/W	R/W	R/W	R/W	R/W	R/W

D/A conversion data

DADR1—D/A Data Register 1**H'DD****D/A**

Bit	7	6	5	4	3	2	1	0
Initial value	0	0	0	0	0	0	0	0
Read/Write	R/W	R/W	R/W	R/W	R/W	R/W	R/W	R/W

D/A conversion data

DACR—D/A Control Register

H'DE

D/A

Bit	7	6	5	4	3	2	1	0
	DAOE1	DAOE0	DAE	—	—	—	—	—
Initial value	0	0	0	1	1	1	1	1
Read/Write	R/W	R/W	R/W	—	—	—	—	—

D/A enable

Bit 7	Bit 6	Bit 5	Description
DAOE1	DAOE0	DAE	
0	0	—	D/A conversion is disabled in channels 0 and 1
		1	D/A conversion is enabled in channel 0 D/A conversion is disabled in channel 1
	1	D/A conversion is enabled in channels 0 and 1	
1	0	0	D/A conversion is disabled in channel 0 D/A conversion is enabled in channel 1
		1	D/A conversion is enabled in channels 0 and 1
	1	—	D/A conversion is enabled in channels 0 and 1

D/A output enable 0

0	DA ₀ analog output is disabled
1	Channel-0 D/A conversion and DA ₀ analog output are enabled

D/A output enable 1

0	DA ₁ analog output is disabled
1	Channel-1 D/A conversion and DA ₁ analog output are enabled

ADDRA H/L—A/D Data Register A H/L

H'E0, H'E1

A/D

Bit	15	14	13	12	11	10	9	8	7	6	5	4	3	2	1	0
	AD9	AD8	AD7	AD6	AD5	AD4	AD3	AD2	AD1	AD0	—	—	—	—	—	—
Initial value	0	0	0	0	0	0	0	0	0	0	0	0	0	0	0	0
Read/Write	R	R	R	R	R	R	R	R	R	R	R	R	R	R	R	R

ADDRAH

ADDRAL

A/D conversion data
10-bit data giving an
A/D conversion result

ADDRB H/L—A/D Data Register B H/L**H'E2, H'E3****A/D**

Bit	15	14	13	12	11	10	9	8	7	6	5	4	3	2	1	0
	AD9	AD8	AD7	AD6	AD5	AD4	AD3	AD2	AD1	AD0	—	—	—	—	—	—
Initial value	0	0	0	0	0	0	0	0	0	0	0	0	0	0	0	0
Read/Write	R	R	R	R	R	R	R	R	R	R	R	R	R	R	R	R
	ADDRBH								ADDRBL							
	A/D conversion data 10-bit data giving an A/D conversion result															

ADDRC H/L—A/D Data Register C H/L**H'E4, H'E5****A/D**

Bit	15	14	13	12	11	10	9	8	7	6	5	4	3	2	1	0
	AD9	AD8	AD7	AD6	AD5	AD4	AD3	AD2	AD1	AD0	—	—	—	—	—	—
Initial value	0	0	0	0	0	0	0	0	0	0	0	0	0	0	0	0
Read/Write	R	R	R	R	R	R	R	R	R	R	R	R	R	R	R	R
	ADDRCH								ADDRCL							
	A/D conversion data 10-bit data giving an A/D conversion result															

ADDRD H/L—A/D Data Register D H/L**H'E6, H'E7****A/D**

Bit	15	14	13	12	11	10	9	8	7	6	5	4	3	2	1	0
	AD9	AD8	AD7	AD6	AD5	AD4	AD3	AD2	AD1	AD0	—	—	—	—	—	—
Initial value	0	0	0	0	0	0	0	0	0	0	0	0	0	0	0	0
Read/Write	R	R	R	R	R	R	R	R	R	R	R	R	R	R	R	R
	ADDRDH								ADDRDL							
	A/D conversion data 10-bit data giving an A/D conversion result															

ADCSR—A/D Control/Status Register

H'E8

A/D

Bit	7	6	5	4	3	2	1	0
	ADF	ADIE	ADST	SCAN	CKS	CH2	CH1	CH0
Initial value	0	0	0	0	0	0	0	0
Read/Write	R/(W)*	R/W	R/W	R/W	R/W	R/W	R/W	R/W

Clock select

0	Conversion time = 266 states (maximum)
1	Conversion time = 134 states (maximum)

Channel select 2 to 0

Group Selection	Channel Selection		Description	
CH2	CH1	CH0	Single Mode	Scan Mode
0	0	0	AN ₀	AN ₀
		1	AN ₁	AN ₀ , AN ₁
	1	0	AN ₂	AN ₀ to AN ₂
		1	AN ₃	AN ₀ to AN ₃
1	0	0	AN ₄	AN ₄
		1	AN ₅	AN ₄ , AN ₅
	1	0	AN ₆	AN ₄ to AN ₆
		1	AN ₇	AN ₄ to AN ₇

Scan mode

0	Single mode
1	Scan mode

A/D start

0	A/D conversion is stopped
1	Single mode: A/D conversion starts; ADST is automatically cleared to 0 when conversion ends Scan mode: A/D conversion starts and continues, cycling among the selected channels, until ADST is cleared to 0 by software, by a reset, or by a transition to standby mode

A/D interrupt enable

0	A/D end interrupt request is disabled
1	A/D end interrupt request is enabled

A/D end flag

0	[Clearing condition] Read ADF while ADF = 1, then write 0 in ADF
1	[Setting conditions] Single mode: A/D conversion ends Scan mode: A/D conversion ends in all selected channels

Note: * Only 0 can be written, to clear flag.

ADCR—A/D Control Register

H'E9

A/D

Bit	7	6	5	4	3	2	1	0
TRGE	—	—	—	—	—	—	—	—
Initial value	0	1	1	1	1	1	1	1
Read/Write	R/W	—	—	—	—	—	—	—

Trigger enable

0	A/D conversion cannot be externally triggered
1	A/D conversion starts at the fall of the external trigger signal ($\overline{\text{ADTRG}}$)

H8/3048F-ONE	Not include this register
H8/3048F H8/3048B mask ROM version H8/3048ZTAT H8/3048 mask ROM version H8/3047 mask ROM version H8/3045 mask ROM version H8/3044 mask ROM version	Include this register

ADCR—A/D Control Register

H'E9

A/D

Bit	7	6	5	4	3	2	1	0
TRGE	—	—	—	—	—	—	—	—
Initial value	0	1	1	1	1	1	1	0
Read/Write	R/W	—	—	—	—	—	—	—*

Trigger enable

0	A/D conversion cannot be externally triggered
1	A/D conversion starts at the fall of the external trigger signal ($\overline{\text{ADTRG}}$)

Note: * Bit 0 must not be set to 1; in a write, 0 must always be written in this bit.

H8/3048F-ONE	Include this register
H8/3048F H8/3048B mask ROM version H8/3048ZTAT H8/3048 mask ROM version H8/3047 mask ROM version H8/3045 mask ROM version H8/3044 mask ROM version	Not include this register

ABWCR—Bus Width Control Register**H'EC****Bus controller**

Bit	7	6	5	4	3	2	1	0
	ABW7	ABW6	ABW5	ABW4	ABW3	ABW2	ABW1	ABW0
Initial value	Mode 1,3,5,6	1	1	1	1	1	1	1
	Mode 2,4,7	0	0	0	0	0	0	0
Read/Write	R/W	R/W	R/W	R/W	R/W	R/W	R/W	R/W

Area 7 to 0 bus width control

Bits 7 to 0	Bus Width of Access Area
ABW7 to ABW0	
0	Areas 7 to 0 are 16-bit access areas
1	Areas 7 to 0 are 8-bit access areas

ASTCR—Access State Control Register**H'ED****Bus controller**

Bit	7	6	5	4	3	2	1	0
	AST7	AST6	AST5	AST4	AST3	AST2	AST1	AST0
Initial value	1	1	1	1	1	1	1	1
Read/Write	R/W	R/W	R/W	R/W	R/W	R/W	R/W	R/W

Area 7 to 0 access state control

Bits 7 to 0	Number of States in Access Cycle
AST7 to AST0	
0	Areas 7 to 0 are two-state access areas
1	Areas 7 to 0 are three-state access areas

WCR—Wait Control Register**H'EE****Bus controller**

Bit	7	6	5	4	3	2	1	0
	—	—	—	—	WMS1	WMS0	WC1	WC0
Initial value	1	1	1	1	0	0	1	1
Read/Write	—	—	—	—	R/W	R/W	R/W	R/W

Wait mode select 1 and 0

Bit 3	Bit 2	Wait Mode
WMS1	WMS0	
0	0	Programmable wait mode
	1	No wait states inserted by wait-state controller
1	0	Pin wait mode 1
	1	Pin auto-wait mode

Wait count 1 and 0

Bit 1	Bit 0	Number of Wait States
WC1	WC0	
0	0	No wait states inserted by wait-state controller
	1	1 state inserted
1	0	2 states inserted
	1	3 states inserted

WCER—Wait-State Controller Enable Register**H'EF****Bus controller**

Bit	7	6	5	4	3	2	1	0
	WCE7	WCE6	WCE5	WCE4	WCE3	WCE2	WCE1	WCE0
Initial value	1	1	1	1	1	1	1	1
Read/Write	R/W	R/W	R/W	R/W	R/W	R/W	R/W	R/W

Wait-state controller enable 7 to 0

0	Wait-state control is disabled (pin wait mode 0)
1	Wait-state control is enabled

MDCR—Mode Control Register**H'F1****System control**

Bit	7	6	5	4	3	2	1	0
	—	—	—	—	—	MDS2	MDS1	MDS0
Initial value	1	1	0	0	0	—*	—*	—*
Read/Write	—	—	—	—	—	R	R	R

Mode select 2 to 0

Bit 2	Bit 1	Bit 0	Operating mode
MD ₂	MD ₁	MD ₀	
0	0	0	—
		1	Mode 1
	1	0	Mode 2
		1	Mode 3
1	0	0	Mode 4
		1	Mode 5
	1	0	Mode 6
		1	Mode 7

Note: * Determined by the state of the mode pins (MD₂ to MD₀).

SYSCR—System Control Register

H'F2

System control

Bit	7	6	5	4	3	2	1	0
	SSBY	STS2	STS1	STS0	UE	NMIEG	—	RAME
Initial value	0	0	0	0	1	0	1	1
Read/Write	R/W	R/W	R/W	R/W	R/W	R/W	—	R/W

RAM enable	
0	On-chip RAM is disabled
1	On-chip RAM is enabled

NMI edge select	
0	An interrupt is requested at the falling edge of NMI
1	An interrupt is requested at the rising edge of NMI

User bit enable	
0	CCR bit 6 (UI) is used as an interrupt mask bit
1	CCR bit 6 (UI) is used as a user bit

Standby timer select 2 to 0

Bit 6	Bit 5	Bit 4	Standby Timer	
STS2	STS1	STS0	H8/3048F-ONE H8/3048B mask ROM version	*
0	0	0	Waiting time = 8,192 states	Waiting time = 8,192 states
		1	Waiting time = 16,384 states	Waiting time = 16,384 states
	1	0	Waiting time = 32,768 states	Waiting time = 32,768 states
		1	Waiting time = 65,536 states	Waiting time = 65,536 states
1	0	0	Waiting time = 131,072 states	Waiting time = 131,072 states
		1	Waiting time = 262,144 states	Waiting time = 1,024 states
	1	0	Waiting time = 1,024 states	Illegal setting
		1	Illegal setting	Illegal setting

Note: * H8/3048F
H8/3048ZTAT
H8/3048 mask ROM version
H8/3047 mask ROM version
H8/3045 mask ROM version
H8/3044 mask ROM version

Software standby

0	SLEEP instruction causes transition to sleep mode
1	SLEEP instruction causes transition to software standby mode

BRCR—Bus Release Control Register**H'F3****Bus controller**

Bit	7	6	5	4	3	2	1	0
	A23E	A22E	A21E	—	—	—	—	BRLE
Modes 1, 2, 5, 7	Initial value	1	1	1	1	1	1	0
	Read/Write	—	—	—	—	—	—	R/W
Modes 3, 4, 6	Initial value	1	1	1	1	1	1	0
	Read/Write	R/W	R/W	R/W	—	—	—	R/W

Bus release enable

0	The bus cannot be released to an external device
1	The bus can be released to an external device

Address 23 to 21 enable

0	Address output
1	Other input/output

ISCR—IRQ Sense Control Register**H'F4****Interrupt controller**

Bit	7	6	5	4	3	2	1	0
	—	—	IRQ5SC	IRQ4SC	IRQ3SC	IRQ2SC	IRQ1SC	IRQ0SC
Initial value	0	0	0	0	0	0	0	0
Read/Write	R/W	R/W	R/W	R/W	R/W	R/W	R/W	R/W

IRQ₅ to IRQ₀ sense control

0	Interrupts are requested when $\overline{\text{IRQ}}_5$ to $\overline{\text{IRQ}}_0$ inputs are low
1	Interrupts are requested by falling-edge input at $\overline{\text{IRQ}}_5$ to $\overline{\text{IRQ}}_0$

IER—IRQ Enable Register**H'F5 Interrupt controller**

Bit	7	6	5	4	3	2	1	0
	—	—	IRQ5E	IRQ4E	IRQ3E	IRQ2E	IRQ1E	IRQ0E
Initial value	0	0	0	0	0	0	0	0
Read/Write	R/W	R/W	R/W	R/W	R/W	R/W	R/W	R/W

IRQ₅ to IRQ₀ enable

0	IRQ ₅ to IRQ ₀ interrupts are disabled
1	IRQ ₅ to IRQ ₀ interrupts are enabled

ISR—IRQ Status Register**H'F6 Interrupt controller**

Bit	7	6	5	4	3	2	1	0
	—	—	IRQ5F	IRQ4F	IRQ3F	IRQ2F	IRQ1F	IRQ0F
Initial value	0	0	0	0	0	0	0	0
Read/Write	—	—	R/(W)*	R/(W)*	R/(W)*	R/(W)*	R/(W)*	R/(W)*

IRQ₅ to IRQ₀ flags

Bits 5 to 0	
IRQ5F to IRQ0F	Setting and Clearing Conditions
0	[Clearing conditions] Read IRQnF when IRQnF = 1, then write 0 in IRQnF. IRQnSC = 0, $\overline{\text{IRQn}}$ input is high, and interrupt exception handling is carried out. IRQnSC = 1 and IRQn interrupt exception handling is carried out.
1	[Setting conditions] IRQnSC = 0 and $\overline{\text{IRQn}}$ input is low. IRQnSC = 1 and a falling edge is generated in the $\overline{\text{IRQn}}$ input.

(n = 5 to 0)

Note: * Only 0 can be written, to clear the flag.

IPRA—Interrupt Priority Register A**H'F8 Interrupt controller**

Bit	7	6	5	4	3	2	1	0
	IPRA7	IPRA6	IPRA5	IPRA4	IPRA3	IPRA2	IPRA1	IPRA0
Initial value	0	0	0	0	0	0	0	0
Read/Write	R/W	R/W	R/W	R/W	R/W	R/W	R/W	R/W

Priority level A7 to A0

0	Priority level 0 (low priority)
1	Priority level 1 (high priority)

- Interrupt sources controlled by each bit

	Bit 7: IPRA7	Bit 6: IPRA6	Bit 5: IPRA5	Bit 4: IPRA4	Bit 3: IPRA3	Bit 2: IPRA2	Bit 1: IPRA1	Bit 0: IPRA0
Interrupt source	IRQ ₀	IRQ ₁	IRQ ₂ , IRQ ₃	IRQ ₄ , IRQ ₅	WDT, Refresh Controller	ITU channel 0	ITU channel 1	ITU channel 2

IPRB—Interrupt Priority Register B**H'F9 Interrupt controller**

Bit	7	6	5	4	3	2	1	0
	IPRB7	IPRB6	IPRB5	—	IPRB3	IPRB2	IPRB1	—
Initial value	0	0	0	0	0	0	0	0
Read/Write	R/W	R/W	R/W	R/W	R/W	R/W	R/W	R/W

Priority level B7 to B5, B3 to B 1

0	Priority level 0 (low priority)
1	Priority level 1 (high priority)

- Interrupt sources controlled by each bit

	Bit 7: IPRB7	Bit 6: IPRB6	Bit 5: IPRB5	Bit 4: —	Bit 3: IPRB3	Bit 2: IPRB2	Bit 1: IPRB1	Bit 0: —
Interrupt source	ITU channel 3	ITU channel 4	DMAC	—	SCI channel 0	SCI channel 1	A/D converter	—

C.2 Port 2 Block Diagram

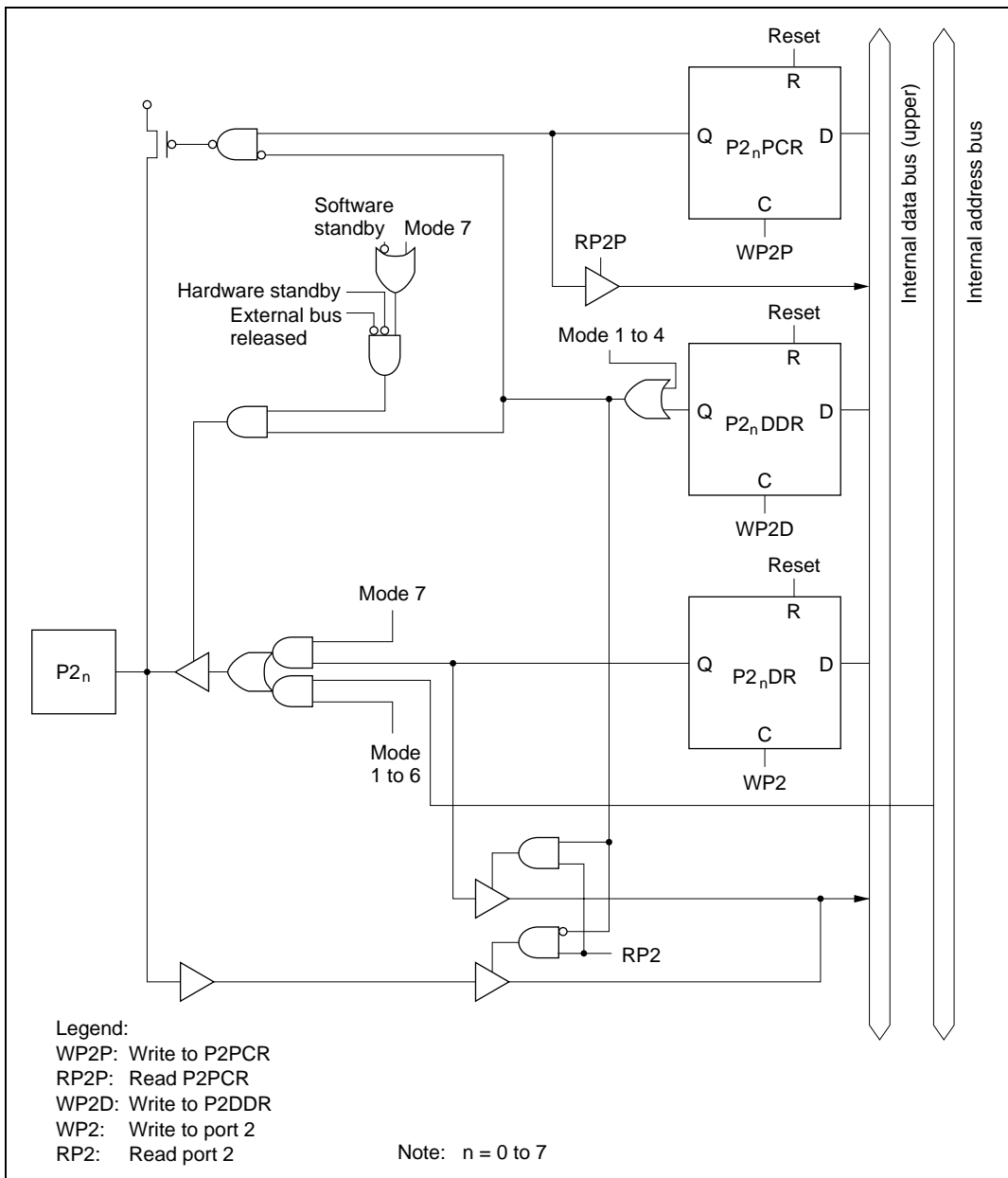

Figure C.2 Port 2 Block Diagram (Pins $P2_0$ to $P2_7$)

C.3 Port 3 Block Diagram

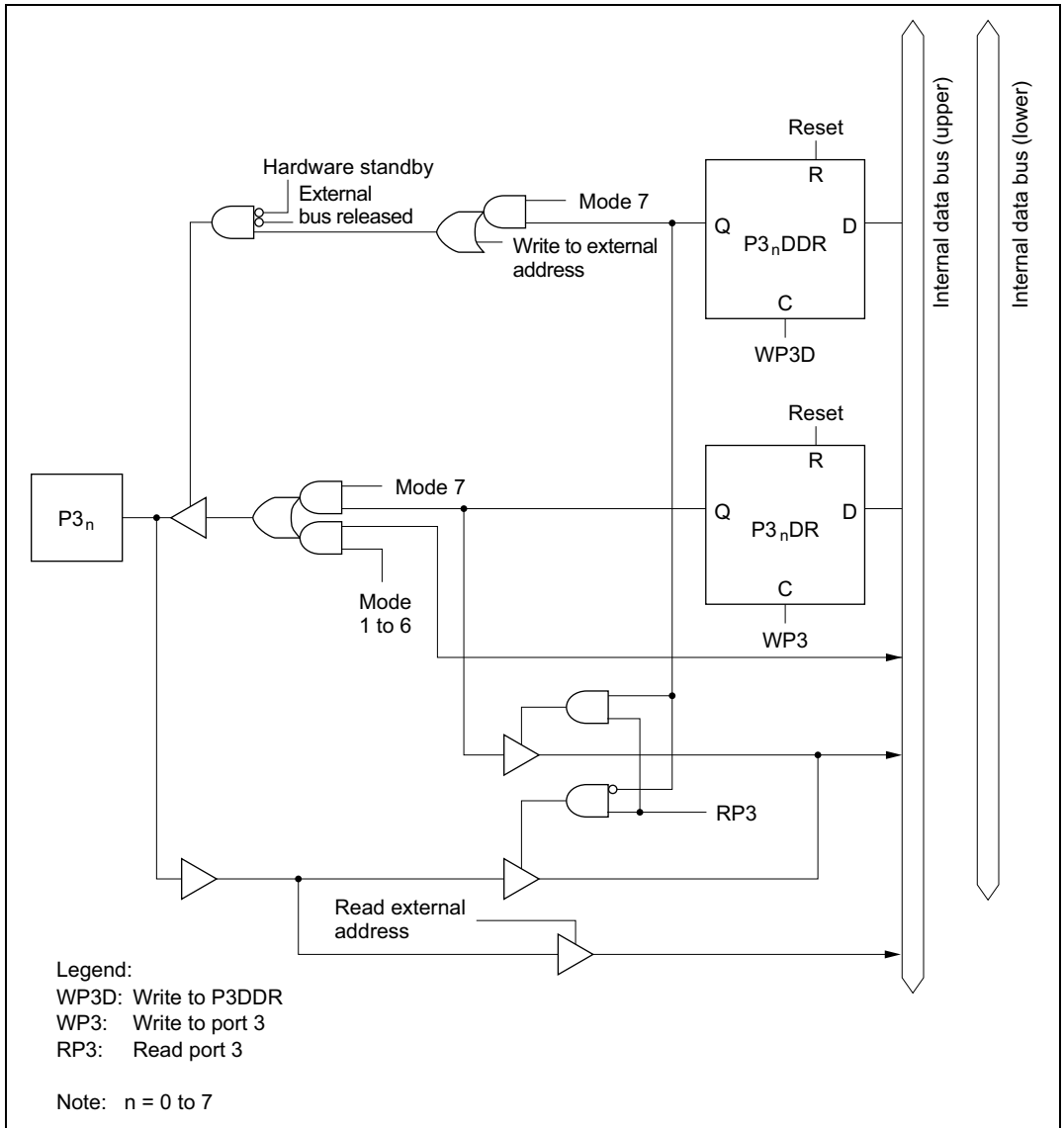

Figure C.3 Port 3 Block Diagram (Pins $P3_0$ to $P3_7$)

C.4 Port 4 Block Diagram

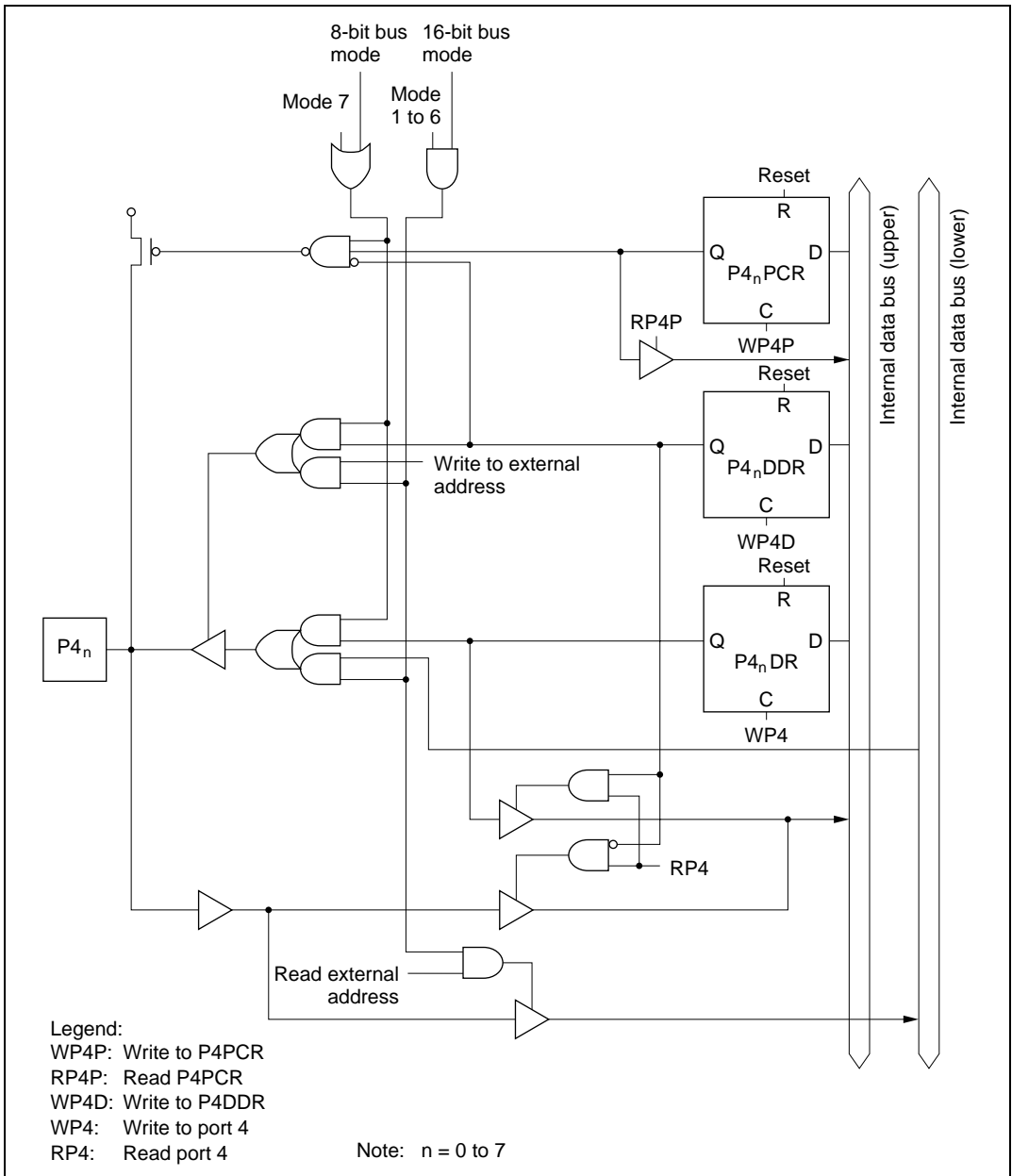

Figure C.4 Port 4 Block Diagram (Pins $P4_0$ to $P4_7$)

C.5 Port 5 Block Diagram

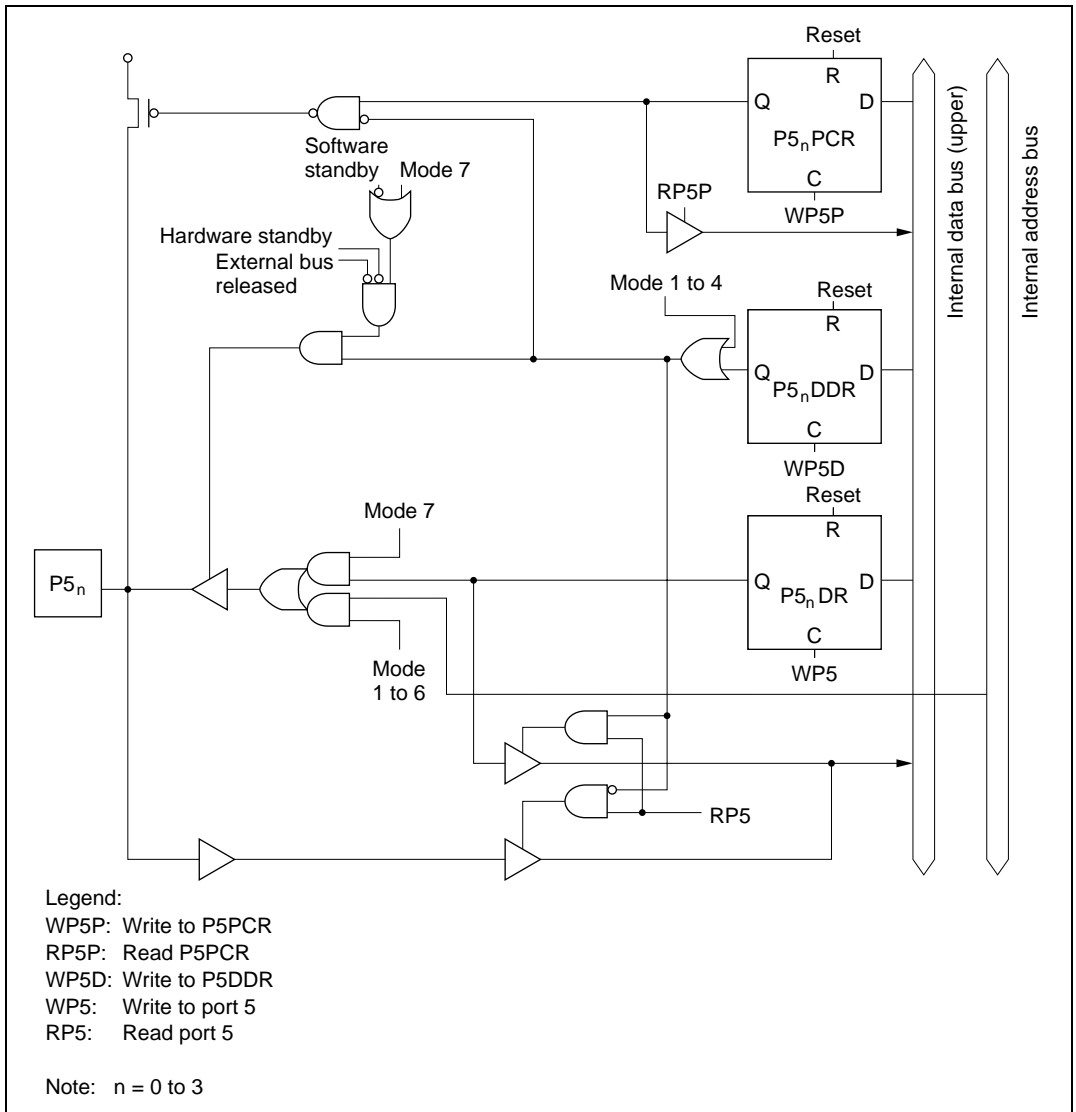
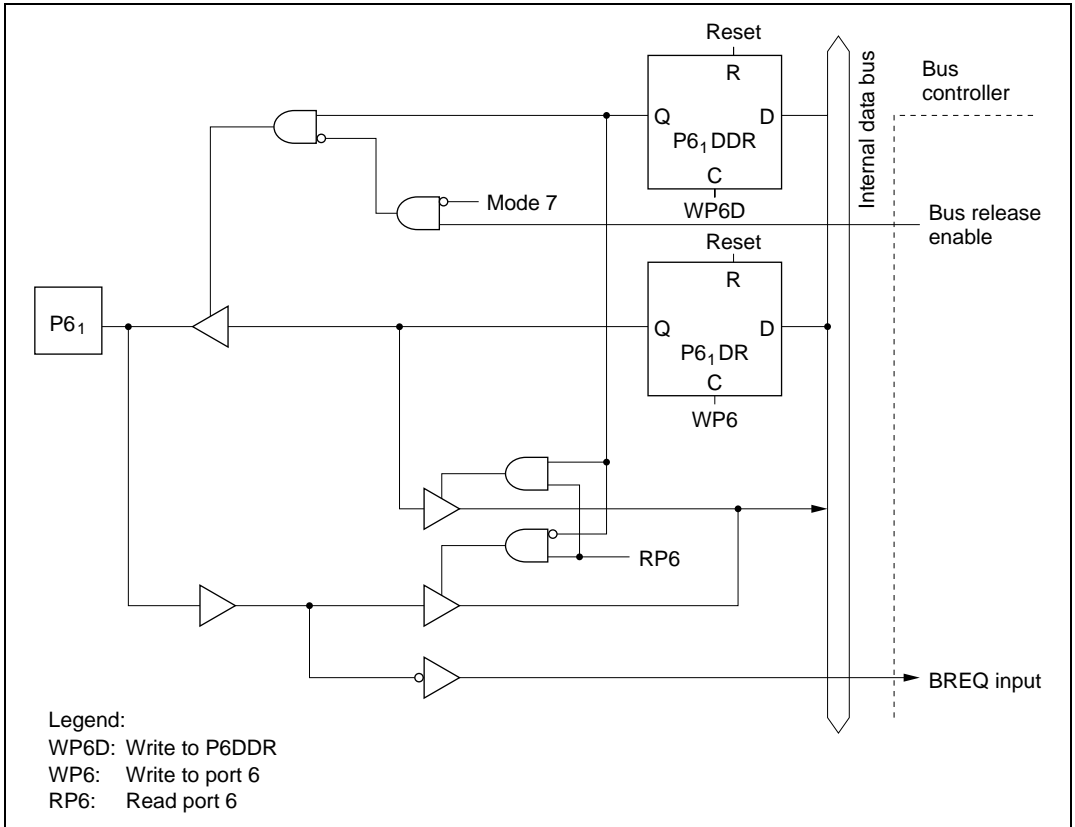
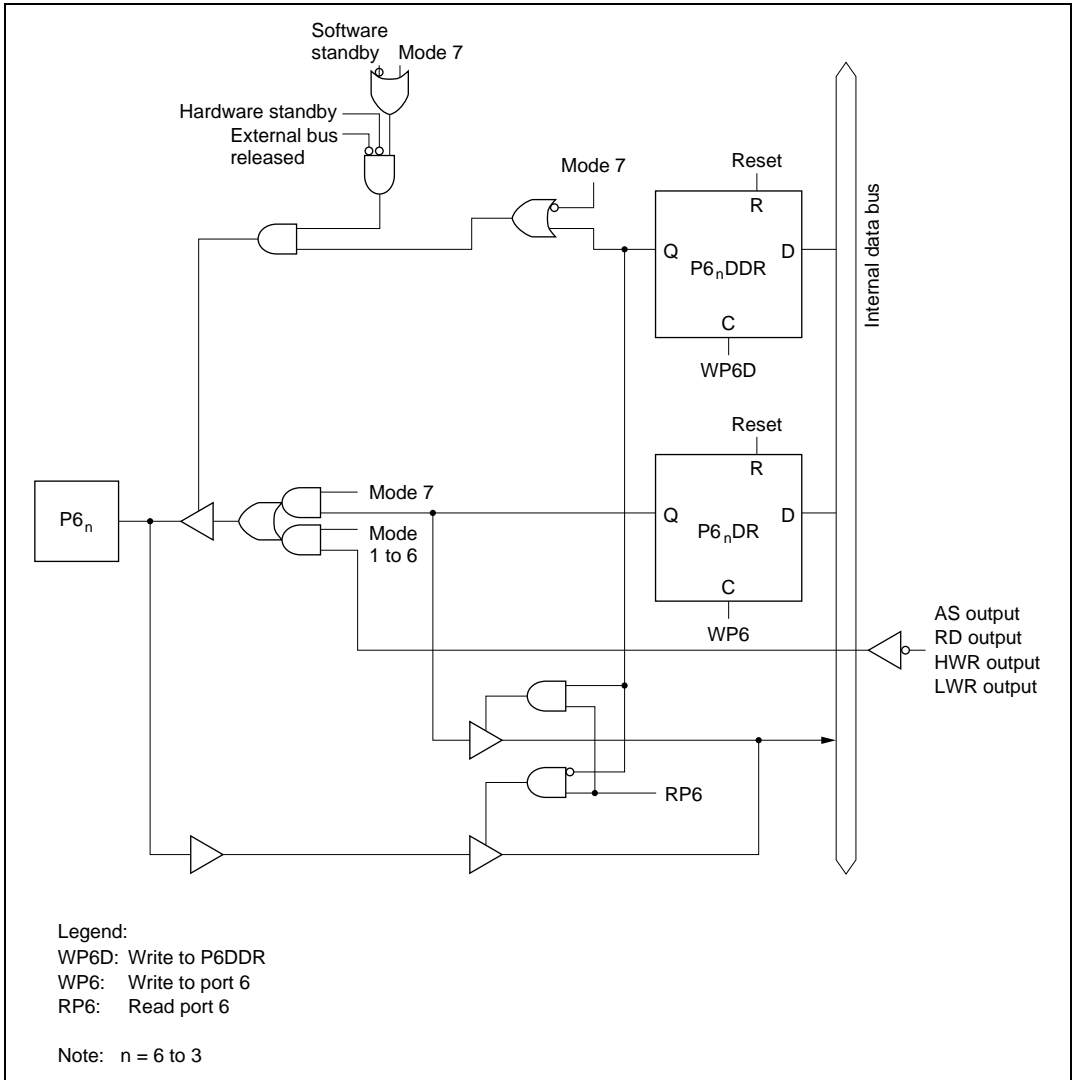

Figure C.5 Port 5 Block Diagram (Pins P5₀ to P5₃)

Figure C.6 (b) Port 6 Block Diagram (Pin P6₁)

Figure C.6 (d) Port 6 Block Diagram (Pins $P6_n$ to $P6_3$)

C.7 Port 7 Block Diagrams

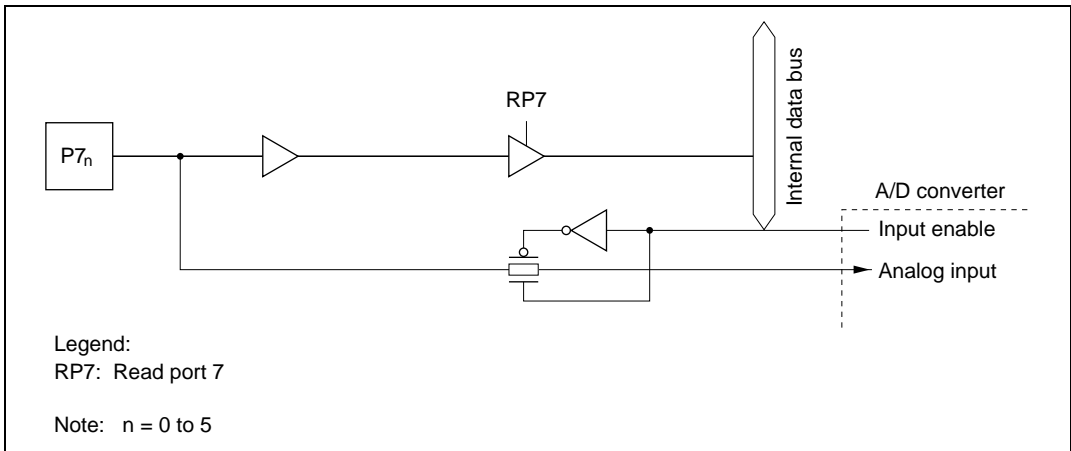

Figure C.7 (a) Port 7 Block Diagram (Pins P7₀ to P7₅)

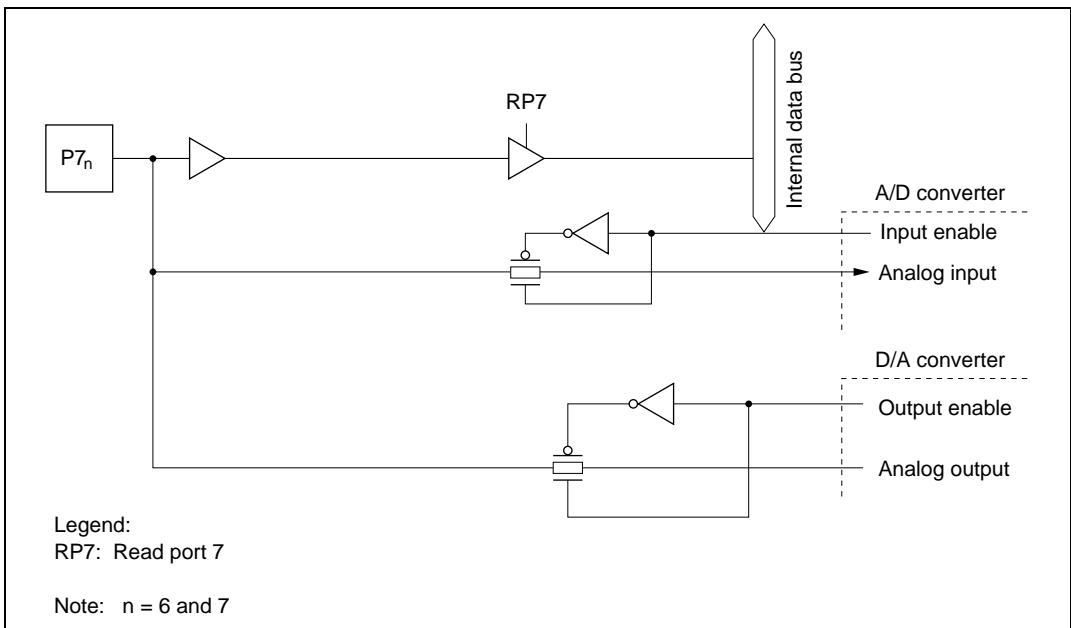

Figure C.7 (b) Port 7 Block Diagram (Pins P7₆ and P7₇)

C.8 Port 8 Block Diagrams

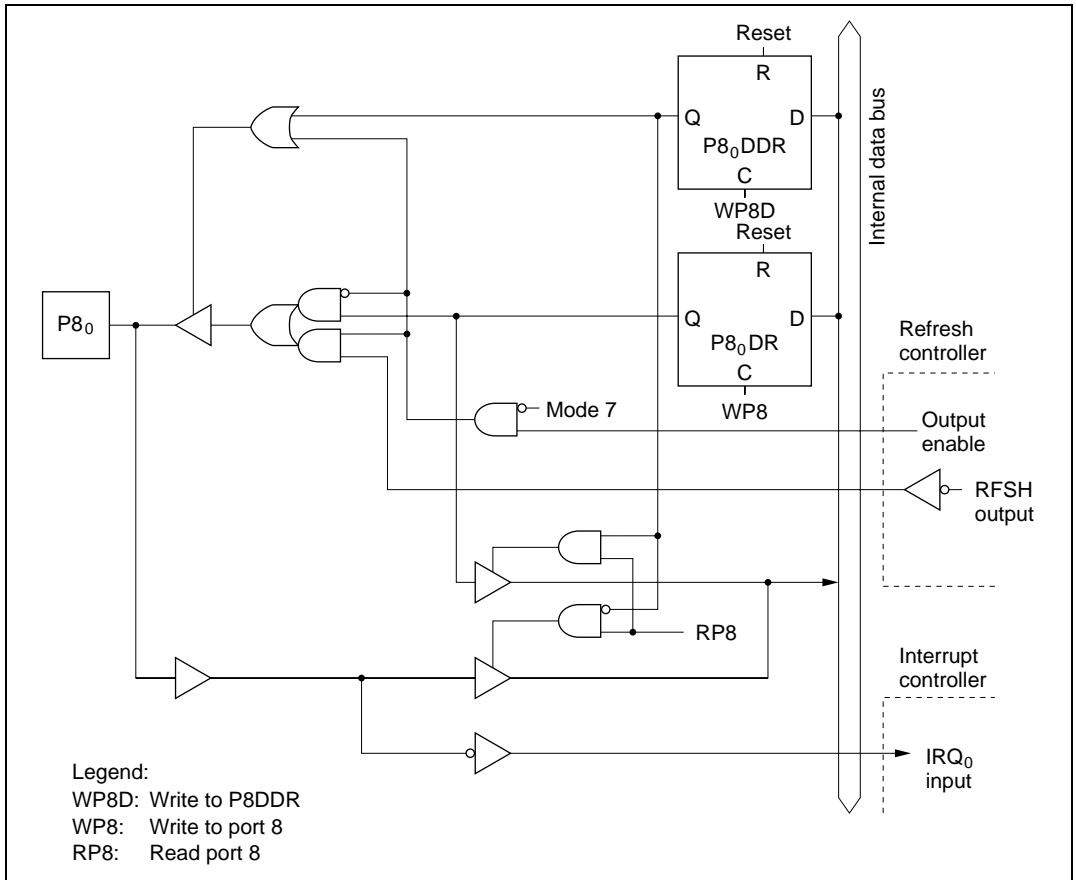

Figure C.8 (a) Port 8 Block Diagram (Pin P8₀)

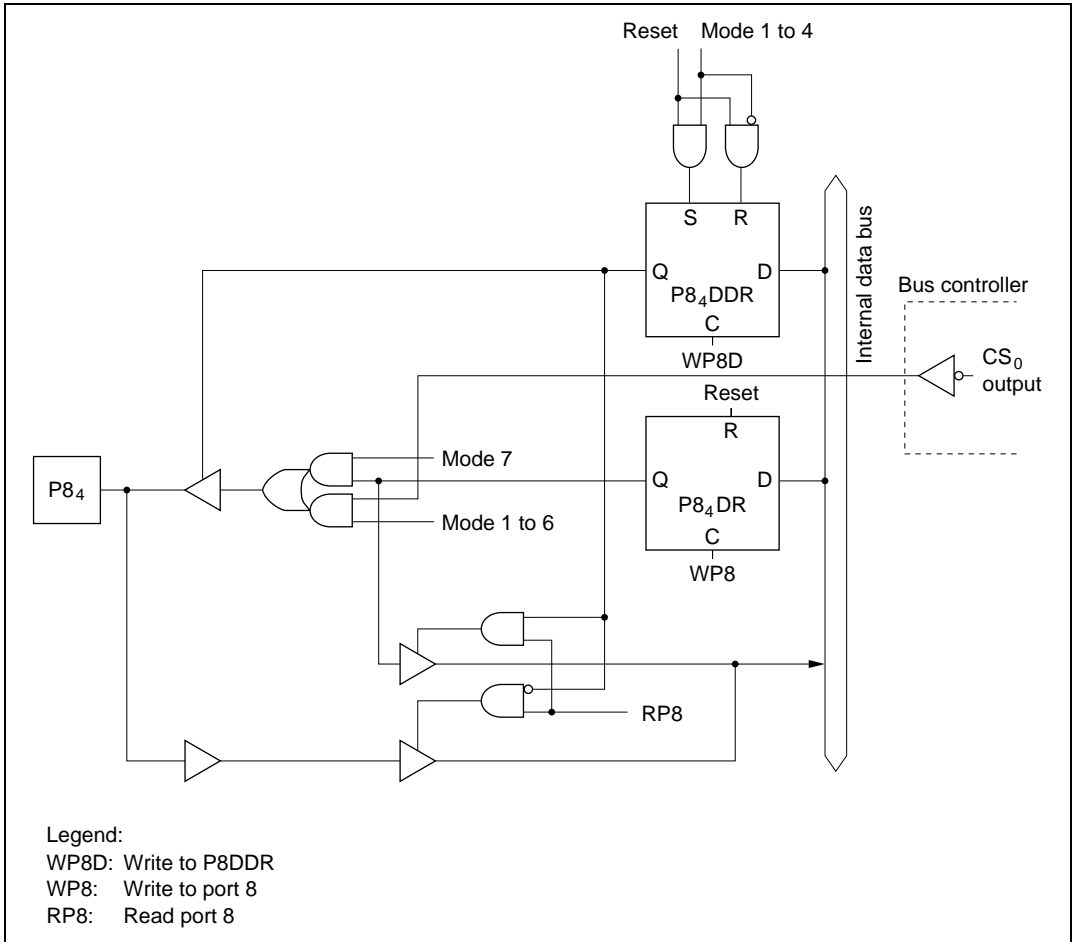

Figure C.8 (c) Port 8 Block Diagram (Pin P8₄)

C.9 Port 9 Block Diagrams

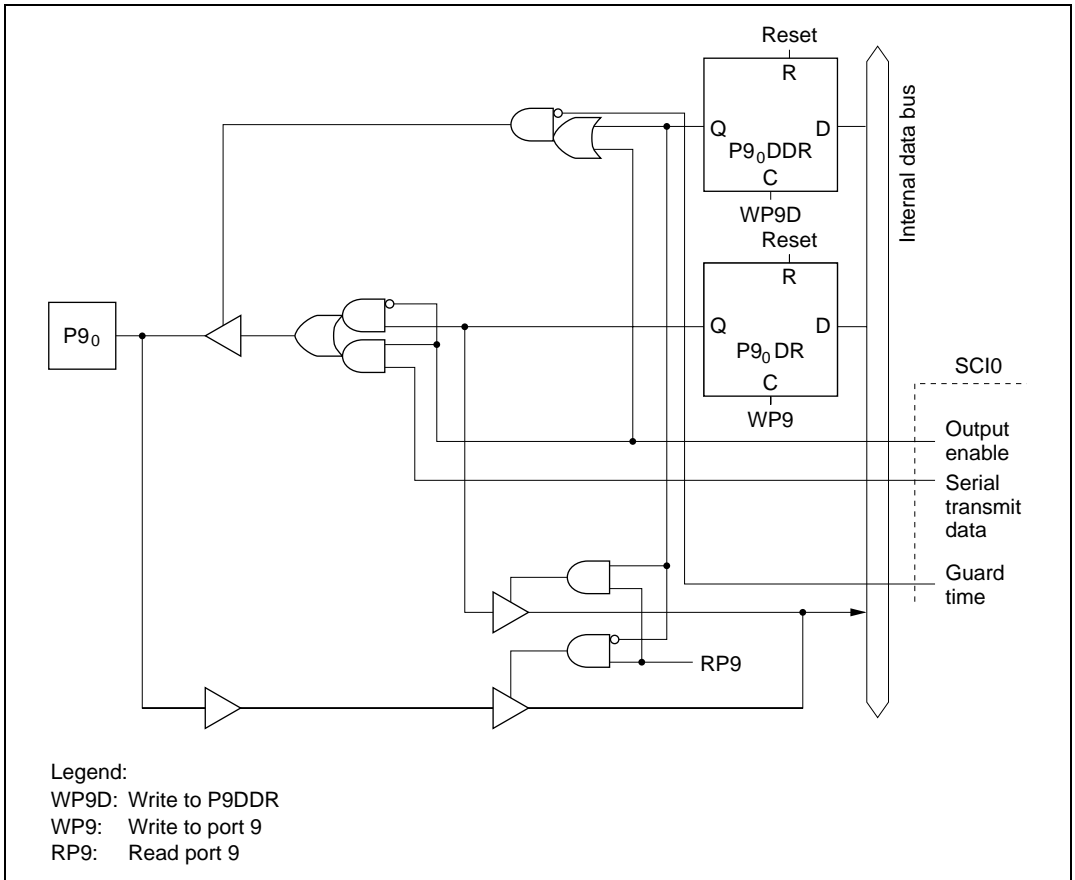

Figure C.9 (a) Port 9 Block Diagram (Pin P9₀)

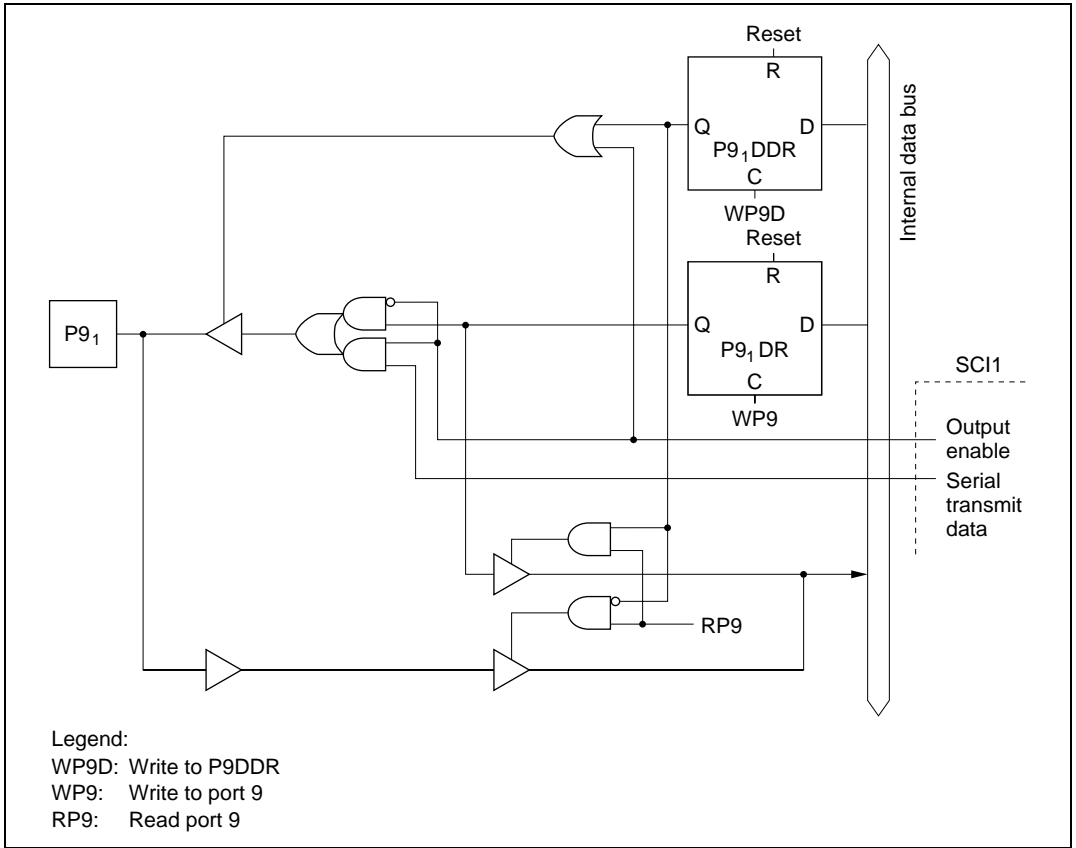
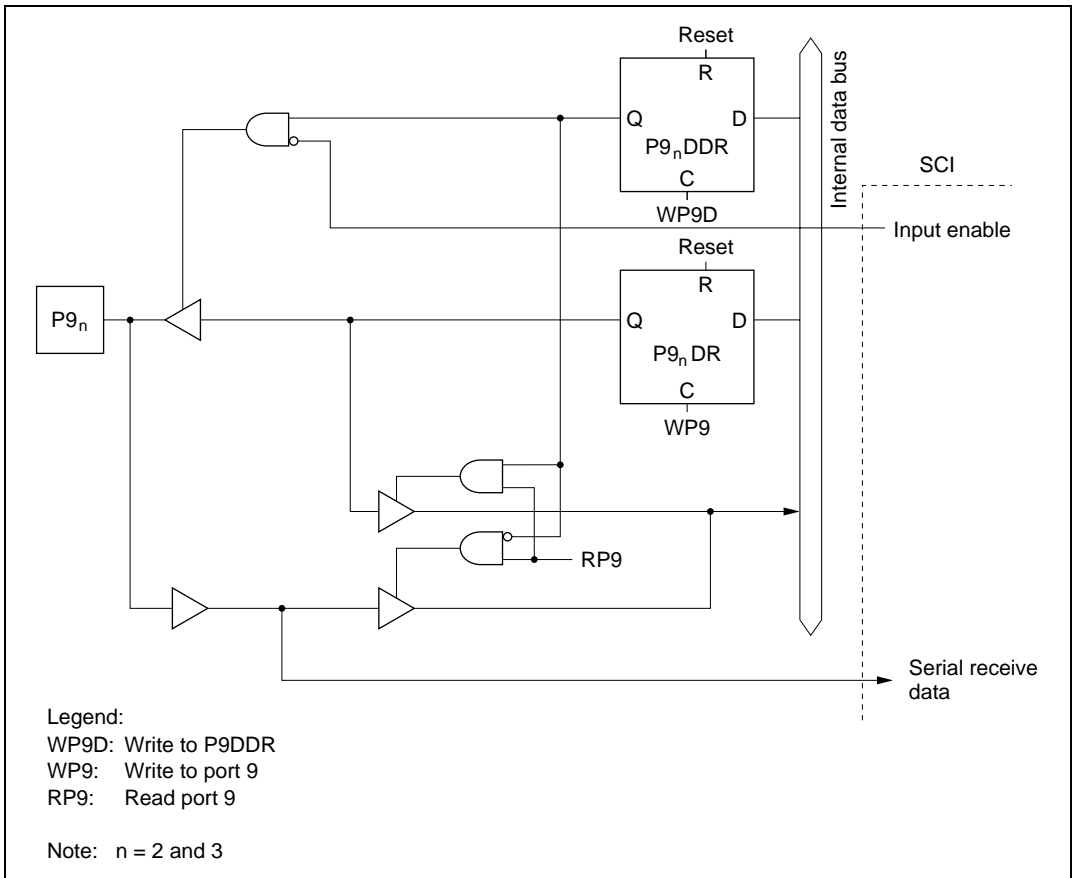

Figure C.9 (b) Port 9 Block Diagram (Pin P9₁)

Figure C.9 (c) Port 9 Block Diagram (Pins $P9_2$ and $P9_3$)

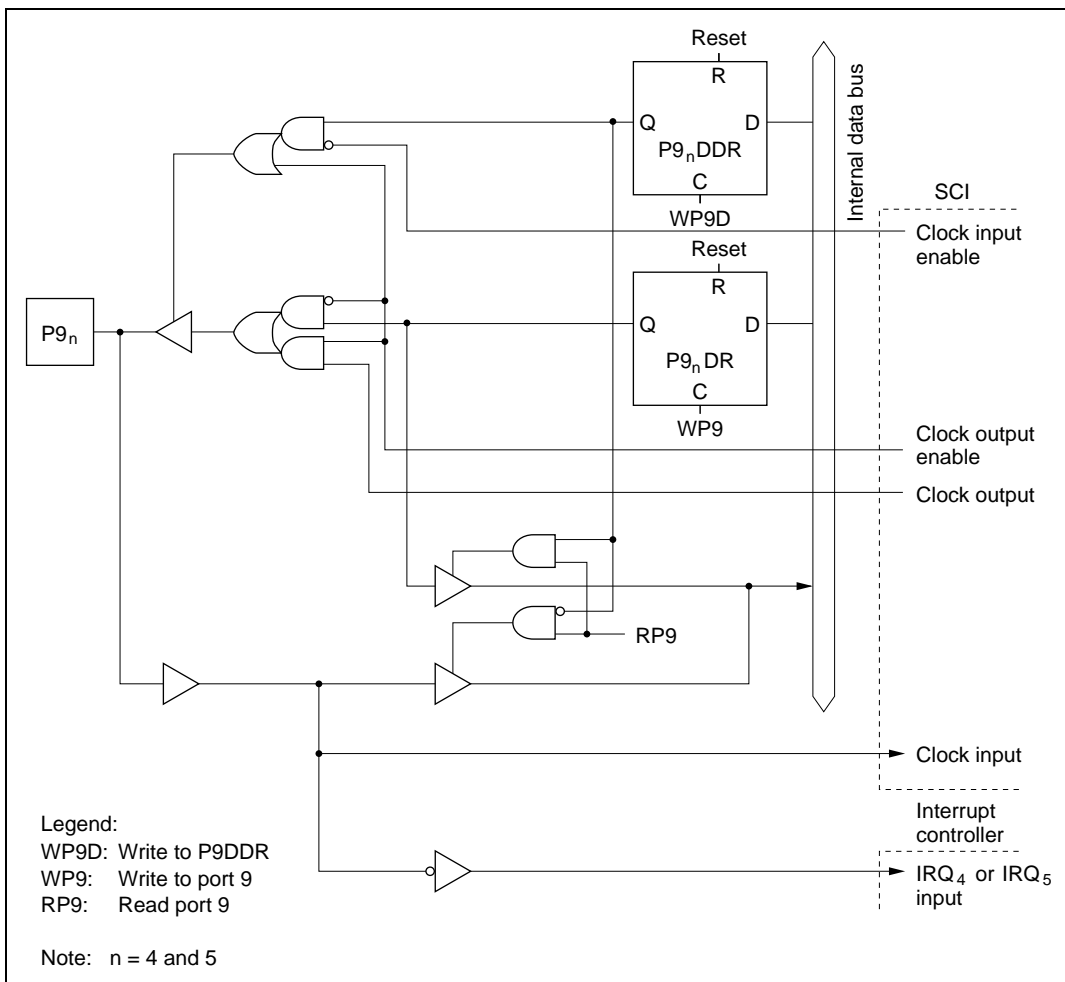

Figure C.9 (d) Port 9 Block Diagram (Pins P9₄ and P9₅)

C.10 Port A Block Diagrams

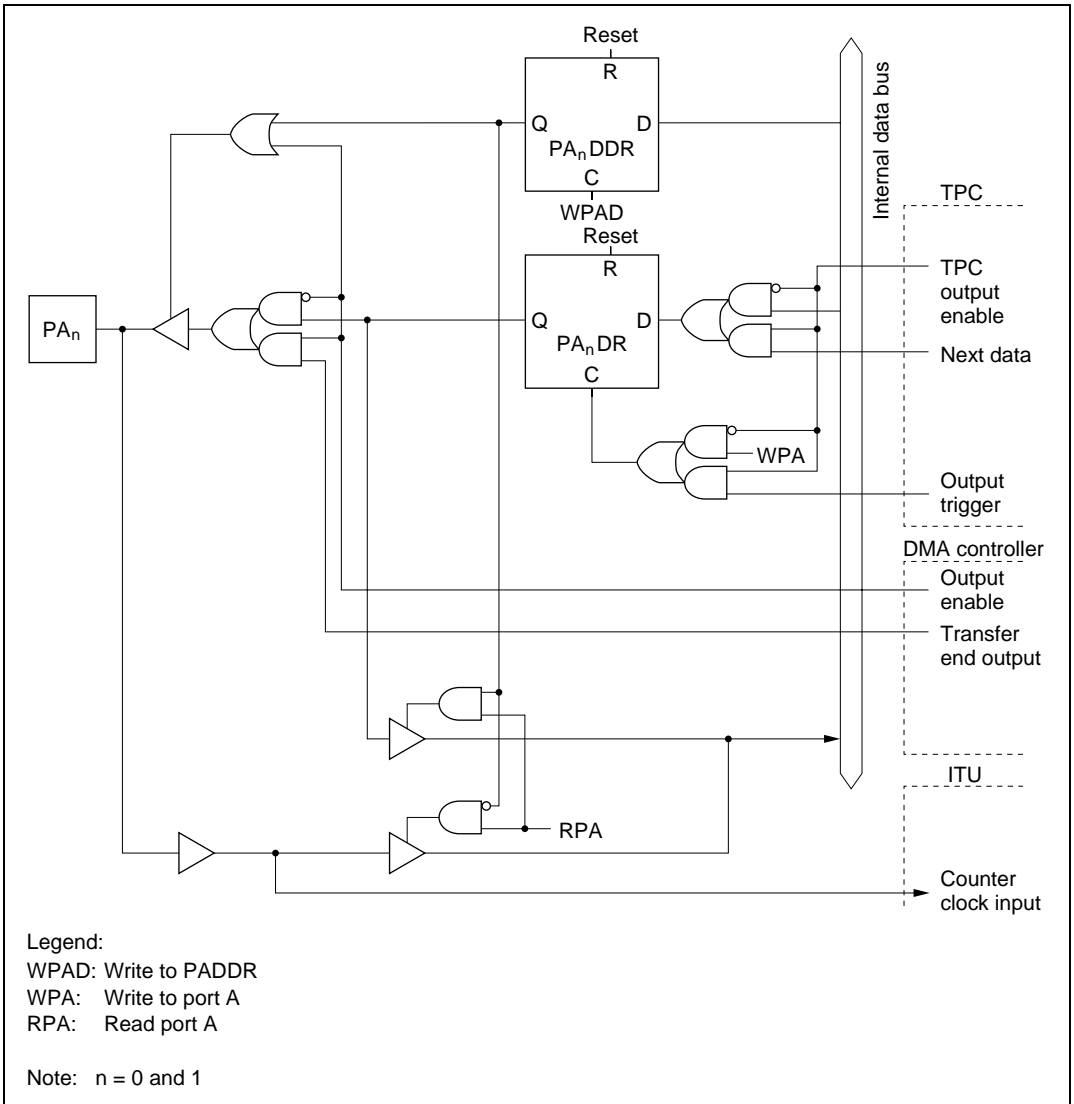
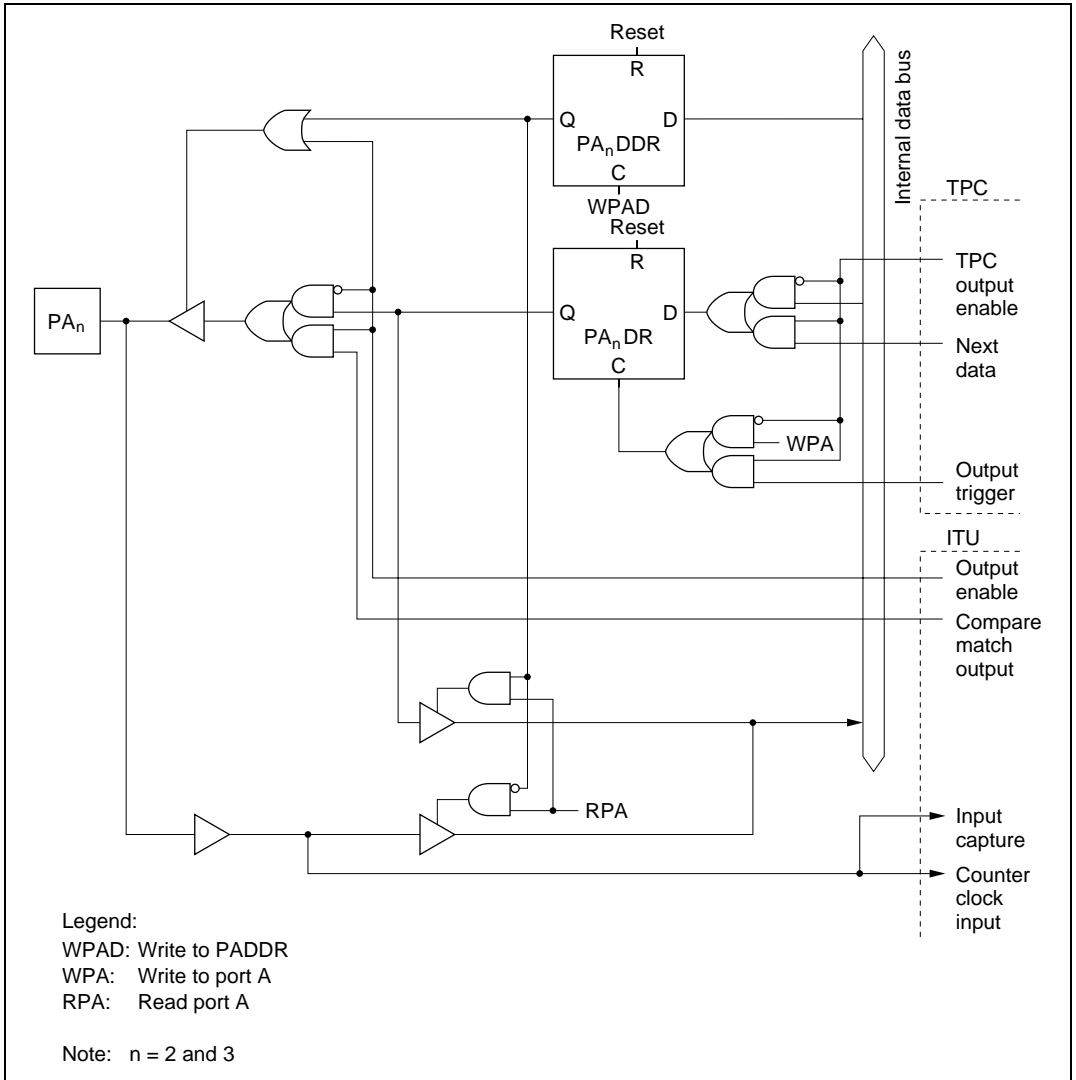

Figure C.10 (a) Port A Block Diagram (Pins PA₀ and PA₁)

Figure C.10 (b) Port A Block Diagram (Pins PA₂ and PA₃)

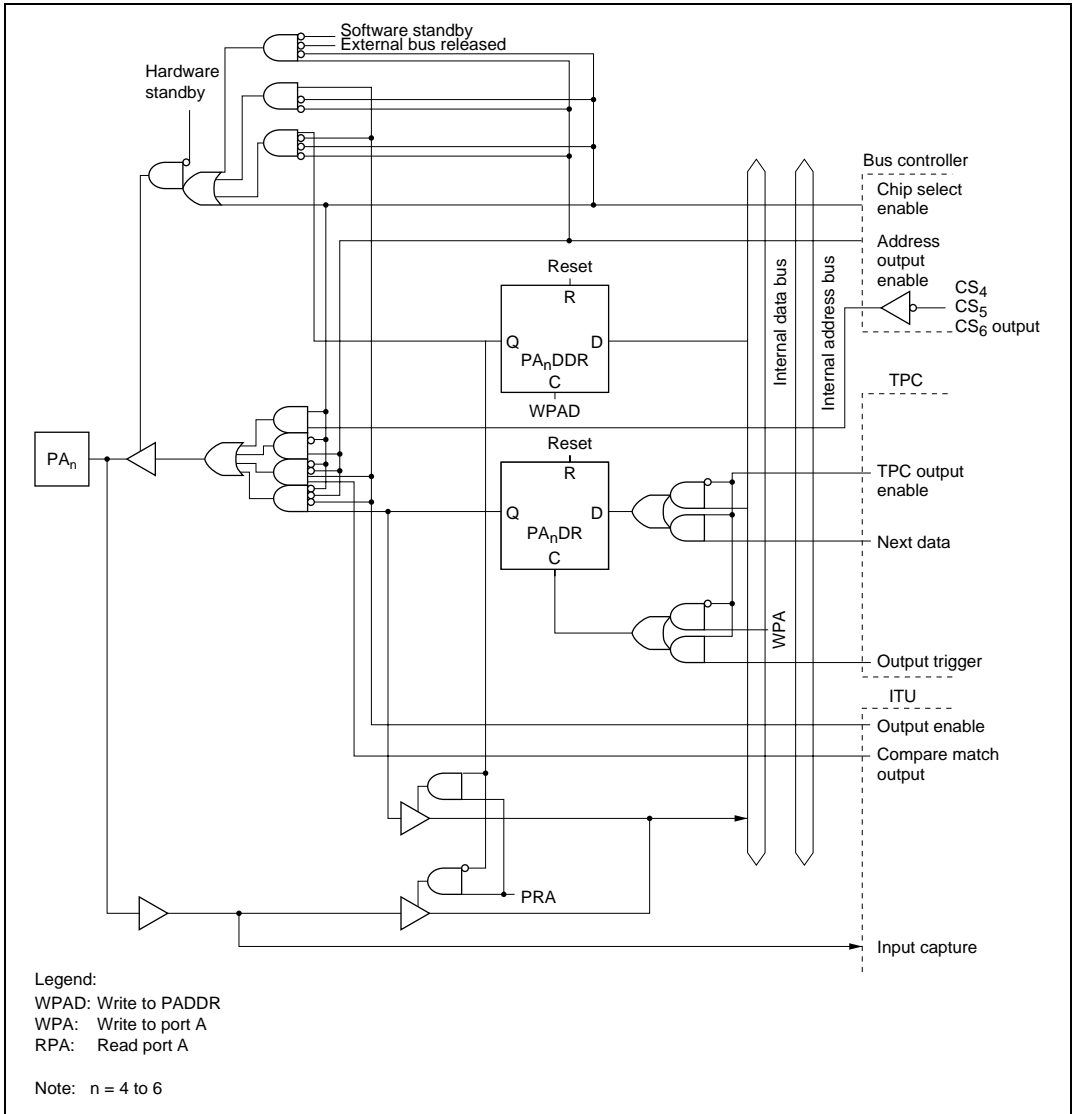

Figure C.10 (c) Port A Block Diagram (Pins PA_4 to PA_6)

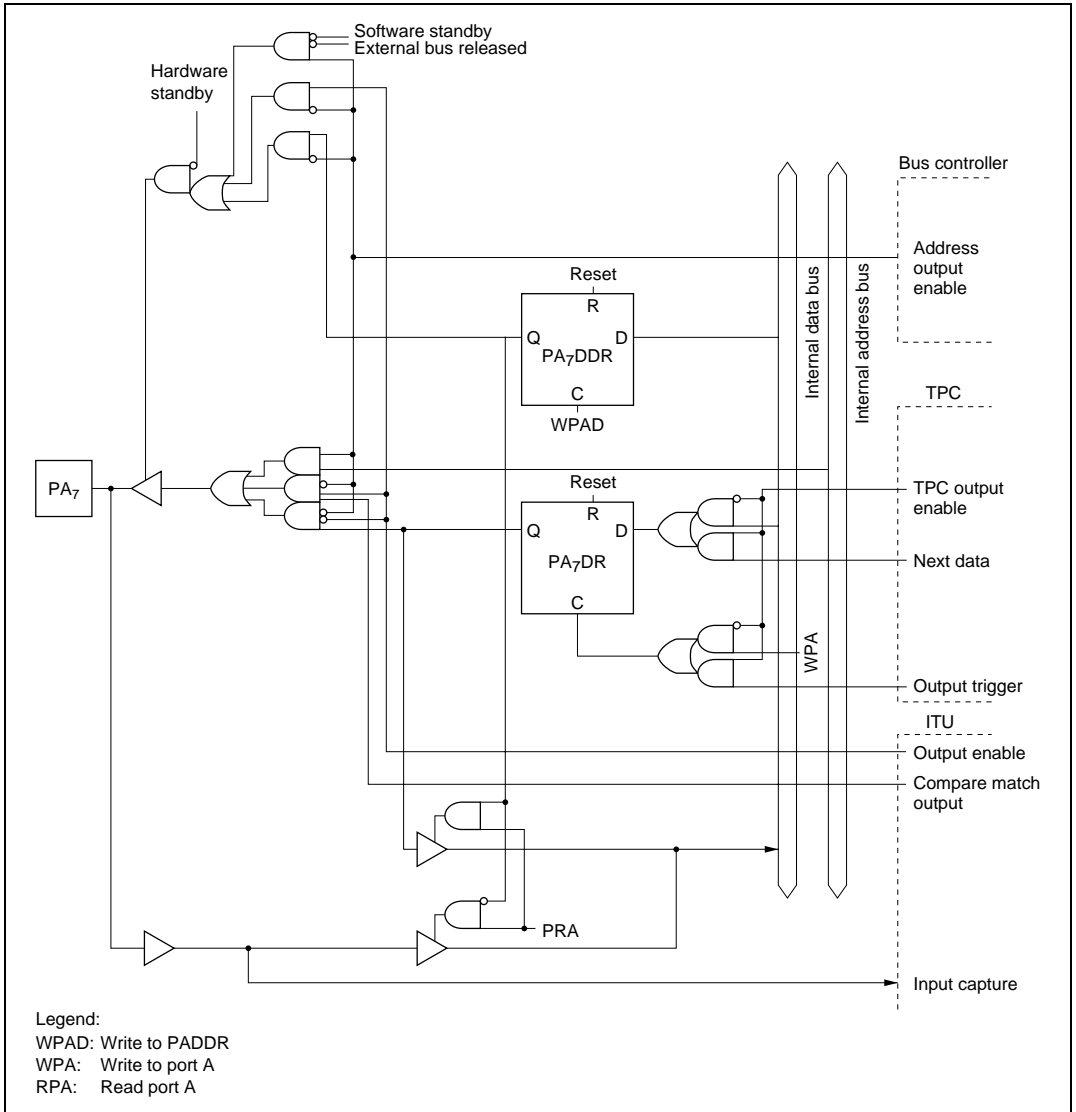

Figure C.10 (d) Port A Block Diagram (Pin PA₇)

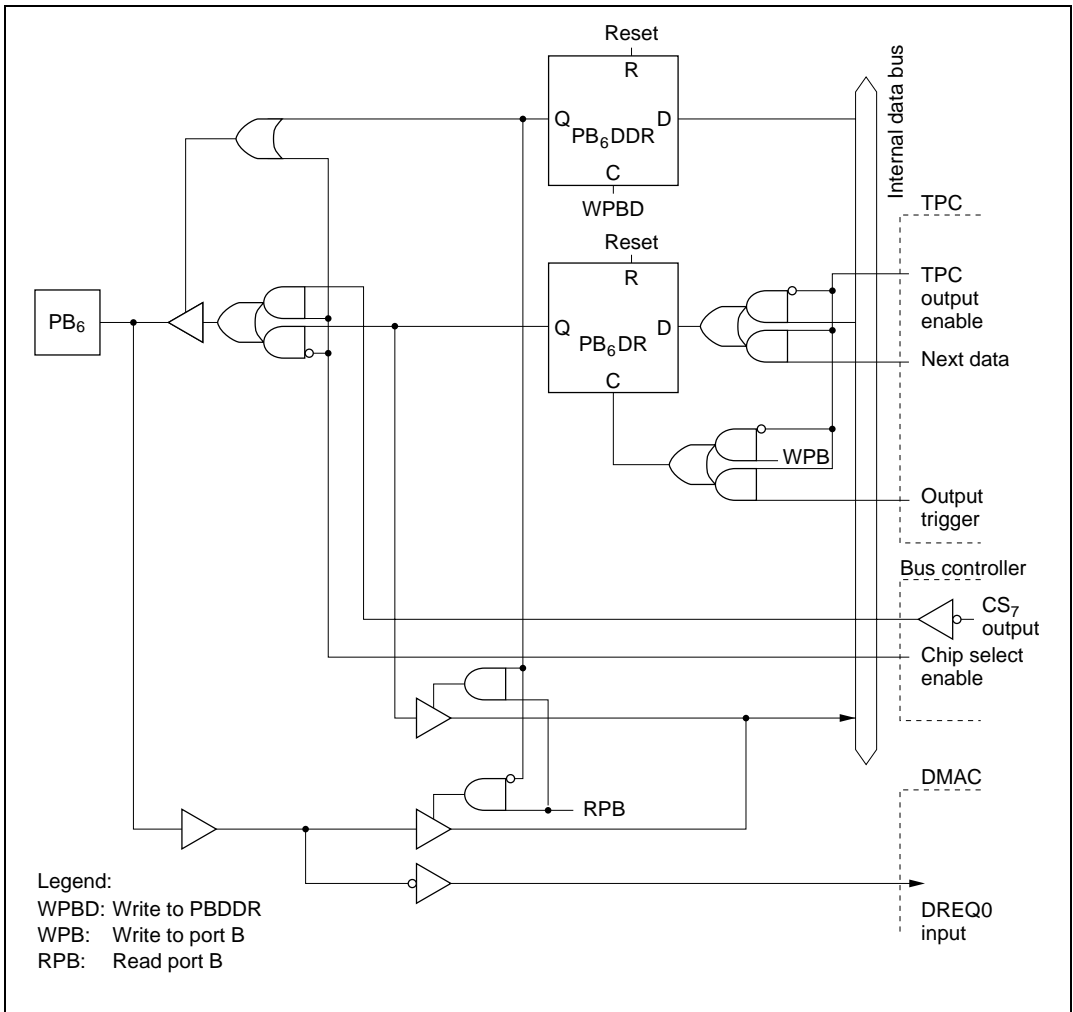
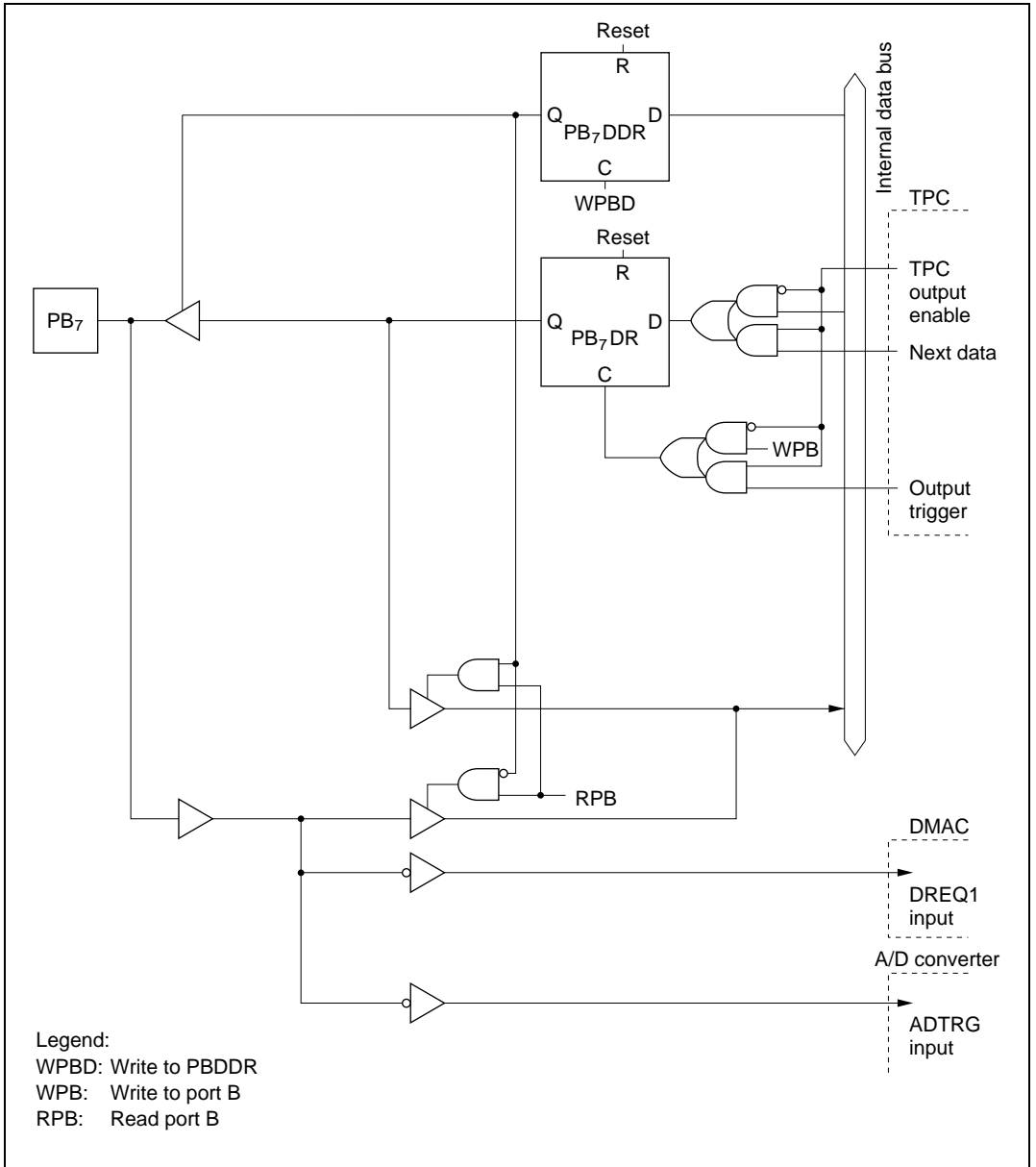

Figure C.11 (c) Port B Block Diagram (Pin PB₆)

Figure C.11 (d) Port B Block Diagram (Pin PB₇)

Appendix D Pin States

D.1 Port States in Each Mode

Table D.1 Port States

Pin Name	Mode	Reset	Hardware Standby Mode	Software Standby Mode	Bus-Released Mode	Program Execution, Sleep Mode	
ϕ	—	Clock output	T	H	Clock output	Clock output	
$\overline{\text{RESO}}^{*2}$	—	T^{*2}	T	T	T	$\overline{\text{RESO}}$	
P1 ₇ to P1 ₀	1 to 4	L	T	T	T	A ₇ to A ₀	
	5, 6	T	T	keep	T	Input port (DDR = 0)	
				T	T	A ₇ to A ₀ (DDR = 1)	
7	T	T	keep	—	I/O port		
P2 ₇ to P2 ₀	1 to 4	L	T	T	T	A ₁₅ to A ₈	
	5, 6	T	T	keep	T	Input port (DDR = 0)	
				T	T	A ₁₅ to A ₈ (DDR = 1)	
7	T	T	keep	—	I/O port		
P3 ₇ to P3 ₀	1 to 6	T	T	T	T	D ₁₅ to D ₈	
	7	T	T	keep	—	I/O port	
P4 ₇ to P4 ₀	1 to 6	8-bit bus	T	T	keep	keep	I/O port
	7	T	T	keep	—	I/O port	
P5 ₃ to P5 ₀	1 to 4	L	T	T	T	A ₁₉ to A ₁₆	
	5, 6	T	T	keep	T	Input port (DDR = 0)	
				T	T	A ₁₉ to A ₁₆ (DDR = 1)	
7	T	T	keep	—	I/O port		

Pin Name	Mode	Reset	Hardware Standby Mode	Software Standby Mode	Bus-Released Mode	Program Execution, Sleep Mode
P6 ₀	1 to 6	T	T	keep	keep	I/O port WAIT
	7	T	T	keep	—	I/O port
P6 ₁	1 to 6	T	T	keep (BRLE = 0) T (BRLE = 1)	T	I/O port BREQ
	7	T	T	keep	—	I/O port
P6 ₂	1 to 6	T	T	keep (BRLE = 0) H (BRLE = 1)	L	I/O port (BRLE = 0) or BACK (BRLE = 1)
	7	T	T	keep	—	I/O port
P6 ₆ to P6 ₃	1 to 6	H ^{*3}	T	T	T	\overline{AS} , \overline{RD} , \overline{HWR} , \overline{LWR}
	7	T	T	keep	—	I/O port
P7 ₇ to P7 ₀	1 to 7	T	T	T	T ^{*1}	Input port
P8 ₀	1 to 6	T	T	keep (RFSHE = 0) \overline{RFSH} (RFSHE = 1)	keep (RFSHE = 0) H (RFSHE = 1)	I/O port (RFSHE = 0) or \overline{RFSH} (RFSHE = 1)
	7	T	T	keep	—	I/O port
P8 ₃ to P8 ₁	1 to 6	T	T	T (DDR = 0) H (DDR = 1)	keep (DDR = 0) H (DDR = 1)	Input port (DDR = 0) or \overline{CS}_3 to \overline{CS}_1 (DDR = 1)
	7	T	T	keep	—	I/O port
P8 ₄	1 to 6	L	T	T (DDR = 0) L (DDR = 1)	keep (DDR = 0) H (DDR = 1)	Input port (DDR = 0) or \overline{CS}_0 (DDR = 1)
	7	T	T	keep	—	I/O port

Pin Name	Mode	Reset	Hardware Standby Mode	Software Standby Mode	Bus-Released Mode	Program Execution, Sleep Mode
P9 ₅ to P9 ₀	1 to 7	T	T	keep	keep ^{*1}	I/O port
PA ₃ to PA ₀	1 to 7	T	T	keep	keep ^{*1}	I/O port
PA ₆ to PA ₄	3, 4, 6	T ^{*4}	T	H (\overline{CS} output)	H (\overline{CS} output)	\overline{CS}_5 to \overline{CS}_4 (\overline{CS} output)
				T (address output) keep (otherwise)	T (address output) keep (otherwise)	A ₂₃ to A ₂₁ (address output) I/O port (otherwise)
PA ₇	1, 2, 5, 7	T ^{*4}	T	keep	keep ^{*1}	I/O port
	3, 4, 6	L ^{*4}	T	T	T	A ₂₀
PB ₇ , PB ₅ to PB ₀	1, 2, 5, 7	T ^{*4}	T	keep	keep ^{*1}	I/O port
	1 to 7	T	T	keep	keep ^{*1}	I/O port
PB ₆	3, 4, 6	T	T	H (\overline{CS} output)	H (\overline{CS} output)	\overline{CS}_7 (\overline{CS} output)
				keep (otherwise)	keep (otherwise)	I/O port (otherwise)
	1, 2, 5, 7	T	T	keep	keep ^{*1}	I/O port

Legend:

H: High

L: Low

T: High-impedance state

keep: Input pins are in the high-impedance state; output pins maintain their previous state.

DDR: Data direction register bit

Notes: 1. The bus cannot be released in mode 7.

2. Output is low only for reset by WDT overflow.

This \overline{RESO} output function is only for the mask ROM, ZTAT, and flash memory (dual power supply).

3. During direct power supply, oscillation damping time is "H" or "T".

4. During direct power supply, oscillation damping time differs between "H", "L" and "T".

D.2 Pin States at Reset

Reset in T1 State

Figure D.1 is a timing diagram for the case in which $\overline{\text{RES}}$ goes low during the T1 state of an external memory access cycle. As soon as $\overline{\text{RES}}$ goes low, all ports are initialized to the input state. $\overline{\text{AS}}$, $\overline{\text{RD}}$, $\overline{\text{HWR}}$, and $\overline{\text{LWR}}$ go high, and the data bus goes to the high-impedance state. The address bus is initialized to the low output level 0.5 state after the low level of $\overline{\text{RES}}$ is sampled. Sampling of $\overline{\text{RES}}$ takes place at the fall of the system clock (ϕ).

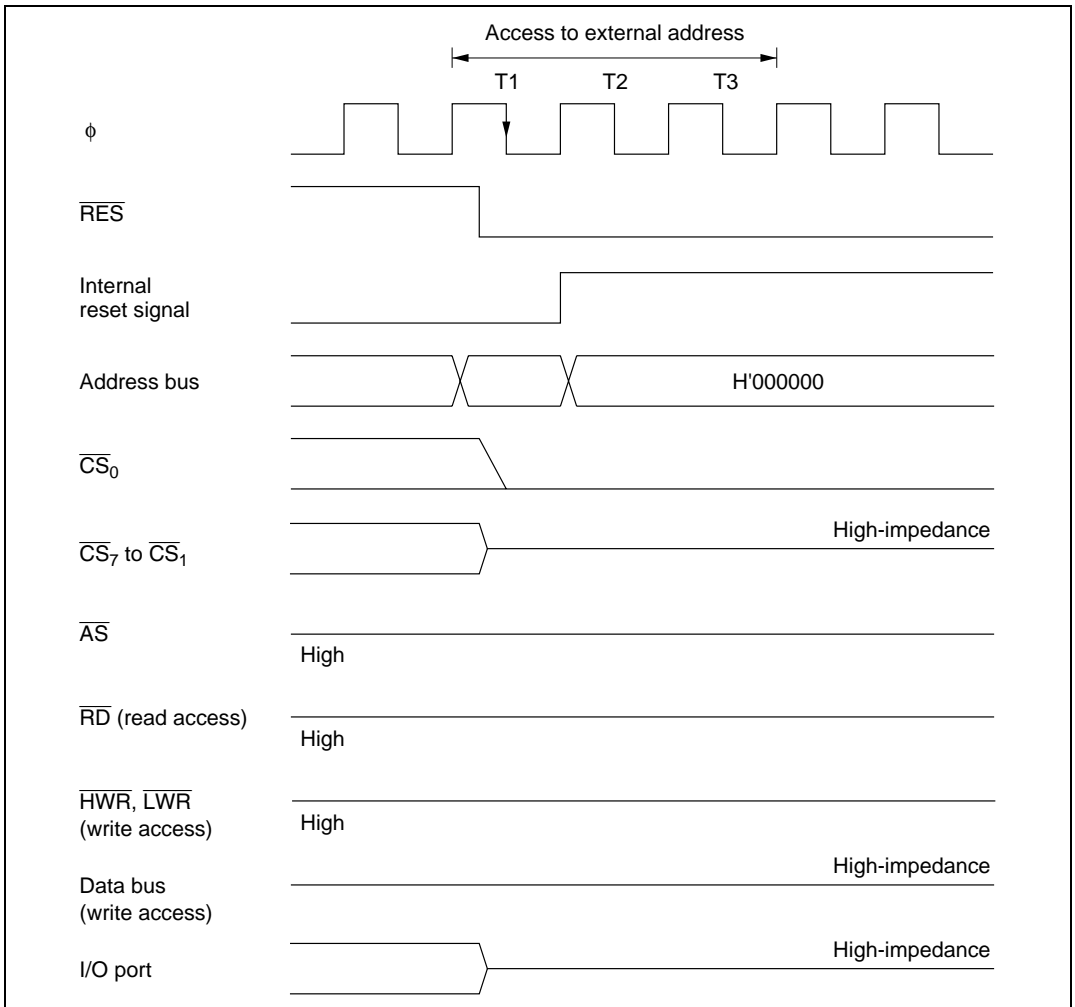

Figure D.1 Reset during Memory Access (Reset during T1 State)

Reset in T2 State

Figure D.2 is a timing diagram for the case in which $\overline{\text{RES}}$ goes low during the T2 state of an external memory access cycle. As soon as $\overline{\text{RES}}$ goes low, all ports are initialized to the input state. $\overline{\text{AS}}$, $\overline{\text{RD}}$, $\overline{\text{HWR}}$, and $\overline{\text{LWR}}$ go high, and the data bus goes to the high-impedance state. The address bus is initialized to the low output level 0.5 state after the low level of $\overline{\text{RES}}$ is sampled. The same timing applies when a reset occurs during a wait state (T_w).

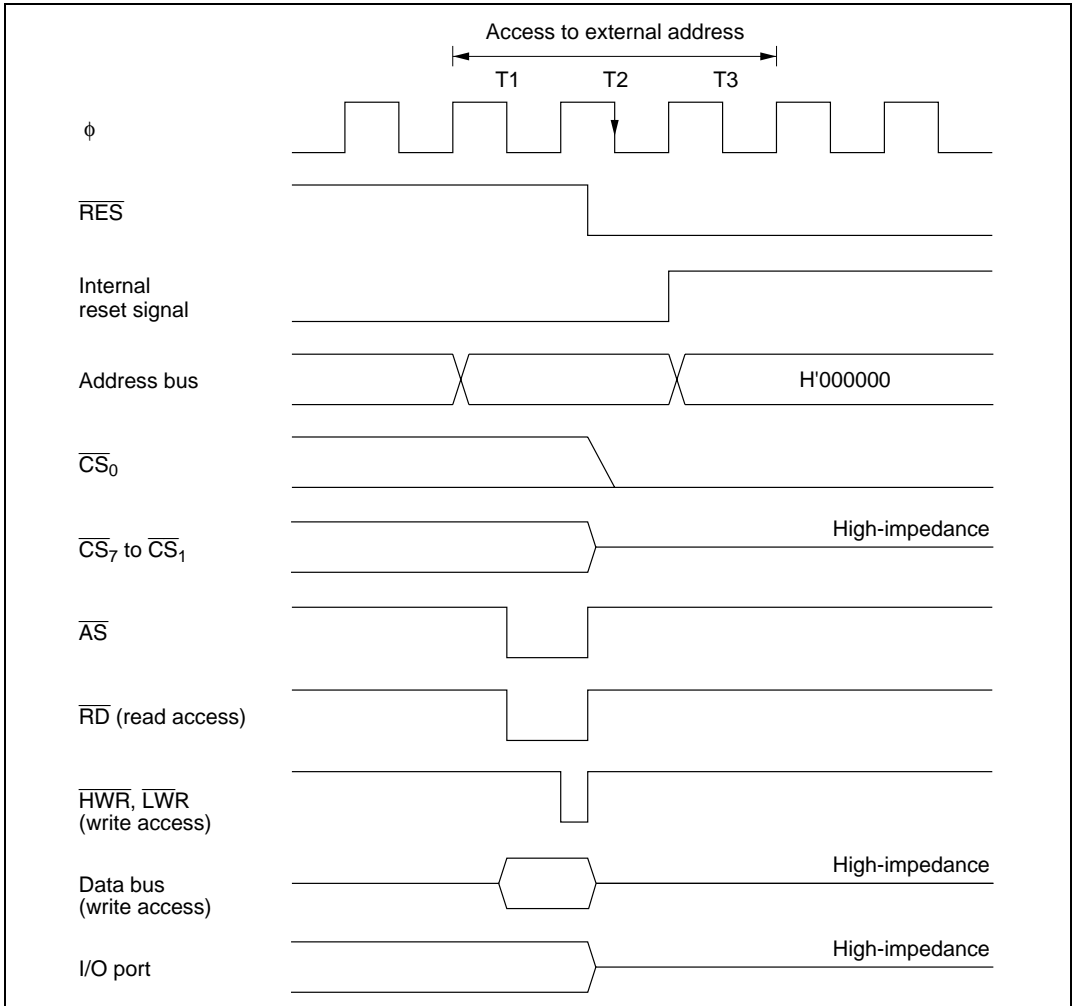

Figure D.2 Reset during Memory Access (Reset during T2 State)

Reset in T3 State

Figure D.3 is a timing diagram for the case in which $\overline{\text{RES}}$ goes low during the T3 state of an external memory access cycle. As soon as $\overline{\text{RES}}$ goes low, all ports are initialized to the input state. $\overline{\text{AS}}$, $\overline{\text{RD}}$, $\overline{\text{HWR}}$, and $\overline{\text{LWR}}$ go high, and the data bus goes to the high-impedance state. The address bus outputs are held during the T3 state. The same timing applies when a reset occurs in the T2 state of an access cycle to a two-state-access area.

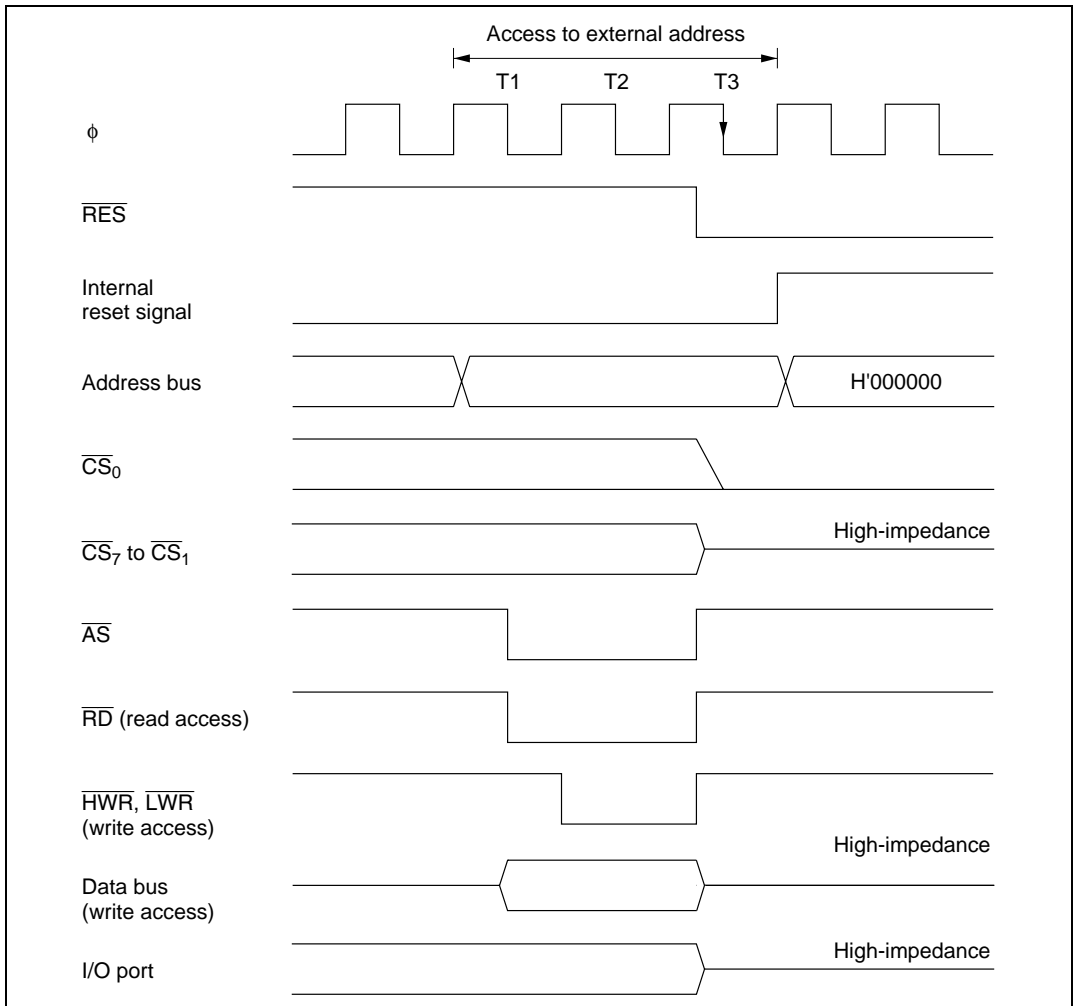
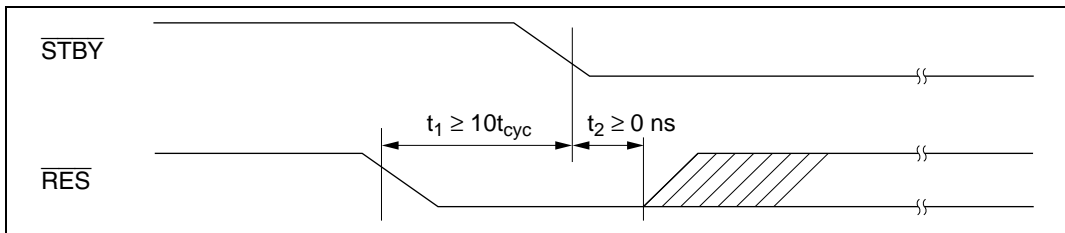

Figure D.3 Reset during Memory Access (Reset during T3 State)

Appendix E Timing of Transition to and Recovery from Hardware Standby Mode

Timing of Transition to Hardware Standby Mode

- (1) To retain RAM contents with the RAME bit set to 1 in SYSCR, drive the $\overline{\text{RES}}$ signal low 10 system clock cycles before the $\overline{\text{STBY}}$ signal goes low, as shown below. $\overline{\text{RES}}$ must remain low until $\overline{\text{STBY}}$ goes low (minimum delay from $\overline{\text{STBY}}$ low to $\overline{\text{RES}}$ high: 0 ns).



- (2) To retain RAM contents with the RAME bit cleared to 0 in SYSCR, or when RAM contents do not need to be retained, $\overline{\text{RES}}$ does not have to be driven low as in (1).

Timing of Recovery from Hardware Standby Mode

Drive the $\overline{\text{RES}}$ signal low approximately 100 ns before $\overline{\text{STBY}}$ goes high.

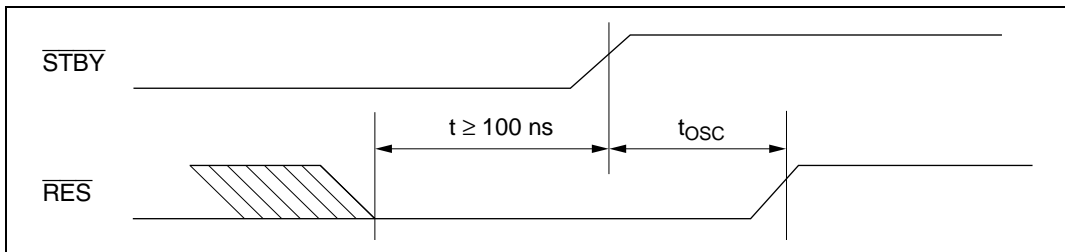

Appendix F Product Code Lineup

Table F.1 H8/3048 Group Product Code Lineup

Classification of Products			Product Code	Mark Code	Package (Package Code)
Product Type	Type of ROM	Power Supply Specifications			
H8/3048B	Mask ROM version	5 V version	HD6433048BTE		100-pin TQFP (TFP-100B)
			HD6433048BF		100-pin QFP (FP-100B)
		3 V version	HD6433048BVTE		100-pin TQFP (TFP-100B)
			HD6433048BVF		100-pin QFP (FP-100B)
H8/3048 F-ONE	Flash memory version (single power supply)	5 V version	HD64F3048BTE	64F3048TE	100-pin TQFP (TFP-100B)
			HD64F3048BF	64F3048F	100-pin QFP (FP-100B)
		3 V version	HD64F3048BVTE	64F3048VTE	100-pin TQFP (TFP-100B)
			HD64F3048BVF	64F3048VF	100-pin QFP (FP-100B)
H8/3048F	Flash memory version (dual power supply)	5 V version	HD64F3048TF	HD64F3048TF	100-pin TQFP (TFP-100B)
			HD64F3048F	HD64F3048F	100-pin QFP (FP-100B)
		3 V version	HD64F3048VTF	HD64F3048VTF	100-pin TQFP (TFP-100B)
			HD64F3048VF	HD64F3048VF	100-pin QFP (FP-100B)
H8/3048 ZTAT	PROM version	5 V version	HD6473048TF	HD6473048TF	100-pin TQFP (TFP-100B)
			HD6473048F	HD6473048F	100-pin QFP (FP-100B)
		3 V version	HD6473048VTF	HD6473048VTF	100-pin TQFP (TFP-100B)
			HD6473048VF	HD6473048VF	100-pin QFP (FP-100B)
H8/3048	Mask ROM version	5 V version	HD6433048TF	HD6433048(***)TF	100-pin TQFP (TFP-100B)
			HD6433048F	HD6433048(***)F	100-pin QFP (FP-100B)
		3 V version	HD6433048VTF	HD6433048(***)VTF	100-pin TQFP (TFP-100B)
			HD6433048VF	HD6433048(***)VF	100-pin QFP (FP-100B)
H8/3047	Mask ROM version	5 V version	HD6433047TF	HD6433047(***)TF	100-pin TQFP (TFP-100B)
			HD6433047F	HD6433047(***)F	100-pin QFP (FP-100B)
		3 V version	HD6433047VTF	HD6433047(***)VTF	100-pin TQFP (TFP-100B)
			HD6433047VF	HD6433047(***)VF	100-pin QFP (FP-100B)

Classification of Products			Product Code	Mark Code	Package (Package Code)
Product Type	Type of ROM	Power Supply Specifications			
H8/3045	Mask ROM version	5 V version	HD6433045TF	HD6433045(***)TF	100-pin TQFP (TFP-100B)
			HD6433045F	HD6433045(***)F	100-pin QFP (FP-100B)
		3 V version	HD6433045VTF	HD6433045(***)VTF	100-pin TQFP (TFP-100B)
			HD6433045VF	HD6433045(***)VF	100-pin QFP (FP-100B)
H8/3044	Mask ROM version	5 V version	HD6433044TF	HD6433044(***)TF	100-pin TQFP (TFP-100B)
			HD6433044F	HD6433044(***)F	100-pin QFP (FP-100B)
		3 V version	HD6433044VTF	HD6433044(***)VTF	100-pin TQFP (TFP-100B)
			HD6433044VF	HD6433044(***)VF	100-pin QFP (FP-100B)

Note: (***) in mask ROM versions is the ROM code.

Appendix G Package Dimensions

The package dimension that is shown in the Renesas Semiconductor Package Data Book has priority.

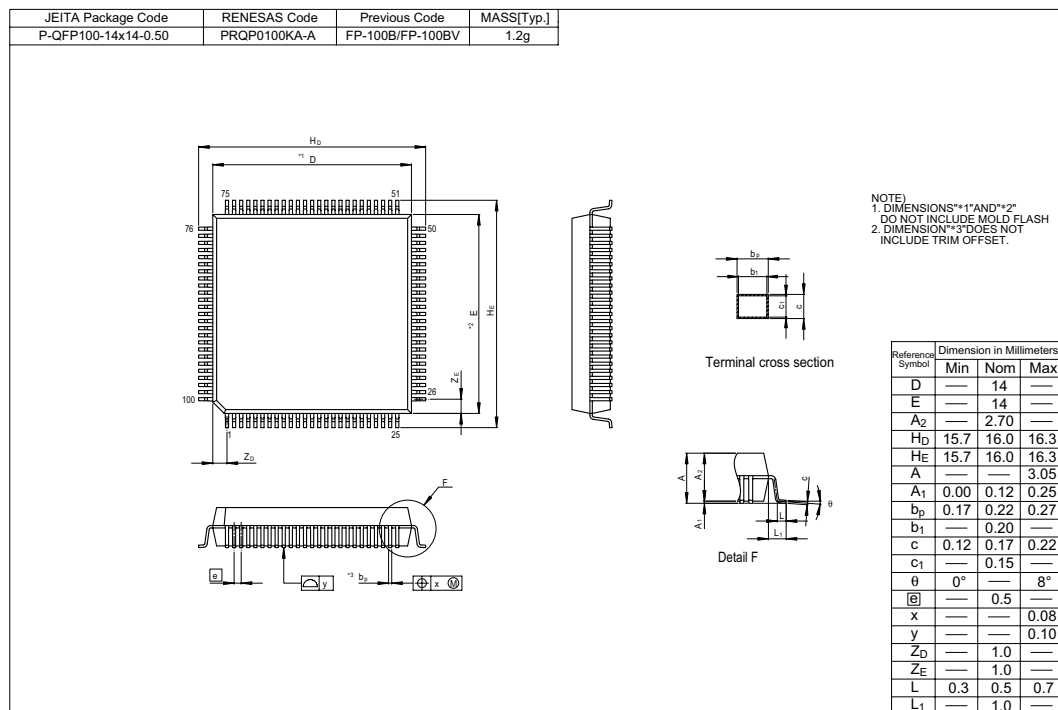

Figure G.1 Package Dimensions (FP-100B)

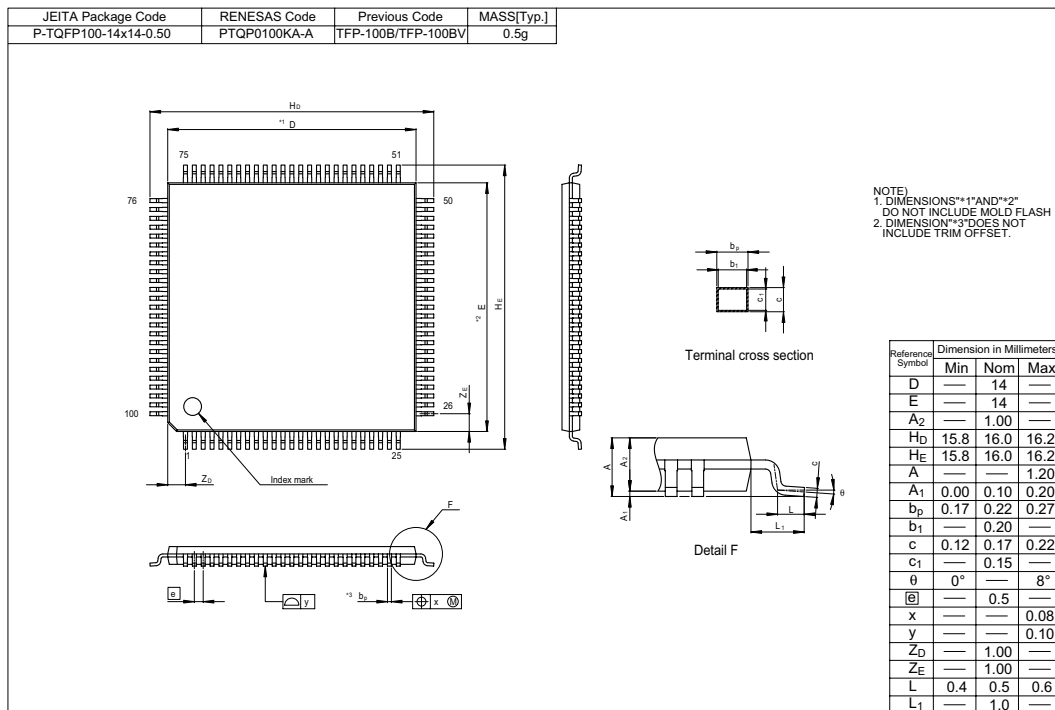

Figure G.2 Package Dimensions (TFP-100B)

**Renesas 8-Bit Single-Chip Microcomputer
Hardware Manual
H8/3048B Group**

Publication Date: 1st Edition, August 2002
Rev.3.00, September 27, 2006
Published by: Sales Strategic Planning Div.
Renesas Technology Corp.
Edited by: Customer Support Department
Global Strategic Communication Div.
Renesas Solutions Corp.

Renesas Technology Corp. Sales Strategic Planning Div. Nippon Bldg., 2-6-2, Ohte-machi, Chiyoda-ku, Tokyo 100-0004, Japan



RENESAS SALES OFFICES

<http://www.renesas.com>

Refer to "<http://www.renesas.com/en/network>" for the latest and detailed information.

Renesas Technology America, Inc.

450 Holger Way, San Jose, CA 95134-1368, U.S.A
Tel: <1> (408) 382-7500, Fax: <1> (408) 382-7501

Renesas Technology Europe Limited

Dukes Meadow, Millboard Road, Bourne End, Buckinghamshire, SL8 5FH, U.K.
Tel: <44> (1628) 585-100, Fax: <44> (1628) 585-900

Renesas Technology (Shanghai) Co., Ltd.

Unit 204, 205, AZIA Center, No.1233 Lujiazui Ring Rd, Pudong District, Shanghai, China 200120
Tel: <86> (21) 5877-1818, Fax: <86> (21) 6887-7898

Renesas Technology Hong Kong Ltd.

7th Floor, North Tower, World Finance Centre, Harbour City, 1 Canton Road, Tsimshatsui, Kowloon, Hong Kong
Tel: <852> 2265-6688, Fax: <852> 2730-6071

Renesas Technology Taiwan Co., Ltd.

10th Floor, No.99, Fushing North Road, Taipei, Taiwan
Tel: <886> (2) 2715-2888, Fax: <886> (2) 2713-2999

Renesas Technology Singapore Pte. Ltd.

1 Harbour Front Avenue, #06-10, Keppel Bay Tower, Singapore 098632
Tel: <65> 6213-0200, Fax: <65> 6278-8001

Renesas Technology Korea Co., Ltd.

Kukje Center Bldg. 18th Fl., 191, 2-ka, Hangang-ro, Yongsan-ku, Seoul 140-702, Korea
Tel: <82> (2) 796-3115, Fax: <82> (2) 796-2145

Renesas Technology Malaysia Sdn. Bhd

Unit 906, Block B, Menara Amcorp, Amcorp Trade Centre, No.18, Jalan Persiaran Barat, 46050 Petaling Jaya, Selangor Darul Ehsan, Malaysia
Tel: <603> 7955-9390, Fax: <603> 7955-9510

H8/3048B Group Hardware Manual



Renesas Electronics Corporation

1753, Shimonumabe, Nakahara-ku, Kawasaki-shi, Kanagawa 211-8668 Japan

REJ09B0325-0300