

DESCRIPTION: MALE - WIRE WRAP / MACHINED - PREMIUM

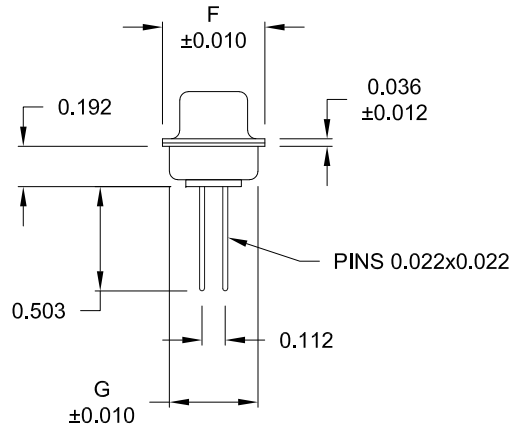
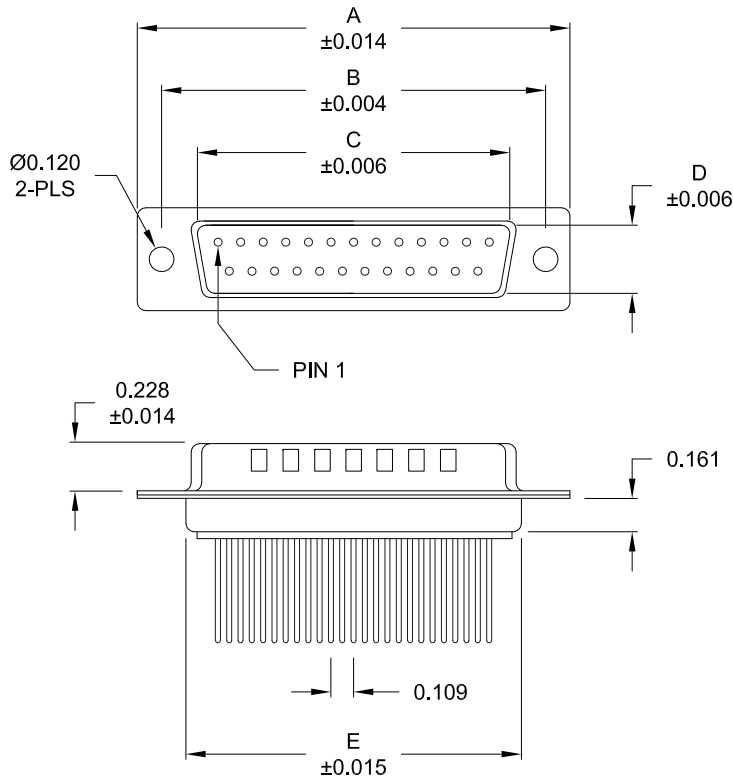

| No. OF PINS | DIMENSIONS | | | | | | |
|-------------|------------|-------|-------|-------|-------|-------|-------|
| | A | B | C | D | E | F | G |
| 9 | 1.213 | 0.984 | 0.669 | 0.331 | 0.760 | 0.496 | 0.429 |
| | 30.80 | 24.99 | 17.00 | 8.40 | 19.30 | 12.60 | 10.90 |
| 15 | 1.541 | 1.312 | 0.996 | 0.331 | 1.083 | 0.496 | 0.429 |
| | 39.15 | 33.32 | 25.30 | 8.40 | 27.51 | 12.60 | 10.90 |
| 25 | 2.088 | 1.852 | 1.535 | 0.331 | 1.630 | 0.496 | 0.429 |
| | 53.04 | 47.04 | 39.00 | 8.40 | 41.40 | 12.60 | 10.90 |
| 37 | 2.729 | 2.500 | 2.181 | 0.331 | 2.276 | 0.496 | 0.429 |
| | 69.32 | 63.50 | 55.40 | 8.40 | 57.81 | 12.60 | 10.90 |
| 50 | 2.635 | 2.406 | 2.079 | 0.437 | 2.182 | 0.598 | 0.535 |
| | 66.93 | 61.11 | 52.80 | 11.10 | 55.42 | 15.20 | 13.60 |

172-YYY-142RYY1

- SERIES _____
- POSITIONS _____
- 009 _____
- 015 _____
- 025 _____
- 037 _____
- 050 _____
- GENDER _____
- 1 = MALE
- TERMINATION _____
- 4 = WIRE WRAP
- SHELL PLATING _____
- 2 = TIN (GROUND INDENTS)
- RoHS COMPLIANT _____
- HARDWARE OPTIONS _____
- 00 = NO HARDWARE
- 01 = .065" CLINCH NUT (BOARD SIDE)
- 02 = .250" CLINCH NUT (BOARD SIDE)
- 03 = .250" CLINCH NUT (MOUNTING SIDE)
- 05 = .237" 4-40 BOARD LOCK
- 91 = .237" 4-40 SPACER/ BOARD LOCK
- PLATING OPTIONS _____
- 1 = GOLD FLASH
- 2 = 30MICRO-INCH GOLD

MATERIAL:

SHELL: STEEL, TIN PLATED
 INSULATOR: UL 94V-O RATED, PA6T
 PROCESS TEMP.: 260°C
 CONTACT: BRASS

ELECTRICAL:

CURRENT RATING: 5 AMPS
 CONTACT RESISTANCE: 15 mOhms Max.
 INSULATION RESISTANCE: 1,000 MOhms Min.
 VOLTAGE: 500VAC FOR 1 MINUTE
 TEMPERATURE: -50° C TO 100° C

DO NOT SCALE FROM DRAWING



THESE DRAWINGS AND SPECIFICATIONS ARE THE PROPERTY OF NorComp AND SHALL NOT BE REPRODUCED, COPIED OR USED AS THE BASIS FOR THE MANUFACTURE OF SALE OF APPARATUS WITHOUT WRITTEN PERMISSION.

| | | | |
|-------------------------|--|----------------|--|
| DRAWN: PAM JENKINS | | DATE: 11-23-05 | |
| SCALE: NTS | | SHEET 1 OF 3 | |
| DWG NO. 172-YYY-142RYY1 | | REV 13 | |

NorComp

RoHS COMPLIANT

DESCRIPTION: PCB LAYOUT - STANDARD "D" - MALE & FEMALE

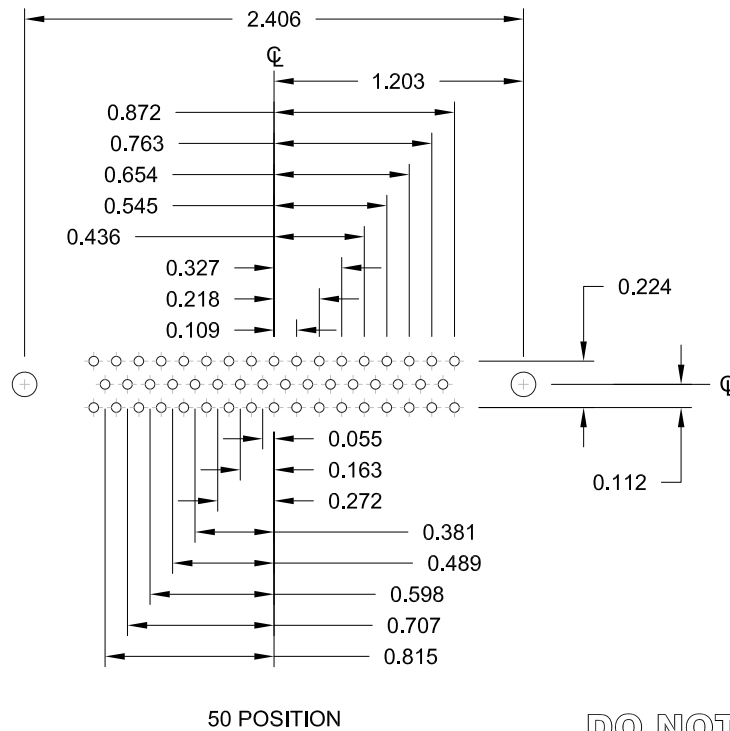
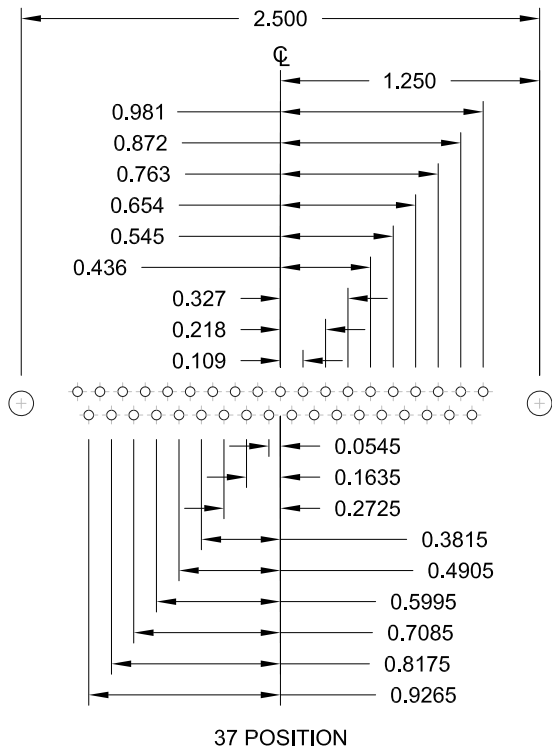
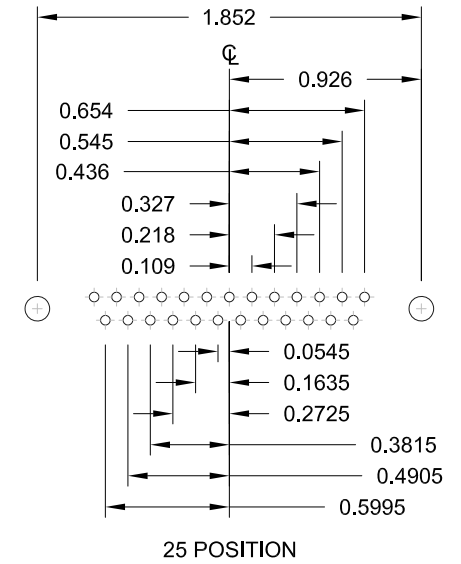
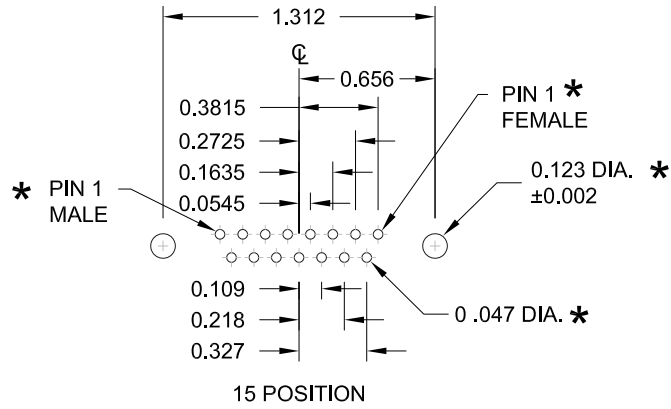
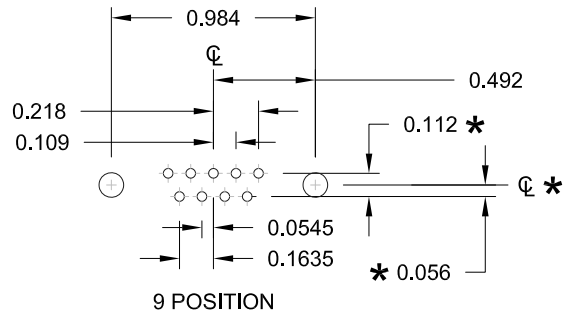

* TYP. ON ALL SIZES

DO NOT SCALE FROM DRAWING

| | | | | |
|--|---|--|------------------------------|--------------------------|
|  | THESE DRAWINGS AND SPECIFICATIONS ARE THE PROPERTY OF NorComp AND SHALL NOT BE REPRODUCED, COPIED OR USED AS THE BASIS FOR THE MANUFACTURE OF SALE OF APPARATUS WITHOUT WRITTEN PERMISSION. | | DRAWN: PAM JENKINS | DATE: 11-23-05 |
| | NorComp | | SCALE: NTS | SHEET OF 2 3 |
| DWG NO. 172-YYY-142RYY1 | | | | |

ALL CLINCH-NUTS ARE 4-40 INTERNAL THREADS

01X 0.065" (BOARD SIDE)

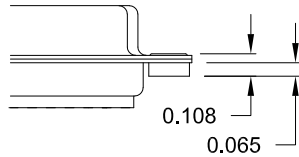

02X 0.250" (BOARD SIDE)

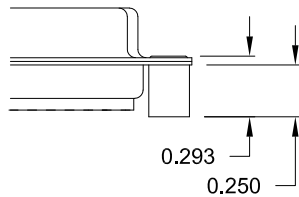

03X..... 0.250" (MATING SIDE)

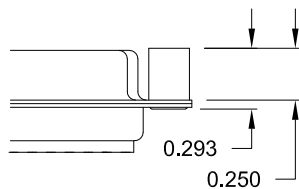

05X 0.237" (BOARD SIDE)

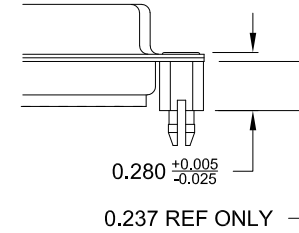

91X 0.237" (BOARD SIDE)

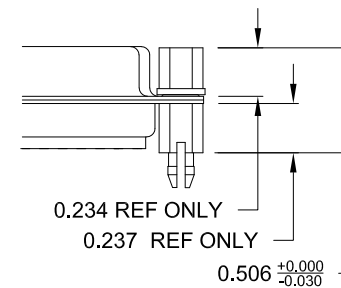

TOLERANCE:
ALL DIMENSIONS ARE ±0.010
UNLESS OTHERWISE
SPECIFIED

NOTE: 4-40 FEMALE SCREW LOCK IS REMOVABLE

DO NOT SCALE FROM DRAWING

RoHS COMPLIANT

| | | | | |
|--|---|--|------------------------------|--------------------------|
|  | THESE DRAWINGS AND SPECIFICATIONS ARE THE PROPERTY OF NorComp AND SHALL NOT BE REPRODUCED, COPIED OR USED AS THE BASIS FOR THE MANUFACTURE OF SALE OF APPARATUS WITHOUT WRITTEN PERMISSION. | | DRAWN: PAM JENKINS | DATE: 11-23-05 |
| | NorComp | | SCALE: NTS | SHEET OF 3 3 |
| DWG NO. 172-YYY-142RYY1 | | | | |