

3130 Thermal Overcurrent Circuit Breaker

Description

Single, two and three pole rocker switch/thermal trip free circuit breakers (S-type TO CBE to EN 60934) of compact design for snap-in panel mounting. Available either with protection on one/both/all poles or, in the case of the double pole version, protection on one pole only. Illumination is optional and there is a choice of rocker colours. Approved to CBE standard EN 60934 (IEC 60934).

Typical applications

Motors, protection of transformers (e.g. for illumination), solenoids, household and office machines, electrical tools, mobile homes, boats, construction vehicles, medical equipment to EN 60601.

Features and benefits

- Single pole, double pole or three-pole thermal circuit breaker/switch combination
- Voltage ratings AC 240 V; 3 AC 415 V; DC 50 V
- Current ratings: 0.1...20 A
- Rating UL1077/AC 277 V, Use Group EA for industrial applications
- Can be combined with X3120 Power Entry Module. Please refer to the respective section in this document.

Compliances

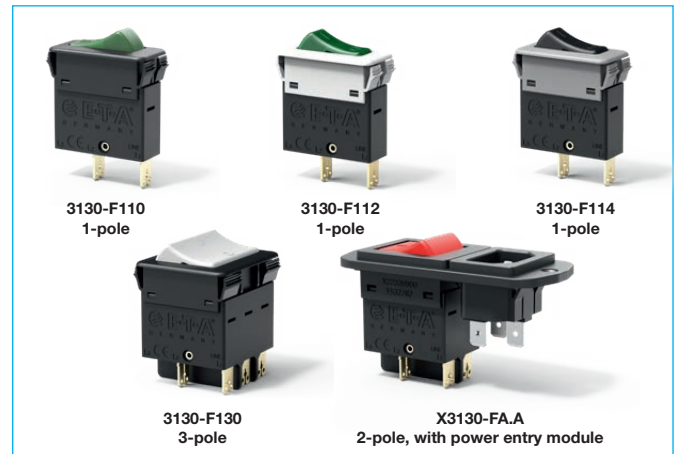



Your benefits

- Maximum equipment availability is ensured by overload protection perfectly matched with the loads (prevention of nuisance tripping) and quick resetability
- Reduced mounting and wiring time
- Less space requirement
- Less disposition and storage costs
- Enhanced overall reliability

Information online

The current data sheet is available on our website: www.e-t-a.de/d001

Approvals

Authority	Standard	Rated voltage	Current ratings	Approval logos	
VDE	IEC/EN 60934	AC 240 V AC 240 V 3 AC 415 V DC 50 V DC 28 V	0.1 A...20 A (1-pole) 0.1A...16 A (2-pole) 0.1A...16 A (3-pole) 0.1A...16 A (1-, 2-pole) 0.1 A...20 A (1-pole)		
CQC ⁽¹⁾	GB/T 17701	AC 240 V AC 240 V 3 AC 415 V DC 50 V	0.1 A...20 A (1-pole) 0.1A...16 A (2-pole) 0.1A...16 A (3-pole) 0.1A...16 A (1-, 2-pole)		
<small>(1) not for frame mounting 2/3/4/5</small>					
Authority	Standard	Rated voltage	Current ratings	UL-categories	Approval logos
				UG TC OL	
UL/CSA	UL 1077, CSA C22.2 No.235	AC 277 V AC 250 V AC 250 V DC 50 V	0.1...16 A ^(a) 0.1...16 A ^(b) 0.1...12 A ^(c) 0.1...16 A ^(d)	EA 1 1 B, D 1 ^(a) , 2 1 B, D 2 1 B, D 1 ^(a) , 2 1	

^(a) 1- and 2-pole, all poles protected

^(b) 1- and 2-pole

^(c) 3-pole

^(d) 1-, 2- and 3-pole

Technical data

For further details please see: www.e-t-a.de/ti_e

Voltage rating AC 240 V; 3 AC 415 V; DC 50 V
(UL: AC 250 V; 3 AC 250 V; DC 50 V)

Current ratings 0.1...20 A 1-pole
0.1...16 A 2- and 3-pole

Typical life 1-pole (IEC/EN 60934)

AC 240 V: 0.1...20 A 30,000 operations at $1 \times I_N$, inductive

DC 50 V: 0.1...4 A 30,000 operations at $1 \times I_N$, inductive

4.5...16 A 30,000 operations at $1 \times I_N$, resistive

DC 28 V: 0.1...20 A 30,000 operations at $1 \times I_N$, inductive

Typical life 2-pole (IEC/EN 60934)

AC 240 V: 0.1...16 A 50,000 operations at $1 \times I_N$, inductive

DC 50 V: 0.1...16 A 50,000 operations at $1 \times I_N$, inductive

Typical life 3-pole (IEC/EN 60934)

3 AC 415 V: 0.1...16 A 30,000 operations at $1 \times I_N$, inductive

Ambient temperature -30...+60 °C (-22...+140 °F)

Insulation co-ordination (IEC 60664 and 60664 A) rated impulse withstand voltage 2.5 kV pollution degree 2
reinforced insulation in operating area

Dielectric strength (IEC 60664 and 60664A) test voltage operating area AC 3,000 V current path/current path AC 1,500 V

Insulation resistance > 100 MΩ (DC 500 V)

Interrupting capacity I_{CN} (EN 60934)

	I_N	U_N	I_{CN}
1, 2, 3-pole	0.1...2 A	AC 240 V/3 AC 415 V	$10 \times I_N$
1 pole	2.5...20 A	AC 240 V	200 A
2 pole	2.5...16 A	AC 240 V	300 A
3 pole	2.5...12 A	3 AC 415 V	150 A
3 pole	14...16 A	3 AC 415 V	130 A

Technical data

Rupture capacity I_{NC} (UL1077)

	I_N	U_N	I_{nc}
1, 2-pole	0.1...16 A	AC 250 V	3 500 A, C, 1
3-pole	0.1...12 A	3 AC 250 V	5 000 A, C, 1
1, 2-pole	0.1...16 A	AC 277 V	2 000 A, C, 1
1,2-pole	0.1...16 A	DC 50 V	2 000 A, C, 1

Degree of protection (IEC 60529/DIN 40050) operating area IP40 terminal area IP00

Vibration 5 g (57-500 Hz) ± 0.38 mm (10-57 Hz) to IEC 60068-2-6, test Fc
10 frequency cycles/axis

Shock 1-pole: 25 g (11 ms) 2 + 3-pole: 20 g (11 ms) to IEC 60068-2-27, test Ea

Corrosion 96 hours at 5 % salt mist, to IEC 60068-2-11, test Ka

Humidity 240 hours at 95 % RH, to IEC 60068-2-78, test Cab

Mass approx. 45 g (three pole)
approx. 31 g (double pole)
approx. 17 g (single pole)

Ordering information - 1-pole

Type No.	3130	single pole thermal circuit breaker
Mounting	F	Snap-in frame
Frame	1	Standard, panel cut-out 14.6 x 34 mm
	3	Panel cut-out 18.0 x 35-37 mm
Number of poles	1	single pole, thermally protected
Frame mounting	For Frame 1, snap-in, panel thickness 1.0-2.5 mm, color	
	0	black
	2	white
	4	grey
	For Frame 3, snap-in, panel thickness 1.5-3.2 mm, color	
	1	black
	3	white
	5	grey
Terminal design	P7	blade terminals 6.3 x 0.8 mm
	H7	for terminals 1.1, 2.1 3.1 terminal screws M 3.5 for terminals 1.2, 2.2, 3.2 blade terminals 6.3 x 0.8 mm
Characteristic curve	T1	thermal
Actuator style	W	rocker switch with marking „I“ and „O“ moulded in
Actuator colour	Rocker opaque without illumination	
	01 Q	black
	02 Q	white
	04 Q	red
	Rocker translucent white, with LED illumination	
	12 Q G	green
	12 Q R	red
	12 Q Y	yellow
	Rocker translucent color, with LED illumination	
	14 Q R	red
	15 Q Y	orange
	19 Q G	green
	Illumination voltage range ⁽¹⁾	
	2	10 - 14 V DC
	3	20 - 28 V DC
	6	90 - 140 V AC
	7	185 - 275 V AC
	9	225 - 330 V AC
	Current ratings	
	0.1...20 A	
3130 - F 1 1 0 - P7 T1 - W 14 Q R 3 - 5 A	ordering example	

Custom designed versions

Looking for a version you cannot find in our order numbering key?
Please get in touch. We will be pleased to find a solution for you.

Ordering information - multipole

Type No.	3130	multipole thermal circuit breaker
Mounting	F	Snap-in frame
Frame	1	Standard, panel cut-out size depending on no. of poles
	A	version for X3130
Number of poles	2	2-pole thermally protected
	3	3-pole thermally protected
	5	2-pole, 1-pole thermally protected
Frame mounting	0	Snap-in frame, black, panel thickness 1.0-2.5 mm for frame size 1
	A	2-pole, version for X3130
Terminal design	P7	blade terminals 6.3 x 0.8 mm (characteristic curve T1)
	H7	for terminals 1.1, 2.1 3.1 terminal screws M 3.5 for terminals 1.2, 2.2, 3.2 blade terminals 6.3 x 0.8 mm
Characteristic curve	T1	thermal
Actuator style	W	rocker switch with marking „I“ and „O“ moulded in
Actuator colour	Rocker opaque without illumination	
	01 Q	black
	02 Q	white
	04 Q	red
	Rocker translucent color, with LED illumination	
	14 Q R	red
	15 Q Y	orange
	16 Q T	blue
	19 Q G	green
	Illumination voltage range ⁽¹⁾	
	2	10 - 14 V DC
	3	20 - 28 V DC
	6	90 - 140 V AC
	7	185 - 275 V AC
	8	320 - 450 V AC
	9	225 - 330 V AC ⁽²⁾
	Current ratings	
	0.1...16 A	
3130 - F 1 3 0 - P7 T1 - W 14 Q R 7 - 5 A	ordering example	

Please observe our minimum ordering quantities

- (1) N/A for non-illuminated version
(2) for 2-pole variant only

ETA 3130 Thermal Overcurrent Circuit Breaker

Standard current ratings and typical internal resistance values

Current rating (A)	Internal resistance per pole (Ω)	Current rating (A)	Internal resistance per pole (Ω)
0.1	94	4	0.0435
0.2	24	5	0.0325
0.3	12	6	0.0215
0.4	5.30	7	0.0165
0.5	4.20	7,5	0.0165
0.8	1.50	8	0.0165
1	0.9	10	< 0.02
1.2	0.80	12	< 0.02
1.5	0.45	14	< 0.02
1.75	0.36	15	< 0.02
2	0.27	16	< 0.02
2.5	0.0785	18	< 0.02
3	0.0595	20	< 0.02
3.5	0.0565		

Dimensions 3130-F110-...

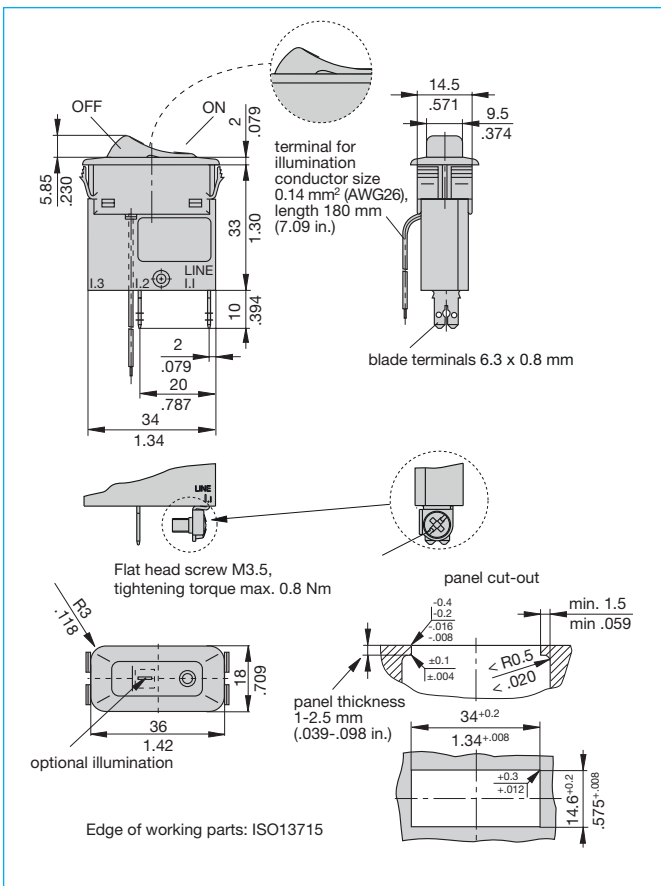

Dimensions 3130-F311-...

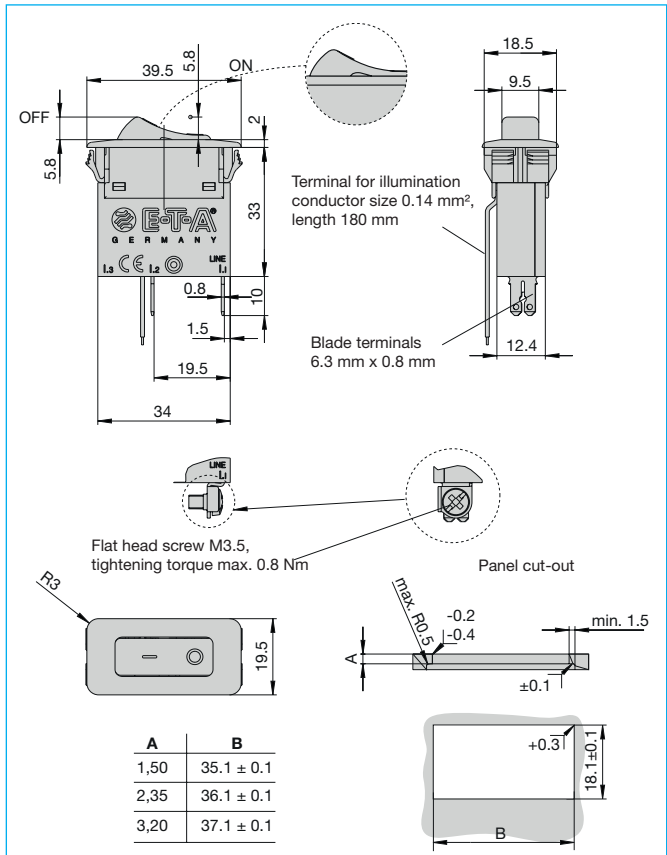

Dimensions 3130-F120-...

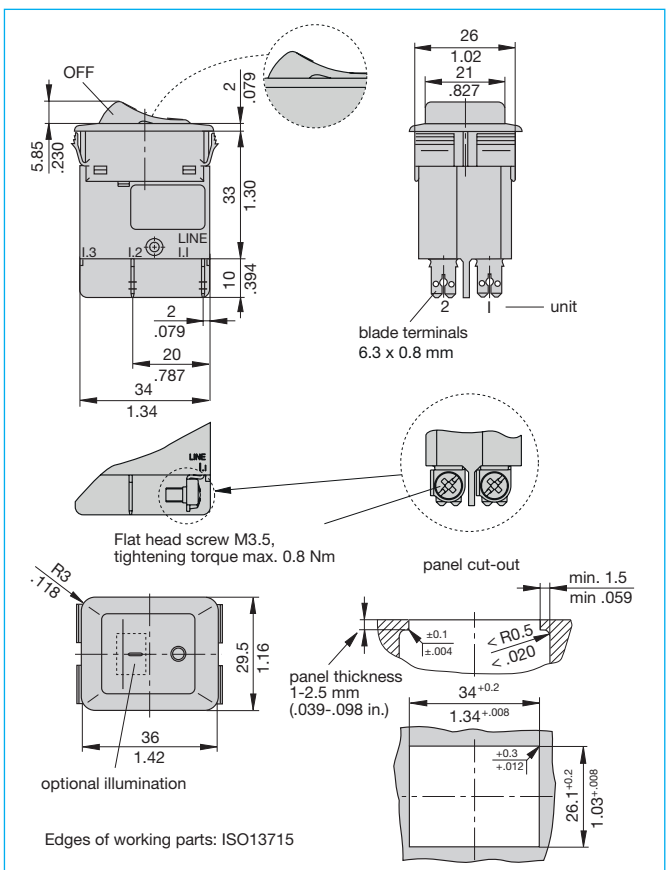

Dimensions 3130-F130-...

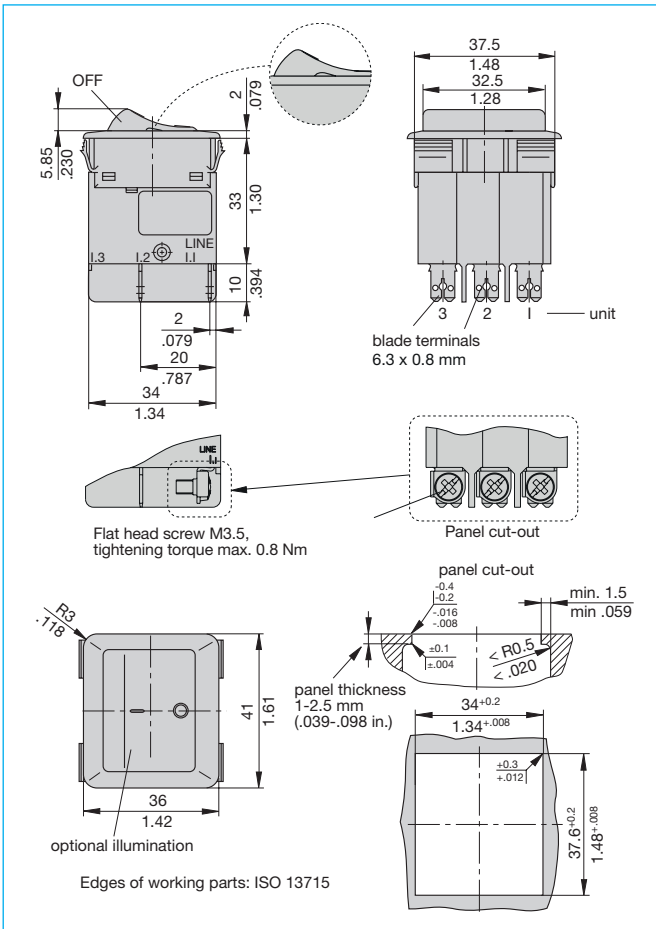

Installation drawing 3130-F1...

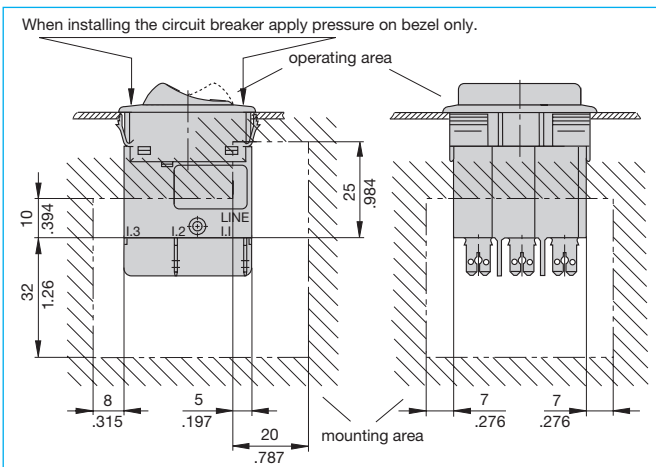

Internal connection diagrams

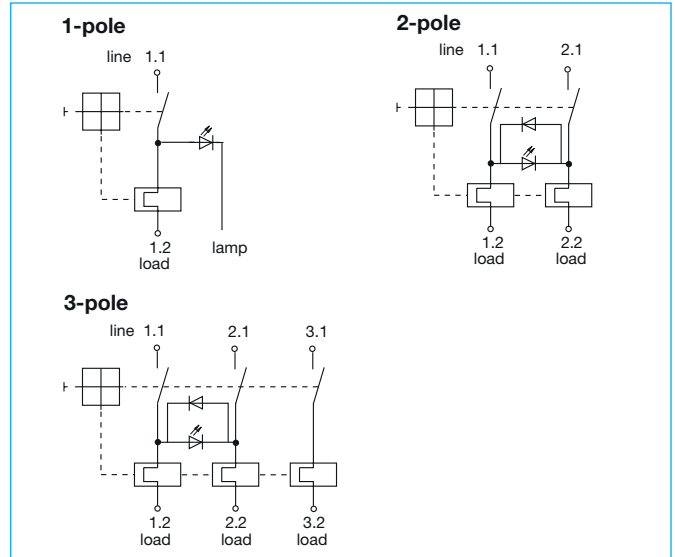

Accessories 3130-F130-...

Splash cover, transparent, for 3-pole version
X 221 258 01 (IP54), comprising bezel Y 306 109 01
 and transparent cover Y 306 108 01

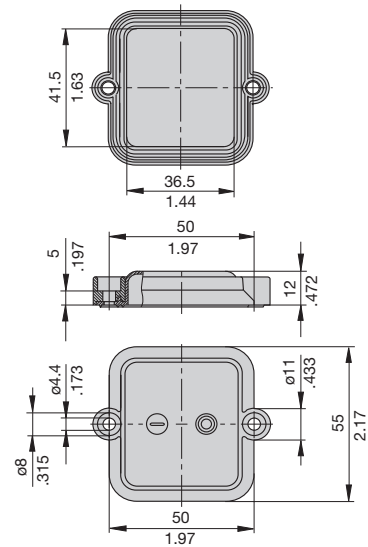

Typical time/current characteristics

Multipole types: all poles symmetrically loaded.
 With single pole overload, thermal tripping will be at approx. $1.54 \times I_N$ with 2-pole devices and at approx. $1.68 \times I_N$ with 3-pole devices.

0.1...2 A

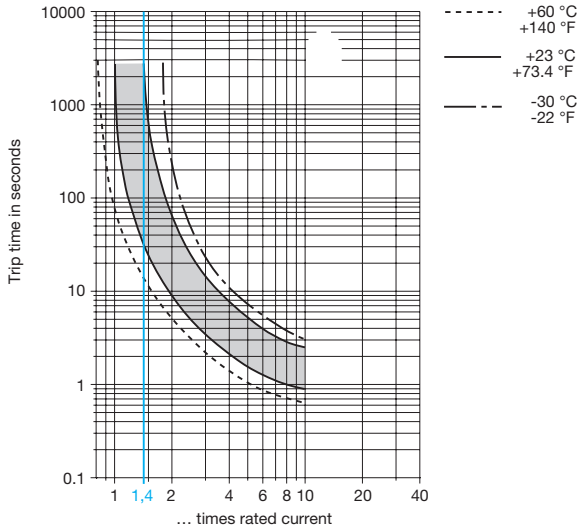

2.5...20 A 1-pole 2.5...16 A 2- and 3-pole

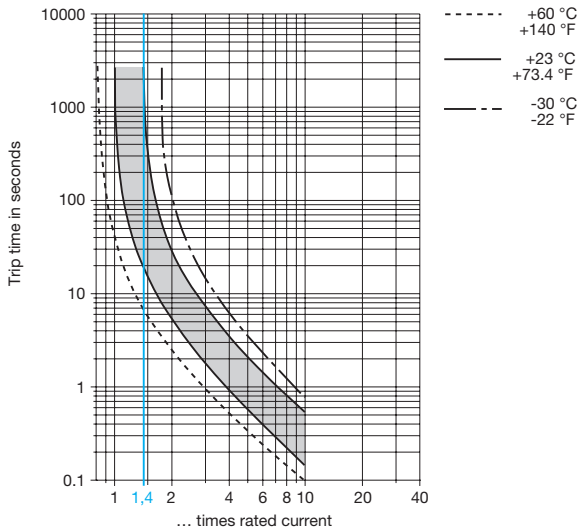

The time/current characteristic curve depends on the ambient temperature prevailing. In order to eliminate nuisance tripping, please multiply the circuit breaker current ratings by the derating factor shown below. See also section Technical information.

Ambient temperature	°F	-22	-4	+14	+32	+73.4	+104	+122	+140
°C		-30	-20	-10	0	+23	+40	+50	+60
Derating factor		0.8	0.84	0.88	0.92	1	1.08	1.14	1.23

This is a metric design and millimeter dimensions take precedence ($\frac{\text{mm}}{\text{inch}}$)

All dimensions without tolerances are for reference only. In the interest of improved design, performance and cost effectiveness the right to make changes in these specifications without notice is reserved. Product markings may not be exactly as the ordering codes. Errors and omissions excepted.

Description

The space-saving X3130 Power Entry Module with double pole circuit breaker 3130-FA.A combines three functions within a single component: A C14 appliance inlet and rocker switch with resettable overcurrent protection; screw mounting from the front or the rear.

Typical applications

Electrical medical apparatus, laboratory equipment, professional audio equipment and office machines.

Ordering information

Type No.

X3130 Power Entry Module for circuit breaker type 3130-FA.A

Module

A appliance inlet C14

Design

04 screw-type mounting

Accessories

00 without

Version

01 not wired; mounting position 3130:
0 to connector

11 wired; mounting position 3130:
0 to connector

Delivery condition

M module supplied with
circuit breaker FA.A

X3130 - A 04 00 01 - M Ordering example

Approvals

X3130-A – C14-appliance inlet

Authority	Standard	Rated voltage	Current ratings
ENEC	IEC/EN 60320-1	AC 240 V	10 A
UL/CSA	UL 60320-1, CSA C22.2 no. 60320-1	AC 250 V	15 A
CQC	CCC	AC 250 V	10 A

Please note: the current rating of the circuit breaker must not exceed the max. current of the appliance inlet, depending on approval.

Complete module X3130-A also available with approval according to UL 60320-1 at max. current of 15 A.

This is a metric design and millimeter dimensions take precedence ($\frac{\text{mm}}{\text{inch}}$)

All dimensions without tolerances are for reference only. In the interest of improved design, performance and cost effectiveness the right to make changes in these specifications without notice is reserved. Product markings may not be exactly as the ordering codes. Errors and omissions excepted.

Technical data

Rated voltage	AC 250 V
Rated current	10 A (IEC) 15 A (UL/CSA)
Ambient temperature	-25 °C ... 70 °C
Number of poles	L, N + ground
Cable cross section	max. 1.5 mm ²
Degree of protection	Class I
Mounting method	screw-type mounting (front or rear)
Terminal design	blade terminals 6.3 x 0.8 mm
Housing material	thermoplastics, black UL94V-0
Appliance inlet	C14 according to IEC/EN 60320-1
Switch	circuit breaker type 3130, 2-pole

Dimensions

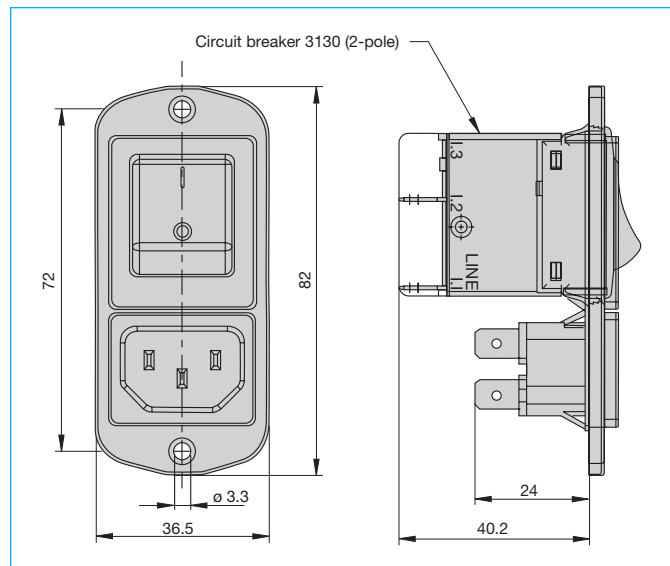

Mounting hole X3130

