

## **Metral 4 And 5 Row Right Angle Receptacle Insertion Tooling**

All standard Metral 4 and 5 row right angle receptacles (power and signal) can be installed with the same type tooling. (Not for High Speed. Please see information on High Speed connectors.)

The top tool is a modified “flat rock” press bar.

The bottom tool serves as a board support during insertion and is cleared out in the areas where the tails come through the PCB.

### **Top Tool Press Bar 162325-XXX**

If all of the Metral modules that are to be inserted are stacked end to end you can use a standard press bar. If you have groups of Metral connectors and then a space other than an even increment of 12mm then you will need a custom top tool.

#### **Standard Top Tools**

<b>162325-001</b>	8 (12mm) modules
<b>162325-002</b>	12 (12mm) modules
<b>162325-003</b>	21 (12mm) modules

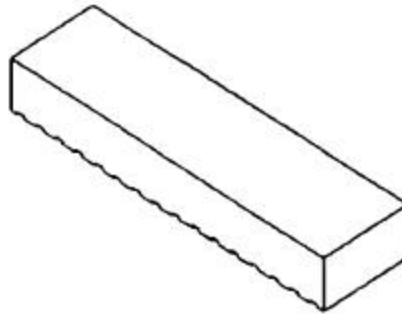

### **Board Supports (Bottom Tools) 162383-XXX**

Some Metral users prefer to develop their own board supports or use a PCB with oversized holes. Either of these practices are acceptable but FCI also offers bottom tools for those customers who prefer factory tooling. The bottom tools can be cut to the length needed.

#### **Standard bottom tools**

		Length
<b>162383-001</b>	146.8mm	5.780 inches
<b>162383-002</b>	194.8mm	7.669 inches
<b>162383-003</b>	302.8mm	11.921 inches
<b>162383-004</b>	457.2mm	18.000 inches
<b>162383-005</b>	609.6mm	24.000 inches

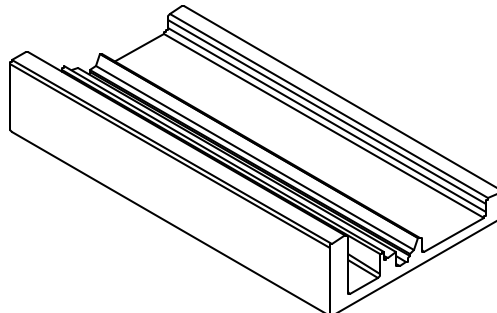

**MT-510 P/N 162452-001**

The MT-510 is a manually operated press that can insert up to 128 press fit pins in one stroke. It can also be used for solder tail parts that have press pegs. The MT-510 can be used for all standard Metral right angle receptacles and right angle headers.

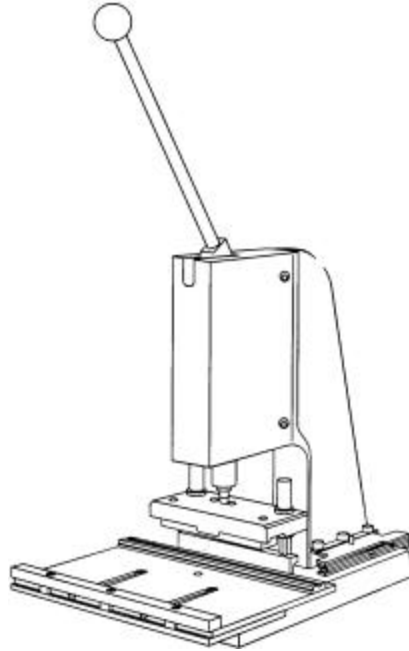

**MT-511 Insertion Press P/N 166380-001**

**Loading Station P/N 166505-001**

The MT-511 is a pneumatic machine that can terminate up to (21) 12mm modules per machine cycle. It can be used for all standard right angle receptacles and right angle headers. The optional loading station is used to stage the connectors prior to insertion.

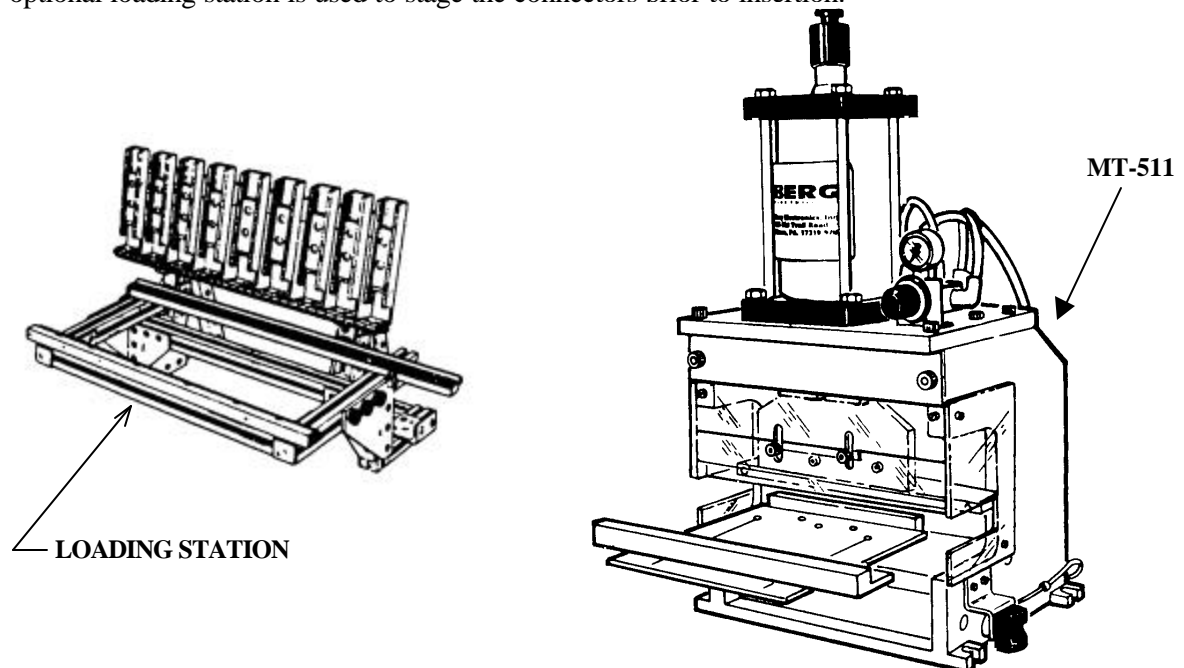

### **MT-120 Heat Stake Hand tool P/N 160508-001**

The MT-120 is a hand held single heat stake tool.

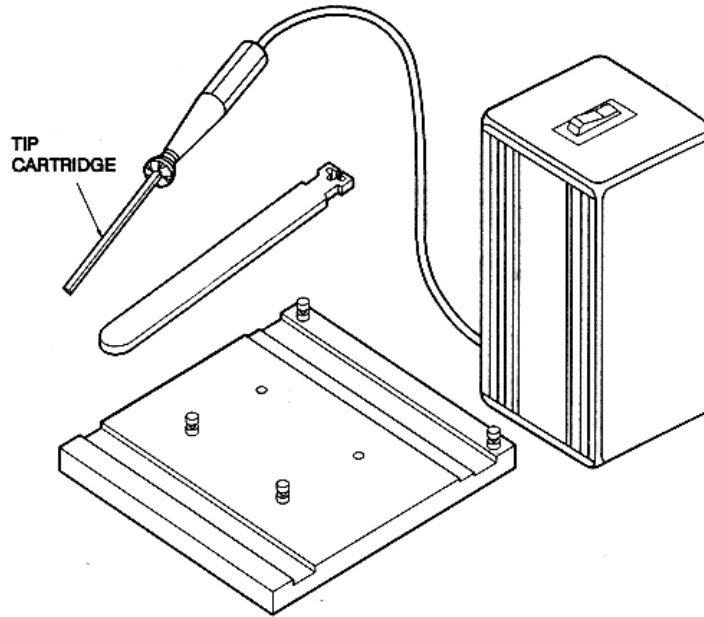

### **MT-130 Multiple Heat Stake Bench Tool P/N 160509-001**

The MT-130 terminates up to 32 heat stake pegs per cycle.

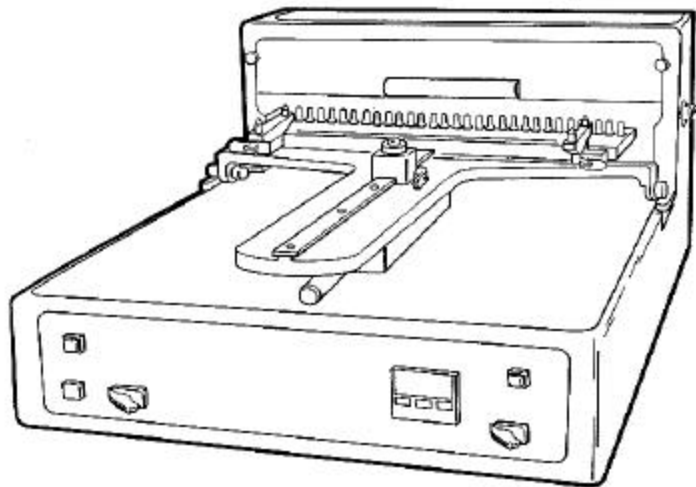

**Final Review**