

CM0805C601R-10

PHYSICAL DIMENSIONS:

A	2.00 [.079]	+ 0.20 [.008]
B	1.20 [.047]	+ 0.20 [.008]
C	1.20 [.047]	+ 0.20 [.008]
D	0.15 [.006]	+ 0.10 [.004]
T1	0.55 [.022]	+ 0.10 [.004]
T2	0.46 [.018]	+ 0.10 [.004]

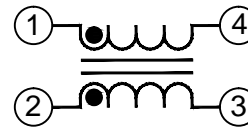
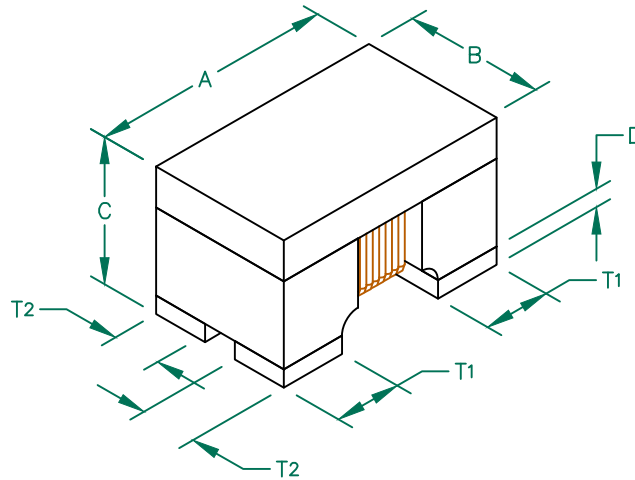

LAND PATTERNS FOR REFLOW SOLDERING

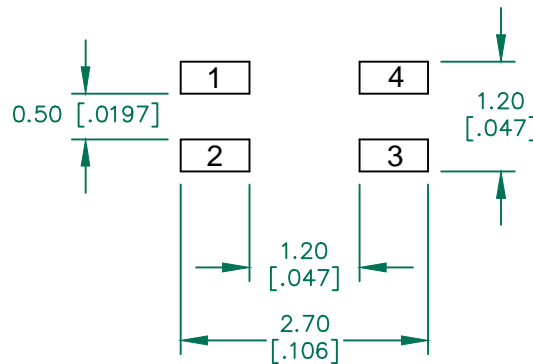

RECOMMENDED SOLDERING CONDITIONS

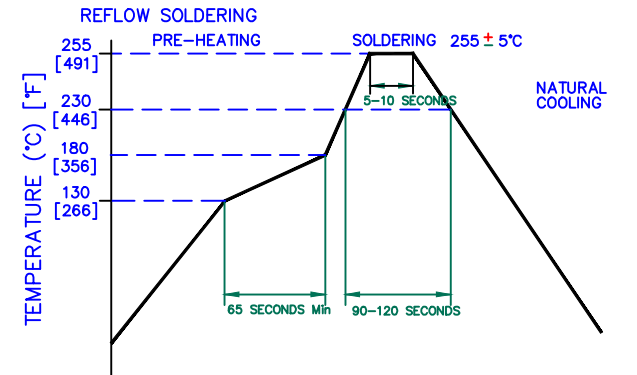

Z, R, XL vs. FREQUENCY

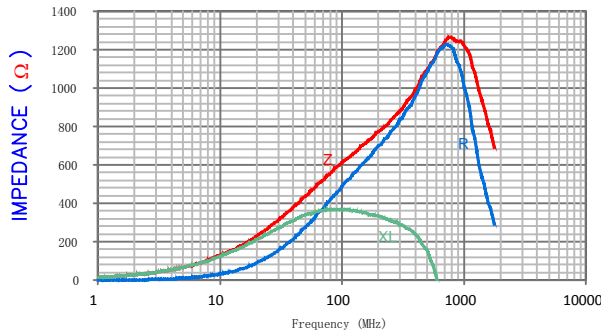

Z vs. FREQUENCY (C,N,O)

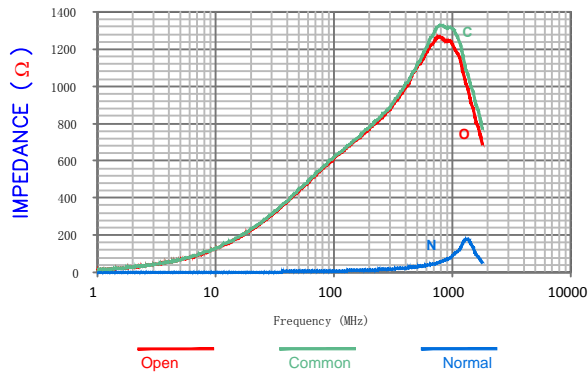

RoHS

Electrical Characteristics		Nominal	Min	Max
Common Mode Impedance @ 100MHz	(Ω)	600	450	750
DCR	(Ω)	-	-	0.375
Rated Current	(mA)	-	-	250

- NOTES: UNLESS OTHERWISE SPECIFIED
1. TAPED AND REELED per CURRENT EIA SPECIFICATIONS 7" REELS, EMBOSSED PLASTIC TAPE 2,000 PCS/REEL.
 2. TERMINATION FINISH 100% MATTE TIN.
 3. COMPONENTS SHOULD BE ADEQUATELY PREHEATED BEFORE SOLDERING.
 4. OPERATING TEMP. RANGE: -40°C~+125°C. (INCLUDING SELF-HEATING)
 5. COSMETIC SPECIFICATION REFER TO WI-QA-124

DIMENSIONS ARE IN mm [INCHES].				This print is the property of Laird Tech. and is loaned in confidence subject to return upon request and with the understanding that no copies shall be made without the written consent of Laird Tech. All rights to design or invention are reserved.		Laird	
PROJECT/PART NUMBER:				REV	PART TYPE:	DRAWN BY:	
B ADD OPERATING TEMPERATURE UPDATE LAIRD LOGO AND REFLOW CURVE				08/05/13	QU	CM CHOKE	JUN
DATE:				02/22/10	SCALE:	NTS	SHEET:
A ORIGINAL DRAFT				02/22/10	JUN		
REV				DESCRIPTION	DATE	INT	TOOL #
				CM0805C601R-10-B			1 of 1