

Sep.1.2022 Copyright 2022 HIROSE ELECTRIC CO., LTD. All Rights Reserved.
In case of consideration for using Automotive equipment / device which demand high reliability, kindly contact our sales window correspondents.

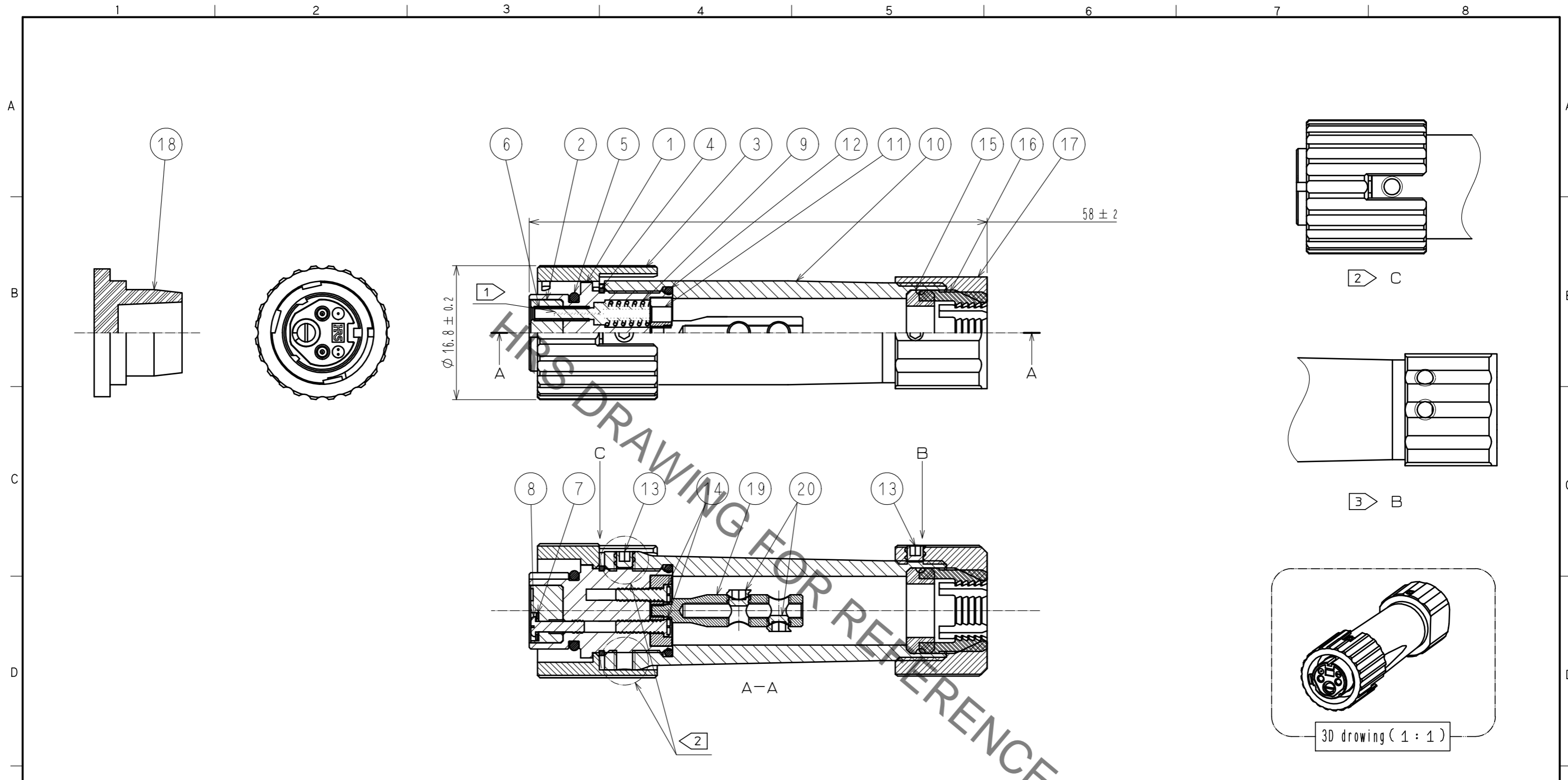

- NOTE
- 1 Ferrules are not included in this product. MU ferrules are separately available.
 - 2 Housing of part No. 10 has two holes for fixing with sleeve of part No. 1 by hexagon socket screw of part No. 13. Tighten the screw at either hole that is visible from a slit on the sleeve as shown in section C.
 - 3 Tightening ring of part No. 17 has two holes for fixing hexagon socket screw of part No. 13. Tighten the screw at visible either hole, or either hole if both holes are visible.
 - 4 For cleaning of the ferrule end, loosen the screw of part No. 8 and pick up the pre-assembled P shell B of part No. 2 by pulling the screw of part No. 8. Then, remove the split sleeves by using separately available sleeve-remover and clean the ferrules.

10	ZINC DIE CASTING	CHROME PLATING (COLOR:BLACK)	20	STAINLESS STEEL	_____
9	PIANO WIRE	ZINC PLATING + BAKING PROCESSING	19	STAINLESS STEEL	_____
8	STAINLESS STEEL	_____	18	SIR RUBBER	COLOR:BLACK
7	STAINLESS STEEL	_____	17	ZINC DIE CASTING	CHROME PLATING (COLOR:BLACK)
6	ZIRCONIA	_____	16	PA RESIN	COLOR:WHITE
5	NBR RUBBER	COLOR:BLACK	15	SIR RUBBER	COLOR:MILKY WHITE
4	STAINLESS STEEL	_____	14	STAINLESS STEEL	_____
3	ZINC DIE CASTING	CHROME PLATING (COLOR:BLACK)	13	STAINLESS STEEL	_____
2	ZINC DIE CASTING	CHROME PLATING (COLOR:BLACK)	12	CR RUBBER	COLOR:BLACK
1	ZINC DIE CASTING	CHROME PLATING (COLOR:BLACK)	11	ZINC DIE CASTING	NICKEL PLATING
NO.	MATERIAL	FINISH . REMARKS	NO.	MATERIAL	FINISH . REMARKS

UNITS	SCALE	COUNT	DESCRIPTION OF REVISIONS	DESIGNED	CHECKED	DATE
mm	2 : 1	△				
			APPROVED : MT. SHIBUTANI	18.02.02	DRAWING NO. EDC-179215-31-00	
			CHECKED : FS. YOSHIDA	18.02.02	PART NO. MF10B-WPS6.5CH02-0200(31)	
			DESIGNED : TY. SATO	18.02.02	CODE NO. CL709-1048-7-31	
			DRAWN : MK. INOUE	18.02.01	1/1	