

## DESCRIPTION

MP2935 is a high-efficiency, 4-phase, synchronous, buck-switching PWM controller with an SVID interface for high-performance Intel processors. The multi-phase PWM output signals can be configured for up to 4-phase operation with interleaved switching.

MP2935 adopts three-logic-level PWM outputs for enhanced noise immunity and flexible fault management. Depending on the power states set by SVID command, the multi-phase channel can switch between multiphase and single-phase operation. In addition, MP2935 supports programmable load-line resistance. As a result, the output voltage is always optimally positioned for a load transient.

The chip also provides accurate and reliable short-circuit protection with adjustable current limit threshold and a delayed VR\_RDY output that is masked during on-the-fly output voltage changes to eliminate false triggering. MP2935 performance is specified over the junction temperature range of -10°C to 125°C. The chip is available in 40-lead QFN package.

## FEATURES

- VR12.5 compliant
- Multi-Phase Operation at up to 2MHz per Phase
- Tri-State PWM Outputs for Driving MPS Intelli-Phase™ Devices
- Power-Saving Modes Maximize Efficiency During Light Load and Deeper-Sleep Operation
- Active Current Balancing between Output Phases
- Independent Current Limit and Load Line Setting Inputs for Additional Design Flexibility
- 8-bit Digitally Programmable 0V to 3.04V Output through Serial VID Interface
- Overload and Short-Circuit Protection with Latch-Off Delay
- Output Current Monitor
- Fault Latch Output
- Regulator Temperature Monitor
- Available in a 6mmx6mm 40-lead QFN package

## APPLICATIONS

- Power supplies for next-generation Intel® processors

All MPS parts are lead-free, halogen free, and adhere to the RoHS directive. For MPS green status, please visit MPS website under Quality Assurance.

"MPS" and "The Future of Analog IC Technology" are Registered Trademarks of Monolithic Power Systems, Inc.

TYPICAL APPLICATION CIRCUIT

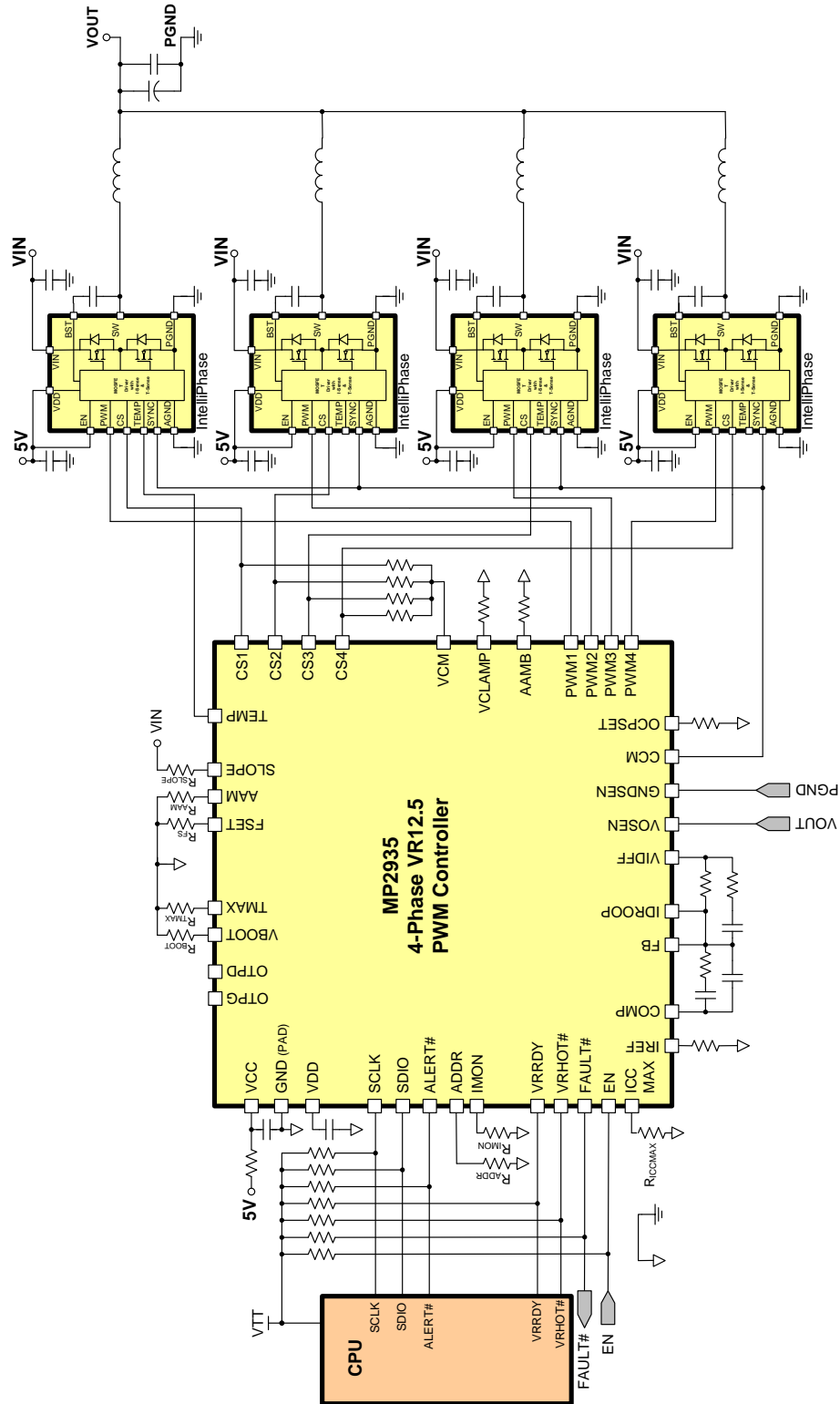

### ORDERING INFORMATION

Part Number*	Package	Top Marking	Junction Temperature (T <sub>J</sub> )
MP2935DQK	6x6mm QFN40	MP2935	-40°C to +125°C
MP2935ADQK	6x6mm QFN40	MP2935A	-40°C to +125°C

\* For Tape & Reel, add suffix -Z (e.g. MP2935DQK-Z).  
 For RoHS compliant packaging, add suffix -LF (e.g. MP2935DQK-LF-Z)

### PACKAGE REFERENCE

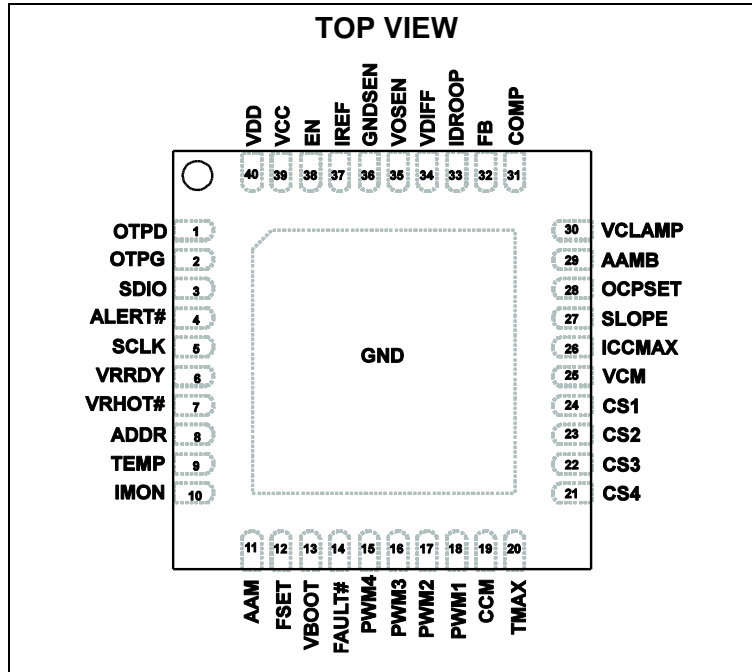

#### ABSOLUTE MAXIMUM RATINGS <sup>(1)</sup>

VCC .....	0.3V to +6.5V
VDD .....	-0.3V to +4.0V
GNDSEN .....	-0.3V to +0.3V
SLOPE .....	-0.3V to +26V
All Other Pins .....	-0.3V to (VCC+0.3V)
Continuous Power Dissipation (T <sub>A</sub> = +25°C) <sup>(2)</sup>	3.9W
Junction Temperature .....	150°C
Lead Temperature .....	260°C
Storage Temperature .....	-65°C to +150°C

#### Recommended Operating Conditions <sup>(3)</sup>

VCC .....	4.5V to 5.5V
Operating Junction Temp. ....	-40°C to +125°C

Thermal Resistance <sup>(4)</sup>	$\theta_{JA}$	$\theta_{JC}$	°C/W
6x6 QFN40 .....	32	8	

#### Notes:

- Exceeding these ratings may damage the device.
- The maximum allowable power dissipation is a function of the maximum junction temperature T<sub>J</sub>(MAX), the junction-to-ambient thermal resistance  $\theta_{JA}$ , and the ambient temperature T<sub>A</sub>. The maximum allowable continuous power dissipation at any ambient temperature is calculated by P<sub>D</sub>(MAX) = (T<sub>J</sub>(MAX)-T<sub>A</sub>)/ $\theta_{JA}$ . Exceeding the maximum allowable power dissipation will cause excessive die temperature.
- The device is not guaranteed to function outside of its operating conditions.
- Measured on JESD51-7, 4-layer PCB.

## ELECTRICAL CHARACTERISTICS

VCC = 5 V, GNDSEN = GND, EN = VCC, VID = 0.50 V to 3.04 V, Current going into pin is positive.  
 TA = -10°C to +100°C, unless otherwise noted.

Parameter	Symbol	Conditions	Min	Typ	Max	Units
<b>VOLTAGE ERROR AMPLIFIER</b>						
Error Amplifier Output Voltage Range <sup>(5)</sup>	V <sub>COMP</sub>		0.75		4.6	V
DC output Accuracy	V <sub>OUT</sub>	t <sub>A</sub> = 25°C. No load, closed-loop, measured at VOSEN pin to GNDSEN pin. Active mode range. VID=1.50V to 3.04V	-0.5		+0.5	%
		No load, closed-loop, measured at VOSEN pin to GNDSEN pin. Active mode range. VID=1.50V to 3.04V	-1		+1	%
		t <sub>A</sub> = 25°C. No load, closed-loop, measured at VOSEN pin to GNDSEN pin. Active mode range. VID=1.00V to 1.50V	-8		+8	mV
		No load, closed-loop, measured at VOSEN pin to GNDSEN pin. Active mode range. VID=1.00V to 1.50V	-15		+15	mV
		t <sub>A</sub> = 25°C. No load, closed-loop, measured at VOSEN pin to GNDSEN pin. Active mode range. VID=0.500V to 1.000V	-10		+10	mV
		No load, closed-loop, measured at VOSEN pin to GNDSEN pin. Active mode range. VID=0.500V to 1.000V	-15		+15	mV
Line Regulation	ΔV <sub>FB</sub>	V <sub>CC</sub> = 4.75 V to 5.25 V		0.3		%
Input Bias Current	I <sub>FB</sub>		-1		+1	μA
Output Source Current	I <sub>COMP</sub>	FB forced to (V <sub>VID</sub> - 3%), no droop		-3		mA
Output Sink Current	I <sub>COMP</sub>	FB forced to (V <sub>VID</sub> + 3%), no droop		+3		mA
Open Loop Gain <sup>(5)</sup>				80		dB
Unity Gain Bandwidth <sup>(5)</sup>	GBW <sub>(ERR)</sub>	COMP = FB		20		MHz
Slew Rate <sup>(5)</sup>		C <sub>COMP</sub> = 10 pF		25		V/μs
<b>REMOTE SENSE AMPLIFIER</b>						
Bandwidth <sup>(5)</sup>	GBW <sub>(RSA)</sub>			20		MHz
GNDSEN Current	I <sub>GNDSEN</sub>	GNDSEN=0.3V		10	400	μA
VOSEN Current	I <sub>VOSEN</sub>	VOSEN=1V		15	50	μA
<b>OSCILLATOR</b>						
FSET Voltage	V <sub>FSET</sub>	R <sub>FSET</sub> = 64.9kΩ to GND	0.9	1.0	1.1	V
Frequency Setting	f <sub>SW</sub>	t <sub>A</sub> = 25°C, R <sub>FSET</sub> = 64.9kΩ, 4-phase configuration	540	600	660	kHz
SLOPE Input Current Range <sup>(5)</sup>	I <sub>SLP</sub>	In normal mode	0		800	μA
		In shutdown, or in UVLO, SLOPE = 12 V	-1		+1	μA

**ELECTRICAL CHARACTERISTICS (continued)**

VCC = 5 V, GNDSEN = GND, EN = VCC, VID = 0.50 V to 3.04 V, Current going into pin is positive.  
 TA = -10°C to +100°C, unless otherwise noted.

Parameter	Symbol	Conditions	Min	Typ	Max	Units
<b>CURRENT-SENSE AND OVERCURRENT PROTECTION</b>						
Current Limit Level	I <sub>VCM_OC</sub>	R <sub>OCPSSET</sub> =80.6kΩ, sink current from VCM pin		1.27		mA
Droop Current	I <sub>DRP</sub>	I <sub>VCM</sub> = -400μA	-24	-25	-26	μA
		I <sub>VCM</sub> = +400μA	24	25	26	μA
<b>CURRENT BALANCE AMPLIFIER</b>						
Common Mode Range <sup>(5)</sup>	V <sub>CS_CM</sub>		1.0		3.5	V
Input Current	I <sub>CS</sub>	CSX=4V			1	μA
Masked Off-Time <sup>(5)</sup>	t <sub>OFFMSKD</sub>	Measured from PWM turn-off		350		ns
<b>SYSTEM INTERFACE CONTROL INPUTS</b>						
<b>EN</b>						
EN Low Threshold Voltage	V <sub>IL(EN)</sub>				0.4	V
EN High Threshold Voltage	V <sub>IH(EN)</sub>		0.8			V
EN High Threshold Hysteresis Voltage	V <sub>IH(EN)</sub>			100		mV
Enable High Leakage	I <sub>IH(EN)</sub>	EN=1.1V			2	μA
Enable Delay	T <sub>3</sub>	VCC≥UVLO, Vboot is not 0V, EN high to Vout ramping (see Figure 13)		2	5	ms
<b>THERMAL THROTTLING CONTROL</b>						
V <sub>TEMP</sub> ADC		Register 17h=64h (100°C)		0.9		V
VRHOT# Low Output Impedance		I <sub>VRHOT#</sub> = 20mA, TA=25°C		8	10	Ω
VRHOT# High Leakage Current			-1		1	μA
<b>IMON OUTPUT</b>						
IMON Current	I <sub>MON</sub>	I <sub>VCM</sub> = +400μA	24	25	26	μA
IMON Clamp Voltage	V <sub>IMONMAX</sub>	IMON = Float, I <sub>VCM</sub> = 400μA		1.3		V
IMON ADC		Register 15h=C8h		1		V
IMON ADC		Register 15h=64h		0.5		V
<b>VRRDY COMPARATOR</b>						
Under-Voltage Threshold	V <sub>DIFF</sub> (UV)	Relative to nominal DAC voltage		-300		mV
Over Voltage Threshold	V <sub>DIFF</sub> (OV)	Relative to nominal DAC voltage		400		mV
		Absolute voltage		3.30		V
Output Low Voltage	V <sub>VRRDY</sub> (L)	I <sub>VRRDY(SINK)</sub> = 4mA		60	250	mV
Output High Leakage	I <sub>VRRDY</sub>	V <sub>VRRDY</sub> = 3.3V			1	μA
Reverse Voltage Detection Threshold <sup>(5)</sup>	V <sub>OSEN</sub> (RV)	Relative to GNDSEN, V <sub>DIFF</sub> falling		-300		mV
		Relative to GNDSEN, V <sub>DIFF</sub> rising		-100		mV

**ELECTRICAL CHARACTERISTICS (continued)**

VCC = 5 V, GNDSEN = GND, EN = VCC, VID = 0.50 V to 3.04 V, Current going into pin is positive.  
 TA = -10°C to +100°C, unless otherwise noted.

Parameter	Symbol	Conditions	Min	Typ	Max	Units
<b>CCM OUTPUT</b>						
Output Low Voltage	V <sub>OL</sub>	I <sub>SINK</sub> = 400μA		10	200	mV
Output High Voltage	V <sub>OH</sub>	I <sub>SOURCE</sub> = 400μA	4.8	5		V
<b>PWM OUTPUTS</b>						
Output Low Voltage	V <sub>OL</sub> (PWM)	I <sub>PWM(SINK)</sub> = 400μA		10	200	mV
Output High Voltage <sup>(5)</sup>	V <sub>OH</sub> (PWM)	I <sub>PWM(SOURCE)</sub> = 400μA	4.8	5		V
PWM Tri-State Leakage		PWM = 2.5V	-1		1	μA
<b>SUPPLY</b>						
VCC UVLO Threshold Voltage	VCC <sub>UVLO</sub>	VCC is rising		4.1	4.45	V
UVLO Hysteresis				200		mV
Supply Current	I <sub>VCC</sub>	EN=high. Both SVID bus and internal ID bus are idle. No load condition. 4-phase configuration. PWMs not switching.		8	16	mA
		EN = 0V		50	250	μA
<b>VDD REGULATOR</b>						
VDD Regulator Output Voltage	VDD			3.2		V
<b>SVID Interface (SCLK, SDIO, ALERT#)<sup>(5)</sup></b>						
Leakage current	I <sub>L</sub>	Pull-up voltage: 0V to 1.1V	-10		10	μA
Pin Capacitance <sup>(5)</sup>	C <sub>PIN</sub>				5	pF
Buffer ON Resistance <sup>(5)</sup>	R <sub>ON</sub>		4	8	13	Ω
VR Clock to Data Delay <sup>(5)</sup>			4		8.3	ns
Setup Time <sup>(5)</sup>				7		ns
Hold Time <sup>(5)</sup>				14		ns

**ELECTRICAL CHARACTERISTICS (continued)**

VCC = 5 V, GNDSEN = GND, EN = VCC, VID = 0.50 V to 3.04 V, Current going into pin is positive.  
 TA = -10°C to +100°C, unless otherwise noted.

Parameter	Symbol	Conditions	Min	Typ	Max	Units
<b>ADC</b>						
Voltage Range		Reads FF.		1.28		V
ADC Resolution				5		mV
ADC Sampling Rate <sup>(5)</sup>				3000		Hz
DNL <sup>(5)</sup>					1	LSB
Conversion Time <sup>(5)</sup>				30		µs
<b>DAC Slew rate (MP2935)</b>						
Soft-Start Slew Rate				2.5		mV/µs
SetVID_Slow Slew Rate				2.5		mV/µs
SetVID_Fast Slew Rate				10		mV/µs
<b>DAC Slew rate (MP2935A)</b>						
Soft-Start Slew Rate				5		mV/µs
SetVID_Slow Slew Rate				5		mV/µs
SetVID_Fast Slew Rate				20		mV/µs
<b>DAC</b>						
DAC resolution				8		Bits
LSB				10		mV
DNL				±1		LSB
INL				±1		LSB
Tolerance			-1		1	mV
<b>1/2/3/4 Phase Detection</b>						
PWM Sink Current				100		µA
PWM Detection Threshold Voltage			2	2.5	3.2	V
Phase Detect Timer <sup>(5)</sup>				50		µs

**Notes:**

5) Guaranteed by design or characterization data, not tested in production.

**PIN DEFINITION**

Pin #	Name	I/O	Description
1	OTPD	I	Factory OTP programming only. Connect to VCC for normal operation.
2	OTPG	I	Factory OTP programming only. Connect to GND for normal operation.
3	SDIO	I/O	Data Signal between CPU and Serial VID Controller.
4	ALERT#	O	Alert Signal from VID Controller to CPU.
5	SCLK	I	Source Synchronous Clock from CPU.
6	VRRDY	O	VR Ready Output. Open drain output signal.
7	VRHOT#	O	Voltage Regulator Thermal Throttling Logic Output. Actively pulls low if temperature at the monitoring point connected to TEMP exceeds the programmed VRHOT# temperature threshold.
8	ADDR	I	SVID Address setting pin. Refer to Table 6 for address assignment.
9	TEMP	I/O	Analog Temperature Signal Input.
10	IMON	O	Analog Total Load Current Signal. Sources a current proportional to the sensed total load current. Connect a resistor from IMON to GND to program the gain.
11	AAM	I	Advanced Asynchronous Mode (AAM) Timing Control Input. A resistor between this pin to ground sets the AAM mode turn-on threshold voltage.
12	FSET	I	Multiphase Frequency-Setting Input. A resistor connected between FSET and GND sets the oscillator frequency. The phase switching frequency will be divided by number of the operating phase.
13	VBOOT	I/O	V <sub>BOOT</sub> Voltage Set. Refer to Table 3 for VBOOT voltage assignment.
14	FAULT#	O	VR Fault#. Asserts low to notify the platform of a VR fault condition.
15	PWM4	O	Tri-State Logic-Level PWM Outputs. Connecting the PWM2 and/or PWM3 and/or PWM4 outputs to VCC turns off that phase, allowing MP2935 to change the number of operating phases. The operating phase number is decided when the part is enable. The number of operating phase cannot be changed on-the-fly.
16	PWM3	O	
17	PWM2	O	
18	PWM1	O	
19	CCM	O	Forced CCM Operation Enable. CCM stays high in Power States 00 and 01. Actively pulls low when in Power States 02 and 03 to enable DCM operation of the power stage. Connect it to the SYNC pin of Intelli-Phases™.
20	TMAX	I	Max. Temp. Set. Connect a resistor from TMAX to GND to set the maximum temperature.
21	CS4	I	Current Balance Inputs. Measures the current level in each phase. Float CS pins of unused phases.
22	CS3	I	
23	CS2	I	
24	CS1	I	
25	VCM	O	Buffered 2.5V reference.
26	ICCMAX	I	ICCMAX setting. Set the pin voltage to program the desired ICCMAX level.



**PIN DEFINITION (continued)**

Pin #	Name	I/O	Description
27	SLOPE	I	PWM Slope Current Input. Connect a 100K $\Omega$ resistor from VIN (system's 12V input voltage) to this pin to set the internal slope for PWM comparator.
28	OCPSET	I	Total Current Limit Setting.
29	AAMB	I	Combine with AAM pin, this pin sets the AAM mode threshold voltage.
30	VCLAMP	I	Connect a resistor to ground to set the per phase current limit.
31	COMP	I/O	Error Amplifier Output.
32	FB	I	Inverting Input of Error Amplifier.
33	IDROOP	O	Droop Current Output. Sources current that is proportional to the sensed output current.
34	VDIFF	O	Differential Amplifier Output.
35	VOSEN	I	Remote Core Voltage Sense Input. Connect to VCCSENSE at microprocessor die.
36	GNDSEN	I	Remote Voltage Sensing Return. Connect to ground at microprocessor die.
37	IREF	I	Internal Bias Current Set. Connect an 80.6k $\Omega$ resistor from IREF to GND.
38	EN	I	Chip Enable.
39	VCC	I	5V supply voltage for the controller. Need a 1 $\mu$ F capacitor for decoupling.
40	VDD	O	3.3V LDO output for internal digital circuit only. Need a 1 $\mu$ F capacitor for decoupling. Do not connect to any other load.
PAD	GND	I/O	Ground.

## TYPICAL PERFORMANCE CHARACTERISTICS

Performance waveforms are tested on the evaluation board of the Design Example section.

$V_{IN} = 12V$ ,  $V_{CC} = 5V$ ,  $V_{OUT} = 1.85V$ ,  $I_{OUT} = 0A$ ,  $600kHz$ , unless otherwise noted.

### Enable Startup

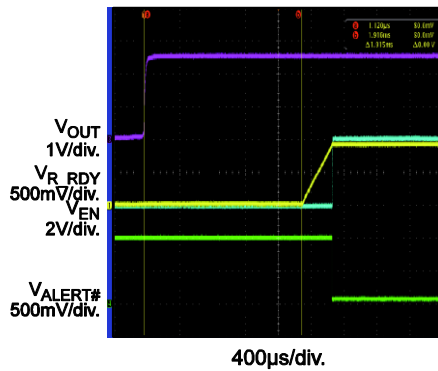

### Enable Shutdown

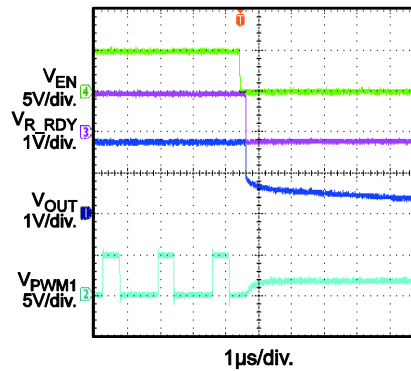

### Power State 1

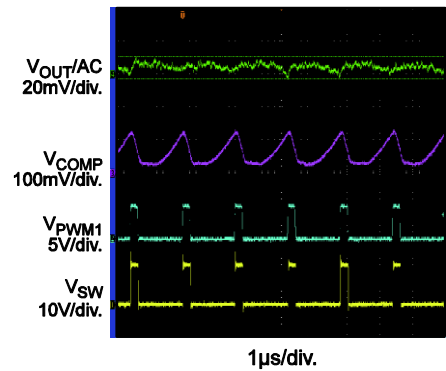

### Power State 2/3

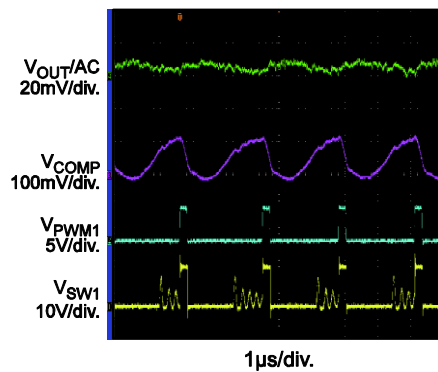

### Phase Shift

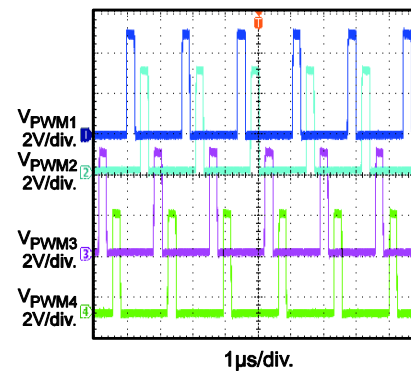

### Under Voltage Protection

Forced 1.55V to  $V_{DIFF}$

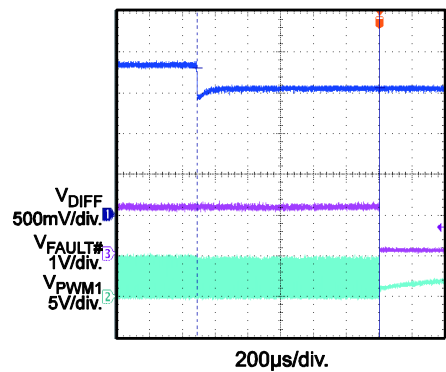

### Over Voltage Protection #1

Forced 2.25V to  $V_{DIFF}$

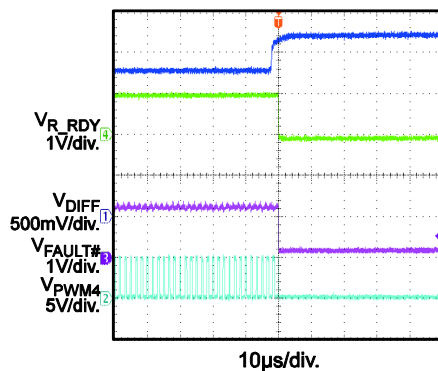

### Over Voltage Protection #2

Forced 3.4V to  $V_{DIFF}$  during VID Ramping

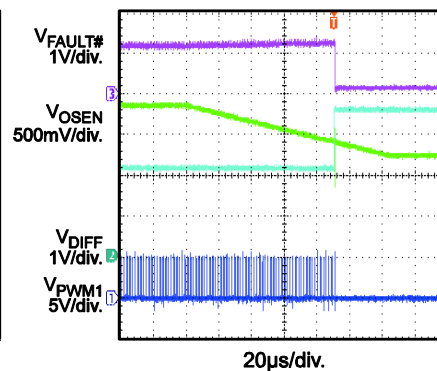

### Over Current Protection

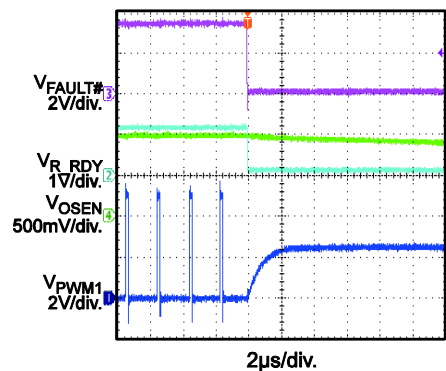

### FUNCTIONAL BLOCK DIAGRAM

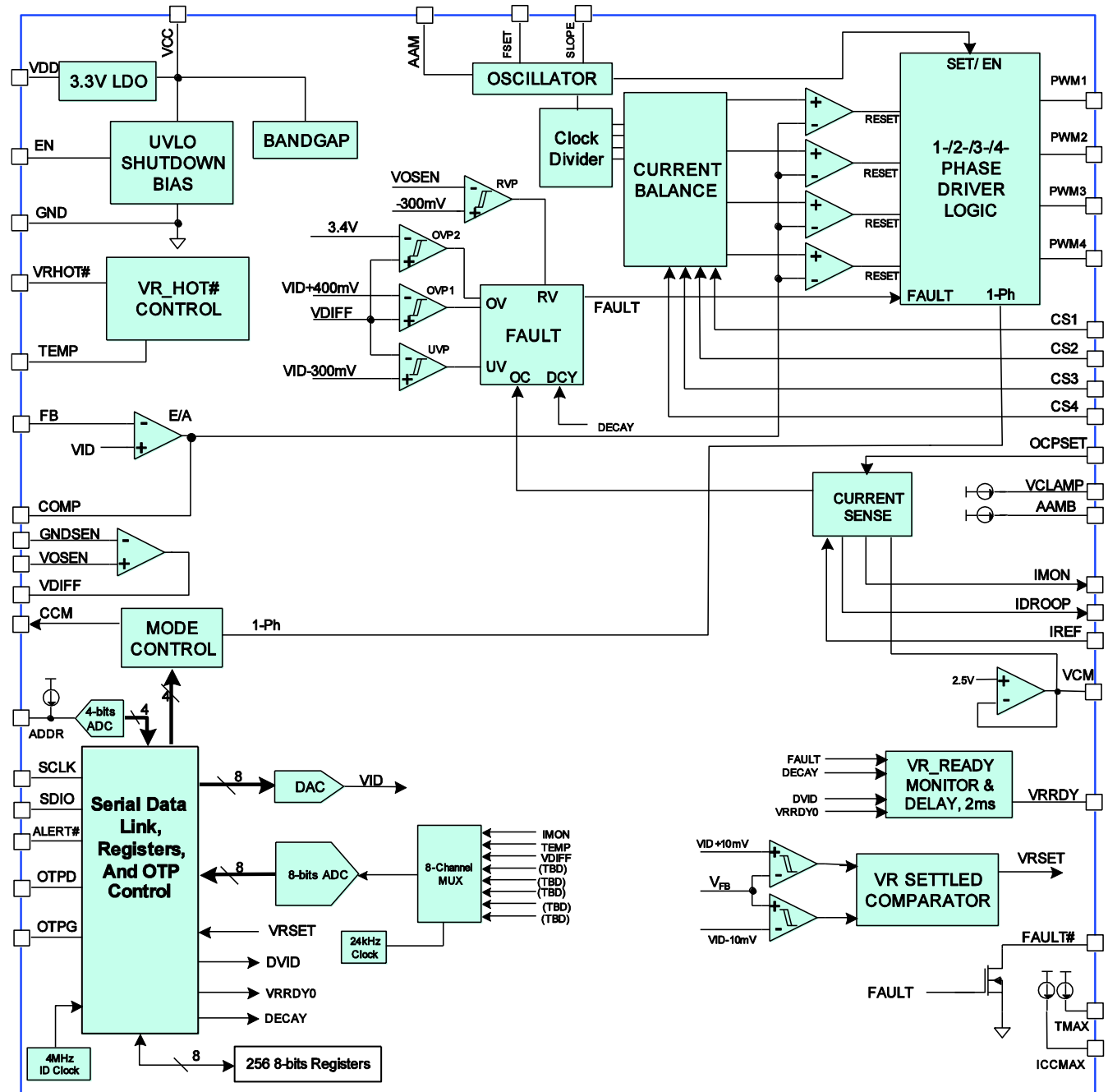

## OPERATION

MP2935 is a 4-phase VR12.5-compliant controller for Intel microprocessors. It is a multiphase controller for up to 4-phase operation and is capable for multi-mode PWM/advanced asynchronous mode (AAM) operation to maximize the efficiency over the load range. It includes blocks for a precision DAC, remote voltage-sense amplifiers, an error amplifier, a ramp generator with input voltage feed-forward, a PWM comparator, AAM control, load-line set, a VR-ready (VRRDY) monitor, a temperature monitor and serial VID (SVID) registers. It also includes dynamic-phase current balancing and phase shedding. Protection features include under-voltage lockout (UVLO), over-current protection (OCP), over-voltage protection (OVP), under-voltage protection (UVP) and reverse voltage protection (RVP).

### PWM Operation

MP2935 uses constant-switching-frequency current mode control and trailing-edge PWM operation with injected valley current signals. The PWM ramp of each phase combines with the sensed valley current to determine phase-current balance. Figure 1 shows the operation principles. The phase clock turns the PWM on. When the combined ramp voltage hits  $V_{COMP}$  voltage the

PWM turns off. The phase shift is applied between operating phases to minimize the input and output current ripple.

In general, the controller needs to wait for the next clock during a load step transient to turn on the PWM to support the load current. The waiting time causes the extra output voltage to drop. To maximize the current support to reduce the output voltage drop during the transient load, MP2935 employs FAST-PWM™ mode to respond immediately. During the load-step transient, the output voltage drop causes  $V_{COMP}$  to rise. When  $V_{COMP}$  rise fast enough to trigger the FAST-PWM threshold, the controller overrides the phase clock and turns on all PWMs without phase shifts. The PWM OFF of each phase is the same as for normal operation when the combined ramp hits  $V_{COMP}$  voltage. This FAST-PWM mode maximizes the regulator's di/dt slew rate to support the output load transient step and minimize the  $V_{OUT}$  drop.

When the power state is not PS0, the chip operates in single phase with AAM mode to maximize the efficiency in light load condition. A detailed description of AAM mode operation is described in "AAM Control Operation and Diode Emulation."

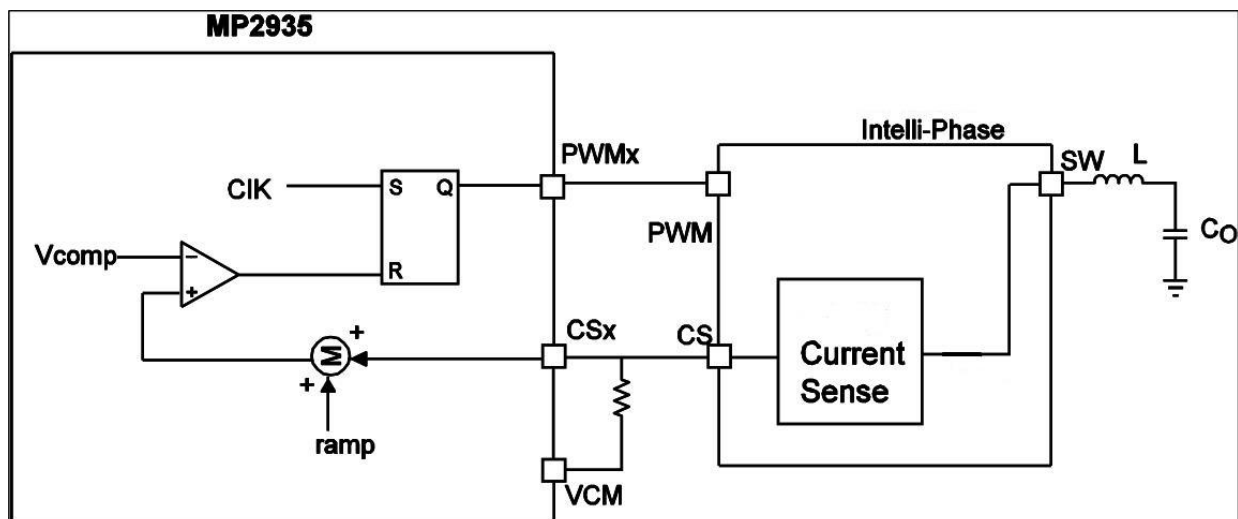

**Figure 1: Block Diagram of PWM Operation**

### PWM Operation and Power States

The user can select the total number of operating phases for MP2935, as described in “Switching Frequency and the Number of Operating Phases.” Based on the power states, the actual operating phase dynamically switches between full phases or single phase to optimize the power conversion efficiency at heavy and light CPU loads.

In PS0, MP2935 runs in full-phase PWM mode. While in light-load mode, PS1 to PS3, only Phase 1 is in operation to maximize power conversion efficiency. During the dynamic VID transition issued by SVID commands of either SetVID\_Fast or SetVID\_Slow, the power state changes to PS0 by default and runs in full-phase PWM mode.

In addition to changing the number of phases, the operation mode can change dynamically. In PS0 mode, MP2935 runs in multiphase PWM mode with switching frequency controlled by the master clock. In other power states, MP2935 switches to AAM mode where the switching frequency is no longer controlled by the master clock, but by the ripple voltage on the COMP pin. Thus, the switch frequency varies with the load current, resulting in maximum power conversion efficiency in low power states.

In PS2 and PS3, diode emulation mode is enabled to maximize the efficiency at light load condition.

The VR will switch back to AAM mode if the over current alarm is clear before latch-off.

Table 1 summarizes the dynamically changes to phase number and operation modes based on the power state register set through SVID commands.

The power states are listed in order of power savings:

- PS0 represents full power or Active mode
- PS1 is used in Active Mode or Idle Mode and represents a low current state, similar to PS1# definition in VR11.1 or IMVP6.5; it typically has a load < 20A. MP2935 runs in single phase (PWM1 only) AAM/continuous current modulation (CCM) mode.

- PS2 is used in Sleep Mode and it represents a lower current state than PS1; it typically has a load < 5A. MP2935 runs in single phase (PWM1 only) AAM with diode emulation enabled.
- PS3 (Mode[1,0]= “11”) is ultra-low current mode, lower than PS2; it typically has a load < 1A. MP2935 runs in single phase (PWM1 only) AAM with diode emulation enabled.

**Table 1: Phase Number and Operation Modes**

Power State	Operating Phases	CCM	PWM/AAM
0	Full phases	1	PWM
1	1	1	AAM
2	1	0	AAM
3	1	0	AAM

### AAM Control Operation and Diode Emulation

With the exception of PS0, all other power states enable AAM mode and run in single phase operation. Figure 2 shows typical AAM mode operation where switching frequency is no longer controlled by the master clock, but by the ripple voltage on the COMP pin.

PWM1 is set high when  $V_{COMP}$  reaches the AAM threshold voltage which is set by two resistors, from AAM pin to GND and from AAMB pin to GND.

AAM Threshold Voltage

$$= \frac{15400 \times V_{OUT}}{R_{AAM}} + I_{MON} \times R_{AAMB} + V_{COMMON}$$

$$R_{AAMB} = \frac{16 \times R_{CS}}{N}$$

$$R_{AAM} = \frac{15400 \times V_{OUT}}{V_{AAM\_Fraction}}$$

$$V_{AAM\_Fraction} =$$

$$\frac{V_{OUT}}{F_{SW} \times 3.424 \times 10^{-6}} - 0.5 \times I_{L\_PK-PK} \times R_{CS} \times 10 \times 10^{-6}$$

$V_{COMMON}$  is about 1V.  $V_{AAM\_Fraction}$  is part of the AAM threshold voltage. N is the number of

active phase during PS0.  $I_{L\_PK-PK}$  is the peak to peak inductor current.

$$I_{L\_PK-PK} = \frac{V_{OUT} \times (V_{IN} - V_{OUT})}{V_{IN} \times L \times F_{SW}}$$

Whenever PWM is high,  $V_{RAMP}$  ramps up from 1V with a slew rate programmed by the current flowing into the SLOPE pin. When  $V_{RAMP}$  reaches  $V_{COMP}$ , PWM resets to low.

The CCM pin is tied to the SYNC pin of the Intelli-Phase™. When the CCM pin is low, it enables diode emulation mode. In diode

emulation mode the low side MOSFET turns OFF once the inductor current reverses to keep the inductor current at 0A until the next PWM ON pulse.

In both PS0 and PS1, the CCM pin is high so the controller operates in CCM mode, which allows for negative inductor current.

In PS2 and PS3, the CCM pin is low to enable diode emulation mode on the Intelli-Phase™, allowing Diode Emulation mode operation.

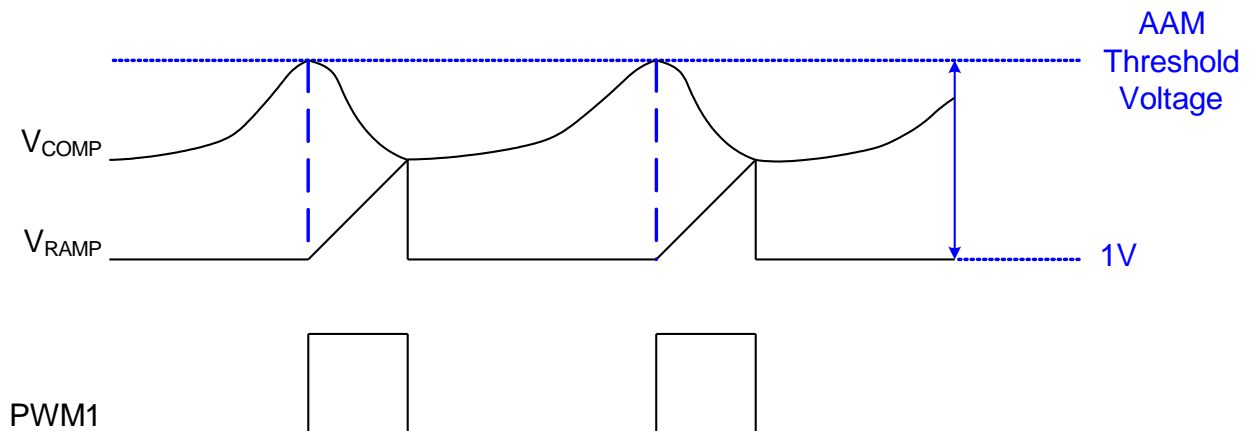
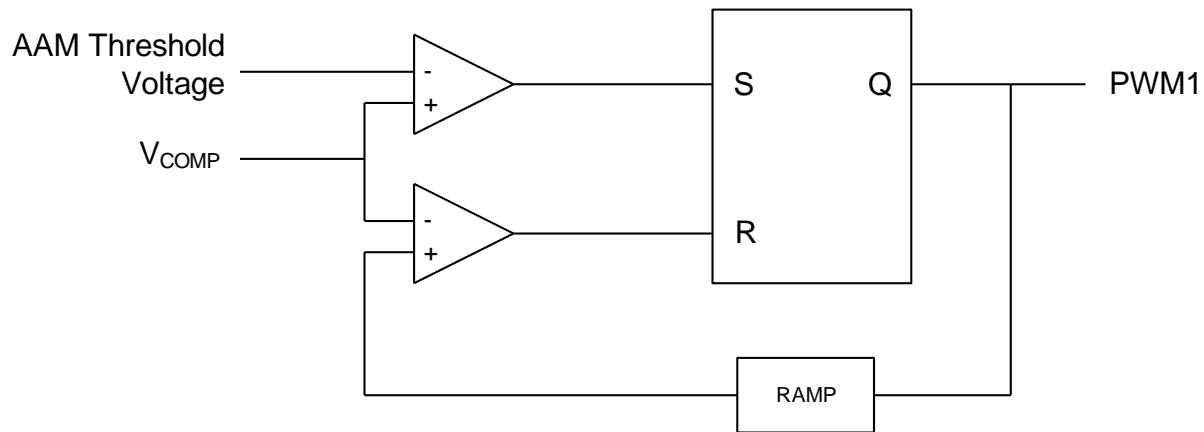

**Figure 2: Block Diagram of AAM Operation and Typical Waveforms**

### Switching Frequency and the Number of Operating Phases

In normal operation in the PS0 power state, an external resistor connected from the FSET pin to ground determines the clock frequency. To determine the switching frequency per phase, divide the clock by N, the number of phases, in use. If phase 4 is disabled by pulling up PWM4 to VCC, then divide the master clock by 3 for the frequency of the remaining phases. If both PWM3 and PWM4 are pulled up to VCC, then divide the master clock by 2 for the frequency of the remaining phases. If PWM2, PWM3 and PWM4 are pulled up to VCC, then the switching frequency of phase 1 equals the master clock frequency. If all phases are in use, then divide the master clock by 4.

$$R_{FSET} = 340000 \times (F_{SW} \times N)^{-1.106}$$

In single-phase AAM mode, the switching frequency is almost constant, until it enters DCM mode then the frequency decrease proportionally with load current.

### Current Sensing and IMON

MP2935's works seamlessly with the Intelli-Phase™ family to accurately sense output current to monitor the total output current to support Adaptive Voltage Positioning (AVP) and current limit detection. Simply direct the total sensed phase current from all of the Intelli-Phases's™ CS pins to VCM pin. When utilizing the Intelli-Phase's™ accurate current sense output, it eliminates sensing error due to inductor DCR variation and removes design effort on DCR thermal compensation. This simple configuration is shown in Figure 3.

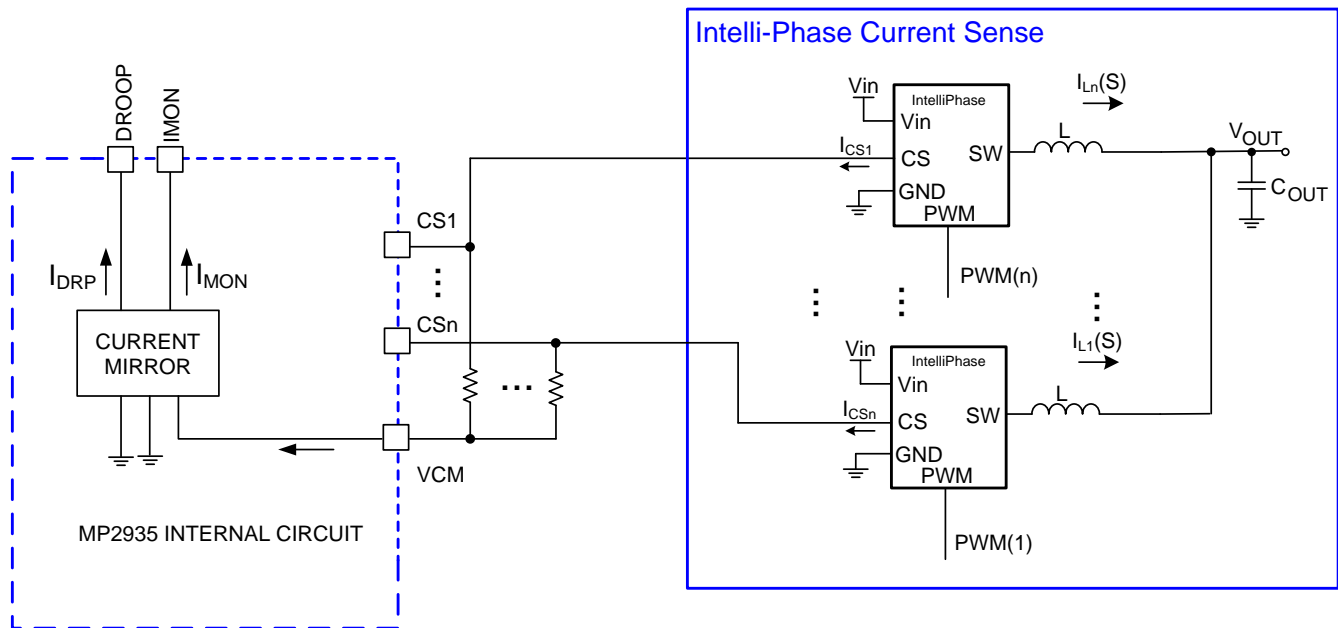

**Figure 3: Intelli-Phase™ Current Sensing Circuit**

The IMON current is a current proportional to VCM pin current,  $I_{MON} = \frac{I_{VCM}}{16}$ . A resistor,  $R_{IMON}$ , from IMON pin to GND sets the gain from average sensed inductor current to IMON voltage. A 1nF capacitor added in parallel with  $R_{IMON}$  filters the voltage ripple reflected from the inductor ripple current.

$$R_{IMON} = \frac{2048000}{ICCMAX}$$

If the desire ICCMAX is 100A, then select 20.5KΩ for  $R_{IMON}$ .

The voltage on the IMON pin is clamped to prevent it from going above 1.3V. An 8-bit ADC converts the IMON voltage to the  $I_{OUT}$  register. An IMON voltage of 1.28V indicates the current has reached the value represented in the ICC\_MAX register.

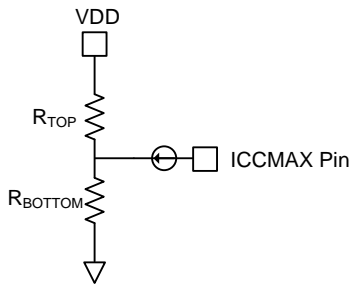

$$R_{TOP} = \frac{(VDD - 0.005 \times ICCMAX) R_{BOTTOM}}{0.005 \times ICCMAX - 2 \times 10^{-5} \times R_{BOTTOM}}$$

Set the ICCMAX register with a resistor divider

from VDD voltage. VDD is a 3.3V output voltage from the controller. Using a smaller resistance for  $R_{BOTTOM}$  will reduce variation. Let's say we choose  $R_{BOTTOM}$  to be 499Ω and the desired maximum current is 100A ( $ICCMAX=100A$ ), then  $R_{TOP}$  is calculated to be 2851Ω. To get the best possible accuracy, use two resistors to match the calculated resistance.

### Phase Current Sensing

MP2935 has individual inputs to monitor the current in each phase. The phase current information is combined with an internal ramp to create a current-balancing feedback system that is optimized for initial current accuracy and dynamic thermal balance. The current balance information is independent of the total inductor current information used for voltage positioning. The magnitude of the internal ramp can be programmed to optimize the transient response of the system. MP2935 also monitors the supply voltage to achieve feed-forward control whenever the supply voltage changes. A resistor connected from the power input voltage rail to SLOPE pin determines the slope of the internal PWM ramp.

$$\text{Slope} = \frac{1}{8} \times \frac{V_{IN}}{R_{SLOPE} + 7000\Omega} \times \frac{1}{C_{SLOPE}} \quad (\text{V/s})$$

$$C_{SLOPE} = 4\text{pF}$$

Figure 4 shows the block diagram of the phase current sense and the ramp generator, and the idealized waveforms.



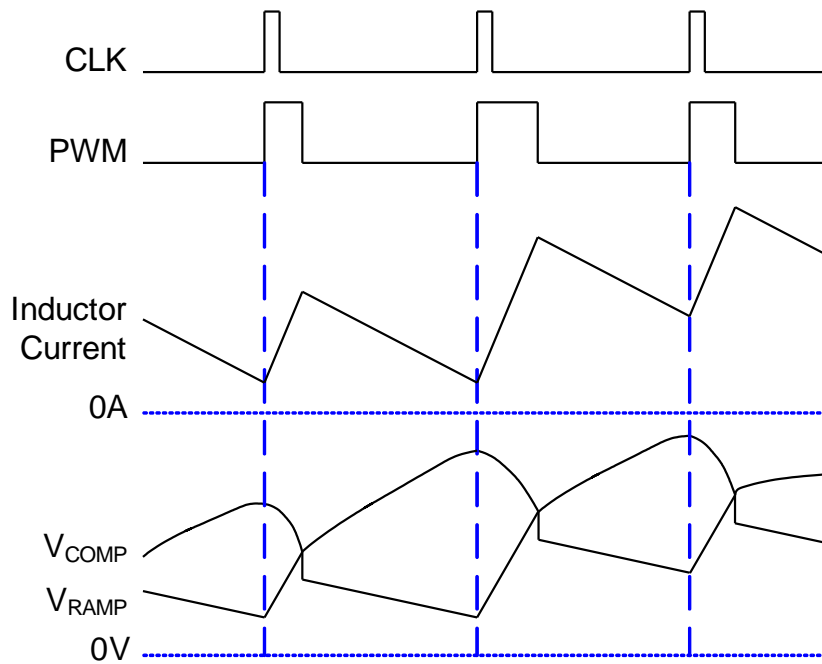
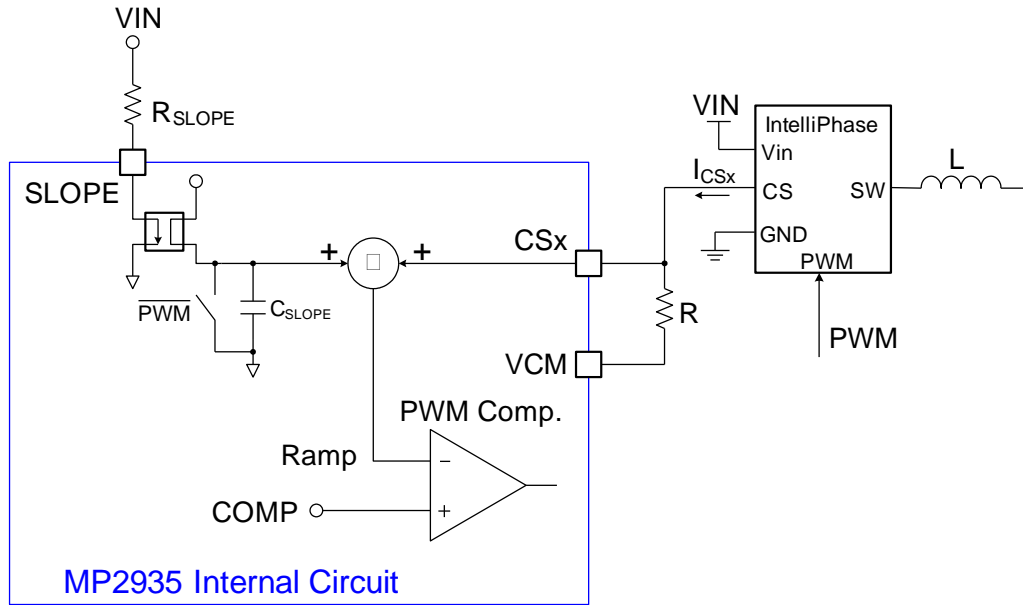

Figure 4: Block Diagram of Phase Current Sense and Ramp Generator

External resistors,  $R$ , from the CSx pin to the VCM reference pin can convert the  $I_{CS}$  current to a related voltage. To increase the current in any given phase, reduce the  $R$  for that phase. Upon reaching the current limit, MP2935 switches to full phase PWM mode regardless of power state status to avoid inrush current stress to the phase 1 power stage.

### Voltage Regulation

Output voltage remote sensing is available. Remote sensing allows the voltage regulator to compensate for various resistive drops in the power path and ensure that the voltage seen at the CPU die is the correct level independent of the load current. The VOSEN and GNDSSEN pins connect to the Kelvin sense leads at the die of the processor through the processor socket as the signals VCC\_SENSE and VSS\_SENSE, respectively. This allows the voltage regulator to tightly control the processor voltage at the die, independent of layout inconsistencies and drops. This Kelvin sense technique provides extremely tight load line regulation. Treat these traces as noise-sensitive. For optimal load-line regulation performance, lay out the traces connecting these

two pins to the Kelvin sense leads of the processor in parallel and away from rapidly-rising voltage nodes (switching nodes) and other noisy traces. To achieve optimal performance, place common mode and differential mode RC filters to analog ground on VOSEN and GNDSSEN. Keep the filter resistors on the order of  $10\Omega$  so that they do not interact with the  $50k\Omega$  input resistance of the differential amplifier.

The voltage-mode control loop consists of a high-gain-bandwidth error amplifier. The 8-bit VID DAC sets the non-inverting input voltage. The VID codes are listed in Table 2. The output of the error amplifier goes to the COMP pin, which sets the termination voltage for the internal PWM ramps. The inverting input, FB, connects to the output of the remote sense amplifier through a resistor,  $R_{FB}$ , to sense and control the output voltage at the remote sense point.  $R_{FB}$  generates the droop voltage as a function of the load current—commonly known as active voltage positioning—by injecting the droop current,  $I_{DRP}$ , into the FB pin. The main loop compensation is incorporated into the feedback network connected between the FB and COMP pins.

**Table 2: SVID Code Table**

DEC	VID7	VID6	VID5	VID4	VID3	VID2	VID1	VID0	HEX	V <sub>OUT</sub>
0	0	0	0	0	0	0	0	0	00	OFF
1	0	0	0	0	0	0	0	1	01	0.500
2	0	0	0	0	0	0	1	0	02	0.510
3	0	0	0	0	0	0	1	1	03	0.520
4	0	0	0	0	0	1	0	0	04	0.530
5	0	0	0	0	0	1	0	1	05	0.540
6	0	0	0	0	0	1	1	0	06	0.550
7	0	0	0	0	0	1	1	1	07	0.560
8	0	0	0	0	1	0	0	0	08	0.570
9	0	0	0	0	1	0	0	1	09	0.580
10	0	0	0	0	1	0	1	0	0A	0.590
11	0	0	0	0	1	0	1	1	0B	0.600
12	0	0	0	0	1	1	0	0	0C	0.610
13	0	0	0	0	1	1	0	1	0D	0.620
14	0	0	0	0	1	1	1	0	0E	0.630
15	0	0	0	0	1	1	1	1	0F	0.640
16	0	0	0	1	0	0	0	0	10	0.650
17	0	0	0	1	0	0	0	1	11	0.660
18	0	0	0	1	0	0	1	0	12	0.670
19	0	0	0	1	0	0	1	1	13	0.680
20	0	0	0	1	0	1	0	0	14	0.690
21	0	0	0	1	0	1	0	1	15	0.700
22	0	0	0	1	0	1	1	0	16	0.710
23	0	0	0	1	0	1	1	1	17	0.720
24	0	0	0	1	1	0	0	0	18	0.730
25	0	0	0	1	1	0	0	1	19	0.740
26	0	0	0	1	1	0	1	0	1A	0.750
27	0	0	0	1	1	0	1	1	1B	0.760
28	0	0	0	1	1	1	0	0	1C	0.770
29	0	0	0	1	1	1	0	1	1D	0.780
30	0	0	0	1	1	1	1	0	1E	0.790
31	0	0	0	1	1	1	1	1	1F	0.800
32	0	0	1	0	0	0	0	0	20	0.810
33	0	0	1	0	0	0	0	1	21	0.820
34	0	0	1	0	0	0	1	0	22	0.830
35	0	0	1	0	0	0	1	1	23	0.840
36	0	0	1	0	0	1	0	0	24	0.850
37	0	0	1	0	0	1	0	1	25	0.860
38	0	0	1	0	0	1	1	0	26	0.870
39	0	0	1	0	0	1	1	1	27	0.880
40	0	0	1	0	1	0	0	0	28	0.890
41	0	0	1	0	1	0	0	1	29	0.900
42	0	0	1	0	1	0	1	0	2A	0.910
43	0	0	1	0	1	0	1	1	2B	0.920
44	0	0	1	0	1	1	0	0	2C	0.930
45	0	0	1	0	1	1	0	1	2D	0.940
46	0	0	1	0	1	1	1	0	2E	0.950
47	0	0	1	0	1	1	1	1	2F	0.960
48	0	0	1	1	0	0	0	0	30	0.970

DEC	VID7	VID6	VID5	VID4	VID3	VID2	VID1	VID0	HEX	V <sub>OUT</sub>
49	0	0	1	1	0	0	0	1	31	0.980
50	0	0	1	1	0	0	1	0	32	0.990
51	0	0	1	1	0	0	1	1	33	1.000
52	0	0	1	1	0	1	0	0	34	1.010
53	0	0	1	1	0	1	0	1	35	1.020
54	0	0	1	1	0	1	1	0	36	1.030
55	0	0	1	1	0	1	1	1	37	1.040
56	0	0	1	1	1	0	0	0	38	1.050
57	0	0	1	1	1	0	0	1	39	1.060
58	0	0	1	1	1	0	1	0	3A	1.070
59	0	0	1	1	1	0	1	1	3B	1.080
60	0	0	1	1	1	1	0	0	3C	1.090
61	0	0	1	1	1	1	0	1	3D	1.100
62	0	0	1	1	1	1	1	0	3E	1.110
63	0	0	1	1	1	1	1	1	3F	1.120
64	0	1	0	0	0	0	0	0	40	1.130
65	0	1	0	0	0	0	0	1	41	1.140
66	0	1	0	0	0	0	1	0	42	1.150
67	0	1	0	0	0	0	1	1	43	1.160
68	0	1	0	0	0	1	0	0	44	1.170
69	0	1	0	0	0	1	0	1	45	1.180
70	0	1	0	0	0	1	1	0	46	1.190
71	0	1	0	0	0	1	1	1	47	1.200
72	0	1	0	0	1	0	0	0	48	1.210
73	0	1	0	0	1	0	0	1	49	1.220
74	0	1	0	0	1	0	1	0	4A	1.230
75	0	1	0	0	1	0	1	1	4B	1.240
76	0	1	0	0	1	1	0	0	4C	1.250
77	0	1	0	0	1	1	0	1	4D	1.260
78	0	1	0	0	1	1	1	0	4E	1.270
79	0	1	0	0	1	1	1	1	4F	1.280
80	0	1	0	1	0	0	0	0	50	1.290
81	0	1	0	1	0	0	0	1	51	1.300
82	0	1	0	1	0	0	1	0	52	1.310
83	0	1	0	1	0	0	1	1	53	1.320
84	0	1	0	1	0	1	0	0	54	1.330
85	0	1	0	1	0	1	0	1	55	1.340
86	0	1	0	1	0	1	1	0	56	1.350
87	0	1	0	1	0	1	1	1	57	1.360
88	0	1	0	1	1	0	0	0	58	1.370
89	0	1	0	1	1	0	0	1	59	1.380
90	0	1	0	1	1	0	1	0	5A	1.390
91	0	1	0	1	1	0	1	1	5B	1.400
92	0	1	0	1	1	1	0	0	5C	1.410
93	0	1	0	1	1	1	0	1	5D	1.420
94	0	1	0	1	1	1	1	0	5E	1.430
95	0	1	0	1	1	1	1	1	5F	1.440
96	0	1	1	0	0	0	0	0	60	1.450

DEC	VID7	VID6	VID5	VID4	VID3	VID2	VID1	VID0	HEX	V <sub>OUT</sub>
97	0	1	1	0	0	0	0	1	61	1.460
98	0	1	1	0	0	0	1	0	62	1.470
99	0	1	1	0	0	0	1	1	63	1.480
100	0	1	1	0	0	1	0	0	64	1.490
101	0	1	1	0	0	1	0	1	65	1.500
102	0	1	1	0	0	1	1	0	66	1.510
103	0	1	1	0	0	1	1	1	67	1.520
104	0	1	1	0	1	0	0	0	68	1.530
105	0	1	1	0	1	0	0	1	69	1.540
106	0	1	1	0	1	0	1	0	6A	1.550
107	0	1	1	0	1	0	1	1	6B	1.560
108	0	1	1	0	1	1	0	0	6C	1.570
109	0	1	1	0	1	1	0	1	6D	1.580
110	0	1	1	0	1	1	1	0	6E	1.590
111	0	1	1	0	1	1	1	1	6F	1.600
112	0	1	1	1	0	0	0	0	70	1.610
113	0	1	1	1	0	0	0	1	71	1.620
114	0	1	1	1	0	0	1	0	72	1.630
115	0	1	1	1	0	0	1	1	73	1.640
116	0	1	1	1	0	1	0	0	74	1.650
117	0	1	1	1	0	1	0	1	75	1.660
118	0	1	1	1	0	1	1	0	76	1.670
119	0	1	1	1	0	1	1	1	77	1.680
120	0	1	1	1	1	0	0	0	78	1.690
121	0	1	1	1	1	0	0	1	79	1.700
122	0	1	1	1	1	0	1	0	7A	1.710
123	0	1	1	1	1	0	1	1	7B	1.720
124	0	1	1	1	1	1	0	0	7C	1.730
125	0	1	1	1	1	1	0	1	7D	1.740
126	0	1	1	1	1	1	1	0	7E	1.750
127	0	1	1	1	1	1	1	1	7F	1.760
128	1	0	0	0	0	0	0	0	80	1.770
129	1	0	0	0	0	0	0	1	81	1.780
130	1	0	0	0	0	0	1	0	82	1.790
131	1	0	0	0	0	0	1	1	83	1.800
132	1	0	0	0	0	1	0	0	84	1.810
133	1	0	0	0	0	1	0	1	85	1.820
134	1	0	0	0	0	1	1	0	86	1.830
135	1	0	0	0	0	1	1	1	87	1.840
136	1	0	0	0	1	0	0	0	88	1.850
137	1	0	0	0	1	0	0	1	89	1.860
138	1	0	0	0	1	0	1	0	8A	1.870
139	1	0	0	0	1	0	1	1	8B	1.880
140	1	0	0	0	1	1	0	0	8C	1.890
141	1	0	0	0	1	1	0	1	8D	1.900
142	1	0	0	0	1	1	1	0	8E	1.910
143	1	0	0	0	1	1	1	1	8F	1.920
144	1	0	0	1	0	0	0	0	90	1.930

DEC	VID7	VID6	VID5	VID4	VID3	VID2	VID1	VID0	HEX	V <sub>OUT</sub>
145	1	0	0	1	0	0	0	1	91	1.940
146	1	0	0	1	0	0	1	0	92	1.950
147	1	0	0	1	0	0	1	1	93	1.960
148	1	0	0	1	0	1	0	0	94	1.970
149	1	0	0	1	0	1	0	1	95	1.980
150	1	0	0	1	0	1	1	0	96	1.990
151	1	0	0	1	0	1	1	1	97	2.000
152	1	0	0	1	1	0	0	0	98	2.010
153	1	0	0	1	1	0	0	1	99	2.020
154	1	0	0	1	1	0	1	0	9A	2.030
155	1	0	0	1	1	0	1	1	9B	2.040
156	1	0	0	1	1	1	0	0	9C	2.050
157	1	0	0	1	1	1	0	1	9D	2.060
158	1	0	0	1	1	1	1	0	9E	2.070
159	1	0	0	1	1	1	1	1	9F	2.080
160	1	0	1	0	0	0	0	0	A0	2.090
161	1	0	1	0	0	0	0	1	A1	2.100
162	1	0	1	0	0	0	1	0	A2	2.110
163	1	0	1	0	0	0	1	1	A3	2.120
164	1	0	1	0	0	1	0	0	A4	2.130
165	1	0	1	0	0	1	0	1	A5	2.140
166	1	0	1	0	0	1	1	0	A6	2.150
167	1	0	1	0	0	1	1	1	A7	2.160
168	1	0	1	0	1	0	0	0	A8	2.170
169	1	0	1	0	1	0	0	1	A9	2.180
170	1	0	1	0	1	0	1	0	AA	2.190
171	1	0	1	0	1	0	1	1	AB	2.200
172	1	0	1	0	1	1	0	0	AC	2.210
173	1	0	1	0	1	1	0	1	AD	2.220
174	1	0	1	0	1	1	1	0	AE	2.230
175	1	0	1	0	1	1	1	1	AF	2.240
176	1	0	1	1	0	0	0	0	B0	2.250
177	1	0	1	1	0	0	0	1	B1	2.260
178	1	0	1	1	0	0	1	0	B2	2.270
179	1	0	1	1	0	0	1	1	B3	2.280
180	1	0	1	1	0	1	0	0	B4	2.290
181	1	0	1	1	0	1	0	1	B5	2.300
182	1	0	1	1	0	1	1	0	B6	2.310
183	1	0	1	1	0	1	1	1	B7	2.320
184	1	0	1	1	1	0	0	0	B8	2.330
185	1	0	1	1	1	0	0	1	B9	2.340
186	1	0	1	1	1	0	1	0	BA	2.350
187	1	0	1	1	1	0	1	1	BB	2.360
188	1	0	1	1	1	1	0	0	BC	2.370
189	1	0	1	1	1	1	0	1	BD	2.380
190	1	0	1	1	1	1	1	0	BE	2.390
191	1	0	1	1	1	1	1	1	BF	2.400
192	1	1	0	0	0	0	0	0	C0	2.410

DEC	VID7	VID6	VID5	VID4	VID3	VID2	VID1	VID0	HEX	V <sub>OUT</sub>
193	1	1	0	0	0	0	0	1	C1	2.420
194	1	1	0	0	0	0	1	0	C2	2.430
195	1	1	0	0	0	0	1	1	C3	2.440
196	1	1	0	0	0	1	0	0	C4	2.450
197	1	1	0	0	0	1	0	1	C5	2.460
198	1	1	0	0	0	1	1	0	C6	2.470
199	1	1	0	0	0	1	1	1	C7	2.480
200	1	1	0	0	1	0	0	0	C8	2.490
201	1	1	0	0	1	0	0	1	C9	2.500
202	1	1	0	0	1	0	1	0	CA	2.510
203	1	1	0	0	1	0	1	1	CB	2.520
204	1	1	0	0	1	1	0	0	CC	2.530
205	1	1	0	0	1	1	0	1	CD	2.540
206	1	1	0	0	1	1	1	0	CE	2.550
207	1	1	0	0	1	1	1	1	CF	2.560
208	1	1	0	1	0	0	0	0	D0	2.570
209	1	1	0	1	0	0	0	1	D1	2.580
210	1	1	0	1	0	0	1	0	D2	2.590
211	1	1	0	1	0	0	1	1	D3	2.600
212	1	1	0	1	0	1	0	0	D4	2.610
213	1	1	0	1	0	1	0	1	D5	2.620
214	1	1	0	1	0	1	1	0	D6	2.630
215	1	1	0	1	0	1	1	1	D7	2.640
216	1	1	0	1	1	0	0	0	D8	2.650
217	1	1	0	1	1	0	0	1	D9	2.660
218	1	1	0	1	1	0	1	0	DA	2.670
219	1	1	0	1	1	0	1	1	DB	2.680
220	1	1	0	1	1	1	0	0	DC	2.690
221	1	1	0	1	1	1	0	1	DD	2.700
222	1	1	0	1	1	1	1	0	DE	2.710
223	1	1	0	1	1	1	1	1	DF	2.720
224	1	1	1	0	0	0	0	0	E0	2.730
225	1	1	1	0	0	0	0	1	E1	2.740
226	1	1	1	0	0	0	1	0	E2	2.750
227	1	1	1	0	0	0	1	1	E3	2.760
228	1	1	1	0	0	1	0	0	E4	2.770
229	1	1	1	0	0	1	0	1	E5	2.780
230	1	1	1	0	0	1	1	0	E6	2.790
231	1	1	1	0	0	1	1	1	E7	2.800
232	1	1	1	0	1	0	0	0	E8	2.810
233	1	1	1	0	1	0	0	1	E9	2.820
234	1	1	1	0	1	0	1	0	EA	2.830
235	1	1	1	0	1	0	1	1	EB	2.840
236	1	1	1	0	1	1	0	0	EC	2.850
237	1	1	1	0	1	1	0	1	ED	2.860
238	1	1	1	0	1	1	1	0	EE	2.870
239	1	1	1	0	1	1	1	1	EF	2.880
240	1	1	1	1	0	0	0	0	F0	2.890

DEC	VID7	VID6	VID5	VID4	VID3	VID2	VID1	VID0	HEX	V <sub>OUT</sub>
241	1	1	1	1	0	0	0	1	F1	2.900
242	1	1	1	1	0	0	1	0	F2	2.910
243	1	1	1	1	0	0	1	1	F3	2.920
244	1	1	1	1	0	1	0	0	F4	2.930
245	1	1	1	1	0	1	0	1	F5	2.940
246	1	1	1	1	0	1	1	0	F6	2.950
247	1	1	1	1	0	1	1	1	F7	2.960
248	1	1	1	1	1	0	0	0	F8	2.970
249	1	1	1	1	1	0	0	1	F9	2.980
250	1	1	1	1	1	0	1	0	FA	2.990
251	1	1	1	1	1	0	1	1	FB	3.000
252	1	1	1	1	1	1	0	0	FC	3.010
253	1	1	1	1	1	1	0	1	FD	3.020
254	1	1	1	1	1	1	1	0	FE	3.030
255	1	1	1	1	1	1	1	1	FF	3.040

### Load-line Regulation

The droop, known as Adaptive Voltage Positioning (AVP), on MP2935 can be generated by injecting the I<sub>DRP</sub> current to the feedback resistor.

The current output on the IDROOP pin is  $\frac{1}{16}$  of the I<sub>VCM</sub> current, which is proportional to the

total output current. Selecting the proper R<sub>FB1</sub> value can achieve the desired load-line. In the case of zero droop, floats the IDROOP pin. Figure 5 shows the block diagram of droop generation.

$$R_{FB1} = 16 \times 10^5 \times \text{Droop}$$

For 1mΩ droop, R<sub>FB1</sub>=1.6KΩ.

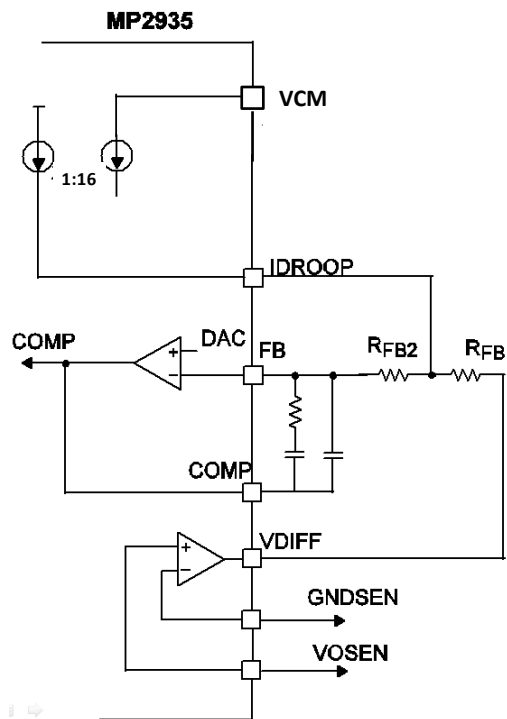

**Figure 5: Block Diagram of Droop Generator**



### Output Voltage Offset Programming

After receiving the SVID command for setting the offset (33h), the SVID controller compares the VID plus the proposed offset with the maximum VID of FFh (3.04V), and rejects the SVID command if this value exceeds FFh. If the VID plus proposed offset is less than FFh, the SVID updates the register 33h and the DAC ramps up/down to the new value of VID+Offset with slow slew rate defined in register 25h. During ramp up/down to the new DAC value, the SVID rejects all SVID commands, which is the same behavior as SetVID\_Fast/Slow.

### Dynamic VID

The SVID bus sends out new target voltage and slew rate commands to the PWM IC. The VR responds by slewing to the new voltage in a controlled manner without falsely tripping VRRDY, over-voltage, or over-current protection circuits. To meet all market segment requirements, there are three different slew rates: fast, slow, and decay. During fast and slow VID transitions, the SVID controller ramps up/down the VID code step-by-step. There is a 4MHz ID clock for VID change, with defined VID step of 10mV, the maximum slew rate is up to 20mV/ $\mu$ s.

During VID decay, the VR output voltage converges to the new VID target, but does not control the slew rate; the output voltage decays at a rate proportional to the load current.

The VID change triggers a VR\_RDY masking timer to prevent a VR\_RDY failure. Each VID change resets and restarts the internal VR\_RDY masking timer. During the VID transition except VID decay, MP2935 forces a full-phase PWM operation and reset the power state to PS0 by default.

### SetVID\_Fast/Slow

If the VR is in a low-power state and receives a new SetVID\_Fast/Slow command, then the VR exits the low-power state to normal mode (PS0), operating in full-phase PWM mode to move the voltage by the preset slew rate. The VR remains in PS0, until it receives a new power state command.

### SetVID\_Decay

In the case of a SetVID\_Decay command, the VR automatically goes to PS2 or remain at PS3. SetVID\_Decay command steps up the VID DAC to the target VID at 10mV/step, with each step triggered by VR\_SETTLE assert. In the event of a SetPS command during the  $V_{OUT}$  decay, MP2935 will enter into the requested power state after  $V_{OUT}$  reaches the requested VID value. Whenever the VR exits decay mode whenever it receives a SetVID\_Fast/Slow, enters PS0 power state, and ramps up/down to the new VID from its current VID.

Figure 6 shows the detailed diagram of the operation modes with the VID Transition taken into consideration.

Figure 7(a) to 7(d) show the detailed signals of Decay mode operation for different cases.

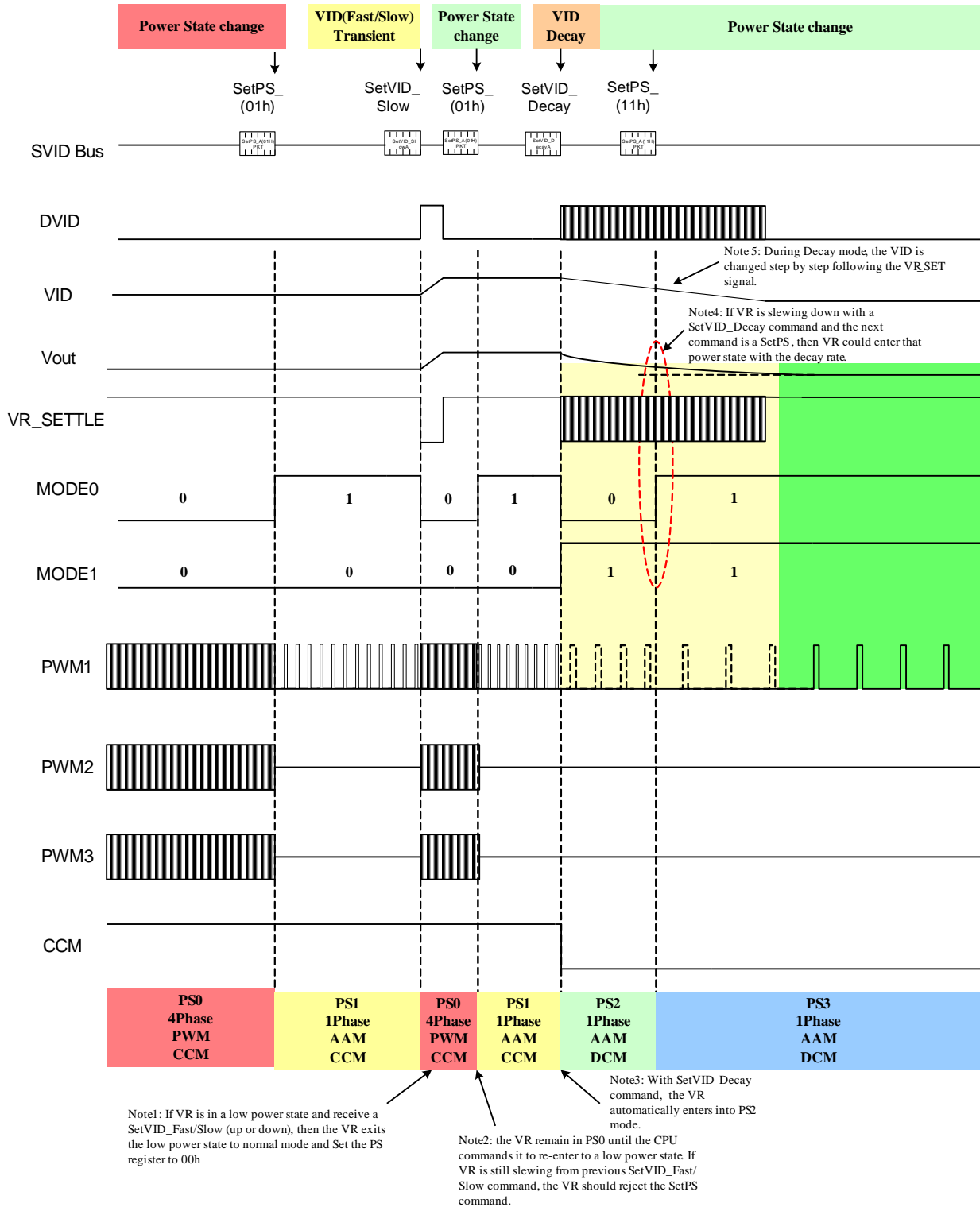
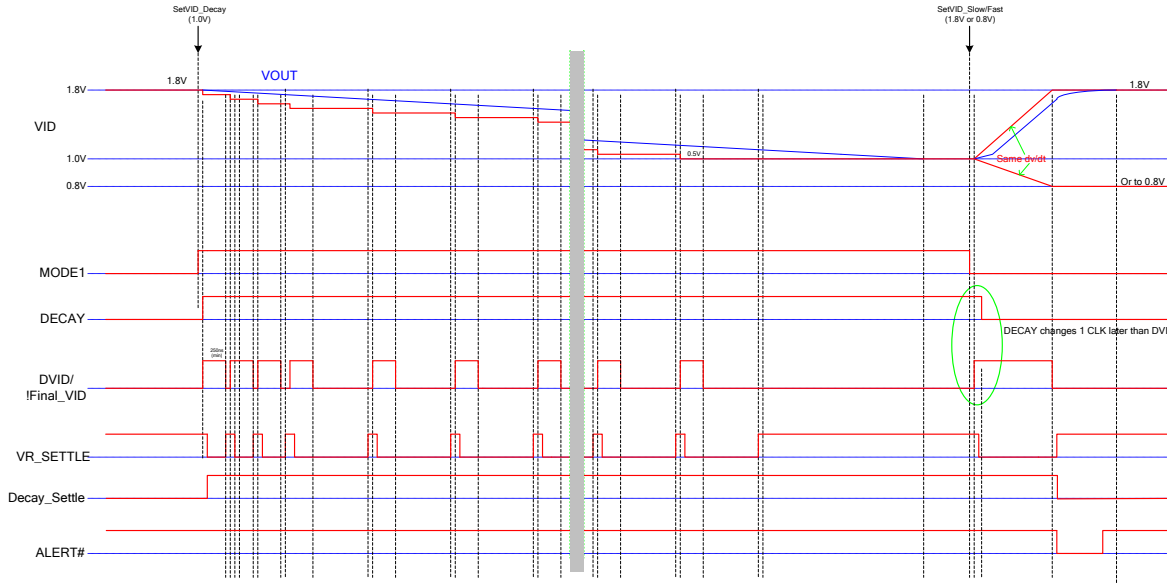
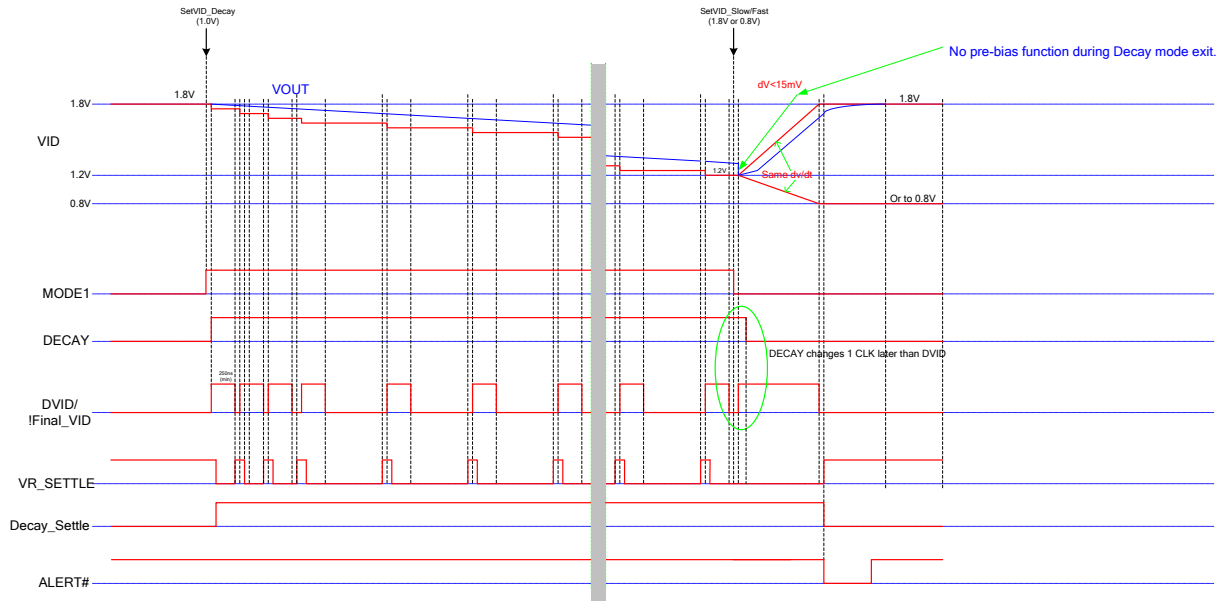

Figure 6: Detailed Diagram of the Operation Modes



Case 1. CPU commands VID 1.8V decay to 1.0V. (SetVID\_Decay 1.0V)  
At the time of VOUT reaches 1.0V target, SetVID\_Fast/Slow to either 1.8V or 0.8V.

Figure 7(a)



Case 2. CPU commands VID 1.8V decay to 1.0V.  
Before the VOUT reaches 1.0V target, the new command of SetVID\_Fast/Slow sets new target of either 1.8V or 0.8V.

Figure 7(b)

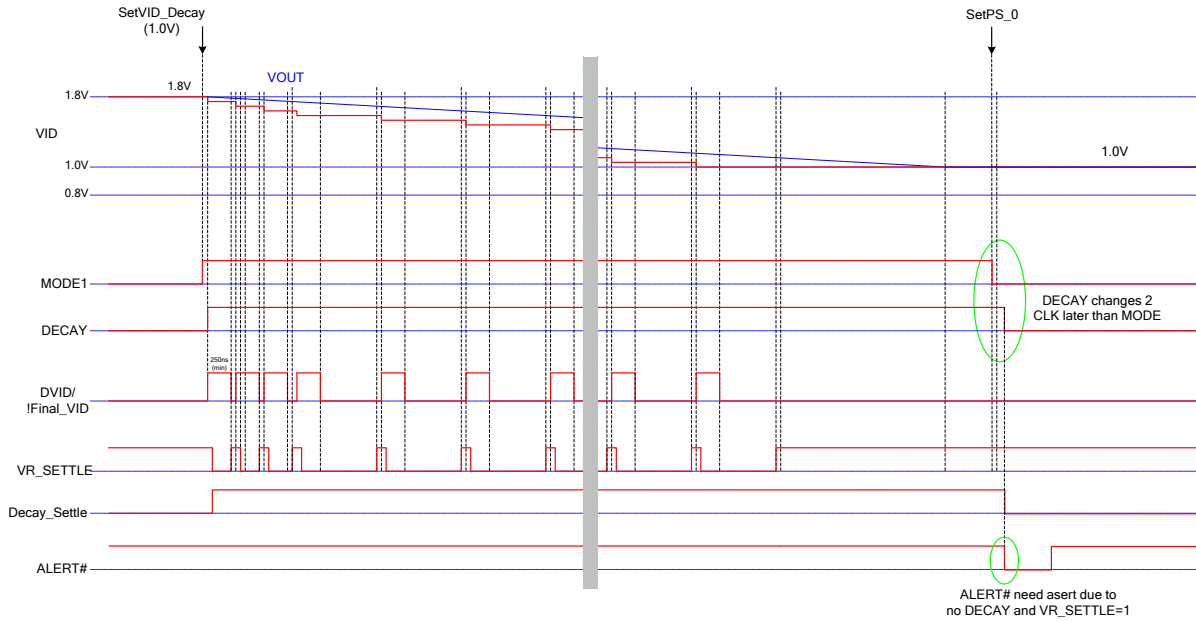

Case 3. CPU commands VID 1.8V decay to 1.0V.  
After VOUT reaches 1.0V target, Set the Power Stage to PS0, SetPS(0) command.

Figure 7(c)

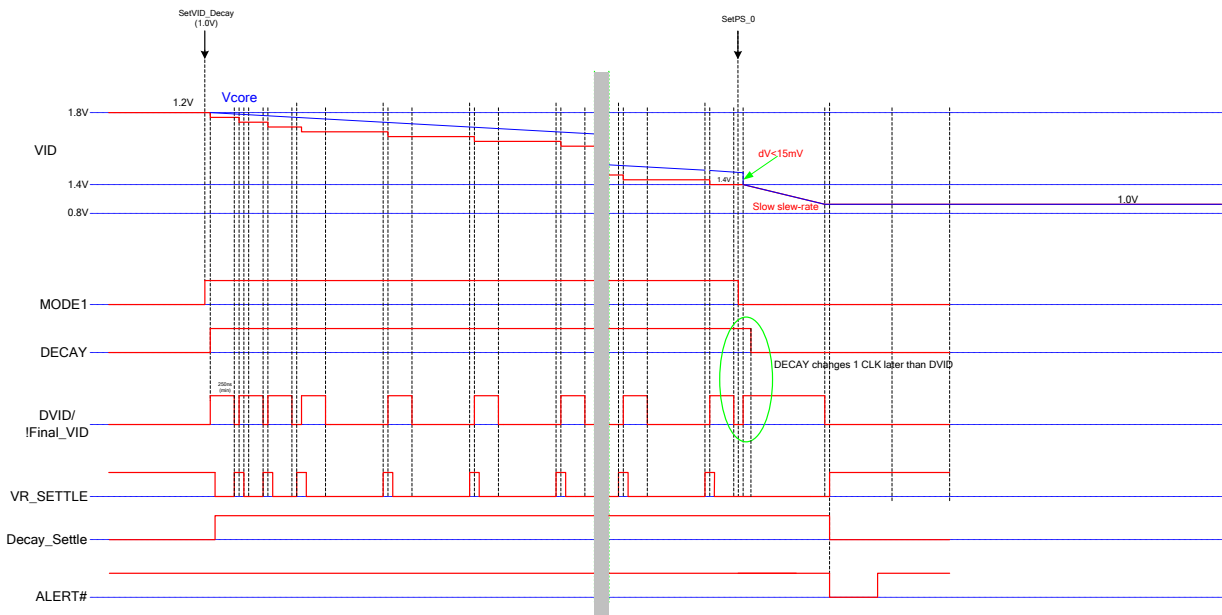

Case 4. CPU commands VID 1.8V decay to 1.0V.  
Before VOUT reaches 1.0V target, Set the Power Stage to PS0, SetPS(0) command.

Figure 7(d)

Figure 7: Detail Signal during Decay Mode Operation

### Enable and Disable

To enable MP2935, the VCC supply voltage must exceed the UVLO upper threshold and the EN pin must exceed its logic-high threshold. After start-up, VDD (3.3V) supplies the SVID controller and interface. Whenever the VCC voltage is less than the UVLO threshold or the EN pin is logic low, MP2935 shuts down, and the controller sets all PWM outputs to a high-impedance (Hi-Z) state.

### Soft-start and Start-up into Pre-biased Output

After enabling MP2935, the VR can start-up. The DAC ramps up to the  $V_{BOOT}$  voltage with the slew rate set in SR\_Slow register. During soft-start, the PWM is in Hi-Z state until the DAC reaches FB voltage preventing the pre-biased output from discharging. Upon completion of soft-start, VR\_RDY asserts if there are no faults during a typical 2ms delay.

Set VBOOT voltage by using two resistors to form a resistor divider from VDD to set the VBOOT pin voltage. VDD pin is the internal 3.3V LDO output. Table 3 shows the resistor pairs for different VBOOT voltages.

**Table 3:  $V_{BOOT}$  Setting Resistance**

$V_{BOOT}$ Voltage	$R_{VBOOT\_GND}$	$R_{VDD\_VBOOT}$
1.85V	768 $\Omega$	47.5k $\Omega$
1.8V	768 $\Omega$	19.6k $\Omega$
1.75V	768 $\Omega$	12.1k $\Omega$
1.7V	768 $\Omega$	8.45k $\Omega$
1.65V	768 $\Omega$	6.34k $\Omega$
1.6V	768 $\Omega$	5.11k $\Omega$
1.5V	768 $\Omega$	4.22k $\Omega$
1.35V	768 $\Omega$	3.48k $\Omega$
1.25V	768 $\Omega$	3.01k $\Omega$
1.2V	768 $\Omega$	2.55k $\Omega$
1.1V	768 $\Omega$	2.21k $\Omega$
1V	768 $\Omega$	2k $\Omega$
0.9V	768 $\Omega$	1.78k $\Omega$
0V	768 $\Omega$	1.58k $\Omega$
0.6V	768 $\Omega$	1.43k $\Omega$
0.8V	768 $\Omega$	1.27k $\Omega$

### VR\_Settle Monitoring

VR\_SETTLE signal indicates whether the dynamic VID (DVID) transition has completed.

VR\_SETTLE is de-asserted when the VR controller receives a new VID code different from the previous one; VR\_SETTLE is asserted again when the output voltage is within 10 mV or one VID step of the target voltage.

The falling edge of DVID indicates that the VID ramping will complete soon. When the SVID controller receives a new VID target from the SVID master, it asserts the DVID signal; then the SVID controller ramps up/down the VID code step-wise to the target VID. The SVID controller de-asserts DVID when the current VID code is within 10mV or one VID step of targeted voltage. Then the sensed output voltage is compared to the DAC output to determine VRSETTLE signal when the DVID is asserted. Once DVID is asserted, it lasts for at least 250ns.

The only condition that asserts and de-asserts VR\_SETTLE is the VID transition. VRSETTLE remains unchanged even if the output voltage exits the  $\pm 10\text{mV}$  window when operating under a stable VID code.

When the VID change is within 1 step, the SVID controller de-asserts the DVID signal for a minimum of 500ns and VRSETTLE resets. VR\_SETTLE sets if the output is within  $\pm 10\text{mV}$  after DVID is asserted. The SVID responds with ALERT# after the ACK signal from the CPU if VR\_SETTLE is asserted.

### Fault Monitoring and Protections

The fault monitoring and protections provided by MP2935 are listed below.

- 1) VR\_RDY signals
- 2) Under-voltage monitor and protection
- 3) Over-voltage monitor and protection
- 4) Reverse-voltage monitor and protection
- 5) Over-current monitor and protection
- 6) Thermal monitors and over-temperature indicator (VR\_HOT#, active low)
- 7) FAULT# (active low) signal

### VR\_Rdy Signal

VRRDY pin is an active-high (open drain) output that indicates that the start-up sequence has completed and that the output voltage has moved to the  $V_{BOOT}$  value or the SVID programmed VID value. This signal is part of the start-up sequence for other voltage regulators, the clock, microprocessor reset, etc. VRRDY comparator monitors the operation of VR through the fault latch logic. The signal remains asserted during normal operation and de-asserts whenever a fault (OCP, OVP, etc.) or shutdown conditions occurred. This signal does not represent DC output accuracy through its VID value and does not track VID during dynamic VID events. VRRDY indicates that the VR is operating properly, not falsely trigger during dynamic VID transitions.

VRReady\_0V flat is under register 34h configures multiple slaves (VRs) on the same bus on the server platforms. It is also used in notebook and desktop systems to program VRRDY operation when the VID command is set to 0V or off condition.

If “VR\_RDY\_0V” =0 (default, normal mode), then VR\_RDY de-asserts if the VR is given a SetVID (0.0V) command, i.e., the VR is off.

If “VR\_RDY\_0V”=1, then VRRDY does not de-assert when a SetVID (0.0V) command is issued. This means that the 0V output is a valid voltage setting and the VR is ready to accept the next command. Under this definition, VR\_RDY only de-asserts at power-down or under fault conditions.

See Figure 8 for more details.

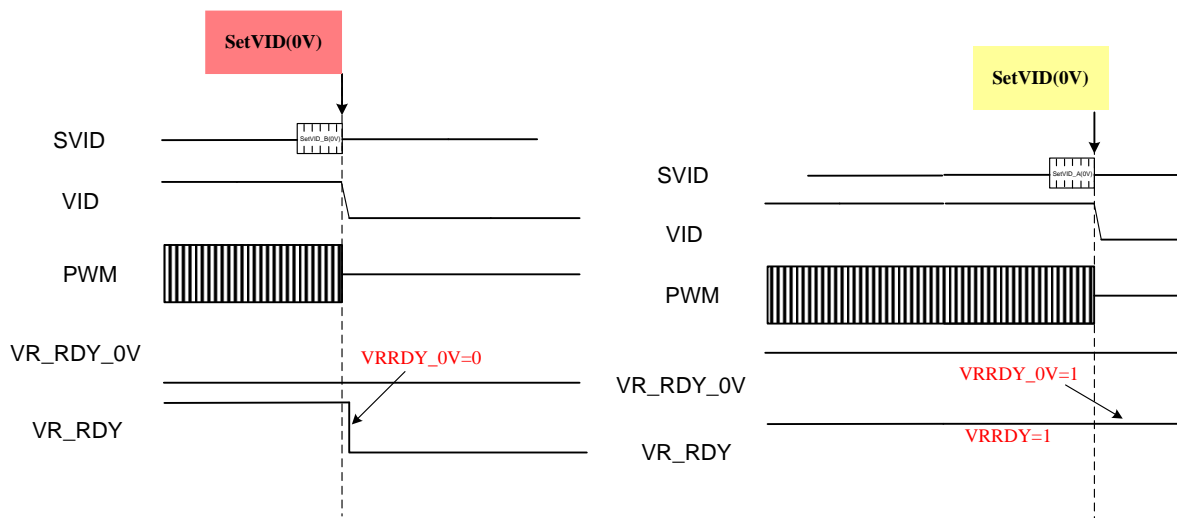

**Figure 8: VR\_RDY\_0V Operation Waveforms**

### Under-voltage Detection

Under-voltage protection is independent of the over-current limit. A fault triggers if the output voltage is less than the VID value by 300mV or more for at least 1ms. Then the VR shuts off and latches and VR\_RDY goes low. Note that most practical voltage regulators will trigger over-current before dropping below the -300mV under-voltage limit. Refer to Figure 9.

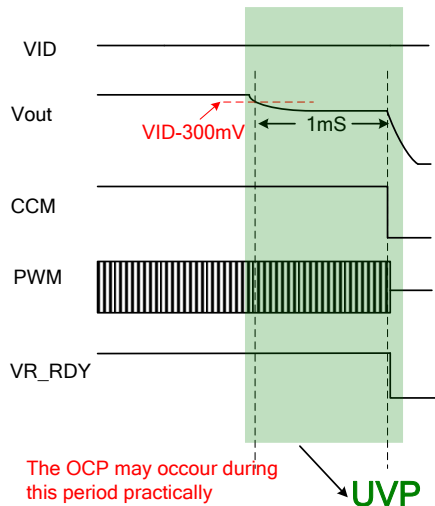

**Figure 9: Under-Voltage Protection**

### Over-voltage Protection

OVP circuit monitors the output for an over-voltage condition.

There are two levels of over-voltage protection: OVP1 is the first level of over-voltage protection, and is defined as VID+400mV; OVP 2 is set at 3.40V. Once the output voltage exceeds either of these two OVP levels, an over-voltage (OV) fault will trigger immediately.

The first level OV detector (VID+400mV) is blanked until the first falling edge of the DVID signal after the part is enabled. This prevents the false latch with start-up with pre-biased output voltage.

OVP1 monitor is also disabled during the VID decay transition. It re-activates after finishing VR\_SETTLE re-assertion transition.

During fast or slow VID transitions, the OVP1 is blanked for 100µs. Figure 10 summarizes the blanking conditions for the OVP1 monitor.

The OVP2 monitor is active at all times when the controller is enabled regardless of fault conditions. This ensures that the load is protected against high-side MOSFET leakage while the MOSFETs turn off.

In the event of an OVP condition, the PWMs are latched low with CCM=1 to turn off the high-side MOSFETs and turn on low-side MOSFETs to crowbar the output, while VRRDY de-asserts. The OVP latch can only reset when toggled enable, toggles the VCC, or when reverse-voltage protection (RVP) occurs.

Figure 10 shows the OVP fault latch for the two levels.

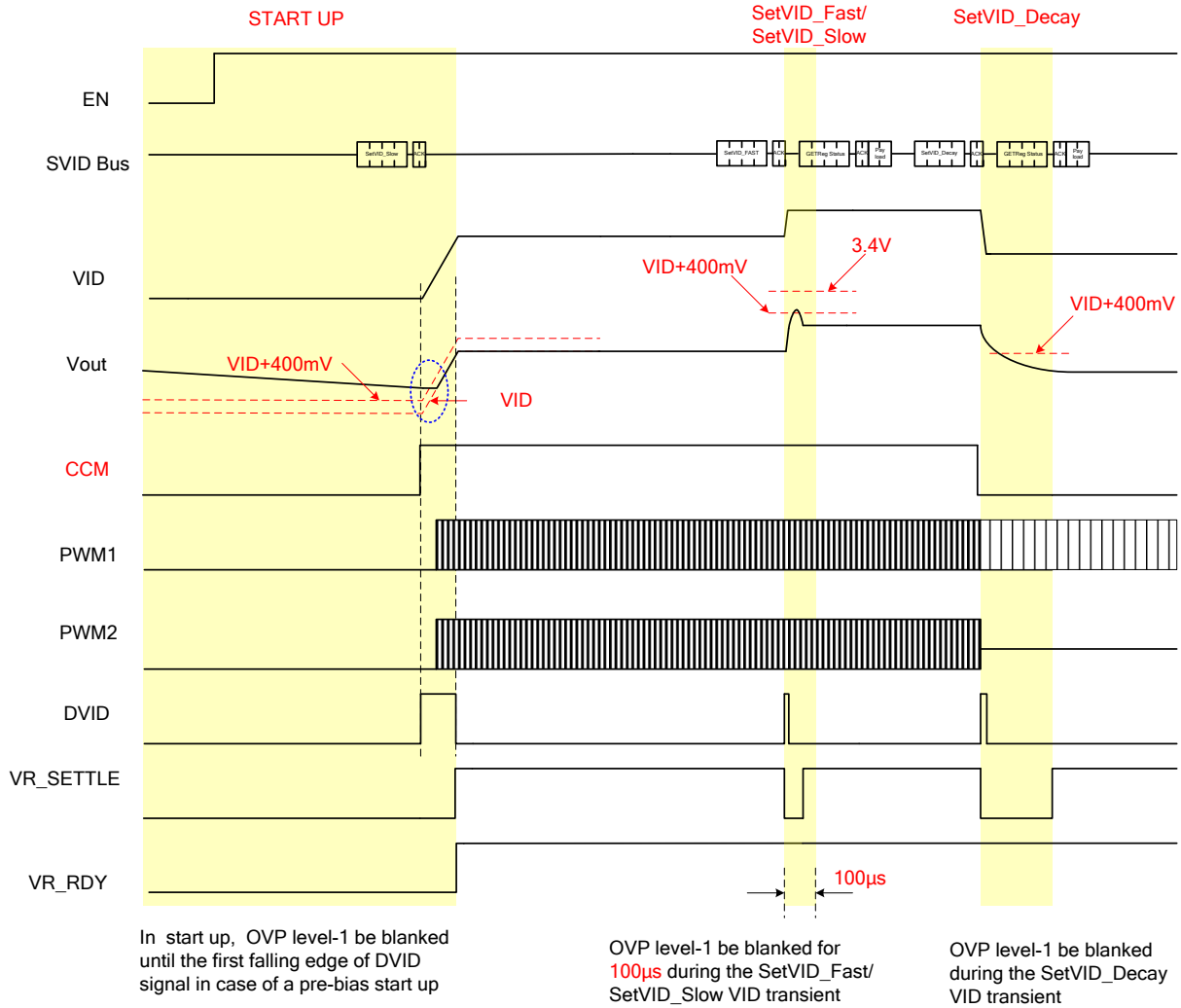
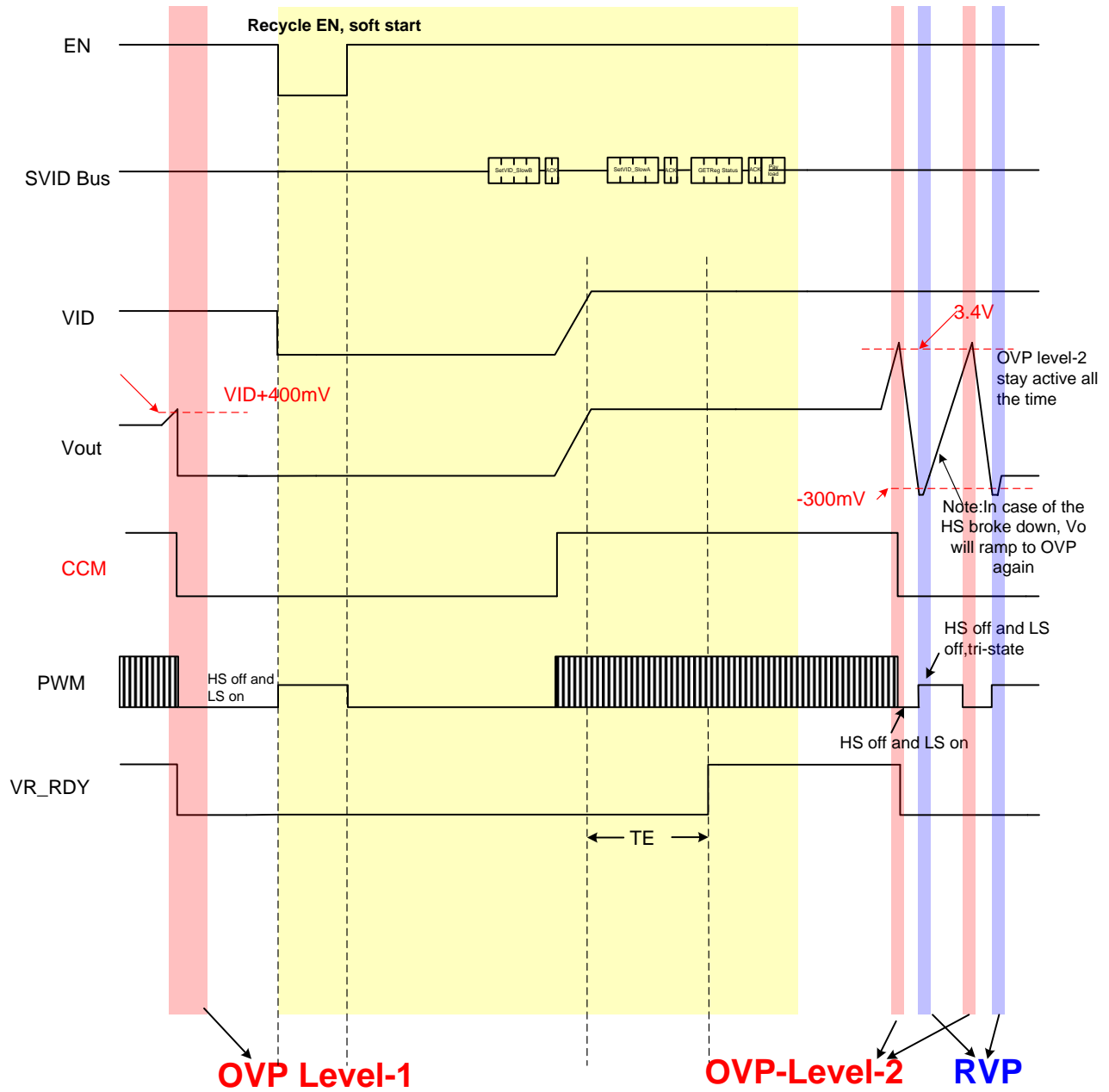

Figure 10: OVP Protection Blanking Conditions





**Figure 11: OVP and RVP Fault Protection**

### Reverse-voltage Detection

Very large reverse inductor currents cause negative output voltages that harm the CPU and other output components. MP2935 provides RVP without additional system cost. The VOSEN pin monitors the output voltage: Any time the VOSEN pin voltage falls below -300 mV, MP2935 triggers RVP by latching all PWM outputs to a high-Z state. The reverse inductor current can quickly reset to 0A by dissipating the energy in the inductor through the input DC voltage source through the forward-biased body diode of the high-side MOSFETs.

Occasionally, OVP results in negative output voltage because turning on all low-side MOSFETs leads to very large reverse inductor current. The VR controller's RVP monitoring function remains active even after OVP latch-off to prevent damage to the load by negative voltage.

The RVP latch can only be reset by toggling enable, power cycling the VCC or when OVP occurs. See Figure 11.

### Over-current Protection

MP2935 uses VCM current,  $I_{VCM}$ , to detect an over-current condition. VCM current is continually compared to an internal reference current.  $I_{VCM}$  is provided by Intelli-Phase's™ CS pin, see "Current Sensing and IMON" section for details.

In N-phase configuration—where all phases are switching—the current limit occurs when the VCM current exceeds the OC threshold. The threshold is programmable via a resistor from OCPSET pin to ground. For most designs, select OC threshold about 130% of the rated current.

In power states PS<sub>n</sub> (where n = 1 through 3) running in single phase mode, the OC threshold is divided by N, i.e. 1/N. N is the number of operating phases for Power state 0 (PS0). See Table 4.

**Table 4: OCP Level during PS1/2/3**

	Over Current Trip Level		
	N=4	N=3	N=2
PS0	$I_{OC}$	$I_{OC}$	$I_{OC}$
PS1/2/3	$I_{OC}/4$	$I_{OC}/3$	$I_{OC}/2$

Whenever VCM current exceeds the OC threshold, an internal current limit amplifier controls the internal COMP voltage cycle-by-cycle to turn off the PWM to maintain peak current below the OC limit level.

If an OC event occurs for 1ms, an OC fault triggers and MP2935 shuts down with all PWM latched to high-Z output, as shown in Figure 12. The latch-off can only reset by either toggling VCC or toggling the EN pin. Program the OC level with the following equation:

$$R_{OCPSET} = \frac{1.024 \times 10^7}{I_{OC}}$$

MP2935 also has a per-phase current limit to limit each phase's duty cycle, so that each phase will not exceed a current level set by the user. This per-phase current limit can be programmed by setting a resistor from VCLAMP pin to ground.

$$R_{VCLAMP} = \frac{V_{COMP\_PEAK}}{I_{VCLAMP}}$$

$$V_{COMP\_PEAK} = R_{CS} \times (I_{Per\_Phase\_Limit} - I_{L\_PK-PK}) \times 10 \times 10^{-6} + \frac{V_{OUT}}{F_{SW} \times 3.424 \times 10 \times 10^{-6}} + 1$$

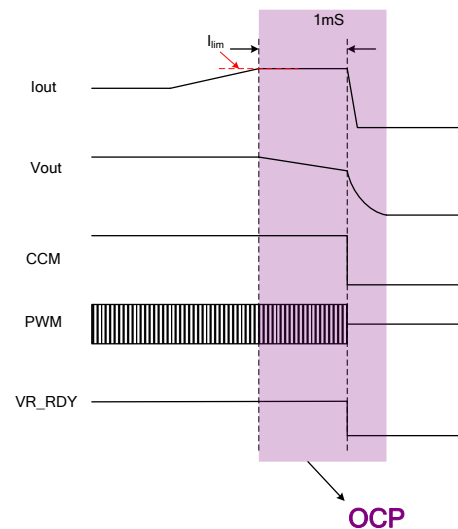

**Figure 12: OCP Fault Protection**

**Table 5: Summary of Fault Protection**

Fault	Fault Duration Prior to Protection	Protection Action	Comment
General Over-Current	1ms	An internal current limit amplifier controls the internal COMP voltage, turning off the PWM and monitors for OC events cycle-by-cycle to keep the current below the OC limit level. All PWMs are latched to high-Z output if OC occurs continuously for 1ms.	Always on
Over-Voltage of 3.4V	Immediate	PWMs are latched low and CCM is high.	Always on
Over-Voltage of VID+400mV	Immediate	PWMs are latched low and CCM is high.	Disabled during VID transition and during soft start.
Under-Voltage	1ms	All PWMs are latched to high-Z output when UV occurs for at least 1ms.	Always on
Reverse Voltage	Immediate	All PWMs are latched to high-Z output.	Always on
Over-Temperature	Immediate	VR_HOT# goes low.	Always on

### Monitoring (VR\_HOT#) and Temperature Zone

MP2935 provides a temperature sense pin TEMP and VR\_HOT# signal to indicate an over-temperature event. VR\_HOT# can be routed to various system thermal management controllers. VRHOT# pin is an open-drain output, active low and can be used to drive the CPU's force thermal throttle input.

The ADC converts the  $V_{TEMP}$  voltage to update the temperature zone register and compare this value with VRHOT# trip threshold programmed in the SVID register 22h.

For the ADC conversion,  $V_{TEMP}=0.9V$  equates to 64h stored in the register 17h.

MP2935 utilize Intelli-Phase's™ on-die temperature sensing output to monitor the hottest phase's junction temperature. Simply connects every Intelli-Phase's™ VTEMP pin to MP2935's TEMP. Connect a 1KΩ resistor from TEMP pin to ground to sink the voltage when temperature is going down.

VR\_HOT# trip point is programmable by TMAX pin. The hysteresis of VR\_HOT# is around 3% of the maximum temperature stored in the register 22h. The tolerance on VR\_HOT# should be  $\pm 4\%$  or approximately  $\pm 4^{\circ}C$  at  $100^{\circ}C$  setting.

$$R_{TMAX} = 250 \times TMAX$$

If the desire TMAX is  $100^{\circ}C$ , then select 25KΩ for  $R_{TMAX}$ .

### Start up Sequence

MP2935 must strictly follow the start-up sequence shown in Figure 13.

Figure 13 shows the diagrams of the start-up sequence described below:

- (1) VCC ramps up to 5V.
- (2) VR controllers receive hardware enable, i.e. EN is high. It takes  $35\mu s$  ( $T1$ ) from EN high to VDD ramped to 3.3V.
- (3) SVID bus exits Reset State when the VDD is higher than its UVLO threshold. The part is ready to accept SVID command 1.6ms ( $T2$ ) after VDD reached 3.3V.
- (4) Soft-start begins (DAC output starts to ramp up) 1.6ms ( $T2$ ) after VDD reached 3.3V. VR ramps to the  $V_{BOOT}$  voltage with slow slew rate. Once VR reached the  $V_{BOOT}$  voltage, it asserts VR\_SETTLE, ALERT# and VR\_RDY.<sup>(6)</sup>
- (5) Start up sequence finished.

#### Notes:

- 6) CPU determines when the ALERT# signal is cleared. It may clear ALERT# after the rail is up.

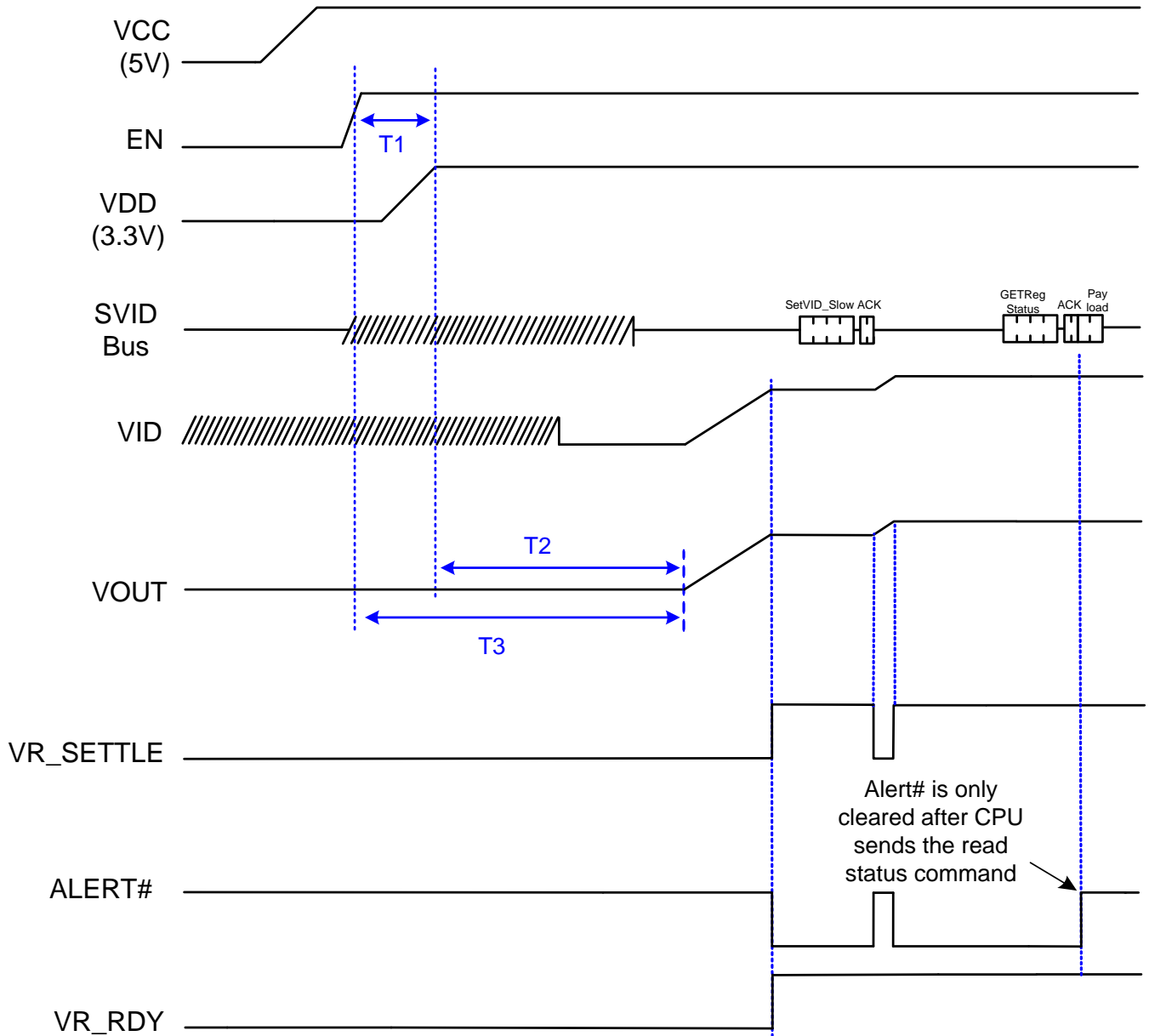

**Figure 13: Start-Up Sequence**

**SVID Operation and Registers**

The SVID operation and registers follow the VR12/IMVP7 SVID protocol, rev. 1.5, issued by Intel.

SVID is a three-wire (clock, data and alert) synchronous serial interface that transfers power management information between a master (the CPU) and slaves (MP2935). The clock is source-synchronous from the CPU. The master drives the SCLK signal with a low-voltage open drain driver, and may shut down the SCLK signal to save power in the absence of data to transfer. SDIO is a low-voltage, open-drain data signal that the master and slaves use to send information to each other. The pull-ups for SDIO

are a nominal 55Ω impedance bus. The reference voltage for SDIO and SCLK is the processor’s I/O voltage (typically  $V_{TT}=1.0-1.1V$ ). The bus operates up to a maximum frequency of 26.25MHz. The alert line, ALERT#, is an active-low signal driven asynchronously from the slave device, prompting the master to read the status register. All signals are routed between the master and the slave or multiple slaves on a common bus—the master CPU and the VR slaves are the only devices allowed on the bus.

Figure 14 shows the block diagram of the SVID controller.

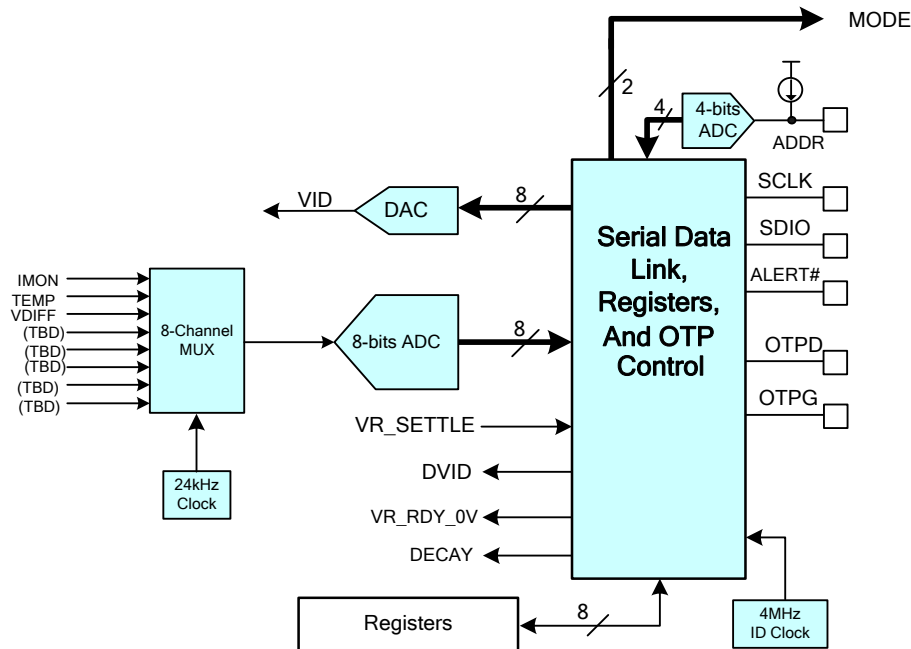

**Figure 14: Block Diagram of SVID Controller**

The VID slew rate control block digitally ramps up/down the 8-bit VIDs to the final VID codes set by master at a given slew rate. For example, if the VID chip gets a SetVID\_Fast command from the CPU with a new set of VIDs as the master payload contents, an internal register latches the new VIDs immediately. Meanwhile, an 8-bit counter starts to count up/down from the previous VIDs to the new codes. The internal clock determines the counting speed: The

MP2935 has a 4MHz internal ID clock and supports a slew rate of up to 20mV/μs.

When MP2935 receives 8-bit VID codes, it automatically converts the VIDs into an internal reference voltage. The FINAL\_VID signal, DVID, indicates that the SVID controller will finish VID ramping soon. DVID signal de-asserts once the VID controller gets a new VID command from CPU, then the SVID controller ramps up/down the VID code to the target VID step-by-step. DVID signal asserts again when the current

VID code is within 10mV or 1 VID step from the target voltage. DVID is the enable signal of VRSETTLE comparator. The sensed output voltage is compared to the DAC output to determine VRSETTLE signal when the DVID is asserted.

### SVID Address

To support multiple MP2935 used on the same SVID bus, use the ADDR pin to program the SVID address for each MP2935. There is a 10 $\mu$ A current on the ADDR pin; connect a resistor from ADDR pin to ground to set the ADDR voltage. The internal ADC converts the pin voltage to set the SVID address. Table 6 shows the SVID address for different resistor values from ADDR pin to ground.

Address 0xE and 0xF are reserved as an “All Call” address used for the CPU to communicate with all slave devices on the bus.

**Table 6: SVID Address vs ADDR Resistor**

R <sub>ADDR</sub> (k $\Omega$ )	Address (HEX)
0	0x0
11.8	0x1
19.6	0x2
28	0x3
35.7	0x4
44.2	0x5
51.1	0x6
59	0x7
68.1	0x8
80.6	0x9
88.7	0xA
95.3	0xB
105	0xC
133	0xD

## SVID COMMANDS

**Table 7: Supported SVID Commands**

Command		Master Payload Contents	Slave Payload Contents	Descriptions
01h	SetVID-Fast Individual Address and All Call Address	VID code	N/A	Set the new VID target. VR transitions to new a VID target at a controlled (up or down) slew rate programmed by the VR. When VR receives a VID moving-up command, it exits all low-power states to the normal state to ensure the fastest slew rate to the new VR.
02h	SetVID-Slow Individual Address and All Call Address	VID code	N/A	Set the VID target. VR transitions to new a VID target at a controlled slew rate (up or down) programmed by the VR. SetVID-Slow is 4x slower than SetVID-Fast. When VR receives a VID moving-up command it exits all low power states to the normal state to ensure a slow slew rate to the new VR.
03h	SetVID-Decay Individual ADDRESs and All Call Address	VID code	N/A	Sets the VID target, VR transitions to new the VID target, but does not control the slew rate; the output voltage decays at a rate proportional to the load current. SetVID_Decay is only used when VID is falling. VR sets VR_settled bit, but Alert line is not
04h	SetPS Individual Address and All Call Address	Byte indicating power status of CPU	N/A	Sends information to VR controller so it can configure VR to improve efficiency, especially at light load
05h	SetRegADR Individual Address Only. NAK All Call Address	Address of the index in the data table	N/A	Sets the address pointer in the data register table. Typically the next command, SetRegDAT, gets loaded into this address. However for multiple writes to the same address, use only one SetRegADR.
06h	SetRegDAT Individual Address Only. NAK All Call Address	New data register contents	N/A	Writes the contents to the data register that was previously identified by the address pointer with SetRegADR.
07h	GetReg Individual Address Only. NAK All Call Address	Define which register	Specified register contents	Slave returns the contents of the specified register as the payload. See Table 8 for list of registers The majority of the VR monitoring data is accessed through the GetReg command.



## SVID DATA AND CONFIGURATION REGISTERS

Table 8 shows the supported registers.

**Table 8: SVID Registers**

	Index	Register Name	Access	Default Value (OTP)
Registers 00h-06h are programmed by the VR vender at time of manufacture and are read only. This information is used to identify the vender's part in the field or during platform manufacture.	00h	Vendor ID	R	25h
	01h	Product ID	R	
	02h	Product Revision	R	
	03h	Date code	R	hard coded
	04h	Lot code	R	hard coded
	05h	protocol ID	R	02h (for VR12.5), hard code
	06h	capability	R	D7h
Registers 10h-18h are read-write telemetry data registers that the PWM controller updates. The Master can read these registers, but not write.	10h	Status_1	R	00h
	11h	Status_2	R	00h
	12h	Temperature Zone	R	00h
	15h	Output Current (I <sub>OUT</sub> )	R	actual I <sub>OUT</sub> measured after start-up
	16h	Output Voltage	R	
	17h	VR Temperature	R	
	18h	Output Power (P <sub>OUT</sub> )	R	
	19h	Input Current	R	
	1Ah	Input Voltage	R	
	1Bh	Input Power	R	
	1Ch	Status_2_last read	R	
Registers 21h-29h are OTP or pin-programmed with platform VR design points. If pin-programmed, the VR must load the data registers when its power is applied to the VR control IC.	21h	ICC_MAX	R	00h
	22h	Temp_MAX	R	96h (150C)
	24h	SR_Fast	R	0Ah (10mV/μs) 14h (20mV/μs)
	25h	SR_Slow	R	05h(5mV/μs) for fast@20mV/μs 02h (2.5mV/μs) for fast@10mV/μs
	26h	V <sub>BOOT</sub>	R	7Eh (1.75V)
Registers 30h-35h are scratch;pad registers, programmed by the Master with SetVID_X, SetPS or SetRegDAT commands. These registers revert to default values when power is removed.	30h	V <sub>OUT_MAX</sub>	RW	FFh (3.04V)
	31h	VID setting	RW	00h
	32h	PWR State	RW	00h
	33h	Offset	RW	00h
	34h	Multi VR Config	RW	00h
	35h	SetRegADR	RW	

# PACKAGE INFORMATION

## 6x6mm QFN40

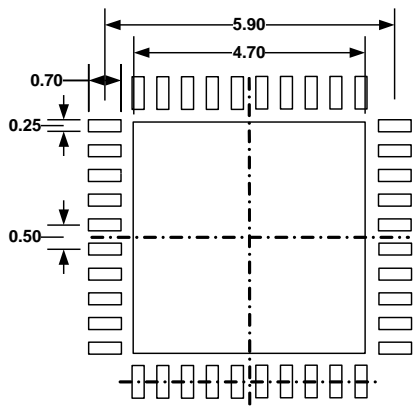
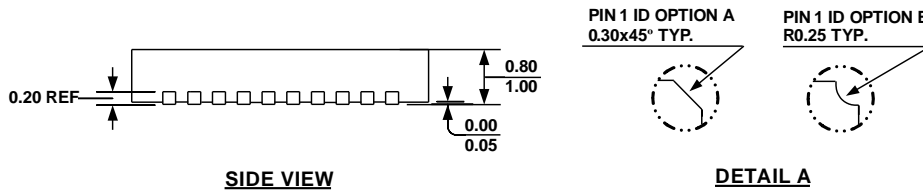
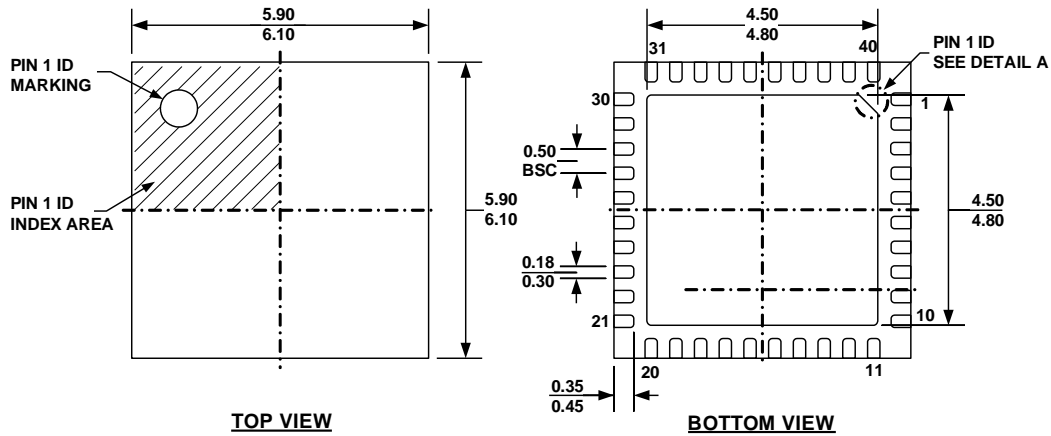

**RECOMMENDED LAND PATTERN**

**NOTE:**

- 1) ALL DIMENSIONS ARE IN MILLIMETERS
- 2) EXPOSED PADDLE SIZE DOES NOT INCLUDE MOLD FLASH
- 3) LEAD COPLANARITY SHALL BE 0.10 MILLIMETER MAX
- 4) DRAWING CONFORMS TO JEDEC MO-220, VARIATION VJJD-5.
- 5) DRAWING IS NOT TO SCALE