

Sine wave output filter for high-speed motor drives



- Smoothing of PWM drive output voltages
- Increased service life of expensive high-speed motors
- Reduction of audible motor noise
- Improvement of system reliability
- Production up-time for mission critical applications



Performance indicators

Typical motor power [kW]

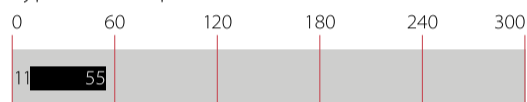

Rated current [A]

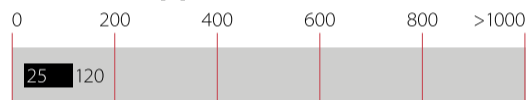

Approvals & Compliances

RoHS

Features and Benefits

- Suitable for fast rotating fields up to 600 Hz
- Conversion of the PWM output signal (symmetrical voltage components) of motor drives into a smooth sine wave with low residual ripple
- Elimination of premature motor damage caused by high dv/dt, overvoltages, motor overheating and eddy current losses
- Significantly increased service life of expensive (high-speed) motors
- Reduction of the pulse load of motor drive IGBTs and the parasitic losses on long shielded motor cables
- Less interference propagation towards neighboring equipment or lines
- Advanced choke design to minimize filter losses and voltage drop
- IP 20 protection, touch-safe terminals and temperature monitoring function to increase overall equipment safety

Technical Specifications

| | |
|---|--|
| Maximum continuous operating voltage dc link voltage | 3x 500/288 VAC |
| Motor frequency | 0 to 600 Hz |
| Switching frequency | 6 to 15 kHz |
| Rated currents | 25 to 120 A @ 50°C |
| Motor cable length | 200 m max. |
| Residual ripple voltage | <5% |
| High potential test voltage | P → E 2000 VAC for 2 sec P → P 1000 VDC for 2 sec |
| Protection category | IP 20 |
| Overload capability | 1.5x rated current for 1 minute, once per hour |
| Temperature range (operation and storage) | -25°C to +100°C (25/100/21) |
| Flammability corresponding to | UL 94 V-2 or better |
| Design corresponding to | UL 1283, CSA 22.2 No. 8 1986 |
| MTBF @ 50°C/400 V (Mil-HB-217F) | >100,000 hours |
| Lifetime (calculated) | >10 years (25, 55 A) ~5 years (75, 120 A) |

Typical Applications

Motor drives and motors in high-speed applications, like:

- High-speed spindles
- Textile machinery
- Lasers
- Military appliances (400 Hz)

Motor drive applications with medium to long motor cables and/or with multiple motors in parallel, like:

- Pumps
- Conveyors



Filter Selection Table

| Filter | Rated current Motor @ 50°C [A] | Typical motor power rating* [kW] | Typical power loss** [W] | Output connections  | Weight [kg] |
|----------------|--------------------------------------|--|--------------------------------|--|----------------|
| FN 5020-25-33 | 25 | 15 | n.a. | -33 | 13 |
| FN 5020-55-34 | 55 | 30 | n.a. | -34 | 29 |
| FN 5020-75-35 | 75 | 45 | n.a. | -35 | 49 |
| FN 5020-120-35 | 120 | 75 | n.a. | -35 | 57 |

* General purpose four-pole (1500 r/min) AC induction motor rated 480 V/50 Hz.

** Exact value highly depends upon the motor cable type and length, switching frequency, motor frequency and further stray parameters within the system. Please contact your local Schaffner partner for individual application support.

Typical Block Schematic

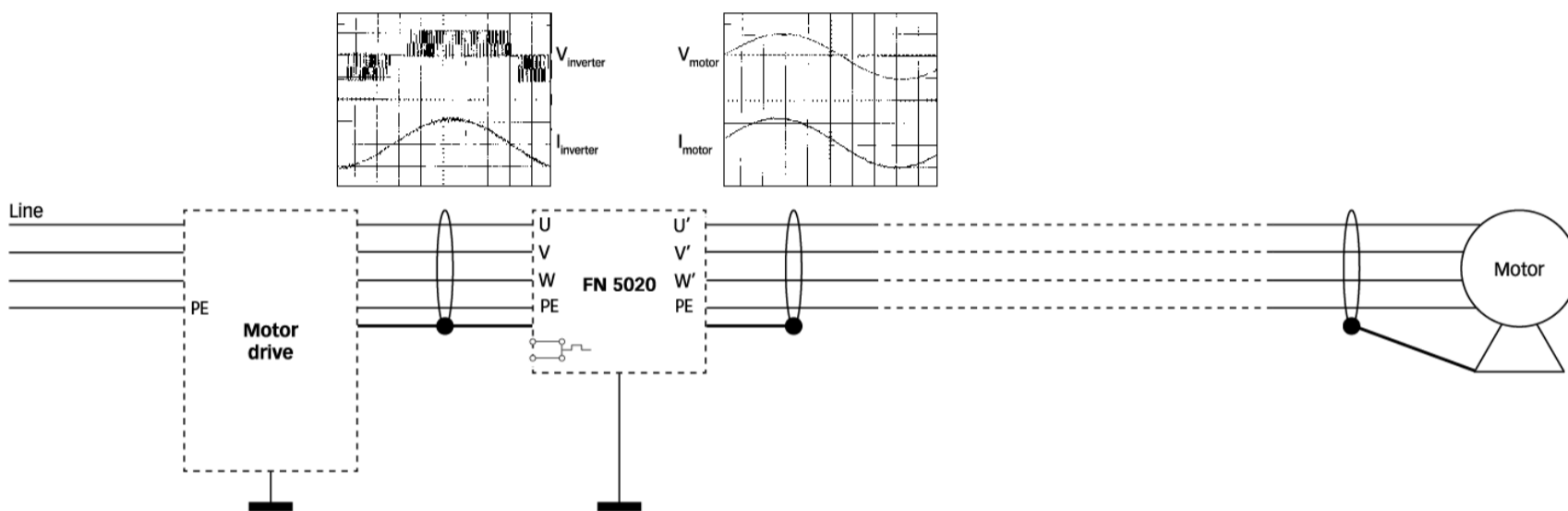

Temperature Monitoring Function

All filters of this range are equipped with a temperature monitoring function. The built-in temperature sensor opens a potential-free contact in the case of filter overtemperature (>120°C). The maximum switching capability is 6 A/250 V. This function can be used, for example, in the input of a CNC controller or as the trip of a circuit breaker in order to interrupt the mains power supply. Connections are located next to the phase connectors (see mechanical data for details).

Forced Cooling

The 75 A and 120 A filters provide internal cooling fans which require external power supply (24 VDC/~4 W). Connections are located next to the connectors of the temperature sensor (see mechanical data for details).

For additional information please consult the Schaffner application note „Sinus Plus – New Output Filter Concept for Power Drive Systems“.

Mechanical Data

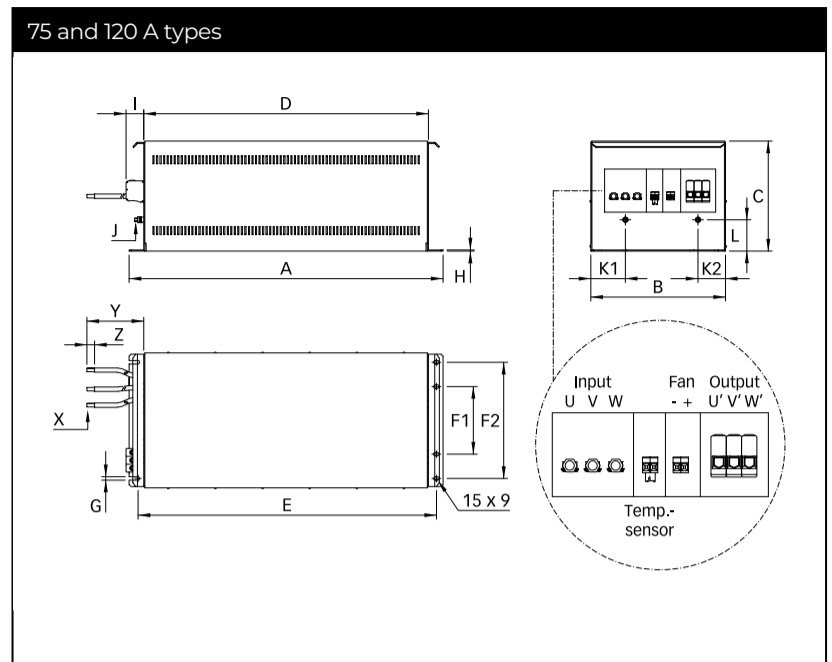
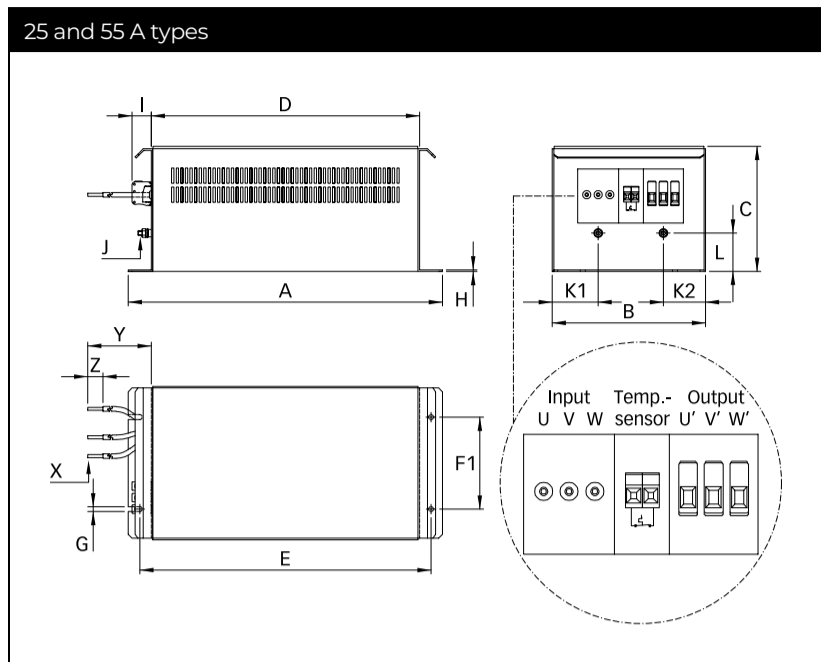

Dimensions

| | 25 A | 55 A | 75 A | 120 A |
|-----------|-------------|-------------|-------------------|-------------------|
| A | 410 | 554 | 799 | 799 |
| B | 200 | 250 | 343 | 343 |
| C | 163 | 203 | 280 | 280 |
| D | 350 | 500 | 725 | 725 |
| E | 380 | 524 | 760 | 760 |
| F1 | 120 | 170 | 172 | 172 |
| F2 | | | 296 | 296 |
| G | 6.5 | 9 | 9 | 9 |
| H | 2 | 3 | 3 | 3 |
| I | 25 | 39 | 45 | 45 |
| J | M6 | M6 | M8 | M8 |
| K1 | 60 | 70 | 88 | 88 |
| K2 | 55 | 55 | 70 | 70 |
| L | 50 | 69 | 80 | 80 |
| X | AWG 10 | AWG 6 | 25mm ² | 35mm ² |
| Y | 1000 +20/-0 | 1000 +20/-0 | 1000 +20/-0 | 1000 +20/-0 |
| Z | 20 | 20 | 20 | 20 |

All dimensions in mm; 1 inch = 25.4 mm
 Tolerances according: ISO 2768-m / EN 22768-m

Filter Output Connector Cross Sections

| | -29 | -33 | -34 | -35 |
|---------------------------|-----------------------|------------------------|------------------------|------------------------|
| Solid wire | 6 mm ² | 16 mm ² | 35 mm ² | 50 mm ² |
| Flex wire | 4 mm ² | 10 mm ² | 25 mm ² | 50 mm ² |
| AWG type wire | AWG 10 | AWG 6 | AWG 2 | AWG 1/0 |
| Recommended torque | 0.6-0.8 Nm | 1.5-1.8 Nm | 4.0-4.5 Nm | 7-8 Nm |

Please visit www.schaffner.com to find more details on filter connectors.

Headquarters, Global Innovation and Development

Switzerland

Schaffner Holding AG

Industrie Nord
Nordstrasse 11e
4542
Luterbach
+41 32 681 66 26
info@schaffner.com

Sales and Application Centers

Switzerland

Schaffner EMV AG

Industrie Nord
Nordstrasse 11e
4542
Luterbach
+41 32 681 66 26
switzerlandsales@schaffner.com

China

Schaffner EMC Ltd. Shanghai

T20-3 C, No 565 Chuangye Road, Pudong
district
201201
Shanghai
+86 2138139500
cschina@schaffner.com

Singapore

Schaffner EMC Pte Ltd.

Blk 3015A Ubi Road 1, #05-09, Kampong Ubi
Industrial Estate
408705
Singapore
+65 63773283
singaporesales@schaffner.com

To find your local partner within
Schaffner's global network schaffner.com

© 2022 Schaffner Group

The content of this document has been carefully checked and understood. However, neither Schaffner nor its subsidiaries assume any liability whatsoever for any errors or inaccuracies of this document and the consequences thereof. Published specifications are subject to change without notice. Product suitability for any area of application must ultimately be determined by the customer. In all cases, products must never be operated outside their published specifications. Schaffner does not guarantee the availability of all published products. This disclaimer shall be governed by substantive Swiss law and resulting disputes shall be settled by the courts at the place of business of Schaffner Holding AG. Latest publications and a complete disclaimer can be downloaded from the Schaffner website. All trademarks recognized.