

To our customers,

Old Company Name in Catalogs and Other Documents

On April 1st, 2010, NEC Electronics Corporation merged with Renesas Technology Corporation, and Renesas Electronics Corporation took over all the business of both companies. Therefore, although the old company name remains in this document, it is a valid Renesas Electronics document. We appreciate your understanding.

Renesas Electronics website: <http://www.renesas.com>

April 1st, 2010
Renesas Electronics Corporation

Issued by: Renesas Electronics Corporation (<http://www.renesas.com>)

Send any inquiries to <http://www.renesas.com/inquiry>.

Notice

1. All information included in this document is current as of the date this document is issued. Such information, however, is subject to change without any prior notice. Before purchasing or using any Renesas Electronics products listed herein, please confirm the latest product information with a Renesas Electronics sales office. Also, please pay regular and careful attention to additional and different information to be disclosed by Renesas Electronics such as that disclosed through our website.
2. Renesas Electronics does not assume any liability for infringement of patents, copyrights, or other intellectual property rights of third parties by or arising from the use of Renesas Electronics products or technical information described in this document. No license, express, implied or otherwise, is granted hereby under any patents, copyrights or other intellectual property rights of Renesas Electronics or others.
3. You should not alter, modify, copy, or otherwise misappropriate any Renesas Electronics product, whether in whole or in part.
4. Descriptions of circuits, software and other related information in this document are provided only to illustrate the operation of semiconductor products and application examples. You are fully responsible for the incorporation of these circuits, software, and information in the design of your equipment. Renesas Electronics assumes no responsibility for any losses incurred by you or third parties arising from the use of these circuits, software, or information.
5. When exporting the products or technology described in this document, you should comply with the applicable export control laws and regulations and follow the procedures required by such laws and regulations. You should not use Renesas Electronics products or the technology described in this document for any purpose relating to military applications or use by the military, including but not limited to the development of weapons of mass destruction. Renesas Electronics products and technology may not be used for or incorporated into any products or systems whose manufacture, use, or sale is prohibited under any applicable domestic or foreign laws or regulations.
6. Renesas Electronics has used reasonable care in preparing the information included in this document, but Renesas Electronics does not warrant that such information is error free. Renesas Electronics assumes no liability whatsoever for any damages incurred by you resulting from errors in or omissions from the information included herein.
7. Renesas Electronics products are classified according to the following three quality grades: "Standard", "High Quality", and "Specific". The recommended applications for each Renesas Electronics product depends on the product's quality grade, as indicated below. You must check the quality grade of each Renesas Electronics product before using it in a particular application. You may not use any Renesas Electronics product for any application categorized as "Specific" without the prior written consent of Renesas Electronics. Further, you may not use any Renesas Electronics product for any application for which it is not intended without the prior written consent of Renesas Electronics. Renesas Electronics shall not be in any way liable for any damages or losses incurred by you or third parties arising from the use of any Renesas Electronics product for an application categorized as "Specific" or for which the product is not intended where you have failed to obtain the prior written consent of Renesas Electronics. The quality grade of each Renesas Electronics product is "Standard" unless otherwise expressly specified in a Renesas Electronics data sheets or data books, etc.

"Standard": Computers; office equipment; communications equipment; test and measurement equipment; audio and visual equipment; home electronic appliances; machine tools; personal electronic equipment; and industrial robots.

"High Quality": Transportation equipment (automobiles, trains, ships, etc.); traffic control systems; anti-disaster systems; anti-crime systems; safety equipment; and medical equipment not specifically designed for life support.

"Specific": Aircraft; aerospace equipment; submersible repeaters; nuclear reactor control systems; medical equipment or systems for life support (e.g. artificial life support devices or systems), surgical implantations, or healthcare intervention (e.g. excision, etc.), and any other applications or purposes that pose a direct threat to human life.

8. You should use the Renesas Electronics products described in this document within the range specified by Renesas Electronics, especially with respect to the maximum rating, operating supply voltage range, movement power voltage range, heat radiation characteristics, installation and other product characteristics. Renesas Electronics shall have no liability for malfunctions or damages arising out of the use of Renesas Electronics products beyond such specified ranges.
9. Although Renesas Electronics endeavors to improve the quality and reliability of its products, semiconductor products have specific characteristics such as the occurrence of failure at a certain rate and malfunctions under certain use conditions. Further, Renesas Electronics products are not subject to radiation resistance design. Please be sure to implement safety measures to guard them against the possibility of physical injury, and injury or damage caused by fire in the event of the failure of a Renesas Electronics product, such as safety design for hardware and software including but not limited to redundancy, fire control and malfunction prevention, appropriate treatment for aging degradation or any other appropriate measures. Because the evaluation of microcomputer software alone is very difficult, please evaluate the safety of the final products or system manufactured by you.
10. Please contact a Renesas Electronics sales office for details as to environmental matters such as the environmental compatibility of each Renesas Electronics product. Please use Renesas Electronics products in compliance with all applicable laws and regulations that regulate the inclusion or use of controlled substances, including without limitation, the EU RoHS Directive. Renesas Electronics assumes no liability for damages or losses occurring as a result of your noncompliance with applicable laws and regulations.
11. This document may not be reproduced or duplicated, in any form, in whole or in part, without prior written consent of Renesas Electronics.
12. Please contact a Renesas Electronics sales office if you have any questions regarding the information contained in this document or Renesas Electronics products, or if you have any other inquiries.

(Note 1) "Renesas Electronics" as used in this document means Renesas Electronics Corporation and also includes its majority-owned subsidiaries.

(Note 2) "Renesas Electronics product(s)" means any product developed or manufactured by or for Renesas Electronics.

The revision list can be viewed directly by clicking the title page.

The revision list summarizes the locations of revisions and additions. Details should always be checked by referring to the relevant text.

SH7709S Group

Hardware Manual

Renesas 32-Bit RISC

Microcomputer

SuperH™ RISC engine Family/

SH7700 Series

Renesas 32-Bit RISC Microcomputer
SuperH™ RISC engine Family/SH7700 Series

SH7709S Group

Hardware Manual

RENESAS

REJ09B0081-05000

Cautions

Keep safety first in your circuit designs!

1. Renesas Technology Corp. puts the maximum effort into making semiconductor products better and more reliable, but there is always the possibility that trouble may occur with them. Trouble with semiconductors may lead to personal injury, fire or property damage. Remember to give due consideration to safety when making your circuit designs, with appropriate measures such as (i) placement of substitutive, auxiliary circuits, (ii) use of nonflammable material or (iii) prevention against any malfunction or mishap.

Notes regarding these materials

1. These materials are intended as a reference to assist our customers in the selection of the Renesas Technology Corp. product best suited to the customer's application; they do not convey any license under any intellectual property rights, or any other rights, belonging to Renesas Technology Corp. or a third party.
2. Renesas Technology Corp. assumes no responsibility for any damage, or infringement of any third-party's rights, originating in the use of any product data, diagrams, charts, programs, algorithms, or circuit application examples contained in these materials.
3. All information contained in these materials, including product data, diagrams, charts, programs and algorithms represents information on products at the time of publication of these materials, and are subject to change by Renesas Technology Corp. without notice due to product improvements or other reasons. It is therefore recommended that customers contact Renesas Technology Corp. or an authorized Renesas Technology Corp. product distributor for the latest product information before purchasing a product listed herein. The information described here may contain technical inaccuracies or typographical errors. Renesas Technology Corp. assumes no responsibility for any damage, liability, or other loss rising from these inaccuracies or errors. Please also pay attention to information published by Renesas Technology Corp. by various means, including the Renesas Technology Corp. Semiconductor home page (<http://www.renesas.com>).
4. When using any or all of the information contained in these materials, including product data, diagrams, charts, programs, and algorithms, please be sure to evaluate all information as a total system before making a final decision on the applicability of the information and products. Renesas Technology Corp. assumes no responsibility for any damage, liability or other loss resulting from the information contained herein.
5. Renesas Technology Corp. semiconductors are not designed or manufactured for use in a device or system that is used under circumstances in which human life is potentially at stake. Please contact Renesas Technology Corp. or an authorized Renesas Technology Corp. product distributor when considering the use of a product contained herein for any specific purposes, such as apparatus or systems for transportation, vehicular, medical, aerospace, nuclear, or undersea repeater use.
6. The prior written approval of Renesas Technology Corp. is necessary to reprint or reproduce in whole or in part these materials.
7. If these products or technologies are subject to the Japanese export control restrictions, they must be exported under a license from the Japanese government and cannot be imported into a country other than the approved destination. Any diversion or reexport contrary to the export control laws and regulations of Japan and/or the country of destination is prohibited.
8. Please contact Renesas Technology Corp. for further details on these materials or the products contained therein.

General Precautions on Handling of Product

1. Treatment of NC Pins

Note: Do not connect anything to the NC pins.

The NC (not connected) pins are either not connected to any of the internal circuitry or are used as test pins or to reduce noise. If something is connected to the NC pins, the operation of the LSI is not guaranteed.

2. Treatment of Unused Input Pins

Note: Fix all unused input pins to high or low level.

Generally, the input pins of CMOS products are high-impedance input pins. If unused pins are in their open states, intermediate levels are induced by noise in the vicinity, a pass-through current flows internally, and a malfunction may occur.

3. Processing before Initialization

Note: When power is first supplied, the product's state is undefined.

The states of internal circuits are undefined until full power is supplied throughout the chip and a low level is input on the reset pin. During the period where the states are undefined, the register settings and the output state of each pin are also undefined. Design your system so that it does not malfunction because of processing while it is in this undefined state. For those products which have a reset function, reset the LSI immediately after the power supply has been turned on.

4. Prohibition of Access to Undefined or Reserved Addresses

Note: Access to undefined or reserved addresses is prohibited.

The undefined or reserved addresses may be used to expand functions, or test registers may have been allocated to these addresses. Do not access these registers; the system's operation is not guaranteed if they are accessed.

Configuration of This Manual

This manual comprises the following items:

1. General Precautions on Handling of Product
2. Configuration of This Manual
3. Preface
4. Contents
5. Overview
6. Description of Functional Modules

- CPU and System-Control Modules
- On-Chip Peripheral Modules

The configuration of the functional description of each module differs according to the module. However, the generic style includes the following items:

- i) Feature
- ii) Input/Output Pin
- iii) Register Description
- iv) Operation
- v) Usage Note

When designing an application system that includes this LSI, take notes into account. Each section includes notes in relation to the descriptions given, and usage notes are given, as required, as the final part of each section.

7. List of Registers
8. Electrical Characteristics
9. Appendix
10. Main Revisions and Additions in this Edition (only for revised versions)

The list of revisions is a summary of points that have been revised or added to earlier versions. This does not include all of the revised contents. For details, see the actual locations in this manual.

11. Index

Preface

This LSI is a microprocessor with the 32-bit SH-3 CPU as its core and peripheral functions necessary for configuring a user system.

This LSI is built in with a variety of peripheral functions such as cache memory, memory management unit (MMU), interrupt controller, timer, three serial communication interfaces, real-time clock (RTC), use break controller (UBC), bus state controller (BSC) and I/O ports.

This LSI can be used as a microcomputer for devices that require both high speed and low power consumption.

Target Readers: This manual is designed for use by people who design application systems using the SH7709S.

To use this manual, basic knowledge of electric circuits, logic circuits and microcomputers is required.

Purpose: This manual provides the information of the hardware functions and electrical characteristics of the SH7709S.

The SH3, SH-3E, SH3-DSP Programming Manual contains detailed information of executable instructions. Please read the Programming Manual together with this manual.

How to Use the Book:

- To understand general functions
 - Read the manual from the beginning.
The manual explains the CPU, system control functions, peripheral functions and electrical characteristics in that order.
- To understanding CPU functions
 - Refer to the separate SH3, SH-3E, SH3-DSP Programming Manual.

Explanatory Note: Bit sequence: upper bit at left, and lower bit at right

List of Related Documents: The latest documents are available on our Web site. Please make sure that you have the latest version.

(<http://www.renesas.com/eng/>)

- User manuals for SH7709S

Name of Document	Document No.
SH7709S Group Hardware Manual	This manual
SH3, SH-3E, SH3-DSP Programming Manual	ADE-602-156

- User manuals for development tools

Name of Document	Document No.
C/C++ Compiler, Assembler, Optimizing Linkage Editor User's Manual	ADE-702-246
Simulator/Debugger User's Manual	ADE-702-186
Embedded Workshop User's Manual	ADE-702-201

List of Items Revised or Added for This Version

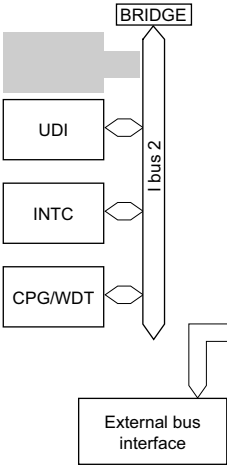
Section	Page	Description
1.2 Block Diagram Figure 1.1 Block Diagram	6	<p>ASERAM deleted from figure</p>  <p>The diagram shows a vertical bus labeled 'I bus 2'. At the top is a box labeled 'BRIDGE'. Below it are three boxes: 'UDI', 'INTC', and 'CPG/WDT', each connected to the bus by a diamond-shaped symbol. At the bottom of the bus is an 'External bus interface' box, also connected by a diamond-shaped symbol. A greyed-out box is visible to the left of the UDI, INTC, and CPG/WDT boxes.</p> <p>ASERAM deleted from legend</p>
2.5.1 Processor States	53	<p>Description amended</p> <p>In the power-on reset state, the internal states of the CPU and the on-chip supporting module registers are initialized. In the manual reset state, the internal states of the CPU and registers of on-chip supporting modules other than the bus state controller (BSC) are initialized. [REDACTED] Refer to the register configurations in the relevant sections for further details.</p>
5.4 Memory-Mapped Cache 5.4.1 Address Array	113	<p>Description amended</p> <p>[REDACTED] This operation is used to invalidate the address specification for a cache. Write back will take place when the U bit of the entry that received a hit is 1. Note that, when a 0 is written to the V bit, a 0 should always be written to the U bit of the same entry, too.</p>

Section	Page	Description
5.4.3 Examples of Usage	115, 116	<p>(1) Invalidating a Specific Entry</p> <p>Description amended</p> <p>A specific cache entry can be invalidated by accessing the allocated memory cache and writing a 0 to the entry's U and V bits. The A bit is cleared to 0, and an address is specified for the entry address and the way. If the U bit of the way of the entry in question was set to 1, the entry is written back and the V and U bits specified by the write data are written to.</p> <p>In the following example, the write data is specified in R0 and the address is specified in R1.</p> <pre>; R0 = H'0000 0000 LRU = H'000, U = 0, V = 0 ; R1 = H'F000 1080, Way = 1, Entry = H'08, A = 0 ; MOV.L R0, @R1</pre> <p>To invalidate all entries and ways, write 0 to the following addresses.</p> <pre>Addresses F000 0000 F000 0010 F000 0020 : F000 3FF0</pre> <p>This involves a total of 1,024 writes.</p> <p>The above operation should be performed using a non-cacheable area.</p>
6.2.6 Interrupt Exception Handling and Priority	127	<p>(2) Invalidating a Specific Address</p> <p>Newly added</p> <p>(3) Reading Data from a Specific Entry</p> <p>Description amended</p> <pre>; R0 = H'F100 004C; Data array access, Entry = H'04, ; Way = 0, Longword address = 3 ; MOV.L R0, @R1 ; Longword 3 is read.</pre>
Table 6.4 Interrupt Exception Handling Sources and Priority (IRQ Mode)		
6.3.6 Interrupt Request Register 0 (IRR0)	138	<p>Description amended</p> <p>When clearing an IRQ5R–IRQ0R bit to 0, read the bit while bit set to 1, and then write 0. In this case, 0 should be written only to the bits to be cleared and 1 to the other bits. The contents of the bits to which 1 is written do not change.</p>
8.2.1 Standby Control Register (STBCR)	184	<p>Description added</p> <p>Bit 1—Module Standby 1 (MSTP1)</p> <p>Before switching the RTC to module standby, access at least one among the registers RTC, SCI, and TMU.</p>

Section	Page	Description
8.3.3 Precautions when Using the Sleep Mode	187	Newley added
8.5.1 Transition to Module Standby Function	191	Note *3 added to bit table Note: 3. Before putting the RTC into module standby status, first access one or more of the RTC, SCI, and TMU registers. The RTC may then be put into module standby status.
9.3 Clock Operating Modes Table 9.4 Available Combinations of Clock Mode and FRQCR Values	210	2. under cautions amended The peripheral clock frequency should not be set higher than the frequency of the CKIO pin, higher than 33.34 MHz.
9.5.1 Changing the Multiplication Rate	213	Description added 5. Supply of the clock that has been set begins at WDT count overflow, and the processor begins operating again. The WDT stops after it overflows. When the following three conditions are all met, FRQCR should not be changed while a DMAC transfer is in progress. <ul style="list-style-type: none"> • Bits IFC2 to IFC0 are changed. • STC2 to STC0 are not changed. • The clock ratio of Iϕ (on-chip clock) to Bϕ (bus clock) after the change is other than 1:1.
9.8.2 Changing the Frequency	218, 219	Description added 5. The counter stops at a value of H'00 or H'01. The stop value depends on the clock ratio. When the following three conditions are all met, FRQCR should not be changed while a DMAC transfer is in progress. <ul style="list-style-type: none"> • Bits IFC2 to IFC0 are changed. • STC2 to STC0 are not changed. • The clock ratio of Iϕ (on-chip clock) to Bϕ (bus clock) after the change is other than 1:1.
10.1.1 Features	223	Refresh function description deleted
10.2.5 Individual Memory Control Register (MCR)	246	Description added Bit 7—Synchronous DRAM Bank Active (RASD): Specifies whether synchronous DRAM is used in bank active mode or auto-precharge mode. Set auto-precharge mode when areas 2 and 3 are both designated as synchronous DRAM space. The bank active mode should not be used unless the bus width for all areas is 32 bits.

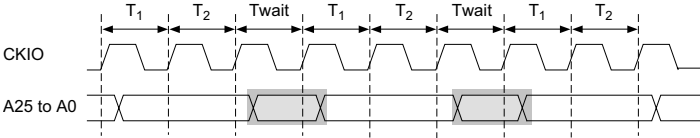
Section	Page	Description
10.2.13 MCS0 Control Register (MCSCR0)	258	Description added Bit 6—CS2/CS0 Select (CS2/0) Only 0 should be used for the CS2/0 bit in MCSCR0. Either 0 or 1 may be used for MCSCR1 to MCSCR7.
10.3.4 Synchronous DRAM Interface	290	Bank Active description addedIn bank active mode, too, all banks become inactive after a refresh cycle or after the bus is released as the result of bus arbitration. The bank active mode should not be used unless the bus width for all areas is 32 bits.
10.3.6 PCMCIA Interface Figure 10.32 Basic Timing for PCMCIA Memory Card Interface	310	Figure amended D15 to D0 (Write)
10.3.7 Waits between Access Cycles Figure 10.40 Waits between Access Cycles	320	Figure amended 
10.3.10 MCS[0] to MCS[7] Pin Control	323	Description amended This enables 32-, 64-, 128-, or 256-Mbit memory to be connected to area 0 or area 2. However, only CS2/0 = 0 (area 0) should be used for MCSCR0. Table 10.15 shows MCSCR0–MCSCR7 settings and MCS[0]–MCS[7] assertion conditions.
11.6 Usage Notes	387	Description added 13. DMAC transfers should not be performed in the sleep mode under conditions other than when the clock ratio of I ϕ (on-chip clock) to B ϕ (bus clock) is 1:1. 14. When the following three conditions are all met, the frequency control register (FRQCR) should not be changed while a DMAC transfer is in progress. <ul style="list-style-type: none"> • Bits IFC2 to IFC0 are changed. • STC2 to STC0 in FRQCR are not changed. • The clock ratio of Iϕ (on-chip clock) to Bϕ (bus clock) after the change is other than 1:1.
13.4.3 Precautions when Using RTC Module Standby	426	Newly added

Section	Page	Description
16.4 SCIF Interrupts	550	<p>Description amended</p> <p>When the TDFE flag in the serial status register (SCSSR) is set to 1, a TXI interrupt request is generated. The DMAC can be activated and data transfer performed when this interrupt is generated. When data exceeding the transmit trigger number is written to the transmit data register (SCFTDR) by the DMAC, 1 is read from the TDFE flag, after which 0 is written to it to clear it.</p> <p>When the RDF flag in SCSSR is set to 1, an RXI interrupt request is generated. The DMAC can be activated and data transfer performed when the RDF flag in SCSSR is set to 1. When receive data less than the receive trigger number is read from the receive data register (SCFRDR) by the DMAC, 1 is read from the RDF flag, after which 0 is written to it to clear it.</p>
16.5 Usage Notes	551	<p>Description amended</p> <p>1. SCFTDR Writing and TDFE Flag: However, if the number of data bytes written to SCFTDR is equal to or less than the transmit trigger number, the TDFE flag will be set to 1 again even after having been cleared to 0. TDFE clearing should therefore be carried out after data exceeding the specified transmit trigger number has been written to SCFTDR.</p> <p>2. SCFRDR Reading and RDF Flag: However, if the number of data bytes in SCFRDR exceeds the trigger number, the RDF flag will be set to 1 again even after having been cleared to 0. RDF should therefore be cleared to 0 after being read as 1 after all the receive data has been read.</p>
19.13.2 SC Port Data Register (SCPDR)	610	Title Amended

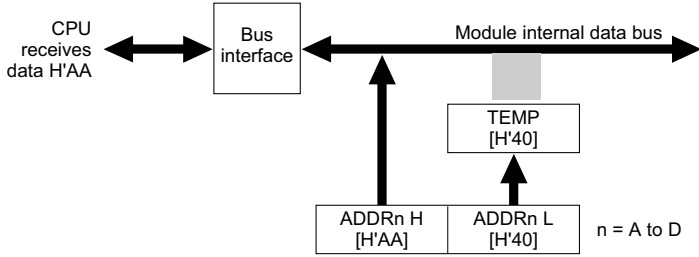
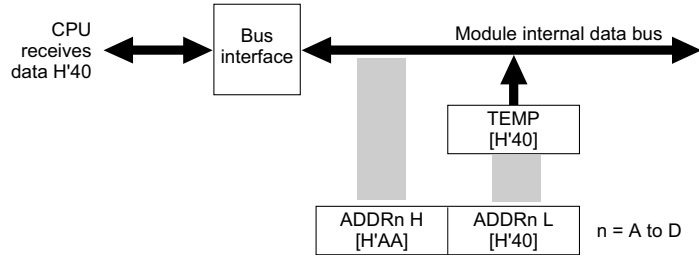
Section	Page	Description
20.3 Bus Master Interface Figure 20.2 A/D Data Register Access Operation (Reading H'AA40)	622	Figure amended Upper byte read  Lower byte read 

23.1 Absolute Maximum Ratings Table 23.1 Absolute Maximum Ratings	657	Caution added 2.Until voltage is applied to all power supplies, a low level is input at the $\overline{\text{RESETP}}$ pin, and CKIO has operated for a maximum of 4 clock cycles, internal circuits remain unsettled, and so pin states are also undefined. The system design must ensure that these undefined states do not cause erroneous system operation. Note that the $\overline{\text{RESETP}}$ pin cannot receive a low level signal while a low level signal is being input to the CA pin.
--	-----	---

23.2 DC Characteristics Table 23.2 DC Characteristics	659, 662	Test conditions for in sleep mode amended <table border="1"> <thead> <tr> <th>Item</th> <th>Symbol</th> <th>Min</th> <th>Typ</th> <th>Max</th> <th>Unit</th> <th>Test Conditions</th> </tr> </thead> <tbody> <tr> <td rowspan="2">Sleep mode*¹</td> <td>I_{cc}</td> <td>—</td> <td>15</td> <td>30</td> <td></td> <td rowspan="2">*¹: When there is no other external bus cycle other than the refresh cycle. V_{cc} = 1.9 V V_{ccQ} = 3.3 V Bϕ = 33MHz</td> </tr> <tr> <td>I_{ccQ}</td> <td>—</td> <td>10</td> <td>20</td> <td></td> </tr> </tbody> </table> <p>Note * added * If the IRL and IRLS interrupts are used, the minimum is 1.9 V.</p>	Item	Symbol	Min	Typ	Max	Unit	Test Conditions	Sleep mode* ¹	I _{cc}	—	15	30		* ¹ : When there is no other external bus cycle other than the refresh cycle. V _{cc} = 1.9 V V _{ccQ} = 3.3 V B ϕ = 33MHz	I _{ccQ}	—	10	20	
Item	Symbol	Min	Typ	Max	Unit	Test Conditions															
Sleep mode* ¹	I _{cc}	—	15	30		* ¹ : When there is no other external bus cycle other than the refresh cycle. V _{cc} = 1.9 V V _{ccQ} = 3.3 V B ϕ = 33MHz															
	I _{ccQ}	—	10	20																	

23.3.6 Synchronous DRAM Timing

690

Tnop cycle deleted from figure

Figure 23.31
Synchronous DRAM
Burst Read Bus Cycle
(RAS Down, Same Row
Address, CAS Latency
= 2)

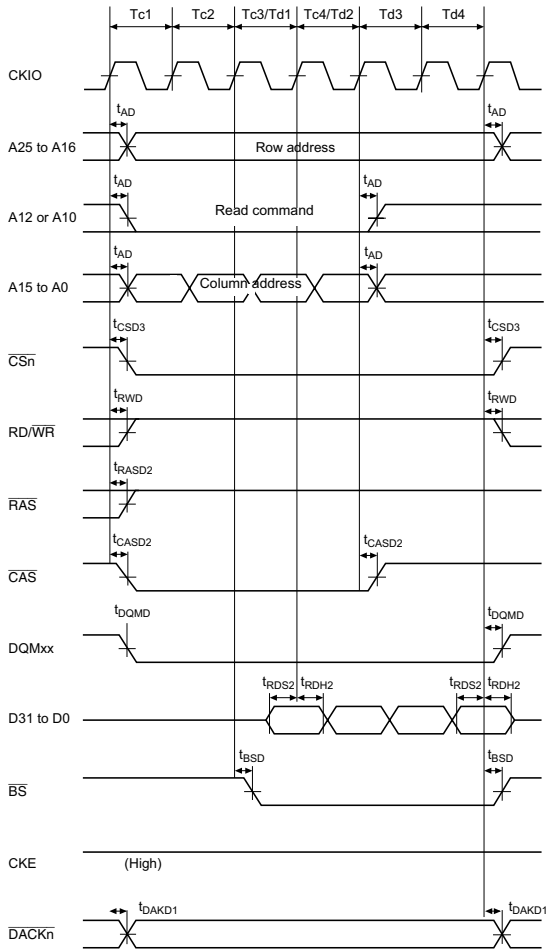

Section	Page	Description																				
A.2 Pin Specifications Table A.2 Pin Specifications	723	Function information amended for V _{CC} -RTC, V _{CC} -PLL1, V _{CC} -PLL2, and V _{CC}																				
		<table border="1"> <thead> <tr> <th>Pin</th> <th>Pin No. (FP-208C, FP-208E)</th> <th>Pin No. (BP- 240A)</th> <th>I/O</th> <th>Function</th> </tr> </thead> <tbody> <tr> <td>V_{CC}- RTC</td> <td>3</td> <td>E2</td> <td>Power supply</td> <td>RTC oscillator power supply (2.0/1.9/1.8/1.7 V)</td> </tr> <tr> <td>V_{CC}- PLL1 V_{CC}- PLL2</td> <td>145 150</td> <td>F16, E17</td> <td>Power supply</td> <td>PLL power supply (2.0/1.9/1.8/1.7 V)</td> </tr> <tr> <td>V_{CC}</td> <td>29, 81, 134, 154, 175</td> <td>L3, L4, U11, T11, J17, J16, E18, C19, C12, D12</td> <td>Power supply</td> <td>Internal power supply (2.0/1.9/1.8/1.7 V)</td> </tr> </tbody> </table>	Pin	Pin No. (FP-208C, FP-208E)	Pin No. (BP- 240A)	I/O	Function	V _{CC} - RTC	3	E2	Power supply	RTC oscillator power supply (2.0/1.9/1.8/1.7 V)	V _{CC} - PLL1 V _{CC} - PLL2	145 150	F16, E17	Power supply	PLL power supply (2.0/1.9/1.8/1.7 V)	V _{CC}	29, 81, 134, 154, 175	L3, L4, U11, T11, J17, J16, E18, C19, C12, D12	Power supply	Internal power supply (2.0/1.9/1.8/1.7 V)
Pin	Pin No. (FP-208C, FP-208E)	Pin No. (BP- 240A)	I/O	Function																		
V _{CC} - RTC	3	E2	Power supply	RTC oscillator power supply (2.0/1.9/1.8/1.7 V)																		
V _{CC} - PLL1 V _{CC} - PLL2	145 150	F16, E17	Power supply	PLL power supply (2.0/1.9/1.8/1.7 V)																		
V _{CC}	29, 81, 134, 154, 175	L3, L4, U11, T11, J17, J16, E18, C19, C12, D12	Power supply	Internal power supply (2.0/1.9/1.8/1.7 V)																		
A.3 Treatment of Unused Pins	724	"When RTC is not used" and "When PLL2 is not used" amended (Before) (1.9/1.8V) →(After) (2.0/1.9/1.8/1.7V)																				
A.4 Pin States in Access to Each Address Space Table A.3 Pin States (Ordinary Memory/Little Endian) Table A.4 Pin States (Ordinary Memory/Big Endian) Table A.5 Pin States (Burst ROM/Little Endian) Table A.6 Pin States (Burst ROM/Big Endian) Table A.9 Pin States (PCMCIA/Little Endian) Table A.10 Pin States (PCMCIA/Big Endian)	726 to 738	Note 2 amended Note: 2. Unused data pins should be switched to the port function, or pulled up.																				

Contents

Section 1	Overview and Pin Functions.....	1
1.1	SH7709S Features	1
1.2	Block Diagram	6
1.3	Pin Description	7
1.3.1	Pin Assignment	7
1.3.2	Pin Function	9
Section 2	CPU.....	19
2.1	Register Configuration	19
2.1.1	Privileged Mode and Banks.....	19
2.1.2	General Registers	22
2.1.3	System Registers	23
2.1.4	Control Registers.....	23
2.2	Data Formats	25
2.2.1	Data Format in Registers.....	25
2.2.2	Data Format in Memory	25
2.3	Instruction Features	26
2.3.1	Execution Environment.....	26
2.3.2	Addressing Modes.....	28
2.3.3	Instruction Formats.....	32
2.4	Instruction Set.....	35
2.4.1	Instruction Set Classified by Function.....	35
2.4.2	Instruction Code Map.....	50
2.5	Processor States and Processor Modes.....	53
2.5.1	Processor States.....	53
2.5.2	Processor Modes	54
Section 3	Memory Management Unit (MMU).....	55
3.1	Overview	55
3.1.1	Features	55
3.1.2	Role of MMU	55
3.1.3	SH7709S MMU.....	58
3.1.4	Register Configuration	61
3.2	Register Description	61
3.3	TLB Functions.....	63
3.3.1	Configuration of the TLB.....	63
3.3.2	TLB Indexing.....	65
3.3.3	TLB Address Comparison.....	66
3.3.4	Page Management Information	68

3.4	MMU Functions	69
3.4.1	MMU Hardware Management	69
3.4.2	MMU Software Management	69
3.4.3	MMU Instruction (LDTLB)	70
3.4.4	Avoiding Synonym Problems	72
3.5	MMU Exceptions	74
3.5.1	TLB Miss Exception	74
3.5.2	TLB Protection Violation Exception	75
3.5.3	TLB Invalid Exception	76
3.5.4	Initial Page Write Exception	77
3.5.5	Processing Flow in Event of MMU Exception (Same Processing Flow for Address Error)	79
3.6	Configuration of Memory-Mapped TLB	80
3.6.1	Address Array	80
3.6.2	Data Array	81
3.6.3	Usage Examples	83
3.7	Usage Note	83
Section 4 Exception Handling		85
4.1	Overview	85
4.1.1	Features	85
4.1.2	Register Configuration	85
4.2	Exception Handling Function	85
4.2.1	Exception Handling Flow	85
4.2.2	Exception Vector Addresses	86
4.2.3	Acceptance of Exceptions	88
4.2.4	Exception Codes	90
4.2.5	Exception Request Masks	91
4.2.6	Returning from Exception Handling	91
4.3	Register Descriptions	92
4.4	Exception Handling Operation	93
4.4.1	Reset	93
4.4.2	Interrupts	93
4.4.3	General Exceptions	94
4.5	Individual Exception Operations	94
4.5.1	Resets	94
4.5.2	General Exceptions	95
4.5.3	Interrupts	99
4.6	Cautions	100
Section 5 Cache		103
5.1	Overview	103
5.1.1	Features	103

5.1.2	Cache Structure	103
5.1.3	Register Configuration	105
5.2	Register Description	105
5.2.1	Cache Control Register (CCR).....	105
5.2.2	Cache Control Register 2 (CCR2).....	106
5.3	Cache Operation	109
5.3.1	Searching the Cache	109
5.3.2	Read Access	111
5.3.3	Prefetch Operation.....	111
5.3.4	Write Access	111
5.3.5	Write-Back Buffer.....	111
5.3.6	Coherency of Cache and External Memory.....	112
5.4	Memory-Mapped Cache	112
5.4.1	Address Array	112
5.4.2	Data Array	113
5.4.3	Examples of Usage	115
Section 6 Interrupt Controller (INTC)		117
6.1	Overview	117
6.1.1	Features	117
6.1.2	Block Diagram	118
6.1.3	Pin Configuration	119
6.1.4	Register Configuration	120
6.2	Interrupt Sources	121
6.2.1	NMI Interrupt	121
6.2.2	IRQ Interrupts	121
6.2.3	IRL Interrupts.....	122
6.2.4	PINT Interrupts	124
6.2.5	On-Chip Peripheral Module Interrupts.....	124
6.2.6	Interrupt Exception Handling and Priority	125
6.3	INTC Registers.....	131
6.3.1	Interrupt Priority Registers A to E (IPRA–IPRE)	131
6.3.2	Interrupt Control Register 0 (ICR0)	132
6.3.3	Interrupt Control Register 1 (ICR1)	133
6.3.4	Interrupt Control Register 2 (ICR2)	136
6.3.5	PINT Interrupt Enable Register (PINTER)	137
6.3.6	Interrupt Request Register 0 (IRR0).....	138
6.3.7	Interrupt Request Register 1 (IRR1).....	140
6.3.8	Interrupt Request Register 2 (IRR2).....	141
6.4	INTC Operation.....	143
6.4.1	Interrupt Sequence.....	143
6.4.2	Multiple Interrupts.....	145
6.5	Interrupt Response Time	145

Section 7	User Break Controller.....	149
7.1	Overview	149
7.1.1	Features	149
7.1.2	Block Diagram	150
7.1.3	Register Configuration	151
7.2	Register Descriptions.....	152
7.2.1	Break Address Register A (BARA).....	152
7.2.2	Break Address Mask Register A (BAMRA)	153
7.2.3	Break Bus Cycle Register A (BBRA)	154
7.2.4	Break Address Register B (BARB).....	156
7.2.5	Break Address Mask Register B (BAMRB).....	157
7.2.6	Break Data Register B (BDRB)	158
7.2.7	Break Data Mask Register B (BDMRB)	159
7.2.8	Break Bus Cycle Register B (BBRB).....	160
7.2.9	Break Control Register (BRCR).....	162
7.2.10	Execution Times Break Register (BETR)	166
7.2.11	Branch Source Register (BRSR)	167
7.2.12	Branch Destination Register (BRDR)	168
7.2.13	Break ASID Register A (BASRA)	169
7.2.14	Break ASID Register B (BASRB)	169
7.3	Operation Description	170
7.3.1	Flow of the User Break Operation.....	170
7.3.2	Break on Instruction Fetch Cycle	170
7.3.3	Break by Data Access Cycle	171
7.3.4	Sequential Break	172
7.3.5	Value of Saved Program Counter	172
7.3.6	PC Trace.....	173
7.3.7	Usage Examples	174
7.3.8	Notes	179
Section 8	Power-Down Modes.....	181
8.1	Overview	181
8.1.1	Power-Down Modes.....	181
8.1.2	Pin Configuration	183
8.1.3	Register Configuration	183
8.2	Register Descriptions.....	183
8.2.1	Standby Control Register (STBCR)	183
8.2.2	Standby Control Register 2 (STBCR2)	185
8.3	Sleep Mode.....	187
8.3.1	Transition to Sleep Mode	187
8.3.2	Canceling Sleep Mode.....	187
8.3.3	Precautions when Using the Sleep Mode	187
8.4	Standby Mode.....	188

8.4.1	Transition to Standby Mode	188
8.4.2	Canceling Standby Mode	189
8.4.3	Clock Pause Function	190
8.5	Module Standby Function	191
8.5.1	Transition to Module Standby Function	191
8.5.2	Clearing Module Standby Function	191
8.6	Timing of STATUS Pin Changes	192
8.6.1	Timing for Resets	192
8.6.2	Timing for Canceling Standby	194
8.6.3	Timing for Canceling Sleep Mode	196
8.7	Hardware Standby Mode	199
8.7.1	Transition to Hardware Standby Mode	199
8.7.2	Canceling Hardware Standby Mode	199
8.7.3	Hardware Standby Mode Timing	200
Section 9 On-Chip Oscillation Circuits		203
9.1	Overview	203
9.1.1	Features	203
9.2	Overview of CPG	204
9.2.1	CPG Block Diagram	204
9.2.2	CPG Pin Configuration	206
9.2.3	CPG Register Configuration	206
9.3	Clock Operating Modes	207
9.4	Register Descriptions	211
9.4.1	Frequency Control Register (FRQCR)	211
9.5	Changing the Frequency	213
9.5.1	Changing the Multiplication Rate	213
9.5.2	Changing the Division Ratio	213
9.6	Overview of WDT	214
9.6.1	Block Diagram of WDT	214
9.6.2	Register Configuration	214
9.7	WDT Registers	215
9.7.1	Watchdog Timer Counter (WTCNT)	215
9.7.2	Watchdog Timer Control/Status Register (WTCSR)	215
9.7.3	Notes on Register Access	217
9.8	Using the WDT	218
9.8.1	Canceling Standby	218
9.8.2	Changing the Frequency	218
9.8.3	Using Watchdog Timer Mode	219
9.8.4	Using Interval Timer Mode	219
9.9	Notes on Board Design	220

Section 10	Bus State Controller (BSC)	223
10.1	Overview	223
10.1.1	Features	223
10.1.2	Block Diagram	225
10.1.3	Pin Configuration	226
10.1.4	Register Configuration	228
10.1.5	Area Overview	229
10.1.6	PCMCIA Support	232
10.2	BSC Registers	235
10.2.1	Bus Control Register 1 (BCR1)	235
10.2.2	Bus Control Register 2 (BCR2)	239
10.2.3	Wait State Control Register 1 (WCR1)	240
10.2.4	Wait State Control Register 2 (WCR2)	241
10.2.5	Individual Memory Control Register (MCR)	245
10.2.6	PCMCIA Control Register (PCR)	248
10.2.7	Synchronous DRAM Mode Register (SDMR)	252
10.2.8	Refresh Timer Control/Status Register (RTCSR)	253
10.2.9	Refresh Timer Counter (RTCNT)	255
10.2.10	Refresh Time Constant Register (RTCOR)	256
10.2.11	Refresh Count Register (RFCR)	256
10.2.12	Cautions on Accessing Refresh Control Related Registers	257
10.2.13	MCS0 Control Register (MCSCR0)	258
10.2.14	MCS1 Control Register (MCSCR1)	259
10.2.15	MCS2 Control Register (MCSCR2)	259
10.2.16	MCS3 Control Register (MCSCR3)	259
10.2.17	MCS4 Control Register (MCSCR4)	259
10.2.18	MCS5 Control Register (MCSCR5)	259
10.2.19	MCS6 Control Register (MCSCR6)	259
10.2.20	MCS7 Control Register (MCSCR7)	259
10.3	BSC Operation	260
10.3.1	Endian/Access Size and Data Alignment	260
10.3.2	Description of Areas	265
10.3.3	Basic Interface	268
10.3.4	Synchronous DRAM Interface	276
10.3.5	Burst ROM Interface	304
10.3.6	PCMCIA Interface	307
10.3.7	Waits between Access Cycles	319
10.3.8	Bus Arbitration	320
10.3.9	Bus Pull-Up	321
10.3.10	MCS[0] to MCS[7] Pin Control	323
Section 11	Direct Memory Access Controller (DMAC)	327
11.1	Overview	327

11.1.1	Features	327
11.1.2	Block Diagram	329
11.1.3	Pin Configuration	330
11.1.4	Register Configuration	331
11.2	Register Descriptions.....	333
11.2.1	DMA Source Address Registers 0–3 (SAR0–SAR3).....	333
11.2.2	DMA Destination Address Registers 0–3 (DAR0–DAR3)	334
11.2.3	DMA Transfer Count Registers 0–3 (DMATCR0–DMATCR3).....	335
11.2.4	DMA Channel Control Registers 0–3 (CHCR0–CHCR3)	336
11.2.5	DMA Operation Register (DMAOR).....	343
11.3	Operation.....	345
11.3.1	DMA Transfer Flow	345
11.3.2	DMA Transfer Requests.....	347
11.3.3	Channel Priority	349
11.3.4	DMA Transfer Types	352
11.3.5	Number of Bus Cycle States and DREQ Pin Sampling Timing.....	363
11.3.6	Source Address Reload Function	372
11.3.7	DMA Transfer Ending Conditions	374
11.4	Compare Match Timer (CMT)	376
11.4.1	Overview	376
11.4.2	Register Descriptions	377
11.4.3	Operation.....	380
11.4.4	Compare Match	381
11.5	Examples of Use.....	383
11.5.1	Example of DMA Transfer between On-Chip IrDA and External Memory	383
11.5.2	Example of DMA Transfer between A/D Converter and External Memory	384
11.5.3	Example of DMA Transfer between External Memory and SCIF Transmitter (Indirect Address On).....	385
11.6	Usage Notes.....	387
Section 12 Timer (TMU).....		389
12.1	Overview	389
12.1.1	Features	389
12.1.2	Block Diagram	390
12.1.3	Pin Configuration	391
12.1.4	Register Configuration	391
12.2	TMU Registers	392
12.2.1	Timer Output Control Register (TOCR)	392
12.2.2	Timer Start Register (TSTR).....	392
12.2.3	Timer Control Registers (TCR).....	393
12.2.4	Timer Constant Registers (TCOR).....	397
12.2.5	Timer Counters (TCNT).....	397
12.2.6	Input Capture Register (TCPR2).....	399

12.3	TMU Operation	400
12.3.1	General Operation	400
12.3.2	Input Capture Function.....	403
12.4	Interrupts	404
12.4.1	Status Flag Setting Timing	404
12.4.2	Status Flag Clearing Timing.....	405
12.4.3	Interrupt Sources and Priorities	405
12.5	Usage Notes.....	406
12.5.1	Writing to Registers.....	406
12.5.2	Reading Registers.....	406
Section 13 Realtime Clock (RTC)		407
13.1	Overview	407
13.1.1	Features	407
13.1.2	Block Diagram	408
13.1.3	Pin Configuration	409
13.1.4	RTC Register Configuration.....	410
13.2	RTC Registers	411
13.2.1	64-Hz Counter (R64CNT).....	411
13.2.2	Second Counter (RSECCNT).....	411
13.2.3	Minute Counter (RMINCNT)	412
13.2.4	Hour Counter (RHRCNT).....	412
13.2.5	Day of Week Counter (RWKCNT).....	413
13.2.6	Date Counter (RDAYCNT).....	414
13.2.7	Month Counter (RMONCNT).....	414
13.2.8	Year Counter (RYRCNT)	415
13.2.9	Second Alarm Register (RSECAR).....	415
13.2.10	Minute Alarm Register (RMINAR)	416
13.2.11	Hour Alarm Register (RHRAR).....	416
13.2.12	Day of Week Alarm Register (RWKAR).....	417
13.2.13	Date Alarm Register (RDAYAR)	418
13.2.14	Month Alarm Register (RMONAR).....	418
13.2.15	RTC Control Register 1 (RCR1)	419
13.2.16	RTC Control Register 2 (RCR2)	420
13.3	RTC Operation	422
13.3.1	Initial Settings of Registers after Power-On.....	422
13.3.2	Setting the Time	422
13.3.3	Reading the Time	423
13.3.4	Alarm Function	424
13.3.5	Crystal Oscillator Circuit.....	425
13.4	Usage Notes.....	426
13.4.1	Register Writing during RTC Count	426
13.4.2	Use of Realtime Clock (RTC) Periodic Interrupts	426

13.4.3	Precautions when Using RTC Module Standby	426
Section 14	Serial Communication Interface (SCI)	427
14.1	Overview	427
14.1.1	Features	427
14.1.2	Block Diagram	428
14.1.3	Pin Configuration	431
14.1.4	Register Configuration	432
14.2	Register Descriptions.....	432
14.2.1	Receive Shift Register (SCRSR)	432
14.2.2	Receive Data Register (SCRDR).....	433
14.2.3	Transmit Shift Register (SCTSR).....	433
14.2.4	Transmit Data Register (SCTDR)	434
14.2.5	Serial Mode Register (SCSMR)	434
14.2.6	Serial Control Register (SCSCR)	437
14.2.7	Serial Status Register (SCSSR)	440
14.2.8	SC Port Control Register (SCPCR)/SC Port Data Register (SCPDR)	444
14.2.9	Bit Rate Register (SCBRR).....	446
14.3	Operation.....	453
14.3.1	Overview	453
14.3.2	Operation in Asynchronous Mode.....	455
14.3.3	Multiprocessor Communication	465
14.3.4	Synchronous Operation	474
14.4	SCI Interrupts	484
14.5	Usage Notes.....	485
Section 15	Smart Card Interface.....	489
15.1	Overview	489
15.1.1	Features	489
15.1.2	Block Diagram	490
15.1.3	Pin Configuration	491
15.1.4	Smart Card Interface Registers.....	491
15.2	Register Descriptions.....	492
15.2.1	Smart Card Mode Register (SCSCMR).....	492
15.2.2	Serial Status Register (SCSSR)	493
15.3	Operation.....	494
15.3.1	Overview	494
15.3.2	Pin Connections.....	495
15.3.3	Data Format.....	496
15.3.4	Register Settings.....	497
15.3.5	Clock	498
15.3.6	Data Transmission and Reception	501
15.4	Usage Notes.....	507

15.4.1	Receive Data Timing and Receive Margin in Asynchronous Mode	507
15.4.2	Retransmission (Receive and Transmit Modes).....	509
Section 16 Serial Communication Interface with FIFO (SCIF)		511
16.1	Overview	511
16.1.1	Features	511
16.1.2	Block Diagram	512
16.1.3	Pin Configuration	515
16.1.4	Register Configuration	516
16.2	Register Descriptions.....	517
16.2.1	Receive Shift Register (SCRSR).....	517
16.2.2	Receive FIFO Data Register (SCFRDR).....	517
16.2.3	Transmit Shift Register (SCTSR).....	517
16.2.4	Transmit FIFO Data Register (SCFTDR)	518
16.2.5	Serial Mode Register (SCSMR)	518
16.2.6	Serial Control Register (SCSCR)	520
16.2.7	Serial Status Register (SCSSR).....	522
16.2.8	Bit Rate Register (SCBRR).....	527
16.2.9	FIFO Control Register (SCFCR).....	534
16.2.10	FIFO Data Count Register (SCFDR)	536
16.3	Operation.....	537
16.3.1	Overview	537
16.3.2	Serial Operation.....	538
16.4	SCIF Interrupts	550
16.5	Usage Notes.....	551
Section 17 IrDA.....		555
17.1	Overview	555
17.1.1	Features	555
17.1.2	Block Diagram	556
17.1.3	Pin Configuration	559
17.1.4	Register Configuration	560
17.2	Register Description	561
17.2.1	Serial Mode Register (SCSMR).....	561
17.3	Operation Description	563
17.3.1	Overview	563
17.3.2	Transmitting	563
17.3.3	Receiving.....	564
Section 18 Pin Function Controller		565
18.1	Overview	565
18.2	Register Configuration	569
18.3	Register Descriptions.....	570

18.3.1	Port A Control Register (PACR)	570
18.3.2	Port B Control Register (PBCR)	571
18.3.3	Port C Control Register (PCCR)	572
18.3.4	Port D Control Register (PDCR)	573
18.3.5	Port E Control Register (PECR)	574
18.3.6	Port F Control Register (PFCR)	575
18.3.7	Port G Control Register (PGCR)	576
18.3.8	Port H Control Register (PHCR)	577
18.3.9	Port J Control Register (PJCR)	579
18.3.10	Port K Control Register (PKCR)	580
18.3.11	Port L Control Register (PLCR)	581
18.3.12	SC Port Control Register (SCPCR)	582
Section 19 I/O Ports		587
19.1	Overview	587
19.2	Port A	587
19.2.1	Register Description	587
19.2.2	Port A Data Register (PADR)	588
19.3	Port B	589
19.3.1	Register Description	589
19.3.2	Port B Data Register (PBDR)	590
19.4	Port C	591
19.4.1	Register Description	591
19.4.2	Port C Data Register (PCDR)	592
19.5	Port D	593
19.5.1	Register Description	593
19.5.2	Port D Data Register (PDDR)	594
19.6	Port E	595
19.6.1	Register Description	595
19.6.2	Port E Data Register (PEDR)	596
19.7	Port F	597
19.7.1	Register Description	597
19.7.2	Port F Data Register (PFDR)	598
19.8	Port G	599
19.8.1	Register Description	599
19.8.2	Port G Data Register (PGDR)	600
19.9	Port H	601
19.9.1	Register Description	601
19.9.2	Port H Data Register (PHDR)	602
19.10	Port J	603
19.10.1	Register Description	603
19.10.2	Port J Data Register (PJDR)	604
19.11	Port K	605

19.11.1 Register Description	605
19.11.2 Port K Data Register (PKDR)	606
19.12 Port L.....	607
19.12.1 Register Description	607
19.12.2 Port L Data Register (PLDR)	608
19.13 SC Port	609
19.13.1 Register Description	609
19.13.2 SC Port Data Register (SCPDR)	610
Section 20 A/D Converter	613
20.1 Overview	613
20.1.1 Features	613
20.1.2 Block Diagram	614
20.1.3 Input Pins.....	615
20.1.4 Register Configuration	616
20.2 Register Descriptions.....	617
20.2.1 A/D Data Registers A to D (ADDRA to ADDR D)	617
20.2.2 A/D Control/Status Register (ADCSR).....	618
20.2.3 A/D Control Register (ADCR).....	621
20.3 Bus Master Interface.....	622
20.4 Operation.....	623
20.4.1 Single Mode (MULTI = 0).....	623
20.4.2 Multi Mode (MULTI = 1, SCN = 0)	625
20.4.3 Scan Mode (MULTI = 1, SCN = 1)	627
20.4.4 Input Sampling and A/D Conversion Time	629
20.4.5 External Trigger Input Timing	630
20.5 Interrupts	631
20.6 Definitions of A/D Conversion Accuracy	631
20.7 Usage Notes.....	632
20.7.1 Setting Analog Input Voltage	632
20.7.2 Processing of Analog Input Pins	632
20.7.3 Access Size and Read Data	633
Section 21 D/A Converter	635
21.1 Overview	635
21.1.1 Features	635
21.1.2 Block Diagram	635
21.1.3 I/O Pins.....	636
21.1.4 Register Configuration	636
21.2 Register Descriptions.....	637
21.2.1 D/A Data Registers 0 and 1 (DADR0/1)	637
21.2.2 D/A Control Register (DACR).....	637
21.3 Operation.....	639

Section 22	User Debugging Interface (UDI)	641
22.1	Overview	641
22.2	User Debugging Interface (UDI)	641
22.2.1	Pin Descriptions	641
22.2.2	Block Diagram	642
22.3	Register Descriptions	642
22.3.1	Bypass Register (SDBPR)	643
22.3.2	Instruction Register (SDIR)	643
22.3.3	Boundary Scan Register (SDBSR)	644
22.4	UDI Operation	651
22.4.1	TAP Controller	651
22.4.2	Reset Configuration	652
22.4.3	UDI Reset	653
22.4.4	UDI Interrupt	653
22.4.5	Bypass	653
22.4.6	Using UDI to Recover from Sleep Mode	653
22.5	Boundary Scan	654
22.5.1	Supported Instructions	654
22.5.2	Points for Attention	655
22.6	Usage Notes	655
22.7	Advanced User Debugger (AUD)	655
Section 23	Electrical Characteristics	657
23.1	Absolute Maximum Ratings	657
23.2	DC Characteristics	659
23.3	AC Characteristics	663
23.3.1	Clock Timing	664
23.3.2	Control Signal Timing	670
23.3.3	AC Bus Timing	673
23.3.4	Basic Timing	675
23.3.5	Burst ROM Timing	678
23.3.6	Synchronous DRAM Timing	681
23.3.7	PCMCIA Timing	699
23.3.8	Peripheral Module Signal Timing	706
23.3.9	UDI-Related Pin Timing	709
23.3.10	AC Characteristics Measurement Conditions	711
23.3.11	Delay Time Variation Due to Load Capacitance	712
23.4	A/D Converter Characteristics	713
23.5	D/A Converter Characteristics	713
Appendix A	Pin Functions	715
A.1	Pin States	715
A.2	Pin Specifications	719

A.3	Treatment of Unused Pins	724
A.4	Pin States in Access to Each Address Space	725
Appendix B Memory-Mapped Control Registers.....		739
B.1	Register Address Map	739
B.2	Register Bits	745
Appendix C Product Lineup.....		757
Appendix D Package Dimensions.....		758

Figures

Figure 1.1	Block Diagram	6
Figure 1.2	Pin Assignment (FP-208C, FP-208E)	7
Figure 1.3	Pin Assignment (BP-240A).....	8
Figure 2.1	User Mode Register Configuration	20
Figure 2.2	Privileged Mode Register Configuration.....	21
Figure 2.3	General Registers	22
Figure 2.4	System Registers	23
Figure 2.5	Register Set Overview, Control Registers	24
Figure 2.6	Longword	25
Figure 2.7	Data Format in Memory	25
Figure 2.8	Processor State Transitions.....	54
Figure 3.1	MMU Functions	57
Figure 3.2	Virtual Address Space Mapping.....	59
Figure 3.3	MMU Register Contents	62
Figure 3.4	Overall Configuration of the TLB	63
Figure 3.5	Virtual Address and TLB Structure.....	64
Figure 3.6	TLB Indexing (IX = 1)	65
Figure 3.7	TLB Indexing (IX = 0).....	66
Figure 3.8	Objects of Address Comparison	67
Figure 3.9	Operation of LDTLB Instruction.....	71
Figure 3.10	Synonym Problem	73
Figure 3.11	MMU Exception Generation Flowchart	78
Figure 3.12	MMU Exception Signals in Instruction Fetch	79
Figure 3.13	MMU Exception Signals in Data Access	80
Figure 3.14	Specifying Address and Data for Memory-Mapped TLB Access	82
Figure 4.1	Vector Table.....	86
Figure 4.2	Example of Acceptance Order of General Exceptions	89
Figure 4.3	Bit Configurations of EXPEVT, INTEVT, INTEVT2, and TRA Registers.....	92
Figure 5.1	Cache Structure	104
Figure 5.2	CCR Register Configuration	106
Figure 5.3	CCR2 Register Configuration	107
Figure 5.4	Cache Search Scheme (Normal Mode)	110
Figure 5.5	Write-Back Buffer Configuration.....	112
Figure 5.6	Specifying Address and Data for Memory-Mapped Cache Access.....	114
Figure 6.1	Block Diagram of INTC.....	118
Figure 6.2	Example of IRL Interrupt Connection.....	122
Figure 6.3	Interrupt Operation Flowchart.....	144
Figure 6.4	Example of Pipeline Operations when IRL Interrupt is Accepted	148
Figure 7.1	Block Diagram of User Break Controller.....	150
Figure 8.1	Canceling Standby Mode with STBCR.STBY.....	189
Figure 8.2	Power-On Reset (Clock Modes 0, 1, 2, and 7) STATUS Output	192

Figure 8.3	Manual Reset STATUS Output.....	193
Figure 8.4	Standby to Interrupt STATUS Output.....	194
Figure 8.5	Standby to Power-On Reset STATUS Output.....	195
Figure 8.6	Standby to Manual Reset STATUS Output.....	196
Figure 8.7	Sleep to Interrupt STATUS Output.....	196
Figure 8.8	Sleep to Power-On Reset STATUS Output.....	197
Figure 8.9	Sleep to Manual Reset STATUS Output.....	198
Figure 8.10	Hardware Standby Mode (When CA Goes Low in Normal Operation).....	200
Figure 8.11	Hardware Standby Mode Timing (When CA Goes Low during WDT Operation on Standby Mode Cancellation).....	201
Figure 9.1	Block Diagram of Clock Pulse Generator.....	204
Figure 9.2	Block Diagram of WDT.....	214
Figure 9.3	Writing to WTCNT and WTCSR.....	217
Figure 9.4	Points for Attention when Using Crystal Resonator.....	220
Figure 9.5	Points for Attention when Using PLL Oscillator Circuit.....	221
Figure 10.1	Block Diagram of Bus State Controller.....	225
Figure 10.2	Correspondence between Logical Address Space and Physical Address Space ..	229
Figure 10.3	Physical Space Allocation.....	231
Figure 10.4	PCMCIA Space Allocation.....	232
Figure 10.5	Writing to RFCR, RTCSR, RTCNT, and RTCOR.....	257
Figure 10.6	Basic Timing of Basic Interface.....	269
Figure 10.7	Example of 32-Bit Data-Width Static RAM Connection.....	270
Figure 10.8	Example of 16-Bit Data-Width Static RAM Connection.....	271
Figure 10.9	Example of 8-Bit Data-Width Static RAM Connection.....	272
Figure 10.10	Basic Interface Wait Timing (Software Wait Only).....	273
Figure 10.11	Basic Interface Wait State Timing (Wait State Insertion by $\overline{\text{WAIT}}$ Signal WAITSEL = 1).....	275
Figure 10.12	Example of 64-Mbit Synchronous DRAM Connection (32-Bit Bus Width).....	277
Figure 10.13	Example of 64-Mbit Synchronous DRAM Connection (16-Bit Bus Width).....	278
Figure 10.14	Basic Timing for Synchronous DRAM Burst Read.....	282
Figure 10.15	Synchronous DRAM Burst Read Wait Specification Timing.....	283
Figure 10.16	Basic Timing for Synchronous DRAM Single Read.....	284
Figure 10.17	Basic Timing for Synchronous DRAM Burst Write.....	286
Figure 10.18	Basic Timing for Synchronous DRAM Single Write.....	288
Figure 10.19	Burst Read Timing (No Precharge).....	291
Figure 10.20	Burst Read Timing (Same Row Address).....	292
Figure 10.21	Burst Read Timing (Different Row Addresses).....	293
Figure 10.22	Burst Write Timing (No Precharge).....	294
Figure 10.23	Burst Write Timing (Same Row Address).....	295
Figure 10.24	Burst Write Timing (Different Row Addresses).....	296
Figure 10.25	Auto-Refresh Operation.....	298
Figure 10.26	Synchronous DRAM Auto-Refresh Timing.....	299
Figure 10.27	Synchronous DRAM Self-Refresh Timing.....	301

Figure 10.28	Synchronous DRAM Mode Write Timing	303
Figure 10.29	Burst ROM Wait Access Timing	305
Figure 10.30	Burst ROM Basic Access Timing	306
Figure 10.31	Example of PCMCIA Interface	308
Figure 10.32	Basic Timing for PCMCIA Memory Card Interface	310
Figure 10.33	Wait Timing for PCMCIA Memory Card Interface	311
Figure 10.34	Basic Timing for PCMCIA Memory Card Interface Burst Access	312
Figure 10.35	Wait Timing for PCMCIA Memory Card Interface Burst Access	313
Figure 10.36	PCMCIA Space Allocation	314
Figure 10.37	Basic Timing for PCMCIA I/O Card Interface	316
Figure 10.38	Wait Timing for PCMCIA I/O Card Interface	317
Figure 10.39	Dynamic Bus Sizing Timing for PCMCIA I/O Card Interface	318
Figure 10.40	Waits between Access Cycles	320
Figure 10.41	Pull-Up Timing for Pins A25 to A0	321
Figure 10.42	Pull-Up Timing for Pins D31 to D0 (Read Cycle)	322
Figure 10.43	Pull-Up Timing for Pins D31 to D0 (Write Cycle)	322
Figure 11.1	Block Diagram of DMAC	329
Figure 11.2	DMAC Transfer Flowchart	346
Figure 11.3	Round-Robin Mode.....	350
Figure 11.4	Changes in Channel Priority in Round-Robin Mode.....	351
Figure 11.5	Operation of Direct Address Mode in Dual Address Mode	353
Figure 11.6	Example of DMA Transfer Timing in the Direct Address Mode in Dual Mode (Transfer Source: Ordinary Memory, Transfer Destination: Ordinary Memory).	354
Figure 11.7	Indirect Address Operation in Dual Address Mode (When External Memory Space has a 16-Bit Width).....	355
Figure 11.8	Example of Transfer Timing in the Indirect Address Mode in Dual Address Mode	356
Figure 11.9	Data Flow in Single Address Mode.....	357
Figure 11.10	Example of DMA Transfer Timing in Single Address Mode	358
Figure 11.11	Example of DMA Transfer Timing in Single Address Mode (16-byte Transfer, External Memory Space (Ordinary Memory) → External Device with DACK)	359
Figure 11.12	Example of DMA Transfer in Cycle-Steal Mode.....	360
Figure 11.13	Example of Transfer in Burst Mode	360
Figure 11.14	Bus State when Multiple Channels Are Operating	362
Figure 11.15	Cycle-Steal Mode, Level Input (CPU Access: 2 Cycles)	365
Figure 11.16	Cycle-Steal Mode, Level Input (CPU Access: 3 Cycles)	366
Figure 11.17	Cycle-Steal Mode, Level input (CPU Access: 2 Cycles, DMA RD Access: 4 Cycles).....	367
Figure 11.18	Cycle-Steal Mode, Level input (CPU Access: 2 Cycles, \overline{DREQ} Input Delayed).	368
Figure 11.19	Cycle-Steal Mode, Edge input (CPU Access: 2 Cycles)	369
Figure 11.20	Burst Mode, Level Input	370
Figure 11.21	Burst Mode, Edge Input	371
Figure 11.22	Source Address Reload Function Diagram.....	372

Figure 11.23	Timing Chart of Source Address Reload Function.....	373
Figure 11.24	Block Diagram of CMT	376
Figure 11.25	Counter Operation	380
Figure 11.26	Count Timing	381
Figure 11.27	CMF Setting Timing	382
Figure 11.28	Timing of CMF Clearing by the CPU	382
Figure 12.1	Block Diagram of TMU	390
Figure 12.2	Setting the Count Operation	401
Figure 12.3	Auto-Reload Count Operation.....	402
Figure 12.4	Count Timing when Operating on Internal Clock	402
Figure 12.5	Count Timing when Operating on External Clock (Both Edges Detected)	403
Figure 12.6	Count Timing when Operating on On-Chip RTC Clock.....	403
Figure 12.7	Operation Timing when Using Input Capture Function (Using TCLK Rising Edge)	404
Figure 12.8	UNF Setting Timing.....	404
Figure 12.9	Status Flag Clearing Timing.....	405
Figure 13.1	Block Diagram of RTC	408
Figure 13.2	Setting the Time	422
Figure 13.3	Reading the Time	423
Figure 13.4	Using the Alarm Function	424
Figure 13.5	Example of Crystal Oscillator Circuit Connection.....	425
Figure 13.6	Using Periodic Interrupt Function	426
Figure 14.1	Block Diagram of SCI.....	428
Figure 14.2	SCPT[1]/SCK0 Pin	429
Figure 14.3	SCPT[0]/TxD0 Pin.....	430
Figure 14.4	SCPT[0]/RxD0 Pin.....	431
Figure 14.5	Example of Data Format in Asynchronous Communication (8-Bit Data with Parity and Two Stop Bits)	455
Figure 14.6	Output Clock and Serial Data Timing (Asynchronous Mode)	457
Figure 14.7	Sample Flowchart for SCI Initialization.....	458
Figure 14.8	Sample Flowchart for Transmitting Serial Data	459
Figure 14.9	Example of SCI Transmit Operation in Asynchronous Mode (8-Bit Data with Parity and One Stop Bit)	461
Figure 14.10	Sample Flowchart for Receiving Serial Data	462
Figure 14.11	Example of SCI Receive Operation (8-Bit Data with Parity and One Stop Bit) ..	465
Figure 14.12	Communication Among Processors Using Multiprocessor Format (Sending Data H'AA to Receiving Processor A).....	466
Figure 14.13	Sample Flowchart for Transmitting Multiprocessor Serial Data.....	467
Figure 14.14	Example of SCI Multiprocessor Transmit Operation (8-Bit Data with Multiprocessor Bit and One Stop Bit).....	468
Figure 14.15	Sample Flowchart for Receiving Multiprocessor Serial Data	470
Figure 14.16	Example of SCI Receive Operation (8-Bit Data with Multiprocessor Bit and One Stop Bit).....	472

Figure 14.17	Data Format in Synchronous Communication	474
Figure 14.18	Sample Flowchart for SCI Initialization.....	476
Figure 14.19	Sample Flowchart for Transmitting Serial Data.....	477
Figure 14.20	Example of SCI Transmit Operation.....	478
Figure 14.21	Sample Flowchart for Receiving Serial Data	480
Figure 14.22	Example of SCI Receive Operation.....	482
Figure 14.23	Sample Flowchart for Transmitting/Receiving Serial Data.....	483
Figure 14.24	Receive Data Sampling Timing in Asynchronous Mode	486
Figure 15.1	Block Diagram of Smart Card Interface.....	490
Figure 15.2	Pin Connection Diagram for Smart Card Interface	495
Figure 15.3	Data Format for Smart Card Interface.....	496
Figure 15.4	Waveform of Start Character.....	498
Figure 15.5	Initialization Flowchart (Example).....	502
Figure 15.6	Transmission Flowchart	504
Figure 15.7	Reception Flowchart (Example).....	506
Figure 15.8	Receive Data Sampling Timing in Smart Card Mode	508
Figure 15.9	Retransmission in SCI Receive Mode	509
Figure 15.10	Retransmission in SCI Transmit Mode	510
Figure 16.1	Block Diagram of SCIF.....	512
Figure 16.2	SCPT[5]/SCK2 Pin	513
Figure 16.3	SCPT[4]/TxD2 Pin.....	514
Figure 16.4	SCPT[4]/RxD2 Pin.....	515
Figure 16.5	Sample Flowchart for SCIF Initialization	540
Figure 16.6	Sample Flowchart for Transmitting Serial Data.....	542
Figure 16.7	Example of Transmit Operation (8-Bit Data, Parity, One Stop Bit).....	544
Figure 16.8	Example of Operation Using Modem Control ($\overline{\text{CTS}}$).....	544
Figure 16.9	Sample Flowchart for Receiving Serial Data	546
Figure 16.10	Sample Flowchart for Receiving Serial Data (cont).....	547
Figure 16.11	Example of SCIF Receive Operation (8-Bit Data, Parity, One Stop Bit).....	549
Figure 16.12	Example of Operation Using Modem Control ($\overline{\text{RTS}}$).....	549
Figure 16.13	Receive Data Sampling Timing in Asynchronous Mode	552
Figure 17.1	Block Diagram of IrDA.....	556
Figure 17.2	SCPT[3]/SCK1 Pin	557
Figure 17.3	SCPT[2]/TxD1 Pin.....	558
Figure 17.4	SCPT[2]/RxD1 Pin.....	559
Figure 17.5	Transmit/Receive Operation.....	564
Figure 19.1	Port A	587
Figure 19.2	Port B	589
Figure 19.3	Port C	591
Figure 19.4	Port D	593
Figure 19.5	Port E.....	595
Figure 19.6	Port F.....	597
Figure 19.7	Port G	599

Figure 19.8	Port H	601
Figure 19.9	Port J	603
Figure 19.10	Port K	605
Figure 19.11	Port L.....	607
Figure 19.12	SC Port	609
Figure 20.1	Block Diagram of A/D Converter	614
Figure 20.2	A/D Data Register Access Operation (Reading H'AA40).....	622
Figure 20.3	Example of A/D Converter Operation (Single Mode, Channel 1 Selected)	624
Figure 20.4	Example of A/D Converter Operation (Multi Mode, Channels AN0 to AN2 Selected).....	626
Figure 20.5	Example of A/D Converter Operation (Scan Mode, Channels AN0 to AN2 Selected).....	628
Figure 20.6	A/D Conversion Timing	629
Figure 20.7	External Trigger Input Timing	630
Figure 20.8	Definitions of A/D Conversion Accuracy	632
Figure 20.9	Example of Analog Input Protection Circuit.....	633
Figure 20.10	Analog Input Pin Equivalent Circuit	633
Figure 21.1	Block Diagram of D/A Converter	635
Figure 21.2	Example of D/A Converter Operation.....	639
Figure 22.1	Block Diagram of UDI.....	642
Figure 22.2	TAP Controller State Transitions	651
Figure 22.3	UDI Reset.....	653
Figure 23.1	EXTAL Clock Input Timing	665
Figure 23.2	CKIO Clock Input Timing	665
Figure 23.3	CKIO Clock Output Timing.....	665
Figure 23.4	Power-on Oscillation Settling Time	666
Figure 23.5	Oscillation Settling Time at Standby Return (Return by Reset).....	666
Figure 23.6	Oscillation Settling Time at Standby Return (Return by NMI).....	667
Figure 23.7	Oscillation Settling Time at Standby Return (Return by IRQ4 to IRQ0, PINT0/1, $\overline{\text{IRL3}}$ to $\overline{\text{IRL0}}$).....	667
Figure 23.8	PLL Synchronization Settling Time during Standby Recovery (Reset or NMI)..	668
Figure 23.9	PLL Synchronization Settling Time during Standby Recovery (IRQ/IRL or PINT0/PINT1 Interrupt).....	668
Figure 23.10	PLL Synchronization Settling Time when Frequency Multiplication Rate Modified.....	669
Figure 23.11	Reset Input Timing.....	671
Figure 23.12	Interrupt Signal Input Timing.....	671
Figure 23.13	$\overline{\text{IRQOUT}}$ Timing	671
Figure 23.14	Bus Release Timing.....	672
Figure 23.15	Pin Drive Timing at Standby	672
Figure 23.16	Basic Bus Cycle (No Wait)	675
Figure 23.17	Basic Bus Cycle (One Wait).....	676
Figure 23.18	Basic Bus Cycle (External Wait, WAITSEL = 1)	677

Figure 23.19	Burst ROM Bus Cycle (No Wait)	678
Figure 23.20	Burst ROM Bus Cycle (Two Waits)	679
Figure 23.21	Burst ROM Bus Cycle (External Wait, WAITSEL = 1)	680
Figure 23.22	Synchronous DRAM Read Bus Cycle (RCD = 0, CAS Latency = 1, TPC = 0) ..	681
Figure 23.23	Synchronous DRAM Read Bus Cycle (RCD = 2, CAS Latency = 2, TPC = 1) ..	682
Figure 23.24	Synchronous DRAM Read Bus Cycle (Burst Read (Single Read × 4), RCD = 0, CAS Latency = 1, TPC = 1)	683
Figure 23.25	Synchronous DRAM Read Bus Cycle (Burst Read (Single Read × 4), RCD = 1, CAS Latency = 3, TPC = 0)	684
Figure 23.26	Synchronous DRAM Write Bus Cycle (RCD = 0, TPC = 0, TRWL = 0)	685
Figure 23.27	Synchronous DRAM Write Bus Cycle (RCD = 2, TPC = 1, TRWL = 1)	686
Figure 23.28	Synchronous DRAM Write Bus Cycle (Burst Mode (Single Write × 4), RCD = 0, TPC = 1, TRWL = 0)	687
Figure 23.29	Synchronous DRAM Write Bus Cycle (Burst Mode (Single Write × 4), RCD = 1, TPC = 0, TRWL = 0)	688
Figure 23.30	Synchronous DRAM Burst Read Bus Cycle (RAS Down, Same Row Address, CAS Latency = 1)	689
Figure 23.31	Synchronous DRAM Burst Read Bus Cycle (RAS Down, Same Row Address, CAS Latency = 2)	690
Figure 23.32	Synchronous DRAM Burst Read Bus Cycle (RAS Down, Different Row Address, TPC = 0, RCD = 0, CAS Latency = 1)	691
Figure 23.33	Synchronous DRAM Burst Read Bus Cycle (RAS Down, Different Row Address, TPC = 1, RCD = 0, CAS Latency = 1)	692
Figure 23.34	Synchronous DRAM Burst Write Bus Cycle (RAS Down, Same Row Address)	693
Figure 23.35	Synchronous DRAM Burst Write Bus Cycle (RAS Down, Different Row Address, TPC = 0, RCD = 0)	694
Figure 23.36	Synchronous DRAM Burst Write Bus Cycle (RAS Down, Different Row Address, TPC = 1, RCD = 1)	695
Figure 23.37	Synchronous DRAM Auto-Refresh Timing (TRAS = 1, TPC = 1)	696
Figure 23.38	Synchronous DRAM Self-Refresh Cycle (TRAS = 1, TPC = 1)	697
Figure 23.39	Synchronous DRAM Mode Register Write Cycle	698
Figure 23.40	PCMCIA Memory Bus Cycle (TED = 0, TEH = 0, No Wait)	699
Figure 23.41	PCMCIA Memory Bus Cycle (TED = 2, TEH = 1, One Wait, External Wait, WAITSEL = 1)	700
Figure 23.42	PCMCIA Memory Bus Cycle (Burst Read, TED = 0, TEH = 0, No Wait)	701
Figure 23.43	PCMCIA Memory Bus Cycle (Burst Read, TED = 1, TEH = 1, Two Waits, Burst Pitch = 3, WAITSEL = 1)	702
Figure 23.44	PCMCIA I/O Bus Cycle (TED = 0, TEH = 0, No Wait)	703
Figure 23.45	PCMCIA I/O Bus Cycle (TED = 2, TEH = 1, One Wait, External Wait, WAITSEL = 1)	704
Figure 23.46	PCMCIA I/O Bus Cycle (TED = 1, TEH = 1, One Wait, Bus Sizing, WAITSEL = 1)	705

Figure 23.47	TCLK Input Timing	707
Figure 23.48	TCLK Clock Input Timing	707
Figure 23.49	Oscillation Settling Time at RTC Crystal Oscillator Power-on.....	707
Figure 23.50	SCK Input Clock Timing	707
Figure 23.51	SCI I/O Timing in Clock Synchronous Mode	708
Figure 23.52	I/O Port Timing	708
Figure 23.53	$\overline{\text{DREQ}}$ Input Timing	708
Figure 23.54	DRAK Output Timing.....	709
Figure 23.55	TCK Input Timing.....	709
Figure 23.56	$\overline{\text{TRST}}$ Input Timing (Reset Hold).....	710
Figure 23.57	UDI Data Transfer Timing.....	710
Figure 23.58	$\overline{\text{ASEMD0}}$ Input Timing.....	710
Figure 23.59	Output Load Circuit.....	711
Figure 23.60	Load Capacitance vs. Delay Time.....	712
Figure D.1	Package Dimensions (FP-208C).....	758
Figure D.2	Package Dimensions (FP-208E).....	759
Figure D.3	Package Dimensions (BP-240A).....	760

Tables

Table 1.1	SH7709S Features	2
Table 1.2	Characteristics.....	5
Table 1.3	SH7709S Pin Function	9
Table 2.1	Initial Register Values	22
Table 2.2	Addressing Modes and Effective Addresses.....	28
Table 2.3	Instruction Formats	32
Table 2.4	Classification of Instructions	35
Table 2.5	Instruction Code Format	38
Table 2.6	Data Transfer Instructions	39
Table 2.7	Arithmetic Instructions	41
Table 2.8	Logic Operation Instructions	44
Table 2.9	Shift Instructions.....	45
Table 2.10	Branch Instructions.....	46
Table 2.11	System Control Instructions.....	47
Table 2.12	Instruction Code Map	50
Table 3.1	Register Configuration.....	61
Table 3.2	Access States Designated by D, C, and PR Bits	68
Table 4.1	Register Configuration.....	85
Table 4.2	Exception Event Vectors	87
Table 4.3	Exception Codes	90
Table 4.4	Types of Reset	95
Table 5.1	Cache Specifications.....	103
Table 5.2	LRU and Way Replacement (When the cache lock function is not used)	105
Table 5.3	Register Configuration.....	105
Table 5.4	Way Replacement when PREF Instruction Ended Up in a Cache Miss	107
Table 5.5	Way Replacement when Instructions Except for PREF Instruction Ended Up in a Cache Miss.....	108
Table 5.6	LRU and Way Replacement (when W2LOCK=1)	108
Table 5.7	LRU and Way Replacement (when W3LOCK=1)	108
Table 5.8	LRU and Way Replacement (when W2LOCK=1 and W3LOCK=1).....	108
Table 6.1	INTC Pins.....	119
Table 6.2	INTC Registers	120
Table 6.3	IRL3–IRL0/IRLS3–IRLS0 Pins and Interrupt Levels	123
Table 6.4	Interrupt Exception Handling Sources and Priority (IRQ Mode)	126
Table 6.5	Interrupt Exception Handling Sources and Priority (IRL Mode).....	128
Table 6.6	Interrupt Levels and INTEVT Codes.....	130
Table 6.7	Interrupt Request Sources and IPRA–IPRE.....	131
Table 6.8	Interrupt Response Time.....	146
Table 7.1	Register Configuration.....	151
Table 7.2	Data Access Cycle Addresses and Operand Size Comparison Conditions.....	171
Table 8.1	Power-Down Modes	182

Table 8.2	Pin Configuration.....	183
Table 8.3	Register Configuration.....	183
Table 8.4	Register States in Standby Mode	188
Table 9.1	CPG Pins and Functions	206
Table 9.2	CPG Register	206
Table 9.3	Clock Operating Modes.....	207
Table 9.4	Available Combinations of Clock Mode and FRQCR Values.....	208
Table 9.5	Register Configuration.....	214
Table 10.1	BSC Pins.....	226
Table 10.2	BSC Registers.....	228
Table 10.3	Physical Address Space Map.....	230
Table 10.4	Correspondence between External Pins (MD4 and MD3) and Memory Size.....	231
Table 10.5	PCMCIA Interface Characteristics	232
Table 10.6	PCMCIA Support Interface	233
Table 10.7	32-Bit External Device/Big-Endian Access and Data Alignment	260
Table 10.8	16-Bit External Device/Big-Endian Access and Data Alignment	261
Table 10.9	8-Bit External Device/Big-Endian Access and Data Alignment	262
Table 10.10	32-Bit External Device/Little-Endian Access and Data Alignment.....	263
Table 10.11	16-Bit External Device/Little-Endian Access and Data Alignment.....	263
Table 10.12	8-Bit External Device/Little-Endian Access and Data Alignment.....	264
Table 10.13	Relationship between Bus Width, AMX Bits, and Address Multiplex Output	279
Table 10.14	Example of Correspondence between SH7709S and Synchronous DRAM Address Pins (AMX [3:0] = 0100 (32-Bit Bus Width)).....	281
Table 10.15	MCSCRx Settings and $\overline{\text{MCS}}[x]$ Assertion Conditions (x: 0–7).....	324
Table 11.1	DMAC Pins	330
Table 11.2	DMAC Registers	331
Table 11.3	Selecting External Request Modes with RS Bits	347
Table 11.4	Selecting On-Chip Peripheral Module Request Modes with RS3-0 Bits.....	348
Table 11.5	Supported DMA Transfers.....	352
Table 11.6	Relationship between Request Modes and Bus Modes by DMA Transfer Category	361
Table 11.7	Register Configuration.....	377
Table 11.8	Transfer Conditions and Register Settings for Transfer between On-Chip SCI and External Memory	383
Table 11.9	Transfer Conditions and Register Settings for Transfer between On-Chip A/D Converter and External Memory	384
Table 11.10	Values in DMAC after End of Fourth Transfer	385
Table 11.11	Transfer Conditions and Register Settings for Transfer between External Memory and SCIF Transmitter.....	386
Table 12.1	TMU Pin.....	391
Table 12.2	TMU Registers.....	391
Table 12.3	TMU Interrupt Sources.....	405
Table 13.1	RTC Pins.....	409

Table 13.2	RTC Registers.....	410
Table 13.3	Day-of-Week Codes (RWKCNT)	413
Table 13.4	Day-of-Week Codes (RWKAR).....	417
Table 13.5	Recommended Oscillator Circuit Constants (Recommended Values).....	425
Table 14.1	SCI Pins	431
Table 14.2	SCI Registers	432
Table 14.3	SCSMR Settings	446
Table 14.4	Bit Rates and SCBRR Settings in Asynchronous Mode	447
Table 14.5	Bit Rates and SCBRR Settings in Synchronous Mode	450
Table 14.6	Maximum Bit Rates for Various Frequencies with Baud Rate Generator (Asynchronous Mode)	451
Table 14.7	Maximum Bit Rates with External Clock Input (Asynchronous Mode).....	452
Table 14.8	Maximum Bit Rates with External Clock Input (Synchronous Mode)	452
Table 14.9	Serial Mode Register Settings and SCI Communication Formats	454
Table 14.10	SCSMR and SCSCR Settings and SCI Clock Source Selection	454
Table 14.11	Serial Communication Formats (Asynchronous Mode)	456
Table 14.12	Receive Error Conditions and SCI Operation.....	464
Table 14.13	SCI Interrupt Sources	484
Table 14.14	SCSSR Status Flags and Transfer of Receive Data	485
Table 15.1	Smart Card Interface Pins	491
Table 15.2	Registers	491
Table 15.3	Register Settings for Smart Card Interface	497
Table 15.4	Relationship of n to CKS1 and CKS0.....	499
Table 15.5	Examples of Bit Rate B (Bits/s) for SCBRR Settings (n = 0).....	499
Table 15.6	Examples of SCBRR Settings for Bit Rate B (Bits/s) (n = 0).....	499
Table 15.7	Maximum Bit Rates for Frequencies (Smart Card Interface Mode).....	500
Table 15.8	Register Set Values and SCK Pin	500
Table 15.9	Smart Card Mode Operating State and Interrupt Sources.....	507
Table 16.1	SCIF Pins	515
Table 16.2	SCIF Registers	516
Table 16.3	SCSMR Settings	528
Table 16.4	Bit Rates and SCBRR Settings	528
Table 16.5	Maximum Bit Rates for Various Frequencies with Baud Rate Generator (Asynchronous Mode)	532
Table 16.6	Maximum Bit Rates with External Clock Input (Asynchronous Mode).....	533
Table 16.7	SCSMR Settings and SCIF Communication Formats	537
Table 16.8	SCSCR Settings and SCIF Clock Source Selection.....	538
Table 16.9	Serial Communication Formats	538
Table 16.10	SCIF Interrupt Sources	550
Table 17.1	IrDA Pins	559
Table 17.2	IrDA Registers	560
Table 18.1	List of Multiplexed Pins	565
Table 18.2	Pin Function Controller Registers.....	569

Table 19.1	Port A Register	587
Table 19.2	Port A Data Register (PADR) Read/Write Operations	588
Table 19.3	Port B Register.....	589
Table 19.4	Port B Data Register (PBDR) Read/Write Operations	590
Table 19.5	Port C Register.....	591
Table 19.6	Port C Data Register (PCDR) Read/Write Operations	592
Table 19.7	Port D Register	593
Table 19.8	Port D Data Register (PDDR) Read/Write Operations	594
Table 19.9	Port E Register.....	595
Table 19.10	Port E Data Register (PEDR) Read/Write Operations	596
Table 19.11	Port F Register	597
Table 19.12	Port F Data Register (PFDR) Read/Write Operations	598
Table 19.13	Port G Register	599
Table 19.14	Port G Data Register (PGDR) Read/Write Operations	600
Table 19.15	Port H Register	601
Table 19.16	Port H Data Register (PHDR) Read/Write Operations	602
Table 19.17	Port J Register.....	603
Table 19.18	Port J Data Register (PJDR) Read/Write Operations.....	604
Table 19.19	Port K Register	605
Table 19.20	Port K Data Register (PKDR) Read/Write Operations	606
Table 19.21	Port L Register.....	607
Table 19.22	Port L Data Register (PLDR) Read/Write Operation	608
Table 19.23	SC Port Register	609
Table 19.24	Read/Write Operation of the SC Port Data Register (SCPDR)	611
Table 20.1	A/D Converter Pins.....	615
Table 20.2	A/D Converter Registers.....	616
Table 20.3	Analog Input Channels and A/D Data Registers	617
Table 20.4	A/D Conversion Time (Single Mode).....	630
Table 20.5	Analog Input Pin Ratings.....	634
Table 20.6	Relationship between Access Size and Read Data	634
Table 21.1	D/A Converter Pins.....	636
Table 21.2	D/A Converter Registers.....	636
Table 22.1	UDI Registers	643
Table 22.2	UDI Commands.....	644
Table 22.3	Pins of this LSI and Boundary Scan Register Bits.....	645
Table 22.4	Reset Configuration	652
Table 23.1	Absolute Maximum Ratings	657
Table 23.2	DC Characteristics	659
Table 23.3	Permitted Output Current Values.....	662
Table 23.4	Operating Frequency Range	663
Table 23.5	Clock Timing	664
Table 23.6	Control Signal Timing	670
Table 23.7	Bus Timing	673

Table 23.8	Peripheral Module Signal Timing.....	706
Table 23.9	UDI-Related Pin Timing.....	709
Table 23.10	A/D Converter Characteristics.....	713
Table 23.11	D/A Converter Characteristics.....	713
Table A.1	Pin States during Resets, Power-Down States, and Bus-Released State.....	715
Table A.2	Pin Specifications	719
Table A.3	Pin States (Ordinary Memory/Little Endian).....	725
Table A.4	Pin States (Ordinary Memory/Big Endian).....	727
Table A.5	Pin States (Burst ROM/Little Endian)	729
Table A.6	Pin States (Burst ROM/Big Endian)	731
Table A.7	Pin States (Synchronous DRAM/Little Endian)	733
Table A.8	Pin States (Synchronous DRAM/Big Endian)	734
Table A.9	Pin States (PCMCIA/Little Endian).....	735
Table A.10	Pin States (PCMCIA/Big Endian)	737
Table B.1	Memory-Mapped Control Registers	739
Table B.2	Register Bits	745
Table C.1	SH7709S Models	757

Section 1 Overview and Pin Functions

1.1 SH7709S Features

This LSI is a single-chip RISC microprocessor that integrates a Renesas Technology-original RISC-type SuperH™ architecture CPU as its core that has an on-chip multiplier, cache memory, and a memory management unit (MMU) as well as peripheral functions required for system configuration such as a timer, a realtime clock, an interrupt controller, and a serial communication interface. This LSI includes data protection, virtual memory, and other functions provided by incorporating an MMU into a SuperH Series microprocessor (SH-1 or SH-2).

High-speed data transfers can be performed by an on-chip direct memory access controller (DMAC) and an external memory access support function enables direct connection to different types of memory. The SH7709S microprocessor also supports an infrared communication function, an A/D converter, and a D/A converter.

A powerful built-in power management function keeps power consumption low, even during high-speed operation. This LSI can run at six times the frequency of the system bus operating speed, making it optimum for electrical devices such as PDAs that require both high speed and low power.

The features of this LSI is listed in table 1.1. The specifications are shown in table 1.2.

Note: SuperH is a trademark of Renesas Technology, Corp.

Table 1.1 SH7709S Features

Item	Features
CPU	<ul style="list-style-type: none">• Original Renesas Technology SuperH architecture• Object code level with SH-1, SH-2, and SH-3 Series• 32-bit internal data bus• General-register files<ul style="list-style-type: none">— Sixteen 32-bit general registers (eight 32-bit shadow registers)— Eight 32-bit control registers— Four 32-bit system registers• RISC-type instruction set<ul style="list-style-type: none">— Instruction length: 16-bit fixed length for improved code efficiency— Load-store architecture— Delayed branch instructions— Instruction set based on C language• Instruction execution time: one instruction/cycle for basic instructions• Logical address space: 4 Gbytes• Space identifier ASID: 8 bits, 256 logical address space• Five-stage pipeline
Clock pulse generator (CPG)	<ul style="list-style-type: none">• Clock mode: An input clock can be selected from the external input (EXTAL or CKIO) or crystal oscillator.• Three types of clocks generated:<ul style="list-style-type: none">— CPU clock: 1–24 times the input clock, maximum 200 MHz— Bus clock: 1–4 times the input clock, maximum 66.67 MHz— Peripheral clock: 1/4–4 times the input clock, maximum 33.34 MHz• Power-down modes:<ul style="list-style-type: none">— Sleep mode— Standby mode— Module standby mode• One-channel watchdog timer
Memory management unit (MMU)	<ul style="list-style-type: none">• 4 Gbytes of address space, 256 address spaces (ASID 8 bits)• Page unit sharing• Supports multiple page sizes: 1, 4 kbytes• 128-entry, 4-way set associative TLB• Supports software selection of replacement method and random-replacement algorithms

Item	Features
Cache memory	<ul style="list-style-type: none"> • 16-kbyte cache, mixed instruction/data • 256 entries, 4-way set associative, 16-byte block length • Write-back, write-through, LRU replacement algorithm • 1-stage write-back buffer • Maximum 2 ways of the cache can be locked
Interrupt controller (INTC)	<ul style="list-style-type: none"> • 23 external interrupt pins (NMI, IRQ5–IRQ0, PINT15 to PINT0) • On-chip peripheral interrupts: set priority levels for each module
User break controller (UBC)	<ul style="list-style-type: none"> • 2 break channels • Addresses, data values, type of access, and data size can all be set as break conditions • Supports a sequential break function
Bus state controller (BSC)	<ul style="list-style-type: none"> • Physical address space divided into six areas (area 0, areas 2 to 6), each a maximum of 64 Mbytes, with the following features settable for each area: <ul style="list-style-type: none"> — Bus size (8, 16, or 32 bits) — Number of wait cycles (also supports a hardware wait function) — Setting the type of space enables direct connection to SRAM, Synchronous DRAM, and burst ROM — Supports PCMCIA interface (2 channels) — Outputs chip select signal (CS0, CS2–CS6) for corresponding area • Synchronous DRAM refresh function <ul style="list-style-type: none"> — Programmable refresh interval — Support self-refresh mode • Synchronous DRAM burst access function • Usable as either big or little endian machine
User-debugging Interface (UDI)	<ul style="list-style-type: none"> • E10A emulator support • JTAG-compliant • Realtime branch address trace • 1-kB on-chip RAM for fast emulation program execution
Timer (TMU)	<ul style="list-style-type: none"> • 3-channel auto-reload-type 32-bit timer • Input capture function • 6 types of counter input clocks can be selected • Maximum resolution: 2 MHz
Realtime clock (RTC)	<ul style="list-style-type: none"> • Built-in clock, calendar functions, and alarm functions • On-chip 32-kHz crystal oscillator circuit with a maximum resolution (interrupt cycle) of 1/256 second

Item	Features
Serial communication interface 0 (SCI0/SCI)	<ul style="list-style-type: none"> Asynchronous mode or clock synchronous mode can be selected Full-duplex communication Supports smart card interface
Serial communication interface 1 (SCI1/IrDA)	<ul style="list-style-type: none"> 16-byte FIFO for transmission/reception DMA can be transferred IrDA: interface based on 1.0
Serial communication interface 2 (SCI2/SCIF)	<ul style="list-style-type: none"> 16-byte FIFO for transmission/reception DMA can be transferred Hardware flow control
Direct memory access controller (DMAC)	<ul style="list-style-type: none"> 4 channels Burst mode and cycle-steal mode Data transfer size: 8-/16-/32-bit and 16-byte
I/O port	<ul style="list-style-type: none"> Twelve 8-bit ports
A/D converter (ADC)	<ul style="list-style-type: none"> 10 bits \pm 4 LSB, 8 channels Conversion time: 16 μs Input range: 0–AVcc (max. 3.6 V)
D/A converter (DAC)	<ul style="list-style-type: none"> 8 bits \pm 4 LSB, 2 channels Conversion time: 10 μs Output range: 0–AVcc (max. 3.6 V)

Product lineup	Power Supply Voltage		Operating Frequency	Model Name	Package
	Abbr.	I/O			
SH7709S	3.3 \pm 0.3 V	2.0 \pm 0.15 V*	200 MHz	HD6417709SHF200B	208-pin plastic HQFP (FP-208E)
		1.9 \pm 0.15 V	167 MHz	HD6417709SF167B	208-pin plastic LQFP (FP-208C)
	1.8+0.25 V 1.8–0.15 V	1.8–0.15 V	133 MHz	HD6417709SF133B	208-pin plastic LQFP (FP-208C)
				HD6417709SBP133B	240-pin CSP (BP-240A)
	1.7+0.25 V 1.7–0.15 V	1.7–0.15 V	100 MHz	HD6417709SF100B	208-pin plastic LQFP (FP-208C)
				HD6417709SBP100B	240-pin CSP (BP-240A)

Note: * 2.0 (+0.15, –0.1) V when an IRL or IRLS interrupt is used.

Table 1.2 Characteristics

Item	Characteristics
Power supply voltage	<ul style="list-style-type: none">I/O: 3.3 \pm0.3 VInternal: 2.0 \pm0.15 V (200 MHz model)*, 1.9\pm0.15 V (167 MHz model), 1.8 (+0.25, -0.15) V (133 MHz model), 1.7(+0.25, -0.15) V (100 MHz model)
Operating frequency	<ul style="list-style-type: none">Internal frequency: maximum 200 MHz(200 MHz model), 167 MHz (167 MHz model) 133.34 MHz (133 MHz model), 100 MHz (100 MHz model); external frequency: maximum 66.67 MHz
Process	<ul style="list-style-type: none">0.25-μm CMOS/5-layer metal

Note: * 2.0 (+0.15, -0.1) V when an IRL or IRLS interrupt is used.

1.2 Block Diagram

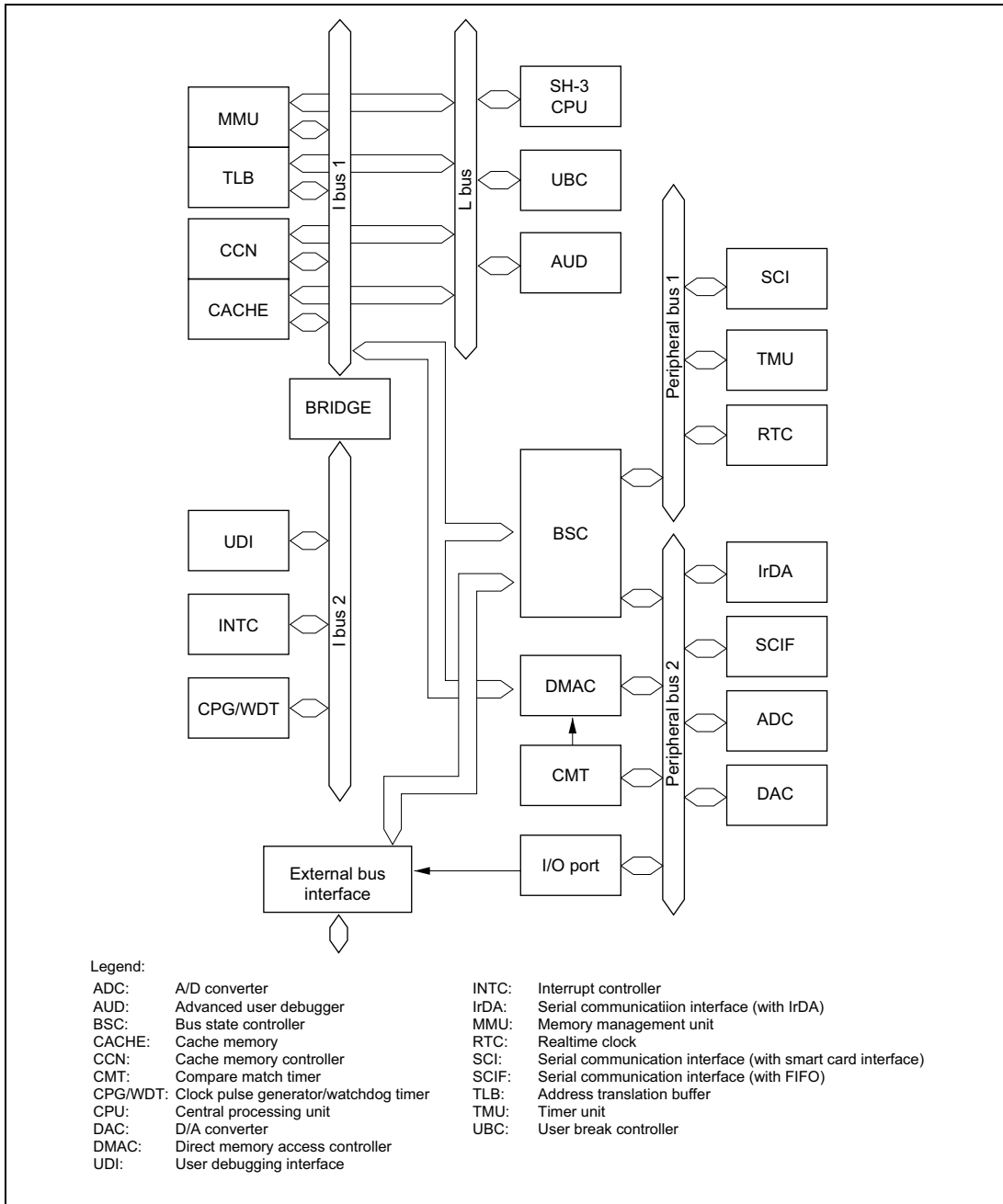

Figure 1.1 Block Diagram

1.3 Pin Description

1.3.1 Pin Assignment

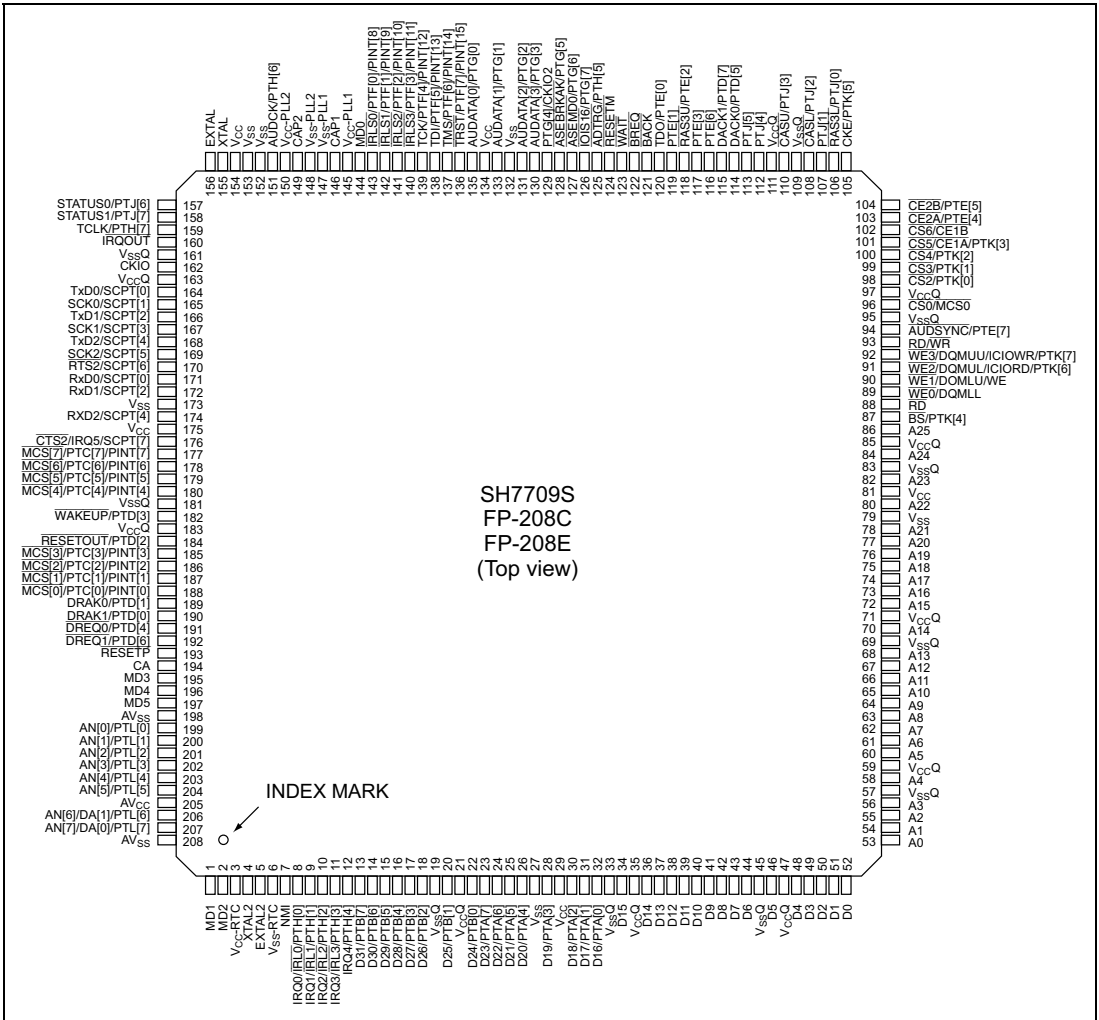
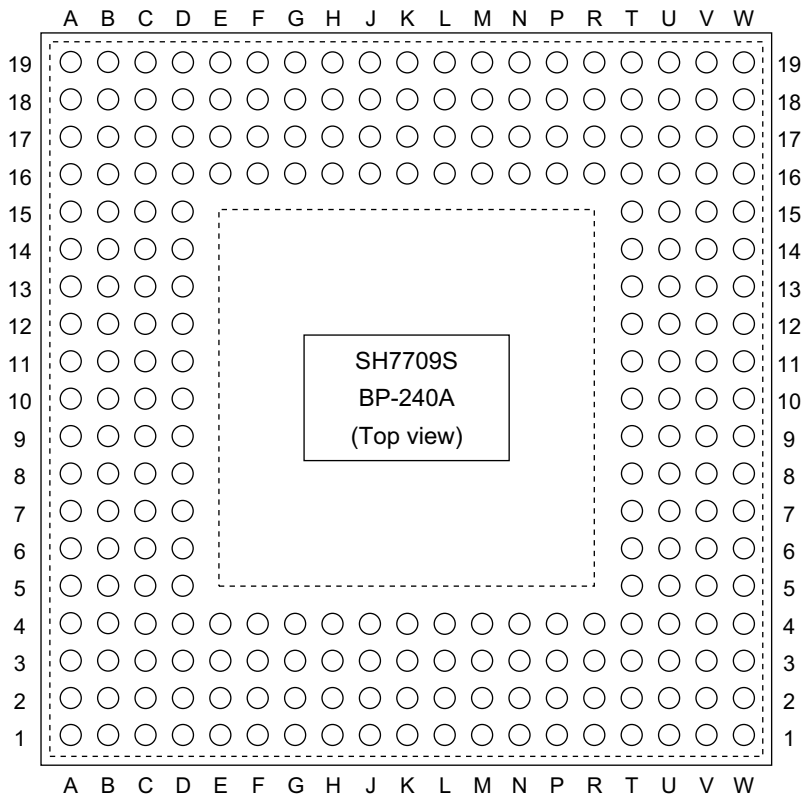

Figure 1.2 Pin Assignment (FP-208C, FP-208E)



Note: The pin area enclosed in broken lines is an inner view.

Figure 1.3 Pin Assignment (BP-240A)

1.3.2 Pin Function

Table 1.3 SH7709S Pin Function

Number of Pins				
FP-208C FP-208E	BP-240A	Pin Name	I/O	Description
1	D2	MD1	I	Clock mode setting
2	C2	MD2	I	Clock mode setting
3	E2	Vcc-RTC ^{*1}	—	RTC power supply (^{*3})
4	D1	XTAL2	O	On-chip RTC crystal oscillator pin
5	D3	EXTAL2	I	On-chip RTC crystal oscillator pin ^{*6}
6	E1	Vss-RTC ^{*1}	—	RTC power supply (0 V)
7	C3	NMI	I	Nonmaskable interrupt request
8	E3	IRQ0/ $\overline{\text{IRL0}}$ /PTH[0]	I	External interrupt request/input port H
9	E4	IRQ1/ $\overline{\text{IRL1}}$ /PTH[1]	I	External interrupt request/input port H
10	F1	IRQ2/ $\overline{\text{IRL2}}$ /PTH[2]	I	External interrupt request/input port H
11	F2	IRQ3/ $\overline{\text{IRL3}}$ /PTH[3]	I	External interrupt request/input port H
12	F3	IRQ4/PTH[4]	I	External interrupt request/input port H
13	F4	D31/PTB[7]	I/O	Data bus / input/output port B
14	G1	D30/PTB[6]	I/O	Data bus / input/output port B
15	G2	D29/PTB[5]	I/O	Data bus / input/output port B
16	G3	D28/PTB[4]	I/O	Data bus / input/output port B
17	G4	D27/PTB[3]	I/O	Data bus / input/output port B
18	H1	D26/PTB[2]	I/O	Data bus / input/output port B
19	H2	VssQ	—	Input/output power supply (0 V)
20	H3	D25/PTB[1]	I/O	Data bus / input/output port B
21	H4	VccQ	—	Input/output power supply (3.3 V)
22	J1	D24/PTB[0]	I/O	Data bus / input/output port B
23	J2	D23/PTA[7]	I/O	Data bus / input/output port A
24	J4	D22/PTA[6]	I/O	Data bus / input/output port A
25	J3	D21/PTA[5]	I/O	Data bus / input/output port A
26	K2	D20/PTA[4]	I/O	Data bus / input/output port A

Number of Pins

FP-208C FP-208E	BP-240A	Pin Name	I/O	Description
27	K3	Vss	—	Power supply (0 V)
—	K4	Vss	—	Power supply (0 V)
28	K1	D19/PTA[3]	I/O	Data bus / input/output port A
29	L3	Vcc	—	Power supply (1.9 V/1.8 V ^{*3})
—	L4	Vcc	—	Power supply (^{*3})
30	L2	D18/PTA[2]	I/O	Data bus / input/output port A
31	L1	D17/PTA[1]	I/O	Data bus / input/output port A
32	M4	D16/PTA[0]	I/O	Data bus / input/output port A
33	M3	VssQ	—	Input/output power supply (0 V)
34	M2	D15	I/O	Data bus
35	M1	VccQ	—	Input/output power supply (3.3 V)
36	N4	D14	I/O	Data bus
37	N3	D13	I/O	Data bus
38	N2	D12	I/O	Data bus
39	N1	D11	I/O	Data bus
40	P4	D10	I/O	Data bus
41	P3	D9	I/O	Data bus
42	P2	D8	I/O	Data bus
43	P1	D7	I/O	Data bus
44	R4	D6	I/O	Data bus
45	R3	VssQ	—	Input/output power supply (0 V)
46	T4	D5	I/O	Data bus
47	R1	VccQ	—	Input/output power supply (3.3 V)
48	T3	D4	I/O	Data bus
49	T1	D3	I/O	Data bus
50	R2	D2	I/O	Data bus
51	U2	D1	I/O	Data bus
52	T2	D0	I/O	Data bus
53	V4	A0	O	Address bus
54	V3	A1	O	Address bus
55	V5	A2	O	Address bus
56	W4	A3	O	Address bus

Number of Pins

FP-208C				
FP-208E	BP-240A	Pin Name	I/O	Description
57	U4	VssQ	—	Input/output power supply (0 V)
58	W5	A4	O	Address bus
59	U3	VccQ	—	Input/output power supply (3.3 V)
60	U5	A5	O	Address bus
61	T5	A6	O	Address bus
62	W6	A7	O	Address bus
63	V6	A8	O	Address bus
64	U6	A9	O	Address bus
65	T6	A10	O	Address bus
66	W7	A11	O	Address bus
67	V7	A12	O	Address bus
68	U7	A13	O	Address bus
69	T7	VssQ	—	Input/output power supply (0 V)
70	W8	A14	O	Address bus
71	V8	VccQ	—	Input/output power supply (3.3 V)
72	U8	A15	O	Address bus
73	T8	A16	O	Address bus
74	W9	A17	O	Address bus
75	V9	A18	O	Address bus
76	T9	A19	O	Address bus
77	U9	A20	O	Address bus
78	V10	A21	O	Address bus
79	U10	Vss	—	Power supply (0 V)
—	T10	Vss	O	Power supply (0 V)
80	W10	A22	O	Address bus
81	U11	Vcc	—	Power supply (*3)
—	T11	Vcc	—	Power supply (*3)
82	V11	A23	O	Address bus
83	W11	VssQ	—	Input/output power supply (0 V)
84	T12	A24	O	Address bus
85	U12	VccQ	—	Input/output power supply (3.3 V)
86	V12	A25	O	Address bus

Number of Pins

FP-208C FP-208E	BP-240A	Pin Name	I/O	Description
87	W12	$\overline{BS}/PTK[4]$	O / I/O	Bus cycle start signal / input/output port K
88	T13	\overline{RD}	O	Read strobe
89	U13	$\overline{WE0}/DQMLL$	O	D7–D0 select signal / DQM (SDRAM)
90	V13	$\overline{WE1}/DQMLU/\overline{WE}$	O	D15–D8 select signal / DQM (SDRAM)
91	W13	$\overline{WE2}/DQMUL/\overline{ICIOR}/PTK[6]$	O / I/O	D23–D16 select signal / DQM (SDRAM) / PCMCIA I/O read / input/output port K
92	T14	$\overline{WE3}/DQMUU/\overline{ICIOR}/PTK[7]$	O / I/O	D31–D24 select signal / DQM (SDRAM) / PCMCIA I/O write / input/output port K
93	U14	RD/\overline{WR}	O	Read/write
94	V14	$\overline{AUDSYN}/PTE[7]$	O / I/O	AUD synchronous / input/output port E
95	W14	VssQ	—	Input/output power supply (0 V)
96	T15	$\overline{CS0}/MCS[0]$	O	Chip select 0/mask ROM chip select 0
97	U15	VccQ	—	Input/output power supply (3.3 V)
98	T16	$\overline{CS2}/PTK[0]$	O / I/O	Chip select 2 / input/output port K
99	W15	$\overline{CS3}/PTK[1]$	O / I/O	Chip select 3 / input/output port K
100	U16	$\overline{CS4}/PTK[2]$	O / I/O	Chip select 4 / input/output port K
101	W16	$\overline{CS5}/\overline{CE1A}/PTK[3]$	O / I/O	Chip select 5/CE1 (area 5 PCMCIA) / input/output port K
102	V15	$\overline{CS6}/\overline{CE1B}$	O	Chip select 6/CE1 (area 6 PCMCIA)
103	V17	$\overline{CE2A}/PTE[4]$	O / I/O	CE2 (area 5 PCMCIA) / input/output port E
104	V16	$\overline{CE2B}/PTE[5]$	O / I/O	CE2 (area 6 PCMCIA) / input/output port E
105	T18	$CKE/PTK[5]$	O / I/O	CK enable (SDRAM) / input/output port K

Number of Pins

FP-208C

FP-208E	BP-240A	Pin Name	I/O	Description
106	U18	$\overline{\text{RAS3L}}/\text{PTJ}[0]$	O / I/O	Lower 32 M / 64 Mbytes address (SDRAM) RAS / input/output port J
107	U19	PTJ[1]	O / I/O	Input/output port J ^{*5}
108	R18	$\overline{\text{CASL}}/\text{PTJ}[2]$	O / I/O	Lower 32 M / 64 Mbytes address (SDRAM) CAS / input/output port J
109	T19	VssQ	—	Input/output power supply (0 V)
110	T17	$\overline{\text{CASU}}/\text{PTJ}[3]$	O / I/O	Lower 32 Mbytes address (SDRAM) CAS / input/output port J
111	R19	VccQ	—	Input/output power supply (3.3 V)
112	U17	PTJ[4]	I/O	Input/output port J
113	R17	PTJ[5]	I/O	Input/output port J
114	R16	DACK0/PTD[5]	O / I/O	DMA acknowledge 0 / input/output port D
115	P19	DACK1/PTD[7]	O / I/O	DMA acknowledge 1 / input/output port D
116	P18	PTE[6]	I/O	Input/output port E
117	P17	PTE[3]	I/O	Input/output port E
118	P16	$\overline{\text{RAS3U}}/\text{PTE}[2]$	O / I/O	Upper 32 Mbytes address (SDRAM) RAS / input/output port E
119	N19	PTE[1]	I/O	Input/output port E
120	N18	TDO/PTE[0]	O / I/O	Test data output / input/output port E
121	N17	$\overline{\text{BACK}}$	O	Bus acknowledge
122	N16	$\overline{\text{BREQ}}$	I	Bus request
123	M19	$\overline{\text{WAIT}}$	I	Hardware wait request
124	M18	$\overline{\text{RESETM}}$	I	Manual reset request
125	M17	$\overline{\text{ADTRG}}/\text{PTH}[5]$	I	Analog trigger / input port H
126	M16	$\overline{\text{IOIS16}}/\text{PTG}[7]$	I	IOIS16 (PCMCIA) / input port G
127	L19	$\overline{\text{ASEMD0}}/\text{PTG}[6]$	I	ASE mode ^{*4} / input port G
128	L18	$\overline{\text{ASEBRKAK}}/\text{PTG}[5]$	O/I	ASE break acknowledge / input port G
129	L16	PTG[4]/CK102	I	Input port G / clock output

Number of Pins

FP-208C FP-208E	BP-240A	Pin Name	I/O	Description
130	L17	AUDATA[3]/PTG[3]	I/O / I	AUD data / input port G
131	K18	AUDATA[2]/PTG[2]	I/O/I	AUD data / input port G
132	K17	Vss	—	Power supply (0 V)
—	K16	Vss	—	Power supply (0 V)
133	K19	AUDATA[1]/PTG[1]	I/O / I	AUD data / input port G
134	J17	Vcc	—	Power supply (*3)
—	J16	Vcc	—	Power supply (*3)
135	J18	AUDATA[0]/PTG[0]	I/O / I	AUD data / input port G
136	J19	$\overline{\text{TRST}}$ /PTF[7]/PINT[15]	I	Test reset / input port F / port interrupt
137	H16	TMS/PTF[6]/PINT[14]	I	Test mode switch / input port F / port interrupt
138	H17	TDI/PTF[5]/PINT[13]	I	Test data input / input port F / port interrupt
139	H18	TCK/PTF[4]/PINT[12]	I	Test clock / input port F / port interrupt
140	H19	$\overline{\text{IRLS3}}$ /PTF[3]/PINT[11]	I	External interrupt request / input port F / port interrupt
141	G16	$\overline{\text{IRLS2}}$ /PTF[2]/PINT[10]	I	External interrupt request / input port F / port interrupt
142	G17	$\overline{\text{IRLS1}}$ /PTF[1]/PINT[9]	I	External interrupt request / input port F / port interrupt
143	G18	$\overline{\text{IRLS0}}$ /PTF[0]/PINT[8]	I	External interrupt request / input port F / port interrupt
144	G19	MD0	I	Clock mode setting
145	F16	Vcc-PLL1*2	—	PLL1 power supply (*3)
146	F17	CAP1	—	PLL1 external capacitance pin
147	F18	Vss-PLL1*2	—	PLL1 power supply (0 V)
148	F19	Vss-PLL2*2	—	PLL2 power supply (0 V)
149	E16	CAP2	—	PLL2 external capacitance pin
150	E17	Vcc-PLL2*2	—	PLL2 power supply (*3)
151	D16	AUDCK/PTH[6]	I	AUD clock / input port H
152	E19	Vss	—	Power supply (0 V)
153	D17	Vss	—	Power supply (0 V)

Number of Pins

FP-208C				
FP-208E	BP-240A	Pin Name	I/O	Description
—	D19	Vss	—	Power supply (0 V)
154	E18	Vcc	—	Power supply (*3)
—	C19	Vcc	—	Power supply (*3)
155	C18	XTAL	O	Clock oscillator pin
156	D18	EXTAL	I	External clock / crystal oscillator pin
157	B16	STATUS0/PTJ[6]	O / I/O	Processor status / input/output port J
158	B17	STATUS1/PTJ[7]	O / I/O	Processor status / input/output port J
159	B15	TCLK/PTH[7]	I/O	TMU or RTC clock input/output / input/output port H
160	A16	$\overline{\text{IRQOUT}}$	O	Interrupt request notification
161	C16	VssQ	—	Input/output power supply (0 V)
162	A15	CKIO	I/O	System clock input/output
163	C17	VccQ	—	Power supply (3.3 V)
164	C15	TxD0/SCPT[0]	O	Transmit data 0 / SCI output port
165	D15	SCK0/SCPT[1]	I/O	Serial clock 0 / SCI input/output port
166	A14	TxD1/SCPT[2]	O	Transmit data 1 / SCI output port
167	B14	SCK1/SCPT[3]	I/O	Serial clock 1 / SCI input/output port
168	C14	TxD2/SCPT[4]	O	Transmit data 2 / SCI output port
169	D14	SCK2/SCPT[5]	I/O	Serial clock 2 / SCI input/output port
170	A13	$\overline{\text{RTS2/SCPT[6]}}$	O / I/O	Transmit request 2 / SCI input/output port
171	B13	RxD0/SCPT[0]	I	Transmit data 0 / SCI output port
172	C13	RxD1/SCPT[2]	I	Transmit data 1 / SCI output port
173	D13	Vss	—	Power supply (0 V)
—	A12	Vss	—	Power supply (0 V)
174	B12	RxD2/SCPT[4]	I	Transmit data 2 / SCI output port
175	C12	Vcc	—	Power supply (*3)
—	D12	Vcc	—	Power supply (*3)

Number of Pins

FP-208C FP-208E	BP-240A	Pin Name	I/O	Description
176	A11	$\overline{\text{CTS2}}/\text{IRQ5}/\text{SCPT}[7]$	I	Transmit clear 2 / external interrupt request / SCI input port
177	B11	$\overline{\text{MCS}}[7]/\text{PTC}[7]/\text{PINT}[7]$	O / I/O / I	Mask ROM chip select / input/output port C / port interrupt
178	D11	$\overline{\text{MCS}}[6]/\text{PTC}[6]/\text{PINT}[6]$	O / I/O / I	Mask ROM chip select / input/output port C / port interrupt
179	C11	$\overline{\text{MCS}}[5]/\text{PTC}[5]/\text{PINT}[5]$	O / I/O / I	Mask ROM chip select / input/output port C / port interrupt
180	B10	$\overline{\text{MCS}}[4]/\text{PTC}[4]/\text{PINT}[4]$	O / I/O / I	Mask ROM chip select / input/output port C / port interrupt
181	C10	VssQ	—	Input/output power supply (0 V)
182	D10	$\overline{\text{WAKEUP}}/\text{PTD}[3]$	O / I/O	Standby mode interrupt request notification / input/output port D
183	A10	VccQ	—	Input/output power supply (3.3 V)
184	C9	$\overline{\text{RESETOUT}}/\text{PTD}[2]$	O / I/O	Reset output / input/output port D
185	D9	$\overline{\text{MCS}}[3]/\text{PTC}[3]/\text{PINT}[3]$	O / I/O / I	Mask ROM chip select / input/output port C / port interrupt
186	B9	$\overline{\text{MCS}}[2]/\text{PTC}[2]/\text{PINT}[2]$	O / I/O / I	Mask ROM chip select / input/output port C / port interrupt
187	A9	$\overline{\text{MCS}}[1]/\text{PTC}[1]/\text{PINT}[1]$	O / I/O / I	Mask ROM chip select / input/output port C / port interrupt
188	D8	$\overline{\text{MCS}}[0]/\text{PTC}[0]/\text{PINT}[0]$	O / I/O / I	Mask ROM chip select / input/output port C / port interrupt
189	C8	$\overline{\text{DRAK0}}/\text{PTD}[1]$	O / I/O	DMA request acknowledge / input/output port D
190	B8	$\overline{\text{DRAK1}}/\text{PTD}[0]$	O / I/O	DMA request acknowledge / input/output port D
191	A8	$\overline{\text{DREQ0}}/\text{PTD}[4]$	I	DMA request / input port D
192	D7	$\overline{\text{DREQ1}}/\text{PTD}[6]$	I	DMA request / input port D
193	C7	$\overline{\text{RESETP}}$	I	Power-on reset request
194	B7	CA	I	Chip activate (hardware standby request signal)
195	A7	MD3	I	Area 0 bus width setting
196	D6	MD4	I	Area 0 bus width setting
197	C6	MD5	I	Endian setting

Number of Pins

FP-208C				
FP-208E	BP-240A	Pin Name	I/O	Description
198	B6	AVss	—	Analog power supply (0 V)
199	A6	AN[0]/PTL[0]	I	A/D converter input / input port L
200	D5	AN[1]/PTL[1]	I	A/D converter input / input port L
201	C5	AN[2]/PTL[2]	I	A/D converter input / input port L
202	D4	AN[3]/PTL[3]	I	A/D converter input / input port L
203	A5	AN[4]/PTL[4]	I	A/D converter input / input port L
204	C4	AN[5]/PTL[5]	I	A/D converter input / input port L
205	A4	AVcc	—	Analog power supply (3.3 V)
206	B5	AN[6]/DA[1]/PTL[6]	I	A/D converter input / D/A converter output / input port L
207	B3	AN[7]/DA[0]/PTL[7]	I	A/D converter input / D/A converter output / input port L
208	B4	AVss	—	Analog power supply (0 V)

- Notes:
1. Must be connected to the power supply even when the RTC is not used.
 2. Except in hardware standby mode, all of the power supply pins must be connected to the system power supply. (Supply power constantly.) In hardware standby mode, power must be supplied at least to $V_{CC} - RTC$ and $V_{SS} - RTC$. If power is not being supplied to any of the power supply pins other than $V_{CC} - RTC$ and $V_{SS} - RTC$, hold the CA pin low.
 3. 2.0 V for the 200 MHz model, 1.9 V for the 167 MHz model, 1.8 V for the 133 MHz model, 1.7 V for the 100 MHz model.
 4. When this LSI is used on the user system alone, without an emulator and the UDI, hold this pin at high level. When this pin is low or open, RESETP may be masked (see section 22, User Debugging Interface (UDI)).
 5. B2, B1, C1, U1, V1, W1, V2, W2, W3, W17, W18, W19, V18, V19, B19, A19, B18, A18, A17, A3, A2, and A1 are NC pins. Do not connect anything to these pins.
 6. If EXTAL2 is not used, pull this pin up to the Vcc-RTC level.

2.1 Register Configuration

2.1.1 Privileged Mode and Banks

Processor Modes: There are two processor modes: user mode and privileged mode. The SH7709S normally operates in user mode, and enters privileged mode when an exception occurs or an interrupt is accepted. There are three kinds of registers—general registers, system registers, and control registers—and the registers that can be accessed differ in the two processor modes.

General Registers: There are 16 general registers, designated R0 to R15. General registers R0 to R7 are banked registers which are switched by a processor mode change. In privileged mode, the register bank bit (RB) in the status register (SR) defines which banked register set is accessed as general registers, and which set is accessed only through the load control register (LDC) and store control register (STC) instructions.

When the RB bit is 1, the 16 registers comprising BANK1 general registers R0_BANK1–R7_BANK1 and non-banked general registers R8–R15 function as the general register set, with the 8 registers comprising BANK0 general registers R0_BANK0–R7_BANK0 accessed only by the LDC/STC instructions.

When the RB bit is 0, BANK0 general registers R0_BANK0–R7_BANK0 and nonbanked general registers R8–R15 function as the general register set, with BANK1 general registers R0_BANK1–R7_BANK1 accessed only by the LDC/STC instructions. In user mode, the 16 registers comprising bank 0 general registers R0_BANK0–R7_BANK0 and non-banked registers R8–R15 can be accessed as general registers R0–R15, and bank 1 general registers R0_BANK1–R7_BANK1 cannot be accessed.

Control Registers: Control registers comprise the global base register (GBR) and status register (SR) which can be accessed in both processor modes, and the saved status register (SSR), saved program counter (SPC), and vector base register (VBR) which can only be accessed in privileged mode. Some bits of the status register (such as the RB bit) can only be accessed in privileged mode.

System Registers: System registers comprise the multiply and accumulate registers (MACL/MACH), the procedure register (PR), and the program counter (PC). Access to these registers does not depend on the processor mode.

The register configuration in each mode is shown in figures 2.1 and 2.2.

Switching between user mode and privileged mode is controlled by the processor mode bit (MD) in the status register.



User mode register configuration

- Notes:
1. R0 functions as an index register in the indexed register-indirect addressing mode and indexed GBR-indirect addressing mode.
 2. Banked register.

Figure 2.1 User Mode Register Configuration

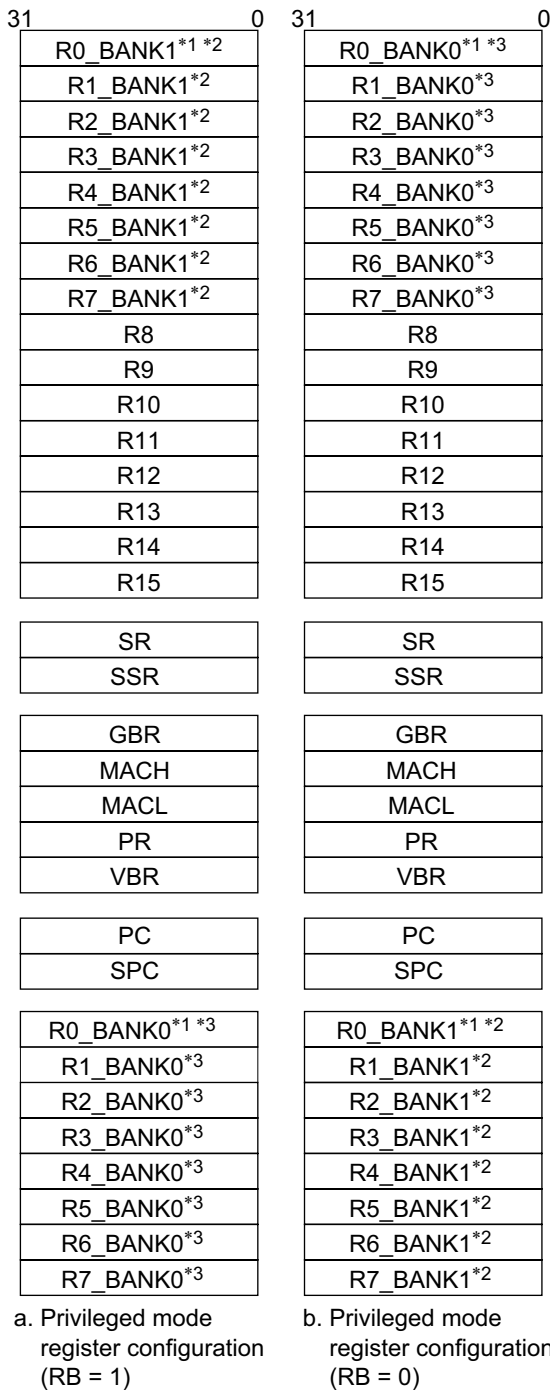

- Notes:
1. R0 functions as an index register in the indexed register-indirect addressing mode and indexed GBR-indirect addressing mode.
 2. Banked register
When the RB bit of the SR register is 1, the register can be accessed for general use. When the RB bit is 0, it can only be accessed with the LDC/STC instruction.
 3. Banked register
When the RB bit of the SR register is 0, the register can be accessed for general use. When the RB bit is 1, it can only be accessed with the LDC/STC instruction.

Figure 2.2 Privileged Mode Register Configuration

Register values after a reset are shown in table 2.1.

Table 2.1 Initial Register Values

Type	Registers	Initial Value*
General registers	R0 to R15	Undefined
Control registers	SR	MD bit = 1, RB bit = 1, BL bit = 1, I3–I0 = 1111 (H'F), reserved bits = 0, others undefined
	GBR, SSR, SPC	Undefined
	VBR	H'00000000
System registers	MACH, MACL, PR	Undefined
	PC	H'A0000000

Note: * Register values are initialized at power-on reset or manual reset.

2.1.2 General Registers

There are 16 general registers, designated R0 to R15 (figure 2.3). General registers R0 to R7 are banked registers, with a different R0–R7 register bank (R0_BANK0–R7_BANK0 or R0_BANK1–R7_BANK1) being accessed according to the processor mode. For details, see figures 2.1 and 2.2.

The general register configuration is shown in figure 2.3.

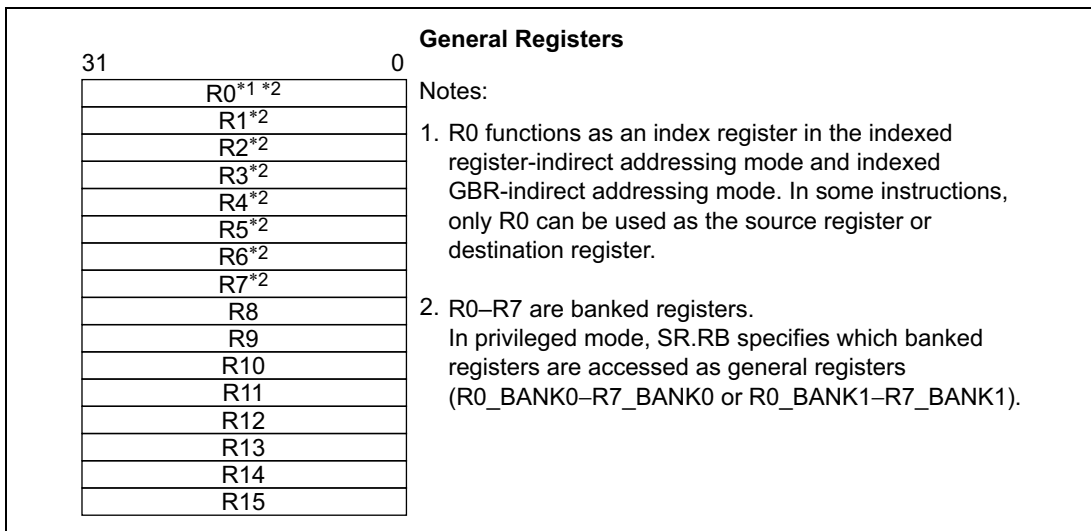

Figure 2.3 General Registers

2.1.3 System Registers

System registers can be accessed by the LDS and STS instructions. When an exception occurs, the contents of the program counter (PC) are saved in the saved program counter (SPC). The SPC contents are restored to the PC by the RTE instruction used at the end of the exception handling. There are four system registers, as follows.

- Multiply and accumulate high register (MACH)
- Multiply and accumulate low register (MACL)
- Procedure register (PR)
- Program counter (PC)

The system register configuration is shown in figure 2.4.

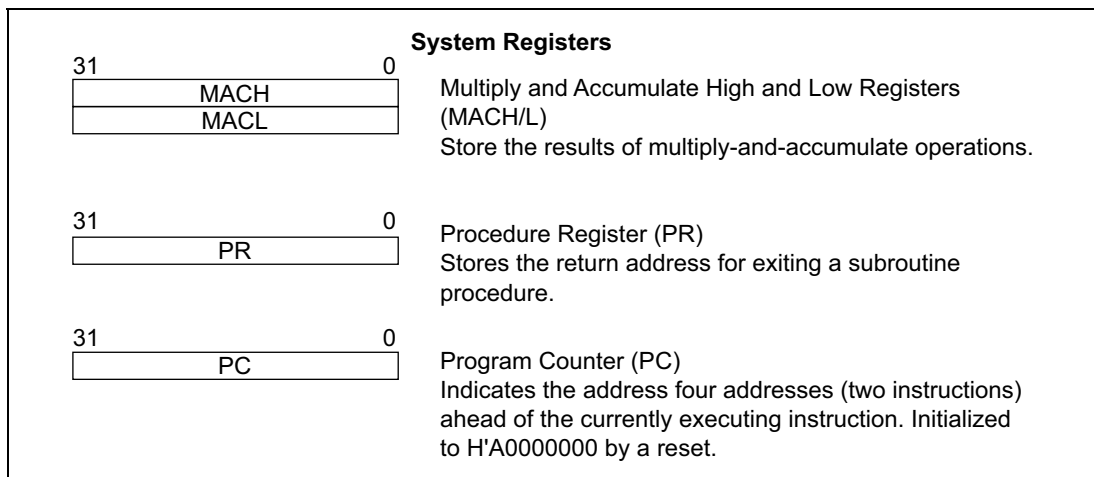

Figure 2.4 System Registers

2.1.4 Control Registers

Control registers can be accessed in privileged mode using the LDC and STC instructions. The GBR register can also be accessed in user mode. There are five control registers, as follows:

- Status register (SR)
- Saved status register (SSR)
- Saved program counter (SPC)
- Global base register (GBR)
- Vector base register (VBR)

2.2 Data Formats

2.2.1 Data Format in Registers

Register operands are always longwords (32 bits, figure 2.6). When a memory operand is only a byte (8 bits) or a word (16 bits), it is sign-extended into a longword when loaded into a register.

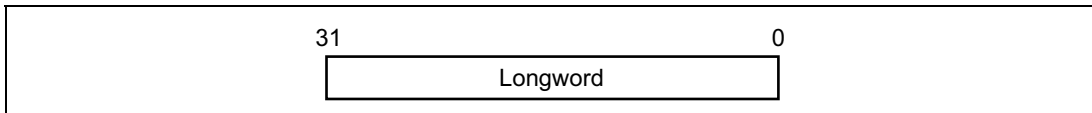

Figure 2.6 Longword

2.2.2 Data Format in Memory

Memory data formats are classified into bytes, words, and longwords. Memory can be accessed in 8-bit byte, 16-bit word, or 32-bit longword form. A memory operand less than 32 bits in length is sign-extended before being stored in a register.

A word operand must be accessed starting from a word boundary (even address of a 2-byte unit: address $2n$), and a longword operand starting from a longword boundary (even address of a 4-byte unit: address $4n$). An address error will result if this rule is not observed. A byte operand can be accessed from any address.

Big-endian or little-endian byte order can be selected for the data format. The endian mode should be set with the MD5 external pin in a power-on reset. Big-endian mode is selected when the MD5 pin is low, and little-endian when high. The endian mode cannot be changed dynamically. Bit positions are numbered left to right from most-significant to least-significant. Thus, in a 32-bit longword, the leftmost bit, bit 31, is the most significant bit and the rightmost bit, bit 0, is the least significant bit.

The data format in memory is shown in figure 2.7.

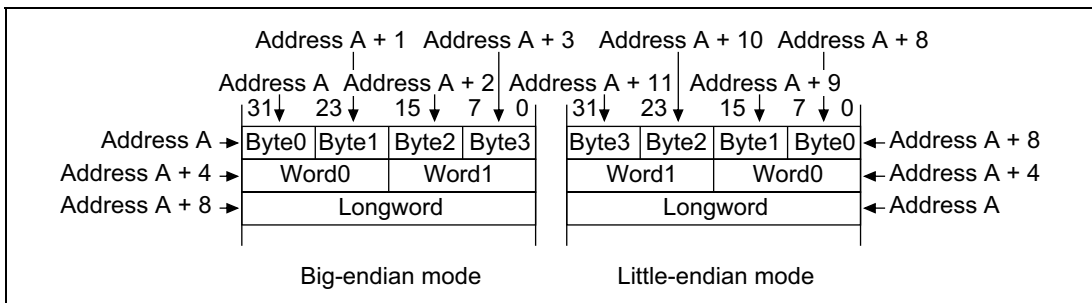

Figure 2.7 Data Format in Memory

2.3 Instruction Features

2.3.1 Execution Environment

Data Length: The SH7709S instruction set is implemented with fixed-length 16-bit wide instructions executed in a pipelined sequence with single-cycle execution for most instructions. All operations are executed in 32-bit longword units. Memory can be accessed in 8-bit byte, 16-bit word, or 32-bit longword units, with byte or word units sign-extended into 32-bit longwords. Literals are sign-extended in arithmetic operations (MOV, ADD, and CMP/EQ instructions) and zero-extended in logical operations (TST, AND, OR, and XOR instructions).

Load/Store Architecture: The SH7709S features a load-store architecture in which basic operations are executed in registers. Operations requiring memory access are executed in registers following register loading, except for bit-manipulation operations such as logical AND functions, which are executed directly in memory.

Delayed Branching: Unconditional branching is implemented as delayed branch operations. Pipeline disruptions due to branching are minimized by the execution of the instruction following the delayed branch instruction prior to branching. Conditional branch instructions are of two kinds, delayed and normal.

```
BRA      TRGET
ADD      R1, R0    ;ADD is executed prior to branching to TRGET
```

T bit: The T bit in the status register (SR) is used to indicate the result of compare operations, and is read as a TRUE/FALSE condition determining if a conditional branch is taken or not. To improve processing speed, the T bit logic state is modified only by specific operations. An example of how the T bit may be used in a sequence of operations is shown below.

```
ADD      #1, R0      ;T bit not modified by ADD operation
CMP/EQ   R1, R0      ;T bit set to 1 when R0 = 0
BT       TRGET       ;branch taken to TRGET when T bit = 1 (R0 = 0)
```

Literals: Byte-length literals are inserted directly into the instruction code as immediate data. To maintain the 16-bit fixed-length instruction code, word or longword literals are stored in a table in main memory rather than inserted directly into the instruction code. The memory table is accessed by the MOV instruction using PC-relative addressing with displacement, as follows:

```
MOV.W    @(disp, PC), R0
```

Absolute Addresses: As with word and longword literals, absolute addresses must also be stored in a table in main memory. The value of the absolute address is transferred to a register and the operand access is specified by indexed register-indirect addressing, with the absolute address loaded (like word and longword immediate data) during instruction execution.

16-Bit and 32-Bit Displacements: In the same way, 16-bit and 32-bit displacements also must be stored in a table in main memory. Exactly like absolute addresses, the displacement value is transferred to a register and the operand access is specified by indexed register-indirect addressing, loading the displacement (like word and longword immediate data) during instruction execution.

2.3.2 Addressing Modes

Addressing modes and effective address calculation methods are shown in table 2.2.

Table 2.2 Addressing Modes and Effective Addresses

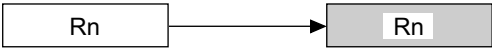
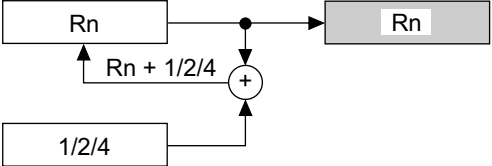
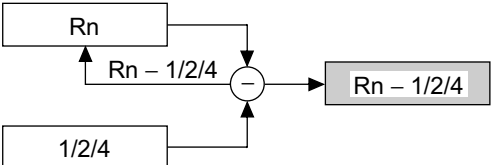
Addressing Mode	Instruction Format	Effective Address Calculation Method	Calculation Formula
Register direct	Rn	Effective address is register Rn. (Operand is register Rn contents.)	—
Register indirect	@Rn	Effective address is register Rn contents. 	Rn
Register indirect with post-increment	@Rn+	Effective address is register Rn contents. A constant is added to Rn after instruction execution: 1 for a byte operand, 2 for a word operand, 4 for a longword operand. 	Rn After instruction execution Byte: $Rn + 1 \rightarrow Rn$ Word: $Rn + 2 \rightarrow Rn$ Longword: $Rn + 4 \rightarrow Rn$
Register indirect with pre-decrement	@-Rn	Effective address is register Rn contents, decremented by a constant beforehand: 1 for a byte operand, 2 for a word operand, 4 for a longword operand. 	Byte: $Rn - 1 \rightarrow Rn$ Word: $Rn - 2 \rightarrow Rn$ Longword: $Rn - 4 \rightarrow Rn$ (Instruction executed with Rn after calculation)

Addressing Mode	Instruction Format	Effective Address Calculation Method	Calculation Formula
Register indirect with displacement	@(disp:4, Rn)	Effective address is register Rn contents with 4-bit displacement disp added. After disp is zero-extended, it is multiplied by 1 (byte), 2 (word), or 4 (longword), according to the operand size.	Byte: $Rn + disp$ Word: $Rn + disp \times 2$ Longword: $Rn + disp \times 4$
Indexed register indirect	@(R0, Rn)	Effective address is sum of register Rn and R0 contents.	$Rn + R0$
GBR indirect with displacement	@(disp:8, GBR)	Effective address is register GBR contents with 8-bit displacement disp added. After disp is zero-extended, it is multiplied by 1 (byte), 2 (word), or 4 (longword), according to the operand size.	Byte: $GBR + disp$ Word: $GBR + disp \times 2$ Longword: $GBR + disp \times 4$
Indexed GBR indirect	@(R0, GBR)	Effective address is sum of register GBR and R0 contents.	$GBR + R0$

Addressing Mode	Instruction Format	Effective Address Calculation Method	Calculation Formula
PC-relative with displacement	@(disp:8, PC)	Effective address is register PC contents with 8-bit displacement disp added. After disp is zero-extended, it is multiplied by 2 (word), or 4 (longword), according to the operand size. With a longword operand, the lower 2 bits of PC are masked.	Word: $PC + disp \times 2$ Longword: $PC \& H'FFFF FFFC + disp \times 4$
		<pre> graph TD PC[PC] --> AND((&)) H[H'FFFFFFFC] --> AND AND -- "(for longword)" --> ADD((+)) disp[disp (zero-extended)] --> MUL((x)) 2_4[2/4] --> MUL MUL --> ADD ADD --> Result["PC + disp * 2 or PC & H'FFFFFFFC + disp * 4"] </pre>	
PC-relative	disp:8	Effective address is register PC contents with 8-bit displacement disp added after being sign-extended and multiplied by 2.	$PC + disp \times 2$
		<pre> graph TD PC[PC] --> ADD((+)) disp[disp (sign-extended)] --> ADD disp --> MUL((x)) 2[2] --> MUL MUL --> ADD ADD --> Result["PC + disp * 2"] </pre>	
	disp:12	Effective address is register PC contents with 12-bit displacement disp added after being sign-extended and multiplied by 2.	$PC + disp \times 2$
		<pre> graph TD PC[PC] --> ADD((+)) disp[disp (sign-extended)] --> ADD disp --> MUL((x)) 2[2] --> MUL MUL --> ADD ADD --> Result["PC + disp * 2"] </pre>	

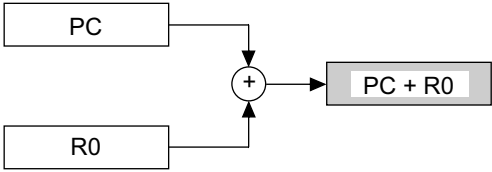
Addressing Mode	Instruction Format	Effective Address Calculation Method	Calculation Formula
PC-relative	Rn	Effective address is sum of register PC and Rn contents. 	$PC + Rn$
Immediate	#imm:8	8-bit immediate data imm of TST, AND, OR, or XOR instruction is zero-extended.	—
	#imm:8	8-bit immediate data imm of MOV, ADD, or CMP/EQ instruction is sign-extended.	—
	#imm:8	8-bit immediate data imm of TRAPA instruction is zero-extended and multiplied by 4.	—

Note: For the addressing modes below that use a displacement (disp), the assembler descriptions in this manual show the value before scaling ($\times 1$, $\times 2$, or $\times 4$) is performed according to the operand size. This is done to clarify the operation of the IC. Refer to the relevant assembler notation rules for the actual assembler descriptions.

@ (disp:4, Rn) ; Register indirect with displacement

@ (disp:8, Rn) ; GBR indirect with displacement

@ (disp:8, PC) ; PC-relative with displacement

disp:8, disp:12; PC-relative

2.3.3 Instruction Formats

Table 2.3 explains the meaning of instruction formats and source and destination operands. The meaning of the operands depends on the operation code. The following symbols are used.

xxxx: Operation code
 mmmm: Source register
 nnnn: Destination register
 iiiii: Immediate data
 dddd: Displacement

Table 2.3 Instruction Formats

Instruction Format	Source Operand	Destination Operand	Instruction Example	
0 format	<div style="display: flex; align-items: center;"> 15 <div style="border: 1px solid black; padding: 2px; display: flex; justify-content: space-between; width: 100%;"> xxxx xxxx xxxx xxxx </div> 0 </div>	—	—	NOP
n format	<div style="display: flex; align-items: center;"> 15 <div style="border: 1px solid black; padding: 2px; display: flex; justify-content: space-between; width: 100%;"> <div style="border-right: 1px solid black; padding: 2px 5px;">xxxx</div> <div style="border-right: 1px solid black; padding: 2px 5px;">nnnn</div> <div style="border-right: 1px solid black; padding: 2px 5px;">xxxx</div> <div style="padding: 2px 5px;">xxxx</div> </div> 0 </div>	—	nnnn: register direct	MOVT Rn
	Control register or system register	nnnn: register direct	STS MACH,Rn	
	Control register or system register	nnnn: register indirect with pre-decrement	STC.L SR,@-Rn	
m format	<div style="display: flex; align-items: center;"> 15 <div style="border: 1px solid black; padding: 2px; display: flex; justify-content: space-between; width: 100%;"> <div style="border-right: 1px solid black; padding: 2px 5px;">xxxx</div> <div style="border-right: 1px solid black; padding: 2px 5px;">mmmm</div> <div style="border-right: 1px solid black; padding: 2px 5px;">xxxx</div> <div style="padding: 2px 5px;">xxxx</div> </div> 0 </div>	mmmm: register direct	Control register or system register	LDC Rm,SR
	mmmm: register indirect with post-increment	Control register or system register	LDC.L @Rm+,SR	
	mmmm: register indirect	—	JMP @Rm	
	mmmm: PC-relative using Rm	—	BRAF Rm	

Instruction Format	Source Operand	Destination Operand	Instruction Example				
nm format 15 <table border="1" style="display: inline-table; vertical-align: middle;"><tr><td style="width: 25px; text-align: center;">xxxx</td><td style="width: 25px; text-align: center;">nnnn</td><td style="width: 25px; text-align: center;">mmmm</td><td style="width: 25px; text-align: center;">xxxx</td></tr></table> 0	xxxx	nnnn	mmmm	xxxx	<p>mmmm: register direct</p> <hr/> <p>mmmm: register indirect</p> <hr/> <p>mmmm: register indirect with post-increment (multiply-and-accumulate operation)</p> <p>nnnn: * register indirect with post-increment (multiply-and-accumulate operation)</p> <hr/> <p>mmmm: register indirect with post-increment</p> <hr/> <p>mmmm: register direct</p> <hr/> <p>mmmm: register direct</p>	<p>nnnn: register direct</p> <hr/> <p>nnnn: register indirect</p> <hr/> <p>MACH,MACL</p> <hr/> <p>nnnn: register direct</p> <hr/> <p>nnnn: indexed register indirect</p>	<p>ADD Rm,Rn</p> <hr/> <p>MOV.L Rm,@Rn</p> <hr/> <p>MAC.W @Rm+,@Rn+</p> <hr/> <p>MOV.L @Rm+,Rn</p> <hr/> <p>MOV.L Rm,@-Rn</p> <hr/> <p>MOV.L Rm,@(R0,Rn)</p>
xxxx	nnnn	mmmm	xxxx				
md format 15 <table border="1" style="display: inline-table; vertical-align: middle;"><tr><td style="width: 25px; text-align: center;">xxxx</td><td style="width: 25px; text-align: center;">xxxx</td><td style="width: 25px; text-align: center;">mmmm</td><td style="width: 25px; text-align: center;">dddd</td></tr></table> 0	xxxx	xxxx	mmmm	dddd	<p>mmmmdddd: register indirect with displacement</p>	<p>R0 (register direct)</p>	<p>MOV.B @(disp,Rm),R0</p>
xxxx	xxxx	mmmm	dddd				
nd4 format 15 <table border="1" style="display: inline-table; vertical-align: middle;"><tr><td style="width: 25px; text-align: center;">xxxx</td><td style="width: 25px; text-align: center;">xxxx</td><td style="width: 25px; text-align: center;">nnnn</td><td style="width: 25px; text-align: center;">dddd</td></tr></table> 0	xxxx	xxxx	nnnn	dddd	<p>R0 (register direct)</p>	<p>nnnndddd: register indirect with displacement</p>	<p>MOV.B R0,@(disp,Rn)</p>
xxxx	xxxx	nnnn	dddd				

Instruction Format		Source Operand	Destination Operand	Instruction Example
nmd format	<div style="display: flex; justify-content: space-between; align-items: center;"> 15 xxxx nnnn mmmm dddd 0 </div>	m m m m: register direct	n n n d d d d: register indirect with displacement	MOV.L Rm, @(disp, Rn)
		m m m m d d d d: register indirect with displacement	n n n n: register direct	MOV.L @(disp, Rm), Rn
d format	<div style="display: flex; justify-content: space-between; align-items: center;"> 15 xxxx xxxx dddd dddd 0 </div>	d d d d d d d d: GBR indirect with displacement	R0 (register direct)	MOV.L @(disp, GBR), R0
		R0 (register direct)	d d d d d d d d: GBR indirect with displacement	MOV.L R0, @(disp, GBR)
		d d d d d d d d: PC-relative with displacement	R0 (register direct)	MOVA @(disp, PC), R0
		d d d d d d d d: PC-relative	—	BF label
d12 format	<div style="display: flex; justify-content: space-between; align-items: center;"> 15 xxxx dddd dddd dddd 0 </div>	d d d d d d d d d d d d: PC-relative	—	BRA label (label = disp + PC)
nd8 format	<div style="display: flex; justify-content: space-between; align-items: center;"> 15 xxxx nnnn dddd dddd 0 </div>	d d d d d d d d: PC-relative with displacement	n n n n: register direct	MOV.L @(disp, PC), Rn
i format	<div style="display: flex; justify-content: space-between; align-items: center;"> 15 xxxx xxxx iiii iiii 0 </div>	i i i i i i i i: immediate	Indexed GBR indirect	AND.B #imm, @(R0, GBR)
		i i i i i i i i: immediate	R0 (register direct)	AND #imm, R0
		i i i i i i i i: immediate	—	TRAPA #imm
ni format	<div style="display: flex; justify-content: space-between; align-items: center;"> 15 xxxx nnnn iiii iiii 0 </div>	i i i i i i i i: immediate	n n n n: register direct	ADD #imm, Rn

Note: * In a multiply-and-accumulate instruction, nnnn is the source register.

2.4 Instruction Set

2.4.1 Instruction Set Classified by Function

The SH7709S instruction set includes 68 basic instruction types, as listed in table 2.4.

Table 2.4 Classification of Instructions

Classification	Types	Operation Code	Function	No. of Instructions
Data transfer	5	MOV	Data transfer	39
		MOVA	Effective address transfer	
		MOVT	T bit transfer	
		SWAP	Swap of upper and lower bytes	
		XTRCT	Extraction of middle of linked registers	
Arithmetic operations	21	ADD	Binary addition	33
		ADDC	Binary addition with carry	
		ADDV	Binary addition with overflow check	
		CMP/cond	Comparison	
		DIV1	Division	
		DIV0S	Initialization of signed division	
		DIV0U	Initialization of unsigned division	
		DMULS	Signed double-precision multiplication	
		DMULU	Unsigned double-precision multiplication	
		DT	Decrement and test	
		EXTS	Sign extension	
		EXTU	Zero extension	
		MAC	Multiply-and-accumulate operation, double-precision multiply-and-accumulate operation	

Classification	Types	Operation Code	Function	No. of Instructions
Arithmetic operations (cont)	21	MUL	Double-precision multiplication (32 × 32 bits)	33
		MULS	Signed multiplication (16 × 16 bits)	
		MULU	Unsigned multiplication (16 × 16 bits)	
		NEG	Negation	
		NEGC	Negation with borrow	
		SUB	Binary subtraction	
		SUBC	Binary subtraction with borrow	
		SUBV	Binary subtraction with underflow check	
Logic operations	6	AND	Logical AND	14
		NOT	Bit inversion	
		OR	Logical OR	
		TAS	Memory test and bit set	
		TST	Logical AND and T bit set	
		XOR	Exclusive OR	
Shift	12	ROTL	One-bit left rotation	16
		ROTR	One-bit right rotation	
		ROTCL	One-bit left rotation with T bit	
		ROTCR	One-bit right rotation with T bit	
		SHAL	One-bit arithmetic left shift	
		SHAR	One-bit arithmetic right shift	
		SHLL	One-bit logical left shift	
		SHLLn	n-bit logical left shift	
		SHLR	One-bit logical right shift	
		SHLRn	n-bit logical right shift	
		SHAD	Dynamic arithmetic shift	
		SHLD	Dynamic logical shift	

Classification	Types	Operation Code	Function	No. of Instructions
Branch	9	BF	Conditional branch, delayed conditional branch (T = 0)	11
		BT	Conditional branch, delayed conditional branch (T = 1)	
		BRA	Unconditional branch	
		BRAF	Unconditional branch	
		BSR	Branch to subroutine procedure	
		BSRF	Branch to subroutine procedure	
		JMP	Unconditional branch	
		JSR	Branch to subroutine procedure	
		RTS	Return from subroutine procedure	
System control	15	CLRMAC	MAC register clear	75
		CLRT	Clear T bit	
		CLRS	Clear S bit	
		LDC	Load to control register	
		LDS	Load to system register	
		LDTLB	Load PTE to TLB	
		NOP	No operation	
		PREF	Prefetch data to cache	
		RTE	Return from exception handling	
		SETS	Set S bit	
		SETT	Set T bit	
		SLEEP	Shift to power-down mode	
		STC	Store from control register	
		STS	Store from system register	
TRAPA	Trap exception handling			
Total: 68			188	

Table 2.5 lists the SH7709S instruction code formats.

Table 2.5 Instruction Code Format

Item	Format	Explanation
Instruction mnemonic	OP.Sz SRC,DEST	OP: Operation code Sz: Size SRC: Source DEST: Destination Rm: Source register Rn: Destination register imm: Immediate data disp: Displacement
Instruction code	MSB ↔ LSB	m m m m: Source register n n n n: Destination register 0000: R0 0001: R1 1111: R15 iiii: Immediate data dddd: Displacement*
Operation summary	→, ← (xx) M/Q/T & ^ ~ <<n, >>n	Direction of transfer Memory operand Flag bits in SR Logical AND of each bit Logical OR of each bit Exclusive OR of each bit Logical NOT of each bit n-bit shift
Privileged mode		Indicates whether privileged mode applies
Execution cycles		Value when no wait states are inserted The execution cycles listed in the table are minimums. The actual number of cycles may be increased in cases such as the following: 1. When contention occurs between instruction fetches and data access 2. When the destination register of the load instruction (memory → register) and the register used by the next instruction are the same
T bit		Value of T bit after instruction is executed —: No change

Note: * Scaling (×1, ×2, ×4) is performed according to the instruction operand size.

Table 2.6 Data Transfer Instructions

Instruction		Operation	Code	Privileged Mode	Cycles	T Bit
MOV	#imm, Rn	imm → Sign extension → Rn	1110nnnniiiiiiii	—	1	—
MOV.W	@(disp, PC), Rn	(disp × 2 + PC) → Sign extension → Rn	1001nnnnddddddd	—	1	—
MOV.L	@(disp, PC), Rn	(disp × 4 + PC) → Rn	1101nnnnddddddd	—	1	—
MOV	Rm, Rn	Rm → Rn	0110nnnnmmmm0011	—	1	—
MOV.B	Rm, @Rn	Rm → (Rn)	0010nnnnmmmm0000	—	1	—
MOV.W	Rm, @Rn	Rm → (Rn)	0010nnnnmmmm0001	—	1	—
MOV.L	Rm, @Rn	Rm → (Rn)	0010nnnnmmmm0010	—	1	—
MOV.B	@Rm, Rn	(Rm) → Sign extension → Rn	0110nnnnmmmm0000	—	1	—
MOV.W	@Rm, Rn	(Rm) → Sign extension → Rn	0110nnnnmmmm0001	—	1	—
MOV.L	@Rm, Rn	(Rm) → Rn	0110nnnnmmmm0010	—	1	—
MOV.B	Rm, @-Rn	Rn-1 → Rn, Rm → (Rn)	0010nnnnmmmm0100	—	1	—
MOV.W	Rm, @-Rn	Rn-2 → Rn, Rm → (Rn)	0010nnnnmmmm0101	—	1	—
MOV.L	Rm, @-Rn	Rn-4 → Rn, Rm → (Rn)	0010nnnnmmmm0110	—	1	—
MOV.B	@Rm+, Rn	(Rm) → Sign extension → Rn, Rm + 1 → Rm	0110nnnnmmmm0100	—	1	—
MOV.W	@Rm+, Rn	(Rm) → Sign extension → Rn, Rm + 2 → Rm	0110nnnnmmmm0101	—	1	—
MOV.L	@Rm+, Rn	(Rm) → Rn, Rm + 4 → Rm	0110nnnnmmmm0110	—	1	—
MOV.B	R0, @(disp, Rn)	R0 → (disp + Rn)	10000000nnnndddd	—	1	—
MOV.W	R0, @(disp, Rn)	R0 → (disp × 2 + Rn)	10000001nnnndddd	—	1	—
MOV.L	Rm, @(disp, Rn)	Rm → (disp × 4 + Rn)	0001nnnnmmmmdddd	—	1	—
MOV.B	@(disp, Rm), R0	(disp + Rm) → Sign extension → R0	10000100mmmmdddd	—	1	—
MOV.W	@(disp, Rm), R0	(disp × 2 + Rm) → Sign extension → R0	10000101mmmmdddd	—	1	—
MOV.L	@(disp, Rm), Rn	(disp × 4 + Rm) → Rn	0101nnnnmmmmdddd	—	1	—
MOV.B	Rm, @(R0, Rn)	Rm → (R0 + Rn)	0000nnnnmmmm0100	—	1	—

Instruction	Operation	Code	Privileged Mode	Cycles	T Bit
MOV.W Rm,@(R0,Rn)	Rm → (R0 + Rn)	0000nnnnmmmm0101	—	1	—
MOV.L Rm,@(R0,Rn)	Rm → (R0 + Rn)	0000nnnnmmmm0110	—	1	—
MOV.B @(R0,Rm),Rn	(R0 + Rm) → Sign extension → Rn	0000nnnnmmmm1100	—	1	—
MOV.W @(R0,Rm),Rn	(R0 + Rm) → Sign extension → Rn	0000nnnnmmmm1101	—	1	—
MOV.L @(R0,Rm),Rn	(R0 + Rm) → Rn	0000nnnnmmmm1110	—	1	—
MOV.B R0,@(disp,GBR)	R0 → (disp + GBR)	11000000ddddddd	—	1	—
MOV.W R0,@(disp,GBR)	R0 → (disp × 2 + GBR)	11000001ddddddd	—	1	—
MOV.L R0,@(disp,GBR)	R0 → (disp × 4 + GBR)	11000010ddddddd	—	1	—
MOV.B @(disp,GBR),R0	(disp + GBR) → Sign extension → R0	11000100ddddddd	—	1	—
MOV.W @(disp,GBR),R0	(disp × 2 + GBR) → Sign extension → R0	11000101ddddddd	—	1	—
MOV.L @(disp,GBR),R0	(disp × 4 + GBR) → R0	11000110ddddddd	—	1	—
MOVA @(disp,PC),R0	disp × 4 + PC → R0	11000111ddddddd	—	1	—
MOVT Rn	T → Rn	0000nnnn00101001	—	1	—
SWAP.B Rm,Rn	Rm → Swap the bottom two bytes → Rn	0110nnnnmmmm1000	—	1	—
SWAP.W Rm,Rn	Rm → Swap two consecutive words → Rn	0110nnnnmmmm1001	—	1	—
XTRCT Rm,Rn	Rm: Middle 32 bits of Rn → Rn	0010nnnnmmmm1101	—	1	—

Table 2.7 lists the SH7709S arithmetic instructions.

Table 2.7 Arithmetic Instructions

Instruction		Operation	Code	Privileged Mode	Cycles	T Bit
ADD	Rm, Rn	$Rn + Rm \rightarrow Rn$	0011nnnnmmmm1100	—	1	—
ADD	#imm, Rn	$Rn + imm \rightarrow Rn$	0111nnnniiiiiii	—	1	—
ADDC	Rm, Rn	$Rn + Rm + T \rightarrow Rn$, Carry $\rightarrow T$	0011nnnnmmmm1110	—	1	Carry
ADDV	Rm, Rn	$Rn + Rm \rightarrow Rn$, Overflow $\rightarrow T$	0011nnnnmmmm1111	—	1	Overflow
CMP/EQ	#imm, R0	If $R0 = imm$, $1 \rightarrow T$	10001000iiiiiii	—	1	Comparison result
CMP/EQ	Rm, Rn	If $Rn = Rm$, $1 \rightarrow T$	0011nnnnmmmm0000	—	1	Comparison result
CMP/HS	Rm, Rn	If $Rn \geq Rm$ with unsigned data, $1 \rightarrow T$	0011nnnnmmmm0010	—	1	Comparison result
CMP/GE	Rm, Rn	If $Rn \geq Rm$ with signed data, $1 \rightarrow T$	0011nnnnmmmm0011	—	1	Comparison result
CMP/HI	Rm, Rn	If $Rn > Rm$ with unsigned data, $1 \rightarrow T$	0011nnnnmmmm0110	—	1	Comparison result
CMP/GT	Rm, Rn	If $Rn > Rm$ with signed data, $1 \rightarrow T$	0011nnnnmmmm0111	—	1	Comparison result
CMP/PZ	Rn	If $Rn \geq 0$, $1 \rightarrow T$	0100nnnn00010001	—	1	Comparison result
CMP/PL	Rn	If $Rn > 0$, $1 \rightarrow T$	0100nnnn00010101	—	1	Comparison result
CMP/STR	Rm, Rn	If Rn and Rm have an equivalent byte, $1 \rightarrow T$	0010nnnnmmmm1100	—	1	Comparison result
DIV1	Rm, Rn	Single-step division (Rn/Rm)	0011nnnnmmmm0100	—	1	Calculation result
DIV0S	Rm, Rn	MSB of Rn $\rightarrow Q$, MSB of Rm $\rightarrow M$, $M \wedge Q \rightarrow T$	0010nnnnmmmm0111	—	1	Calculation result
DIV0U		$0 \rightarrow M/Q/T$	000000000011001	—	1	0

Instruction	Operation	Code	Privileged Mode	Cycles	T Bit
DMULS.L Rm, Rn	Signed operation of $Rn \times Rm \rightarrow MACH$, MACL $32 \times 32 \rightarrow 64$ bits	0011nnnnmmmm1101	—	2(to 5)*	—
DMULU.L Rm, Rn	Unsigned operation of $Rn \times Rm \rightarrow MACH$, MACL $32 \times 32 \rightarrow 64$ bits	0011nnnnmmmm0101	—	2(to 5)*	—
DT Rn	$Rn - 1 \rightarrow Rn$, if $Rn = 0$, $1 \rightarrow T$, else $0 \rightarrow T$	0100nnnn00010000	—	1	Comparison result
EXTS.B Rm, Rn	A byte in Rm is sign-extended $\rightarrow Rn$	0110nnnnmmmm1110	—	1	—
EXTS.W Rm, Rn	A word in Rm is sign-extended $\rightarrow Rn$	0110nnnnmmmm1111	—	1	—
EXTU.B Rm, Rn	A byte in Rm is zero-extended $\rightarrow Rn$	0110nnnnmmmm1100	—	1	—
EXTU.W Rm, Rn	A word in Rm is zero-extended $\rightarrow Rn$	0110nnnnmmmm1101	—	1	—
MAC.L @Rm+, @Rn+	Signed operation of (Rn) \times (Rm) + MAC \rightarrow MAC, $Rn + 4 \rightarrow Rn$, $Rm + 4 \rightarrow Rm$, $32 \times 32 + 64 \rightarrow 64$ bits	0000nnnnmmmm1111	—	2(to 5)*	—
MAC.W @Rm+, @Rn+	Signed operation of (Rn) \times (Rm) + MAC \rightarrow MAC, $Rn + 2 \rightarrow Rn$, $Rm + 2 \rightarrow Rm$, $16 \times 16 + 64 \rightarrow 64$ bits	0100nnnnmmmm1111	—	2(to 5)*	—
MUL.L Rm, Rn	$Rn \times Rm \rightarrow MACL$, $32 \times 32 \rightarrow 32$ bits	0000nnnnmmmm0111	—	2(to 5)*	—
MULS.W Rm, Rn	Signed operation of $Rn \times Rm \rightarrow MACL$, $16 \times 16 \rightarrow 32$ bits	0010nnnnmmmm1111	—	1(to 3)*	—
MULU.W Rm, Rn	Unsigned operation of $Rn \times Rm \rightarrow MACL$, $16 \times 16 \rightarrow 32$ bits	0010nnnnmmmm1110	—	1(to 3)*	—

Instruction		Operation	Code	Privileged Mode	Cycles	T Bit
NEG	Rm, Rn	0-Rm → Rn	0110nnnnnnmmmm1011	—	1	—
NEGC	Rm, Rn	0-Rm-T → Rn, Borrow → T	0110nnnnnnmmmm1010	—	1	Borrow
SUB	Rm, Rn	Rn-Rm → Rn	0011nnnnnnmmmm1000	—	1	—
SUBC	Rm, Rn	Rn-Rm-T → Rn, Borrow → T	0011nnnnnnmmmm1010	—	1	Borrow
SUBV	Rm, Rn	Rn-Rm → Rn, Underflow → T	0011nnnnnnmmmm1011	—	1	Underflow

Note: * The normal number of execution cycles is shown. The value in parentheses is the number of cycles required in case of contention with the preceding or following instruction.

Table 2.8 lists the SH7709S logic operation instructions.

Table 2.8 Logic Operation Instructions

Instruction		Operation	Code	Privileged Mode	Cycles	T Bit
AND	Rm, Rn	$Rn \& Rm \rightarrow Rn$	0010nrrrrrrrrrrrr1001	—	1	—
AND	#imm, R0	$R0 \& imm \rightarrow R0$	11001001iiiiiiii	—	1	—
AND.B	#imm, @(R0, GBR)	$(R0 + GBR) \& imm \rightarrow (R0 + GBR)$	11001101iiiiiiii	—	3	—
NOT	Rm, Rn	$\sim Rm \rightarrow Rn$	0110nrrrrrrrrrr0111	—	1	—
OR	Rm, Rn	$Rn Rm \rightarrow Rn$	0010nrrrrrrrrrr1011	—	1	—
OR	#imm, R0	$R0 imm \rightarrow R0$	11001011iiiiiiii	—	1	—
OR.B	#imm, @(R0, GBR)	$(R0 + GBR) imm \rightarrow (R0 + GBR)$	11001111iiiiiiii	—	3	—
TAS.B	@Rn	If (Rn) is 0, $1 \rightarrow T$; $1 \rightarrow$ MSB of (Rn)	0100nrrrr00011011	—	3	Test result
TST	Rm, Rn	$Rn \& Rm$; if the result is 0, $1 \rightarrow T$	0010nrrrrrrrrrr1000	—	1	Test result
TST	#imm, R0	$R0 \& imm$; if the result is 0, $1 \rightarrow T$	11001000iiiiiiii	—	1	Test result
TST.B	#imm, @(R0, GBR)	$(R0 + GBR) \& imm$; if the result is 0, $1 \rightarrow T$	11001100iiiiiiii	—	3	Test result
XOR	Rm, Rn	$Rn \wedge Rm \rightarrow Rn$	0010nrrrrrrrrrr1010	—	1	—
XOR	#imm, R0	$R0 \wedge imm \rightarrow R0$	11001010iiiiiiii	—	1	—
XOR.B	#imm, @(R0, GBR)	$(R0 + GBR) \wedge imm \rightarrow (R0 + GBR)$	11001110iiiiiiii	—	3	—

Table 2.9 lists the SH7709S shift instructions.

Table 2.9 Shift Instructions

Instruction		Operation	Code	Privileged Mode	Cycles	T Bit
ROTL	Rn	$T \leftarrow Rn \leftarrow \text{MSB}$	0100nnnn00000100	—	1	MSB
ROTR	Rn	$\text{LSB} \rightarrow Rn \rightarrow T$	0100nnnn00000101	—	1	LSB
ROTCL	Rn	$T \leftarrow Rn \leftarrow T$	0100nnnn00100100	—	1	MSB
ROTCR	Rn	$T \rightarrow Rn \rightarrow T$	0100nnnn00100101	—	1	LSB
SHAD	Rm, Rn	$Rn \geq 0: Rn \ll Rm \rightarrow Rn$ $Rn < 0: Rn \gg Rm \rightarrow$ $[\text{MSB} \rightarrow Rn]$	0100nnnnnnmm1100	—	1	—
SHAL	Rn	$T \leftarrow Rn \leftarrow 0$	0100nnnn00100000	—	1	MSB
SHAR	Rn	$\text{MSB} \rightarrow Rn \rightarrow T$	0100nnnn00100001	—	1	LSB
SHLD	Rm, Rn	$Rn \geq 0: Rn \ll Rm \rightarrow Rn$ $Rn < 0: Rn \gg Rm \rightarrow$ $[0 \rightarrow Rn]$	0100nnnnnnmm1101	—	1	—
SHLL	Rn	$T \leftarrow Rn \leftarrow 0$	0100nnnn00000000	—	1	MSB
SHLR	Rn	$0 \rightarrow Rn \rightarrow T$	0100nnnn00000001	—	1	LSB
SHLL2	Rn	$Rn \ll 2 \rightarrow Rn$	0100nnnn00001000	—	1	—
SHLR2	Rn	$Rn \gg 2 \rightarrow Rn$	0100nnnn00001001	—	1	—
SHLL8	Rn	$Rn \ll 8 \rightarrow Rn$	0100nnnn00011000	—	1	—
SHLR8	Rn	$Rn \gg 8 \rightarrow Rn$	0100nnnn00011001	—	1	—
SHLL16	Rn	$Rn \ll 16 \rightarrow Rn$	0100nnnn00101000	—	1	—
SHLR16	Rn	$Rn \gg 16 \rightarrow Rn$	0100nnnn00101001	—	1	—

Table 2.10 lists the SH7709S branch instructions.

Table 2.10 Branch Instructions

Instruction		Operation	Code	Privileged Mode	Cycles	T Bit
BF	label	If T = 0, disp × 2 + PC → PC; if T = 1, nop	10001011dddddddd	—	3/1*	—
BF/S	label	Delayed branch, if T = 0, disp × 2 + PC → PC; if T = 1, nop	10001111dddddddd	—	2/1*	—
BT	label	if T = 1, disp × 2 + PC → PC; if T = 0, nop	10001001dddddddd	—	3/1*	—
BT/S	label	Delayed branch, If T = 1, disp × 2 + PC → PC; if T = 0, nop	10001101dddddddd	—	2/1*	—
BRA	label	Delayed branch, disp × 2 + PC → PC	1010dddddddddddd	—	2	—
BRAF	Rm	Delayed branch, Rm + PC → PC	0000mmmm00100011	—	2	—
BSR	label	Delayed branch, PC → PR, disp × 2 + PC → PC	1011dddddddddddd	—	2	—
BSRF	Rm	Delayed branch, PC → PR, Rm + PC → PC	0000mmmm00000011	—	2	—
JMP	@Rm	Delayed branch, Rm → PC	0100mmmm00101011	—	2	—
JSR	@Rm	Delayed branch, PC → PR, Rm → PC	0100mmmm00001011	—	2	—
RTS		Delayed branch, PR → PC	0000000000001011	—	2	—

Note: * One state when there is no branch.

Table 2.11 lists the SH7709S system control instructions.

Table 2.11 System Control Instructions

Instruction		Operation	Code	Privileged Mode	Cycles	T Bit
CLRMACH		0 → MACH, MACL	0000000000101000	—	1	—
CLRS		0 → S	0000000001001000	—	1	—
CLRT		0 → T	0000000000001000	—	1	0
LDC	Rm, SR	Rm → SR	0100mmmm00001110	√	5	LSB
LDC	Rm, GBR	Rm → GBR	0100mmmm00011110	—	3	—
LDC	Rm, VBR	Rm → VBR	0100mmmm00101110	√	3	—
LDC	Rm, SSR	Rm → SSR	0100mmmm00111110	√	3	—
LDC	Rm, SPC	Rm → SPC	0100mmmm01001110	√	3	—
LDC	Rm, R0_BANK	Rm → R0_BANK	0100mmmm10001110	√	3	—
LDC	Rm, R1_BANK	Rm → R1_BANK	0100mmmm10011110	√	3	—
LDC	Rm, R2_BANK	Rm → R2_BANK	0100mmmm10101110	√	3	—
LDC	Rm, R3_BANK	Rm → R3_BANK	0100mmmm10111110	√	3	—
LDC	Rm, R4_BANK	Rm → R4_BANK	0100mmmm11001110	√	3	—
LDC	Rm, R5_BANK	Rm → R5_BANK	0100mmmm11011110	√	3	—
LDC	Rm, R6_BANK	Rm → R6_BANK	0100mmmm11101110	√	3	—
LDC	Rm, R7_BANK	Rm → R7_BANK	0100mmmm11111110	√	3	—
LDC.L	@Rm+, SR	(Rm) → SR, Rm + 4 → Rm	0100mmmm00000111	√	7	LSB
LDC.L	@Rm+, GBR	(Rm) → GBR, Rm + 4 → Rm	0100mmmm00010111	—	5	—
LDC.L	@Rm+, VBR	(Rm) → VBR, Rm + 4 → Rm	0100mmmm00100111	√	5	—
LDC.L	@Rm+, SSR	(Rm) → SSR, Rm + 4 → Rm	0100mmmm00110111	√	5	—
LDC.L	@Rm+, SPC	(Rm) → SPC, Rm + 4 → Rm	0100mmmm01000111	√	5	—
LDC.L	@Rm+, R0_BANK	(Rm) → R0_BANK, Rm + 4 → Rm	0100mmmm10000111	√	5	—
LDC.L	@Rm+, R1_BANK	(Rm) → R1_BANK, Rm + 4 → Rm	0100mmmm10010111	√	5	—
LDC.L	@Rm+, R2_BANK	(Rm) → R2_BANK, Rm + 4 → Rm	0100mmmm10100111	√	5	—
LDC.L	@Rm+, R3_BANK	(Rm) → R3_BANK, Rm + 4 → Rm	0100mmmm10110111	√	5	—
LDC.L	@Rm+, R4_BANK	(Rm) → R4_BANK, Rm + 4 → Rm	0100mmmm11000111	√	5	—
LDC.L	@Rm+, R5_BANK	(Rm) → R5_BANK, Rm + 4 → Rm	0100mmmm11010111	√	5	—

Instruction	Operation	Code	Privileged Mode	Cycles	T Bit
LDC.L @Rm+, R6_BANK	(Rm) → R6_BANK, Rm + 4 → Rm	0100mmmm111100111	√	5	—
LDC.L @Rm+, R7_BANK	(Rm) → R7_BANK, Rm + 4 → Rm	0100mmmm111101111	√	5	—
LDS Rm, MACH	Rm → MACH	0100mmmm00001010	—	1	—
LDS Rm, MACL	Rm → MACL	0100mmmm00011010	—	1	—
LDS Rm, PR	Rm → PR	0100mmmm00101010	—	1	—
LDS.L @Rm+, MACH	(Rm) → MACH, Rm + 4 → Rm	0100mmmm00000110	—	1	—
LDS.L @Rm+, MACL	(Rm) → MACL, Rm + 4 → Rm	0100mmmm00010110	—	1	—
LDS.L @Rm+, PR	(Rm) → PR, Rm + 4 → Rm	0100mmmm00100110	—	1	—
LDTLB	PTEH/PTEL → TLB	000000000111000	√	1	—
NOP	No operation	000000000001001	—	1	—
PREF @Rm	(Rm) → cache	0000mmmm10000011	—	2	—
RTE	Delayed branch, SSR → SR, SPC → PC	000000000101011	√	4	—
SETS	1 → S	000000001011000	—	1	—
SETT	1 → T	000000000011000	—	1	1
SLEEP	Sleep	000000000011011	√	4*	—
STC SR, Rn	SR → Rn	0000nnnn00000010	√	1	—
STC GBR, Rn	GBR → Rn	0000nnnn00010010	—	1	—
STC VBR, Rn	VBR → Rn	0000nnnn00100010	√	1	—
STC SSR, Rn	SSR → Rn	0000nnnn00110010	√	1	—
STC SPC, Rn	SPC → Rn	0000nnnn01000010	√	1	—
STC R0_BANK, Rn	R0_BANK → Rn	0000nnnn10000010	√	1	—
STC R1_BANK, Rn	R1_BANK → Rn	0000nnnn10010010	√	1	—
STC R2_BANK, Rn	R2_BANK → Rn	0000nnnn10100010	√	1	—
STC R3_BANK, Rn	R3_BANK → Rn	0000nnnn10110010	√	1	—
STC R4_BANK, Rn	R4_BANK → Rn	0000nnnn11000010	√	1	—
STC R5_BANK, Rn	R5_BANK → Rn	0000nnnn11010010	√	1	—
STC R6_BANK, Rn	R6_BANK → Rn	0000nnnn11100010	√	1	—
STC R7_BANK, Rn	R7_BANK → Rn	0000nnnn11110010	√	1	—
STC.L SR, @-Rn	Rn-4 → Rn, SR → (Rn)	0100nnnn00000011	√	2	—
STC.L GBR, @-Rn	Rn-4 → Rn, GBR → (Rn)	0100nnnn00010011	—	2	—
STC.L VBR, @-Rn	Rn-4 → Rn, VBR → (Rn)	0100nnnn00100011	√	2	—

Note: * The number of cycles until the sleep state is entered.

Instruction	Operation	Code	Privileged Mode	Cycles	T Bit
STC.L SSR, @-Rn	Rn-4 → Rn, SSR → (Rn)	0100nnnn00110011	√	2	—
STC.L SPC, @-Rn	Rn-4 → Rn, SPC → (Rn)	0100nnnn01000011	√	2	—
STC.L R0_BANK, @-Rn	Rn-4 → Rn, R0_BANK → (Rn)	0100nnnn10000011	√	2	—
STC.L R1_BANK, @-Rn	Rn-4 → Rn, R1_BANK → (Rn)	0100nnnn10010011	√	2	—
STC.L R2_BANK, @-Rn	Rn-4 → Rn, R2_BANK → (Rn)	0100nnnn10100011	√	2	—
STC.L R3_BANK, @-Rn	Rn-4 → Rn, R3_BANK → (Rn)	0100nnnn10110011	√	2	—
STC.L R4_BANK, @-Rn	Rn-4 → Rn, R4_BANK → (Rn)	0100nnnn11000011	√	2	—
STC.L R5_BANK, @-Rn	Rn-4 → Rn, R5_BANK → (Rn)	0100nnnn11010011	√	2	—
STC.L R6_BANK, @-Rn	Rn-4 → Rn, R6_BANK → (Rn)	0100nnnn11100011	√	2	—
STC.L R7_BANK, @-Rn	Rn-4 → Rn, R7_BANK → (Rn)	0100nnnn11110011	√	2	—
STS MACH, Rn	MACH → Rn	0000nnnn00001010	—	1	—
STS MACL, Rn	MACL → Rn	0000nnnn00011010	—	1	—
STS PR, Rn	PR → Rn	0000nnnn00101010	—	1	—
STS.L MACH, @-Rn	Rn-4 → Rn, MACH → (Rn)	0100nnnn00000010	—	1	—
STS.L MACL, @-Rn	Rn-4 → Rn, MACL → (Rn)	0100nnnn00010010	—	1	—
STS.L PR, @-Rn	Rn-4 → Rn, PR → (Rn)	0100nnnn00100010	—	1	—
TRAPA #imm	PC → SPC, SR → SSR, imm → TRA	11000011iiiiiiii	—	8	—

- Notes: 1. The table shows the minimum number of execution cycles. The actual number of instruction execution cycles will increase in cases such as the following:
- When there is contention between an instruction fetch and data access
 - When the destination register in a load (memory-to-register) instruction is also used by the next instruction
2. With the addressing modes using displacement (disp) listed below, the assembler descriptions in this manual show the value before scaling (×1, ×2, or ×4) is performed. This is done to clarify the operation of the chip. For the actual assembler descriptions, refer to the individual assembler notation rules.
- @ (disp:4, Rn) ; Register-indirect with displacement
 @ (disp:8, Rn) ; GBR-indirect with displacement
 @ (disp:8, PC) ; PC-relative with displacement
 disp:8, disp:12 ; PC-relative

2.4.2 Instruction Code Map

Table 2.12 shows the instruction code map.

Table 2.12 Instruction Code Map

Instruction Code				Fx: 0000	Fx: 0001	Fx: 0010	Fx: 0011 to 1111
MSB	LSB			MD: 00	MD: 01	MD: 10	MD: 11
0000	Rn	Fx	0000				
0000	Rn	Fx	0001				
0000	Rn	00MD	0010	STC SR,Rn	STC GBR,Rn	STC VBR,Rn	STC SSR,Rn
0000	Rn	01MD	0010	STC SPC,Rn			
0000	Rn	10MD	0010	STC R0_BANK,Rn	STC R1_BANK,Rn	STC R2_BANK,Rn	STC R3_BANK,Rn
0000	Rn	11MD	0010	STC R4_BANK,Rn	STC R5_BANK,Rn	STC R6_BANK,Rn	STC R7_BANK,Rn
0000	Rm	00MD	0011	BSRF Rm		BRAF Rm	
0000	Rn	10MD	0011	PREF @Rn			
0000	Rn	Rm	01MD	MOV.B Rm,@(R0,Rn)	MOV.W Rm,@(R0,Rn)	MOV.L Rm,@(R0,Rn)	MUL.L Rm,Rn
0000	0000	00MD	1000	CLRT	SETT	CLRMAC	LDTLB
0000	0000	01MD	1000	CLRS	SETS		
0000	0000	Fx	1001	NOP	DIV0U		
0000	0000	Fx	1010				
0000	0000	Fx	1011	RTS	SLEEP	RTE	
0000	Rn	Fx	1000				
0000	Rn	Fx	1001			MOVT Rn	
0000	Rn	Fx	1010	STS MACH,Rn	STS MACL,Rn	STS PR,Rn	
0000	Rn	Fx	1011				
0000	Rn	Rm	11MD	MOV.B @(R0,Rm),Rn	MOV.W @(R0,Rm),Rn	MOV.L @(R0,Rm),Rn	MAC.L @Rm+,@Rn+
0001	Rn	Rm	disp	MOV.L Rm,@(disp:4,Rn)			
0010	Rn	Rm	00MD	MOV.B Rm,@Rn	MOV.W Rm,@Rn	MOV.L Rm,@Rn	
0010	Rn	Rm	01MD	MOV.B Rm,@-Rn	MOV.W Rm,@-Rn	MOV.L Rm,@-Rn	DIV0S Rm,Rn
0010	Rn	Rm	10MD	TST Rm,Rn	AND Rm,Rn	XOR Rm,Rn	OR Rm,Rn
0010	Rn	Rm	11MD	CMP/STR Rm,Rn	XTRCT Rm,Rn	MULU.W Rm,Rn	MULSW Rm,Rn
0011	Rn	Rm	00MD	CMP/EQ Rm,Rn		CMP/HS Rm,Rn	CMP/GE Rm,Rn
0011	Rn	Rm	01MD	DIV1 Rm,Rn	DMULU.LRm,Rn	CMP/HI Rm,Rn	CMP/GT Rm,Rn
0011	Rn	Rm	10MD	SUB Rm,Rn		SUBC Rm,Rn	SUBV Rm,Rn
0011	Rn	Rm	11MD	ADD Rm,Rn	DMULS.LRm,Rn	ADDC Rm,Rn	ADDV Rm,Rn

Instruction Code				Fx: 0000		Fx: 0001		Fx: 0010		Fx: 0011 to 1111	
MSB		LSB		MD: 00		MD: 01		MD: 10		MD: 11	
0100	Rn	Fx	0000	SHLL	Rn	DT	Rn	SHAL	Rn		
0100	Rn	Fx	0001	SHLR	Rn	CMP/PZ	Rn	SHAR	Rn		
0100	Rn	Fx	0010	STS.L	MACH,@-Rn	STS.L	MACL,@-Rn	STS.L	PR,@-Rn		
0100	Rn	00MD	0011	STC.L	SR,@-Rn	STC.L	GBR,@-Rn	STC.L	VBR,@-Rn	STC.L	SSR,@-Rn
0100	Rn	01MD	0011	STC.L	SPC,@-Rn						
0100	Rn	10MD	0011	STC.L	R0_BANK,@-Rn	STC.L	R1_BANK,@-Rn	STC.L	R2_BANK,@-Rn	STC.L	R3_BANK,@-Rn
0100	Rn	11MD	0011	STC.L	R4_BANK,@-Rn	STC.L	R5_BANK,@-Rn	STC.L	R6_BANK,@-Rn	STC.L	R7_BANK,@-Rn
0100	Rn	Fx	0100	ROTL	Rn			ROTCL	Rn		
0100	Rn	Fx	0101	ROTR	Rn	CMP/PL	Rn	ROTCR	Rn		
0100	Rm	Fx	0110	LDS.L	@Rm+,MACH	LDS.L	@Rm+,MACL	LDS.L	@Rm+,PR		
0100	Rm	00MD	0111	LDC.L	@Rm+,SR	LDC.L	@Rm+,GBR	LDC.L	@Rm+,VBR	LDC.L	@Rm+,SSR
0100	Rm	01MD	0111	LDC.L	@Rm+,SPC						
0100	Rm	10MD	0111	LDC.L	@Rm+,R0_BANK	LDC.L	@Rm+,R1_BANK	LDC.L	@Rm+,R2_BANK	LDC.L	@Rm+,R3_BANK
0100	Rm	11MD	0111	LDC.L	@Rm+,R4_BANK	LDC.L	@Rm+,R5_BANK	LDC.L	@Rm+,R6_BANK	LDC.L	@Rm+,R7_BANK
0100	Rn	Fx	1000	SHLL2	Rn	SHLL8	Rn	SHLL16	Rn		
0100	Rn	Fx	1001	SHLR2	Rn	SHLR8	Rn	SHLR16	Rn		
0100	Rm	Fx	1010	LDS	Rm,MACH	LDS	Rm,MACL	LDS	Rm,PR		
0100	Rm/ Rn	Fx	1011	JSR	@Rm	TAS.B	@Rn	JMP	@Rm		
0100	Rn	Rm	1100	SHAD	Rm,Rn						
0100	Rn	Rm	1101	SHLD	Rm,Rn						
0100	Rm	00MD	1110	LDC	Rm,SR	LDC	Rm,GBR	LDC	Rm,VBR	LDC	Rm,SSR
0100	Rm	01MD	1110	LDC	Rm,SPC						
0100	Rm	10MD	1110	LDC	Rm,R0_BANK	LDC	Rm,R1_BANK	LDC	Rm,R2_BANK	LDC	Rm,R3_BANK
0100	Rm	11MD	1110	LDC	Rm,R4_BANK	LDC	Rm,R5_BANK	LDC	Rm,R6_BANK	LDC	Rm,R7_BANK
0100	Rn	Rm	1111	MAC.W	@Rm+,@Rn+						
0101	Rn	Rm	disp	MOV.L	@(disp:4,Rm),Rn						
0110	Rn	Rm	00MD	MOV.B	@Rm,Rn	MOV.W	@Rm,Rn	MOV.L	@Rm,Rn	MOV	Rm,Rn
0110	Rn	Rm	01MD	MOV.B	@Rm+,Rn	MOV.W	@Rm+,Rn	MOV.L	@Rm+,Rn	NOT	Rm,Rn
0110	Rn	Rm	10MD	SWAP.B	Rm,Rn	SWAP.W	Rm,Rn	NEGC	Rm,Rn	NEG	Rm,Rn
0110	Rn	Rm	11MD	EXTU.B	Rm,Rn	EXTU.W	Rm,Rn	EXTS.B	Rm,Rn	EXTS.W	Rm,Rn
0111	Rn	imm		ADD	#imm:8,Rn						

Instruction Code				Fx: 0000	Fx: 0001	Fx: 0010	Fx: 0011 to 1111
MSB	LSB			MD: 00	MD: 01	MD: 10	MD: 11
1000	00MD	Rn	disp	MOV.B R0,@(disp:4,Rn)	MOV.W R0,@(disp:4,Rn)		
1000	01MD	Rm	disp	MOV.B @(disp:4,Rm),R0	MOV.W @(disp:4,Rm),R0		
1000	10MD	imm/disp		CMP/EQ #imm:8,R0	BT label:8		BF label:8
1000	11MD	imm/disp			BT/S label:8		BF/S label:8
1001	Rn	disp		MOV.W @(DISP:8,PC),Rn			
1010		disp		BRA label:12			
1011		disp		BSR label:12			
1100	00MD	imm/disp		MOV.B R0,@(disp:8,GBR)	MOV.W R0,@(disp:8,GBR)	MOV.L R0,@(disp:8,GBR)	TRAPA #imm:8
1100	01MD	disp		MOV.B @(disp:8,GBR),R0	MOV.W @(disp:8,GBR),R0	MOV.L @(disp:8,GBR),R0	MOVA @(disp:8,PC),R0
1100	10MD	imm		TST #imm:8,R0	AND #imm:8,R0	XOR #imm:8,R0	OR #imm:8,R0
1100	11MD	imm		TST.B #imm:8,@(R0,GBR)	AND.B #imm:8,@(R0,GBR)	XOR.B #imm:8,@(R0,GBR)	OR.B #imm:8,@(R0,GBR)
1101	Rn	disp		MOV.L @(disp:8,PC),Rn			
1110	Rn	imm		MOV #imm:8,Rn			
1111	*****						

Note: See the SH-3/SH-3E/SH3-DSP Programming Manual for details.

2.5 Processor States and Processor Modes

2.5.1 Processor States

The SH7709S has five processor states: the reset state, exception-handling state, bus-released state, program execution state, and power-down state.

Reset State: In this state the CPU is reset. The CPU enters the power-on reset state if the $\overline{\text{RESETP}}$ pin is low, or the manual reset state if the $\overline{\text{RESETM}}$ pin is low. See section 4, Exception Handling, for more information on resets.

In the power-on reset state, the internal states of the CPU and the on-chip supporting module registers are initialized. In the manual reset state, the internal states of the CPU and registers of on-chip supporting modules other than the bus state controller (BSC) are initialized. Refer to the register configurations in the relevant sections for further details.

Exception-Handling State: This is a transient state during which the CPU's processor state flow is altered by a reset, general exception, or interrupt exception handling.

In the case of a reset, the CPU branches to address H'A0000000 and starts executing the user-coded exception handling program.

In the case of a general exception or interrupt, the program counter (PC) contents are saved in the saved program counter (SPC) and the status register (SR) contents are saved in the saved status register (SSR). The CPU branches to the start address of the user-coded exception service routine found from the sum of the contents of the vector base address and the vector offset. See section 4, Exception Processing, for more information on resets, general exceptions, and interrupts.

Program Execution State: In this state the CPU executes program instructions in sequence.

Power-Down State: In the power-down state, CPU operation halts and power consumption is reduced. There are two modes in the power-down state: sleep mode, and standby mode. See section 8, Power-Down Modes, for more information.

Bus-Released State: In this state the CPU has released the bus to a device that requested it.

Transitions between the states are shown in figure 2.8.

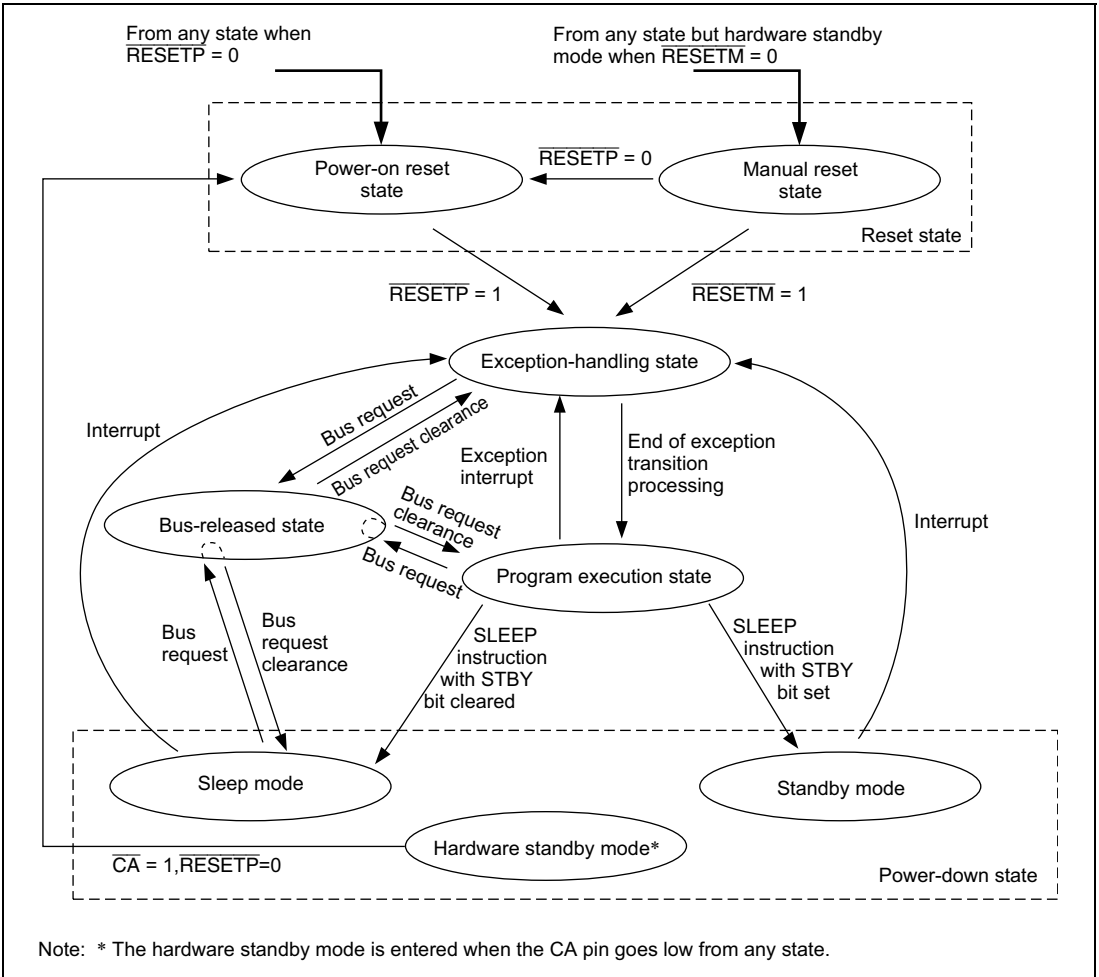

Figure 2.8 Processor State Transitions

2.5.2 Processor Modes

There are two processor modes: privileged mode and user mode. The processor mode is determined by the processor mode bit (MD) in the status register (SR). User mode is selected when the MD bit is 0, and privileged mode when the MD bit is 1. When the reset state or exception state is entered, the MD bit is set to 1. When exception handling ends, the MD bit is cleared to 0 and user mode is entered. There are certain registers and bits which can only be accessed in privileged mode.

Section 3 Memory Management Unit (MMU)

3.1 Overview

3.1.1 Features

The SH7709S has an on-chip memory management unit (MMU) that implements address translation. The SH7709S features a resident translation look-aside buffer (TLB) that caches information for user-created address translation tables located in external memory. It enables high-speed translation of virtual addresses into physical addresses. Address translation uses the paging system and supports two page sizes (1 kbytes and 4 kbytes). The access right to virtual address space can be set for privileged and user modes to provide memory protection.

3.1.2 Role of MMU

The MMU is a feature designed to make efficient use of physical memory. As shown in figure 3.1, if a process is smaller in size than the physical memory, the entire process can be mapped onto physical memory. However, if the process increases in size to the extent that it no longer fits into physical memory, it becomes necessary to partition the process and to map those parts requiring execution onto memory as occasion demands ((1)). Having the process itself consider this mapping onto physical memory would impose a large burden on the process. To lighten this burden, the idea of virtual memory was born as a means of performing en bloc mapping onto physical memory ((2)). In a virtual memory system, substantially more virtual memory than physical memory is provided, and the process is mapped onto this virtual memory. Thus a process only has to consider operation in virtual memory. Mapping from virtual memory to physical memory is handled by the MMU. The MMU is normally controlled by the operating system, switching physical memory to allow the virtual memory required by a process to be mapped onto physical memory in a smooth fashion. Switching of physical memory is carried out via secondary storage, etc.

The virtual memory system that came into being in this way is particularly effective in a time-sharing system (TSS) in which a number of processes are running simultaneously ((3)). If processes running in a TSS had to take mapping onto virtual memory into consideration while running, it would not be possible to increase efficiency. Virtual memory is thus used to reduce this load on the individual processes and so improve efficiency ((4)). In the virtual memory system, virtual memory is allocated to each process. The task of the MMU is to perform efficient mapping of these virtual memory areas onto physical memory. It also has a memory protection feature that prevents one process from inadvertently accessing another process's physical memory.

When address translation from virtual memory to physical memory is performed using the MMU, it may occur that the relevant translation information is not recorded in the MMU, with the result that one process may inadvertently access the virtual memory allocated to another process. In this

case, the MMU will generate an exception, change the physical memory mapping, and record the new address translation information.

Although the functions of the MMU could also be implemented by software alone, the need for translation to be performed by software each time a process accesses physical memory would result in poor efficiency. For this reason, a buffer for address translation (translation look-aside buffer: TLB) is provided in hardware to hold frequently used address translation information. The TLB can be described as a cache for storing address translation information. Unlike cache memory, however, if address translation fails, that is, if an exception is generated, switching of address translation information is normally performed by software. This makes it possible for memory management to be performed flexibly by software.

The MMU has two methods of mapping from virtual memory to physical memory: a paging method using fixed-length address translation, and a segment method using variable-length address translation. With the paging method, the unit of translation is a fixed-size address space (usually of 1 to 64 kbytes) called a page. This LSI uses the paging method.

In the following text, the SH7709S address space in virtual memory is referred to as virtual address space, and address space in physical memory as physical memory space.

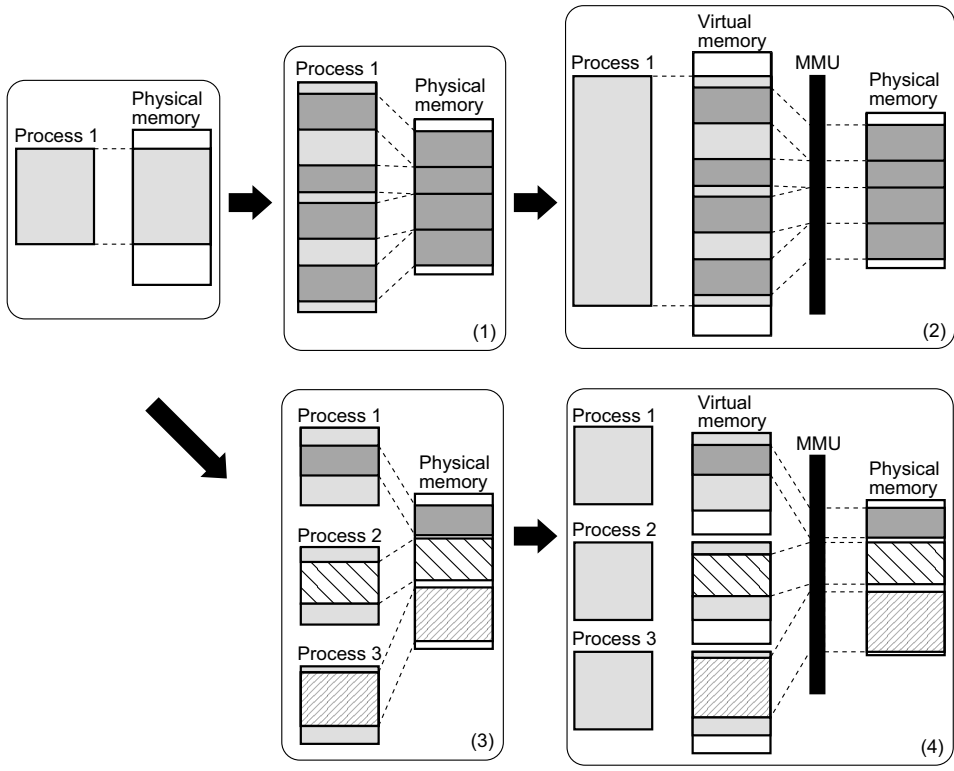

Figure 3.1 MMU Functions

3.1.3 SH7709S MMU

Virtual Address Space: The SH7709S uses 32-bit virtual addresses to access a 4-Gbyte virtual address space that is divided into several areas. Address space mapping is shown in figure 3.2.

- Privileged Mode

In privileged mode, there are five areas, P0–P4. The P0 and P3 areas are mapped onto physical address space in page units, in accordance with address translation table information. Write-back or write-through can be selected for write access by means of a cache control register (CCR) setting.

Mapping of the P1 area is fixed in physical address space (H'00000000 to H'1FFFFFFF). In the P1 area, setting a virtual address MSB (bit 31) to 0 generates the corresponding physical address. P1 area accesses can be cached, and the cache control register (CCR) is set to indicate whether to cache or not. Write-back or write-through mode can be selected.

Mapping of the P2 area is fixed in physical address space (H'00000000 to H'1FFFFFFF). In the P2 area, setting the top three virtual address bits (bits 31, 30, and 29) to 0 generates the corresponding physical address. P2 area access cannot be cached.

The P1 and P2 areas are not mapped by the address translation table, so the TLB is not used and no exceptions such as TLB misses occur. Initialization of MMU control registers, exception handling routines, and the like should be located in the P1 and P2 areas. Routines that require high-speed processing should be placed in the P1 area, since it can be cached.

Some peripheral module control registers are located in area 1 of the physical address space. When the physical address space is not used for address translation, these registers should be located in the P2 area. When address translation is to be used, set no caching.

The P4 area is used for mapping peripheral module register addresses, etc.

- User Mode

In user mode, 2 Gbytes of the virtual address space from H'00000000 to H'7FFFFFFF (area U0) can be accessed. U0 is mapped onto physical address space in page units, in accordance with address translation table information.

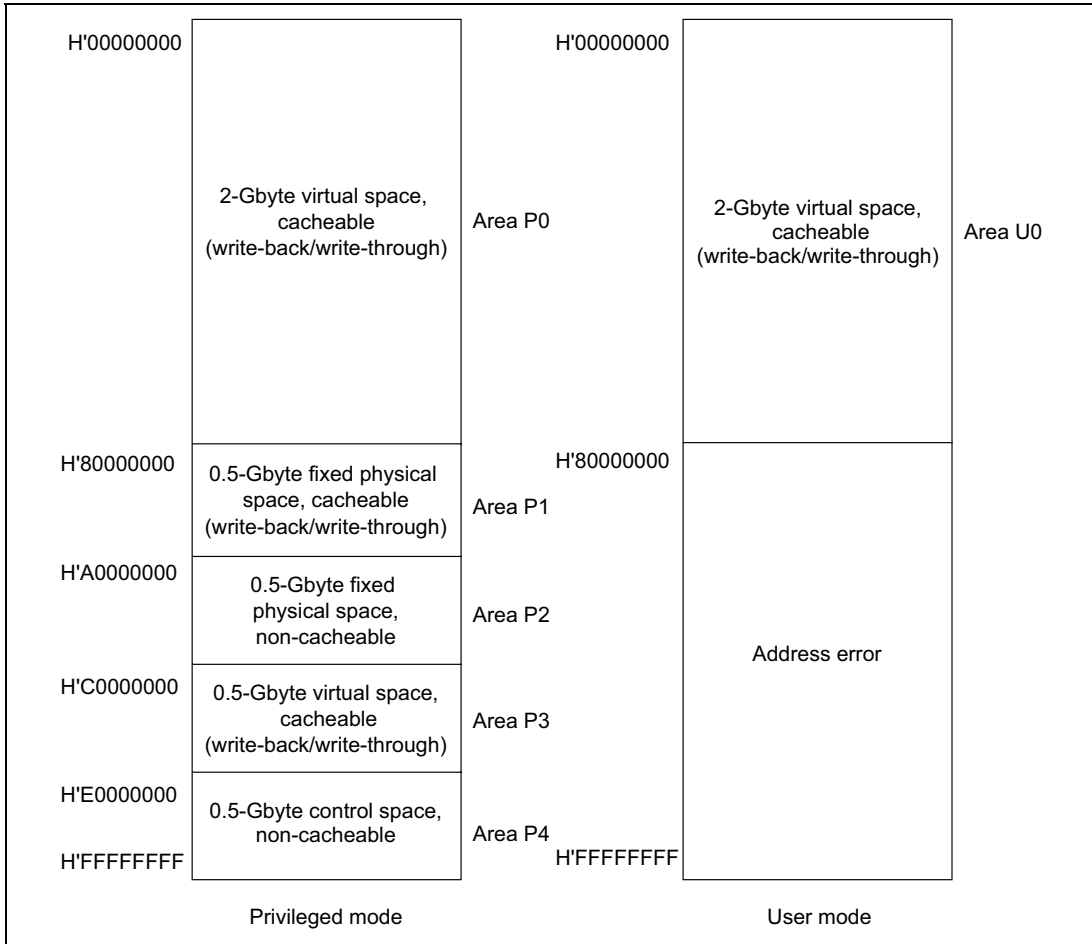

Figure 3.2 Virtual Address Space Mapping

Physical Address Space: The SH7709S supports a 32-bit physical address space, but the upper 3 bits are actually ignored and treated as a shadow. See section 10, Bus State Controller (BSC), for details.

Address Translation: When the MMU is enabled, the virtual address space is divided into units called pages. Physical addresses are translated in page units. Address translation tables in external memory hold information such as the physical address that corresponds to the virtual address and memory protection codes. When an access to an area other than P4 occurs, if the accessed virtual address belongs to area P1 or P2 there is no TLB access and the physical address is uniquely defined. If it belongs to area P0, P3, or U0, the TLB is searched by virtual address and, if that virtual address is registered in the TLB, the access hits the TLB. The corresponding physical address and the page control information are read from the TLB and the physical address is determined.

If the virtual address is not registered in the TLB, a TLB miss exception occurs and processing will shift to the TLB miss handler. In the TLB miss handler, the TLB address translation table in external memory is searched and the corresponding physical address and the page control information are registered in the TLB. After returning from the handler, the instruction that caused the TLB miss is re-executed. When the MMU is enabled, address translation information that results in a physical address space of H'80000000–H'FFFFFFF should not be registered in the TLB.

When the MMU is disabled, the virtual address is used directly as the physical address. As the SH7709S supports a 29-bit address space as the physical address space, the top 3 bits of the physical address are ignored, and constitute a shadow space (see section 10, Bus State Controller (BSC)). For example, addresses H'00001000 in the P0 area, H'80001000 in the P1 area, H'A0001000 in the P2 area, and H'C0001000 in the P3 area are all mapped onto the same physical address. When access to these addresses is performed with the cache enabled, an address with the top 3 bits of the physical address masked to 0 is stored in the cache address array to ensure data congruity.

Single Virtual Memory Mode and Multiple Virtual Memory Mode: There are two virtual memory modes: single virtual memory mode and multiple virtual memory mode. In single virtual memory mode, multiple processes run in parallel using the virtual address space exclusively and the physical address corresponding to a given virtual address is specified uniquely. In multiple virtual memory mode, multiple processes run in parallel sharing the virtual address space, so a given virtual address may be translated into different physical addresses depending on the process. Single or multiple virtual mode is selected by a value set in the MMU control register (MMUCR). In terms of operation, the only difference between single virtual memory mode and multiple virtual memory mode is in the TLB address comparison method (see section 3.3.3, TLB Address Comparison).

Address Space Identifier (ASID): In multiple virtual memory mode, the address space identifier (ASID) is used to differentiate between processes running in parallel and sharing virtual address space. The ASID is 8 bits in length and can be set by software setting of the ASID of the currently running process in the page table entry register high (PTEH) within the MMU. When the process is switched using the ASID, the TLB does not have to be purged.

In single virtual memory mode, the ASID is used to provide memory protection for processes running simultaneously and using the virtual address space exclusively (see section 3.4.2, MMU Software Management).

3.1.4 Register Configuration

A register that has an undefined initial value must be initialized by software. Table 3.1 shows the configuration of the MMU control registers.

Table 3.1 Register Configuration

Name	Abbreviation	R/W	Size	Initial Value*1	Address
Page table entry register high	PTEH	R/W	Longword	Undefined	H'FFFFFFF0
Page table entry register low	PTL	R/W	Longword	Undefined	H'FFFFFFF4
Translation table base register	TTB	R/W	Longword	Undefined	H'FFFFFFF8
TLB exception address register	TEA	R/W	Longword	Undefined	H'FFFFFFFC
MMU control register	MMUCR	R/W	Longword	*2	H'FFFFFFE0

Notes: 1. Initialized by a power-on reset or manual reset.
2. SV bit: undefined
Other bits: 0

3.2 Register Description

There are five registers for MMU processing. These registers are located in address space area P4 and can only be accessed from privileged mode by specifying the address.

1. The page table entry register high (PTEH) register residing at address H'FFFFFFF0, which consists of a virtual page number (VPN) and ASID. The VPN set is the VPN of the virtual address at which the exception is generated in case of an MMU exception or address error exception. When the page size is 4 kbytes, the VPN is the upper 20 bits of the virtual address, but in this case the upper 22 bits of the virtual address are set. The VPN can also be modified by software. As the ASID, software sets the number of the currently executing process. The VPN and ASID are recorded in the TLB by the LDTLB instruction.
2. The page table entry register low (PTL) register residing at address H'FFFFFFF4, and used to store the physical page number and page management information to be recorded in the TLB by the LDTLB instruction. The contents of this register are only modified in response to a software command. (Refer to section 3.4.3, MMU Instruction (LDTLB), and section 3.5, MMU Exceptions.)
3. The translation table base register (TTB) residing at address H'FFFFFFF8, which points to the base address of the current page table. The hardware does not set any value in TTB automatically. TTB is available to software for general purposes.
4. The TLB exception address register (TEA) residing at address H'FFFFFFFC, which stores the virtual address corresponding to a TLB or address error exception. This value remains valid until the next exception or interrupt.

5. The MMU control register (MMUCR) residing at address H'FFFFFFE0, which makes the MMU settings described in figure 3.3. Any program that modifies MMUCR should reside in the P1 or P2 area.

The MMU registers are shown in figure 3.3.

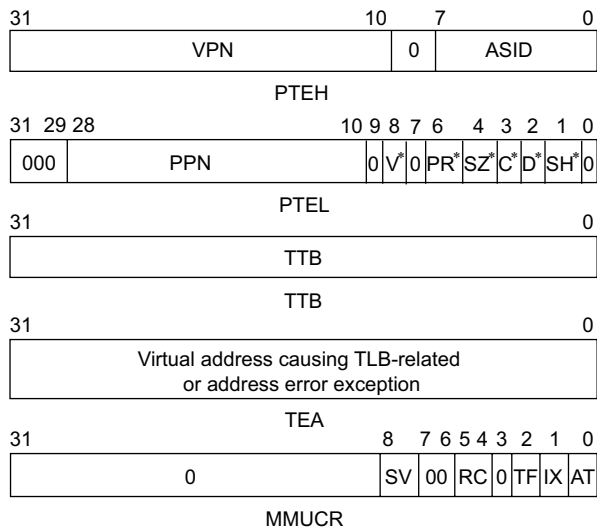

- 0: Reserved bits. Always read as 0. Writing is ignored. However, 0 should also be specified in a write to MMUCR only.
- SV: Single virtual memory mode bit. 0: Multiple virtual memory mode
1: Single virtual memory mode
- RC: A 2-bit random counter, automatically updated by hardware according to the following rules in the event of an MMU exception. When a TLB miss exception occurs, all TLB entry ways corresponding to the virtual address at which the exception occurred are checked, and if all ways are valid, 1 is added to RC; if there is one or more invalid way, they are set by priority from way 0, in the order: way 0, way 1, way 2, way 3. In the event of an MMU exception other than a TLB miss exception, the way which caused the exception is set in RC.
- TF: TLB flush bit. Write 1 to flush the TLB (clear all valid bits of the TLB to 0). Always reads 0.
- IX: Index mode bit. When 0, VPN bits 16–12 are used as the TLB index number. When 1, the value obtained by EX-ORing ASID bits 4–0 in PTEH and VPN bits 16–12 are used as the TLB index number.
- AT: Address translation bit. Enables/disables the MMU.
0: MMU disabled
1: MMU enabled

Note: * Refer to section 3.3, TLB Functions.

Figure 3.3 MMU Register Contents

3.3 TLB Functions

3.3.1 Configuration of the TLB

The TLB caches address translation table information located in the external memory. The address translation table stores the physical page number translated from the virtual page number and the control information for the page, which is the unit of address translation. Figure 3.4 shows the overall TLB configuration. The TLB is 4-way set associative with 128 entries. There are 32 entries for each way. Figure 3.5 shows the configuration of virtual addresses and TLB entries.

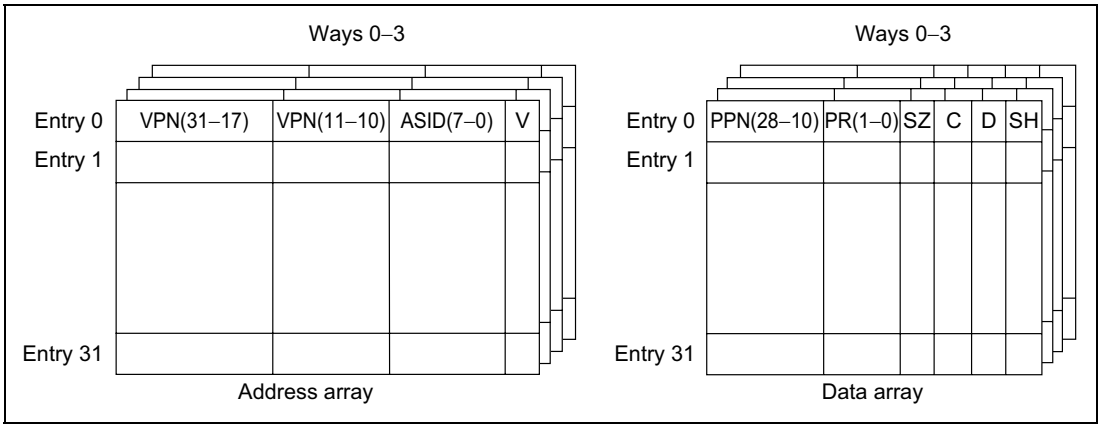
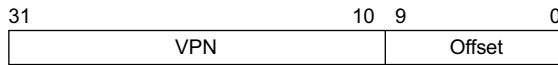

Figure 3.4 Overall Configuration of the TLB



Virtual address (1-kbyte page)



Virtual address (4-kbyte page)

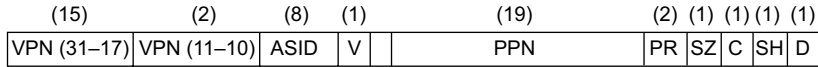

TLB entry

Legend:

- VPN: Virtual page number. Top 22 bits of virtual address for a 1-kbyte page, or top 20 bits of virtual address for a 4-kbyte page. Since VPN bits 16-12 are used as the index number, they are not stored in the TLB entry.
- ASID: Address space identifier. Indicates the process that can access a virtual page. In single virtual memory mode and user mode, or in multiple virtual memory mode, if the SH bit is 0, the address is compared with the ASID in PTEH when address comparison is performed.
- SH: Share status bit
 - 0 = Page not shared between processes
 - 1 = Page shared between processes
- SZ: Page-size bit
 - 0 = 1-kbyte page
 - 1 = 4-kbyte page
- V: Valid bit. Indicates whether entry is valid.
 - 0 = Invalid
 - 1 = Valid
 Cleared to 0 by a power-on reset. Not affected by a manual reset.
- PPN: Physical page number. Top 29 bits of physical address. PPN bits 11-10 are not used in case of a 4-kbyte page. Attention must be paid to the synonym problem in case of a 1-kbyte page (see section 3.4.4, Avoiding Synonym Problems).
- PR: Set the most significant bit to 0.
 - Protection key field. 2-bit field encoded to define the access rights to the page.
 - 00: Reading only is possible in privileged mode.
 - 01: Reading/writing is possible in privileged mode.
 - 10: Reading only is possible in privileged/user mode.
 - 11: Reading/writing is possible in privileged/user mode.
- C: Cacheable bit. Indicates whether the page is cacheable.
 - 0: Non-cacheable
 - 1: Cacheable
- D: Dirty bit. Indicates whether the page has been written to.
 - 0 = Not written to
 - 1 = Written to

Figure 3.5 Virtual Address and TLB Structure

3.3.2 TLB Indexing

The TLB uses a 4-way set associative scheme, so entries must be selected by index. VPN bits 16 to 12 and ASID bits 4 to 0 in PTEH are used as the index number regardless of the page size. The index number can be generated in two different ways depending on the setting of the IX bit in MMUCR.

1. When IX = 0, VPN bits 16–12 alone are used as the index number
2. When IX = 1, VPN bits 16–12 are EX-ORed with ASID bits 4–0 to generate a 5-bit index number

The second method is used to prevent lowered TLB efficiency that results when multiple processes run simultaneously in the same virtual address space (multiple virtual memory) and a specific entry is selected by generating an index number for each process. Figures 3.6 and 3.7 show the indexing schemes.

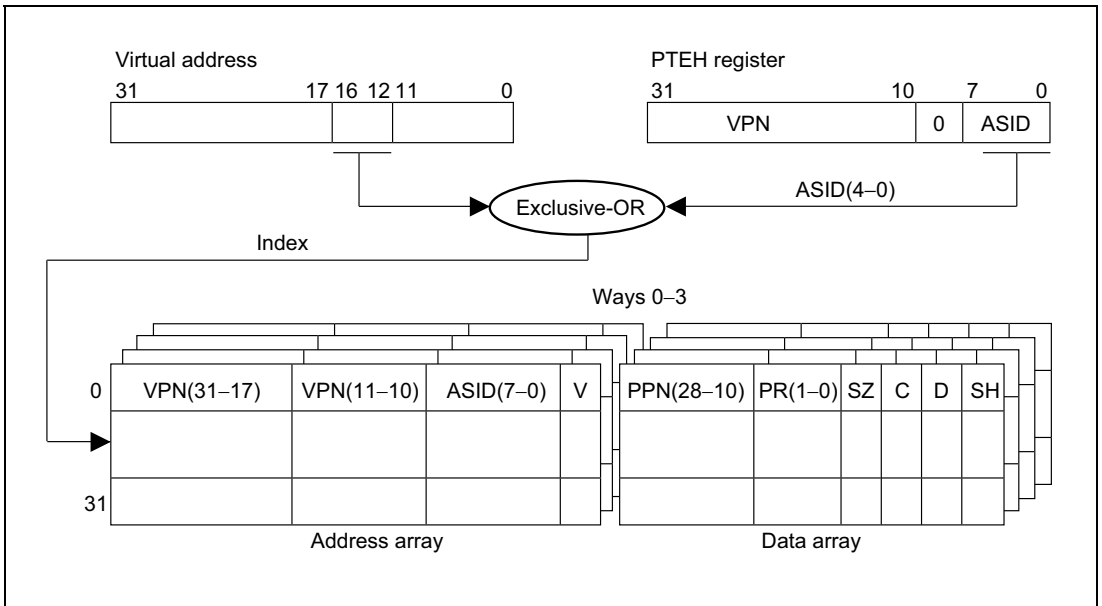

Figure 3.6 TLB Indexing (IX = 1)

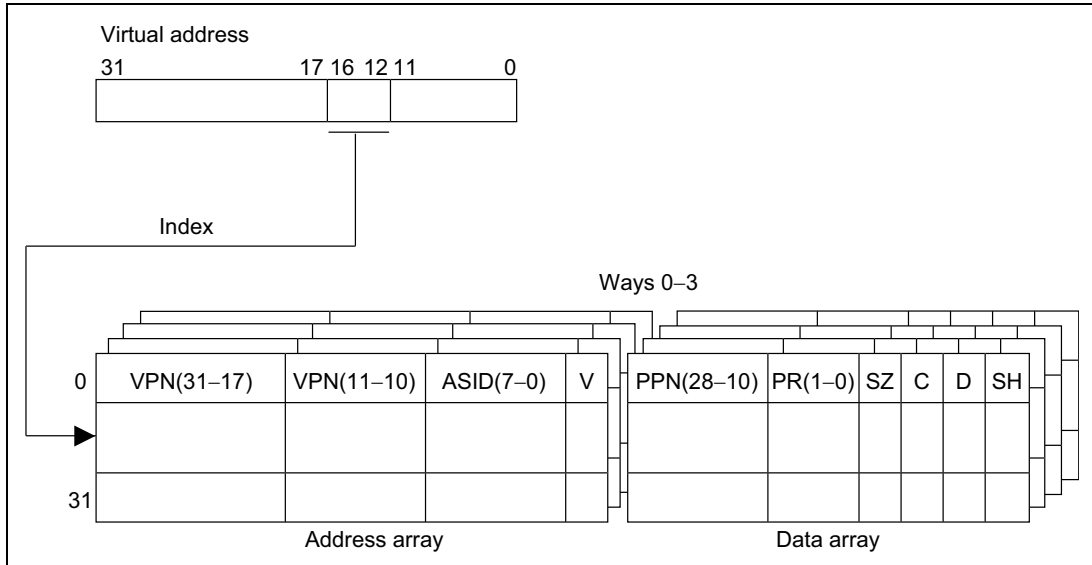

Figure 3.7 TLB Indexing (IX = 0)

3.3.3 TLB Address Comparison

The results of address comparison determine whether a specific virtual page number is registered in the TLB. The virtual page number of the virtual address that accesses external memory is compared to the virtual page number of the indexed TLB entry. The ASID within the PTEH is compared to the ASID of the indexed TLB entry. All four ways are searched simultaneously. If the compared values match, and the indexed TLB entry is valid (V bit = 1), the hit is registered.

It is necessary to have software ensure that TLB hits do not occur simultaneously in more than one way, as hardware operation is not guaranteed if this occurs. For example, if there are two identical TLB entries with the same VPN and a setting is made such that a TLB hit is made only by a process with ASID = H'FF when one is in the shared state (SH = 1) and the other in the non-shared state (SH = 0), then if the ASID in PTEH is set to H'FF, there is a possibility of simultaneous TLB hits in both these ways. It is therefore necessary to ensure that this kind of setting is not made by software.

The object compared varies depending on the page management information (SZ, SH) in the TLB entry. It also varies depending on whether the system supports multiple virtual memory or single virtual memory.

The page-size information determines whether VPN (11-10) is compared. VPN (11-10) is compared for 1-kbyte pages (SZ = 0) but not for 4-kbyte pages (SZ = 1).

The sharing information (SH) determines whether the PTEH.ASID and the ASID in the TLB entry are compared. ASIDs are compared when there is no sharing between processes (SH = 0) but not when there is sharing (SH = 1).

When single virtual memory is supported (MMUCR.SV = 1) and privileged mode is engaged (SR.MD = 1), all process resources can be accessed. This means that ASIDs are not compared when single virtual memory is supported and privileged mode is engaged. The objects of address comparison are shown in figure 3.8.

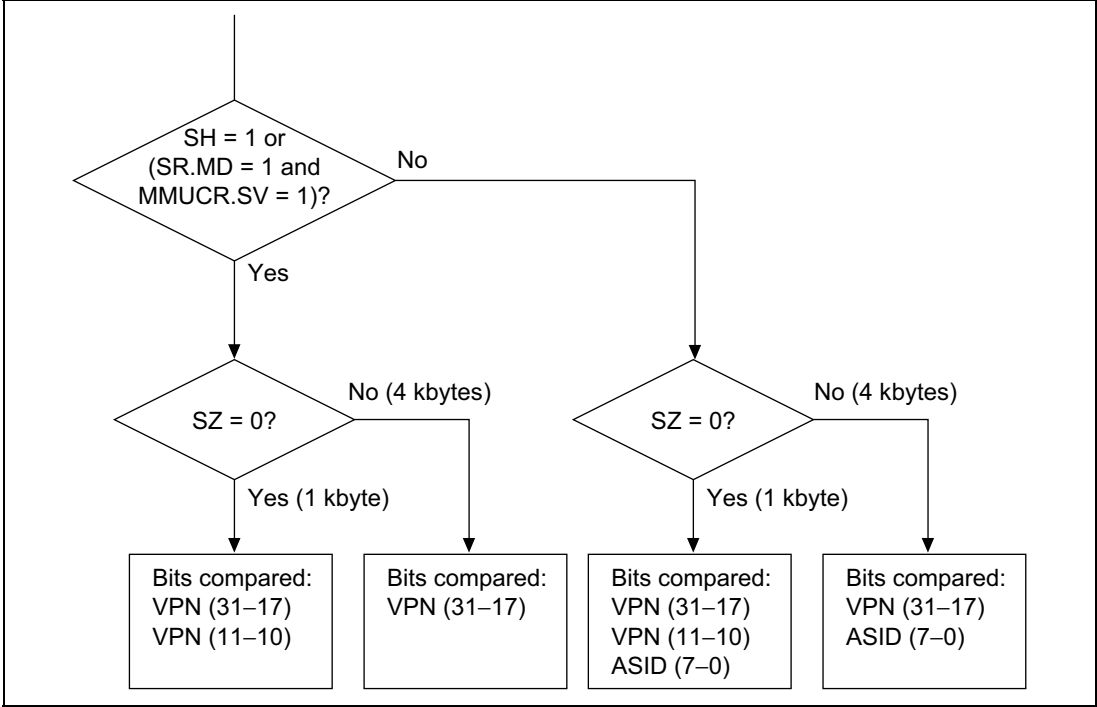

Figure 3.8 Objects of Address Comparison

3.3.4 Page Management Information

In addition to the SH and SZ bits, the page management information of TLB entries also includes D, C, and PR bits.

The D bit of a TLB entry indicates whether the page is dirty (i.e., has been written to). If the D bit is 0, an attempt to write to the page results in an initial page write exception. For physical page swapping between secondary memory and main memory, for example, pages are controlled so that a dirty page is paged out of main memory only after that page is written back to secondary memory.

The C bit in the entry indicates whether the referenced page resides in a cacheable or non-cacheable area of memory. When the control register in area 1 is mapped, set the C bit to 0. The PR field specifies the access rights for the page in privileged and user modes and is used to protect memory. Attempts at nonpermitted accesses result in TLB protection violation exceptions.

Access states designated by the D, C, and PR bits are shown in table 3.2.

Table 3.2 Access States Designated by D, C, and PR Bits

		Privileged Mode		User Mode	
		Reading	Writing	Reading	Writing
D bit	0	Permitted	Initial page write exception	Permitted	Initial page write exception
	1	Permitted	Permitted	Permitted	Permitted
C bit	0	Permitted (no caching)	Permitted (no caching)	Permitted (no caching)	Permitted (no caching)
	1	Permitted (with caching)	Permitted (with caching)	Permitted (with caching)	Permitted (with caching)
PR bit	00	Permitted	TLB protection violation exception	TLB protection violation exception	TLB protection violation exception
	01	Permitted	Permitted	TLB protection violation exception	TLB protection violation exception
	10	Permitted	TLB protection violation exception	Permitted	TLB protection violation exception
	11	Permitted	Permitted	Permitted	Permitted

3.4 MMU Functions

3.4.1 MMU Hardware Management

There are two kinds of MMU hardware management as follows:

1. The MMU decodes the virtual address accessed by a process and performs address translation by controlling the TLB in accordance with the MMUCR settings.
2. In address translation, the MMU receives page management information from the TLB, and determines the MMU exception and whether the cache is to be accessed (using the C bit). For details of the determination method and the hardware processing, see section 3.5, MMU Exceptions.

3.4.2 MMU Software Management

There are three kinds of MMU software management, as follows.

1. MMU register setting. MMUCR setting, in particular, should be performed in areas P1 and P2 for which address translation is not performed. Also, since SV and IX bit changes constitute address translation system changes, in this case, TLB flushing should be performed by simultaneously writing 1 to the TF bit also. Since MMU exceptions are not generated in the MMU disabled state with the AT bit cleared to 0, use in the disabled state must be avoided with software that does not use the MMU.
2. TLB entry recording, deletion, and reading. TLB entry recording can be done in two ways by using the LDTLB instruction, or by writing directly to the memory-mapped TLB. For TLB entry deletion and reading, the memory allocation TLB can be accessed. See section 3.4.3, MMU Instruction (LDTLB), for details of the LDTLB instruction, and section 3.6, Configuration of Memory-Mapped TLB, for details of the memory-mapped TLB.
3. MMU exception processing. When an MMU exception is generated, it is handled on the basis of information set from the hardware side. See section 3.5, MMU Exceptions, for details.

When single virtual memory mode is used, it is possible to create a state in which physical memory access is enabled in the privileged mode only by clearing the share status bit (SH) to 0 to specify recording of all TLB entries. This strengthens inter-process memory protection, and enables special access levels to be created in the privileged mode only.

Recording a 1-kbyte page TLB entry may result in a synonym problem. See section 3.4.4, Avoiding Synonym Problems.

3.4.3 MMU Instruction (LDTLB)

The load TLB instruction (LDTLB) is used to record TLB entries. When the IX bit in MMUCR is 0, the LDTLB instruction changes the TLB entry in the way specified by the RC bit in MMUCR to the value specified by PTEH and PTEL, using VPN bits 16–12 specified in PTEH as the index number. When the IX bit in MMUCR is 1, the EX-OR of VPN bits 16–12 specified in PTEH and ASID bits 4–0 in PTEH are used as the index number.

Figure 3.9 shows the case where the IX bit in MMUCR is 0.

When an MMU exception occurs, the virtual page number of the virtual address that caused the exception is set in PTEH by hardware. The way is set in the RC bit of MMUCR for each exception (see figure 3.3). Consequently, if the LDTLB instruction is issued after setting only PTEL in the MMU exception handling routine, TLB entry recording is possible. Any TLB entry can be updated by software rewriting of PTEH and the RC bits in MMUCR.

As the LDTLB instruction changes address translation information, there is a risk of destroying address translation information if this instruction is issued in the P0, U0, or P3 area. Make sure, therefore, that this instruction is issued in the P1 or P2 area. Also, an instruction associated with an access to the P0, U0, or P3 area (such as the RTE instruction) should be issued at least two instructions after the LDTLB instruction.

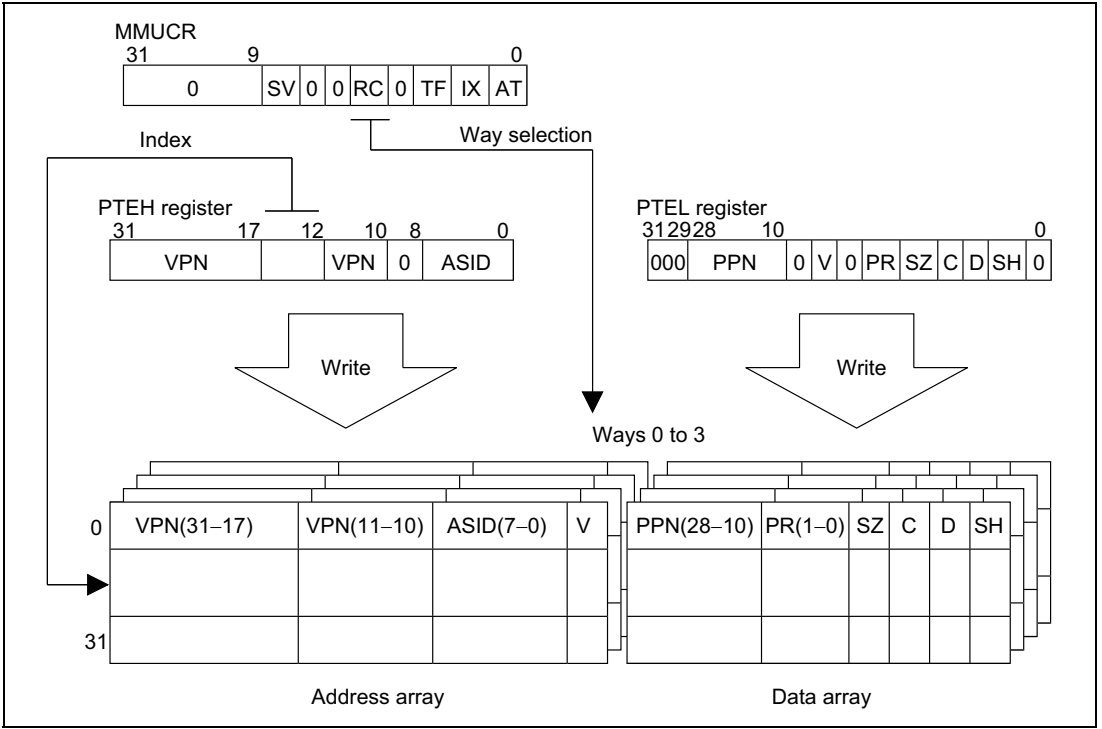

Figure 3.9 Operation of LDTLB Instruction

3.4.4 Avoiding Synonym Problems

When a 1-kbyte page is recorded in a TLB entry, a synonym problem may arise. If a number of virtual addresses are mapped onto a single physical address, the same physical address data will be recorded in a number of cache entries, and it will not be possible to guarantee data congruity. The reason why this problem only occurs when using a 1-kbyte page is explained below with reference to figure 3.10.

To achieve high-speed operation of the SH7709S cache, an index number is created using virtual address bits 11–4. When a 4-kbyte page is used, virtual address bits 11–4 are included in the offset, and since they are not subject to address translation, they are the same as physical address bits 11–4. In cache-based address comparison and recording in the address array, since the cache tag address is a physical address, physical address bits 28–10 are recorded.

When a 1-kbyte page is used, also, a cache index number is created using virtual address bits 11-4. However, in case of a 1-kbyte page, virtual address bit (11, 10) is subject to address translation and therefore may not be the same as physical address bit (11, 10). Consequently, the physical address is recorded in a different entry from that of the index number indicated by the physical address in the cache address array.

For example, assume that, with 1-kbyte page TLB entries, TLB entries for which the following translation has been performed are recorded in two TLBs:

Virtual address 1 H'00000000 → physical address H'00000400
Virtual address 2 H'00000400 → physical address H'00000400

Virtual address 1 is recorded in cache entry H'00, and virtual address 2 in cache entry H'C0. Since two virtual addresses are recorded in different cache entries despite the fact that the physical addresses are the same, memory inconsistency will occur as soon as a write is performed to either virtual address. Therefore, when recording a 1-kbyte TLB entry, if the physical address is the same as a physical address already used in another TLB entry, it should be recorded in such a way that physical address bit (11, 10) is the same.

Note: In readiness for the future expansion of the SuperH RISC engine family, we recommend that, when multiple sets of address translation information are mapped onto the same physical area of memory, you set the VPN numbers so that each VPN [20:10] is equal to the others. We also recommend that you do not map multiple sets of address-translation information that include 1- and 4-kbyte pages to a single physical area.

When using a 4-kbyte page

Virtual address

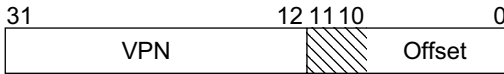

Physical address

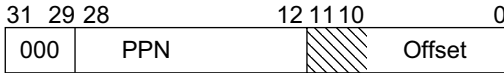

Virtual address (11-4)

Physical address (28-10)

Cache address array

When using a 1-kbyte page

Virtual address

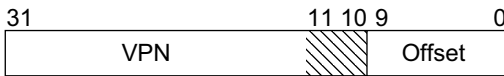

Physical address



Virtual address (11-4)

Physical address (28-10)

Cache address array

Figure 3.10 Synonym Problem

3.5 MMU Exceptions

There are four MMU exceptions: TLB miss, TLB protection violation, TLB invalid, and initial page write.

3.5.1 TLB Miss Exception

A TLB miss results when the virtual address and the address array of the selected TLB entry are compared and no match is found. TLB miss exception processing includes both hardware and software operations.

Hardware Operations: In a TLB miss, the SH7709S hardware executes a set of prescribed operations, as follows:

1. The VPN field of the virtual address causing the exception is written to the PTEH register.
2. The virtual address causing the exception is written to the TEA register.
3. Either exception code H'040 for a load access, or H'060 for a store access, is written to the EXPEVT register.
4. The PC value indicating the address of the instruction in which the exception occurred is written to the save program counter (SPC). If the exception occurred in a delay slot, the PC value indicating the address of the related delayed branch instruction is written to the SPC.
5. The contents of the status register (SR) at the time of the exception are written to the save status register (SSR).
6. The mode (MD) bit in SR is set to 1 to place the SH7709S in the privileged mode.
7. The block (BL) bit in SR is set to 1 to mask any further exception requests.
8. The register bank (RB) bit in SR is set to 1.
9. The random counter (RC) field in the MMU control register (MMUCR) is incremented by 1 when all ways are checked for the TLB entry corresponding to the logical address at which the exception occurred, and all ways are valid. If one or more ways are invalid, those ways are set in RC in prioritized order from way 0 through way 1, way 2, and way 3.
10. Execution branches to the address obtained by adding the value of the VBR contents and H'00000400 to invoke the user-written TLB miss exception handler.

Software (TLB Miss Handler) Operations: The software searches the page tables in external memory and allocates the required page table entry. Upon retrieving the required page table entry, software must execute the following operations:

1. Write the value of the physical page number (PPN) field and the protection key (PR), page size (SZ), cacheable (C), dirty (D), share status (SH), and valid (V) bits of the page table entry recorded in the address translation table in the external memory into the PTEL register in the SH7709S.

2. If using software for way selection for entry replacement, write the desired value to the RC field in MMUCR.
3. Issue the LDTLB instruction to load the contents of PTEH and PTEL into the TLB.
4. Issue the return from exception handler (RTE) instruction to terminate the handler routine and return to the instruction stream.

3.5.2 TLB Protection Violation Exception

A TLB protection violation exception results when the virtual address and the address array of the selected TLB entry are compared and a valid entry is found to match, but the type of access is not permitted by the access rights specified in the PR field. TLB protection violation exception processing includes both hardware and software operations.

Hardware Operations: In a TLB protection violation exception, the SH7709S hardware executes a set of prescribed operations, as follows:

1. The VPN field of the virtual address causing the exception is written to the PTEH register.
2. The virtual address causing the exception is written to the TEA register.
3. Either exception code H'0A0 for a load access, or H'0C0 for a store access, is written to the EXPEVT register.
4. The PC value indicating the address of the instruction in which the exception occurred is written into SPC (if the exception occurred in a delay slot, the PC value indicating the address of the related delayed branch instruction is written into SPC).
5. The contents of SR at the time of the exception are written to SSR.
6. The MD bit in SR is set to 1 to place the SH7709S in the privileged mode.
7. The BL bit in SR is set to 1 to mask any further exception requests.
8. The register bank (RB) bit in SR is set to 1.
9. The way that generated the exception is set in the RC field in MMUCR.
10. Execution branches to the address obtained by adding the value of the VBR contents and H'00000100 to invoke the TLB protection violation exception handler.

Software (TLB Protection Violation Handler) Operations: Software resolves the TLB protection violation and issues the RTE (return from exception handler) instruction to terminate the handler and return to the instruction stream.

3.5.3 TLB Invalid Exception

A TLB invalid exception results when the virtual address is compared to a selected TLB entry address array and a match is found but the entry is not valid (the V bit is 0). TLB invalid exception processing includes both hardware and software operations.

Hardware Operations: In a TLB invalid exception, the SH7709S hardware executes a set of prescribed operations, as follows:

1. The VPN number of the virtual address causing the exception is written to the PTEH register.
2. The virtual address causing the exception is written to the TEA register.
3. The way number causing the exception is written to RC in MMUCR.
4. Either exception code H'040 for a load access, or H'060 for a store access, is written to the EXPEVT register.
5. The PC value indicating the address of the instruction in which the exception occurred is written to the SPC. If the exception occurred in a delay slot, the PC value indicating the address of the delayed branch instruction is written to the SPC.
6. The contents of SR at the time of the exception are written into SSR.
7. The mode (MD) bit in SR is set to 1 to place the SH7709S in the privileged mode.
8. The block (BL) bit in SR is set to 1 to mask any further exception requests.
9. The register bank (RB) bit in SR is set to 1.
10. Execution branches to the address obtained by adding the value of the VBR contents and H'00000100, and the TLB protection violation exception handler starts.

Software (TLB Invalid Exception Handler) Operations: The software searches the page tables in external memory and assigns the required page table entry. Upon retrieving the required page table entry, software must execute the following operations:

1. Write the values of the physical page number (PPN) field and the values of the protection key (PR), page size (SZ), cacheable (C), dirty (D), share status (SH), and valid (V) bits of the page table entry recorded in the external memory to the PTEL register.
2. If using software for way selection for entry replacement, write the desired value to the RC field in MMUCR.
3. Issue the LDTLB instruction to load the contents of PTEH and PTEL into the TLB.
4. Issue the RTE instruction to terminate the handler and return to the instruction stream. The RTE instruction should be issued after two LDTLB instructions.

3.5.4 Initial Page Write Exception

An initial page write exception results in a write access when the virtual address and the address array of the selected TLB entry are compared and a valid entry with the appropriate access rights is found to match, but the D (dirty) bit of the entry is 0 (the page has not been written to). Initial page write exception processing includes both hardware and software operations.

Hardware Operations: In an initial page write exception, the SH7709S hardware executes a set of prescribed operations, as follows:

1. The VPN field of the virtual address causing the exception is written to the PTEH register.
2. The virtual address causing the exception is written to the TEA register.
3. Exception code H'080 is written to the EXPEVT register.
4. The PC value indicating the address of the instruction in which the exception occurred is written to the SPC. If the exception occurred in a delay slot, the PC value indicating the address of the related delayed branch instruction is written to the SPC.
5. The contents of SR at the time of the exception are written to SSR.
6. The MD bit in SR is set to 1 to place the SH7709S in the privileged mode.
7. The BL bit in SR is set to 1 to mask any further exception requests.
8. The register bank (RB) bit in SR is set to 1.
9. The way that caused the exception is set in the RC field in MMUCR.
10. Execution branches to the address obtained by adding the value of the VBR contents and H'00000100 to invoke the user-written initial page write exception handler.

Software (Initial Page Write Handler) Operations: The software must execute the following operations:

1. Retrieve the required page table entry from external memory.
2. Set the D bit of the page table entry in the external memory to 1.
3. Write the value of the PPN field and the PR, SZ, C, D, SH, and V bits of the page table entry in the external memory to the PTEL register.
4. If using software for way selection for entry replacement, write the desired value to the RC field in MMUCR.
5. Issue the LDTLB instruction to load the contents of PTEH and PTEL into the TLB.
6. Issue the RTE instruction to terminate the handler and return to the instruction stream. The RTE instruction should be issued after two LDTLB instructions.

Figure 3.11 shows the flowchart for MMU exceptions.

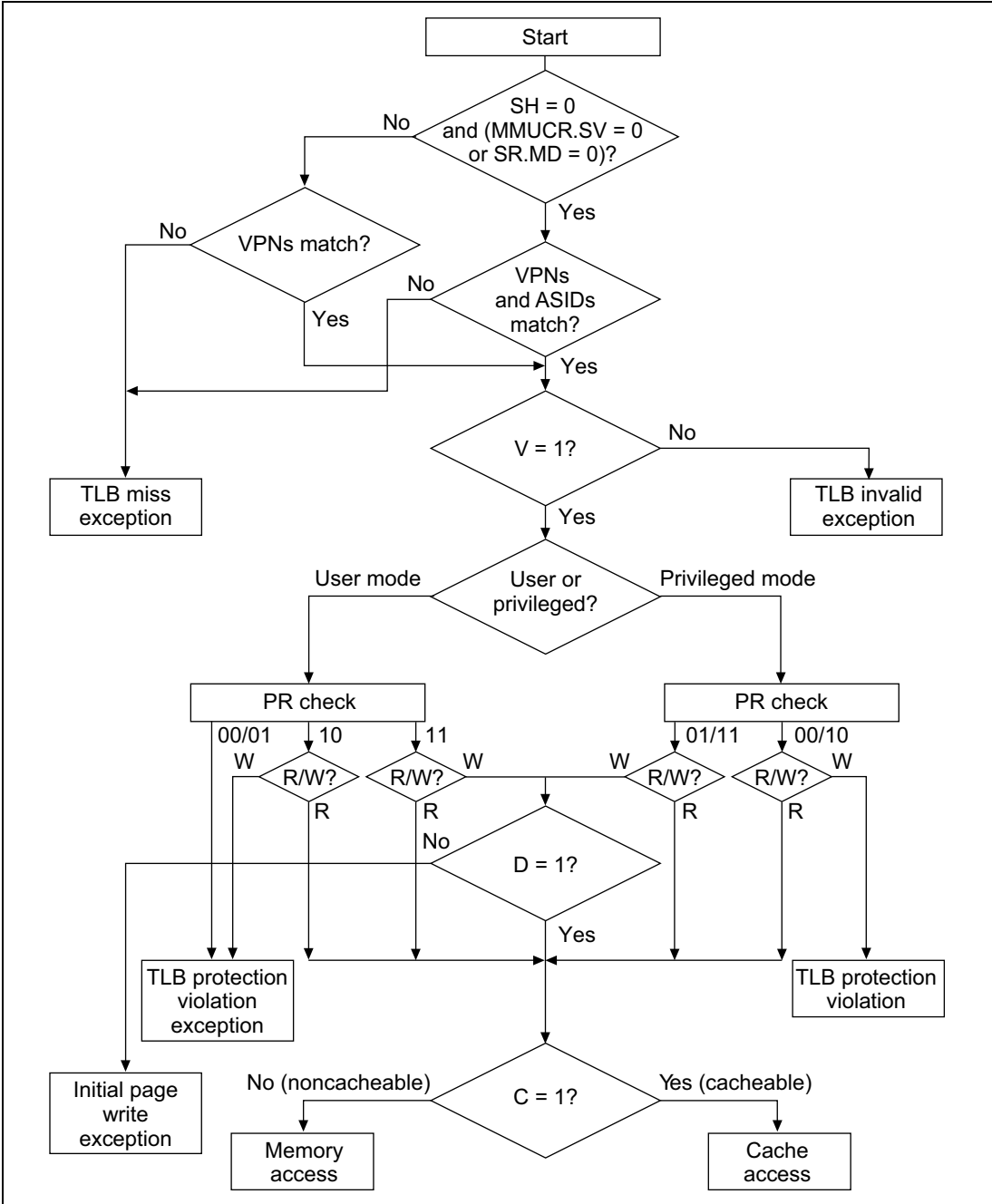

Figure 3.11 MMU Exception Generation Flowchart

3.5.5 Processing Flow in Event of MMU Exception (Same Processing Flow for Address Error)

Figure 3.12 shows the MMU exception signals in the instruction fetch mode.

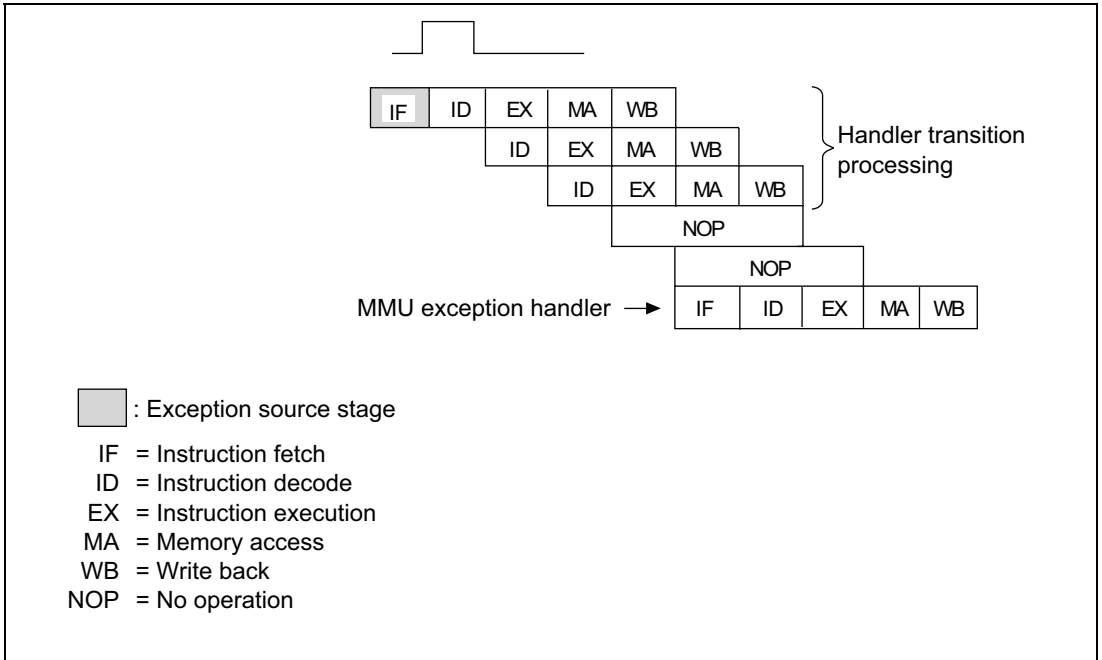

Figure 3.12 MMU Exception Signals in Instruction Fetch

Figure 3.13 shows the MMU exception signals in the data access mode.

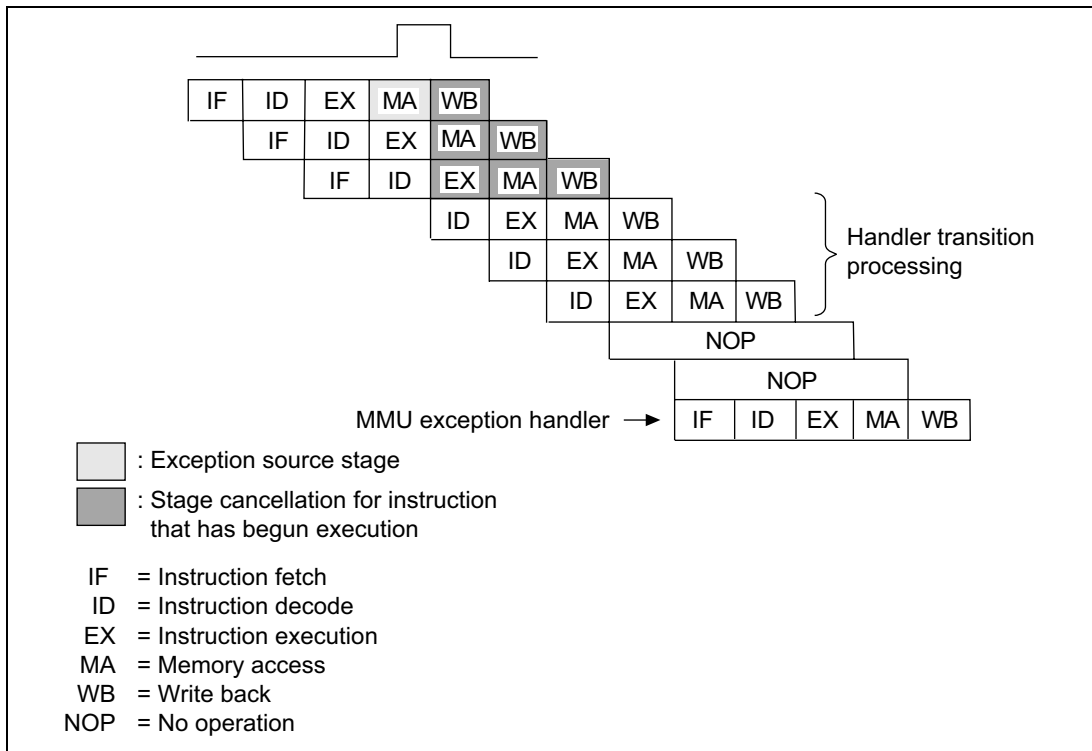

Figure 3.13 MMU Exception Signals in Data Access

3.6 Configuration of Memory-Mapped TLB

To allow the management of TLB operations by software, the MOV instruction can be used, in the privileged mode, to read and write TLB contents. The TLB is mapped to the P4 area of the virtual address space. The TLB address array (VPN, V bit, and ASID) is mapped to H'F2000000 to H'F2FFFFFFF, and the TLB data array (PPN, PR, SZ, CD, S, and H bits) is mapped to H'F3000000 to H'F3FFFFFFF. It is also possible to access the V bits in the address array from the data array. Only longword access is possible, for both the address and data arrays.

3.6.1 Address Array

The address array is mapped to H'F2000000 to H'F2FFFFFFF. To access the address array, the 32-bit address field (for read/write access) and 32-bit data field (for write access) must be specified. The address field has the information that selects the entry to be accessed; the data field specifies the VPN, the V bit, and the ASID to be written to the address array (figure 3.14 (1)).

In the address field, specify VPN in bits 16-12 as the index address that selects the entry, W in bits 9-8 to select the way, and H'F2 in bits 31-24 to indicate access to the address array. Selection of the index address depends on the MMUCR.IX setting.

The following 2 types of operations on the address array are possible.

(1) Address Array Read

Reads VPN, V bit, and ASID from the entry that corresponds to the entry address and way that were specified in the address field.

(2) Address Array Write

Writes the data set in the data field to the entry that corresponds to the entry address and way that were specified in the address field.

3.6.2 Data Array

The data array is assigned to H'F3000000 to H'F3FFFFFF. To access a data array, the 32-bit address field (for read/write operations), and 32-bit data field (for write operations) must be specified. These are specified in the general register. The address section specifies information for selecting the entry to be accessed; the data section specifies the longword data to be written to the data array (figure 3.14 (2)).

In the address section, specify the entry address for selecting the entry (bits 16–12), W for selecting the way (bits 9–8: 00 is way 0, 01 is way 1, 10 is way 2, 11 is way 3), and H'F3 to indicate data array access (bits 31–24). The IX bit in MMUCR indicates whether an EX-OR is taken of the entry address and ASID.

Both reading and writing use the longword of the data array specified by the index address and way number. The access size of the data array is fixed at longword.

(1) TLB Address Array Access

Read access

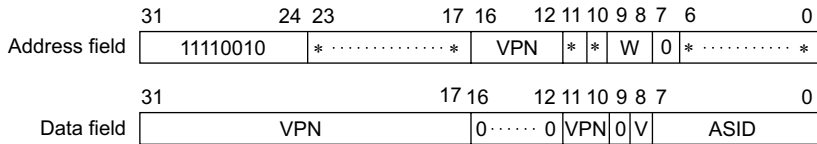

Write access

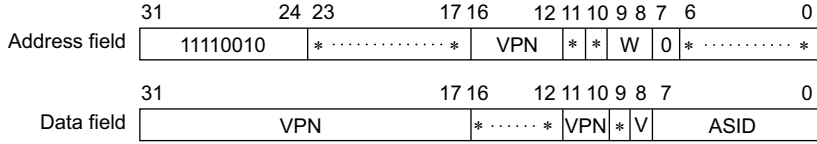

VPN: Virtual page number ASID: Address space identifier
 V: Valid bit *: Don't care bit
 W: Way (00: Way 0, 01: Way 1, 10: Way 2, 11: Way 3)

(2) TLB Data Array Access

Read/write access

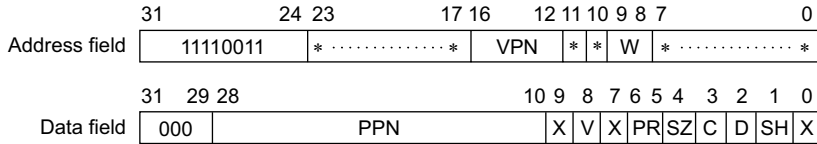

PPN: Physical page number V: Valid bit
 PR: Protection key field SZ: Page-size bit
 C: Cacheable bit D: Dirty bit
 SH: Share status bit *: Don't care bit
 VPN: Virtual page number
 X: 0 for read, don't care bit for write
 W: Way (00: Way 0, 01: Way 1, 10: Way 2, 11: Way 3)

Figure 3.14 Specifying Address and Data for Memory-Mapped TLB Access

3.6.3 Usage Examples

Invalidating Specific Entries: Specific TLB entries can be invalidated by writing 0 to the entry's V bit. When the A bit is 1, the VPN and ASID specified by the write data is compared to the VPN and ASID within the TLB entry selected by the entry address and data is written to the matching way. If no match is found, there is no operation. R0 specifies the write data and R1 specifies the address.

```
; R0=H'1547 381C R1=H'F201 3000
; MMUCR.IX=0
; VPN(31-17)=B'0001 0101 0100 011 VPN(11-10)=B'10 ASID=B'0001 1100
; corresponding entry association is made from the entry selected by
; the VPN(16-12)=B'1 0011 index, the V bit of the hit way is cleared to
; 0, achieving invalidation.
MOV.L R0,@R1
```

Reading the Data of a Specific Entry: This example reads the data section of a specific TLB entry. The bit order indicated in the data field in figure 3.14 (2) is read. R0 specifies the address and the data section of a selected entry is read to R1.

```
; R1=H'F300 4300 VPN(16-12)=B'00100 Way 3
MOV.L @R0,R1
```

3.7 Usage Note

The operations listed below must only be performed when the TLB is disabled or in the P1 or P2 area. Any subsequent operation that accesses the P0, P3, or U0 area must take place two or more instructions after any of the below operations.

1. Change SR.MD or SR.BL
2. Execute the LDTLB instruction
3. Write to the memory-mapped TLB
4. Change MMUCR.

Section 4 Exception Handling

4.1 Overview

4.1.1 Features

Exception handling is separate from normal program processing, and is performed by a routine separate from the normal program. In response to an exception handling request due to abnormal termination of the executing instruction, control is passed to a user-written exception handler. However, in response to an interrupt request, normal program execution continues until the end of the executing instruction. Here, all exceptions other than resets and interrupts will be called general exceptions. There are thus three types of exceptions: resets, general exceptions, and interrupts.

4.1.2 Register Configuration

Table 4.1 lists the registers used for exception handling. A register with an undefined initial value should be initialized by software.

Table 4.1 Register Configuration

Register	Abbr.	R/W	Size	Initial Value	Address
TRAPA exception register	TRA	R/W	Longword	Undefined	H'FFFFFFD0
Exception event register	EXPEVT	R/W	Longword	Power-on reset: H'000 Manual reset: H'020*1	H'FFFFFFD4
Interrupt event register	INTEVT	R/W	Longword	Undefined	H'FFFFFFD8
Interrupt event register2	INTEVT2	R	Longword	Undefined	H'04000000 (H'A4000000)*2

Notes: 1. H'000 is set in a power-on reset, and H'020 in a manual reset.

2. When address translation by the MMU does not apply, the address in parentheses should be used.

4.2 Exception Handling Function

4.2.1 Exception Handling Flow

In exception handling, the contents of the program counter (PC) and status register (SR) are saved in the saved program counter (SPC) and saved status register (SSR), respectively, and execution of the exception handler is invoked from a vector address. The return from exception handler (RTE) instruction is issued by the exception handler routine on completion of the routine, restoring the

contents of PC and SR to return to the processor state at the point of interruption and the address where the exception occurred.

A basic exception handling sequence consists of the following operations:

1. The contents of PC and SR are saved in SPC and SSR, respectively.
2. The block (BL) bit in SR is set to 1, masking any subsequent exceptions.
3. The mode (MD) bit in SR is set to 1 to place the SH7709S in privileged mode.
4. The register bank (RB) bit in SR is set to 1.
5. An exception code identifying the exception event is written to bits 11–0 of the exception event (EXPEVT) or interrupt event (INTEVT or INTEVT2) register.
6. Instruction execution jumps to the designated exception vector address to invoke the handler routine.

4.2.2 Exception Vector Addresses

The reset vector address is fixed at H'A0000000. The other three events are assigned offsets from the vector base address by software. Translation look-aside buffer (TLB) miss exceptions have an offset from the vector base address of H'00000400. The vector address offset for general exception events other than TLB miss exceptions is H'00000100. The interrupt vector address offset is H'00000600. The vector base address is loaded into the vector base register (VBR) by software. The vector base address should reside in P1 or P2 fixed physical address space. Figure 4.1 shows the relationship between the vector base address, the vector offset, and the vector table.

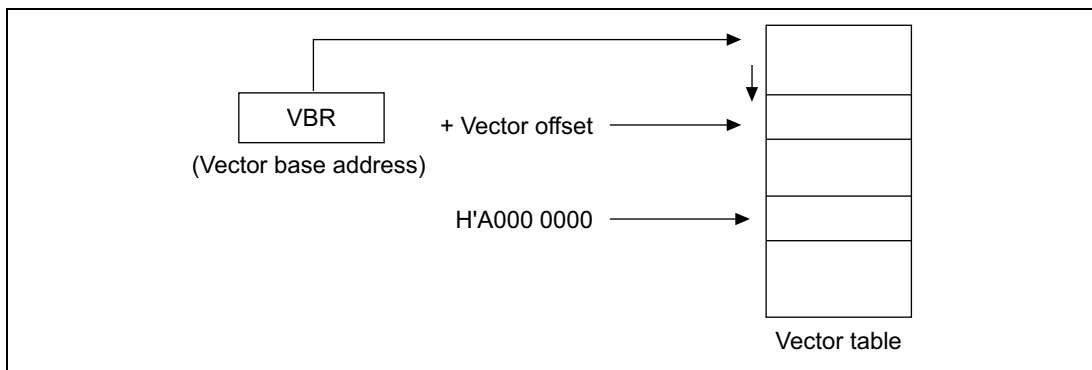

Figure 4.1 Vector Table

In table 4.2, exceptions and their vector addresses are listed by exception type, instruction completion state, relative acceptance priority, relative order of occurrence within an instruction execution sequence and vector address for exceptions and their vector addresses.

Table 4.2 Exception Event Vectors

Exception Type	Current Instruction	Exception Event	Priority* ¹	Exception Order	Vector Address	Vector Offset	
Reset	Aborted	Power-on reset	1	—	H'A00000000	—	
		Manual reset	1	—	H'A00000000	—	
		UDI reset	1	—	H'A00000000	—	
General exception events	Aborted and retried	CPU address error (instruction access)	2	1	—	H'00000100	
		TLB miss	2	2	—	H'00000400	
		TLB invalid (instruction access)	2	3	—	H'00000100	
		TLB protection violation (instruction access)	2	4	—	H'00000100	
		General illegal instruction exception	2	5	—	H'00000100	
		Illegal slot instruction exception	2	5	—	H'00000100	
		CPU address error (data access)	2	6	—	H'00000100	
		TLB miss (data access not in repeat loop)	2	7	—	H'00000400	
		TLB invalid (data access)	2	8	—	H'00000100	
		TLB protection violation (data access)	2	9	—	H'00000100	
		Initial page write	2	10	—	H'00000100	
		Completed	Unconditional trap (TRAPA instruction)	2	5	—	H'00000100
			User breakpoint trap	2	n* ²	—	H'00000100
DMA address error	2		—	—	H'00000100		
General interrupt requests	Completed	Nonmaskable interrupt	3	—	—	H'00000600	
		External hardware interrupt	4* ³	—	—	H'00000600	
		UDI interrupt	4* ³	—	—	H'00000600	

Notes: 1. Priorities are indicated from high to low, 1 being the highest and 4 the lowest.

2. The user defines the break point traps. 1 is a break point before instruction execution and 11 is a break point after instruction execution. For an operand break point, use 11.

3. Use software to specify relative priorities of external hardware interrupts and peripheral module interrupts (see section 6, Interrupt Controller (INTC)).

4.2.3 Acceptance of Exceptions

Processor resets and interrupts are asynchronous events unrelated to the instruction stream. All exception events are prioritized to establish an acceptance order whenever two or more exception events occur simultaneously.

All general exception events occur in a relative order in the execution sequence of an instruction (i.e. execution order), but are handled at priority level 2 in instruction-stream order (i.e. program order), where an exception detected in a preceding instruction is accepted prior to an exception detected in a subsequent instruction.

Three general exception events (reserved instruction code exception, unconditional trap, and slot illegal instruction exception) are detected in the decode stage (ID stage) of different instructions and are mutually exclusive events in the instruction pipeline. They have the same execution priority. Figure 4.2 shows the order of general exception acceptance.

Pipeline Sequence:

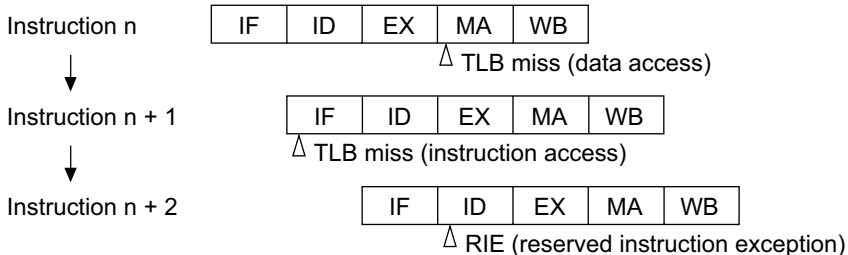

Detection Order:

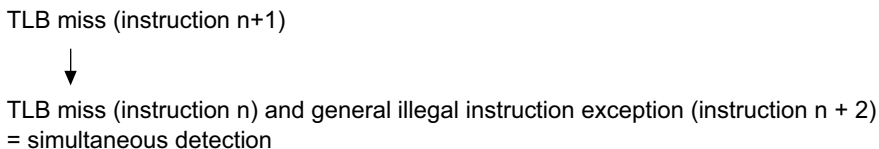

Handling Order:

Program Order:

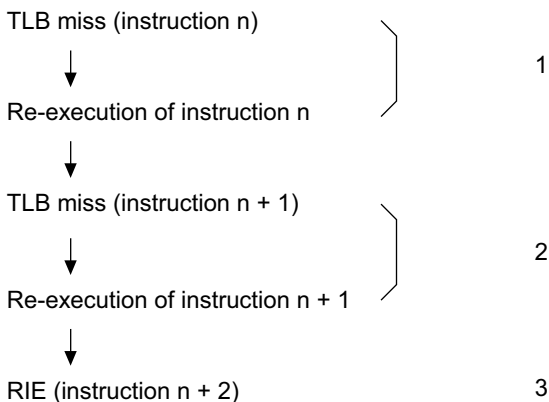

IF = Instruction fetch
ID = Instruction decode
EX = Instruction execution
MA = Memory access
WB = Write back

Figure 4.2 Example of Acceptance Order of General Exceptions

All exceptions other than a reset are detected in the pipeline ID stage, and accepted at instruction boundaries. However, an exception is not accepted between a delayed branch instruction and the delay slot. A re-execution type exception detected in a delay slot is accepted before execution of the delayed branch instruction. A completion type exception detected in a delayed branch

instruction or delay slot is accepted after execution of the delayed branch instruction. The delay slot here refers either to the next instruction after a delayed unconditional branch instruction or to the next instruction when a delayed conditional branch instruction is true.

4.2.4 Exception Codes

Table 4.3 lists the exception codes written to the EXPEVT register (for reset or general exceptions) or the INTEVT and INTEVT2 registers (for general interrupt requests) to identify each specific exception event.

Table 4.3 Exception Codes

Exception Type	Exception Event	Exception Code
Reset	Power-on reset	H'000
	Manual reset	H'020
	UDI reset	H'000
General exception events	TLB miss/invalid (read)	H'040
	TLB miss/invalid (write)	H'060
	Initial page write	H'080
	TLB protection violation (read)	H'0A0
	TLB protection violation (write)	H'0C0
	CPU address error (read)	H'0E0
	CPU address error (write)	H'100
	Unconditional trap (TRAPA instruction)	H'160
	Illegal general instruction exception	H'180
	Illegal slot instruction exception	H'1A0
	User breakpoint trap	H'1E0
	DMA address error	H'5C0
	General interrupt requests	Nonmaskable interrupt
UDI interrupt		H'5E0
External hardware interrupts:		
IRL3–IRL0 = 0000		H'200
IRL3–IRL0 = 0001	H'220	

Exception Type	Exception Event	Exception Code
General interrupt requests (cont)	External hardware interrupts (cont):	
	IRL3–IRL0 = 0010	H'240
	IRL3–IRL0 = 0011	H'260
	IRL3–IRL0 = 0100	H'280
	IRL3–IRL0 = 0101	H'2A0
	IRL3–IRL0 = 0110	H'2C0
	IRL3–IRL0 = 0111	H'2E0
	IRL3–IRL0 = 1000	H'300
	IRL3–IRL0 = 1001	H'320
	IRL3–IRL0 = 1010	H'340
	IRL3–IRL0 = 1011	H'360
	IRL3–IRL0 = 1100	H'380
	IRL3–IRL0 = 1101	H'3A0
	IRL3–IRL0 = 1110	H'3C0

4.2.5 Exception Request Masks

When the BL bit in SR is 0, exceptions and interrupts are accepted.

If a general exception event occurs when the BL bit in SR is 1, the CPU's internal registers are set to their post-reset state, other module registers retain their contents prior to the general exception, and a branch is made to the same address (H'A0000000) as for a reset.

If a general interrupt occurs when BL = 1, the request is masked (held pending) and not accepted until the BL bit is cleared to 0 by software. For reentrant exception handling, SPC and SSR must be saved and the BL bit in SR cleared to 0.

4.2.6 Returning from Exception Handling

The RTE instruction is used to return from exception handling. When RTE is executed, the SPC value is set in PC, and the SSR value in SR, and the return from exception handling is performed by branching to the SPC address.

If SPC and SSR have been saved in external memory, set the BL bit in SR to 1, then restore SPC and SSR, and issue an RTE instruction.

4.4 Exception Handling Operation

4.4.1 Reset

The reset sequence is used to power up or restart the SH7709S from the initialization state. The RESETP and RESETM signals are sampled every clock cycle, and in the case of a power-on reset, all processing being executed (excluding the RTC) is suspended, all unfinished events are canceled, and reset processing is executed immediately. In the case of a manual reset, however, reset processing is executed after completion of any memory access being executed. The reset sequence consists of the following operations:

1. The MD bit in SR is set to 1 to place the SH7709S in privileged mode.
2. The BL bit in SR is set to 1, masking any subsequent exceptions (except the NMI interrupt when the BLMSK bit is 1).
3. The RB bit in SR is set to 1.
4. An encoded value of H'000 in a power-on reset or H'020 in a manual reset is written to bits 11–0 of the EXPEVT register to identify the exception event.
5. Instruction execution jumps to the user-written exception handler at address H'A0000000.

4.4.2 Interrupts

An interrupt handling request is accepted on completion of the current instruction. The interrupt acceptance sequence consists of the following operations:

1. The contents of PC and SR are saved to SPC and SSR, respectively.
2. The BL bit in SR is set to 1, masking any subsequent exceptions (except the NMI interrupt when the BLMSK bit is 1).
3. The MD bit in SR is set to 1 to place the SH7709S in privileged mode.
4. The RB bit in SR is set to 1.
5. An encoded value identifying the exception event is written to bits 11–0 of the INTEVT and INTEVT2 registers.
6. Instruction execution jumps to the vector location designated by the sum of the value of the contents of the vector base register (VBR) and H'00000600 to invoke the exception handler.

4.4.3 General Exceptions

When the SH7709S encounters any exception condition other than a reset or interrupt request, it executes the following operations:

1. The contents of PC and SR are saved to SPC and SSR, respectively.
2. The BL bit in SR is set to 1, masking any subsequent exceptions (except the NMI interrupt when the BLMSK bit is 1).
3. The MD bit in SR is set to 1 to place the SH7709S in privileged mode.
4. The RB bit in SR is set to 1.
5. Instruction execution jumps to the vector location designated by either the sum of the vector base address and offset H'00000400 in the vector table in a TLB miss trap, or by the sum of the vector base address and offset H'00000100 for exceptions other than TLB miss traps, to invoke the exception handler.

4.5 Individual Exception Operations

This section describes the conditions for specific exception handling, and this LSI operations.

4.5.1 Resets

- Power-On Reset
 - Conditions: $\overline{\text{RESETP}}$ low
 - Operations: EXPEVT set to H'000, VBR and SR initialized, branch to PC = H'A0000000. Initialization sets the VBR register to H'00000000. In SR, the MD, RB and BL bits are set to 1 and the interrupt mask bits (I3 to I0) are set to B'1111. The CPU and on-chip peripheral modules are initialized. See the register descriptions in the relevant sections for details. A power-on reset must always be performed when powering on. A low level is output from the $\overline{\text{RESETOUT}}$ pin, and a high level is output from the STATUS0 and STATUS1 pins.
- Manual Reset
 - Conditions: $\overline{\text{RESETM}}$ low
 - Operations: EXPEVT set to H'020, VBR and SR initialized, branch to PC = H'A0000000. Initialization sets the VBR register to H'00000000. In SR, the MD, RB, and BL bits are set to 1 and the interrupt mask bits (I3 to I0) are set to B'1111. The CPU and on-chip peripheral modules are initialized. See the register descriptions in the relevant sections for details. A low level is output from the $\overline{\text{RESETOUT}}$ pin, and a high level is output from the STATUS0 and STATUS1 pins.

- UDI Reset
 - Conditions: UDI reset command input (see section 22.4.3, UDI Reset)
 - Operations: EXPEVT set to H'000, VBR and SR initialized, branch to PC = H'A0000000. Initialization sets the VBR register to H'00000000. In SR, the MD, RB and BL bits are set to 1 and the interrupt mask bits (I3 to I0) are set to B'1111. The CPU and on-chip peripheral modules are initialized. See the register descriptions in the relevant sections for details.

Table 4.4 Types of Reset

Type	Conditions for Transition to Reset State	Internal State	
		CPU	On-Chip Peripheral Modules
Power-on reset	$\overline{\text{RESETP}} = \text{Low}$	Initialized	(See register configuration in relevant sections)
Manual reset	$\overline{\text{RESETM}} = \text{Low}$	Initialized	
UDI reset	UDI reset command input	Initialized	

4.5.2 General Exceptions

- TLB miss exception
 - Conditions: Comparison of TLB addresses shows no address match.
 - Operations: The virtual address (32 bits) that caused the exception is set in TEA and the corresponding virtual page number (22 bits) is set in PTEH (31–10). The ASID of PTEH indicates the ASID at the time the exception occurred. If all ways are valid, 1 is added to the RC bit in MMUCR. If there is one or more invalid way, they are set by priority starting with way 0.

PC and SR of the instruction that generated the exception are saved to SPC and SSR, respectively. If the exception occurred during a read, H'040 is set in EXPEVT; if the exception occurred during a write, H'060 is set in EXPEVT. The BL, MD and RB bits in SR are set to 1 and a branch occurs to PC = VBR + H'0400.

To speed up TLB miss processing, the offset differs from other exceptions.

- TLB invalid exception

- Conditions: Comparison of TLB addresses shows address match but the TLB entry valid bit (V) is 0.
- Operations: The virtual address (32 bits) that caused the exception is set in TEA and the corresponding virtual page number (22 bits) is set in PTEH (31–10). The ASID of PTEH indicates the ASID at the time the exception occurred. The way that generated the exception is set in the RC bits in MMUCR.

PC and SR of the instruction that generated the exception are saved to SPC and SSR, respectively. If the exception occurred during a read, H'040 is set in EXPEVT; if the exception occurred during a write, H'060 is set in EXPEVT. The BL, MD, and RB bits in SR are set to 1 and a branch occurs to $PC = VBR + H'0100$.

- Initial page write exception

- Conditions: A hit occurred to the TLB for a store access, but the TLB entry data bit (D) is 0.
This occurs for initial writes to the page registered by the load.
- Operations: The virtual address (32 bits) that caused the exception is set in TEA and the corresponding virtual page number (22 bits) is set in PTEH (31–10). The ASID of PTEH indicates the ASID at the time the exception occurred. The way that generated the exception is set in the RC bit in MMUCR.

PC and SR of the instruction that generated the exception are saved to SPC and SSR, respectively. H'080 is set in EXPEVT. The BL, MD, and RB bits in SR are set to 1 and a branch occurs to $PC = VBR + H'0100$.

- TLB protection exception

- Conditions: When a hit access violates the TLB protection information (PR bits) shown below:

PR	Privileged mode	User mode
00	Only read enabled	No access
01	Read/write enabled	No access
10	Only read enabled	Only read enabled
11	Read/write enabled	Read/write enabled

- Operations: The virtual address (32 bits) that caused the exception is set in TEA and the corresponding virtual page number (22 bits) is set in PTEH (31–10). The ASID of PTEH indicates the ASID at the time the exception occurred. The way that generated the exception is set in the RC bits in MMUCR.

PC and SR of the instruction that generated the exception are saved to SPC and SSR, respectively. If the exception occurred during a read, H'0A0 is set in EXPEVT; if the exception occurred during a write, H'0C0 is set in EXPEVT. The BL, MD, and RB bits in SR are set to 1 and a branch occurs to $PC = VBR + H'0100$.

- CPU address error
 - Conditions:
 - a. Instruction fetch from odd address ($4n + 1$, $4n + 3$)
 - b. Word data accessed from addresses other than word boundaries ($4n + 1$, $4n + 3$)
 - c. Longword accessed from addresses other than longword boundaries ($4n + 1$, $4n + 2$, $4n + 3$)
 - d. Virtual space accessed in user mode in the area H'80000000 to H'FFFFFFF
 - Operations: The virtual address (32 bits) that caused the exception is set in TEA. PC and SR of the instruction that generated the exception are saved to SPC and SSR, respectively. If the exception occurred during a read, H'0E0 is set in EXPEVT; if the exception occurred during a write, H'100 is set in EXPEVT. The BL, MD, and RB bits in SR are set to 1 and a branch occurs to $PC = VBR + H'0100$. See section 3.5.5, Processing Flow in Event of MMU Exception, for more information.

- Unconditional trap
 - Conditions: TRAPA instruction executed
 - Operations: The exception is a processing-completion type, so PC of the instruction after the TRAPA instruction is saved to SPC. SR from the time when the TRAPA instruction was executing is saved to SSR. The 8-bit immediate value in the TRAPA instruction is quadrupled and set in TRA (9–0). H'160 is set in EXPEVT. The BL, MD, and RB bits in SR are set to 1 and a branch occurs to $PC = VBR + H'0100$.

- Illegal general instruction exception
 - Conditions:
 - a. When undefined code not in a delay slot is decoded
 - Delay branch instructions: JMP, JSR, BRA, BRAF, BSR, BSRF, RTS, RTE, BT/S, BF/S
 - Undefined instruction: H'Fxxx
 - b. When a privileged instruction not in a delay slot is decoded in user mode
 - Privileged instructions: LDC, STC, RTE, LDTLB, SLEEP; Instructions that access GBR with LDC/STC are not privileged instructions and therefore do not apply.
 - Operations: PC and SR of the instruction that generated this instruction are saved to SPC and SSR, respectively. H'180 is set in EXPEVT. The BL, MD, and RB bits in SR are set to 1 and a branch occurs to $PC = VBR + H'100$. When an undefined code other than H'Fxxx is decoded, operation cannot be guaranteed.

- Illegal slot instruction
 - Conditions:
 - a. When undefined code in a delay slot is decoded
Delay branch instructions: JMP, JSR, BRA, BRAF, BSR, BSRF, RTS, RTE, BT/S, BF/S
 - b. When an instruction that rewrites PC in a delay slot is decoded
Instructions that rewrite PC: JMP, JSR, BRA, BRAF, BSR, BSRF, RTS, RTE, BT, BF, BT/S, BF/S, TRAPA, LDC Rm, SR, LDC.L @Rm+, SR
 - c. When a privileged instruction in a delay slot is decoded in user mode
Privileged instructions: LDC, STC, RTE, LDTLB, SLEEP; Instructions that access GBR with LDC/STC are not privileged instructions and therefore do not apply.
 - Operations: PC of the immediately preceding delay branch instruction is saved to SPC. SR of the instruction that generated the exception is saved to SSR. H'1A0 is set in EXPEVT. The BL, MD, and RB bits in SR are set to 1 and a branch occurs to $PC = VBR + H'0100$. When an undefined instruction other than H'Fxxx is decoded, operation cannot be guaranteed.

- User break point trap
 - Conditions: When a break condition set in the user break controller is satisfied
 - Operations: When a post-execution break occurs, PC of the instruction immediately after the instruction that set the break point is set in SPC. If a pre-execution break occurs, PC of the instruction that set the break point is set in SPC. SR when the break occurs is set in SSR. H'1E0 is set in EXPEVT. The BL, MD, and RB bits in SR are set to 1 and a branch occurs to $PC = VBR + H'0100$. See section 7, User Break Controller, for more information.

- DMA address error
 - Conditions:
 - a. Word data accessed from addresses other than word boundaries ($4n + 1$, $4n + 3$)
 - b. Longword accessed from addresses other than longword boundaries ($4n + 1$, $4n + 2$, $4n + 3$)
 - Operations: PC of the instruction immediately after the instruction executed before the exception occurs is saved to SPC. SR when the exception occurs is saved to SSR. H'5C0 is set in EXPEVT. The BL, MD, and RB bits in SR are set to 1 and a branch occurs to $PC = VBR + H'0100$.

4.5.3 Interrupts

1. NMI

- Conditions: NMI pin edge detection
- Operations: PC after the instruction that receives the interrupt is saved to SPC, and SR at the point the interrupt is accepted is saved to SSR. H'01C0 is set to INTEVT and INTEVT2. The BL, MD, and RB bits of the SR are set to 1 and a branch occurs to PC = VBR + H'0600. This interrupt is not masked by SR.IMASK and is accepted with top priority when the BL bit in SR is 0. When the BL bit is 1, the interrupt is masked. See section 6, Interrupt Controller (INTC), for more information.

2. IRL Interrupts

- Conditions: The value of the interrupt mask bits in SR is lower than the IRL3–IRL0 level and the BL bit in SR is 0. The interrupt is accepted at an instruction boundary.
- Operations: The PC value after the instruction at which the interrupt is accepted is saved to SPC. SR at the time the interrupt is accepted is saved to SSR. The code corresponding to the IRL3–IRL0 level is set in INTEVT and INTEVT2. The corresponding code is given as $H'200 + [IRL3-IRL0] \times H'20$. See table 6.5, for the corresponding codes. The BL, MD, and RB bits in SR are set to 1 and a branch occurs to VBR + H'0600. The received level is not set in SR.IMASK. See section 6, Interrupt Controller (INTC), for more information.

3. IRQ Pin Interrupts

- Conditions: The IRQ pin is asserted, SR.IMASK is lower than the IRQ priority level, and the BL bit in SR is 0. The interrupt is accepted at an instruction boundary.
- Operations: The PC value after the instruction at which the interrupt is accepted is saved to SPC. SR at the point the interrupt is accepted is saved to SSR. The code corresponding to the interrupt source is set in INTEVT and INTEVT2. The BL, MD, and RB bits in SR are set to 1 and a branch occurs to VBR + H'0600. The received level is not set in the interrupt mask bits in SR. See section 6, Interrupt Controller (INTC), for more information.

4. PINT Pin Interrupts

- Conditions: The PINT pin is asserted, the interrupt mask bits in SR. is lower than the PINT priority level, and the BL bit in SR is 0. The interrupt is accepted at an instruction boundary.
- Operations: The PC value after the instruction at which the interrupt is accepted is saved to SPC. SR at the point the interrupt is accepted is saved to SSR. The code corresponding to the interrupt source is set in INTEVT and INTEVT2. The BL, MD, and RB bits of SR are set to 1 and a branch occurs to VBR + H'0600. The received level is not set in the interrupt mask bits in SR. See section 6, Interrupt Controller (INTC), for more information.

5. On-Chip Peripheral Interrupts

- Conditions: The interrupt mask bits in SR are lower than the on-chip module (TMU, RTC, SCI, IrDA, SCIF, A/D, DMAC, WDT, REF) interrupt level and the BL bit in SR is 0. The interrupt is accepted at an instruction boundary.
- Operations: The PC value after the instruction at which the interrupt is accepted is saved to SPC. SR at the point the interrupt is accepted is saved to SSR. The code corresponding to the interrupt source is set in INTEVT and INTEVT2. The BL, MD, and RB bits in SR are set to 1 and a branch occurs to VBR + H'0600. See section 6, Interrupt Controller (INTC), for more information.

6. UDI Interrupt

- Conditions: An UDI interrupt command is input (see section 22.4.4, UDI Interrupt), SR.IMASK is lower than 15, and the BL bit in SR is 0. The interrupt is accepted at an instruction boundary.
- Operations: The PC value after the instruction that accepts the interrupt is saved to SPC. SR at the point the interrupt is accepted is saved to SSR. H'5E0 is set to INTEVT and INTEVT2. The BL, MD, and RB bits in SR are set to 1 and a branch occurs to VBR + H'0600. See section 6, Interrupt Controller (INTC), for more information.

4.6 Cautions

- Return from exception handling
 - Check the BL bit in SR with software. When SPC and SSR have been saved to external memory, set the BL bit in SR to 1 before restoring them.
 - Issue an RTE instruction, which sets SPC in PC and SSR in SR, and causes a branch to the SPC address, and return from exception handling.
- Operation when exception or interrupt occurs while SR.BL = 1
 - Interrupt: Acceptance is suppressed until the BL bit in SR is cleared to 0. If there is an interrupt request and the reception conditions are satisfied, the interrupt is accepted after the execution of the instruction that clears the BL bit in SR to 0. In sleep or standby mode, however, the interrupt will be accepted even when the BL bit in SR is 1.
 - Exception: No user break point trap will occur even when the break conditions are met. When one of the other exceptions occurs, a branch is made to the fixed address of the reset (H'A0000000). In this case, the values of the EXPEVT, SPC, and SSR registers are undefined. Differently from general reset processing, the $\overline{\text{RESETOUT}}$ pin is not asserted, and reset status is output from the STATUS0 and STATUS1 pins.

- SPC when exception occurs: The PC saved to SPC when an exception occurs is as shown below:
 - Re-executing-type exceptions: PC of the instruction that caused the exception is set in SPC and re-executed after return from exception handling. If the exception occurred in a delay slot, however, PC of the immediately prior delayed branch instruction is set in SPC. If the condition of the conditional delayed branch instruction is not satisfied, the delay slot PC is set in SPC.
 - Completed-type exceptions and interrupts: PC of the instruction after the one that caused the exception is set in SPC. If the exception was caused by a conditional delayed branch instruction, however, the branch destination PC is set in SPC. If the condition of the conditional delayed branch instruction is not satisfied, the delay slot PC is set in SPC.
- Initial register values after reset
 - Undefined registers
R0_BANK0/1–R7_BANK0/1, R8–R15, GBR, SPC, SSR, MACH, MACL, PR
 - Initialized registers
VBR = H'00000000
SR.MD = 1, SR.BL = 1, SR.RB = 1, SR.I3–SR.I0 = H'F. Other SR bits are undefined.
PC = H'A0000000
- Ensure that an exception is not generated at an RTE instruction delay slot, as operation is not guaranteed in this case.
- When the BL bit in the SR register is set to 1, ensure that a TLB-related exception or address error does not occur at an LDC instruction that updates the SR register and the following instruction. This will be identified as the occurrence of multiple exceptions, and may initiate reset processing.

Section 5 Cache

5.1 Overview

5.1.1 Features

The cache specifications are listed in table 5.1.

Table 5.1 Cache Specifications

Parameter	Specification
Capacity	16 kbytes
Structure	Instruction/data mixed, 4-way set associative
Locking	Way 2 and way 3 are lockable
Line size	16 bytes
Number of entries	256 entries/way
Write system	P0, P1, P3, U0: Write-back/write-through selectable
Replacement method	Least-recently-used (LRU) algorithm

5.1.2 Cache Structure

The cache mixes data and instructions and uses a 4-way set associative system. It is composed of four ways (banks), each of which is divided into an address section and a data section. Each of the address and data sections is divided into 256 entries. The data section of the entry is called a line. Each line consists of 16 bytes (4 bytes \times 4). The data capacity per way is 4 kbytes (16 bytes \times 256 entries), with a total of 16 kbytes in the cache as a whole (4 ways). Figure 5.1 shows the cache structure.

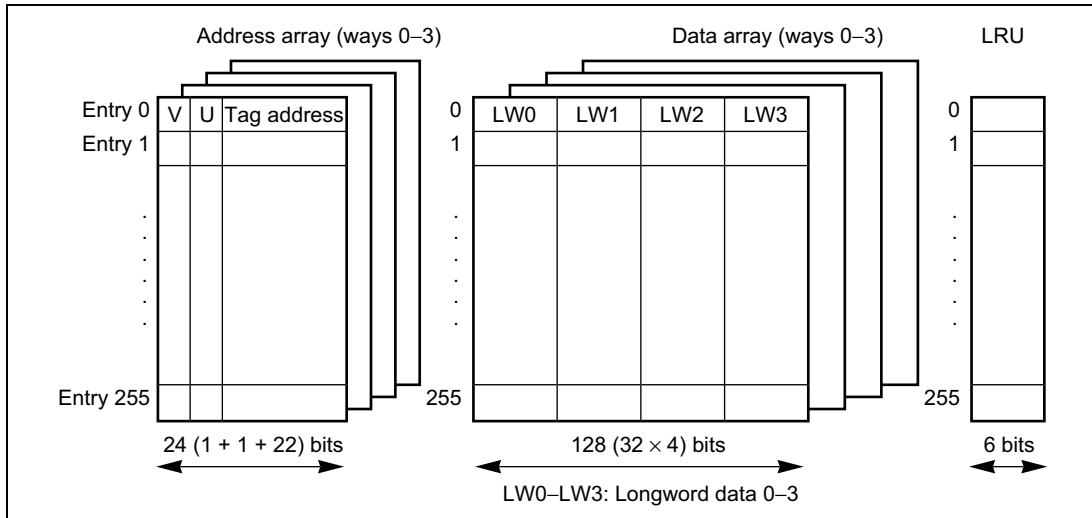

Figure 5.1 Cache Structure

Address Array: The V bit indicates whether the entry data is valid. When the V bit is 1, data is valid; when 0, data is not valid. The U bit indicates whether the entry has been written to in write-back mode. When the U bit is 1, the entry has been written to; when 0, it has not. The address tag holds the physical address used in the external memory access. It is composed of 22 bits (address bits 31–10) used for comparison during cache searches.

In the SH7709S, the top three of 32 physical address bits are used as shadow bits (see section 10, Bus State Controller (BSC)), and therefore in a normal replace operation the top three bits of the tag address are cleared to 0.

The V and U bits are initialized to 0 by a power-on reset, but are not initialized by a manual reset. The tag address is not initialized by either a power-on or manual reset.

Data Array: Holds a 16-byte instruction or data. Entries are registered in the cache in line units (16 bytes). The data array is not initialized by a power-on or manual reset.

LRU: With the 4-way set associative system, up to four instructions or data with the same entry address (address bits 11–4) can be registered in the cache. When an entry is registered, the LRU shows which of the four ways it is recorded in. There are six LRU bits, controlled by hardware. A least-recently-used (LRU) algorithm is used to select the way.

The way that is to be replaced on a cache miss is determined by the 6-bit LRU. Table 5.2 shows the correspondence between the LRU bits and the way to be replaced when the cache-lock function is not used (when the cache-lock function is used, refer to section 5.2.2, Cache Control Register 2 (CCR2)). If a bit pattern other than those listed in table 5.2 is set in the LRU bits by software, the cache will not function correctly. When modifying the LRU bits by software, set one of the patterns listed in table 5.2.

The LRU bits are initialized to 000000 by a power-on reset, but are not initialized by a manual reset.

Table 5.2 LRU and Way Replacement (When the cache lock function is not used)

LRU (5–0)	Way to be Replaced
000000, 000100, 010100, 100000, 110000, 110100	3
000001, 000011, 001011, 100001, 101001, 101011	2
000110, 000111, 001111, 010110, 011110, 011111	1
111000, 111001, 111011, 111100, 111110, 111111	0

5.1.3 Register Configuration

Table 5.3 shows details of the cache control register.

Table 5.3 Register Configuration

Register	Abbr.	R/W	Initial Value	Address	Access Size
Cache control register	CCR	R/W	H'00000000	H'FFFFFFEC	32-bit
Cache control register 2	CCR2	R/W	H'00000000	H'040000B0 (H'A40000B0)*	32-bit

Note: * When address translation by the MMU does not apply, the address in parentheses should be used.

5.2 Register Description

5.2.1 Cache Control Register (CCR)

The cache is enabled or disabled using the CE bit of the cache control register (CCR). CCR also has a CF bit (which invalidates all cache entries), and a WT and CB bits (which select either write-through mode or write-back mode). Programs that change the contents of the CCR register should be placed in address space that is not cached. When updating the contents of the CCR register, always set bits 4 to 0. Figure 5.2 shows the configuration of the CCR register.

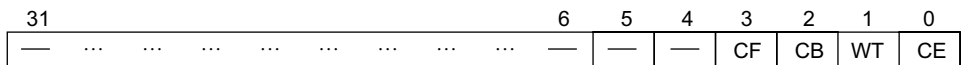

- : Reserved bits. Always 0 when reading. Data written here is also always 0.
- CF: Cache flush bit. Writing 1 flushes all cache entries (clears the V, U, and LRU bits of all cache entries to 0). Always reads 0. Write-back to external memory is not performed when the cache is flushed.
- CB: Write-back/write-through switchover bit. Indicates the cache's operating mode for area P1. 1 = write-back mode, 0 = write-through mode.
- WT: Write-through bit. Indicates the cache's operating mode for area P0, U0, and P3. 1 = write-through mode, 0 = write-back mode.
- CE: Cache enable bit. Indicates whether the cache function is used. 1 = cache used, 0 = cache not used.

Figure 5.2 CCR Register Configuration

5.2.2 Cache Control Register 2 (CCR2)

CCR2 is used to control the cache-lock function and is valid only in cache locking mode. Cache locking mode means that the cache lock bit (bit 12) in SR (status register) is set to 1. The cache-lock function is invalid in non-cache locking mode (the cache-lock bit is 0).

When a prefetch instruction (PREF) is executed in cache locking mode and a cache miss occurs, one line size of data pointed to by Rn is brought to cache according to the setting of bits 9 and 8 (W3LOAD and W3LOCK) and bits 1 and 0 (W2LOAD and W2LOCK) in CCR2. Table 5.4 shows the relationship between the bit setting and way to be replaced when a prefetch instruction is executed. When a prefetch instruction is executed and there is a cache hit, new data is not fetched and an entry which has already been valid is retained. For example, when the cache-lock, W3LOAD, and W3LOCK bits are set to 1 and a prefetch instruction is executed while one line size of data pointed to by Rn is already in way 0, a cache hit occurs and data is not fetched to way 3.

When cache is accessed by means of instructions except for a prefetch instruction in cache locking mode, a way that is replaced by the W3LOCK and W2LOCK bits is restricted. Table 5.5 shows the relationship between the bit setting of CCR2 and way to be replaced.

The program which modifies the contents of CCR2 must be placed in an address space which does not cache.

Figure 5.3 shows the configuration of CCR2.

CCR2 is a write-only register; if read, an undefined value will be returned.

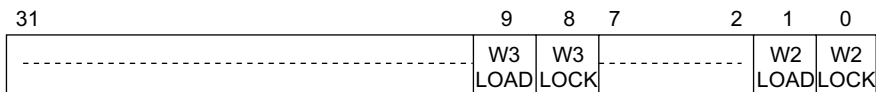

W2LOCK: Way 2 lock bit. W2LOAD: Way 2 load bit.

When W2LOCK = 1 & W2LOAD = 1 & SR, CL = 1, the prefetched data will always be loaded into Way2. In all other conditions the prefetched data will be loaded into the way pointed by LRU.

W3LOCK: Way 3 lock bit. W3LOAD: Way 3 load bit.

When W3LOCK = 1 & W3LOAD = 1 & SR, CL = 1, the prefetched data will always be loaded into Way3. In all other conditions the prefetched data will be loaded into the way pointed by LRU.

Note: W2LOAD and W3LOAD should not be set to high at the same time.

—: Reserved bits.

Figure 5.3 CCR2 Register Configuration

Whenever CCR2 bit 8 (W3LOCK) or bit 0 (W2LOCK) is high the cache is locked. The locked data will not be overwritten unless W3LOCK bit and W2LOCK bit are reset or the PREF condition during DSP mode matched. During cache locking mode, the LRU in table 5.2 will be replaced by tables 5.4 to 5.8.

Table 5.4 Way Replacement when PREF Instruction Ended Up in a Cache Miss

DSP bit	W3LOAD	W3LOCK	W2LOAD	W2LOCK	Way to be replaced
0	*	*	*	*	Depends on LRU (table 5.2)
1	*	0	*	0	Depends on LRU (table 5.2)
1	*	0	0	1	Depends on LRU (table 5.6)
1	0	1	*	0	Depends on LRU (table 5.7)
1	0	1	0	1	Depends on LRU (table 5.8)
1	0	*	1	1	Way 2
1	1	1	0	*	Way 3

*: Don't care

Do not set as W3LOAD=1 and also W2LOAD=1

Table 5.5 Way Replacement when Instructions Except for PREF Instruction Ended Up in a Cache Miss

DSP bit	W3LOAD	W3LOCK	W2LOAD	W2LOCK	Way to be replaced
0	*	*	*	*	Depends on LRU (table 5.2)
1	*	0	*	0	Depends on LRU (table 5.2)
1	*	0	*	1	Depends on LRU (table 5.6)
1	*	1	*	0	Depends on LRU (table 5.7)
1	*	1	*	1	Depends on LRU (table 5.8)

*: Don't care

Do not set as W3LOAD=1 and also W2LOAD=1

Table 5.6 LRU and Way Replacement (when W2LOCK=1)

LRU (5-0)	Way to be Replaced
000000, 000001, 000100, 010100, 100000, 100001, 110000, 110100	3
000011, 000110, 000111, 001011, 001111, 010110, 011110, 011111	1
101001, 101011, 111000, 111001, 111011, 111100, 111110, 111111	0

Table 5.7 LRU and Way Replacement (when W3LOCK=1)

LRU (5-0)	Way to be Replaced
000000, 000001, 000011, 001011, 100000, 100001, 101001, 101011	2
000100, 000110, 000111, 001111, 010100, 010110, 011110, 011111	1
110000, 110100, 111000, 111001, 111011, 111100, 111110, 111111	0

Table 5.8 LRU and Way Replacement (when W2LOCK=1 and W3LOCK=1)

LRU (5-0)	Way to be Replaced
000000, 000001, 000011, 000100, 000110, 000111, 001011, 001111, 010100, 010110, 011110, 011111	1
100000, 100001, 101001, 101011, 110000, 110100, 111000, 111001, 111011, 111100, 111110, 111111	0

5.3 Cache Operation

5.3.1 Searching the Cache

If the cache is enabled, whenever instructions or data in memory are accessed the cache will be searched to see if the desired instruction or data is in the cache. Figure 5.4 illustrates the method by which the cache is searched. The cache is a physical cache and holds physical addresses in its address section.

Entries are selected using bits 11–4 of the address (virtual) of the access to memory and the address tag of that entry is read. In parallel to reading of the address tag, the virtual address is translated to a physical address in the MMU. The physical address after translation and the physical address read from the address section are compared. The address comparison uses all four ways. When the comparison shows a match and the selected entry is valid ($V = 1$), a cache hit occurs. When the comparison does not show a match or the selected entry is not valid ($V = 0$), a cache miss occurs. Figure 5.4 shows a hit on way 1.

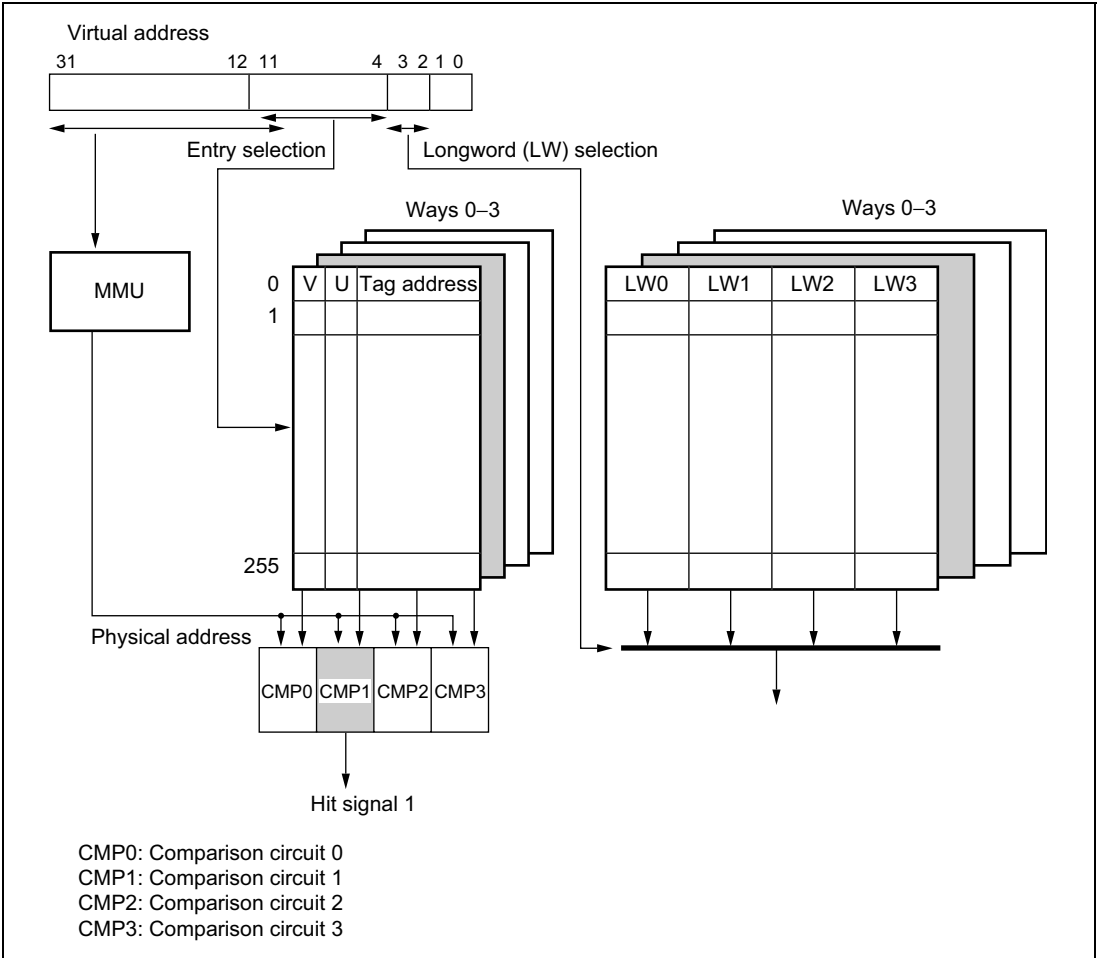

Figure 5.4 Cache Search Scheme (Normal Mode)

5.3.2 Read Access

Read Hit: In a read access, instructions and data are transferred from the cache to the CPU. The transfer unit is 32 bits. The LRU is updated.

Read Miss: An external bus cycle starts and the entry is updated. The way replaced is the one least recently used. Entries are updated in 16-byte units. When the desired instruction or data that caused the miss is loaded from external memory to the cache, the instruction or data is transferred to the CPU in parallel with being loaded to the cache. When it is loaded in the cache, the U bit is cleared to 0 and the V bit is set to 1.

5.3.3 Prefetch Operation

Prefetch Hit: The LRU will be updated to correctly indicate the latest way to have been hit. Other contents of the cache will remain unchanged. Neither instructions nor data are transferred to the CPU.

Prefetch Miss: Neither instructions nor data are transferred to the CPU, and way replacement takes place as shown in table 5.4. All other action is the same as for a read miss.

5.3.4 Write Access

Write Hit: In a write access in the write-back mode, the data is written to the cache and the U bit of the entry written is set to 1. Writing occurs only to the cache; no external memory write cycle is issued. In the write-through mode, the data is written to the cache and an external memory write cycle is issued.

Write Miss: In the write-back mode, an external write cycle starts when a write miss occurs, and the entry is updated. The way to be replaced is shown in table 5.5. When the U bit of the entry to be replaced is 1, the cache fill cycle starts after the entry is transferred to the write-back buffer. The write-back unit is 16 bytes. Data is written to the cache and the U bit is set to 1. After the cache completes its fill cycle, the write-back buffer writes back the entry to the memory. In the write-through mode, no write to cache occurs in a write miss; the write is only to the external memory.

5.3.5 Write-Back Buffer

When the U bit of the entry to be replaced in the write-back mode is 1, it must be written back to the external memory. To increase performance, the entry to be replaced is first transferred to the write-back buffer and fetching of new entries to the cache takes priority over writing back to the external memory. During the write back cycles, the cache can be accessed. The write-back buffer can hold one line of the cache data (16 bytes) and its physical address. Figure 5.5 shows the configuration of the write-back buffer.

PA (31–4)	Longword 0	Longword 1	Longword 2	Longword 3
-----------	------------	------------	------------	------------

PA (31–4): Physical address written to external memory
 Longword 0–3: The line of cache data to be written to external memory

Figure 5.5 Write-Back Buffer Configuration

5.3.6 Coherency of Cache and External Memory

Use software to ensure coherency between the cache and the external memory. When memory shared by this LSI and another device is placed in an address space to be cached, the memory allocation cache is manipulated if necessary and a write back should be performed by invalidating the entry. This is also applied to memory shared by the CPU and DMAC in this LSI.

5.4 Memory-Mapped Cache

To allow software management of the cache, cache contents can be read and written by means of MOV instructions in the privileged mode. The cache is mapped onto the P4 area in virtual address space. The address array is mapped onto addresses H'F0000000 to H'FOFFFFFFF, and the data array onto addresses H'F1000000 to H'F1FFFFFFF. Only longword can be used as the access size for the address array and data array, and instruction fetches cannot be performed.

5.4.1 Address Array

The address array is mapped to H'F0000000 to H'FOFFFFFFF. The 32-bit address field (for read/write accessed) and 32-bit data field (for write access) must be specified to access an element of the address array. The address field specifies information that selects the entry to be accessed; the data field specifies the tag address, V bit, U bit, and LRU bits to be written to the address array (figure 5.6 (1)).

In the address field, specify the entry's address in bits 11-4 to select the entry, W in bits 13-12 to select the way, the A bit (bit 3) to specify an associative operation, and H'F0 in bits 31-24 to indicate access to the address array. Settings for the W bits (13-12) are as follows: 00 is way 0, 01 is way 1, 10 is way 2, and 11 is way 3.

In the data field, specify the tag address in bits 31-10, LRU in bits 9-4, U bit in bit 1, and V bit in bit 0. The upper 3 bits (bit 31-29) of the tag address must always be 0.

The following three operations on the address array are possible.

(1) Address Array Read

Reads the tag address, LRU, U bit, and V bit from the entry that corresponds to the entry address and way that were specified in the address field. No associative operation will be performed, regardless of the value of the associative bit (the A bit).

(2) Address Array Write (without Associative Operation)

Writes the tag address, LRU, U bit, and V bit specified in the data field to the entry that corresponds to the entry address and way that were specified in the address field. The associative bit (A bit) of the address field must be set to 0. An attempt to write to a cache line for which both the U bit and V bit are set results in a write-back for that cache line. The tag address, LRU, U bit, and V bit specified in the data field are then written. Note that, when a 0 is written to the V bit, a 0 should always be written to the U bit of the same entry, too.

(3) Address Array Write (with Associative Operation)

The associative bit (A bit) in the address field indicates whether the addresses are compared during writing. With the A bit set to 1, all 4 ways for the entry specified in the address field will be compared to the tag address specified in the data field for a match. The values of the U bit and V bit specified in the data field will be written to the way that has a hit. However, the tag address and the LRU will not be changed. If no way receives a hit, writing does not take place and the result is no operation.

This operation is used to invalidate the address specification for a cache. Write back will take place when the U bit of the entry that received a hit is 1. Note that, when a 0 is written to the V bit, a 0 should always be written to the U bit of the same entry, too.

5.4.2 Data Array

The address array is mapped to H'F1000000 to H'F1FFFFFF. To access an element of the data array, the 32-bit address field (for read/write access) and 32-bit data field (for write access) must be specified. The address field specifies the information that selects the entry to be accessed; the data field specifies the longword data to be written to the data array.

In the address field, specify the entry's address in bits 11-4, L in bits 3-2 to indicate the longword's position within a line (which consists of 16 bytes), W in bits 13-12 to select the way, and H'F1 in bits 31-24 to indicate access to the data array. The L bits (3-2) specification is in the following form: 00 is longword 0, 01 is longword 1, 10 is longword 2, and 11 is longword 3. Settings for the W bits (13-12) are as follows: 00 is way 0, 01 is way 1, 10 is way 2, and 11 is way 3. Since access is not allowed crossing longword boundaries, always set 00 in bits 1-0 of the address field.

The following two operations on the data array are possible. Note that these operations will not change the information in the address array.

(1) Data Array Read

Reads the data at the position selected by the L bits (3-2) of the address field from the entry that corresponds to the entry address and way that were specified in the address field.

(2) Data Array Write

Writes the longword data set in the data field into the entry that corresponds to the entry address and way that were specified in the address field. The longword data will be written to the entry at the position selected by the L bits (3-2) of the address field.

1. Address array access

Address specification

Read access

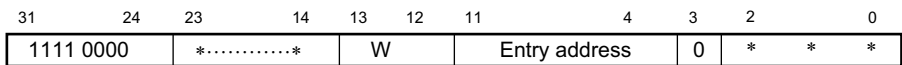

Write access

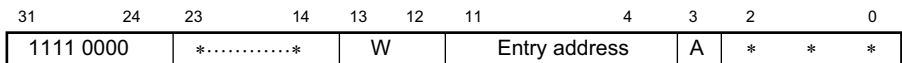

Data specification (both read and write accesses)

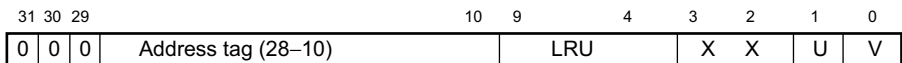

2. Data array access (both read and write accesses)

Address specification

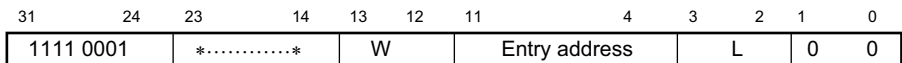

Data specification

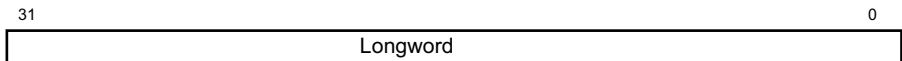

X: 0 for read, don't care for write

*: Don't care bit

Figure 5.6 Specifying Address and Data for Memory-Mapped Cache Access

5.4.3 Examples of Usage

(1) Invalidating a Specific Entry

A specific cache entry can be invalidated by accessing the allocated memory cache and writing a 0 to the entry's U and V bits. The A bit is cleared to 0, and an address is specified for the entry address and the way. If the U bit of the way of the entry in question was set to 1, the entry is written back and the V and U bits specified by the write data are written to.

In the following example, the write data is specified in R0 and the address is specified in R1.

```
; R0 = H'0000 0000 LRU = H'000, U = 0, V = 0
; R1 = H'F000 1080, Way = 1, Entry = H'08, A = 0
;
MOV.L R0, @R1
```

To invalidate all entries and ways, write 0 to the following addresses.

Addresses

```
F000 0000
F000 0010
F000 0020
:
F000 3FF0
```

This involves a total of 1,024 writes.

The above operation should be performed using a non-cacheable area.

(2) Invalidating a Specific Address

A specific address can be invalidated by writing a 0 to the entry's U and V bits. When the A bit is 1, the tag address specified by the write data is compared to the tag address within the cache selected by the entry address. If the tag addresses match, data is written to the memory at that address. If no match is found, no operation is carried out. If the entry's U bit is 1 at that time, the entry is written back.

```
; R0 = H'0110 0010; Tag address = B'0000 0001 0001 0000 0000 00, U = 0,
V = 0
; R1 = H'F000 0088; Address array access, Entry = H'08, A = 1
;
MOV.L R0, @R1
```

In the following example, an address (32-bit) to be purged is specified in R0.

```
MOV.L #H'0000FF0, R1 ;
AND   R0, R1         ; The entry address is fetched.
MOV.L #H'F0000008, R2 ;
OR    R1, R2         ; The start is set to H'F0 and the A bit
                    ; to 1.
MOV.L #H'1FFFC00, R3 ;
AND   R0, R3         ; The tag address is fetched. U = V = 0.
MOV.L R3, @R2        ; Associative purge.
```

The above operation should be performed using a non-cacheable area.

(3) Reading Data from a Specific Entry

This example reads the data section of a specific entry. The longword in the data field of the data array in figure 5.6 is read to the register.

```
; R0 = H'F100 004C; Data array access, Entry = H'04,
; Way = 0, Longword address = 3
;
MOV.L R0, @R1        ; Longword 3 is read.
```

Section 6 Interrupt Controller (INTC)

6.1 Overview

The interrupt controller (INTC) ascertains the priority of interrupt sources and controls interrupt requests to the CPU. The INTC registers set the order of priority of each interrupt, allowing the user to process interrupt requests according to the user-set priority.

6.1.1 Features

The INTC has the following features:

- 16 levels of interrupt priority can be set: By setting the five interrupt-priority registers, the priorities of on-chip peripheral module, IRQ, and PINT interrupts can be selected from 16 levels for individual request sources.
- NMI noise canceler function: An NMI input-level bit indicates the NMI pin state. By reading this bit in the interrupt exception service routine, the pin state can be checked, enabling it to be used as a noise canceler.
- External devices can be notified that an interrupt has been received ($\overline{\text{IRQOUT}}$): When the SH7709S has released the bus, the external bus master can be notified that an external interrupt, an on-chip peripheral module interrupt, or a memory refresh request has occurred, enabling the bus to be requested.

6.1.2 Block Diagram

Figure 6.1 shows a block diagram of the INTC.

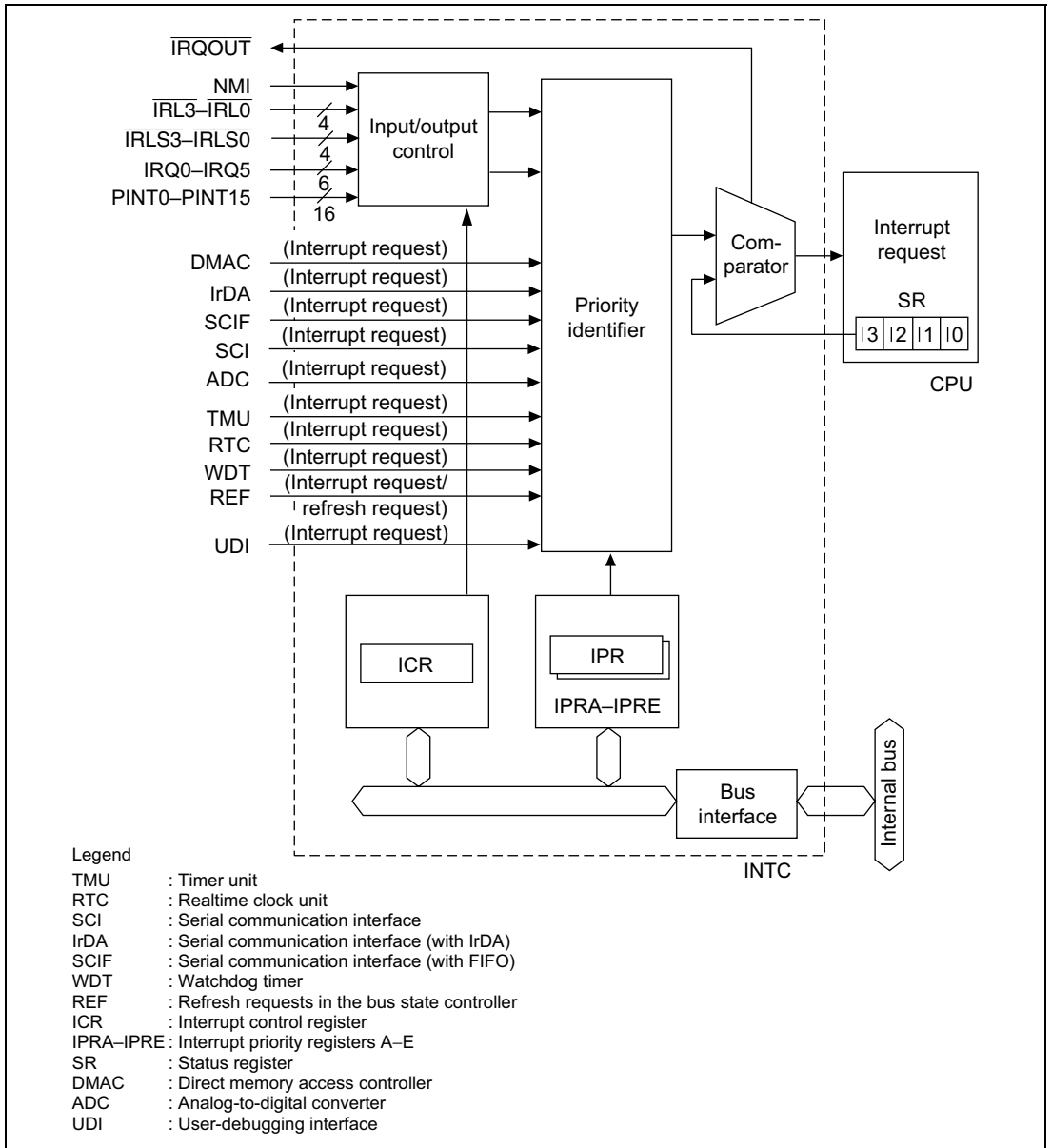

Figure 6.1 Block Diagram of INTC

6.1.3 Pin Configuration

Table 6.1 shows the INTC pin configuration.

Table 6.1 INTC Pins

Name	Abbreviation	I/O	Description
Nonmaskable interrupt input pin	NMI	I	Input of interrupt request signal, not maskable by the interrupt mask bits in SR.
Interrupt input pins	$\overline{\text{IRQ5}}\text{--}\overline{\text{IRQ0}}$ $\overline{\text{IRL3}}\text{--}\overline{\text{IRL0}}$ $\overline{\text{IRLS3}}\text{--}\overline{\text{IRLS0}}$	I	Input of interrupt request signals, maskable by the interrupt mask bits in SR.
Port interrupt input pins	PINT0–PINT15	I	Input of port interrupt request signals, maskable by the interrupt mask bits in SR.
Bus request output pin	$\overline{\text{IRQOUT}}$	O	Output of signal that notifies external devices that an interrupt source or memory refresh has occurred

6.1.4 Register Configuration

The INTC has the 12 registers listed in table 6.2.

Table 6.2 INTC Registers

Name	Abbr.	R/W	Initial Value* ¹	Address	Access Size
Interrupt control register 0	ICR0	R/W	* ²	H'FFFFFFE0	16
Interrupt control register 1	ICR1	R/W	H'0000	H'04000010 (H'A4000010)* ³	16
Interrupt control register 2	ICR2	R/W	H'0000	H'04000012 (H'A4000012)* ³	16
PINT interrupt enable register	PINTER	R/W	H'0000	H'04000014 (H'A4000014)* ³	16
Interrupt priority register A	IPRA	R/W	H'0000	H'FFFFFFE2	16
Interrupt priority register B	IPRB	R/W	H'0000	H'FFFFFFE4	16
Interrupt priority register C	IPRC	R/W	H'0000	H'04000016 (H'A4000016)* ³	16
Interrupt priority register D	IPRD	R/W	H'0000	H'04000018 (H'A4000018)* ³	16
Interrupt priority register E	IPRE	R/W	H'0000	H'0400001A (H'A400001A)* ³	16
Interrupt request register 0	IRR0	R/W	H'00	H'04000004 (H'A4000004)* ³	8
Interrupt request register 1	IRR1	R	H'00	H'04000006 (H'A4000006)* ³	8
Interrupt request register 2	IRR2	R	H'00	H'04000008 (H'A4000008)* ³	8

Notes: 1. Initialized by a power-on or manual reset.

2. H'8000 when the NMI pin is high, H'0000 when the NMI pin is low.

3. When address translation by the MMU does not apply, the address in parentheses should be used.

6.2 Interrupt Sources

There are five types of interrupt sources: NMI, IRQ, IRL,PINT, and on-chip peripheral modules. Each interrupt has a priority level (0–16), with 0 the lowest and 16 the highest. Priority level 0 masks an interrupt.

6.2.1 NMI Interrupt

The NMI interrupt has the highest priority level of 16. When the BLMSK bit in the interrupt control register (ICR1) is 1 or the BL bit in the status register (SR) is 0, NMI interrupts are accepted when the MAI bit in the ICR1 register is 0. NMI interrupts are edge-detected. In sleep or standby mode, the interrupt is accepted regardless of the BL setting. The NMI edge select bit (NMIE) in the interrupt control register 0 (ICR0) is used to select either rising or falling edge detection. When the NMIE bit in the ICR0 register is changed, an NMI interrupt is not detected for 20 cycles after changing ICR0. NMIE to avoid a false detection of NMI. NMI interrupt exception handling does not affect the interrupt mask level bits (I3–I0) in the status register (SR).

When the BL bit is land the BLMSK bit in the ICR1 register is set to 1 and only NMI interrupts are accepted, the SPC register and SSR register are updated by the NMI interrupt handler, making it impossible to return to the original processing from exception handling initiated prior to the NMI interrupt. Use should therefore be restricted to cases where return is not necessary.

It is possible to wake the chip up from the standby state with an NMI interrupt (except when the MAI bit in the ICR1 register is set to 1).

6.2.2 IRQ Interrupts

IRQ interrupts are input by level or edge from pins IRQ0–IRQ5. The priority level can be set by interrupt priority registers C–D (IPRC–IPRD) in a range from 0 to 15.

When using edge-sensing for IRQ interrupts, clear the interrupt source by having software read 1 from the corresponding bit in IRR0, then write 0 to the bit.

When the ICR1 register is rewritten, IRQ interrupts may be mistakenly detected, depending on the pin states. To prevent this, rewrite the register while interrupts are masked, then release the mask after clearing the illegal interrupt by writing 0 to interrupt request register 0 (IRR0).

Edge input interrupt detection requires input of a pulse width of more than two cycles on a peripheral clock ($P\phi$) basis.

The interrupt mask bits (I3–I0) in the status register (SR) are not affected by IRQ interrupt handling.

Interrupts IRQ4–IRQ0 can wake the chip up from the standby state when the relevant interrupt level is higher than the setting of I3–I0 in the SR register (but only when the RTC 32-kHz oscillator is used).

If the IRQ edge is input immediately before the CPU enters the standby mode (during the period between when the CPU executes a SLEEP instruction and when STATUS0 becomes high level), the interrupt may not be detected. However, the interrupt will be accepted correctly if the IRQ edge is re-input after the CPU has entered the standby mode (when STATUS0 is high level). In addition, the interrupt may not be detected if the IRQ edge is input during frequency change processing (WDT count).

6.2.3 IRL Interrupts

IRL interrupts are input by level at pins $\overline{\text{IRL3}}\text{--}\overline{\text{IRL0}}$ and $\overline{\text{IRLS3}}\text{--}\overline{\text{IRLS0}}$. $\overline{\text{IRLS3}}\text{--}\overline{\text{IRLS0}}$ are enabled when the IRQLVL bit and IRLSEN bit in interrupt control register 1 (ICR1) are both 1. The priority level is the higher level indicated by pins $\overline{\text{IRL3}}\text{--}\overline{\text{IRL0}}$ and $\overline{\text{IRLS3}}\text{--}\overline{\text{IRLS0}}$. An $\overline{\text{IRL3}}\text{--}\overline{\text{IRL0}}/\overline{\text{IRLS3}}\text{--}\overline{\text{IRLS0}}$ value of 0 (0000) indicates the highest-level interrupt request (interrupt priority level 15). A value of 15 (1111) indicates no interrupt request (interrupt priority level 0). Figure 6.2 shows an example of IRL interrupt connection. Table 6.3 shows $\overline{\text{IRL}}/\overline{\text{IRLS}}$ pins and interrupt levels.

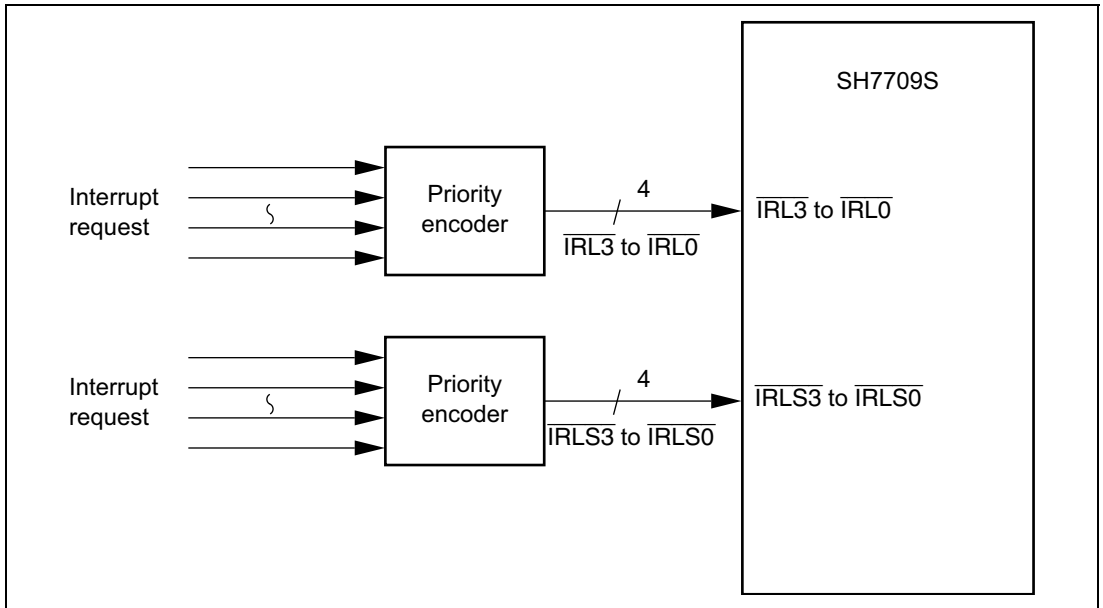

Figure 6.2 Example of IRL Interrupt Connection

Table 6.3 $\overline{\text{IRL3}}\text{--}\overline{\text{IRL0}}/\overline{\text{IRLS3}}\text{--}\overline{\text{IRLS0}}$ Pins and Interrupt Levels

$\overline{\text{IRL3}}/\overline{\text{IRLS3}}$	$\overline{\text{IRL2}}/\overline{\text{IRLS2}}$	$\overline{\text{IRL1}}/\overline{\text{IRLS1}}$	$\overline{\text{IRL0}}/\overline{\text{IRLS0}}$	Interrupt Priority Level	Interrupt Request
0	0	0	0	15	Level 15 interrupt request
0	0	0	1	14	Level 14 interrupt request
0	0	1	0	13	Level 13 interrupt request
0	0	1	1	12	Level 12 interrupt request
0	1	0	0	11	Level 11 interrupt request
0	1	0	1	10	Level 10 interrupt request
0	1	1	0	9	Level 9 interrupt request
0	1	1	1	8	Level 8 interrupt request
1	0	0	0	7	Level 7 interrupt request
1	0	0	1	6	Level 6 interrupt request
1	0	1	0	5	Level 5 interrupt request
1	0	1	1	4	Level 4 interrupt request
1	1	0	0	3	Level 3 interrupt request
1	1	0	1	2	Level 2 interrupt request
1	1	1	0	1	Level 1 interrupt request
1	1	1	1	0	No interrupt request

A noise-cancellation feature is built in, and the IRL interrupt is not detected unless the levels sampled at every peripheral module clock cycle remain unchanged for two consecutive cycles, so that no transient level on the $\overline{\text{IRL}}/\overline{\text{IRLS}}$ pin change is detected. In standby mode, as the peripheral clock is stopped, noise cancellation is performed using the 32-kHz clock for the RTC instead. Therefore when the RTC is not used, interruption by means of IRL interrupts cannot be performed in standby mode.

The priority level of the IRL interrupt must not be lowered until the interrupt is accepted and interrupt handling starts. Correct operation cannot be guaranteed if the level is not maintained. However, the priority level can be changed to a higher one.

The interrupt mask bits (I3–I0) in the status register (SR) are not affected by $\overline{\text{IRL}}/\overline{\text{IRLS}}$ interrupt handling.

When the interrupt level of the IRL interrupt is higher than the level set by the I3–I0 bits in the SR, the IRL interrupt can be used to recover from standby mode (however, this only applies when the RTC is used for 32-kHz oscillator).

6.2.4 PINT Interrupts

PINT interrupts are input by level from pins PINT0–PINT15. The priority level can be set by interrupt priority register D (IPRD) in a range from 0 to 15, in groups of PINT0–PINT7 and PINT8–PINT15.

The PINT0/1 interrupt level should be held until the interrupt is accepted and interrupt handling is started. Correct operation cannot be guaranteed if the level is not maintained.

The interrupt mask bits (I3–I0) in the status register (SR) are not affected by PINT interrupt handling.

PINT0/1 interrupts can wake the chip up from the standby state when the relevant interrupt level is higher than the setting of I3–I0 in the SR register (but only when the RTC 32-kHz oscillator is used).

6.2.5 On-Chip Peripheral Module Interrupts

On-chip peripheral module interrupts are generated by the following ten modules:

- Timer unit (TMU)
- Realtime clock (RTC)
- Serial communication interfaces (SCI, IrDA, SCIF)
- Bus state controller (BSC)
- Watchdog timer (WDT)
- Direct memory access controller (DMAC)
- Analog-to-digital converter (ADC)
- User-debugging interface (UDI)

Not every interrupt source is assigned a different interrupt vector. Sources are reflected in the interrupt event registers (INTEVT and INTEVT2). It is easy to identify sources by using the value of the INTEVT or INTEVT2 register as a branch offset.

A priority level (from 0 to 15) can be set for each module except UDI by writing to interrupt priority registers A, B, and E (IPRA, IPRB, and IPRE). The priority level of the UDI interrupt is 15 (fixed).

The interrupt mask bits (I3–I0) in the status register are not affected by on-chip peripheral module interrupt handling.

TMU and RTC interrupts can wake the chip up from the standby state when the relevant interrupt level is higher than the setting of I3–I0 in the SR register (but only when the RTC 32-kHz oscillator is used).

6.2.6 Interrupt Exception Handling and Priority

Tables 6.4 and 6.5 list the codes for the interrupt event registers (INTEVT and INTEVT2), and the order of interrupt priority. Each interrupt source is assigned a unique code. The start address of the interrupt service routine is common to each interrupt source. This is why, for instance, the value of INTEVT or INTEVT2 is used as offset at the start of the interrupt service routine and branched to in order to identify the interrupt source.

The priority of the on-chip peripheral module, IRQ, and PINT interrupts is set within priority levels 0–15 as required by using interrupt priority registers A–E (IPRA–IPRE). The priority of the on-chip peripheral module, IRQ, and PINT interrupts is set to 0 by a reset.

When the priorities of multiple interrupt sources are set to the same level and such interrupts are generated simultaneously, they are handled according to the default order shown in tables 6.4 and 6.5.

Table 6.4 Interrupt Exception Handling Sources and Priority (IRQ Mode)

Interrupt Source	INTEVT Code (INTEVT2 Code)	Interrupt Priority (Initial Value)	IPR (Bit Numbers)	Priority within IPR Setting Unit	Default Priority	
NMI	H'1C0 (H'1C0)	16	—	—	High	
UDI	H'5E0 (H'5E0)	15	—	—		
IRQ	IRQ0	H'200-3C0* (H'600)	0-15 (0)	IPRC (3-0)		—
	IRQ1	H'200-3C0* (H'620)	0-15 (0)	IPRC (7-4)		—
	IRQ2	H'200-3C0* (H'640)	0-15 (0)	IPRC (11-8)		—
	IRQ3	H'200-3C0* (H'660)	0-15 (0)	IPRC (15-12)		—
	IRQ4	H'200-3C0* (H'680)	0-15 (0)	IPRD (3-0)		—
	IRQ5	H'200-3C0* (H'6A0)	0-15 (0)	IPRD (7-4)		—
PINT	PINT0-7	H'200-3C0* (H'700)	0-15 (0)	IPRD (15-12)		—
	PINT8-15	H'200-3C0* (H'720)	0-15 (0)	IPRD (11-8)		—
DMAC	DEI0	H'200-3C0* (H'800)	0-15 (0)	IPRE (15-12)		High
	DEI1	H'200-3C0* (H'820)				↑
	DEI2	H'200-3C0* (H'840)				↓
	DEI3	H'200-3C0* (H'860)				Low
IrDA	ERI1	H'200-3C0* (H'880)	0-15 (0)	IPRE (11-8)		High
	RXI1	H'200-3C0* (H'8A0)				↑
	BRI1	H'200-3C0* (H'8C0)				↓
	TXI1	H'200-3C0* (H'8E0)				Low
SCIF	ERI2	H'200-3C0* (H'900)	0-15 (0)	IPRE (7-4)		High
	RXI2	H'200-3C0* (H'920)				↑
	BRI2	H'200-3C0* (H'940)				↓
	TXI2	H'200-3C0* (H'960)			Low	
ADC	ADI	H'200-3C0* (H'980)	0-15 (0)	IPRE (3-0)	—	
TMU0	TUNI0	H'400 (H'400)	0-15 (0)	IPRA (15-12)	—	
TMU1	TUNI1	H'420 (H'420)	0-15 (0)	IPRA (11-8)	—	
TMU2	TUNI2	H'440 (H'440)	0-15 (0)	IPRA (7-4)	High	
	TICPI2	H'460 (H'460)			Low	

Interrupt Source		INTEVT Code (INTEVT2 Code)	Interrupt Priority (Initial Value)	IPR (Bit Numbers)	Priority within IPR Setting Unit	Default Priority
RTC	ATI	H'480 (H'480)	0–15 (0)	IPRA (3–0)	High	High
	PRI	H'4A0 (H'4A0)			↕	
	CUI	H'4C0 (H'4C0)			Low	
SCI	ERI	H'4E0 (H'4E0)	0–15 (0)	IPRB (7–4)	High	High
	RXI	H'500 (H'500)			↕	
	TXI	H'520 (H'520)			↕	
	TEI	H'540 (H'540)			Low	
WDT	ITI	H'560 (H'560)	0–15 (0)	IPRB (15–12)	—	Low
REF	RCMI	H'580 (H'580)	0–15 (0)	IPRB (11–8)	High	
	ROVI	H'5A0 (H'5A0)			Low	

Note: * The code corresponding to an interrupt level shown in table 6.6 is set.

Table 6.5 Interrupt Exception Handling Sources and Priority (IRL Mode)

Interrupt Source	INTEVT Code (INTEVT2 Code)	Interrupt Priority (Initial Value)	IPR (Bit Numbers)	Priority within IPR Setting Unit	Default Priority	
NMI	H'1C0 (H'1C0)	16	—	—	High	
UDI	H'5E0 (H'5E0)	15	—	—	↑	
IRL	$\overline{\text{IRL}}(3:0)^{*2} = 0000$	H'200 (H'200)	15	—		—
	$\overline{\text{IRL}}(3:0)^{*2} = 0001$	H'220 (H'220)	14	—		—
	$\overline{\text{IRL}}(3:0)^{*2} = 0010$	H'240 (H'240)	13	—		—
	$\overline{\text{IRL}}(3:0)^{*2} = 0011$	H'260 (H'260)	12	—		—
	$\overline{\text{IRL}}(3:0)^{*2} = 0100$	H'280 (H'280)	11	—		—
	$\overline{\text{IRL}}(3:0)^{*2} = 0101$	H'2A0 (H'2A0)	10	—		—
	$\overline{\text{IRL}}(3:0)^{*2} = 0110$	H'2C0 (H'2C0)	9	—		—
	$\overline{\text{IRL}}(3:0)^{*2} = 0111$	H'2E0 (H'2E0)	8	—		—
	$\overline{\text{IRL}}(3:0)^{*2} = 1000$	H'300 (H'300)	7	—		—
	$\overline{\text{IRL}}(3:0)^{*2} = 1001$	H'320 (H'320)	6	—		—
	$\overline{\text{IRL}}(3:0)^{*2} = 1010$	H'340 (H'340)	5	—		—
	$\overline{\text{IRL}}(3:0)^{*2} = 1011$	H'360 (H'360)	4	—		—
	$\overline{\text{IRL}}(3:0)^{*2} = 1100$	H'380 (H'380)	3	—		—
	$\overline{\text{IRL}}(3:0)^{*2} = 1101$	H'3A0 (H'3A0)	2	—		—
$\overline{\text{IRL}}(3:0)^{*2} = 1110$	H'3C0 (H'3C0)	1	—	—		
IRQ	IRQ4	H'200–3C0 ^{*1} (H'680)	0–15 (0)	IPRD (3–0)	—	
	IRQ5	H'200–3C0 ^{*1} (H'6A0)	0–15 (0)	IPRD (7–4)	—	
PINT	PINT0–7	H'200–3C0 ^{*1} (H'700)	0–15 (0)	IPRD (15–12)	—	
	PINT8–15	H'200–3C0 ^{*1} (H'720)	0–15 (0)	IPRD (11–8)	—	
DMAC	DEI0	H'200–3C0 ^{*1} (H'800)	0–15 (0)	IPRE (15–12)	High	
	DEI1	H'200–3C0 ^{*1} (H'820)			↑	
	DEI2	H'200–3C0 ^{*1} (H'840)			↓	
	DEI3	H'200–3C0 ^{*1} (H'860)			Low	
IrDA	ER11	H'200–3C0 ^{*1} (H'880)	0–15 (0)	IPRE (11–8)	High	
	RX11	H'200–3C0 ^{*1} (H'8A0)			↑	
	BR11	H'200–3C0 ^{*1} (H'8C0)			↓	
	TX11	H'200–3C0 ^{*1} (H'8E0)			Low	

Interrupt Source		INTEVT Code (INTEVT2 Code)	Interrupt Priority (Initial Value)	IPR (Bit Numbers)	Priority within IPR Setting Unit	Default Priority
SCIF	ERI2	H'200–3C0*1 (H'900)	0–15 (0)	IPRE (7–4)	High	↑ ↓ ↓ ↓ ↓ ↓ ↓ ↓ ↓ ↓ ↓
	RX12	H'200–3C0*1 (H'920)			↑	
	BRI2	H'200–3C0*1 (H'940)			↓	
	TX12	H'200–3C0*1 (H'960)			Low	
ADC	ADI	H'200–3C0*1 (H'980)	0–15 (0)	IPRE (3–0)	—	
TMU0	TUN10	H'400 (H'400)	0–15 (0)	IPRA (15–12)	—	
TMU1	TUN11	H'420 (H'420)	0–15 (0)	IPRA (11–8)	—	
TMU2	TUN12	H'440 (H'440)	0–15 (0)	IPRA (7–4)	High	
	TICPI2	H'460 (H'460)			Low	
RTC	ATI	H'480 (H'480)	0–15 (0)	IPRA (3–0)	High	
	PRI	H'4A0 (H'4A0)			↑	
	CUI	H'4C0 (H'4C0)			Low	
SCI	ERI	H'4E0 (H'4E0)	0–15 (0)	IPRB (7–4)	High	
	RXI	H'500 (H'500)			↑	
	TXI	H'520 (H'520)			↓	
	TEI	H'540 (H'540)			Low	
WDT	ITI	H'560 (H'560)	0–15 (0)	IPRB (15–12)	—	
REF	RCMI	H'580 (H'580)	0–15 (0)	IPRB (11–8)	High	
	ROVI	H'5A0 (H'5A0)			Low	

- Notes: 1. The code corresponding to an interrupt level shown in table 6.6 is set.
2. When $\overline{\text{IRLS3}}\text{--}\overline{\text{IRLS0}}$ are enabled, IRL is the higher level of $\overline{\text{IRL3}}\text{--}\overline{\text{IRL0}}$ and $\overline{\text{IRLS3}}\text{--}\overline{\text{IRLS0}}$.

Table 6.6 Interrupt Levels and INTEVT Codes

Interrupt level	INTEVT Code
15	H'200
14	H'220
13	H'240
12	H'260
11	H'280
10	H'2A0
9	H'2C0
8	H'2E0
7	H'300
6	H'320
5	H'340
4	H'360
3	H'380
2	H'3A0
1	H'3C0

6.3 INTC Registers

6.3.1 Interrupt Priority Registers A to E (IPRA–IPRE)

Interrupt priority registers A to E (IPRA to IPRE) are 16-bit readable/writable registers in which priority levels from 0 to 15 are set for on-chip peripheral module, IRQ, and PINT interrupts. These registers are initialized to H'0000 by a power-on reset or manual reset, but are not initialized in standby mode.

Bit:	15	14	13	12	11	10	9	8
Initial value:	0	0	0	0	0	0	0	0
R/W:	R/W	R/W	R/W	R/W	R/W	R/W	R/W	R/W
Bit:	7	6	5	4	3	2	1	0
Initial value:	0	0	0	0	0	0	0	0
R/W:	R/W	R/W	R/W	R/W	R/W	R/W	R/W	R/W

Table 6.7 lists the relationship between the interrupt sources and the IPRA—IPRE bits.

Table 6.7 Interrupt Request Sources and IPRA–IPRE

Register	Bits 15 to 12	Bits 11 to 8	Bits 7 to 4	Bits 3 to 0
IPRA	TMU0	TMU1	TMU2	RTC
IPRB	WDT	REF	SCI0	Reserved*
IPRC	IRQ3	IRQ2	IRQ1	IRQ0
IPRD	PINT0 to PINT7	PINT8 to PINT15	IRQ5	IRQ4
IPRE	DMAC	IrDA	SCIF	ADC

Note: * Always read as 0. Only 0 should be written.

As shown in table 6.7, on-chip peripheral module, IRQ, or PINT interrupts are assigned to four 4-bit groups in each register. These 4-bit groups (bits 15 to 12, bits 11 to 8, bits 7 to 4, and bits 3 to 0) are set with values from H'0 (0000) to H'F (1111). Setting H'0 means priority level 0 (masking is requested); H'F is priority level 15 (the highest level). A reset initializes IPRA–IPRE to H'0000.

6.3.2 Interrupt Control Register 0 (ICR0)

ICR0 is a register that sets the input signal detection mode of external interrupt input pin NMI, and indicates the input signal level at the NMI pin. This register is initialized to H'0000 or H'8000 by a power-on reset or manual reset, but is not initialized in standby mode.

Bit:	15	14	13	12	11	10	9	8
	NMIL	—	—	—	—	—	—	NMIE
Initial value:	0/1*	0	0	0	0	0	0	0
R/W:	R	R	R	R	R	R	R	R/W

Bit:	7	6	5	4	3	2	1	0
	—	—	—	—	—	—	—	—
Initial value:	0	0	0	0	0	0	0	0
R/W:	R	R	R	R	R	R	R	R

Note: * 1 when NMI input is high, 0 when NMI input is low.

Bit 15—NMI Input Level (NMIL): Sets the level of the signal input at the NMI pin. This bit can be read to determine the NMI pin level. This bit cannot be modified.

Bit 15: NMIL Description

0	NMI input level is low
1	NMI input level is high

Bit 8—NMI Edge Select (NMIE): Selects whether the falling or rising edge of the interrupt request signal at the NMI pin is detected.

Bit 8: NMIE Description

0	Interrupt request is detected on falling edge of NMI input
1	Interrupt request is detected on rising edge of NMI input

Bits 14 to 9 and 7 to 0—Reserved: These bits are always read as 0. The write value should always be 0.

6.3.3 Interrupt Control Register 1 (ICR1)

ICR1 is a 16-bit register that specifies the detection mode for external interrupt input pins IRQ0 to IRQ5 individually: rising edge, falling edge, or low level. This register is initialized to H'4000 by a power-on reset or manual reset, but is not initialized in standby mode.

Bit:	15	14	13	12	11	10	9	8
	MAI	IRQLVL	BLMSK	IRLSEN	IRQ51S	IRQ50S	IRQ41S	IRQ40S
Initial value:	0	1	0	0	0	0	0	0
R/W:	R/W	R/W	R/W	R/W	R/W	R/W	R/W	R/W
Bit:	7	6	5	4	3	2	1	0
	IRQ31S	IRQ30S	IRQ21S	IRQ20S	IRQ11S	IRQ10S	IRQ01S	IRQ00S
Initial value:	0	0	0	0	0	0	0	0
R/W:	R/W	R/W	R/W	R/W	R/W	R/W	R/W	R/W

Bit 15—Mask All Interrupts (MAI): When set to 1, all interrupt requests are masked while a low level is being input to the NMI pin. Masks NMI interrupts in standby mode.

Bit 15: MAI	Description
0	All interrupt requests are not masked when NMI pin is low level (Initial value)
1	All interrupt requests are masked when NMI pin is low level

Bit 14—Interrupt Request Level Detect (IRQLVL): Selects whether the IRQ3–IRQ0 pins are used as four independent interrupt pins or as 15-level interrupt pins encoded as $\overline{IRL3}$ – $\overline{IRL0}$.

Bit 14: IRQLVL	Description
0	Used as four independent interrupt request pins IRQ3–IRQ0
1	Used as 15-level interrupt pins encoded as $\overline{IRL3}$ – $\overline{IRL0}$ (Initial value)

Bit 13—BL Bit Mask (BLMSK): Specifies whether NMI interrupts are masked when the BL bit in the SR register is 1.

Bit 13: BLMSK	Description
0	NMI interrupts are masked when BL bit is 1 (Initial value)
1	NMI interrupts are accepted regardless of BL bit setting

Bit 12— $\overline{\text{IRLS}}$ Enable (IRLSEN): Enables pins $\overline{\text{IRLS3}}$ – $\overline{\text{IRLS0}}$. This bit is valid only when the IRQLVL bit is 1.

Bit 12: IRLSEN Description

0	Pins $\overline{\text{IRLS3}}$ – $\overline{\text{IRLS0}}$ disabled	(Initial value)
1	Pins $\overline{\text{IRLS3}}$ – $\overline{\text{IRLS0}}$ enabled	

Bits 11 and 10—IRQ5 Sense Select (IRQ51S, IRQ50S): Select whether the interrupt signal to the IRQ5 pin is detected at the rising edge, at the falling edge, or at the low level.

Bit 11: IRQ51S Bit 10: IRQ50S Description

0	0	An interrupt request is detected at IRQ5 input falling edge (Initial value)
	1	An interrupt request is detected at IRQ5 input rising edge
1	0	An interrupt request is detected at IRQ5 input low level
	1	Reserved

Bits 9 and 8—IRQ4 Sense Select (IRQ41S, IRQ40S): Select whether the interrupt signal to the IRQ4 pin is detected at the rising edge, at the falling edge, or at the low level.

Bit 9: IRQ41S Bit 8: IRQ40S Description

0	0	An interrupt request is detected at IRQ4 input falling edge (Initial value)
	1	An interrupt request is detected at IRQ4 input rising edge
1	0	An interrupt request is detected at IRQ4 input low level
	1	Reserved

Bits 7 and 6—IRQ3 Sense Select (IRQ31S, IRQ30S): Select whether the interrupt signal to the IRQ3 pin is detected at the rising edge, at the falling edge, or at the low level.

Bit 7: IRQ31S Bit 6: IRQ30S Description

0	0	An interrupt request is detected at IRQ3 input falling edge (Initial value)
	1	An interrupt request is detected at IRQ3 input rising edge
1	0	An interrupt request is detected at IRQ3 input low level
	1	Reserved

Bits 5 and 4—IRQ2 Sense Select (IRQ21S, IRQ20S): Select whether the interrupt signal to the IRQ2 pin is detected at the rising edge, at the falling edge, or at the low level.

Bit 5: IRQ21S	Bit 4: IRQ20S	Description
0	0	An interrupt request is detected at IRQ2 input falling edge (Initial value)
	1	An interrupt request is detected at IRQ2 input rising edge
1	0	An interrupt request is detected at IRQ2 input low level
	1	Reserved

Bits 3 and 2—IRQ1 Sense Select (IRQ11S, IRQ10S): Select whether the interrupt signal to the IRQ1 pin is detected at the rising edge, at the falling edge, or at the low level.

Bit 3: IRQ11S	Bit 2: IRQ10S	Description
0	0	An interrupt request is detected at IRQ1 input falling edge (Initial value)
	1	An interrupt request is detected at IRQ1 input rising edge
1	0	An interrupt request is detected at IRQ1 input low level
	1	Reserved

Bits 1 and 0—IRQ0 Sense Select (IRQ01S, IRQ00S): Select whether the interrupt signal to the IRQ0 pin is detected at the rising edge, at the falling edge, or at the low level.

Bit 1: IRQ01S	Bit 0: IRQ00S	Description
0	0	An interrupt request is detected at IRQ0 input falling edge (Initial value)
	1	An interrupt request is detected at IRQ0 input rising edge
1	0	An interrupt request is detected at IRQ0 input low level
	1	Reserved

6.3.4 Interrupt Control Register 2 (ICR2)

ICR2 is a 16-bit readable/writable register that sets the detection mode for external interrupt input pins PINT0 to PINT15. This register is initialized to H'0000 by a power-on reset or manual reset, but is not initialized in standby mode.

Bit:	15	14	13	12	11	10	9	8
	PINT15S	PINT14S	PINT13S	PINT12S	PINT11S	PINT10S	PINT9S	PINT8S
Initial value:	0	0	0	0	0	0	0	0
R/W:	R/W	R/W	R/W	R/W	R/W	R/W	R/W	R/W
Bit:	7	6	5	4	3	2	1	0
	PINT7S	PINT6S	PINT5S	PINT4S	PINT3S	PINT2S	PINT1S	PINT0S
Initial value:	0	0	0	0	0	0	0	0
R/W:	R/W	R/W	R/W	R/W	R/W	R/W	R/W	R/W

Bits 15 to 0—PINT15 to PINT0 Sense Select (PINT15S to PINT0S): Select whether interrupt request signals to PINT15 to PINT0 are detected at the low level or high level.

Bits 15–0:

PINT15S to PINT0S	Description
0	Interrupt requests are detected at low level input to the PINT pin (Initial value)
1	Interrupt requests are detected at high level input to the PINT pin

6.3.5 PINT Interrupt Enable Register (PINTER)

PINTER is a 16-bit readable/writable register that enables interrupt requests input to external interrupt input pins PINT0 to PINT15. This register is initialized to H'0000 by a power-on reset or manual reset, but is not initialized in standby mode.

Bit:	15	14	13	12	11	10	9	8
	PINT15E	PINT14E	PINT13E	PINT12E	PINT11E	PINT10E	PINT9E	PINT8E
Initial value:	0	0	0	0	0	0	0	0
R/W:	R/W	R/W	R/W	R/W	R/W	R/W	R/W	R/W
Bit:	7	6	5	4	3	2	1	0
	PINT7E	PINT6E	PINT5E	PINT4E	PINT3E	PINT2E	PINT1E	PINT0E
Initial value:	0	0	0	0	0	0	0	0
R/W:	R/W	R/W	R/W	R/W	R/W	R/W	R/W	R/W

Bits 15 to 0—PINT15 to PINT0 Interrupt Enable (PINT15E to PINT0E): Enable or disable interrupt request input to pins PINT15 to PINT0.

Bits 15–0:

PINT15E to PINT0E	Description
0	PINT input interrupt requests disabled (Initial value)
1	PINT input interrupt requests enabled

When all or some of pins PINT0–PINT15 are not used for interrupt input, bits corresponding to pins not used as interrupt request pins should be cleared to 0.

6.3.6 Interrupt Request Register 0 (IRR0)

IRR0 is an 8-bit register that indicates interrupt requests from external input pins IRQ0 to IRQ5 and PINT0 to PINT15. This register is initialized to H'00 by a power-on reset or manual reset, but is not initialized in standby mode.

Bit:	7	6	5	4	3	2	1	0
	PINT0R	PINT1R	IRQ5R	IRQ4R	IRQ3R	IRQ2R	IRQ1R	IRQ0R
Initial value:	0	0	0	0	0	0	0	0
R/W:	R	R	R/W	R/W	R/W	R/W	R/W	R/W

When clearing an IRQ5R–IRQ0R bit to 0, read the bit while bit set to 1, and then write 0. In this case, 0 should be written only to the bits to be cleared and 1 to the other bits. The contents of the bits to which 1 is written do not change.

Bit 7—PINT0 to PINT7 Interrupt Request (PINT0R): Indicates whether there is interrupt request input to pins PINT0 to PINT7.

Bit 7: PINT0R Description

0	No interrupt request to pins PINT0 to PINT7	(Initial value)
1	Interrupt to pins PINT0 to PINT7	

Bit 6—PINT8 to PINT15 Interrupt Request (PINT1R): Indicates whether there is interrupt request input to pins PINT8 to PINT15.

Bit 6: PINT1R Description

0	No interrupt request input to pins PINT8 to PINT15	(Initial value)
1	Interrupt request input to pins PINT8 to PINT15	

Bit 5—IRQ5 Interrupt Request (IRQ5R): Indicates whether there is interrupt request input to the IRQ5 pin. When edge detection mode is set for IRQ5, an interrupt request is cleared by clearing the IRQ5R bit.

Bit 5: IRQ5R Description

0	No interrupt request input to IRQ5 pin	(Initial value)
1	Interrupt request input to IRQ5 pin	

Bit 4—IRQ4 Interrupt Request (IRQ4R): Indicates whether there is interrupt request input to the IRQ4 pin. When edge detection mode is set for IRQ4, an interrupt request is cleared by clearing the IRQ4R bit.

Bit 4: IRQ4R	Description
0	No interrupt request input to IRQ4 pin (Initial value)
1	Interrupt request input to IRQ4 pin

Bit 3—IRQ3 Interrupt Request (IRQ3R): Indicates whether there is interrupt request input to the IRQ3 pin. When edge detection mode is set for IRQ3, an interrupt request is cleared by clearing the IRQ3R bit.

Bit 3: IRQ3R	Description
0	No interrupt request input to IRQ3 pin (Initial value)
1	Interrupt request input to IRQ3 pin

Bit 2—IRQ2 Interrupt Request (IRQ2R): Indicates whether there is interrupt request input to the IRQ2 pin. When edge detection mode is set for IRQ2, an interrupt request is cleared by clearing the IRQ2R bit.

Bit 2: IRQ2R	Description
0	No interrupt request input to IRQ2 pin (Initial value)
1	Interrupt request input to IRQ2 pin

Bit 1—IRQ1 Interrupt Request (IRQ1R): Indicates whether there is interrupt request input to the IRQ1 pin. When edge detection mode is set for IRQ1, an interrupt request is cleared by clearing the IRQ1R bit.

Bit 1: IRQ1R	Description
0	No interrupt request input to IRQ1 pin (Initial value)
1	Interrupt request input to IRQ1 pin

Bit 0—IRQ0 Interrupt Request (IRQ0R): Indicates whether there is interrupt request input to the IRQ0 pin. When edge detection mode is set for IRQ0, an interrupt request is cleared by clearing the IRQ0R bit.

Bit 0: IRQ0R	Description
0	No interrupt request input to IRQ0 pin (Initial value)
1	Interrupt request input to IRQ0 pin

6.3.7 Interrupt Request Register 1 (IRR1)

IRR1 is an 8-bit read-only register that indicates whether DMAC or IrDA interrupt requests have been generated. This register is initialized to H'00 by a power-on reset or manual reset, but is not initialized in standby mode.

Bit:	7	6	5	4	3	2	1	0
	TXI1R	BRI1R	RXI1R	ERI1R	DEI3R	DEI2R	DEI1R	DEI0R
Initial value:	0	0	0	0	0	0	0	0
R/W:	R	R	R	R	R	R	R	R

Bit 7—TXI1 Interrupt Request (TXI1R): Indicates whether a TXI1 (IrDA) interrupt request has been generated.

Bit 7: TXI1	Description
0	TXI1 interrupt request not generated (Initial value)
1	TXI1 interrupt request generated

Bit 6—BRI1 Interrupt Request (BRI1R): Indicates whether a BRI1 (IrDA) interrupt request has been generated.

Bit 6: BRI1R	Description
0	BRI1 interrupt request not generated (Initial value)
1	BRI1 interrupt request generated

Bit 5—RXI1 Interrupt Request (RXI1R): Indicates whether an RXI1 (IrDA) interrupt request has been generated.

Bit 5: RXI1R	Description
0	RXI1 interrupt request not generated (Initial value)
1	RXI1 interrupt request generated

Bit 4—ERI1 Interrupt Request (ERI1R): Indicates whether an ERI1 (IrDA) interrupt request has been generated.

Bit 4: ERI1R	Description
0	ERI1 interrupt request not generated (Initial value)
1	ERI1 interrupt request generated

Bit 3—DEI3 Interrupt Request (DEI3R): Indicates whether a DEI3 (DMAC) interrupt request has been generated.

Bit 3: DEI3R	Description
0	DEI3 interrupt request not generated (Initial value)
1	DEI3 interrupt request generated

Bit 2—DEI2 Interrupt Request (DEI2R): Indicates whether a DEI2 (DMAC) interrupt request has been generated.

Bit 2: DEI2R	Description
0	DEI2 interrupt request not generated (Initial value)
1	DEI2 interrupt request generated

Bit 1—DEI1 Interrupt Request (DEI1R): Indicates whether a DEI1 (DMAC) interrupt request has been generated.

Bit 1: DEI1R	Description
0	DEI1 interrupt request not generated (Initial value)
1	DEI1 interrupt request generated

Bit 0—DEI0 Interrupt Request (DEI0R): Indicates whether a DEI0 (DMAC) interrupt request has been generated.

Bit 0: DEI0R	Description
0	DEI0 interrupt request not generated (Initial value)
1	DEI0 interrupt request generated

6.3.8 Interrupt Request Register 2 (IRR2)

IRR2 is an 8-bit read-only register that indicates whether an A/D converter or SCIF interrupt request has been generated. This register is initialized to H'00 by a power-on reset or manual reset, but is not initialized in standby mode.

Bit:	7	6	5	4	3	2	1	0
	—	—	—	ADIR	TXI2R	BRI2R	RXI2R	ERI2R
Initial value:	0	0	0	0	0	0	0	0
R/W:	R	R	R	R	R	R	R	R

Bits 7 to 5—Reserved: These bits are always read as 0. The write value should always be 0.

Bit 4—ADI Interrupt Request (ADIR): Indicates whether an ADI (ADC) interrupt request has been generated.

Bit 4: ADIR	Description
0	ADI interrupt request not generated (Initial value)
1	ADI interrupt request generated

Bit 3—TXI2 Interrupt Request (TXI2R): Indicates whether a TXI2 (SCIF) interrupt request has been generated.

Bit 3: TXI2R	Description
0	TXI2 interrupt request not generated (Initial value)
1	TXI2 interrupt request generated

Bit 2—BRI2 Interrupt Request (BRI2R): Indicates whether a BRI2 (SCIF) interrupt request has been generated.

Bit 2: BRI2R	Description
0	BRI2 interrupt request not generated (Initial value)
1	BRI2 interrupt request generated

Bit 1—RXI2 Interrupt Request (RXI2R): Indicates whether an RXI2 (SCIF) interrupt request has been generated.

Bit 1: RXI2R	Description
0	RXI2 interrupt request not generated (Initial value)
1	RXI2 interrupt request generated

Bit 0—ERI2 Interrupt Request (ERI2R): Indicates whether an ERI2 (SCIF) interrupt request has been generated.

Bit 0: ERI2R	Description
0	ERI2 interrupt request not generated (Initial value)
1	ERI2 interrupt request generated

6.4 INTC Operation

6.4.1 Interrupt Sequence

The sequence of interrupt operations is described below. Figure 6.3 is a flowchart of the operations.

1. The interrupt request sources send interrupt request signals to the interrupt controller.
2. The interrupt controller selects the highest-priority interrupt from the interrupt requests sent, following the priority levels set in interrupt priority registers A to E (IPRA to IPRE). Lower priority interrupts are held pending. If two of these interrupts have the same priority level or if multiple interrupts occur within a single module, the interrupt with the highest default priority or the highest priority within its IPR setting unit (as indicated in tables 6.4 and 6.5) is selected.
3. The priority level of the interrupt selected by the interrupt controller is compared with the interrupt mask bits (I3–I0) in the status register (SR) of the CPU. If the request priority level is higher than the level in bits I3–I0, the interrupt controller accepts the interrupt and sends an interrupt request signal to the CPU. When the interrupt controller receives an interrupt, a low level is output from the $\overline{\text{IRQOUT}}$ pin.
4. Detection timing: The INTC operates, and notifies the CPU of interrupt requests, in synchronization with the peripheral clock ($P\phi$). The CPU receives an interrupt at a break in instructions.
5. The interrupt source code is set in the interrupt event registers (INTEVT and INTEVT2).
6. The status register (SR) and program counter (PC) are saved to SSR and SPC, respectively.
7. The block bit (BL), mode bit (MD), and register bank bit (RB) in SR are set to 1.
8. The CPU jumps to the start address of the interrupt handler (the sum of the value set in the vector base register (VBR) and H'00000600). This jump is not a delayed branch. The interrupt handler may branch with the INTEVT and INTEVT2 register value as its offset in order to identify the interrupt source. This enables it to branch to the handling routine for the individual interrupt source.

- Notes:
1. The interrupt mask bits (I3–I0) in the status register (SR) are not changed by acceptance of an interrupt in the SH7709S.
 2. $\overline{\text{IRQOUT}}$ outputs a low level until the interrupt request is cleared. However, if the interrupt source is masked by an interrupt mask bit, the $\overline{\text{IRQOUT}}$ pin returns to the high level. The level is output without regard to the BL bit.
 3. The interrupt source flag should be cleared in the interrupt handler. To ensure that an interrupt request that should have been cleared is not inadvertently accepted again, read the interrupt source flag after it has been cleared, then wait for the interval shown in table 6.8 (Time for priority decision and SR mask bit comparison) before clearing the BL bit or executing an RTE instruction.

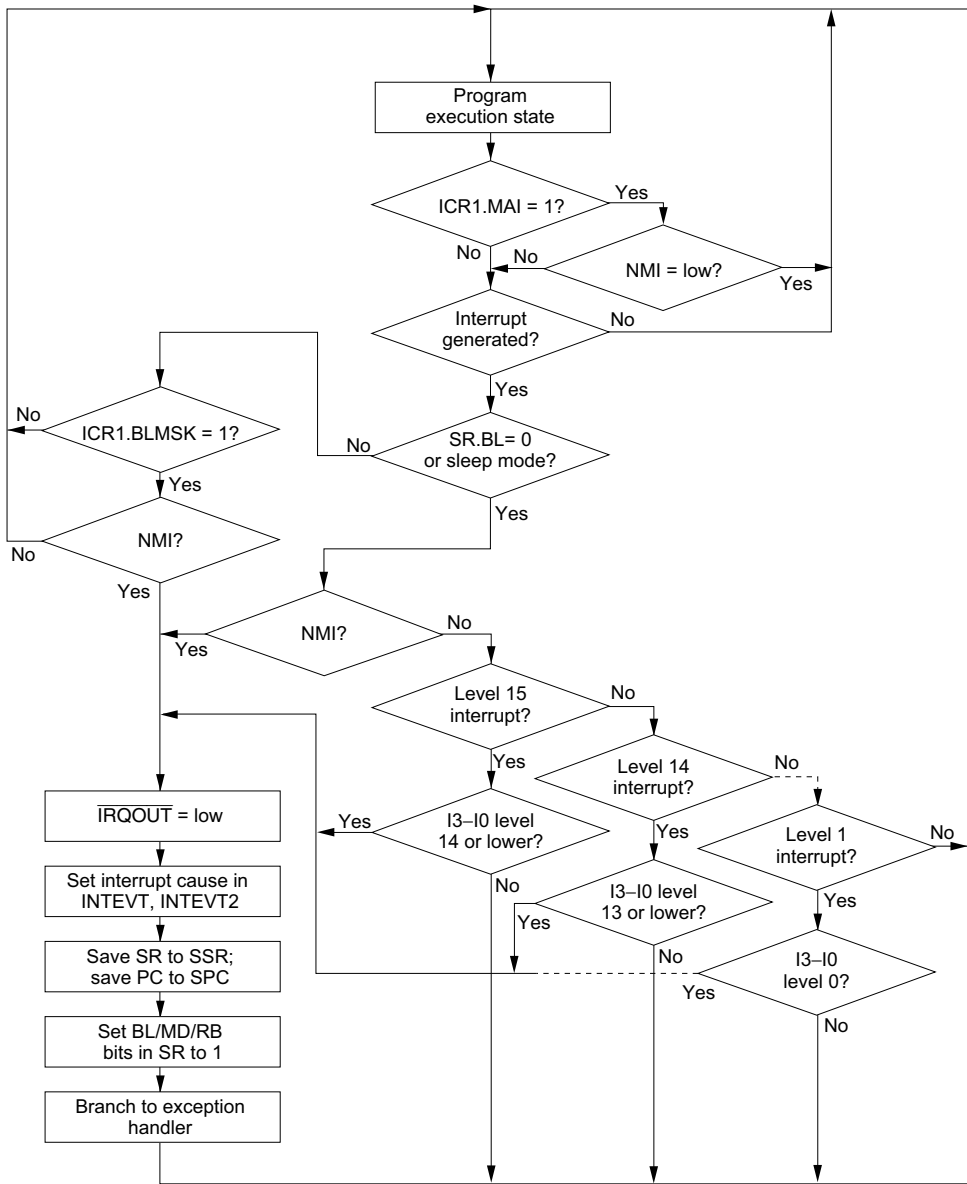

I3-I0: Interrupt mask bits in status register (SR)

Figure 6.3 Interrupt Operation Flowchart

6.4.2 Multiple Interrupts

When handling multiple interrupts, an interrupt handler should include the following procedures:

1. Branch to a specific interrupt handler corresponding to a code set in INTEVT and INTEVT2. The code in INTEVT and INTEVT2 can be used as a branch-offset for branching to the specific handler.
2. Clear the cause of the interrupt in each specific handler.
3. Save SSR and SPC to memory.
4. Clear the BL bit in SR, and set the accepted interrupt level in the interrupt mask bits in SR.
5. Handle the interrupt.
6. Execute the RTE instruction.

When these procedures are followed in order, an interrupt of higher priority than the one being handled can be accepted after clearing BL in step 4. Figure 6.3 shows a sample interrupt operation flowchart.

6.5 Interrupt Response Time

The time from generation of an interrupt request until interrupt exception handling is performed and fetching of the first instruction of the exception handler is started (the interrupt response time) is shown in table 6.8. Figure 6.4 shows an example of pipeline operation when an IRL interrupt is accepted. When SR.BL is 1, interrupt exception handling is masked, and is kept waiting until completion of an instruction that clears BL to 0.

Table 6.8 Interrupt Response Time

Item	Number of States				Notes
	NMI	IRQ	PINT	Peripheral Modules	
Time for priority decision and SR mask bit comparison	$0.5 \times \text{Icyc}$ $+ 0.5 \times \text{Bcyc}$ $+ 0.5 \times \text{Pcyc}$	$0.5 \times \text{Icyc}$ $+ 1 \times \text{Bcyc}$ $+ 4.5 \times \text{Pcyc}^{*4}$	$0.5 \times \text{Icyc}$ $+ 3.5 \times \text{Pcyc}$	$0.5 \times \text{Icyc}$ $+ 1.5 \times \text{Pcyc}^{*5}$ <hr/> $0.5 \times \text{Icyc}$ $+ 3 \times \text{Pcyc}^{*6}$	
Wait time until end of sequence being executed by CPU	$X (\geq 0) \times \text{Icyc}$	$X (\geq 0) \times \text{Icyc}$	$X (\geq 0) \times \text{Icyc}$	$X (\geq 0) \times \text{Icyc}$	Interrupt exception handling is kept waiting until the executing instruction ends. If the number of instruction execution states is S^{*1} , the maximum wait time is: $X = S - 1$. However, if BL is set to 1 by instruction execution or by an exception, interrupt exception handling is deferred until completion of an instruction that clears BL to 0. If the following instruction masks interrupt exception handling, the handling may be further deferred.
Time from interrupt exception handling (save of SR and PC) until fetch of first instruction of exception handler is started	$5 \times \text{Icyc}$	$5 \times \text{Icyc}$	$5 \times \text{Icyc}$	$5 \times \text{Icyc}$	

Number of States

Item		NMI	IRQ	PINT	Peripheral Modules	Notes
Response time	Total	$(5.5 + X) \times \text{Icyc} + 0.5 \times \text{Bcyc} + 0.5 \times \text{Pcyc}$	$(5.5 + X) \times \text{Icyc} + 1 \times \text{Bcyc} + 4.5 \times \text{Pcyc}^{*4}$	$(5.5 + X) \times \text{Icyc} + 3.5 \times \text{Pcyc}^{*5}$	$(5.5 + X) \times \text{Icyc} + 1.5 \times \text{Pcyc}^{*5}$	
	Minimum case ^{*2}	7.5	16.5	12.5	$8.5^{*5}/11.5^{*6}$	At 60-MHz (CKIO = 30) operation: 0.13–0.28 μs
	Maximum case ^{*3}	$8.5 + S$	$26.5 + S$	$18.5 + S$	$10.5 + S^{*5}$ $16.5 + S^{*6}$	At 60-MHz (CKIO = 15) operation: 0.26–0.56 μs (in case of operand cache-hit) At 60-MHz (CKIO = 15) operation: 0.29–0.59 μs (when external memory access is performed with wait = 0)

Icyc: Duration of one cycle of internal clock supplied to CPU.

Bcyc: Duration of one CKIO cycle.

Pcyc: Duration of one cycle of peripheral clock supplied to peripheral modules.

Notes: 1. S also includes the memory access wait time.

The processing requiring the maximum execution time is LDC.L @Rm+, SR. When the memory access is a cache-hit, this requires seven instruction execution cycles. When the external access is performed, the corresponding number of cycles must be added. There are also instructions that perform two external memory accesses; if the external memory access is slow, the number of instruction execution cycles will increase accordingly.

2. The internal clock:CKIO:peripheral clock ratio is 2:1:1.
3. The internal clock:CKIO:peripheral clock ratio is 4:1:1.
4. IRQ mode
5. Modules: TMU, RTC, SCI, WDT, REFC
6. Modules: DMAC, ADC, IrDA, SCIF

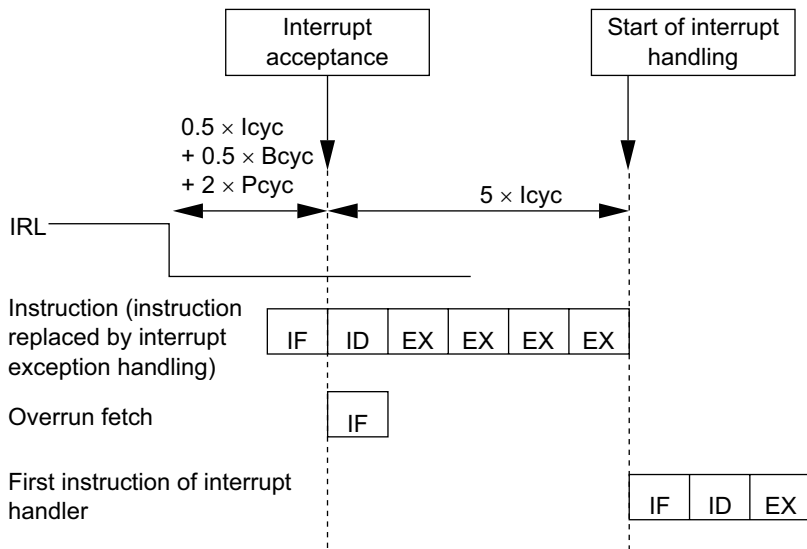

IF: Instruction fetch: Instruction is fetched from memory in which program is stored.
 ID: Instruction decode: Fetched instruction is decoded.
 EX: Instruction execution: Data operation and address calculation are performed.

Figure 6.4 Example of Pipeline Operations when IRL Interrupt is Accepted

Section 7 User Break Controller

7.1 Overview

The user break controller (UBC) provides functions that simplify program debugging. This function makes it easy to design an effective self-monitoring debugger, enabling the chip to debug programs without using an in-circuit emulator. Break conditions that can be set in the UBC are instruction fetch or data read/write, data size, data content, address value, and stop timing during instruction fetches.

7.1.1 Features

The user break controller has the following features:

- The following break comparison conditions can be set.
Number of break channels: two channels (channels A and B)
User break can be requested as either the independent or sequential condition on channels A and B (sequential break setting: channel A and, then channel B match with logical AND, but not in the same bus cycle).
 - Address (Compares 40 bits comprised of a 32-bit logical address prefixed with an ASID address. Comparison bits are maskable in 32-bit units, user can easily program it to mask addresses at bottom 12 bits (4-k page), bottom 10 bits (1-k page), or any size of page, etc.
 - One of two address buses (CPU address bus (LAB), cache address bus (IAB)) can be selected.
 - Data (only on channel B, 32-bit maskable)
 - One of the two data buses (CPU data bus (LDB), cache data bus (IDB)) can be selected.
 - Bus master: CPU cycle or DMAC cycle
 - Bus cycle: instruction fetch or data access
 - Read/write
 - Operand size: byte, word, or longword
- User break is generated upon satisfying break conditions. A user-designed user-break condition exception processing routine can be run.
- In an instruction fetch cycle, it can be selected that a break is set before or after an instruction is executed.
- Maximum repeat times for the break condition: $2^{12} - 1$ times.
- Eight pairs of branch source/destination buffers.

7.1.2 Block Diagram

Figure 7.1 shows a block diagram of the UBC.

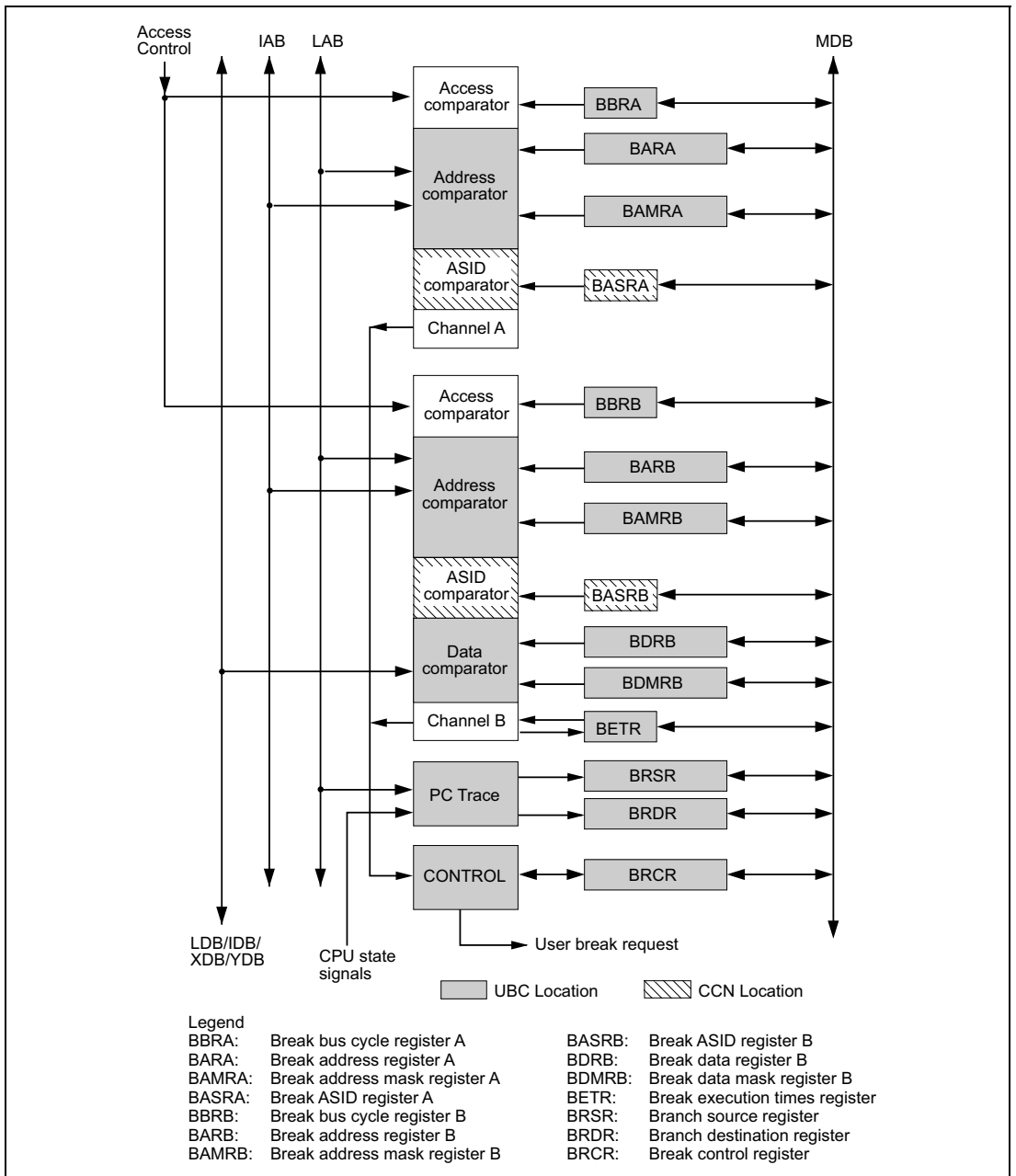

Figure 7.1 Block Diagram of User Break Controller

7.1.3 Register Configuration

Table 7.1 Register Configuration

Name	Abbr.	R/W	Initial Value ^{*1}	Address	Access Size	Location
Break address register A	BARA	R/W	H'00000000	H'FFFFFFB0	32	UBC
Break address mask register A	BAMRA	R/W	H'00000000	H'FFFFFFB4	32	UBC
Break bus cycle register A	BBRA	R/W	H'0000	H'FFFFFFB8	16	UBC
Break address register B	BARB	R/W	H'00000000	H'FFFFFFA0	32	UBC
Break address mask register B	BAMRB	R/W	H'00000000	H'FFFFFFA4	32	UBC
Break bus cycle register B	BBRB	R/W	H'0000	H'FFFFFFA8	16	UBC
Break data register B	BDRB	R/W	H'00000000	H'FFFFFF90	32	UBC
Break data mask register B	BDMRB	R/W	H'00000000	H'FFFFFF94	32	UBC
Break control register	BRCR	R/W	H'00000000	H'FFFFFF98	32	UBC
Execution count break register	BETR	R/W	H'0000	H'FFFFFF9C	16	UBC
Branch source register	BRSR	R	Undefined ^{*2}	H'FFFFFFAC	32	UBC
Branch destination register	BRDR	R	Undefined ^{*2}	H'FFFFFFBC	32	UBC
Break ASID register A	BASRA	R/W	Undefined	H'FFFFFFE4	16	CCN
Break ASID register B	BASRB	R/W	Undefined	H'FFFFFFE8	16	CCN

- Notes: 1. Initialized by power-on reset. Values held in standby state and undefined by manual resets.
2. Bit 31 of BRSR and BRDR (valid flag) is initialized by power-on resets. But other bits are not initialized.

7.2 Register Descriptions

7.2.1 Break Address Register A (BARA)

BARA is a 32-bit read/write register. BARA specifies the address used as a break condition in channel A. A power-on reset initializes BARA to H'00000000.

Bit:	31	30	29	28	27	26	25	24
	BAA31	BAA30	BAA29	BAA28	BAA27	BAA26	BAA25	BAA24
Initial value:	0	0	0	0	0	0	0	0
R/W:	R/W	R/W	R/W	R/W	R/W	R/W	R/W	R/W

Bit:	23	22	21	20	19	18	17	16
	BAA23	BAA22	BAA21	BAA20	BAA19	BAA18	BAA17	BAA16
Initial value:	0	0	0	0	0	0	0	0
R/W:	R/W	R/W	R/W	R/W	R/W	R/W	R/W	R/W

Bit:	15	14	13	12	11	10	9	8
	BAA15	BAA14	BAA13	BAA12	BAA11	BAA10	BAA9	BAA8
Initial value:	0	0	0	0	0	0	0	0
R/W:	R/W	R/W	R/W	R/W	R/W	R/W	R/W	R/W

Bit:	7	6	5	4	3	2	1	0
	BAA7	BAA6	BAA5	BAA4	BAA3	BAA2	BAA1	BAA0
Initial value:	0	0	0	0	0	0	0	0
R/W:	R/W	R/W	R/W	R/W	R/W	R/W	R/W	R/W

Bits 31 to 0—Break Address A31 to A0 (BAA31 to BAA0): Stores the address on the LAB or IAB specifying break conditions of channel A.

7.2.2 Break Address Mask Register A (BAMRA)

BAMRA is a 32-bit read/write register. BAMRA specifies bits masked in the break address specified by BARA. A power-on reset initializes BAMRA to H'00000000.

Bit:	31	30	29	28	27	26	25	24
	BAMA31	BAMA30	BAMA29	BAMA28	BAMA27	BAMA26	BAMA25	BAMA24
Initial value:	0	0	0	0	0	0	0	0
R/W:	R/W	R/W	R/W	R/W	R/W	R/W	R/W	R/W
Bit:	23	22	21	20	19	18	17	16
	BAMA23	BAMA22	BAMA21	BAMA20	BAMA19	BAMA18	BAMA17	BAMA16
Initial value:	0	0	0	0	0	0	0	0
R/W:	R/W	R/W	R/W	R/W	R/W	R/W	R/W	R/W
Bit:	15	14	13	12	11	10	9	8
	BAMA15	BAMA14	BAMA13	BAMA12	BAMA11	BAMA10	BAMA9	BAMA8
Initial value:	0	0	0	0	0	0	0	0
R/W:	R/W	R/W	R/W	R/W	R/W	R/W	R/W	R/W
Bit:	7	6	5	4	3	2	1	0
	BAMA7	BAMA6	BAMA5	BAMA4	BAMA3	BAMA2	BAMA1	BAMA0
Initial value:	0	0	0	0	0	0	0	0
R/W:	R/W	R/W	R/W	R/W	R/W	R/W	R/W	R/W

Bits 31 to 0—Break Address Mask Register A31 to A0 (BAMA31 to BAMA0): Specifies bits masked in the channel A break address bits specified by BARA (BAA31–BAA0).

Bits 31 to 0:

BAMAn	Description
0	Break address bit BAA _n of channel A is included in the break condition (Initial value)
1	Break address bit BAA _n of channel A is masked and is not included in the break condition

n = 31 to 0

7.2.3 Break Bus Cycle Register A (BBRA)

Break bus cycle register A (BBRA) is a 16-bit read/write register, which specifies (1) CPU cycle or DMAC cycle, (2) instruction fetch or data access, (3) read or write, and (4) operand size in the break conditions of channel A. A power-on reset initializes BBRA to H'0000.

Bit:	15	14	13	12	11	10	9	8
	—	—	—	—	—	—	—	—
Initial value:	0	0	0	0	0	0	0	0
R/W:	R	R	R	R	R	R	R	R
Bit:	7	6	5	4	3	2	1	0
	CDA1	CDA0	IDA1	IDA0	RWA1	RWA0	SZA1	SZA0
Initial value:	0	0	0	0	0	0	0	0
R/W:	R/W	R/W	R/W	R/W	R/W	R/W	R/W	R/W

Bits 15 to 8—Reserved: These bits are always read as 0. The write value should always be 0.

Bits 7 and 6—CPU Cycle/DMAC Cycle Select A (CDA1, CDA0): Selects the CPU cycle or DMAC cycle as the bus cycle of the channel A break condition.

Bit 7: CDA1	Bit 6: CDA0	Description
0	0	Condition comparison is not performed (Initial value)
*	1	The break condition is the CPU cycle
1	0	The break condition is the DMAC cycle

*: Don't care

Bits 5 and 4—Instruction Fetch/Data Access Select A (IDA1, IDA0): Selects the instruction fetch cycle or data access cycle as the bus cycle of the channel A break condition.

Bit 5: IDA1	Bit 4: IDA0	Description
0	0	Condition comparison is not performed (Initial value)
	1	The break condition is the instruction fetch cycle
1	0	The break condition is the data access cycle
	1	The break condition is the instruction fetch cycle or data access cycle

Bits 3 and 2—Read/Write Select A (RWA1, RWA0): Selects the read cycle or write cycle as the bus cycle of the channel A break condition.

Bit 3: RWA1	Bit 2: RWA0	Description
0	0	Condition comparison is not performed (Initial value)
	1	The break condition is the read cycle
1	0	The break condition is the write cycle
	1	The break condition is the read cycle or write cycle

Bits 1 and 0—Operand Size Select A (SZA1, SZA0): Selects the operand size of the bus cycle for the channel A break condition.

Bit 1: SZA1	Bit 0: SZA0	Description
0	0	The break condition does not include operand size (Initial value)
	1	The break condition is byte access
1	0	The break condition is word access
	1	The break condition is longword access

7.2.4 Break Address Register B (BARB)

BARB is a 32-bit read/write register. BARB specifies the address used as a break condition in channel B. A power-on reset initializes BARB to H'00000000.

Bit:	31	30	29	28	27	26	25	24
	BAB31	BAB30	BAB29	BAB28	BAB27	BAB26	BAB25	BAB24
Initial value:	0	0	0	0	0	0	0	0
R/W:	R/W	R/W	R/W	R/W	R/W	R/W	R/W	R/W
Bit:	23	22	21	20	19	18	17	16
	BAB23	BAB22	BAB21	BAB20	BAB19	BAB18	BAB17	BAB16
Initial value:	0	0	0	0	0	0	0	0
R/W:	R/W	R/W	R/W	R/W	R/W	R/W	R/W	R/W
Bit:	15	14	13	12	11	10	9	8
	BAB15	BAB14	BAB13	BAB12	BAB11	BAB10	BAB9	BAB8
Initial value:	0	0	0	0	0	0	0	0
R/W:	R/W	R/W	R/W	R/W	R/W	R/W	R/W	R/W
Bit:	7	6	5	4	3	2	1	0
	BAB7	BAB6	BAB5	BAB4	BAB3	BAB2	BAB1	BAB0
Initial value:	0	0	0	0	0	0	0	0
R/W:	R/W	R/W	R/W	R/W	R/W	R/W	R/W	R/W

7.2.5 Break Address Mask Register B (BAMRB)

BAMRB is a 32-bit read/write register. BAMRB specifies bits masked in the break address specified by BARB. A power-on reset initializes BAMRB to H'00000000.

Bit:	31	30	29	28	27	26	25	24
	BAMB31	BAMB30	BAMB29	BAMB28	BAMB27	BAMB26	BAMB25	BAMB24
Initial value:	0	0	0	0	0	0	0	0
R/W:	R/W	R/W	R/W	R/W	R/W	R/W	R/W	R/W
Bit:	23	22	21	20	19	18	17	16
	BAMB23	BAMB22	BAMB21	BAMB20	BAMB19	BAMB18	BAMB17	BAMB16
Initial value:	0	0	0	0	0	0	0	0
R/W:	R/W	R/W	R/W	R/W	R/W	R/W	R/W	R/W
Bit:	15	14	13	12	11	10	9	8
	BAMB15	BAMB14	BAMB13	BAMB12	BAMB11	BAMB10	BAMB9	BAMB8
Initial value:	0	0	0	0	0	0	0	0
R/W:	R/W	R/W	R/W	R/W	R/W	R/W	R/W	R/W
Bit:	7	6	5	4	3	2	1	0
	BAMB7	BAMB6	BAMB5	BAMB4	BAMB3	BAMB2	BAMB1	BAMB0
Initial value:	0	0	0	0	0	0	0	0
R/W:	R/W	R/W	R/W	R/W	R/W	R/W	R/W	R/W

Bits 31 to 0—Break Address Mask Register B31 to B0 (BAMB31 to BAMB0): Specifies bits masked in the channel B break address bits specified by BARB (BAB31—BAB0).

Bits 31 to 0:

BAMBn	Description
0	Break address BABn of channel B is included in the break condition (Initial value)
1	Break address BABn of channel B is masked and is not included in the break condition

n = 31 to 0

7.2.6 Break Data Register B (BDRB)

BDRB is a 32-bit read/write register. A power-on reset initializes BDRB to H'00000000.

Bit:	31	30	29	28	27	26	25	24
	BDB31	BDB30	BDB29	BDB28	BDB27	BDB26	BDB25	BDB24
Initial value:	0	0	0	0	0	0	0	0
R/W:	R/W	R/W	R/W	R/W	R/W	R/W	R/W	R/W
Bit:	23	22	21	20	19	18	17	16
	BDB23	BDB22	BDB21	BDB20	BDB19	BDB18	BDB17	BDB16
Initial value:	0	0	0	0	0	0	0	0
R/W:	R/W	R/W	R/W	R/W	R/W	R/W	R/W	R/W
Bit:	15	14	13	12	11	10	9	8
	BDB15	BDB14	BDB13	BDB12	BDB11	BDB10	BDB9	BDB8
Initial value:	0	0	0	0	0	0	0	0
R/W:	R/W	R/W	R/W	R/W	R/W	R/W	R/W	R/W
Bit:	7	6	5	4	3	2	1	0
	BDB7	BDB6	BDB5	BDB4	BDB3	BDB2	BDB1	BDB0
Initial value:	0	0	0	0	0	0	0	0

7.2.7 Break Data Mask Register B (BDMRB)

BDMRB is a 32-bit read/write register. BDMRB specifies bits masked in the break data specified by BDRB. A power-on reset initializes BDMRB to H'00000000.

Bit:	31	30	29	28	27	26	25	24
	BDMB31	BDMB30	BDMB29	BDMB28	BDMB27	BDMB26	BDMB25	BDMB24
Initial value:	0	0	0	0	0	0	0	0
R/W:	R/W	R/W	R/W	R/W	R/W	R/W	R/W	R/W
Bit:	23	22	21	20	19	18	17	16
	BDMB23	BDMB22	BDMB21	BDMB20	BDMB19	BDMB18	BDMB17	BDMB16
Initial value:	0	0	0	0	0	0	0	0
R/W:	R/W	R/W	R/W	R/W	R/W	R/W	R/W	R/W
Bit:	15	14	13	12	11	10	9	8
	BDMB15	BDMB14	BDMB13	BDMB12	BDMB11	BDMB10	BDMB9	BDMB8
Initial value:	0	0	0	0	0	0	0	0
R/W:	R/W	R/W	R/W	R/W	R/W	R/W	R/W	R/W
Bit:	7	6	5	4	3	2	1	0
	BDMB7	BDMB6	BDMB5	BDMB4	BDMB3	BDMB2	BDMB1	BDMB0
Initial value:	0	0	0	0	0	0	0	0
R/W:	R/W	R/W	R/W	R/W	R/W	R/W	R/W	R/W

Bits 31 to 0—Break Data Mask Register B31 to B0 (BDMB31 to BDMB0): Specifies bits in the channel B break data bits specified by BDRB (BDB31—BDB0).

Bits 31 to 0:

BDMBn	Description
0	Break data BDBn of channel B is included in the break condition (Initial value)
1	Break data BDBn of channel B is masked and is not included in the break condition

n = 31 to 0

- Notes:
1. Specify an operand size when including the value of the data bus in the break condition.
 2. When a byte size is specified as a break condition, the same-byte data must be set in bits 15 to 8 and bits 7 to 0 in BDRB for the break data.

7.2.8 Break Bus Cycle Register B (BBRB)

Break bus cycle register B (BBRB) is a 16-bit read/write register, which specifies, (1) CPU cycle or DMAC cycle, (2) instruction fetch or data access, (3) read/write, and (4) operand size in the break conditions of channel B. A power-on reset initializes BBRB to H'0000.

Bit:	15	14	13	12	11	10	9	8
	—	—	—	—	—	—	—	—
Initial value:	0	0	0	0	0	0	0	0
R/W:	R	R	R	R	R	R	R	R
Bit:	7	6	5	4	3	2	1	0
	CDB1	CDB0	IDB1	IDB0	RWB1	RWB0	SZB1	SZB0
Initial value:	0	0	0	0	0	0	0	0
R/W:	R/W	R/W	R/W	R/W	R/W	R/W	R/W	R/W

Bits 15 to 8—Reserved: These bits are always read as 0. These bits are always read as 0.

Bits 7 and 6—CPU Cycle/DMAC Cycle Select B (CDB1, CDB0): Select the CPU cycle or DMAC cycle as the bus cycle of the channel B break condition.

Bit 7: CDB1	Bit 6: CDB0	Description
0	0	Condition comparison is not performed (Initial value)
*	1	The break condition is the CPU cycle
1	0	The break condition is the DMAC cycle

*: Don't care

Bits 5 and 4—Instruction Fetch/Data Access Select B (IDB1, IDB0): Select the instruction fetch cycle or data access cycle as the bus cycle of the channel B break condition.

Bit 5: IDB1	Bit 4: IDB0	Description
0	0	Condition comparison is not performed (Initial value)
	1	The break condition is the instruction fetch cycle
1	0	The break condition is the data access cycle
	1	The break condition is the instruction fetch cycle or data access cycle

Bits 3 and 2—Read/Write Select B (RWB1, RWB0): Select the read cycle or write cycle as the bus cycle of the channel B break condition.

Bit 3: RWB1	Bit 2: RWB0	Description
0	0	Condition comparison is not performed (Initial value)
	1	The break condition is the read cycle
1	0	The break condition is the write cycle
	1	The break condition is the read cycle or write cycle

Bits 1 and 0—Operand Size Select B (SZB1, SZB0): Select the operand size of the bus cycle for the channel B break condition.

Bit 1: SZB1	Bit 0: SZB0	Description
0	0	The break condition does not include operand size (Initial value)
	1	The break condition is byte access
1	0	The break condition is word access
	1	The break condition is longword access

7.2.9 Break Control Register (BRCR)

BRCR sets the following conditions:

1. Channels A and B are used in two independent channels condition or under the sequential condition.
2. A break is set before or after instruction execution.
3. A break is set by the number of execution times.
4. Determine whether to include data bus on channel B in comparison conditions.
5. Enable PC trace.
6. Enable the ASID check.

The break control register (BRCR) is a 32-bit read/write register that has break conditions match flags and bits for setting a variety of break conditions. A power-on reset initializes BRCR to H'00000000.

Bit:	31	30	29	28	27	26	25	24
	—	—	—	—	—	—	—	—
Initial value:	0	0	0	0	0	0	0	0
R/W:	R	R	R	R	R	R	R	R
Bit:	23	22	21	20	19	18	17	16
	—	—	BASMA	BASMB	—	—	—	—
Initial value:	0	0	0	0	0	0	0	0
R/W:	R	R	R/W	R/W	R	R	R	R
Bit:	15	14	13	12	11	10	9	8
	SCMFCA	SCMFBCB	SCMFDA	SCMFDB	PCTE	PCBA	—	—
Initial value:	0	0	0	0	0	0	0	0
R/W:	R/W	R/W	R/W	R/W	R/W	R/W	R	R
Bit:	7	6	5	4	3	2	1	0
	DBEB	PCBB	—	—	SEQ	—	—	ETBE
Initial value:	0	0	0	0	0	0	0	0
R/W:	R/W	R/W	R	R	R/W	R	R	R/W

Bits 31 to 22—Reserved: These bits are always read as 0. The write value should always be 0.

Bit 21—Break ASID Mask A (BASMA): Specifies whether the bits of the channel A break ASID7-ASID0 (BASA7 to BASA0) set in BASRA are masked or not.

Bit 21: BASMA Description

0	All BASRA bits are included in break condition, ASID is checked	(Initial value)
1	No BASRA bits are included in break condition, ASID is not checked	

Bit 20—Break ASID Mask B (BASMB): Specifies whether the bits of channel B break ASID7-ASID0 (BASB7 to BASB0) set in BASRB are masked or not.

Bit 20: BASMB Description

0	All BASRB bits are included in break condition, ASID is checked	(Initial value)
1	No BASRB bits are included in break condition, ASID is not checked	

Bits 19 to 16—Reserved: These bits are always read as 0. The write value should always be 0.

Bit 15—CPU Condition Match Flag A (SCMFCA): When the CPU bus cycle condition in the break conditions set for channel A is satisfied, this flag is set to 1 (not cleared to 0). In order to clear this flag, write 0 into this bit.

Bit 15:

SCMFCA	Description	
0	The CPU cycle condition for channel A does not match	(Initial value)
1	The CPU cycle condition for channel A matches	

Bit 14—CPU Condition Match Flag B (SCMF CB): When the CPU bus cycle condition in the break conditions set for channel B is satisfied, this flag is set to 1 (not cleared to 0). In order to clear this flag, write 0 into this bit.

Bit 14:

SCMF CB	Description	
0	The CPU cycle condition for channel B does not match	(Initial value)
1	The CPU cycle condition for channel B matches	

Bit 13—DMAC Condition Match Flag A (SCMFDA): When the on-chip DMAC bus cycle condition in the break conditions set for channel A is satisfied, this flag is set to 1 (not cleared to 0). In order to clear this flag, write 0 into this bit.

Bit 13:

SCMFDA	Description	
0	The DMAC cycle condition for channel A does not match	(Initial value)
1	The DMAC cycle condition for channel A matches	

Bit 12—DMAC Condition Match Flag B (SCMFDB): When the on-chip DMAC bus cycle condition in the break conditions set for channel B is satisfied, this flag is set to 1 (not cleared to 0). In order to clear this flag, write 0 into this bit.

Bit 12:

SCMFDB	Description	
0	The DMAC cycle condition for channel B does not match	(Initial value)
1	The DMAC cycle condition for channel B matches	

Bit 11—PC Trace Enable (PCTE): Enables PC trace.

Bit 11: PCTE **Description**

0	Disables PC trace	(Initial value)
1	Enables PC trace	

Bit 10—PC Break Select A (PCBA): Selects the break timing of the instruction fetch cycle for channel A as before or after instruction execution.

Bit 10: PCBA **Description**

0	PC break of channel A is set before instruction execution	(Initial value)
1	PC break of channel A is set after instruction execution	

Bits 9 and 8—Reserved: These bits are always read as 0. The write value should always be 0.

Bit 7—Data Break Enable B (DBEB): Selects whether or not the data bus condition is included in the break condition of channel B.

Bit 7: DBEB **Description**

0	No data bus condition is included in the condition of channel B	(Initial value)
1	The data bus condition is included in the condition of channel B	

Bit 6—PC Break Select B (PCBB): Selects the break timing of the instruction fetch cycle for channel B as before or after instruction execution.

Bit 6: PCBB	Description
0	PC break of channel B is set before instruction execution (Initial value)
1	PC break of channel B is set after instruction execution

Bits 5 and 4—Reserved: These bits are always read as 0. The write value should always be 0.

Bit 3—Sequence Condition Select (SEQ): Selects two conditions of channels A and B as independent or sequential.

Bit 3: SEQ	Description
0	Channels A and B are compared under the independent condition (Initial value)
1	Channels A and B are compared under the sequential condition (channel A, then channel B)

Bits 2 and 1—Reserved: These bits are always read as 0. The write value should always be 0.

Bit 0—The Number of Execution Times Break Enable (ETBE): Enable the execution-times break condition only on channel B. If this bit is 1 (break enable), a user break is issued when the number of break conditions matches with the number of execution times that is specified by the BETR register.

Bit 0: ETBE	Description
0	The execution-times break condition is masked on channel B (Initial value)
1	The execution-times break condition is enabled on channel B

7.2.10 Execution Times Break Register (BETR)

When the execution-times break condition of channel B is enabled, this register specifies the number of execution times to make the break. The maximum number is $2^{12} - 1$ times. A power-on reset initializes BETR to H'0000. When a break condition is satisfied, it decreases the BETR. A break is issued when the break condition is satisfied after the BETR becomes H'0001. Bits 15-12 are always read as 0 and 0 should always be written in these bits.

Bit:	15	14	13	12	11	10	9	8
	—	—	—	—				
Initial value:	0	0	0	0	0	0	0	0
R/W:	R	R	R	R	R/W	R/W	R/W	R/W

Bit:	7	6	5	4	3	2	1	0
Initial value:	0	0	0	0	0	0	0	0
R/W:	R/W	R/W	R/W	R/W	R/W	R/W	R/W	R/W

7.2.11 Branch Source Register (BRSR)

BRSR is a 32-bit read register. BRSR stores the last fetched address before branch and the pointer (3 bits) which indicates the number of cycles from fetch to execution for the last executed instruction. BRSR has the flag bit that is set to 1 when branch occurs. This flag bit is cleared to 0, when BRSR is read and also initialized by power-on resets or manual resets. Other bits are not initialized by reset. Eight BRSR registers have queue structure and a stored register is shifted every branch.

Bit:	31	30	29	28	27	26	25	24
	SVF	PID2	PID1	PID0	BSA27	BSA26	BSA25	BSA24
Initial value:	0	*	*	*	*	*	*	*
R/W:	R	R	R	R	R	R	R	R
Bit:	23	22	21	20	19	18	17	16
	BSA23	BSA22	BSA21	BSA20	BSA19	BSA18	BSA17	BSA16
Initial value:	*	*	*	*	*	*	*	*
R/W:	R	R	R	R	R	R	R	R
Bit:	15	14	13	12	11	10	9	8
	BSA15	BSA14	BSA13	BSA12	BSA11	BSA10	BSA9	BSA8
Initial value:	*	*	*	*	*	*	*	*
R/W:	R	R	R	R	R	R	R	R
Bit:	7	6	5	4	3	2	1	0
	BSA7	BSA6	BSA5	BSA4	BSA3	BSA2	BSA1	BSA0
Initial value:	*	*	*	*	*	*	*	*
R/W:	R	R	R	R	R	R	R	R

Note: * Undefined value

Bit 31—BRSR Valid Flag (SVF): Indicates whether the address and the pointer by which the branch source address can be calculated. When a branch source address is fetched, this flag is set to 1. This flag is cleared to 0 in reading BRSR.

Bit 31: SVF Description

0	The value of BRSR register is invalid
1	The value of BRSR register is valid

Bits 30 to 28—Instruction Decode Pointer (PID2 to PID0): PID is a 3-bit binary pointer (0–7). These bits indicate the instruction buffer number which stores the last executed instruction before branch.

Bits 30 to 28:

PID	Description
Even	PID indicates the instruction buffer number.
Odd	PiD+2 indicates the instruction buffer number

Bits 27 to 0—Branch Source Address (BSA27 to BSA0): These bits store the last fetched address before branch.

7.2.12 Branch Destination Register (BRDR)

BRDR is a 32-bit read register. BRDR stores the branch destination fetch address. BRDR has the flag bit that is set to 1 when branch occurs. This flag bit is cleared to 0, when BRDR is read and also initialized by power-on resets or manual resets. Other bits are not initialized by resets. Eight BRDR registers have queue structure and a stored register is shifted every branch.

Bit:	31	30	29	28	27	26	25	24
	DVF	—	—	—	BDA27	BDA26	BDA25	BDA24
Initial value:	0	*	*	*	*	*	*	*
R/W:	R	R	R	R	R	R	R	R
Bit:	23	22	21	20	19	18	17	16
	BDA23	BDA22	BDA21	BDA20	BDA19	BDA18	BDA17	BDA16
Initial value:	*	*	*	*	*	*	*	*
R/W:	R	R	R	R	R	R	R	R
Bit:	15	14	13	12	11	10	9	8
	BDA15	BDA14	BDA13	BDA12	BDA11	BDA10	BDA9	BDA8
Initial value:	*	*	*	*	*	*	*	*
R/W:	R	R	R	R	R	R	R	R
Bit:	7	6	5	4	3	2	1	0
	BDA7	BDA6	BDA5	BDA4	BDA3	BDA2	BDA1	BDA0
Initial value:	*	*	*	*	*	*	*	*
R/W:	R	R	R	R	R	R	R	R

Note: * Undefined value

Bit 31—BRDR Valid Flag (DVF): Indicates whether a branch destination address is stored. When a branch destination address is fetched, this flag is set to 1. This flag is set to 0 in reading BRDR.

Bit 31: DVF	Description
0	The value of BRDR register is invalid
1	The value of BRDR register is valid

Bits 30 to 28—Reserved: These bits are always read as 0. The write value should always be 0.

Bits 27 to 0—Branch Destination Address (BDA27 to BDA0): These bits store the first fetched address after branch.

7.2.13 Break ASID Register A (BASRA)

Break ASID register A (BASRA) is an 8-bit read/write register that specifies the ASID that serves as the break condition for channel A. It is not initialized by resets.

Bit:	7	6	5	4	3	2	1	0
	BASA7	BASA6	BASA5	BASA4	BASA3	BASA2	BASA1	BASA0
Initial value:	*	*	*	*	*	*	*	*
R/W:	R/W	R/W	R/W	R/W	R/W	R/W	R/W	R/W

Note: * Undefined value

Bits 7 to 0—Break ASID A7 to 0 (BASA7 to BASA0): These bits store the ASID (bits 7 to 0) that is the channel A break condition.

7.2.14 Break ASID Register B (BASRB)

Break ASID register B (BASRB) is an 8-bit read/write register that specifies the ASID that serves as the break condition for channel B. It is not initialized by resets.

Bit:	7	6	5	4	3	2	1	0
	BASB7	BASB6	BASB5	BASB4	BASB3	BASB2	BASB1	BASB0
Initial value:	*	*	*	*	*	*	*	*
R/W:	R/W	R/W	R/W	R/W	R/W	R/W	R/W	R/W

Note: * Undefined value

Bits 7 to 0—Break ASID A7 to 0 (BASB7 to BASB0): These bits store the ASID (bits 7 to 0) that is the channel B break condition.

7.3 Operation Description

7.3.1 Flow of the User Break Operation

The flow from setting of break conditions to user break exception processing is described below:

1. The break addresses and the corresponding ASIDs are loaded in the break address registers (BARA and BARB) and break ASID registers (BASRA and BASRB). The masked addresses are set in the break address mask registers (BAMRA and BAMRB). The break data is set in the break data register (BDRB). The masked data is set in the break data mask register (BDMRB). The breaking bus conditions are set in the break bus cycle registers (BBRA and BBRB). Three groups of the BBRA and BBRB (CPU cycle/DMAC cycle select, instruction fetch/data access select, and read/write select) are each set. No user break will be generated if even one of these groups is set with 00. The respective conditions are set in the bits of the BRCCR.
2. When the break conditions are satisfied, the UBC sends a user break request to the interrupt controller. The break type will be sent to CPU indicating the instruction fetch, pre/post instruction break, data access break. When conditions match up, the CPU condition match flags (SCMFCA and SCMFCE) and DMAC condition match flags (SCMFDA and SCMFDE) for the respective channels are set.
3. The appropriate condition match flags (SCMFCA, SCMFDA, SCMFCE, and SCMFDE) can be used to check if the set conditions match or not. The matching of the conditions sets flags, but they are not reset. 0 must first be written to them before they can be used again.
4. There is a chance that the data access break and its following instruction fetch break occur around the same time, there will be only one break request to the CPU, but these two break channel match flags could be both set.

7.3.2 Break on Instruction Fetch Cycle

1. When CPU/instruction fetch/read/word or longword is set in the break bus cycle registers (BBRA/BBRB), the break condition becomes the CPU instruction fetch cycle. Whether it then breaks before or after the execution of the instruction can then be selected with the PCBA/PCBB bits of the break control register (BRCCR) for the appropriate channel.
2. An instruction set for a break before execution breaks when it is confirmed that the instruction has been fetched and will be executed. This means this feature cannot be used on instructions fetched by overrun (instructions fetched at a branch or during an interrupt transition, but not to be executed). When this kind of break is set for the delay slot of a delay branch instruction, the break is generated prior to execution of the instruction that then first accepts the break. Meanwhile, the break set for pre-instruction-break on delay slot instruction and post-instruction-break on SLEEP instruction are also prohibited.

3. When the condition is specified to be occurred after execution, the instruction set with the break condition is executed and then the break is generated prior to the execution of the next instruction. As with pre-execution breaks, this cannot be used with overrun fetch instructions. When this kind of break is set for a delay branch instruction, the break is generated at the instruction that then first accepts the break.
4. When an instruction fetch cycle is set for channel B, break data register B (BDRB) is ignored. There is thus no need to set break data for the break of the instruction fetch cycle.

7.3.3 Break by Data Access Cycle

1. The memory cycles in which CPU data access breaks occur are from instructions.
2. The relationship between the data access cycle address and the comparison condition for operand size are listed in table 7.2:

Table 7.2 Data Access Cycle Addresses and Operand Size Comparison Conditions

Access Size	Address Compared
Longword	Compares break address register bits 31–2 to address bus bits 31–2
Word	Compares break address register bits 31–1 to address bus bits 31–1
Byte	Compares break address register bits 31–0 to address bus bits 31–0

This means that when address H'00001003 is set without specifying the size condition, for example, the bus cycle in which the break condition is satisfied is as follows (where other conditions are met).

Longword access at H'00001000

Word access at H'00001002

Byte access at H'00001003

3. When the data value is included in the break conditions on B channel:

When the data value is included in the break conditions, either longword, word, or byte is specified as the operand size of the break bus cycle registers (BBRA and BBRB). When data values are included in break conditions, a break is generated when the address conditions and data conditions both match. To specify byte data for this case, set the same data in two bytes at bits 15–8 and bits 7–0 of the break data register B (BDRB) and break data mask register B (BDMRB). When word or byte is set, bits 31–16 of BDRB and BDMRB are ignored.
4. When the DMAC data access is included in the break condition:

When the address is included in the break condition on DMAC data access, the operand size of the break bus cycle registers (BBRA and BBRB) should be byte, word or no specified operand size. When the data value is included, select either byte or word.

7.3.4 Sequential Break

1. By specifying SEQ in BRCR is set to 1, the sequential break is issued when channel B break condition matches after channel A break condition matches. A user break is ignored even if channel B break condition matches before channel A break condition matches. When channels A and B condition match at the same time, the sequential break is not issued.
2. In sequential break specification, a logical bus or internal bus can be selected and the execution times break condition can be also specified. For example, when the execution times break condition is specified, the break condition is satisfied at channel B condition match with BETR = H'0001 after channel A condition match.

7.3.5 Value of Saved Program Counter

The PC when a break occurs is saved to the SPC in user breaks. The PC value saved is as follows depending on the type of break.

1. When instruction fetch (before instruction execution) is specified as a break condition:
The value of the program counter (PC) saved is the address of the instruction that matches the break condition. The fetched instruction is not executed, and a break occurs before it.
2. When instruction fetch (after instruction execution) is specified as a break condition:
The PC value saved is the address of the instruction to be executed following the instruction in which the break condition matches. The fetched instruction is executed, and a break occurs before the execution of the next instruction.
3. When data access (address only) is specified as a break condition:
The PC value is the address of the instruction to be executed following the instruction that matched the break condition. The instruction that matched the condition is executed and the break occurs before the next instruction is executed.
4. When data access (address + data) is specified as a break condition:
The PC value is the start address of the instruction that follows the instruction already executed when break processing started up. When a data value is added to the break conditions, the place where the break will occur cannot be specified exactly. The break will occur before the execution of an instruction fetched around the data access where the break occurred.

7.3.6 PC Trace

1. Setting PCTE in BRCCR to 1 enables PC traces. When branch (branch instruction, repeat, and interrupt) is generated, the address from which the branch source address can be calculated and the branch destination address are stored in BRSR and BRDR, respectively. The branch address and the pointer, which corresponds to the branch, are included in BRSR.
2. The branch address before branch occurs can be calculated from the address and the pointer stored in BRSR. The expression from BSA (the address in BRSR), PID (the pointer in BRSR), and IA (the instruction address before branch occurs) is as follows: $IA = BSA - 2 * PID$.

Notes are needed when an interrupt (a branch) is issued before the branch destination instruction is executed. In case of the next figure, the instruction “Exec” executed immediately before branch is calculated by $IA = BSA - 2 * PID$. However, when branch “branch” has delay slot and the destination address is $4n + 2$ address, the address “Dest” which is specified by branch instruction is stored in BRSR ($Dest = BSA$). Therefore, as $IA = BSA - 2 * PID$ is not applied to this case, this PID is invalid. The case where BSA is $4n + 2$ boundary is applied only to this case and then some cases are classified as follows:

```
Exec:branch  Dest
Dest:instr    (not executed)
           interrupt
Int: interrupt routine
```

If the PID value is odd, instruction buffer indicates PID+2 buffer. However, these expressions in this table are accounted for it. Therefore, the true branch source address is calculated with BSA and PID values stored in BRSR.

3. The branch address before branch occurrence, IA, has different values due to some kinds of branch.
 - a. Branch instruction
The branch instruction address
 - b. Interrupt
The last instruction executed before interrupt
The top address of interrupt routine is stored in BRDR.
4. BRSR and BRDR have eight pairs of queue structures. The top of queues is read first when the address stored in the PC trace register is read. BRSR and BRDR share the read pointer. Read BRSR and BRDR in order, the queue only shifts after BRDR is read. When reading BRDR, longword access should be used. Also, the PC trace has a trace pointer, which initially points to the bottom of the queues. The first pair of branch addresses will be stored at the bottom of the queues, then push up when next pairs come into the queues. The trace pointer will points to the next branch address to be executed, unless it got push out of the queues. When the branch address has been executed, the trace pointer will shift down to next pair of addresses, until it

reaches the bottom of the queues. After switching the PCTE bit (in BRCCR) off and on, the values in the queues are invalid. The read pointer stay at the position before PCTE is switched, but the trace pointer restart at the bottom of the queues.

7.3.7 Usage Examples

Break Condition Specified to a CPU Instruction Fetch Cycle

1. Register specifications

BARA = H'00000404, BAMRA = H'00000000, BBRA = H'0054, BARB = H'00008010, BAMRB = H'00000006, BBRB = H'0054, BDRB = H'00000000, BDMRB = H'00000000, BRCCR = H'00300400

Specified conditions: Channel A/channel B independent mode

- Channel A

Address: H'00000404, Address mask: H'00000000

Bus cycle: CPU/instruction fetch (after instruction execution)/read (operand size is not included in the condition)

No ASID check is included

- Channel B

Address: H'00008010, Address mask: H'00000006

Data: H'00000000, Data mask: H'00000000

Bus cycle: CPU/instruction fetch (before instruction execution)/read (operand size is not included in the condition)

No ASID check is included

A user break occurs after an instruction of address H'00000404 is executed or before instructions of addresses H'00008010 to H'00008016 are executed.

2. Register specifications

BARA = H'00037226, BAMRA = H'00000000, BBRA = H'0056, BARB = H'0003722E,
BAMRB = H'00000000, BBRB = H'0056, BDRB = H'00000000, BDMRB = H'00000000,
BRCR = H'00000008, BASRA = H'80, BASRB = H'70

Specified conditions: Channel A/channel B sequence mode

- Channel A

Address: H'00037226, Address mask: H'00000000, ASID = H'80

Bus cycle: CPU/instruction fetch (before instruction execution)/read/word

- Channel B

Address: H'0003722E, Address mask: H'00000000, ASID = H'70

Data: H'00000000, Data mask: H'00000000

Bus cycle: CPU/instruction fetch (before instruction execution)/read/word

An instruction with ASID = H'80 and address H'00037226 is executed, and a user break occurs before an instruction with ASID = H'70 and address H'0003722E is executed.

3. Register specifications

BARA = H'00027128, BAMRA = H'00000000, BBRA = H'005A, BARB = H'00031415,
BAMRB = H'00000000, BBRB = H'0054, BDRB = H'00000000, BDMRB = H'00000000,
BRCR = H'00300000

Specified conditions: Channel A/channel B independent mode

- Channel A

Address: H'00027128, Address mask: H'00000000

Bus cycle: CPU/instruction fetch (before instruction execution)/write/word

No ASID check is included

- Channel B

Address: H'00031415, Address mask: H'00000000

Data: H'00000000, Data mask: H'00000000

Bus cycle: CPU/instruction fetch (before instruction execution)/read (operand size is not included in the condition)

No ASID check is included

On channel A, no user break occurs since instruction fetch is not a write cycle. On channel B, no user break occurs since instruction fetch is performed for an even address.

4. Register specifications

BARA = H'00037226, BAMRA = H'00000000, BBRA = H'005A, BARB = H'0003722E,
BAMRB = H'00000000, BBRB = H'0056, BDRB = H'00000000, BDMRB = H'00000000,
BRCR = H'00000008, BASRA = H'80, BASRB = H'70

Specified conditions: Channel A/channel B sequence mode

- Channel A

Address: H'00037226, Address mask: H'00000000, ASID: H'80

Bus cycle: CPU/instruction fetch (before instruction execution)/write/word

- Channel B

Address: H'0003722E, Address mask: H'00000000, ASID: H'70

Data: H'00000000, Data mask: H'00000000

Bus cycle: CPU/instruction fetch (before instruction execution)/read/word

Since instruction fetch is not a write cycle on channel A, a sequence condition does not match. Therefore, no user break occurs.

5. Register specifications

BARA = H'00000500, BAMRA = H'00000000, BBRA = H'0057, BARB = H'00001000,
BAMRB = H'00000000, BBRB = H'0057, BDRB = H'00000000, BDMRB = H'00000000,
BRCR = H'00300001, BETR = H'0005

Specified conditions: Channel A/channel B independent mode

- Channel A

Address: H'00000500, Address mask: H'00000000

Bus cycle: CPU/instruction fetch (before instruction execution)/read/longword

- Channel B

Address: H'00001000, Address mask: H'00000000

Data: H'00000000, Data mask: H'00000000

Bus cycle: CPU/instruction fetch (before instruction execution)/read/longword

The number of execution-times break enable (5 times)

On channel A, a user break occurs before an instruction of address H'00000500 is executed. On channel B, a user break occurs before the fifth instruction execution after instructions of address H'00001000 are executed four times.

6. Register specifications

BARA = H'00008404, BAMRA = H'00000FFF, BBRA = H'0054, BARB = H'00008010, BAMRB = H'00000006, BBRB = H'0054, BDRB = H'00000000, BDMRB = H'00000000, BR CR = H'00000400, BASRA = H'80, BASRB = H'70

Specified conditions: Channel A/channel B independent mode

- Channel A

Address: H'00008404, Address mask: H'00000FFF, ASID: H'80

Bus cycle: CPU/instruction fetch (after instruction execution)/read (operand size is not included in the condition)

- Channel B

Address: H'00008010, Address mask: H'00000006, ASID: H'70

Data: H'00000000, Data mask: H'00000000

Bus cycle: CPU/instruction fetch (before instruction execution)/read (operand size is not included in the condition)

A user break occurs after an instruction with ASID = H'80 and address H'00008000 to H'00008FFE is executed or before instructions with ASID = H'70 and addresses H'00008010 to H'00008016 are executed.

Break Condition Specified to a CPU Data Access Cycle

1. Register specifications

BARA = H'00123456, BAMRA = H'00000000, BBRA = H'0064, BARB = H'000ABCDE, BAMRB = H'000000FF, BBRB = H'006A, BDRB = H'0000A512, BDMRB = H'00000000, BR CR = H'00000080, BASRA = H'80, BASRB = H'70

Specified conditions: Channel A/channel B independent mode

- Channel A

Address: H'00123456, Address mask: H'00000000

Bus cycle: CPU/data access/read (operand size is not included in the condition)

- Channel B

Address: H'000ABCDE, Address mask: H'000000FF, ASID: H'70

Data: H'0000A512, Data mask: H'00000000

Bus cycle: CPU/data access/write/word

On channel A, a user break occurs with ASID = H'80 during longword read to address H'00123454, word read to address H'00123456, or byte read to address H'00123456. On channel B, a user break occurs with ASID = H'70 when word H'A512 is written in addresses H'000ABC00 to H'000ABCFE.

Break Condition Specified to a DMAC Data Access Cycle

1. Register specifications:

BARA = H'00314156, BAMRA = H'00000000, BBRA = H'0094, BARB = H'00055555,
BAMRB = H'00000000, BBRB = H'00A9, BDRB = H'00000078, BDMRB = H'0000000F,
BRCR = H'00000080, BASRA = H'80, BASRB = H'70

Specified conditions: Channel A/channel B independent mode

- Channel A

Address: H'00314156, Address mask: H'00000000, ASID: H'80

Bus cycle: DMAC/instruction fetch/read (operand size is not included in the condition)

- Channel B

Address: H'00055555, Address mask: H'00000000, ASID: H'70

Data: H'00000078, Data mask: H'0000000F

Bus cycle: DMAC/data access/write/byte

On channel A, no user break occurs since instruction fetch is not performed in DMAC cycles.
On channel B, a user break occurs with ASID = H'70 when the DMAC writes byte H'7* in
address H'00055555.

7.3.8 Notes

1. Only CPU can read/write UBC registers.
2. UBC cannot monitor CPU and DMAC access in the same channel.
3. Notes in specification of sequential break are described below:
 - a. A condition match occurs when B-channel match occurs in a bus cycle after an A-channel match occurs in another bus cycle in sequential break setting. Therefore, no condition match occurs even if a bus cycle, in which an A-channel match and a channel B match occur simultaneously, is set.
 - b. Since the CPU has a pipeline configuration, the pipeline determines the order of an instruction fetch cycle and a memory cycle. Therefore, when a channel condition matches in the order of bus cycles, a sequential condition is satisfied.
 - c. When the bus cycle condition for channel A is specified as a break before execution (PCBA = 0 in BRRCR) and an instruction fetch cycle (in BBRA), the attention is as follows. A break is issued and condition match flags in BRRCR are set to 1, when the bus cycle conditions both for channels A and B match simultaneously.
4. The change of a UBC register value is executed in MA (memory access) stage. Therefore, even if the break condition matches in the instruction fetch address following the instruction in which the pre-execution break is specified as the break condition, no break occurs. In order to know the timing UBC register is changed, read the last written register. Instructions after then are valid for the newly written register value.
5. The branch instruction should not be executed as soon as PC trace register BRSR and BRDR are read.
6. When PC breaks and TLB exceptions or errors occur in the same instruction. The priority is as follows:
 - a. Break and instruction fetch exceptions: Instruction fetch exception occurs first.
 - b. Break before execution and operand exception: Break before execution occurs first.
 - c. Break after execution and operand exception: Operand exception occurs first.

Section 8 Power-Down Modes

8.1 Overview

In the power-down modes, all CPU and some on-chip peripheral module functions are halted. This lowers power consumption.

8.1.1 Power-Down Modes

The SH7709S has the following power-down modes and function:

1. Sleep mode
2. Standby mode
3. Module standby function (TMU, RTC, SCI, UBC, DMAC, DAC, ADC, SCIF, and IrDA on-chip peripheral modules)
4. Hardware standby mode

Table 8.1 shows the transition conditions for entering the modes from the program execution state, as well as the CPU and peripheral module states in each mode and the procedures for canceling each mode.

Table 8.1 Power-Down Modes

Mode	Transition Conditions	State							
		CPG	CPU	CPU Register	On-Chip Memory	On-Chip Peripheral Modules	Pins	External Memory	Canceling Procedure
Sleep mode	Execute SLEEP instruction with STBY bit cleared to 0 in STBCR	Runs	Halts	Held	Held	Run	Held	Refresh	1. Interrupt 2. Reset
Standby mode	Execute SLEEP instruction with STBY bit set to 1 in STBCR	Halts	Halts	Held	Held	Halt ^{*1}	Held	Self-refresh	1. Interrupt 2. Reset
Module standby function	Set MSTP bit to 1 in STBCR	Runs	Runs or halts	Held	Held	Specified module halts	^{*2}	Refresh	1. Clear MSTP bit to 0 2. Reset
Hardware standby mode	Drive CA pin low	Halts	Halts	Held	Held	Halt ^{*3}	Held	Self-refresh	Power-on reset

Notes: 1. The RTC still runs if the START bit in RCR2 is set to 1 (see section 13, Realtime Clock (RTC)). The TMU still runs when output of the RTC is used as input to its counter (see section 12, Timer (TMU)).

2. Depends on the on-chip peripheral module.

TMU external pin: Held

SCI external pin: Reset

3. The RTC still runs if the START bit in RCR2 is set to 1. The TMU does not run.

8.1.2 Pin Configuration

Table 8.2 lists the pins used for the power-down modes.

Table 8.2 Pin Configuration

Pin Name	Abbreviation	I/O	Description
Processing state 1	STATUS1	O	Operating state of the processor.
Processing state 0	STATUS0		HH: Reset, HL: Sleep mode, LH: Standby mode, LL: Normal operation
Wakeup from standby mode	WAKEUP	O	Active-low assertion after accepting wakeup interrupt in standby mode until returning to normal operation with WDT overflow

Note: H: high level; L: low level

8.1.3 Register Configuration

Table 8.3 shows the control register configuration for the power-down modes.

Table 8.3 Register Configuration

Name	Abbreviation	R/W	Initial Value	Access Size	Address
Standby control register	STBCR	R/W	H'00*	H'FFFFFF82	8
Standby control register 2	STBCR2	R/W	H'00*	H'FFFFFF88	8

Note: * Initialized by a power-on reset. This value is not initialized by a manual reset; the current value is retained.

8.2 Register Descriptions

8.2.1 Standby Control Register (STBCR)

The standby control register (STBCR) is an 8-bit readable/writable register that sets the power-down mode. STBCR is initialized to H'00 by a power-on reset.

Bit:	7	6	5	4	3	2	1	0
	STBY	—	—	STBXTL	—	MSTP2	MSTP1	MSTP0
Initial value:	0	0	0	0	0	0	0	0
R/W:	R/W	R	R	R/W	R	R/W	R/W	R/W

Bit 7—Standby (STBY): Specifies transition to standby mode.

Bit 7: STBY	Description
0	Executing SLEEP instruction puts chip into sleep mode (Initial value)
1	Executing SLEEP instruction puts chip into standby mode

Bits 6, 5, and 3—Reserved: These bits are always read as 0. The write value should always be 0.

Bit 4—Standby Crystal (STBXTL): Specifies halting or operating of the clock pulse generator in standby mode.

Bit 4: STBXTL	Description
0	Clock pulse generator is halted in standby mode (Initial value)
1	Clock pulse generator is operates in standby mode

Bit 2—Module Standby 2 (MSTP2): Specifies halting of the clock supply to the timer unit TMU (an on-chip peripheral module). When the MSTP2 bit is set to 1, the supply of the clock to the TMU is halted.

Bit 2: MSTP2	Description
0	TMU runs (Initial value)
1	Clock supply to TMU is halted

Bit 1—Module Standby 1 (MSTP1): Specifies halting of the clock supply to the realtime clock RTC (an on-chip peripheral module). When the MSTP1 bit is set to 1, the supply of the clock to the RTC is halted. When the clock halts, all RTC registers become inaccessible, but the counter keeps running.

Bit 1: MSTP1	Description
0	RTC runs (Initial value)
1	Clock supply to RTC is halted

Before switching the RTC to module standby, access at least one among the registers RTC, SCI, and TMU.

Bit 0—Module Standby 0 (MSTP0): Specifies halting of the clock supply to the serial communication interface SCI (an on-chip peripheral module). When the MSTP0 bit is set to 1, the supply of the clock to the SCI is halted.

Bit 0: MSTP0	Description
0	SCI operates (Initial value)
1	Clock supply to SCI is halted

8.2.2 Standby Control Register 2 (STBCR2)

The standby control register 2 (STBCR2) is a readable/writable 8-bit register that sets the power-down mode. STBCR2 is initialized to H'00 by a power-on reset.

Bit:	7	6	5	4	3	2	1	0
	—	MDCHG	MSTP8	MSTP7	MSTP6	MSTP5	MSTP4	MSTP3
Initial value:	0	0	0	0	0	0	0	0
R/W:	R/W	R/W	R/W	R/W	R/W	R/W	R/W	R/W

Bit 7—Reserved: The write value set in the program should always be 1.

Bit 6—Pin MD5 to MD0 Control (MDCHG): Specifies whether or not pins MD5 to MD0 are changed in standby mode. When this bit is set to 1, the MD5 to MD0 pin values are latched when returning from standby mode by means of a reset or interrupt.

Bit 6: MDCHG	Description
0	Pins MD5 to MD0 are not changed in standby mode (Initial value)
1	Pins MD5 to MD0 are changed in standby mode

Bit 5—Module Stop 8 (MSTP8): Specifies halting of the clock supply to the user break controller UBC (an on-chip peripheral module). When the MSTP8 bit is set to 1, the supply of the clock to the UBC is halted.

Bit 5: MSTP8	Description
0	UBC runs (Initial value)
1	Clock supply to UBC is halted

Bit 4—Module Stop 7 (MSTP7): Specifies halting of the clock supply to the DMAC (an on-chip peripheral module). When the MSTP7 bit is set to 1, the supply of the clock to the DMAC is halted.

Bit 4: MSTP7	Description
0	DMAC runs (Initial value)
1	Clock supply to DMAC halted

Bit 3—Module Stop 6 (MSTP6): Specifies halting of the clock supply to the DAC (an on-chip peripheral module). When the MSTP6 bit is set to 1, the supply of the clock to the DAC is halted.

Bit 3: MSTP6	Description
0	DAC runs (Initial value)
1	Clock supply to DAC halted

Bit 2—Module Stop 5 (MSTP5): Specifies halting of the clock supply to the ADC (an on-chip peripheral module). When the MSTP5 bit is set to 1, the supply of the clock to the ADC is halted and all registers are initialized.

Bit 2: MSTP5	Description
0	ADC runs (Initial value)
1	Clock supply to ADC halted and all registers initialized

Bit 1—Module Stop 4 (MSTP4): Specifies halting of the clock supply to the SCI2 (SCIF) serial communication interface with FIFO (an on-chip peripheral module). When the MSTP1 bit is set to 1, the supply of the clock to SCI2 (SCIF) is halted.

Bit 1: MSTP4	Description
0	SCI2 (SCIF) runs (Initial value)
1	Clock supply to SCI2 (SCIF) halted

Bit 0—Module Stop 3 (MSTP3): Specifies halting of the clock supply to the SCI1 (IrDA) Infrared Data Association interface with FIFO (an on-chip peripheral module). When the MSTP3 bit is set to 1, the supply of the clock to SCI1 (IrDA) is halted.

Bit 0: MSTP3	Description
0	SCI1(IrDA) runs (Initial value)
1	Clock supply to SCI1(IrDA) halted

8.3 Sleep Mode

8.3.1 Transition to Sleep Mode

Executing the SLEEP instruction when the STBY bit in STBCR is 0 causes a transition from the program execution state to sleep mode. Although the CPU halts immediately after executing the SLEEP instruction, the contents of its internal registers remain unchanged. The on-chip peripheral modules continue to run in sleep mode and the clock continues to be output to the CKIO and CKIO2 pins. In sleep mode, the STATUS1 pin is set high and the STATUS0 pin low.

8.3.2 Canceling Sleep Mode

Sleep mode is canceled by an interrupt (NMI, IRQ, IRL, on-chip peripheral module, PINT) or reset. Interrupts are accepted in sleep mode even when the BL bit in the SR register is 1. If necessary, save SPC and SSR to the stack before executing the SLEEP instruction.

Canceling with an Interrupt: When an NMI, IRQ, IRL or on-chip peripheral module interrupt occurs, sleep mode is canceled and interrupt exception handling is executed. A code indicating the interrupt source is set in the INTEVT and INTEVT2 registers.

Canceling with a Reset: Sleep mode is canceled by a power-on reset or a manual reset.

8.3.3 Precautions when Using the Sleep Mode

DMAC transfers should not be performed in the sleep mode under conditions other than when the clock ratio of I ϕ (on-chip clock) to B ϕ (bus clock) is 1:1.

8.4 Standby Mode

8.4.1 Transition to Standby Mode

To enter standby mode, set the STBY bit to 1 in STBCR, then execute the SLEEP instruction. The chip switches from the program execution state to standby mode. In standby mode, power consumption is greatly reduced by halting not only the CPU, but the clock and on-chip peripheral modules as well. The clock output from the CKIO and CKIO2 pins also halts. CPU and cache register contents are held, but some on-chip peripheral modules are initialized. Table 8.4 lists the states of registers in standby mode.

Table 8.4 Register States in Standby Mode

Module	Registers Initialized	Registers Retaining Data
Interrupt controller (INTC)	—	All registers
On-chip clock pulse generator (OSC)	—	All registers
User break controller (UBC)	—	All registers
Bus state controller (BSC)	—	All registers
Timer unit (TMU)	TSTR register	Registers other than TSTR
Realtime clock (RTC)	—	All registers
A/D converter (ADC)	All registers	—
D/A converter (DAC)	—	All registers

The procedure for moving to standby mode is as follows:

1. Clear the TME bit in the WDT's timer control register (WTCSR) to 0 to stop the WDT. Clear the WDT's timer counter (WTCNT) to 0 and the CKS2–CKS0 bits in the WTCSR register to appropriate values to secure the specified oscillation settling time.
2. After the STBY bit in the STBCR register is set to 1, a SLEEP instruction is executed.
3. Standby mode is entered and the clocks within the chip are halted. The STATUS1 pin output goes low and the STATUS0 pin output goes high.

8.4.2 Canceling Standby Mode

Standby mode is canceled by an interrupt (NMI, IRQ, IRL, PINT, or on-chip peripheral module) or a reset.

Canceling with an Interrupt: The on-chip WDT can be used for hot starts. When the chip detects an NMI, IRL, IRQ, PINT^{*1}, or on-chip peripheral module (except interval timer)^{*2} interrupt, the clock will be supplied to the entire chip and standby mode canceled after the time set in the WDT's timer control/status register has elapsed. The STATUS1 and STATUS0 pins both go low. Interrupt handling then begins and a code indicating the interrupt source is set in the INTEVT and INTEVT2 registers. After the branch to the interrupt handling routine, clear the STBY bit in the STBCR register. WTCNT stops automatically. If the STBY bit is not cleared, WTCNT continues operation and a transition is made to standby mode^{*3} when it reaches H'80. This function prevents the data from being destroyed due to a rise in voltage with an unstable power supply, etc. Interrupts are accepted in standby mode even when the BL bit in the SR register is 1. If necessary, save SPC and SSR to the stack before executing the SLEEP instruction. Immediately after an interrupt is detected, the phase of the CKIO pin clock output may be unstable, until the processor starts interrupt handling. (The canceling condition is that the IRL3–IRL0 level is higher than the mask level in the I3–I0 bits in the SR register.)

- Notes: 1. When the RTC is being used, standby mode can be canceled using IRL3–IRL0, IRQ4–IRQ0, or PINT0/1.
2. Standby mode can be canceled with an RTC or TMU (only when running on the RTC clock) interrupt.
3. This standby mode can be canceled only by a power-on reset.

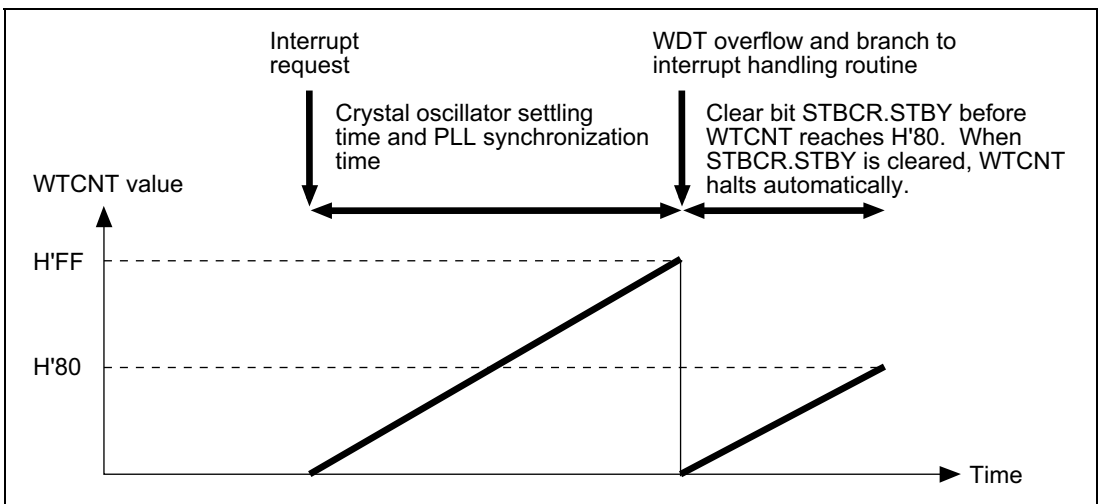

Figure 8.1 Canceling Standby Mode with STBCR.STBY

Canceling with a Reset: Standby mode is canceled by a reset (power-on or manual). Keep the $\overline{\text{RESET}}$ pin low until the clock oscillation settles. The internal clock will continue to be output to the CKIO and CKIO2 pins.

8.4.3 Clock Pause Function

In standby mode, the clock input from the EXTAL pin or CKIO pin can be halted and the frequency can be changed. This function is used as follows:

1. Enter standby mode using the appropriate procedures.
2. Once standby mode is entered and the clock stopped within the chip, the STATUS1 pin output is low and the STATUS0 pin output is high.
3. Once the STATUS1 pin goes low and the STATUS0 pin goes high, the input clock is stopped or the frequency is changed.
4. When the frequency is changed, an NMI, IRL, IRQ, PINT, or on-chip peripheral module (except interval timer) interrupt is input after the change. When the clock is stopped, the same interrupts are input after the clock is applied.
5. After the time set in the WDT has elapsed, the clock starts being applied internally within the chip, the STATUS1 and STATUS0 pins both go low, and operation resumes from interrupt exception handling.

8.5 Module Standby Function

8.5.1 Transition to Module Standby Function

Setting the standby control register MSTP8–MSTP0 bits to 1 halts the supply of clocks to the corresponding on-chip peripheral modules. This function can be used to reduce the power consumption in normal mode and sleep mode. The module standby function holds the state prior to halting the external pins of the on-chip peripheral modules. TMU external pins hold their state prior to the halt. SCI external pins go to the reset state. With a few exceptions, all registers hold their values.

Bit	Value	Description
MSTP8	0	UBC runs
	1	Supply of clock to UBC halted
MSTP7	0	DMAC runs
	1	Supply of clock to DMAC halted
MSTP6	0	DAC runs
	1	Supply of clock to DAC halted
MSTP5	0	ADC runs
	1	Supply of clock to ADC halted, and all registers initialized
MSTP4	0	SCIF runs
	1	Supply of clock to SCIF halted
MSTP3	0	IrDA runs
	1	Supply of clock to IrDA halted
MSTP2	0	TMU runs
	1	Supply of clock to TMU halted. Registers initialized*1
MSTP1	0	RTC runs
	1	Supply of clock to RTC halted. Register access prohibited*2*3
MSTP0	0	SCI runs
	1	Supply of clock to SCI halted

Notes: 1. The registers initialized are the same as in standby mode (see table 8.4).
2. The counter runs.
3. Before switching the RTC to module standby, access at least one among the registers RTC, SCI, and TMU.

8.5.2 Clearing Module Standby Function

The module standby function can be cleared by clearing the MSTPSLP0 and MSTP8–MSTP0 bits to 0, or by a power-on reset or manual reset.

8.6 Timing of STATUS Pin Changes

The timing of STATUS1 and STATUS0 pin changes is shown in figures 8.1 to 8.8.

8.6.1 Timing for Resets

Power-On Reset

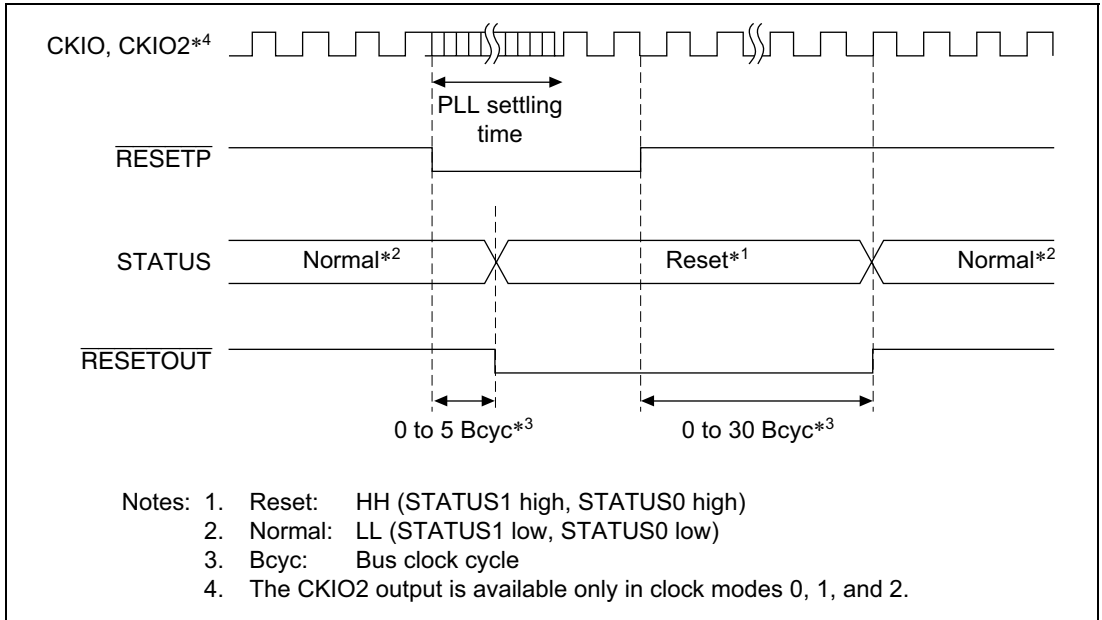

Figure 8.2 Power-On Reset (Clock Modes 0, 1, 2, and 7) STATUS Output

Manual Reset

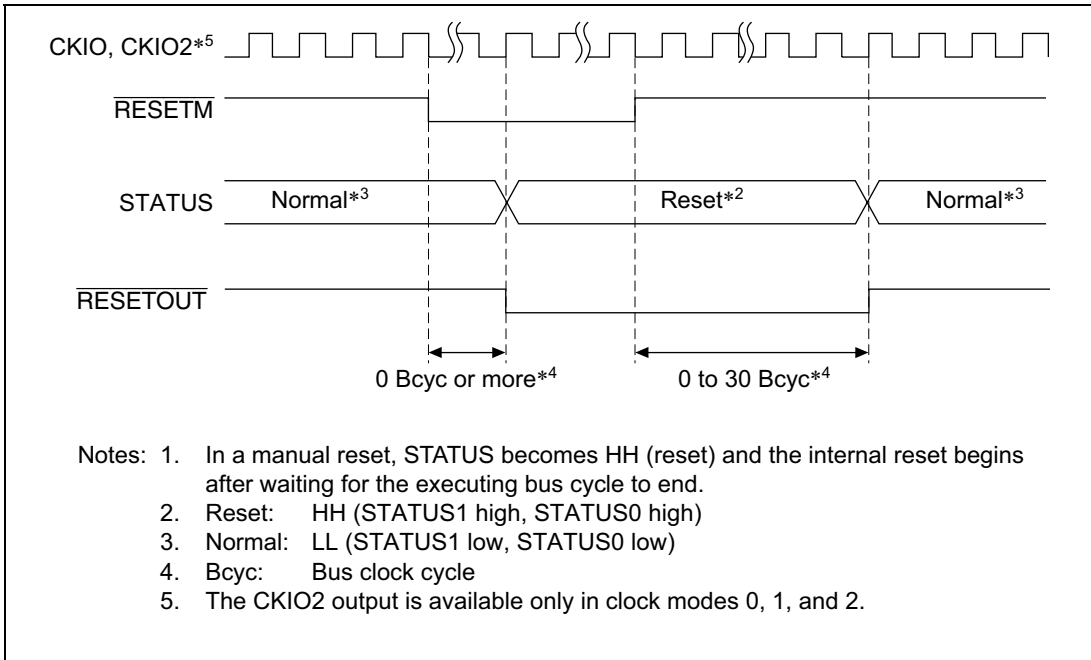

Figure 8.3 Manual Reset STATUS Output

8.6.2 Timing for Canceling Standby

Standby to Interrupt

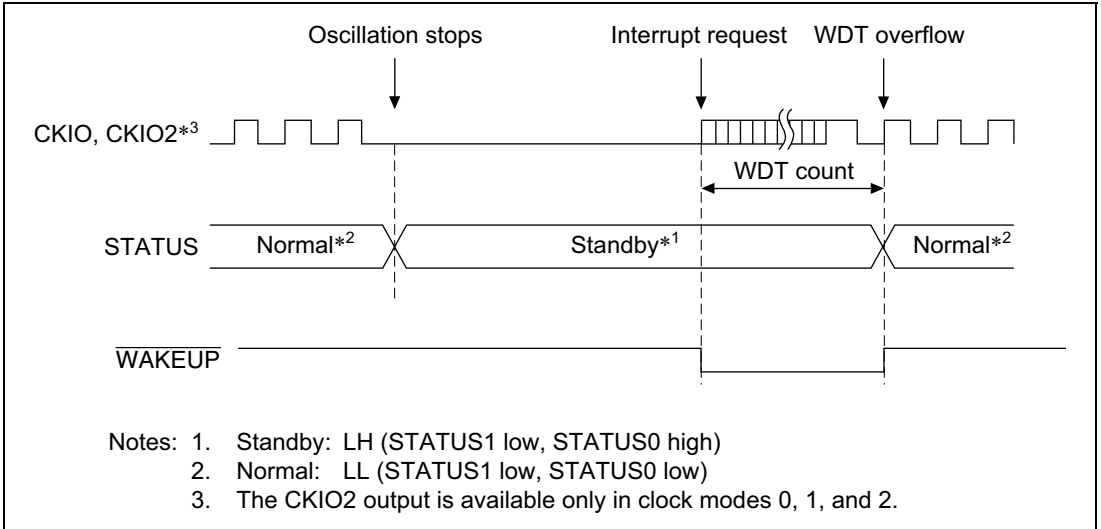

Figure 8.4 Standby to Interrupt STATUS Output

Standby to Power-On Reset

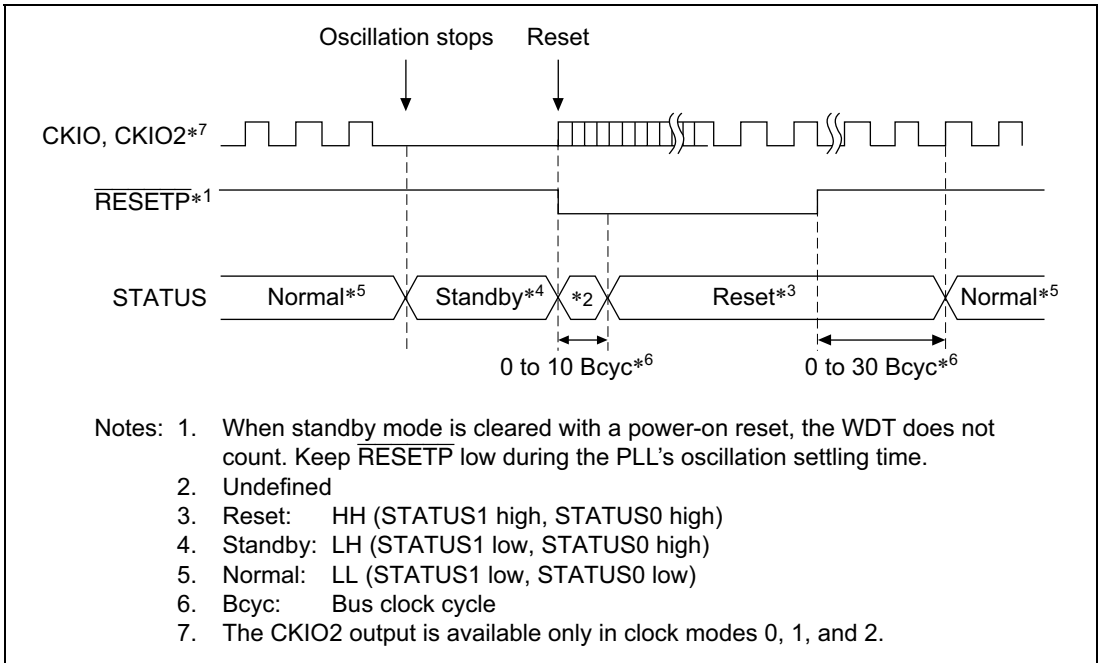

Figure 8.5 Standby to Power-On Reset STATUS Output

Standby to Manual Reset

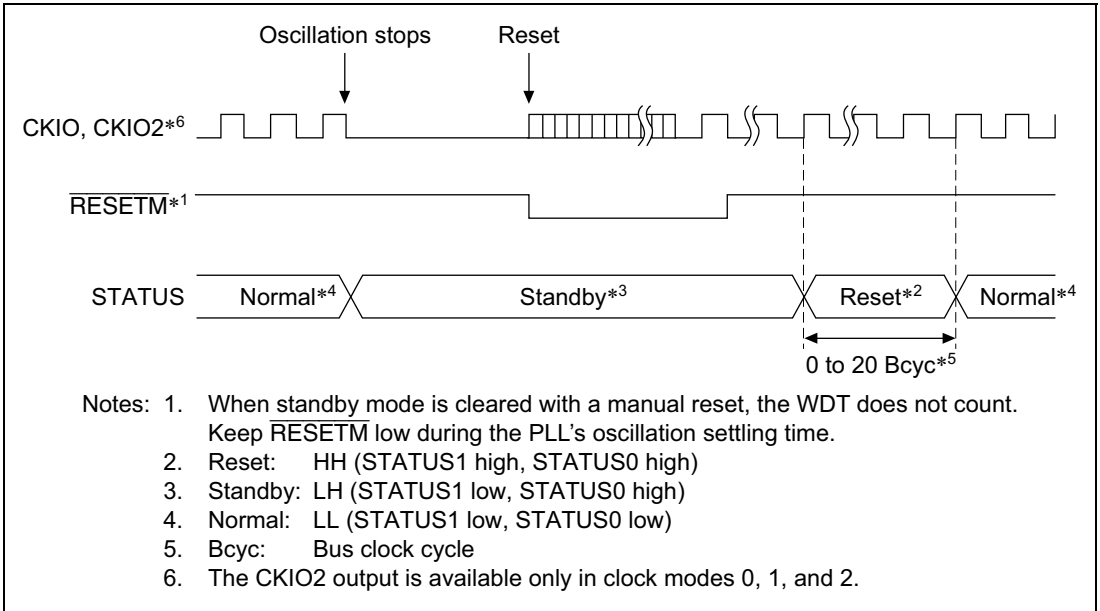

Figure 8.6 Standby to Manual Reset STATUS Output

8.6.3 Timing for Canceling Sleep Mode

Sleep to Interrupt

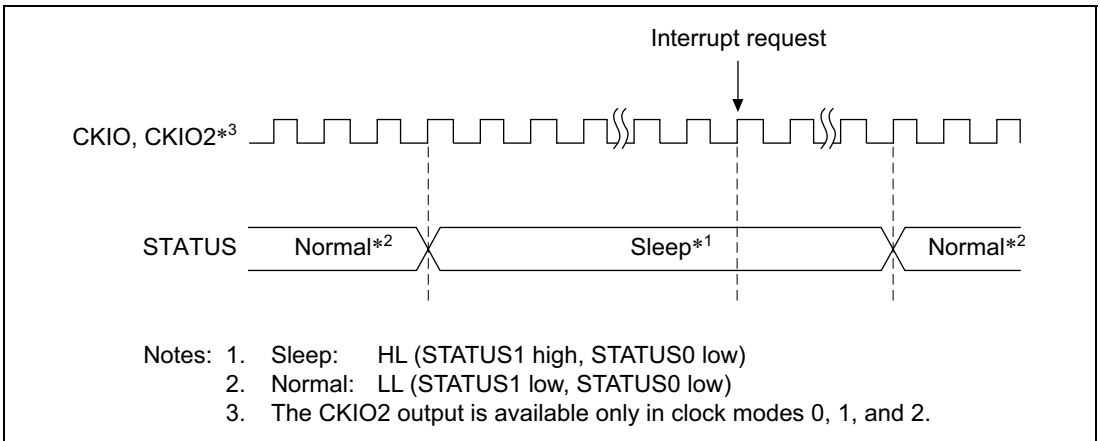

Figure 8.7 Sleep to Interrupt STATUS Output

Sleep to Power-On Reset

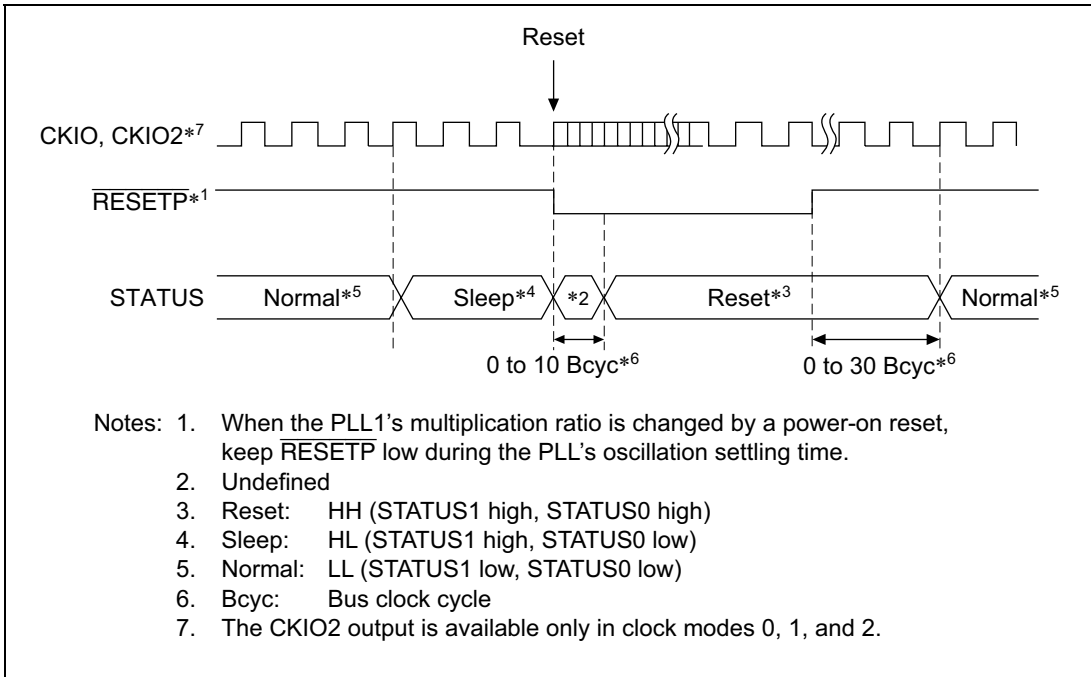

Figure 8.8 Sleep to Power-On Reset STATUS Output

Sleep to Manual Reset

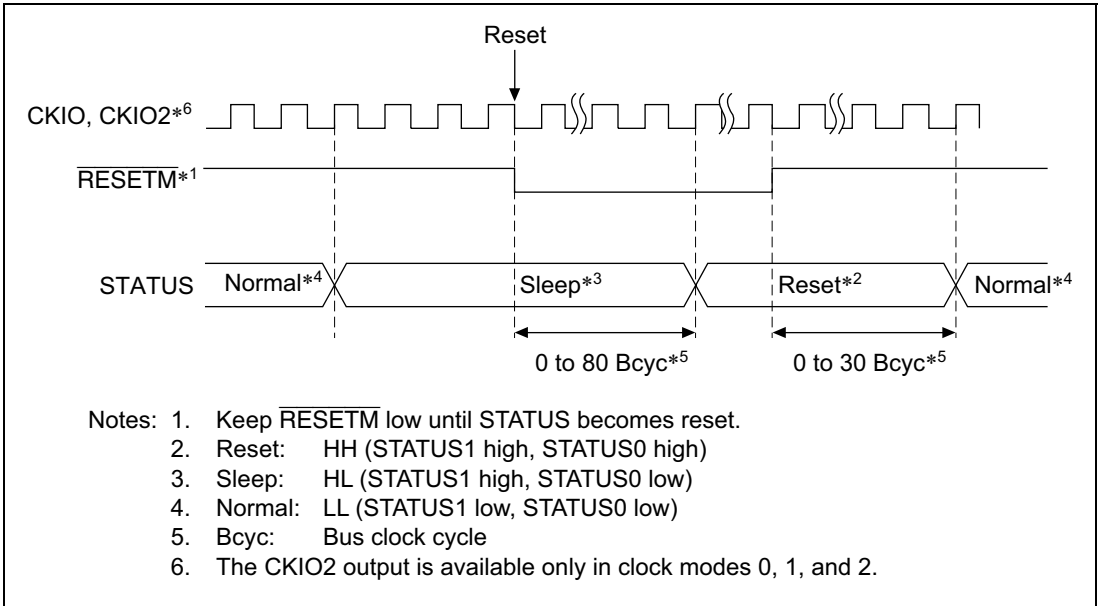

Figure 8.9 Sleep to Manual Reset STATUS Output

8.7 Hardware Standby Mode

8.7.1 Transition to Hardware Standby Mode

Driving the CA pin low causes a transition to hardware standby mode. In hardware standby mode, all modules except those operating on an RTC clock are halted, as in the standby mode entered on execution of a SLEEP instruction ((software) standby mode).

Hardware standby mode differs from (software) standby mode as follows.

1. Interrupts and manual resets are not accepted.
2. The TMU does not operate.

Operation when a low-level signal is input at the CA pin depends on the CPG state, as follows.

1. In standby mode
The clock remains stopped and the chip enters the hardware standby state. Acceptance of interrupts and manual resets is disabled, TCLK output is fixed low, and the TMU halts.
2. During WDT operation when standby mode is canceled by an interrupt
The chip enters hardware standby mode after standby mode is canceled and the CPU resumes operation.
3. In sleep mode
The chip enters hardware standby mode after sleep mode is canceled and the CPU resumes operation.

Hold the CA pin low in hardware standby mode.

8.7.2 Canceling Hardware Standby Mode

Hardware standby mode can only be canceled by a power-on reset.

When the CA pin is driven high while the $\overline{\text{RESETP}}$ pin is low, clock oscillation is started. Hold the $\overline{\text{RESETP}}$ pin low until clock oscillation stabilizes. When the $\overline{\text{RESETP}}$ pin is driven high, the CPU begins power-on reset processing.

Operation is not guaranteed in the event of an interrupt or manual reset.

8.7.3 Hardware Standby Mode Timing

Figures 8.10 and 8.11 show examples of pin timing in hardware standby mode.

The CA pin is sampled using EXTAL2 (32.768 kHz), and a hardware standby request is only recognized when the pin is low for two consecutive clock cycles.

The CA pin must be held low while the chip is in hardware standby mode.

Clock oscillation starts when the CA pin is driven high after the $\overline{\text{RESETP}}$ pin is driven low.

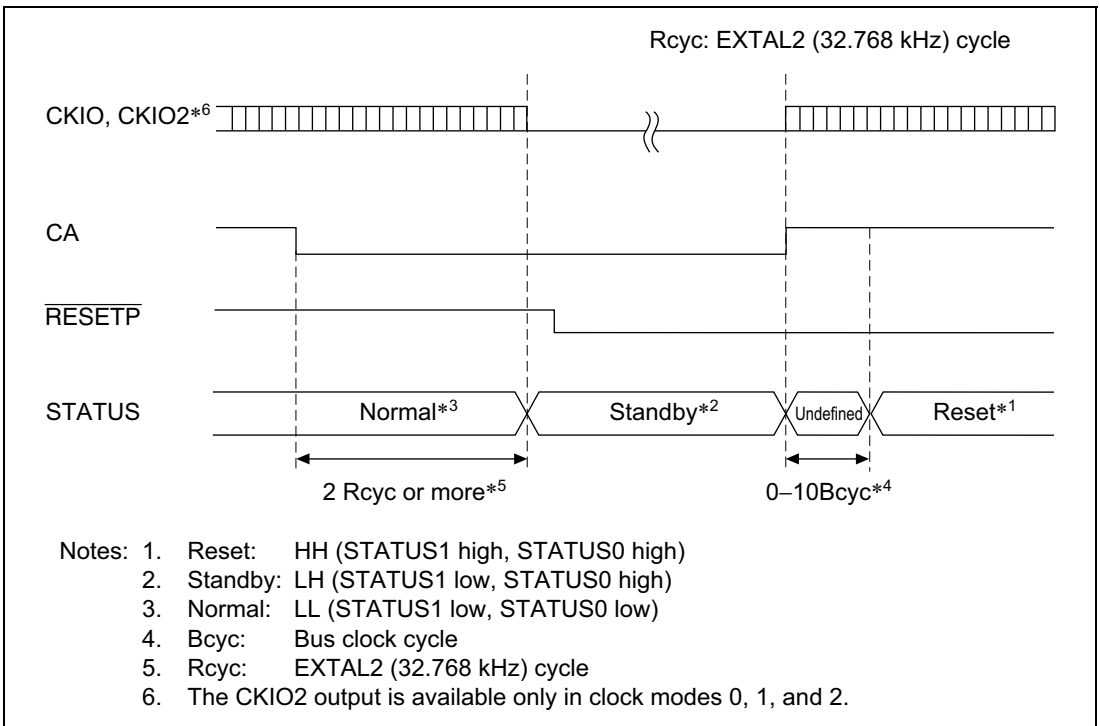

**Figure 8.10 Hardware Standby Mode
(When CA Goes Low in Normal Operation)**

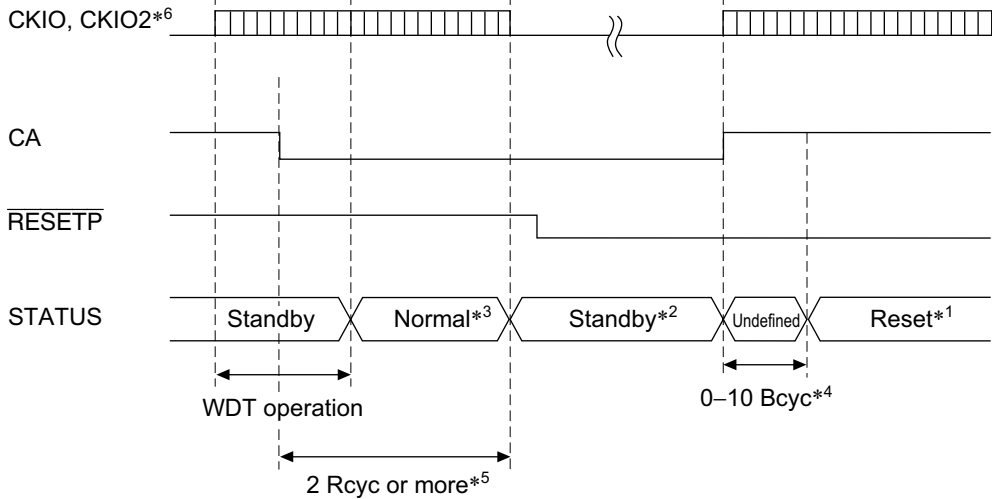

- Notes:
1. Reset: HH (STATUS1 high, STATUS0 high)
 2. Standby: LH (STATUS1 low, STATUS0 high)
 3. Normal: LL (STATUS1 low, STATUS0 low)
 4. Bcyc: Bus clock cycle
 5. Rcyc: EXTAL2 (32.768 kHz) cycle
 6. The CKIO2 output is available only in clock modes 0, 1, and 2.

Figure 8.11 Hardware Standby Mode Timing
(When CA Goes Low during WDT Operation on Standby Mode Cancellation)

Section 9 On-Chip Oscillation Circuits

9.1 Overview

The on-chip oscillation circuits consist of a clock pulse generator (CPG) block and a watchdog timer (WDT) block. The WDT is a single-channel timer that counts the clock settling time and is used when clearing standby mode and temporary standbys, such as frequency changes. It can also be used as an ordinary watchdog timer or interval timer.

9.1.1 Features

The CPG has the following features:

- Four clock modes: Selection of four clock modes for different frequency ranges, power consumption, direct crystal input, and external clock input.
- Three clocks generated independently: An internal clock for the CPU, cache, and TLB (I ϕ); a peripheral clock (P ϕ) for the on-chip peripheral modules; and a bus clock (CKIO) for the external bus interface.
- Frequency change function: Internal and peripheral clock frequencies can be changed independently using the PLL circuit and divider circuit within the CPG. Frequencies are changed by software using frequency control register (FRQCR) settings.
- Power-down mode control: The clock can be stopped for sleep mode and standby mode and specific modules can be stopped using the module standby function.

The WDT has the following features:

- Can be used to ensure the clock settling time: Use the WDT to cancel standby mode and the temporary standbys which occur when the clock frequency is changed.
- Can switch between watchdog timer mode and interval timer mode.
- Generates internal resets in watchdog timer mode: Internal resets occur after counter overflow. Selection of power-on reset or manual reset.
- Generates interrupts in interval timer mode: Internal timer interrupts occur after counter overflow.
- Selection of eight counter input clocks. Eight clocks ($\times 1$ to $\times 1/4096$) can be obtained by dividing the peripheral clock.

9.2 Overview of CPG

9.2.1 CPG Block Diagram

A block diagram of the on-chip clock pulse generator is shown in figure 9.1.

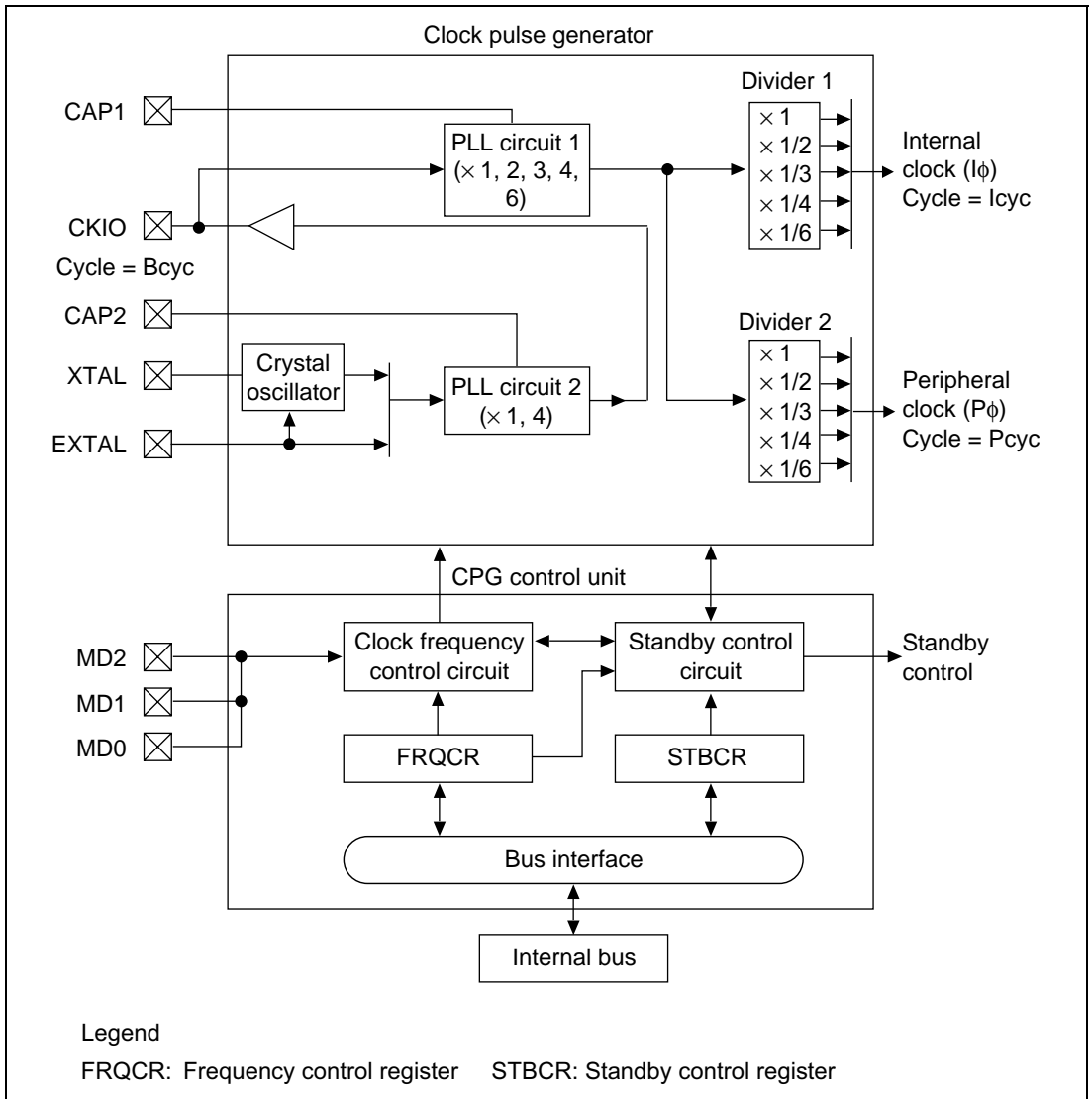

Figure 9.1 Block Diagram of Clock Pulse Generator

The clock pulse generator blocks function as follows:

1. PLL Circuit 1: PLL circuit 1 doubles, triples, quadruples, sextuples, or leaves unchanged the input clock frequency from the CKIO pin. The multiplication rate is set by the frequency control register. When this is done, the phase of the leading edge of the internal clock is controlled so that it will agree with the phase of the leading edge of the CKIO pin.
2. PLL Circuit 2: PLL circuit 2 leaves unchanged or quadruples the frequency of the crystal oscillator or the input clock frequency from the EXTAL pin. The multiplication ratio is fixed by the clock operation mode. The clock operation mode is set by pins MD0, MD1, and MD2. See table 9.3 for more information on clock operation modes.
3. Crystal Oscillator: This oscillator is used when a crystal oscillator element is connected to the XTAL and EXTAL pins. It operates according to the clock operating mode setting.
4. Divider 1: Divider 1 generates a clock at the operating frequency used by the internal clock. The operating frequency can be 1, 1/2, 1/3, 1/4 or 1/6 times the output frequency of PLL circuit 1, as long as it is not lower than the CKIO pin clock frequency. The division ratio is set in the frequency control register.
5. Divider 2: Divider 2 generates a clock at the operating frequency used by the peripheral clock. The operating frequency can be 1, 1/2, 1/3, 1/4 or 1/6 times the output frequency of PLL circuit 1 or the CKIO pin clock frequency, as long as it is not higher than the CKIO pin clock frequency. The division ratio is set in the frequency control register.
6. Clock Frequency Control Circuit: The clock frequency control circuit controls the clock frequency using the MD pins and the frequency control register.
7. Standby Control Circuit: The standby control circuit controls the state of the clock pulse generator and other modules during clock switching and sleep/standby modes.
8. Frequency Control Register: The frequency control register has control bits assigned for the following functions: the frequency multiplication ratio of PLL 1, and the frequency division ratio of the internal clock and the peripheral clock.
9. Standby Control Register: The standby control register has bits for controlling the power-down modes. See section 8, Power-Down Modes, for more information.

9.2.2 CPG Pin Configuration

Table 9.1 lists the CPG pins and their functions.

Table 9.1 CPG Pins and Functions

Pin Name	Symbol	I/O	Description
Mode control pins	MD0	I	Set the clock operating mode
	MD1	I	
	MD2	I	
Crystal I/O pins (clock input pins)	XTAL	O	Connects a crystal oscillator
	EXTAL	I	Connects a crystal oscillator. Also used to input an external clock
Clock I/O pin	CKIO	I/O	Inputs or outputs an external clock
Capacitor connection pins for PLL	CAP1	I	Connects capacitor for PLL circuit 1 operation (recommended value 470 pF)
	CAP2	I	Connects capacitor for PLL circuit 2 operation (recommended value 470 pF)

9.2.3 CPG Register Configuration

Table 9.2 shows the CPG register configuration.

Table 9.2 CPG Register

Register Name	Abbreviation	R/W	Initial Value	Address	Access Size
Frequency control register	FRQCR	R/W	H'0102	H'FFFFFF80	16

9.3 Clock Operating Modes

Table 9.3 shows the relationship between the mode control pin (MD2–MD0) combinations and the clock operating modes. Table 9.4 shows the usable frequency ranges in the clock operating modes.

Table 9.3 Clock Operating Modes

Mode	Pin Values			Clock I/O		PLL2 On/Off	PLL1 On/Off	Divider 1 Input	Divider 2 Input	CKIO Frequency
	MD2	MD1	MD0	Source	Output					
0	0	0	0	EXTAL	CKIO	On, multi- plication ratio: 1	On	PLL1 output	PLL1	(EXTAL)
1	0	0	1	EXTAL	CKIO	On, multi- plication ratio: 4	On	PLL1 output	PLL1	(EXTAL) × 4
2	0	1	0	Crystal oscillator	CKIO	On, multi- plication ratio: 4	On	PLL1 output	PLL1	(Crystal) × 4
7	1	1	1	CKIO	—	Off	On	PLL1 output	PLL1	(CKIO)
—	Except above value			Reserved						

Mode 0: An external clock is input from the EXTAL pin and undergoes waveform shaping by PLL circuit 2 before being supplied inside the chip. PLL circuit 1 is constantly on. An input clock frequency of 25 MHz to 66.67 MHz can be used, and the CKIO frequency range is 25 MHz to 66.67 MHz.

Mode 1: An external clock is input from the EXTAL pin and its frequency is multiplied by 4 by PLL circuit 2 before being supplied inside the chip, allowing a low-frequency external clock to be used. An input clock frequency of 6.25 MHz to 16.67 MHz can be used, and the CKIO frequency range is 25 MHz to 66.67 MHz.

Mode 2: The on-chip crystal oscillator operates, with the oscillation frequency being multiplied by 4 by PLL circuit 2 before being supplied inside the chip, allowing a low crystal frequency to be used. A crystal oscillation frequency of 6.25 MHz to 16.67 MHz can be used, and the CKIO frequency range is 25 MHz to 66.67 MHz.

Mode 7: In this mode, the CKIO pin is an input, an external clock is input to this pin, and undergoes waveform shaping, and also frequency multiplication according to the setting, by PLL circuit 1 before being supplied to the chip. In modes 0 to 2, the system clock is generated from the output of the chip's CKIO pin. Consequently, if a large number of ICs are operating on the clock cycle, the CKIO pin load will be large. This mode, however, assumes a comparatively large-scale system. If a large number of ICs are operating on the clock cycle, a clock generator with a number of low-skew clock outputs can be provided, so that the ICs can operate synchronously by distributing the clocks to each one.

As PLL circuit 1 compensates for fluctuations in the CKIO pin load, this mode is suitable for connection of synchronous DRAM.

Table 9.4 Available Combinations of Clock Mode and FRQCR Values

Clock Mode	FRQCR	PLL1	PLL2	Clock Rate* (I:B:P)	Input Frequency Range	CKIO Frequency Range
0	H'0100	ON (× 1)	ON (× 1)	1:1:1	25 MHz to 33.34 MHz	25 MHz to 33.34 MHz
	H'0101	ON (× 1)	ON (× 1)	1:1:1/2	25 MHz to 66.67 MHz	25 MHz to 66.67 MHz
	H'0102	ON (× 1)	ON (× 1)	1:1:1/4	25 MHz to 66.67 MHz	25 MHz to 66.67 MHz
	H'0111	ON (× 2)	ON (× 1)	2:1:1	25 MHz to 33.34 MHz	25 MHz to 33.34 MHz
	H'0112	ON (× 2)	ON (× 1)	2:1:1/2	25 MHz to 66.67 MHz	25 MHz to 66.67 MHz
	H'0115	ON (× 2)	ON (× 1)	1:1:1	25 MHz to 33.34 MHz	25 MHz to 33.34 MHz
	H'0116	ON (× 2)	ON (× 1)	1:1:1/2	25 MHz to 66.67 MHz	25 MHz to 66.67 MHz
	H'0122	ON (× 4)	ON (× 1)	4:1:1	25 MHz to 33.34 MHz	25 MHz to 33.34 MHz
	H'0126	ON (× 4)	ON (× 1)	2:1:1	25 MHz to 33.34 MHz	25 MHz to 33.34 MHz
	H'012A	ON (× 4)	ON (× 1)	1:1:1	25 MHz to 33.34 MHz	25 MHz to 33.34 MHz
	H'A100	ON (× 3)	ON (× 1)	3:1:1	25 MHz to 33.34 MHz	25 MHz to 33.34 MHz
	H'A101	ON (× 3)	ON (× 1)	3:1:1/2	25 MHz to 66.67 MHz	25 MHz to 66.67 MHz
	H'E100	ON (× 3)	ON (× 1)	1:1:1	25 MHz to 33.34 MHz	25 MHz to 33.34 MHz
	H'E101	ON (× 3)	ON (× 1)	1:1:1/2	25 MHz to 66.67 MHz	25 MHz to 66.67 MHz
	H'A111	ON (× 6)	ON (× 1)	6:1:1	25 MHz to 33.34 MHz	25 MHz to 33.34 MHz

Clock Mode	FRQCR	PLL1	PLL2	Clock Rate* (I:B:P)	Input Frequency Range	CKIO Frequency Range
1, 2	H'0100	ON (× 1)	ON (× 4)	4:4:4	6.25 MHz to 8.34 MHz	25 MHz to 33.34 MHz
	H'0101	ON (× 1)	ON (× 4)	4:4:2	6.25 MHz to 16.67 MHz	25 MHz to 66.67 MHz
	H'0102	ON (× 1)	ON (× 4)	4:4:1	6.25 MHz to 16.67 MHz	25 MHz to 66.67 MHz
	H'0111	ON (× 2)	ON (× 4)	8:4:4	6.25 MHz to 8.34 MHz	25 MHz to 33.34 MHz
	H'0112	ON (× 2)	ON (× 4)	8:4:2	6.25 MHz to 16.67 MHz	25 MHz to 66.67 MHz
	H'0115	ON (× 2)	ON (× 4)	4:4:4	6.25 MHz to 8.34 MHz	25 MHz to 33.34 MHz
	H'0116	ON (× 2)	ON (× 4)	4:4:2	6.25 MHz to 16.67 MHz	25 MHz to 66.67 MHz
	H'0122	ON (× 4)	ON (× 4)	16:4:4	6.25 MHz to 8.34 MHz	25 MHz to 33.34 MHz
	H'0126	ON (× 4)	ON (× 4)	8:4:4	6.25 MHz to 8.34 MHz	25 MHz to 33.34 MHz
	H'012A	ON (× 4)	ON (× 4)	4:4:4	6.25 MHz to 8.34 MHz	25 MHz to 33.34 MHz
	H'A100	ON (× 3)	ON (× 4)	12:4:4	6.25 MHz to 8.34 MHz	25 MHz to 33.34 MHz
	H'A101	ON (× 3)	ON (× 4)	12:4:2	6.25 MHz to 16.67 MHz	25 MHz to 66.67 MHz
	H'E100	ON (× 3)	ON (× 4)	4:4:4	6.25 MHz to 8.34 MHz	25 MHz to 33.34 MHz
	H'E101	ON (× 3)	ON (× 4)	4:4:2	6.25 MHz to 16.67 MHz	25 MHz to 66.67 MHz
	H'A111	ON (× 6)	ON (× 4)	24:4:4	6.25 MHz to 8.34 MHz	25 MHz to 33.34 MHz
7	H'0100	ON (× 1)	OFF	1:1:1	25 MHz to 33.34 MHz	25 MHz to 33.34 MHz
	H'0101	ON (× 1)	OFF	1:1:1/2	25 MHz to 66.67 MHz	25 MHz to 66.67 MHz
	H'0102	ON (× 1)	OFF	1:1:1/4	25 MHz to 66.67 MHz	25 MHz to 66.67 MHz
	H'0111	ON (× 2)	OFF	2:1:1	25 MHz to 33.34 MHz	25 MHz to 33.34 MHz
	H'0112	ON (× 2)	OFF	2:1:1/2	25 MHz to 66.67 MHz	25 MHz to 66.67 MHz
	H'0115	ON (× 2)	OFF	1:1:1	25 MHz to 33.34 MHz	25 MHz to 33.34 MHz
	H'0116	ON (× 2)	OFF	1:1:1/2	25 MHz to 66.67 MHz	25 MHz to 66.67 MHz
	H'0122	ON (× 4)	OFF	4:1:1	25 MHz to 33.34 MHz	25 MHz to 33.34 MHz
	H'0126	ON (× 4)	OFF	2:1:1	25 MHz to 33.34 MHz	25 MHz to 33.34 MHz
	H'012A	ON (× 4)	OFF	1:1:1	25 MHz to 33.34 MHz	25 MHz to 33.34 MHz
	H'A100	ON (× 3)	OFF	3:1:1	25 MHz to 33.34 MHz	25 MHz to 33.34 MHz
	H'A101	ON (× 3)	OFF	3:1:1/2	25 MHz to 66.67 MHz	25 MHz to 66.67 MHz
	H'E100	ON (× 3)	OFF	1:1:1	25 MHz to 33.34 MHz	25 MHz to 33.34 MHz
	H'E101	ON (× 3)	OFF	1:1:1/2	25 MHz to 66.67 MHz	25 MHz to 66.67 MHz
	H'A111	ON (× 6)	OFF	6:1:1	25 MHz to 33.34 MHz	25 MHz to 33.34 MHz

Do not set values other than those in the table above in the FRQCR register.

Note: * Taking input clock as 1.

Cautions:

1. The frequency of the internal clock ($I\phi$) becomes:
 - The product of the frequency of the CKIO pin, the frequency multiplication ratio of PLL circuit 1, and the division ratio of divider 1.
 - Do not set the internal clock frequency lower than the CKIO pin frequency.
2. The frequency of the peripheral clock ($P\phi$) becomes:
 - The product of the frequency of the CKIO pin, the frequency multiplication ratio of PLL circuit 1, and the division ratio of divider 2.
 - The peripheral clock frequency should not be set higher than the frequency of the CKIO pin, higher than 33.34 MHz.
3. The output frequency of PLL circuit 1 is the product of the CKIO frequency and the multiplication ratio of PLL circuit 1.
4. $\times 1$, $\times 2$, $\times 3$, $\times 4$, or $\times 6$ can be used as the multiplication ratio of PLL circuit 1. $\times 1$, $\times 1/2$, $\times 1/3$, $\times 1/4$, and $\times 1/6$ can be selected as the division ratios of dividers 1 and 2. Set the rate in the frequency control register. The on/off state of PLL circuit 2 is determined by the mode.

9.4 Register Descriptions

9.4.1 Frequency Control Register (FRQCR)

The frequency control register (FRQCR) is a 16-bit readable/writable register used to specify the frequency multiplication ratio of PLL circuit 1 and the frequency division ratio of the internal clock and the peripheral clock.

Only word access can be used on the FRQCR register.

FRQCR is initialized to H'0102 by a power-on reset, but retains its value in a manual reset and in standby mode.

FRQCR:

Bit:	15	14	13	12	11	10	9	8
	STC2	IFC2	PFC2	—	—	—	—	—
Initial value:	0	0	0	0	0	0	0	1
R/W:	R/W	R/W	R/W	R	R	R	R	R
Bit:	7	6	5	4	3	2	1	0
	—	—	STC1	STC0	IFC1	IFC0	PFC1	PFC0
Initial value:	0	0	0	0	0	0	1	0
R/W:	R	R	R/W	R/W	R/W	R/W	R/W	R/W

Bits 15, 5, and 4—Frequency Multiplication Ratio (STC): These bits specify the frequency multiplication ratio of PLL circuit 1.

Bit 15: STC2	Bit 5: STC1	Bit 4: STC0	Description
0	0	0	× 1 (Initial value)
0	0	1	× 2
1	0	0	× 3
0	1	0	× 4
1	0	1	× 6
Except above value			Reserved

Bits 14, 3, and 2—Internal Clock Frequency Division Ratio (IFC): These bits specify the frequency division ratio of the internal clock with respect to the output frequency of PLL circuit 1.

Bit 14: IFC2	Bit 3: IFC1	Bit 2: IFC0	Description
0	0	0	× 1 (Initial value)
0	0	1	× 1/2
1	0	0	× 1/3
0	1	0	× 1/4
Except above value			Reserved (Setting prohibited)

Note: Do not set the internal clock frequency lower than the CKIO pin frequency.

Bits 13, 1, and 0—Peripheral Clock Frequency Division Ratio (PFC): These bits specify the division ratio of the peripheral clock frequency with respect to the frequency of the output frequency of PLL circuit 1 or the frequency of the CKIO pin.

Bit 13: PFC2	Bit 1: PFC1	Bit 0: PFC0	Description
0	0	0	× 1
0	0	1	× 1/2
1	0	0	× 1/3
0	1	0	× 1/4 (Initial value)
1	0	1	× 1/6
Except above value			Reserved (Setting prohibited)

Note: Do not set the peripheral clock frequency higher than the CKIO pin frequency.

Bits 12 to 9, 7, and 6—Reserved: These bits are always read as 0. The write value should always be 0.

Bit 8—Reserved: This bit is always read as 1. The write value should always be 1.

9.5 Changing the Frequency

The frequency of the internal clock and peripheral clock can be changed either by changing the multiplication ratio of PLL circuit 1 or by changing the division ratios of dividers 1 and 2. All of these are controlled by software through the frequency control register. The methods are described below. To the FRQCR register, do not set values other than those given in table 9.4.

9.5.1 Changing the Multiplication Rate

A PLL settling time is required when the multiplication rate of PLL circuit 1 is changed. The on-chip WDT counts the settling time.

1. In the initial state, the multiplication rate of PLL circuit 1 is 1.
2. Set a value that will become the specified oscillation settling time in the WDT and stop the WDT. The following must be set:
WTCSR register TME bit = 0: WDT stops
WTCSR register CKS2–CKS0 bits: Division ratio of WDT count clock
WTCNT counter: Initial counter value
3. Set the desired value in the STC2 to STC0 bits. The division ratio can also be set in the IFC2–IFC0 bits and PFC2–PFC0 bits.
4. The processor pauses internally and the WDT starts incrementing. In clock modes 0–2 and 7, the internal and peripheral clocks both stop. (except for the peripheral clock supplied to the WDT)
5. Supply of the clock that has been set begins at WDT count overflow, and the processor begins operating again. The WDT stops after it overflows.

When the following three conditions are all met, FRQCR should not be changed while a DMAC transfer is in progress.

- Bits IFC2 to IFC0 are changed.
- STC2 to STC0 are not changed.
- The clock ratio of $I\phi$ (on-chip clock) to $B\phi$ (bus clock) after the change is other than 1:1.

9.5.2 Changing the Division Ratio

The WDT will not count unless the multiplication ratio is changed simultaneously.

1. In the initial state, IFC2–IFC0 = 000 and PFC2–PFC0 = 010.
2. Set the IFC2, IFC1, IFC0, PFC2, PFC1, and PFC0 bits to the new division ratio. The values that can be set are limited by the clock mode and the multiplication ratio of PLL circuit 1. Note that if the wrong value is set, the processor will malfunction.
3. The clock is immediately supplied at the new division ratio.

9.7 WDT Registers

9.7.1 Watchdog Timer Counter (WTCNT)

The watchdog timer counter (WTCNT) is an 8-bit readable/writable counter that increments on the selected clock. WTCNT differs from other registers in that it is more difficult to write to. See section 9.7.3, Notes on Register Access, for details. When an overflow occurs, it generates a reset in watchdog timer mode and an interrupt in interval time mode. Its address is H'FFFFFF84. The WTCNT counter is initialized to H'00 only by a power-on reset through the $\overline{\text{RESETP}}$ pin. Use word access to write to the WTCNT counter, with H'5A in the upper byte. Use byte access to read WTCNT.

Bit:	7	6	5	4	3	2	1	0
Initial value:	0	0	0	0	0	0	0	0
R/W:	R/W	R/W	R/W	R/W	R/W	R/W	R/W	R/W

9.7.2 Watchdog Timer Control/Status Register (WTCSR)

The watchdog timer control/status register (WTCSR) is an 8-bit readable/writable register composed of bits to select the clock used for the count, bits to select the timer mode, and overflow flags. WTCSR differs from other registers in that it is more difficult to write to. See section 9.7.3, Notes on Register Access, for details. Its address is H'FFFFFF86. The WTCSR register is initialized to H'00 only by a power-on reset through the $\overline{\text{RESETP}}$ pin. When a WDT overflow causes an internal reset, WTCSR retains its value. When used to count the clock settling time for canceling a standby, it retains its value after counter overflow. Use word access to write to the WTCSR counter, with H'A5 in the upper byte. Use byte access to read WTCSR.

Bit:	7	6	5	4	3	2	1	0
	TME	WT/ $\overline{\text{IT}}$	RSTS	WOVF	IOVF	CKS2	CKS1	CKS0
Initial value:	0	0	0	0	0	0	0	0
R/W:	R/W	R/W	R/W	R/W	R/W	R/W	R/W	R/W

Bit 7—Timer Enable (TME): Starts and stops timer operation. Clear this bit to 0 when using the WDT in standby mode or when changing the clock frequency.

Bit 7: TME	Description
0	Timer disabled: Count-up stops and WTCNT value is retained (Initial value)
1	Timer enabled

Bit 6—Timer Mode Select (WT/IT̄): Selects whether to use the WDT as a watchdog timer or an interval timer.

Bit 6: WT/IT̄	Description
0	Used as interval timer (Initial value)
1	Used as watchdog timer

Note: If WT/IT̄ is modified when the WDT is running, the up-count may not be performed correctly.

Bit 5—Reset Select (RSTS): Selects the type of reset when WTCNT overflows in watchdog timer mode. In interval timer mode, this setting is ignored.

Bit 5: RSTS	Description
0	Power-on reset (Initial value)
1	Manual reset

Note: RESETOUT is output.

Bit 4—Watchdog Timer Overflow (WOVF): Indicates that the WTCNT has overflowed in watchdog timer mode. This bit is not set in interval timer mode.

Bit 4: WOVF	Description
0	No overflow (Initial value)
1	WTCNT has overflowed in watchdog timer mode

Bit 3—Interval Timer Overflow (IOVF): Indicates that WTCNT has overflowed in interval timer mode. This bit is not set in watchdog timer mode.

Bit 3: IOVF	Description
0	No overflow (Initial value)
1	WTCNT has overflowed in interval timer mode

Bits 2 to 0—Clock Select 2 to 0 (CKS2 to CKS0): These bits select the clock to be used for the WTCNT count from the eight types obtainable by dividing the peripheral clock. The overflow period in the table is the value when the peripheral clock (Pφ) is 15 MHz.

Bit 2: CKS2	Bit 1: CKS1	Bit 0: CKS0	Clock Division Ratio	Overflow Period (when P ϕ = 15 MHz)
0	0	0	1 (Initial value)	17 μ s
		1	1/4	68 μ s
	1	0	1/16	273 μ s
		1	1/32	546 μ s
1	0	0	1/64	1.09 ms
		1	1/256	4.36 ms
	1	0	1/1024	17.48 ms
		1	1/4096	69.91 ms

Note: If bits CKS2–CKS0 are modified when the WDT is running, the up-count may not be performed correctly. Ensure that these bits are modified only when the WDT is not running.

9.7.3 Notes on Register Access

The watchdog timer counter (WTCNT) and watchdog timer control/status register (WTCSR) are more difficult to write to than other registers. The procedure for writing to these registers is given below.

Writing to WTCNT and WTCSR: These registers must be written to using a word transfer instruction. They cannot be written to with a byte or longword transfer instruction. When writing to WTCNT, set the upper byte to H'5A and transfer the lower byte as the write data, as shown in figure 9.3. When writing to WTCSR, set the upper byte to H'A5 and transfer the lower byte as the write data. This transfer procedure writes the lower byte data to WTCNT or WTCSR.

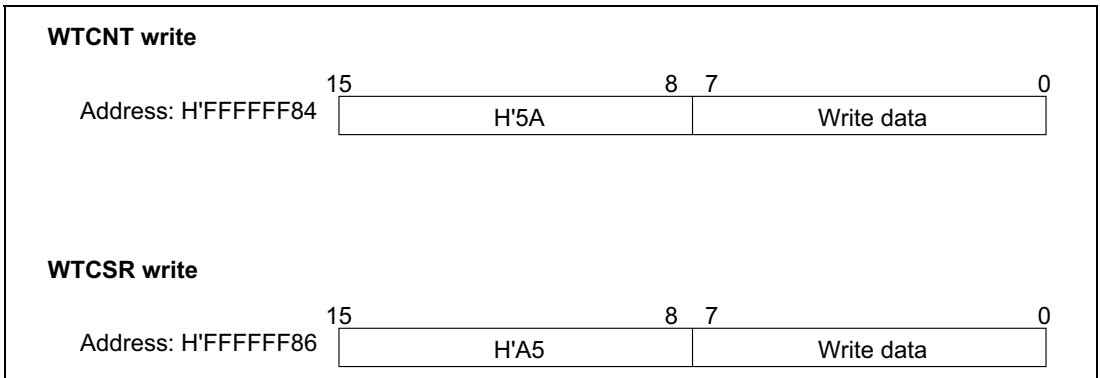

Figure 9.3 Writing to WTCNT and WTCSR

9.8 Using the WDT

9.8.1 Canceling Standby

The WDT can be used to cancel standby mode with an NMI or other interrupt. The procedure is described below. (The WDT does not run when a reset is used for canceling, so keep the RESET pin low until the clock stabilizes.)

1. Before transitioning to standby mode, always clear the TME bit in WTCSR to 0. When the TME bit is 1, an erroneous reset or interval timer interrupt may be generated when the count overflows.
2. Set the type of count clock used in the CKS2–CKS0 bits in WTCSR and the initial values for the counter in the WTCNT counter. These values should ensure that the time till count overflow is longer than the clock oscillation settling time.
3. Switch to standby mode by executing a SLEEP instruction to stop the clock.
4. The WDT starts counting by detecting the edge change of the NMI signal or detecting interrupts.
5. When the WDT count overflows, the CPG starts supplying the clock and the processor resumes operation. The WOVS flag in WTCSR is not set when this happens.
6. Since the WDT continues counting from H'00, set the STBY bit in the STBCR register to 0 in the interrupt handling routine and this will stop the WDT. When the STBY bit remains at 1, the SH7709S again enters standby mode when the WDT has counted up to H'80. This standby mode can be canceled by a power-on reset.

9.8.2 Changing the Frequency

To change the frequency used by the PLL, use the WDT. When changing the frequency only by switching the divider, do not use the WDT.

1. Before changing the frequency, always clear the TME bit in WTCSR to 0. When the TME bit is 1, an erroneous reset or interval timer interrupt may be generated when the count overflows.
2. Set the type of count clock used in the CKS2–CKS0 bits of WTCSR and the initial values for the counter in the WTCNT counter. These values should ensure that the time till count overflow is longer than the clock oscillation settling time.
3. When the frequency control register (FRQCR) is written to, the clock stops and the processor enters standby mode temporarily. The WDT starts counting.
4. When the WDT count overflows, the CPG resumes supplying the clock and the processor resumes operation. The WOVS flag in WTCSR is not set when this happens.
5. The counter stops at a value of H'00 or H'01. The stop value depends on the clock ratio.

When the following three conditions are all met, FRQCR should not be changed while a DMAC transfer is in progress.

- Bits IFC2 to IFC0 are changed.
- STC2 to STC0 are not changed.
- The clock ratio of I ϕ (on-chip clock) to B ϕ (bus clock) after the change is other than 1:1.

9.8.3 Using Watchdog Timer Mode

1. Set the $\overline{WT/IT}$ bit in the WTCSR register to 1, set the reset type in the RSTS bit, set the type of count clock in the CKS2–CKS0 bits, and set the initial value of the counter in the WTCNT counter.
2. Set the TME bit in WTCSR to 1 to start the count in watchdog timer mode.
3. While operating in watchdog timer mode, rewrite the counter periodically to H'00 to prevent the counter from overflowing.
4. When the counter overflows, the WDT sets the WOVF flag in WTCSR to 1 and generates the type of reset specified by the RSTS bit. The counter then resumes counting. When a reset is generated, a low level is output at the $\overline{RESETOUT}$ pin, and a high level at the STATUS0 and STATUS1 pins. The output period is approximately 1 count clock cycle in the case of a power-on reset, and approximately 5 peripheral clock cycles in the case of a manual reset.

9.8.4 Using Interval Timer Mode

When operating in interval timer mode, interval timer interrupts are generated at every overflow of the counter. This enables interrupts to be generated at set periods.

1. Clear the $\overline{WT/IT}$ bit in the WTCSR register to 0, set the type of count clock in the CKS2–CKS0 bits, and set the initial value of the counter in the WTCNT counter.
2. Set the TME bit in WTCSR to 1 to start the count in interval timer mode.
3. When the counter overflows, the WDT sets the IOVF flag in WTCSR to 1 and an interval timer interrupt request is sent to the INTC. The counter then resumes counting.

9.9 Notes on Board Design

When Using an External Crystal Resonator: Place the crystal resonator, capacitors CL1 and CL2 close to the EXTAL and XTAL pins. To prevent induction from interfering with correct oscillation, use a common grounding point for the capacitors connected to the resonator, and do not locate a wiring pattern near these components.

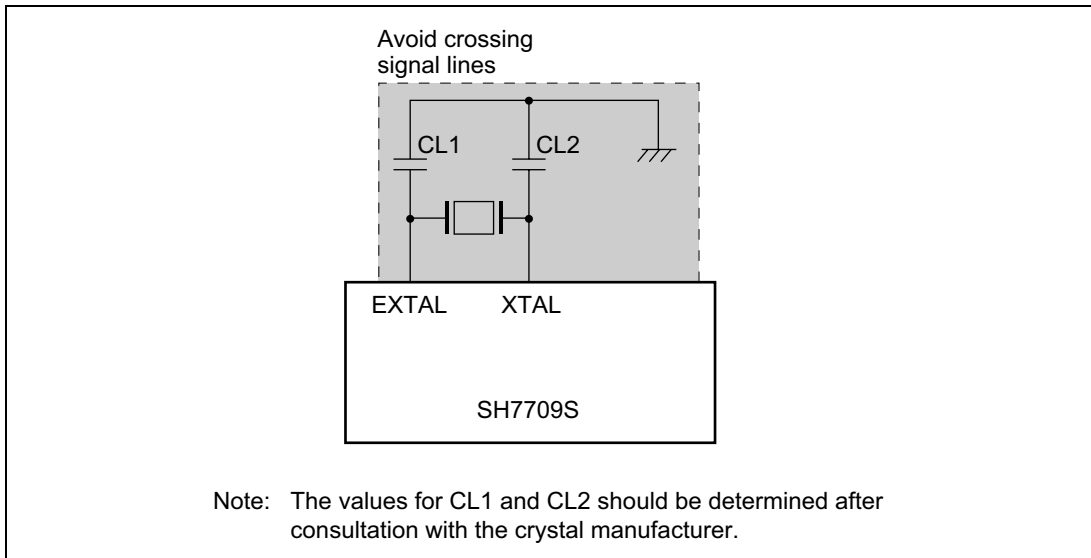

Figure 9.4 Points for Attention when Using Crystal Resonator

Decoupling Capacitors: Insert a laminated ceramic capacitor of 0.1 to 1 μF as a passive capacitor for each $V_{\text{SS}}/V_{\text{CC}}$ pair. Mount the passive capacitors close to the SH7709S power supply pins, and use components with a frequency characteristic suitable for the chip's operating frequency, as well as a suitable capacitance value.

Digital system $V_{\text{SS}}/V_{\text{CC}}$ pairs: 19-21, 27-29, 33-35, 45-47, 57-59, 69-71, 79-81, 83-85, 95-97, 109-111, 132-134, 153-154, 161-163, 173-175, 181-183, 205-208

On-chip oscillator $V_{\text{SS}}/V_{\text{CC}}$ pairs: 3-6, 145-147, 148-150

Note: The pin numbers above apply to LQFP and HQFP packages.

When Using a PLL Oscillator Circuit: Keep the wiring from the PLL V_{CC} and V_{SS} connection pattern to the power supply pins short, and make the pattern width large, to minimize the inductance component. Ground the oscillation stabilization capacitors C1 and C2 to V_{SS} (PLL1) and V_{SS} (PLL2), respectively. Place C1 and C2 close to the CAP1 and CAP2 pins and do not locate a wiring pattern in the vicinity. In clock mode 7, connect the EXTAL pin to V_{CC} or V_{SS} and leave the XTAL pin open.

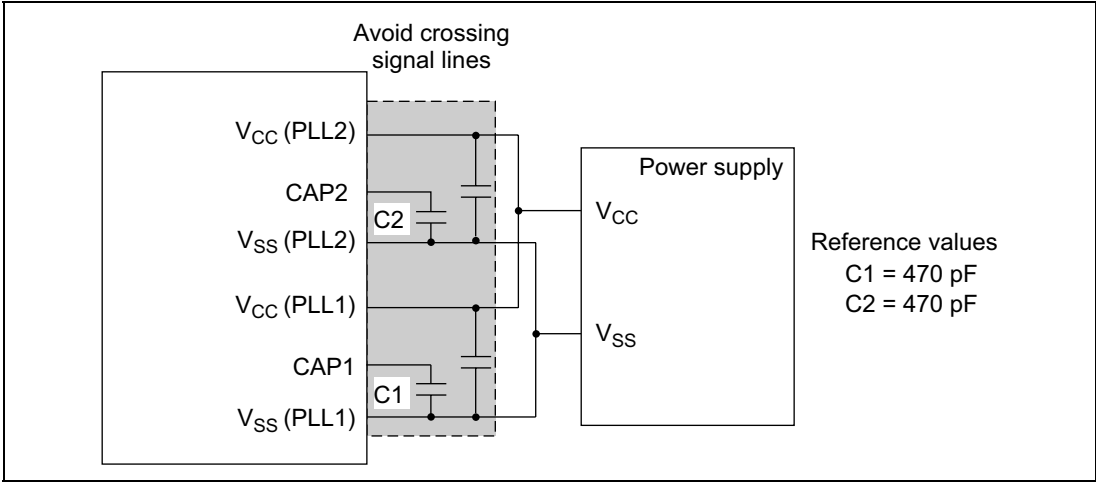

Figure 9.5 Points for Attention when Using PLL Oscillator Circuit

Section 10 Bus State Controller (BSC)

10.1 Overview

The bus state controller (BSC) divides physical address space and output control signals for various types of memory and bus interface specifications. BSC functions enable the chip to link directly with synchronous DRAM, SRAM, ROM, and other memory storage devices without an external circuit. The BSC also allows direct connection to PCMCIA interfaces, simplifying system design and allowing high-speed data transfers in a compact system.

10.1.1 Features

The BSC has the following features:

- Physical address space is divided into six areas
 - A maximum 64 Mbytes for each of the six areas, 0, 2–6
 - Area bus width can be selected by register (area 0 is set by external pin)
 - Wait states can be inserted using the $\overline{\text{WAIT}}$ pin
 - Wait state insertion can be controlled through software. Register settings can be used to specify the insertion of 1–10 cycles independently for each area (1–38 cycles for areas 5 and 6 and the PCMCIA interface only)
 - The type of memory connected can be specified for each area, and control signals are output for direct memory connection
 - Wait cycles are automatically inserted to avoid data bus conflict for continuous memory accesses to different areas or writes directly following reads in the same area
- Direct interface to synchronous DRAM
 - Multiplexes row/column addresses according to synchronous DRAM capacity
 - Supports burst operation
 - Supports bank active mode
 - Has both auto-refresh and self-refresh functions
 - Controls timing of synchronous DRAM direct-connection control signals according to register setting
- Burst ROM interface
 - Insertion of wait states controllable through software
 - Register setting control of burst transfers
- PCMCIA direct-connection interface
 - Insertion of wait states controllable through software
 - Bus sizing function for I/O bus width (only in little-endian mode)

- Short refresh cycle control
 - The overflow interrupt function of the refresh counter enables the refresh function immediately after a self-refresh operation using low power-consumption DRAM
- The refresh counter can be used as an interval timer
 - Outputs an interrupt request signal using the compare-match function
 - Outputs an interrupt request signal when the refresh counter overflows

10.1.2 Block Diagram

Figure 10.1 shows a block diagram of the bus state controller.

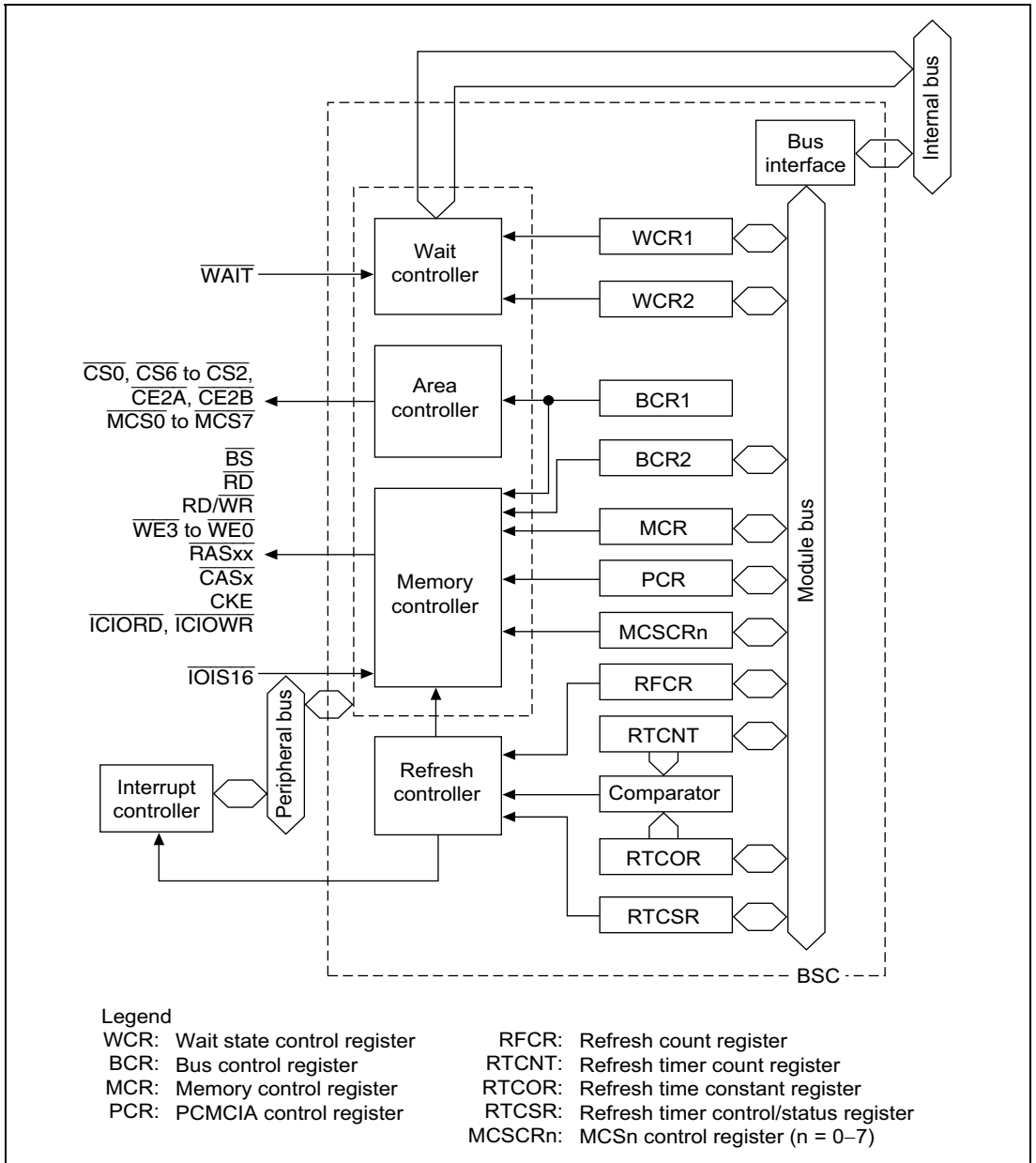

Figure 10.1 Block Diagram of Bus State Controller

10.1.3 Pin Configuration

Table 10.1 shows the BSC pin configuration.

Table 10.1 BSC Pins

Pin Name	Signal	I/O	Description
Address bus	A25–A0	O	Address output
Data bus	D15–D0	I/O	Data I/O
	D31–D16	I/O	Data I/O when using 32-bit bus width
Bus cycle start	\overline{BS}	O	Shows start of bus cycle. During burst transfers, asserted every data cycle.
Chip select 0, 2–4	$\overline{CS0}$, $\overline{CS2}$ – $\overline{CS4}$	O	Chip select signals to indicate area being accessed.
Chip select 5, 6	$\overline{CS5/CE1A}$, $\overline{CS6/CE1B}$	O	Chip select signals to indicate area being accessed. $\overline{CS5/CE1A}$ and $\overline{CS6/CE1B}$ can also be used as $\overline{CE1A}$ and $\overline{CE1B}$ of PCMCIA.
PCMCIA card select	$\overline{CE2A}$, $\overline{CE2B}$	O	$\overline{CE2A}$ and $\overline{CE2B}$ signals when PCMCIA is used
Read/write	$\overline{RD/WR}$	O	Data bus direction indication signal. PCMCIA write indication signal.
Row address strobe 3L	$\overline{RAS3L}$	O	When synchronous DRAM is used, $\overline{RAS3L}$ for lower 32-Mbyte address and 64-Mbyte address.
Row address strobe 3U	$\overline{RAS3U}$	O	When synchronous DRAM is used, $\overline{RAS3U}$ for upper 32-Mbyte address.
Column address strobe	\overline{CASL}	O	When synchronous DRAM is used, \overline{CASL} signal for lower 32-Mbyte address and 64-Mbyte address.
Column address strobe LH	\overline{CASU}	O	When synchronous DRAM is used, \overline{CASU} signal for upper 32-Mbyte address.
Data enable 0	$\overline{WE0/DQMLL}$	O	When memory other than synchronous DRAM is used, D7–D0 write strobe signal. When synchronous DRAM is used, selects D7–D0.
Data enable 1	$\overline{WE1/DQMLU/WE}$	O	When memory other than synchronous DRAM and PCMCIA is used, D15–D8 write strobe signal. When synchronous DRAM is used, selects D15–D8. When PCMCIA is used, strobe signal indicating write cycle.
Data enable 2	$\overline{WE2/DQMUL/ICIORD}$	O	When memory other than synchronous DRAM and PCMCIA is used, D23–D16 write strobe signal. When synchronous DRAM is used, selects D23–D16. When PCMCIA is used, strobe signal indicating I/O read.

Pin Name	Signal	I/O	Description
Data enable 3	$\overline{WE3/DQM0U}/\overline{ICIOWR}$	O	When memory other than synchronous DRAM and PCMCIA is used, D31–D24 write strobe signal. When synchronous DRAM is used, selects D31–D24. When PCMCIA is used, strobe signal indicating I/O write.
Read	\overline{RD}	O	Strobe signal indicating read cycle
Wait	\overline{WAIT}	I	Wait state request signal
Clock enable	CKE	O	Clock enable control signal for synchronous DRAM
IOIS16	$\overline{IOIS16}$	I	Signal indicating PCMCIA 16-bit I/O. Valid only in little-endian mode.
Bus release request	\overline{BREQ}	I	Bus release request signal
Bus release acknowledgment	\overline{BACK}	O	Bus release acknowledge signal
Mask ROM chip select	$\overline{MCS[0]}-\overline{MCS[7]}$	O	Chip select signal for mask ROM connected to area 0 or 2.

10.1.4 Register Configuration

The BSC has 21 registers (table 10.2). Synchronous DRAM also has a built-in synchronous DRAM mode register. These registers control direct connection interfaces to memory, wait states, and refreshes devices.

Table 10.2 BSC Registers

Name	Abbr.	R/W	Initial Value*	Address	Bus Width
Bus control register 1	BCR1	R/W	H'0000	H'FFFFFF60	16
Bus control register 2	BCR2	R/W	H'3FF0	H'FFFFFF62	16
Wait state control register 1	WCR1	R/W	H'3FF3	H'FFFFFF64	16
Wait state control register 2	WCR2	R/W	H'FFFF	H'FFFFFF66	16
Individual memory control register	MCR	R/W	H'0000	H'FFFFFF68	16
PCMCIA control register	PCR	R/W	H'0000	H'FFFFFF6C	16
Refresh timer control/status register	RTCSR	R/W	H'0000	H'FFFFFF6E	16
Refresh timer counter	RTCNT	R/W	H'0000	H'FFFFFF70	16
Refresh time constant register	RTCOR	R/W	H'0000	H'FFFFFF72	16
Refresh count register	RFCR	R/W	H'0000	H'FFFFFF74	16
Synchronous DRAM mode register, area 2	SDMR	W	—	H'FFFD000– H'FFFDFFF	8
Synchronous DRAM mode register, area 3				H'FFFE000– H'FFFEFFF	
MCS0 control register	MCSCR0	R/W	H'0000	H'FFFFFF50	16
MCS1 control register	MCSCR1	R/W	H'0000	H'FFFFFF52	16
MCS2 control register	MCSCR2	R/W	H'0000	H'FFFFFF54	16
MCS3 control register	MCSCR3	R/W	H'0000	H'FFFFFF56	16
MCS4 control register	MCSCR4	R/W	H'0000	H'FFFFFF58	16
MCS5 control register	MCSCR5	R/W	H'0000	H'FFFFFF5A	16
MCS6 control register	MCSCR6	R/W	H'0000	H'FFFFFF5C	16
MCS7 control register	MCSCR7	R/W	H'0000	H'FFFFFF5E	16

Notes: For details, see section 10.2.7, Synchronous DRAM Mode Register (SDMR).

* Initialized by a power-on reset.

10.1.5 Area Overview

Space Allocation: In the architecture of the SH7709S, both logical spaces and physical spaces have 32-bit address spaces. The logical space is divided into five areas by the value of the upper bits of the address. The physical space is divided into eight areas.

Logical space can be allocated to physical space using a memory management unit (MMU). For details, refer to section 3, Memory Management Unit (MMU), which describes area allocation for physical space.

As shown in table 10.3, the SH7709S can be connected directly to six memory/PCMCIA interface areas, and it outputs chip select signals ($\overline{CS0}$, $\overline{CS2}$ – $\overline{CS6}$, $\overline{CE2A}$, $\overline{CE2B}$) for each of them. $\overline{CS0}$ is asserted during area 0 access; $\overline{CS6}$ is asserted during area 6 access. When PCMCIA interface is selected in area 5 or 6, in addition to $\overline{CS5}/\overline{CS6}$, $\overline{CE2A}/\overline{CE2B}$ are asserted for the corresponding bytes accessed.

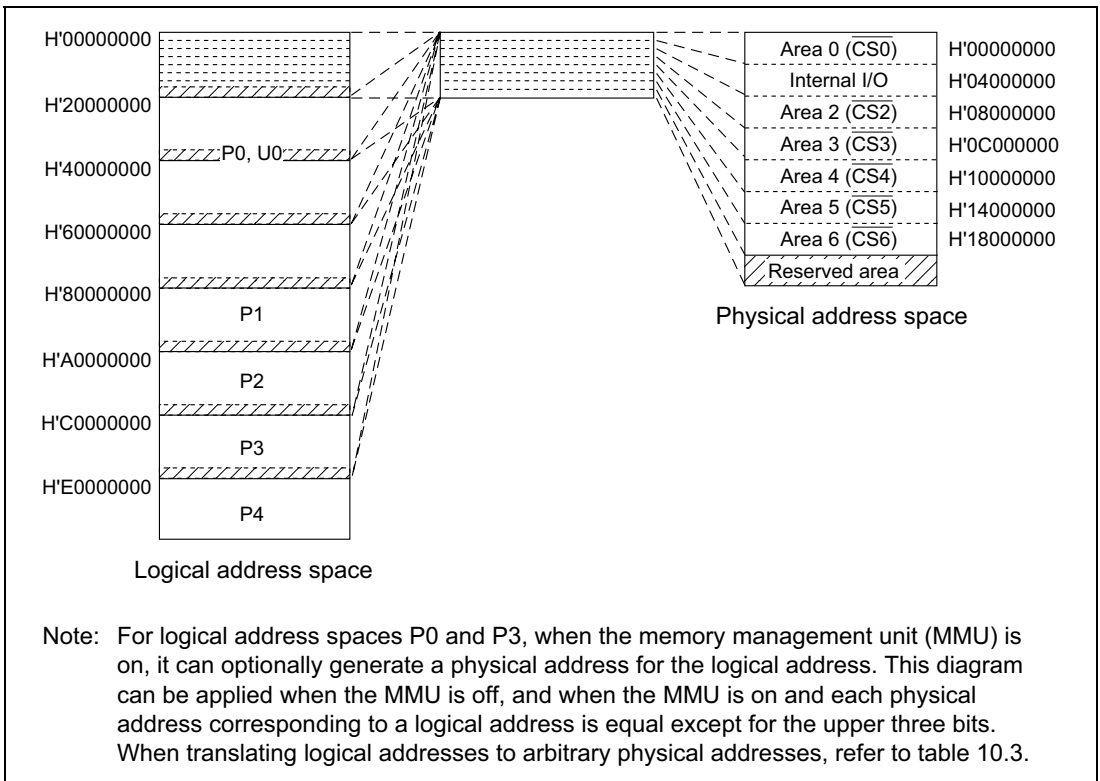

Figure 10.2 Correspondence between Logical Address Space and Physical Address Space

Table 10.3 Physical Address Space Map

Area	Connectable Memory	Physical Address	Capacity	Access Size
0	Ordinary memory ^{*1} , burst ROM	H'00000000 to H'03FFFFFF	64 Mbytes	8, 16, 32 ^{*2}
		H'00000000 + H'20000000 × n to H'03FFFFFF + H'20000000 × n	Shadow	n = 1–6
1	Internal I/O registers ^{*7}	H'04000000 to H'07FFFFFF	64 Mbytes	8, 16, 32 ^{*3}
		H'04000000 + H'20000000 × n to H'07FFFFFF + H'20000000 × n	Shadow	n = 1–6
2	Ordinary memory ^{*1} , synchronous DRAM	H'08000000 to H'0BFFFFFF	64 Mbytes	8, 16, 32 ^{*3 *4}
		H'08000000 + H'20000000 × n to H'0BFFFFFF + H'20000000 × n	Shadow	n = 1–6
3	Ordinary memory ^{*1} , synchronous DRAM	H'0C000000 to H'0FFFFFFF	64 Mbytes	8, 16, 32 ^{*3 *4}
		H'0C000000 + H'20000000 × n to H'0FFFFFFF + H'20000000 × n	Shadow	n = 1–6
4	Ordinary memory ^{*1}	H'10000000 to H'13FFFFFF	64 Mbytes	8, 16, 32 ^{*3}
		H'10000000 + H'20000000 × n to H'13FFFFFF + H'20000000 × n	Shadow	n = 1–6
5	Ordinary memory ^{*1} , PCMCIA, burst ROM Ordinary memory, burst ROM	H'14000000 to H'15FFFFFF	32 Mbytes	8, 16, 32 ^{*3 *5}
		H'16000000 to H'17FFFFFF	32 Mbytes	
6	Ordinary memory ^{*1} , PCMCIA, burst ROM	H'18000000 to H'19FFFFFF	32 Mbytes	8, 16, 32 ^{*3 *5}
		H'1A000000 to H'1BFFFFFF		
7 ^{*6}	Reserved area	H'18000000 + H'20000000 × n to H'1BFFFFFF + H'20000000 × n	Shadow	n = 1–6
		H'1C000000 + H'20000000 × n to H'1FFFFFFF + H'20000000 × n		n = 0–7

- Notes:
1. Memory with interface such as SRAM or ROM.
 2. Use external pin to specify memory bus width.
 3. Use register to specify memory bus width.
 4. With synchronous DRAM interfaces, bus width must be 16 or 32 bits.
 5. With PCMCIA interface, bus width must be 8 or 16 bits.
 6. Do not access the reserved area. If the reserved area is accessed, correct operation cannot be guaranteed.
 7. When the control register in area 1 is not used for address translation by the MMU, set the first three bits of the logical address to 101 for allocation to the P2 space.

Area 0: H'00000000	Ordinary memory/ burst ROM	
Area 1: H'04000000	Internal I/O	
Area 2: H'08000000	Ordinary memory/ synchronous DRAM	
Area 3: H'0C000000	Ordinary memory/ synchronous DRAM	
Area 4: H'10000000	Ordinary memory	
Area 5: H'14000000	Ordinary memory/ burst ROM/PCMCIA	The PCMCIA interface is shared by the memory and I/O card
Area 6: H'18000000	Ordinary memory/ burst ROM/PCMCIA	The PCMCIA interface is shared by the memory and I/O card

Figure 10.3 Physical Space Allocation

Memory Bus Width: The memory bus width in the SH7709S can be set for each area. In area 0, external pins can be used to select byte (8 bits), word (16 bits), or longword (32 bits) on power-on reset. The correspondence between the external pins (MD4 and MD3) and the memory size is shown in table below.

Table 10.4 Correspondence between External Pins (MD4 and MD3) and Memory Size

MD4	MD3	Memory Size
0	0	Reserved (Do not set)
0	1	8 bits
1	0	16 bits
1	1	32 bits

For areas 2–6, byte, word, and longword can be chosen for the bus width using bus control register 2 (BCR2) whenever ordinary memory, ROM, or burst ROM are used. When the synchronous DRAM interface is used, word or longword can be chosen as the bus width.

When the PCMCIA interface is used, set the bus width to byte or word. When synchronous DRAM is connected to both area 2 and area 3, set the same bus width for areas 2 and 3. When using the port function, set each of the bus widths to byte or word for all areas. For more information, see section 10.2.2, Bus Control Register 2 (BCR2).

Shadow Space: Areas 0 and 2–6 are decoded by physical addresses A28–A26, which correspond to areas 000 to 110. Address bits 31–29 are ignored. This means that the range of area 0 addresses, for example, is H'00000000 to H'03FFFFFF, and its corresponding shadow space is the address space obtained by adding to it H'20000000 × n (n = 1–6). The address range for area 7, which is on-chip I/O space, is H'1C000000 to H'1FFFFFFF. The address space H'1C000000 + H'20000000 × n–H'1FFFFFFF + H'20000000 × n (n = 0–7) corresponding to the area 7 shadow space is reserved, and must not be used.

10.1.6 PCMCIA Support

The SH7709S supports PCMCIA standard interface specifications in physical space areas 5 and 6.

The interfaces supported are basically the “IC memory card interface” and “I/O card interface” stipulated in JEIDA Specifications Ver. 4.2 (PCMCIA2.1).

Table 10.5 PCMCIA Interface Characteristics

Item	Feature
Access	Random access
Data bus	8/16 bits
Memory type	Mask ROM, OTPROM, EPROM, EEPROM, flash memory, SRAM
Memory capacity	Maximum 32 Mbytes
I/O space capacity	Maximum 32 Mbytes
Other features	Dynamic bus sizing of I/O bus width* The PCMCIA interface can be accessed from the address translation area or non-address translation area.

Note: * Dynamic bus sizing of the I/O bus width is supported only in little-endian mode.

Area 5: H'14000000	Common memory/Attribute memory
Area 5: H'16000000	I/O space
Area 6: H'18000000	Common memory/Attribute memory
Area 6: H'1A000000	I/O space

Figure 10.4 PCMCIA Space Allocation

Table 10.6 PCMCIA Support Interface

Pin	IC Memory Card Interface			I/O Card Interface			SH7709S Pin
	Signal	I/O	Function	Signal	I/O	Function	
1	GND	—	Ground	GND	—	Ground	—
2	D3	I/O	Data	D3	I/O	Data	D3
3	D4	I/O	Data	D4	I/O	Data	D4
4	D5	I/O	Data	D5	I/O	Data	D5
5	D6	I/O	Data	D6	I/O	Data	D6
6	D7	I/O	Data	D7	I/O	Data	D7
7	$\overline{CE1}$	I	Card enable	$\overline{CE1}$	I	Card enable	$\overline{CE1A}$ or $\overline{CE1B}$
8	A10	I	Address	A10	I	Address	A10
9	OE	I	Output enable	\overline{OE}	I	Output enable	\overline{RD}
10	A11	I	Address	A11	I	Address	A11
11	A9	I	Address	A9	I	Address	A9
12	A8	I	Address	A8	I	Address	A8
13	A13	I	Address	A13	I	Address	A13
14	A14	I	Address	A14	I	Address	A14
15	$\overline{WE/PGM}$	I	Write enable	$\overline{WE/PGM}$	I	Write enable	\overline{WE}
16	$\overline{RDY/BSY}$	O	Ready/Busy	\overline{IREQ}	O	Ready/Busy	—
17	V_{CC}		Operation power	V_{CC}		Operation power	—
18	VPP1		Program power	VPP1		Program/ peripheral power	—
19	A16	I	Address	A16	I	Address	A16
20	A15	I	Address	A15	I	Address	A15
21	A12	I	Address	A12	I	Address	A12
22	A7	I	Address	A7	I	Address	A7
23	A6	I	Address	A6	I	Address	A6
24	A5	I	Address	A5	I	Address	A5
25	A4	I	Address	A4	I	Address	A4
26	A3	I	Address	A3	I	Address	A3
27	A2	I	Address	A2	I	Address	A2
28	A1	I	Address	A1	I	Address	A1
29	A0	I	Address	A0	I	Address	A0
30	D0	I/O	Data	D0	I/O	Data	D0

Pin	IC Memory Card Interface			I/O Card Interface			SH7709S Pin
	Signal	I/O	Function	Signal	I/O	Function	
31	D1	I/O	Data	D1	I/O	Data	D1
32	D2	I/O	Data	D2	I/O	Data	D2
33	WP	O	Write protect	$\overline{\text{IOIS16}}$	O	16-bit I/O port	$\overline{\text{IOIS16}}$
34	GND		Ground	GND		Ground	—
35	GND		Ground	GND		Ground	—
36	$\overline{\text{CD1}}$	O	Card detection	$\overline{\text{CD1}}$	O	Card detection	—
37	D11	I/O	Data	D11	I/O	Data	D11
38	D12	I/O	Data	D12	I/O	Data	D12
39	D13	I/O	Data	D13	I/O	Data	D13
40	D14	I/O	Data	D14	I/O	Data	D14
41	D15	I/O	Data	D15	I/O	Data	D15
42	$\overline{\text{CE2}}$	I	Card enable	$\overline{\text{CE2}}$	I	Card enable	$\overline{\text{CE2A}}$ or $\overline{\text{CE2B}}$
43	$\overline{\text{VS1}}$	I	Voltage sense 1	$\overline{\text{VS1}}$	I	Voltage sense 1	—
44	RFU		Reserved	$\overline{\text{IORD}}$	I	I/O read	$\overline{\text{ICIORD}}$
45	RFU		Reserved	$\overline{\text{IOWR}}$	I	I/O write	$\overline{\text{ICIOWR}}$
46	A17	I	Address	A17	I	Address	A17
47	A18	I	Address	A18	I	Address	A18
48	A19	I	Address	A19	I	Address	A19
49	A20	I	Address	A20	I	Address	A20
50	A21	I	Address	A21	I	Address	A21
51	V _{CC}		Power supply	V _{CC}		Power supply	—
52	VPP2		Program power	VPP2		Program/ peripheral power	—
53	A22	I	Address	A22	I	Address	A22
54	A23	I	Address	A23	I	Address	A23
55	A24	I	Address	A24	I	Address	A24
56	A25	I	Address	A25	I	Address	A25
57	$\overline{\text{VS2}}$	I	Voltage sense 2	$\overline{\text{VS2}}$	I	Voltage sense 2	—
58	RESET	I	Reset	RESET	I	Reset	—
59	$\overline{\text{WAIT}}$	O	Wait request	$\overline{\text{WAIT}}$	O	Wait request	—
60	RFU		Reserved	$\overline{\text{INPACK}}$	O	Input acknowledge	—

Pin	IC Memory Card Interface			I/O Card Interface			SH7709S Pin
	Signal	I/O	Function	Signal	I/O	Function	
61	$\overline{\text{REG}}$	I	Attribute memory space select	$\overline{\text{REG}}$	I	Attribute memory space select	—
62	BVD2	O	Battery voltage detection	$\overline{\text{SPKR}}$	O	Digital voice signal	—
63	BVD1	O	Battery voltage detection	$\overline{\text{STSCHG}}$	O	Card state change	—
64	D8	I/O	Data	D8	I/O	Data	D8
65	D9	I/O	Data	D9	I/O	Data	D9
66	D10	I/O	Data	D10	I/O	Data	D10
67	$\overline{\text{CD2}}$	O	Card detection	$\overline{\text{CD2}}$	O	Card detection	—
68	GND		Ground	GND		Ground	—

10.2 BSC Registers

10.2.1 Bus Control Register 1 (BCR1)

Bus control register 1 (BCR1) is a 16-bit readable/writable register that sets the functions and bus cycle state for each area. It is initialized to H'0000 by a power-on reset, but is not initialized by a manual reset or in standby mode. Do not access external memory outside area 0 until BCR1 register initialization is complete.

Bit:	15	14	13	12	11	10	9	8
	PULA	PULD	HIZMEM	HIZCNT	ENDIAN	A0BST1	A0BST0	A5BST1
Initial value:	0	0	0	0	0/1*	0	0	0
R/W:	R/W	R/W	R/W	R/W	R	R/W	R/W	R/W
Bit:	7	6	5	4	3	2	1	0
	A5BST0	A6BST1	A6BST0	DRAM TP2	DRAM TP1	DRAM TP0	A5 PCM	A6 PCM
Initial value:	0	0	0	0	0	0	0	0
R/W:	R/W	R/W	R/W	R/W	R/W	R/W	R/W	R/W

Note: * Samples the value of the external pin (MD5) designating the endian in a power-on reset.

Bit 15—Pin A25 to A0 Pull-Up (PULA): Specifies whether or not pins A25 to A0 are pulled up for 4 cycles immediately after $\overline{\text{BACK}}$ is asserted.

Bit 15: PULA	Description
0	Not pulled up (Initial value)
1	Pulled up

Bit 14—Pin D31 to D0 Pull-Up (PULD): Specifies whether or not pins D31 to D0 are pulled up when not in use.

Bit 14: PULD	Description
0	Not pulled up (Initial value)
1	Pulled up

Bit 13—Hi-Z Memory Control (HIZMEM): Specifies the state of A25–A0, $\overline{\text{BS}}$, $\overline{\text{CS}}$, $\overline{\text{RD}}$ / $\overline{\text{WR}}$, $\overline{\text{WE}}$ / $\overline{\text{DQM}}$, $\overline{\text{RD}}$, $\overline{\text{CE2A}}$, $\overline{\text{CE2B}}$ and DRAK0/1 in standby mode.

Bit 13: HIZMEM	Description
0	A25–A0, BS, CS, RD/WR, WE/DQM, RD, CE2A, CE2B and DRAK0/1 are Hi-Z in standby mode (Initial value)
1	A25–A0, BS, CS, RD/WR, WE/DQM, RD, CE2A, CE2B and DRAK0/1 are high in standby mode

Bit 12—High-Z Control (HIZCNT): Specifies the state of the $\overline{\text{RAS}}$ and $\overline{\text{CAS}}$ signals in standby mode and when the bus is released.

Bit 12: HIZCNT	Description
0	$\overline{\text{RAS}}$ and $\overline{\text{CAS}}$ signals are high-impedance (High-Z) in standby mode and when bus is released (Initial value)
1	$\overline{\text{RAS}}$ and $\overline{\text{CAS}}$ signals are driven in standby mode and when bus is released

Bit 11—Endian Flag (ENDIAN): Samples the value of the external pin designating the endian in a power-on reset. The endian for all physical spaces is decided by this bit, which is read-only.

Bit 11: ENDIAN	Description
0	(On reset) Endian setting external pin (MD5) is low. Indicates the SH7709S is set as big-endian
1	(On reset) Endian setting external pin (MD5) is high. Indicates the SH7709S is set as little-endian

Bits 10 and 9—Area 0 Burst ROM Control (A0BST1, A0BST0): Specify whether to use burst ROM in physical space area 0. When burst ROM is used, these bits set the number of burst transfers.

Bit 10: A0BST1	Bit 9: A0BST0	Description
0	0	Access area 0 accessed as ordinary memory (Initial value)
	1	Access area 0 accessed as burst ROM (4 consecutive accesses). Can be used when bus width is 8, 16, or 32.
1	0	Access area 0 accessed as burst ROM (8 consecutive accesses). Can be used when bus width is 8 or 16. Should not be specified when bus width is 16 or 32.
	1	Access area 0 accessed as burst ROM (16 consecutive accesses). Can be used only when bus width is 8. Should not be specified when bus width is 16 or 32.

Bits 8 and 7—Area 5 Burst Enable (A5BST1, A5BST0): Specify whether to use burst ROM and PCMCIA burst mode in physical space area 5. When burst ROM and PCMCIA burst mode are used, these bits set the number of burst transfers.

Bit 8: A5BST1	Bit 7: A5BST0	Description
0	0	Access area 5 accessed as ordinary memory (Initial value)
	1	Burst access of area 5 (4 consecutive accesses). Can be used when bus width is 8, 16, or 32.
1	0	Burst access of area 5 (8 consecutive accesses). Can be used when bus width is 8 or 16. Should not be specified when bus width is 32.
	1	Burst access of area 5 (16 consecutive accesses). Can be used only when bus width is 8. Should not be specified when bus width is 16 or 32.

Bits 6 and 5—Area 6 Burst Enable (A6BST1, A6BST0): Specify whether to use burst ROM and PCMCIA burst mode in physical space area 6. When burst ROM and PCMCIA burst mode are used, these bits set the number of burst transfers.

Bit 6: A6BST1	Bit 5: A6BST0	Description
0	0	Access area 6 accessed as ordinary memory (initial value)
	1	Burst access of area 6 (4 consecutive accesses). Can be used when bus width is 8, 16, or 32.
1	0	Burst access of area 6 (8 consecutive accesses). Can be used when bus width is 8 or 16. Should not be specified when bus width is 32.
	1	Burst access of area 6 (16 consecutive accesses). Can be used only when bus width is 8. Should not be specified when bus width is 16 or 32.

Bits 4 to 2—Area 2, Area 3 Memory Type (DRAMTP2, DRAMTP1, DRAMTP0): Designate the types of memory connected to physical space areas 2 and 3. Ordinary memory, such as ROM, SRAM, or flash ROM, can be directly connected. Synchronous DRAM can also be directly connected.

Bit 4: DRAMTP2	Bit 3: DRAMTP1	Bit 2: DRAMTP0	Description
0	0	0	Areas 2 and 3 are ordinary memory (Initial value)
		1	Reserved (Setting prohibited)
	1	0	Area 2: ordinary memory; area 3: synchronous DRAM*2
		1	Areas 2 and 3 are synchronous DRAM*1*2
1	0	0	Reserved (Setting prohibited)
		1	Reserved (Setting prohibited)
	1	0	Reserved (Setting prohibited)
		1	Reserved (Setting prohibited)

Notes: 1. When selecting this mode, set the same bus width for area 2 and area 3.

2. Do not access synchronous DRAM when clock ratio $\phi:B\phi = 1:1$

Bit 1—Area 5 Bus Type (A5PCM): Designates whether to access physical space area 5 as PCMCIA space.

Bit 1: A5PCM	Description
0	Physical space area 5 accessed as ordinary memory (Initial value)
1	Physical space area 5 accessed as PCMCIA space

Bit 0—Area 6 Bus Type (A6PCM): Designates whether to access physical space area 6 as PCMCIA space.

Bit 0: A6PCM	Description
0	Physical space area 6 accessed as ordinary memory (Initial value)
1	Physical space area 6 accessed as PCMCIA space

10.2.2 Bus Control Register 2 (BCR2)

Bus control register 2 (BCR2) is a 16-bit readable/writable register that selects the bus size of each area and whether an 8-bit port is used or not. It is initialized to H'3FF0 by a power-on reset, but is not initialized by a manual reset or in standby mode. Do not access external memory outside area 0 until BCR2 register initialization is complete.

Bit:	15	14	13	12	11	10	9	8
	—	—	A6SZ1	A6SZ0	A5SZ1	A5SZ0	A4SZ1	A4SZ0
Initial value:	0	0	1	1	1	1	1	1
R/W:	R	R	R/W	R/W	R/W	R/W	R/W	R/W

Bit:	7	6	5	4	3	2	1	0
	A3SZ1	A3SZ0	A2SZ1	A2SZ0	—	—	—	—
Initial value:	1	1	1	1	0	0	0	0
R/W:	R/W	R/W	R/W	R/W	R	R	R	R

Bits 15, 14, 3, 2, 1, and 0—Reserved: These bits are always read as 0. The write value should always be 0.

Bits 2n + 1, 2n—Area n (2–6) Bus Size Specification (AnSZ1, AnSZ0): Specify the bus size of physical space area n (n = 2 to 6).

Bit 2n + 1: AnSZ1	Bit 2n: AnSZ0	Port A / B	Description
0	0	Not used	Reserved (Setting prohibited)
	1		Byte (8-bit) size
1	0	Used	Word (16-bit) size
	1		Longword (32-bit) size
0	0	Used	Reserved (Setting prohibited)
	1		Byte (8-bit) size
1	0	Used	Word (16-bit) size
	1		Reserved (Setting prohibited)

10.2.3 Wait State Control Register 1 (WCR1)

Wait state control register 1 (WCR1) is a 16-bit readable/writable register that specifies the number of idle (wait) state cycles inserted for each area. For some memories, data bus drive may not be turned off quickly even when the read signal from the external device is turned off. This can result in conflicts between data buses when consecutive memory accesses are to different memories or when a write immediately follows a memory read. This LSI automatically inserts the number of idle states set in WCR1 in those cases.

WCR1 is initialized to H'3FF3 by a power-on reset. It is not initialized by a manual reset or in standby mode, and retains its contents.

Bit:	15	14	13	12	11	10	9	8
	WAITSE L	—	A6IW1	A6IW0	A5IW1	A5IW0	A4IW1	A4IW0
Initial value:	0	0	1	1	1	1	1	1
R/W:	R/W	R	R/W	R/W	R/W	R/W	R/W	R/W
Bit:	7	6	5	4	3	2	1	0
	A3IW1	A3IW0	A2IW1	A2IW0	—	—	A0IW1	A0IW0
Initial value:	1	1	1	1	0	0	1	1
R/W:	R/W	R/W	R/W	R/W	R	R	R/W	R/W

Bit 15—WAIT Sampling Timing Select (WAITSEL): Specifies the WAIT signal sampling timing.

Bit 15: WAITSEL	Description
0	Setting to 1 when using the $\overline{\text{WAIT}}$ signal* (Initial value)
1	Sampled $\overline{\text{WAIT}}$ signal at fall of CKIO

Note: * Operation is not guaranteed if $\overline{\text{WAIT}}$ is asserted while WEITSEL = 0.

Bits 14, 3, and 2—Reserved: These bits are always read as 0. The write value should always be 0.

Bits 2n + 1, 2n—Area n (6–2, 0) Intercycle Idle Specification (AnIW1, AnIW0): Specify the number of idles inserted between bus cycles when switching between physical space area n (6–2, 0) and another space or between a read access and a write access in the same physical space.

Bit 2n + 1: AnIW1	Bit 2n: AnIW0	Description
0	0	1 idle cycle inserted
	1	1 idle cycle inserted
1	0	2 idle cycles inserted
	1	3 idle cycles inserted (Initial value)

10.2.4 Wait State Control Register 2 (WCR2)

Wait state control register 2 (WCR2) is a 16-bit readable/writable register that specifies the number of wait state cycles inserted for each area. It also specifies the data access pitch for burst memory accesses. This allows direct connection of even low-speed memories without an external circuit. WCR2 is initialized to H'FFFF by a power-on reset. It is not initialized by a manual reset or in standby mode.

Bit:	15	14	13	12	11	10	9	8
	A6 W2	A6 W1	A6 W0	A5 W2	A5 W1	A5 W0	A4 W2	A4 W1
Initial value:	1	1	1	1	1	1	1	1
R/W:	R/W	R/W	R/W	R/W	R/W	R/W	R/W	R/W

Bit:	7	6	5	4	3	2	1	0
	A4 W0	A3 W1	A3 W0	A2 W1	A2 W0	A0 W2	A0 W1	A0 W0
Initial value:	1	1	1	1	1	1	1	1
R/W:	R/W	R/W	R/W	R/W	R/W	R/W	R/W	R/W

Bits 15 to 13—Area 6 Wait Control (A6W2, A6W1, A6W0): Specify the number of wait states inserted in physical space area 6. Also specify the number of states for burst transfer.

			Description			
Bit 15: A6W2	Bit 14: A6W1	Bit 13: A6W0	First Cycle		Burst Cycle (Excluding First Cycle)	
			Inserted Wait States	$\overline{\text{WAIT}}$ Pin	Number of States Per Data Transfer	$\overline{\text{WAIT}}$ Pin
0	0	0	0	Disabled	2	Enabled
		1	1	Enabled	2	Enabled
	1	0	2	Enabled	3	Enabled
		1	3	Enabled	4	Enabled
1	0	0	4	Enabled	4	Enabled
		1	6	Enabled	6	Enabled
	1	0	8	Enabled	8	Enabled
		1	10 (Initial value)	Enabled	10	Enabled

Bits 12 to 10—Area 5 Wait Control (A5W2, A5W1, A5W0): Specify the number of wait states inserted in physical space area 5. Also specify the number of states for burst transfer.

			Description			
Bit 12: A5W2	Bit 11: A5W1	Bit 10: A5W0	First Cycle		Burst Cycle (Excluding First Cycle)	
			Inserted Wait States	$\overline{\text{WAIT}}$ Pin	Number of States Per Data Transfer	$\overline{\text{WAIT}}$ Pin
0	0	0	0	Disabled	2	Enabled
		1	1	Enabled	2	Enabled
	1	0	2	Enabled	3	Enabled
		1	3	Enabled	4	Enabled
1	0	0	4	Enabled	4	Enabled
		1	6	Enabled	6	Enabled
	1	0	8	Enabled	8	Enabled
		1	10 (Initial value)	Enabled	10	Enabled

Bits 9 to 7—Area 4 Wait Control (A4W2, A4W1, A4W0): Specify the number of wait states inserted in physical space area 4.

Bit 9: A4W2	Bit 8: A4W1	Bit 7: A4W0	Description	
			Inserted Wait State	WAIT Pin
0	0	0	0	Ignored
		1	1	Enabled
	1	0	2	Enabled
		1	3	Enabled
1	0	0	4	Enabled
		1	6	Enabled
	1	0	8	Enabled
		1	10	Enabled (Initial value)

Bits 6 and 5—Area 3 Wait Control (A3W1, A3W0): Specify the number of wait states inserted in physical space area 3.

- For Ordinary Memory

Bit 6: A3W1	Bit 5: A3W0	Description	
		Inserted Wait States	WAIT Pin
0	0	0	Ignored
	1	1	Enabled
1	0	2	Enabled
	1	3	Enabled (Initial value)

- For Synchronous DRAM

Bit 6: A3W1	Bit 5: A3W0	Description	
		Synchronous DRAM: CAS Latency	
0	0	1	
	1	1	
1	0	2	
	1	3	(Initial value)

Bits 4 and 3—Area 2 Wait Control (A2W1, A2W0): Specify the number of wait states inserted in physical space area 2.

- For Ordinary Memory

Bit 4: A2W0	Bit 3: A2W0	Description	
		Inserted Wait States	$\overline{\text{WAIT}}$ Pin
0	0	0	Ignored
	1	1	Enabled
1	0	2	Enabled
	1	3	Enabled (Initial value)

- For Synchronous DRAM

Bit 4: A2W1	Bit 3: A2W0	Description	
		Synchronous DRAM: CAS Latency	
0	0	1	
	1	1	
1	0	2	
	1	3	(Initial value)

Bits 2 to 0—Area 0 Wait Control (A0W2, A0W1, A0W0): Specify the number of wait states inserted in physical space area 0. Also specify the burst pitch for burst transfer.

Bit 2: A0W2	Bit 1: A0W1	Bit 0: A0W0	Description			
			First Cycle		Burst Cycle (Excluding First Cycle)	
			Inserted Wait States	$\overline{\text{WAIT}}$ Pin	Number of States Per Data Transfer	$\overline{\text{WAIT}}$ Pin
0	0	0	0	Ignored	2	Enabled
		1	1	Enabled	2	Enabled
	1	0	2	Enabled	3	Enabled
		1	3	Enabled	4	Enabled
1	0	0	4	Enabled	4	Enabled
		1	6	Enabled	6	Enabled
	1	0	8	Enabled	8	Enabled
		1	10 (Initial value)	Enabled	10	Enabled

10.2.5 Individual Memory Control Register (MCR)

The individual memory control register (MCR) is a 16-bit readable/writable register that specifies RAS and CAS timing for synchronous DRAM (areas 2 and 3), specifies address multiplexing, and controls refresh. This enables direct connection of synchronous DRAM without external circuits.

MCR is initialized to H'0000 by a power-on reset, but is not initialized by a manual reset or in standby mode. Bits TPC1–TPC0, RCD1–RCD0, TRWL1–TRWL0, TRAS1–TRAS0, RASD, and AMX3–AMX0 are written to in the initialization after a power-on reset and should not then be modified again. When RFSH and RMODE are written to, write the same values to the other bits. When using synchronous DRAM, do not access areas 2 and 3 until this register is initialized.

Bit:	15	14	13	12	11	10	9	8
	TPC1	TPC0	RCD1	RCD0	TRWL1	TRWL0	TRAS1	TRAS0
Initial value:	0	0	0	0	0	0	0	0
R/W:	R/W	R/W	R/W	R/W	R/W	R/W	R/W	R/W
Bit:	7	6	5	4	3	2	1	0
	RASD	AMX3	AMX2	AMX1	AMX0	RFSH	RMODE	—
Initial value:	0	0	0	0	0	0	0	0
R/W:	R/W	R/W	R/W	R/W	R/W	R/W	R/W	R

Bits 15 and 14—RAS Precharge Time (TPC1, TPC0): When synchronous DRAM interface is selected as connected memory, they set the minimum number of cycles until output of the next bank-active command after precharge. However, the number of cycles input immediately after the issue of an all-bank-precharge command (PALL) in the case of an auto-refresh or a precharge command (PRE) in the bank active mode is one fewer than the normal value. TPC1 should not be set to 0 and TPC0 to 1 in the bank active mode.

		Description		
Bit 15: TPC1	Bit 14: TPC0	Normal Operation	Immediately after Precharge Command*	Immediately after Self-Refresh
0	0	1 cycle (Initial value)	0 cycle (Initial value)	2 cycles (Initial value)
	1	2 cycles	1 cycle	5 cycles
1	0	3 cycles	2 cycles	8 cycles
	1	4 cycles	3 cycles	11 cycles

Note: * Immediately after all-bank-precharge (PALL) in the case of an auto-refresh or precharge (PRE) in the bank active mode.

Bits 13 and 12—RAS–CAS Delay (RCD1, RCD0): When synchronous DRAM interface is selected as connected memory, these bits set the bank active read/write command delay time.

Bit 13: RCD1	Bit 12: RCD0	Description
0	0	1 cycle (Initial value)
	1	2 cycles
1	0	3 cycles
	1	4 cycles

Bits 11 and 10—Write-Precharge Delay (TRWL1, TRWL0): Set the synchronous DRAM write-precharge delay time. This designates the time between the end of a write cycle and the next bank-active command. This setting is valid only when synchronous DRAM is connected. After the write cycle, the next bank-active command is not issued for the period TPC + TRWL.

Bit 11: TRWL1	Bit 10: TRWL0	Description
0	0	1 cycle (Initial value)
	1	2 cycles
1	0	3 cycles
	1	Reserved (Setting prohibited)

Bits 9 and 8— $\overline{\text{CAS}}$ -Before- $\overline{\text{RAS}}$ Refresh $\overline{\text{RAS}}$ Assert Time (TRAS1, TRAS0): When synchronous DRAM interface is selected, no bank-active command is issued during the period TPC + TRAS after an auto-refresh command.

Bit 9: TRAS1	Bit 8: TRAS0	Description
0	0	2 cycles (Initial value)
	1	3 cycles
1	0	4 cycles
	1	5 cycles

Bit 7—Synchronous DRAM Bank Active (RASD): Specifies whether synchronous DRAM is used in bank active mode or auto-precharge mode. Set auto-precharge mode when areas 2 and 3 are both designated as synchronous DRAM space.

Bit 7: RASD	Description
0	Auto-precharge mode (Initial value)
1	Bank active mode

The bank active mode should not be used unless the bus width for all areas is 32 bits.

Bits 6 to 3—Address Multiplex (AMX3, AMX2, AMX1, AMX0): Specify address multiplexing for synchronous DRAM.

For Synchronous DRAM Interface:

Bit6: AMX3	Bit5: AMX2	Bit 4: AMX1	Bit 3: AMX0	Description
1	1	0	1	The row address begins with A10 (The A10 value is output at A1 when the row address is output. 4M × 16-bit × 4-bank products)
		1	0	The row address begins with A11 (The A11 value is output at A1 when the row address is output. 8M × 16-bit × 4-bank products)*1
0	1	0	0	The row address begins with A9 (The A9 value is output at A1 when the row address is output. 1M × 16-bit × 4-bank products)
			1	The row address begins with A10 (The A10 value is output at A1 when the row address is output. 2M × 8-bit × 4-bank products, 2M × 16-bit × 4-bank products)
		1	1	The row address begins with A9 (The A9 value is output at A1 when the row address is output. 512k × 32-bit × 4-bank products)*2
0	0	0	0	Begin synchronous DRAM access after setting AMX3 to 0 = *1** (Initial value)
Except above value				Reserved (Setting prohibited)

- Notes: 1. Can only be set when using a 16-bit bus width.
2. Can only be set when using a 32-bit bus width.

Bit 2—Refresh Control (RFSH): The RFSH bit determines whether or not synchronous DRAM refresh operations are performed. If the refresh function is not used, the timer for generation of periodic refresh requests can also be used as an interval timer.

Bit 2: RFSH	Description
0	No refresh (Initial value)
1	Refresh

Bit 1—Refresh Mode (RMODE): Selects whether to perform an ordinary refresh or a self-refresh when the RFSH bit is 1. When the RFSH bit is 1 and this bit is 0, an auto-refresh is performed on synchronous DRAM at the period set by refresh-related registers RTCNT, RTCOR, and RTCSR. When a refresh request occurs during an external bus cycle, the refresh cycle is performed after the bus cycle ends. When the RFSH bit is 1 and this bit is also 1, the synchronous DRAM will wait for the end of any executing external bus cycle before going into a self-refresh. All refresh requests to memory that is in the self-refresh state are ignored.

Bit 1: RMODE	Description
0	Auto refresh (RFSH must be 1) (Initial value)
1	Self-refresh (RFSH must be 1)

Bit 0—Reserved: This bit is always read as 0. The write value should always be 0.

10.2.6 PCMCIA Control Register (PCR)

The PCMCIA control register (PCR) is a 16-bit readable/writable register that specifies the assertion and negation timing of the \overline{OE} and \overline{WE} signals for the PCMCIA interface connected to areas 5 and 6. The \overline{OE} and \overline{WE} signal assertion width is set by the wait control bits in the WCR2 register.

PCR is initialized to H'0000 by a power-on reset, but is not initialized, and retains its contents, in a manual reset and in standby mode.

Bit:	15	14	13	12	11	10	9	8
	A6W3	A5W3	—	—	A5TED2	A6TED2	A5TEH2	A6TEH2
Initial value:	0	0	0	0	0	0	0	0
R/W:	R/W	R/W	R/W	R/W	R/W	R/W	R/W	R/W

Bit:	7	6	5	4	3	2	1	0
	A5TED1	A5TED0	A6TED1	A6TED0	A5TEH1	A5TEH0	A6TEH1	A6TEH0
Initial value:	0	0	0	0	0	0	0	0
R/W:	R/W	R/W	R/W	R/W	R/W	R/W	R/W	R/W

Bit 15—Area 6 Wait Control (A6W3): Specifies the number of inserted wait states for area 6 combined with bits A6W2–A6W0 in WCR2. Also specifies the number of transfer states in burst transfer. Clear this bit to 0 when area 6 is not set to PCMCIA.

A6W3	A6W2	A6W1	A6W0	First Cycle		Burst Cycle	
				Inserted Wait States	WAIT Pin	Number of States per One-data Transfer	WAIT Pin
0	0	0	0	0	Ignored	2	Enabled
0	0	0	1	1	Enabled	2	Enabled
0	0	1	0	2	Enabled	3	Enabled
0	0	1	1	3	Enabled	4	Enabled
0	1	0	0	4	Enabled	5	Enabled
0	1	0	1	6	Enabled	7	Enabled
0	1	1	0	8	Enabled	9	Enabled
0	1	1	1	10 (Initial value)	Enabled	11	Enabled
1	0	0	0	12	Enabled	13	Enabled
1	0	0	1	14	Enabled	15	Enabled
1	0	1	0	18	Enabled	19	Enabled
1	0	1	1	22	Enabled	23	Enabled
1	1	0	0	26	Enabled	27	Enabled
1	1	0	1	30	Enabled	31	Enabled
1	1	1	0	34	Enabled	35	Enabled
1	1	1	1	38	Enabled	39	Enabled

Bit 14—Area 5 Wait Control (A5W3): Specifies the number of inserted wait states for area 5 combined with bits A5W2–A5W0 in WCR2. Also specifies the number of transfer states in burst transfer. Clear this bit to 0 when area 5 is not set to PCMCIA.

The relationship between the set value and the number of waits is the same as for A6W3.

Bits 13 and 12—Reserved: These bits are always read as 0. The write value should always be 0.

Bits 11, 7, and 6—Area 5 Address $\overline{OE}/\overline{WE}$ Assert Delay (A5TED2, A5TED1, A5TED0):

Specify the delay time from address output to $\overline{OE}/\overline{WE}$ assertion for the PCMCIA interface connected to area 5.

Bit 11: A5TED2	Bit 7: A5TED1	Bit 6: A5TED0	Description
0	0	0	0.5-cycle delay (Initial value)
		1	1.5-cycle delay
	1	0	2.5-cycle delay
		1	3.5-cycle delay
1	0	0	4.5-cycle delay
		1	5.5-cycle delay
	1	0	6.5-cycle delay
		1	7.5-cycle delay

Bits 10, 5, and 4—Area 6 Address $\overline{OE}/\overline{WE}$ Assert Delay (A6TED2, A6TED1, A6TED0): The A6TED bits specify the delay time from address output to $\overline{OE}/\overline{WE}$ assertion for the PCMCIA interface connected to area 6.

Bit 10: A6TED2	Bit 5: A6TED1	Bit 4: A6TED0	Description
0	0	0	0.5-cycle delay (Initial value)
		1	1.5-cycle delay
	1	0	2.5-cycle delay
		1	3.5-cycle delay
1	0	0	4.5-cycle delay
		1	5.5-cycle delay
	1	0	6.5-cycle delay
		1	7.5-cycle delay

Bits 9, 3, and 2—Area 5 $\overline{OE}/\overline{WE}$ Negate Address Delay (A5TEH2, A5TEH1, A5TEH0):

Specify the address hold delay time from $\overline{OE}/\overline{WE}$ negation for the PCMCIA interface connected to area 5.

Bit 9: A5TEH2	Bit 3: A5TEH1	Bit 2: A5TEH0	Description
0	0	0	0.5-cycle delay (Initial value)
		1	1.5-cycle delay
	1	0	2.5-cycle delay
		1	3.5-cycle delay
1	0	0	4.5-cycle delay
		1	5.5-cycle delay
	1	0	6.5-cycle delay
		1	7.5-cycle delay

Bits 8, 1, and 0—Area 6 $\overline{OE}/\overline{WE}$ Negate Address Delay (A6TEH2, A6TEH1, A6TEH0):

Specify the address hold delay time from $\overline{OE}/\overline{WE}$ negation for the PCMCIA interface connected to area 6.

Bit 8: A6TEH2	Bit 1: A6TEH1	Bit 0: A6TEH0	Description
0	0	0	0.5-cycle delay (Initial value)
		1	1.5-cycle delay
	1	0	2.5-cycle delay
		1	3.5-cycle delay
1	0	0	4.5-cycle delay
		1	5.5-cycle delay
	1	0	6.5-cycle delay
		1	7.5-cycle delay

10.2.7 Synchronous DRAM Mode Register (SDMR)

The synchronous DRAM mode register (SDMR) is an 8-bit write-only register that is written to via the synchronous DRAM address bus. It sets synchronous DRAM mode for areas 2 and 3. SDMR must be set before accessing the synchronous DRAM.

Writes to the synchronous DRAM mode register use the address bus rather than the data bus. If the value to be set is X and the SDMR address is Y, the value X is written in the synchronous DRAM mode register by writing in address X + Y. Since, with a 32-bit bus width, A0 of the synchronous DRAM is connected to A2 of the chip and A1 of the synchronous DRAM is connected to A3 of the chip, the value actually written to the synchronous DRAM is the X value shifted two bits right. With a 16-bit bus width, the value written is the X value shifted one bit right. For example, with a 32-bit bus width, when H'0230 is written to the SDMR register of area 2, random data is written to the address H'FFFD000 (address Y) + H'08C0 (value X), or H'FFFD8C0. As a result, H'0230 is written to the SDMR register. The range for value X is H'0000 to H'0FFC. When H'0230 is written to the SDMR register of area 3, random data is written to the address H'FFFE000 (address Y) + H'08C0 (value X), or H'FFFE8C0. As a result, H'0230 is written to the SDMR register. The range for value X is H'0000 to H'0FFC.

Bit:	31				12	11	10	9	8
	SDMR address								
Initial value:	—	—	—	—	—	—	—	
R/W:	—	—	W*	W*	W	W	W	

Bit:	7	6	5	4	3	2	1	0
	—	—	—	—	—	—	—	—
Initial value:	—	—	—	—	—	—	—	—
R/W:	W	W	W	W	W	W	—	—

Note: * Depending on the type of synchronous DRAM.

10.2.8 Refresh Timer Control/Status Register (RTCSR)

The refresh timer control/status register (RTCSR) is a 16-bit readable/writable register that specifies the refresh cycle, whether to generate an interrupt, and the cycle of that interrupt. It is initialized to H'0000 by a power-on reset, but is not initialized by a manual reset or in standby mode. Make the RTCOR setting before setting bits CKS2 to CKS0 in RTCSR.

Note: The method of writing to RTCSR differs from that for general registers to ensure that RTCSR is not rewritten incorrectly. Use a word transfer instruction to set the upper byte as B'10100101 and the lower byte as the write data. For details, see section 10.2.12, Cautions on Accessing Refresh Control Related Registers.

Bit:	15	14	13	12	11	10	9	8
	—	—	—	—	—	—	—	—
Initial value:	0	0	0	0	0	0	0	0
R/W:	R	R	R	R	R	R	R	R

Bit:	7	6	5	4	3	2	1	0
	CMF	CMIE	CKS2	CKS1	CKS0	OVF	OVIE	LMTS
Initial value:	0	0	0	0	0	0	0	0
R/W:	R/W	R/W	R/W	R/W	R/W	R/W	R/W	R/W

Bits 15 to 8—Reserved: These bits are always read as 0. The write value should always be 0.

Bit 7—Compare Match Flag (CMF): Indicates that the values of RTCNT and RTCOR match.

Bit 7: CMF	Description
0	The values of RTCNT and RTCOR do not match (Initial value) Clearing condition: When a refresh is performed after 0 has been written to CMF and RFSH = 1 and RMODE = 0 (to perform a CBR refresh)
1	The values of RTCNT and RTCOR match Setting condition: RTCNT = RTCOR*

Note: * Contents do not change when 1 is written to CMF.

Bit 6—Compare Match Interrupt Enable (CMIE): Enables or disables an interrupt request caused when CMF in RTCSR is set to 1. Do not set this bit to 1 when using auto-refresh.

Bit 6: CMIE	Description
0	Interrupt request by CMF is disabled (Initial value)
1	Interrupt request by CMF is enabled

Bits 5 to 3—Clock Select Bits (CKS2 to CKS0): Select the clock input to RTCNT. The source clock is the external bus clock (CKIO). The RTCNT count clock is CKIO divided by the specified ratio. RTCOR must be set before setting CKS2-CKS0.

			Description
Bit 5: CKS2	Bit 4: CKS1	Bit 3: CKS0	Normal external bus clock
0	0	0	Clock input disabled
		1	Bus clock (CKIO)/4
	1	0	CKIO/16
		1	CKIO/64
1	0	0	CKIO/256
		1	CKIO/1024
	1	0	CKIO/2048
		1	CKIO/4096

Bit 2—Refresh Count Overflow Flag (OVF): Indicates when the number of refresh requests indicated in the refresh count register (RFCR) exceeds the limit set in the LMTS bit in RTCSR.

Bit 2: OVF	Description
0	RFCR has not exceeded the count limit value set in LMTS (Initial value) Clearing condition: When 0 is written to OVF
1	RFCR has exceeded the count limit value set in LMTS Setting condition: When the RFCR value has exceeded the count limit value set in LMTS*

Note: * Contents do not change when 1 is written to OVF.

Bit 1—Refresh Count Overflow Interrupt Enable (OVIE): Selects whether to suppress generation of interrupt requests by the OVF bit in RTCSR when OVF is set to 1.

Bit 1: OVIE	Description
0	Interrupt request by OVF is disabled (Initial value)
1	Interrupt request by OVF is enabled

Bit 0—Refresh Count Overflow Limit Select (LMTS): Indicates the count limit value to be compared to the number of refreshes indicated in the refresh count register (RFCR). When the value in RFCR overflows the value specified by LMTS, the OVF flag is set.

Bit 0: LMTS	Description
0	Count limit value is 1024 (Initial value)
1	Count limit value is 512

10.2.9 Refresh Timer Counter (RTCNT)

RTCNT is a 16-bit register containing a readable/writable 8-bit counter that counts up on an input clock. The clock select bits (CKS2–CKS0) in RTCSR select the input clock. When RTCNT matches RTCOR, the CMF bit in RTCSR is set and RTCNT is cleared. RTCNT is initialized to H'00 by a power-on reset, but continues incrementing after a manual reset. It is not initialized in standby mode, but holds its contents.

Note: The method of writing to RTCNT differs from that for general registers to ensure that RTCNT is not rewritten incorrectly. Use a word transfer instruction to set the upper byte as B'10100101 and the lower byte as the write data. For details, see section 10.2.12, Cautions on Accessing Refresh Control Related Registers.

Bit:	15	14	13	12	11	10	9	8
Initial value:	0	0	0	0	0	0	0	0
R/W:	—	—	—	—	—	—	—	—
Bit:	7	6	5	4	3	2	1	0
Initial value:	0	0	0	0	0	0	0	0
R/W:	R/W	R/W	R/W	R/W	R/W	R/W	R/W	R/W

10.2.10 Refresh Time Constant Register (RTCOR)

The refresh time constant register (RTCOR) specifies the upper-limit value of RTCNT. The values of RTCOR and RTCNT (lower 8 bits) are constantly compared. When the values match, the compare match flag (CMF) in RTCSR is set and RTCNT is cleared to 0. When the refresh bit (RFSH) in the individual memory control register (MCR) is set to 1 and the refresh mode is set to auto refresh, a memory refresh cycle occurs when the CMF bit is set. RTCOR is a readable/writable register. RTCOR is initialized to H'00 by a power-on reset. It is not initialized by a manual reset or in standby mode, but holds its contents. Make the RTCOR setting before setting bits CKS2 to CKS0 in RTCSR.

Note: The method of writing to RTCOR differs from that for general registers to ensure that RTCOR is not rewritten incorrectly. Use a word transfer instruction to set the upper byte as B'10100101 and the lower byte as the write data. For details, see section 10.2.12, Cautions on Accessing Refresh Control Related Registers.

Bit:	15	14	13	12	11	10	9	8
Initial value:	0	0	0	0	0	0	0	0
R/W:	—	—	—	—	—	—	—	—

Bit:	7	6	5	4	3	2	1	0
Initial value:	0	0	0	0	0	0	0	0
R/W:	R/W	R/W	R/W	R/W	R/W	R/W	R/W	R/W

10.2.11 Refresh Count Register (RFCR)

The refresh count register (RFCR) counts the number of refreshing. When RFCR exceeds the count limit value set in the LMTS bit in RTCSR, the OVF bit in RTCSR is set and RFCR is cleared. RFCR is a 10-bit readable/writable counter. RFCR is initialized to H'0000 by a power-on reset. RFCR continues incrementing in a manual reset. It is not initialized by in standby mode, but holds its contents.

Note: The method of writing to RFCR differs from that for general registers to ensure that RFCR is not rewritten incorrectly. Use a word transfer instruction to set the six bits starting from the MSB in the upper byte as B'101001, and the remaining bits as the write data. For details, see section 10.2.12, Cautions on Accessing Refresh Control Related Registers.

Bit:	15	14	13	12	11	10	9	8
Initial value:	0	0	0	0	0	0	0	0
R/W:	—	—	—	—	—	—	R/W	R/W

Bit:	7	6	5	4	3	2	1	0
Initial value:	0	0	0	0	0	0	0	0
R/W:	R/W	R/W	R/W	R/W	R/W	R/W	R/W	R/W

10.2.12 Cautions on Accessing Refresh Control Related Registers

RFCR, RTCSR, RTCNT, and RTCOR require that a specific code be appended to the data when it is written to prevent data from being mistakenly overwritten by program overruns or other write operations (figure 10.5). Perform reads and writes using the following methods:

1. When writing to RFCR, RTCSR, RTCNT, and RTCOR, use only word transfer instructions. Byte transfer instructions cannot be used.
When writing to RTCNT, RTCSR, or RTCOR, place B'10100101 in the upper byte and the write data in the lower byte. When writing to RFCR, place B'101001 in the upper 6 bits and the write data in the remaining bits, as shown in figure 10.5.
2. When reading from RFCR, RTCSR, RTCNT, and RTCOR, carry out reads with a 16-bit width. 0 is read from undefined bits.

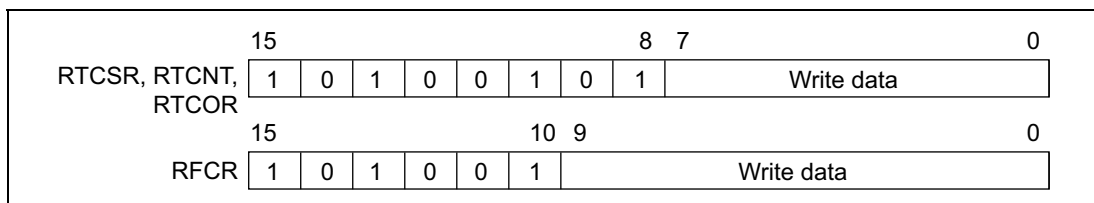

Figure 10.5 Writing to RFCR, RTCSR, RTCNT, and RTCOR

10.2.13 MCS0 Control Register (MCSCR0)

The MCS0 control register (MCSCR0) is a 16-bit readable/writable register that specifies the $\overline{\text{MCS}}[0]$ pin output conditions.

$\overline{\text{MCSCR0}}$ is initialized to H'0000 by a power-on reset, but is not initialized by a manual reset or in standby mode.

As the $\overline{\text{MCS}}[0]$ pin is multiplexed as the PTC0 pin, when using the pin as $\overline{\text{MCS}}[0]$, bits PCOMD[1:0] in the PCCR register should be set to 00 (other function).

Bit:	15	14	13	12	11	10	9	8
	—	—	—	—	—	—	—	—
Initial value:	0	0	0	0	0	0	0	0
R/W:	R	R	R	R	R	R	R	R
Bit:	7	6	5	4	3	2	1	0
	—	CS2/0	CAP1	CAP0	A25	A24	A23	A22
Initial value:	0	0	0	0	0	0	0	0
R/W:	R	R/W	R/W	R/W	R/W	R/W	R/W	R/W

Bits 15 to 7—Reserved: These bits are always read as 0. The write value should always be 0.

Bit 6—CS2/CS0 Select (CS2/0): Selects whether an area 2 or area 0 address is to be decoded.

Bit 6: CS2/0	Description
0	Area 0 is selected
1	Area 2 is selected

Only 0 should be used for the CS2/0 bit in MCSCR0. Either 0 or 1 may be used for MCSCR1 to MCSCR7.

Bits 5 and 4—Connected Memory Size Specification (CAP1, CAP0)

Bit 5: CAP1	Bit 4: CAP0	Description
0	0	32-Mbit memory is connected
0	1	64-Mbit memory is connected
1	0	128-Mbit memory is connected
1	1	256-Mbit memory is connected

Bits 3 to 0—Start Address Specification (A25, A24, A23, A22): These bits specify the start address of the memory area for which $\overline{\text{MCS}}[0]$ is asserted.

10.2.14 MCS1 Control Register (MCSCR1)

The MCS1 control register (MCSCR1) specifies the $\overline{\text{MCS}}[1]$ pin output conditions.

The bit configuration and functions are the same as those of MCSCR0.

10.2.15 MCS2 Control Register (MCSCR2)

The MCS2 control register (MCSCR2) specifies the $\overline{\text{MCS}}[2]$ pin output conditions.

The bit configuration and functions are the same as those of MCSCR0.

10.2.16 MCS3 Control Register (MCSCR3)

The MCS3 control register (MCSCR3) specifies the $\overline{\text{MCS}}[3]$ pin output conditions.

The bit configuration and functions are the same as those of MCSCR0.

10.2.17 MCS4 Control Register (MCSCR4)

The MCS4 control register (MCSCR4) specifies the $\overline{\text{MCS}}[4]$ pin output conditions.

The bit configuration and functions are the same as those of MCSCR0.

10.2.18 MCS5 Control Register (MCSCR5)

The MCS5 control register (MCSCR5) specifies the $\overline{\text{MCS}}[5]$ pin output conditions.

The bit configuration and functions are the same as those of MCSCR0.

10.2.19 MCS6 Control Register (MCSCR6)

The MCS6 control register (MCSCR6) specifies the $\overline{\text{MCS}}[6]$ pin output conditions.

The bit configuration and functions are the same as those of MCSCR0.

10.2.20 MCS7 Control Register (MCSCR7)

The MCS7 control register (MCSCR7) specifies the $\overline{\text{MCS}}[7]$ pin output conditions.

The bit configuration and functions are the same as those of MCSCR0.

10.3 BSC Operation

10.3.1 Endian/Access Size and Data Alignment

The SH7709S supports both big endian, in which the 0 address is the most significant byte in the byte data, and little endian, in which the 0 address is the least significant byte. Switching between the two is designated by an external pin (MD5 pin) at the time of a power-on reset. After a power-on reset, big endian is engaged when MD5 is low; little endian is engaged when MD5 is high.

Three data bus widths are available for ordinary memory (byte, word, longword) and two data bus widths (word and longword) for synchronous DRAM. For the PCMCIA interface, choose from byte and word. This means data alignment is done by matching the device's data width and endian. The access unit must also be matched to the device's bus width. This also means that when longword data is read from a byte-width device, four read operations must be performed. In the SH7709S, data alignment and conversion of data length is performed automatically between the respective interfaces.

Tables 10.7 to 10.12 show the relationship between endian, device data width, and access unit.

Table 10.7 32-Bit External Device/Big-Endian Access and Data Alignment

Operation	Data Bus				Strobe Signals			
	D31–D24	D23–D16	D15–D8	D7–D0	$\overline{WE3}$, DQMUU	$\overline{WE2}$, DQMUL	$\overline{WE1}$, DQMLU	$\overline{WE0}$, DQMLL
Byte access at 0	Data 7–0	—	—	—	Asserted			
Byte access at 1	—	Data 7–0	—	—	Asserted			
Byte access at 2	—	—	Data 7–0	—	Asserted			
Byte access at 3	—	—	—	Data 7–0	Asserted			
Word access at 0	Data 15–8	Data 7–0	—	—	Asserted	Asserted		
Word access at 2	—	—	Data 15–8	Data 7–0			Asserted	Asserted
Longword access at 0	Data 31–24	Data 23–16	Data 15–8	Data 7–0	Asserted	Asserted	Asserted	Asserted

Table 10.8 16-Bit External Device/Big-Endian Access and Data Alignment

Operation		Data Bus				Strobe Signals			
		D31– D24	D23– D16	D15–D8	D7–D0	$\overline{\text{WE}}3$, DQMUU	$\overline{\text{WE}}2$, DQMUL	$\overline{\text{WE}}1$, DQMLU	$\overline{\text{WE}}0$, DQMLL
Byte access at 0		—	—	Data 7–0	—		Asserted	—	
Byte access at 1		—	—	—	Data 7–0			Asserted	
Byte access at 2		—	—	Data 7–0	—		Asserted	—	
Byte access at 3		—	—	—	Data 7–0			Asserted	
Word access at 0		—	—	Data 15–8	Data 7–0		Asserted	Asserted	
Word access at 2		—	—	Data 15–8	Data 7–0		Asserted	Asserted	
Longword access at 0	1st time at 0	—	—	Data 31–24	Data 23–16		Asserted	Asserted	
	2nd time at 2	—	—	Data 15–8	Data 7–0		Asserted	Asserted	

Table 10.9 8-Bit External Device/Big-Endian Access and Data Alignment

Operation	Data Bus				Strobe Signals			
	D31– D24	D23– D16	D15– D8	D7–D0	$\overline{WE3}$, DQMUU	$\overline{WE2}$, DQMUL	$\overline{WE1}$, DQMLU	$\overline{WE0}$, DQMLL
Byte access at 0	—	—	—	Data 7–0				Asserted
Byte access at 1	—	—	—	Data 7–0				Asserted
Byte access at 2	—	—	—	Data 7–0				Asserted
Byte access at 3	—	—	—	Data 7–0				Asserted
Word access at 0	1st time at 0	—	—	Data 15–8				Asserted
	2nd time at 1	—	—	Data 7–0				Asserted
Word access at 2	1st time at 2	—	—	Data 15–8				Asserted
	2nd time at 3	—	—	Data 7–0				Asserted
Longword access at 0	1st time at 0	—	—	Data 31–24				Asserted
	2nd time at 1	—	—	Data 23–16				Asserted
	3rd time at 2	—	—	Data 15–8				Asserted
	4th time at 3	—	—	Data 7–0				Asserted

Table 10.10 32-Bit External Device/Little-Endian Access and Data Alignment

Operation	Data Bus				Strobe Signals			
	D31–D24	D23–D16	D15–D8	D7–D0	WE3, DQMUU	WE2, DQMUL	WE1, DQMLU	WE0, DQMLL
Byte access at 0	—	—	—	Data 7–0				Asserted
Byte access at 1	—	—	Data 7–0	—			Asserted	
Byte access at 2	—	Data 7–0	—	—		Asserted		
Byte access at 3	Data 7–0	—	—	—	Asserted			
Word access at 0	—	—	Data 15–8	Data 7–0			Asserted	Asserted
Word access at 2	Data 15–8	Data 7–0	—	—	Asserted	Asserted		
Longword access at 0	Data 31–24	Data 23–16	Data 15–8	Data 7–0	Asserted	Asserted	Asserted	Asserted

Table 10.11 16-Bit External Device/Little-Endian Access and Data Alignment

Operation	Data Bus				Strobe Signals			
	D31– D24	D23– D16	D15–D8	D7–D0	WE3, DQMUU	WE2, DQMUL	WE1, DQMLU	WE0, DQMLL
Byte access at 0	—	—	—	Data 7–0				Asserted
Byte access at 1	—	—	Data 7–0	—			Asserted	
Byte access at 2	—	—	—	Data 7–0				Asserted
Byte access at 3	—	—	Data 7–0	—			Asserted	
Word access at 0	—	—	Data 15–8	Data 7–0			Asserted	Asserted
Word access at 2	—	—	Data 15–8	Data 7–0			Asserted	Asserted
Longword access at 0	1st time at 0	—	Data 15–8	Data 7–0			Asserted	Asserted
	2nd time at 2	—	Data 31–24	Data 23–16			Asserted	Asserted

Table 10.12 8-Bit External Device/Little-Endian Access and Data Alignment

Operation		Data Bus			Strobe Signals			
		D31– D24	D23– D16	D15–D8 D7–D0	$\overline{WE3}$, DQMUU	$\overline{WE2}$, DQMUL	$\overline{WE1}$, DQMLU	$\overline{WE0}$, DQMLL
Byte access at 0		—	—	Data 7–0				Asserted
Byte access at 1		—	—	Data 7–0				Asserted
Byte access at 2		—	—	Data 7–0				Asserted
Byte access at 3		—	—	Data 7–0				Asserted
Word access at 0	1st time at 0	—	—	Data 7–0				Asserted
	2nd time at 1	—	—	Data 15–8				Asserted
Word access at 2	1st time at 2	—	—	Data 7–0				Asserted
	2nd time at 3	—	—	Data 15–8				Asserted
Longword access at 0	1st time at 0	—	—	Data 7–0				Asserted
	2nd time at 1	—	—	Data 15–8				Asserted
	3rd time at 2	—	—	Data 23–16				Asserted
	4th time at 3	—	—	Data 31–24				Asserted

10.3.2 Description of Areas

Area 0: Area 0 physical address bits A28–A26 are 000. Address bits A31–A29 are ignored and the address range is $H'00000000 + H'20000000 \times n - H'03FFFFFF + H'20000000 \times n$ ($n = 0-6$ and $n = 1-6$ are the shadow spaces).

Ordinary memories such as SRAM, ROM, and burst ROM can be connected to this space. Byte, word, or longword can be selected as the bus width using external pins MD3 and MD4. When the area 0 space is accessed, the $\overline{CS0}$ signal is asserted. The \overline{RD} signal that can be used as \overline{OE} and the $\overline{WE0}$ – $\overline{WE3}$ signals for write control are also asserted. The number of bus cycles is selected between 0 and 10 wait cycles using the A0W2–A0W0 bits in WCR2. When the burst function is used, the bus cycle pitch of the burst cycle is determined within a range of 2–10 according to the number of waits.

Area 1: Area 1 physical address bits A28–A26 are 001. Address bits A31–A29 are ignored and the address range is $H'04000000 + H'20000000 \times n - H'07FFFFFF + H'20000000 \times n$ ($n = 0-6$ and $n = 1-6$ are the shadow spaces).

Area 1 is the area specifically for internal peripheral modules. External memories cannot be connected.

Control registers of the peripheral modules shown below are mapped to this area 1. Their addresses are physical addresses, to which logical addresses can be mapped when the MMU is enabled:

DMAC, PORT, IrDA, SCIF, ADC, DAC, INTC (except INTEVT, IPRA, IPRB)

These registers must be set not to be cached by using software.

Area 2: Area 2 physical address bits A28–A26 are 010. Address bits A31–A29 are ignored and the address range is $H'08000000 + H'20000000 \times n - H'0BFFFFFF + H'20000000 \times n$ ($n = 0-6$ and $n = 1-6$ are the shadow spaces).

Ordinary memories such as SRAM and ROM, as well as synchronous DRAM, can be connected to this space. Byte, word, or longword can be selected as the bus width using bits A2SZ1 and A2SZ0 in BCR2 for ordinary memory.

When the area 2 space is accessed, the $\overline{CS2}$ signal is asserted. When ordinary memories are connected, the \overline{RD} signal that can be used as \overline{OE} and the $\overline{WE0}$ – $\overline{WE3}$ signals for write control are also asserted and the number of bus cycles is selected between 0 and 3 wait cycles using bits A2W1 and A2W0 bits in WCR2. Only when ordinary memories are connected, any way can be inserted in each bus cycle by means of the external wait pin (\overline{WAIT}).

When synchronous DRAM is connected, the $\overline{RAS3U}$ and $\overline{RAS3L}$ signals, \overline{CASU} and \overline{CASL} signals, $\overline{RD/WR}$ signal, and byte control signals DQMHH, DQMHL, DQMLH, and DQMLL are all asserted and addresses multiplexed. Control of $\overline{RAS3U}$, $\overline{RAS3L}$, \overline{CASU} , \overline{CASL} , data timing, and address multiplexing is set with MCR.

Area 3: Area 3 physical address bits A28–A26 are 011. Address bits A31–A29 are ignored and the address range is $H'0C000000 + H'20000000 \times n - H'0FFFFFFF + H'20000000 \times n$ ($n = 0-6$ and $n = 1-6$ are the shadow spaces).

Ordinary memories such as SRAM and ROM, as well as synchronous DRAM, can be connected to this space. Byte, word or longword can be selected as the bus width using bits A3SZ1 and A3SZ0 bits in BCR2 for ordinary memory.

When area 3 space is accessed, $\overline{CS3}$ is asserted.

When ordinary memories are connected, the \overline{RD} signal that can be used as \overline{OE} and the $\overline{WE0}-\overline{WE3}$ signals for write control are asserted and the number of bus cycles is selected between 0 and 3 wait cycles using the A3W1 and A3W0 bits in WCR2.

When synchronous DRAM is connected, the $\overline{RAS3U}$ and $\overline{RAS3L}$ signals, \overline{CASU} and \overline{CASL} signals, RD/\overline{WR} signal, and byte control signals DQMHH, DQMHL, DQMLH, and DQMLL are all asserted and addresses multiplexed.

Area 4: Area 4 physical address bits A28–A26 are 100. Address bits A31–A29 are ignored and the address range is $H'10000000 + H'20000000 \times n - H'13FFFFFFF + H'20000000 \times n$ ($n = 0-6$ and $n = 1-6$ are the shadow spaces).

Only ordinary memories such as SRAM and ROM can be connected to this space. Byte, word, or longword can be selected as the bus width using bits A4SZ1 and A4SZ0 in BCR2. When the area 4 space is accessed, the $\overline{CS4}$ signal is asserted. The \overline{RD} signal that can be used as \overline{OE} and the $\overline{WE0}-\overline{WE3}$ signals for write control are also asserted. The number of bus cycles is selected between 0 and 10 wait cycles using the A4W2–A4W0 bits in WCR2. Any wait can be inserted in each bus cycle by means of the external wait pin (\overline{WAIT}).

Area 5: Area 5 physical address bits A28–A26 are 101. Address bits A31–A29 are ignored and the address range is the 64 Mbytes at $H'14000000 + H'20000000 \times n - H'17FFFFFFF + H'20000000 \times n$ ($n = 0-6$ and $n = 1-6$ are the shadow spaces).

Ordinary memories such as SRAM and ROM as well as burst ROM and PCMCIA interfaces can be connected to this space. When the PCMCIA interface is used, the IC memory card interface address range comprises the 32 Mbytes at $H'14000000 + H'20000000 \times n$ to $H'15FFFFFFF + H'20000000 \times n$ ($n = 0-6$ and $n = 1-6$ are the shadow spaces), and the I/O card interface address range comprises the 32 Mbytes at $H'16000000 + H'20000000 \times n$ to $H'17FFFFFFF + H'20000000 \times n$ ($n = 0-6$ and $n = 1-6$ are the shadow spaces).

For ordinary memory and burst ROM, byte, word, or longword can be selected as the bus width using bits A5SZ1 and A5SZ0 in BCR2. For the PCMCIA interface, byte or word can be selected as the bus width using bits A5SZ1 and A5SZ0 bits in BCR2.

When the area 5 space is accessed and ordinary memory is connected, the $\overline{CS5}$ signal is asserted. The \overline{RD} signal that can be used as \overline{OE} and the $\overline{WE0}$ – $\overline{WE3}$ signals for write control are also asserted. When the PCMCIA interface is used, the $\overline{CE1A}$ signal, $\overline{CE2A}$ signal, \overline{RD} signal as \overline{OE} signal, and $\overline{WE1}$ signal are asserted.

The number of bus cycles is selected between 0 and 10 wait cycles using the A5W2–A5W0 bits in WCR2. With the PCMCIA interface, from 0 to 38 wait cycles can be selected using the A5W2–A5W0 bits in WCR2 and the A5W3 bit in PCR. In addition, any number of waits can be inserted in each bus cycle by means of the external wait pin (\overline{WAIT}). When a burst function is used, the bus cycle pitch of the burst cycle is determined within a range of 2–11 (2–39 for the PCMCIA interface) according to the number of waits. The setup and hold times of address/ $\overline{CS5}$ for the read/write strobe signals can be set in the range 0.5–7.5 using bits A5TED2–A5TED0 and A5TEH2–A5TEH0 in the PCR register.

Area 6: Area 6 physical address bits A28–A26 are 110. Address bits A31–A29 are ignored and the address range is the 64 Mbytes at $H'18000000 + H'20000000 \times n - H'1BFFFFFF + H'20000000 \times n$ ($n = 0$ – 6 and $n = 1$ – 6 are the shadow spaces).

Ordinary memories such as SRAM and ROM as well as burst ROM and PCMCIA interfaces can be connected to this space. When the PCMCIA interface is used, the IC memory card interface address range is 32 Mbytes at $H'18000000 + H'20000000 \times n - H'19FFFFFF + H'20000000 \times n$ and the I/O card interface address range is 32 Mbytes at $H'1A000000 + H'20000000 \times n - H'1BFFFFFF + H'20000000 \times n$ ($n = 0$ – 6 and $n = 1$ – 6 are the shadow spaces).

For ordinary memory and burst ROM, byte, word, or longword can be selected as the bus width using bits A6SZ1 and A6SZ0 in BCR2. For the PCMCIA interface, byte or word can be selected as the bus width using bits A6SZ1 and A6SZ0 in BCR2.

When the area 6 space is accessed and ordinary memory is connected, the $\overline{CS6}$ signal is asserted. The \overline{RD} signal that can be used as \overline{OE} and the $\overline{WE0}$ – $\overline{WE3}$ signals for write control are also asserted. When the PCMCIA interface is used, the $\overline{CE1B}$ signal, $\overline{CE2B}$ signal, \overline{RD} signal as \overline{OE} signal, and \overline{WE} , \overline{ICIORD} , and \overline{ICIOWR} signals are asserted.

The number of bus cycles is selected between 0 and 10 wait cycles using the A6W2–A6W0 bits in WCR2. With the PCMCIA interface, from 0 to 38 wait cycles can be selected using the A6W2–A6W0 bits in WCR2 and the A6W3 bit in PCR. In addition, any number of waits can be inserted in each bus cycle by means of the external wait pin (\overline{WAIT}). The bus cycle pitch of the burst cycle is determined within a range of 2–11 (2–39 for the PCMCIA interface) according to the number of waits. The address/ $\overline{CS6}$ setup and hold times for the read/write strobe signals can be set in the range 0.5–7.5 using bits A6TED2–A6TED0 and A6TEH2–A6TEH0 in the PCR register.

10.3.3 Basic Interface

Basic Timing: The basic interface of the SH7709S uses strobe signal output in consideration of the fact that mainly static RAM will be directly connected. Figure 10.6 shows the basic timing of normal space accesses. A no-wait normal access is completed in two cycles. The \overline{BS} signal is asserted for one cycle to indicate the start of a bus cycle. The \overline{CSn} signal is negated on the T2 clock falling edge to secure the negation period. Therefore, in case of access at minimum pitch, there is a half-cycle negation period.

There is no access size specification when reading. The correct access start address is output in the least significant bit of the address, but since there is no access size specification, 32 bits are always read in case of a 32-bit device, and 16 bits in case of a 16-bit device. When writing, only the \overline{WE} signal for the byte to be written is asserted. For details, see section 10.3.1, Endian/Access Size and Data Alignment.

Read/write for cache fill or write-back follows the set bus width and transfers a total of 16 bytes continuously. The bus is not released during this transfer. For cache misses that occur during byte or word operand accesses or branching to odd word boundaries, the fill is always performed by longword accesses on the chip-external interface. Write-through-area write access and non-cacheable read/write access are based on the actual address size.

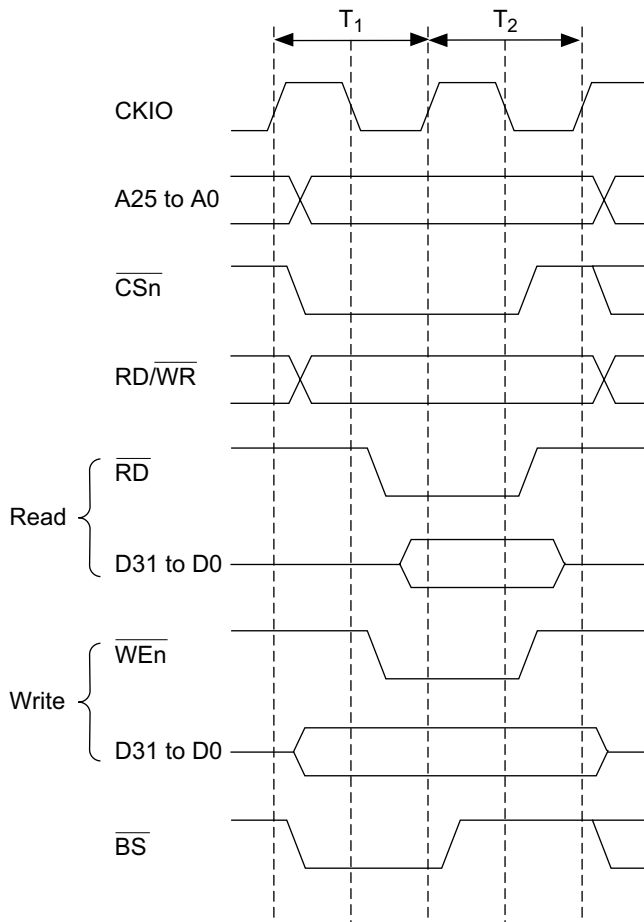

Figure 10.6 Basic Timing of Basic Interface

Figures 10.7, 10.8, and 10.9 show examples of connection to 32-, 16-, and 8-bit data-width static RAM, respectively.

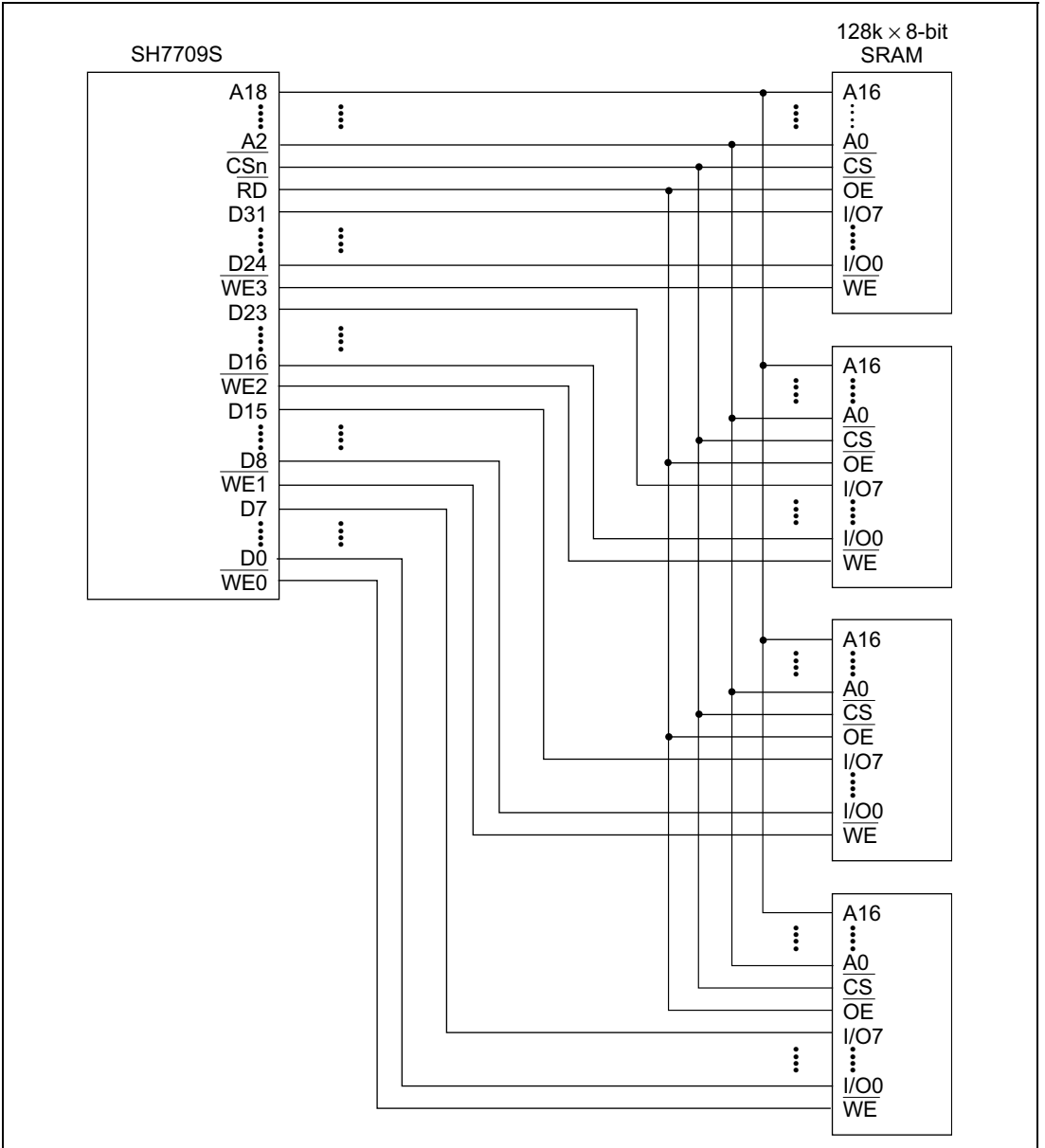

Figure 10.7 Example of 32-Bit Data-Width Static RAM Connection

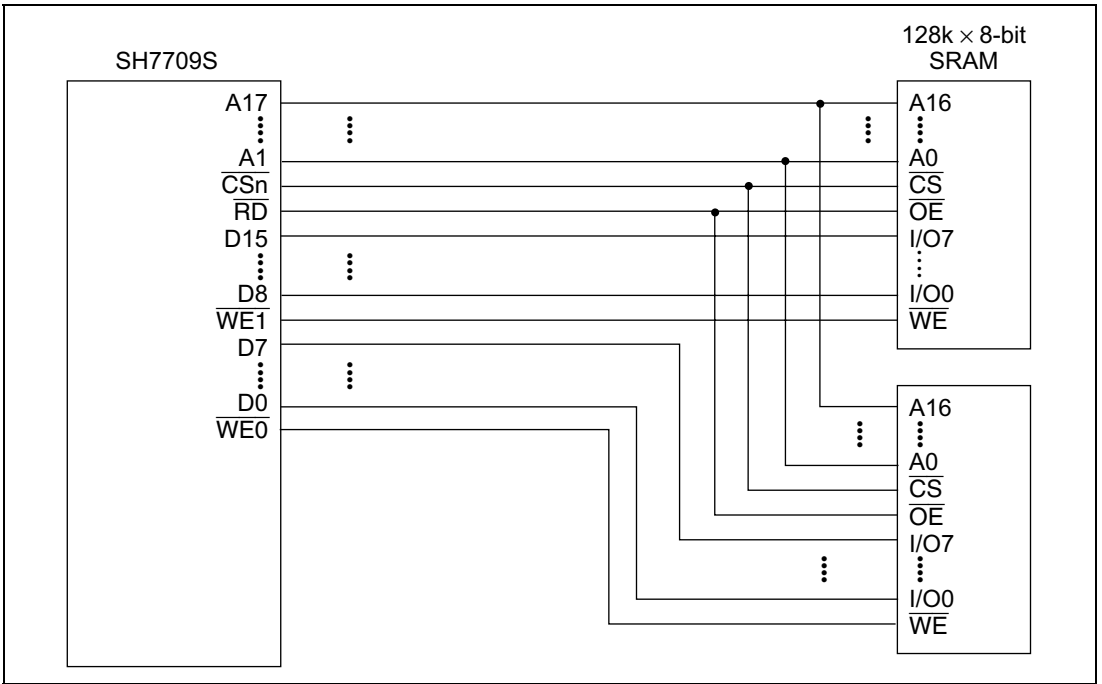

Figure 10.8 Example of 16-Bit Data-Width Static RAM Connection

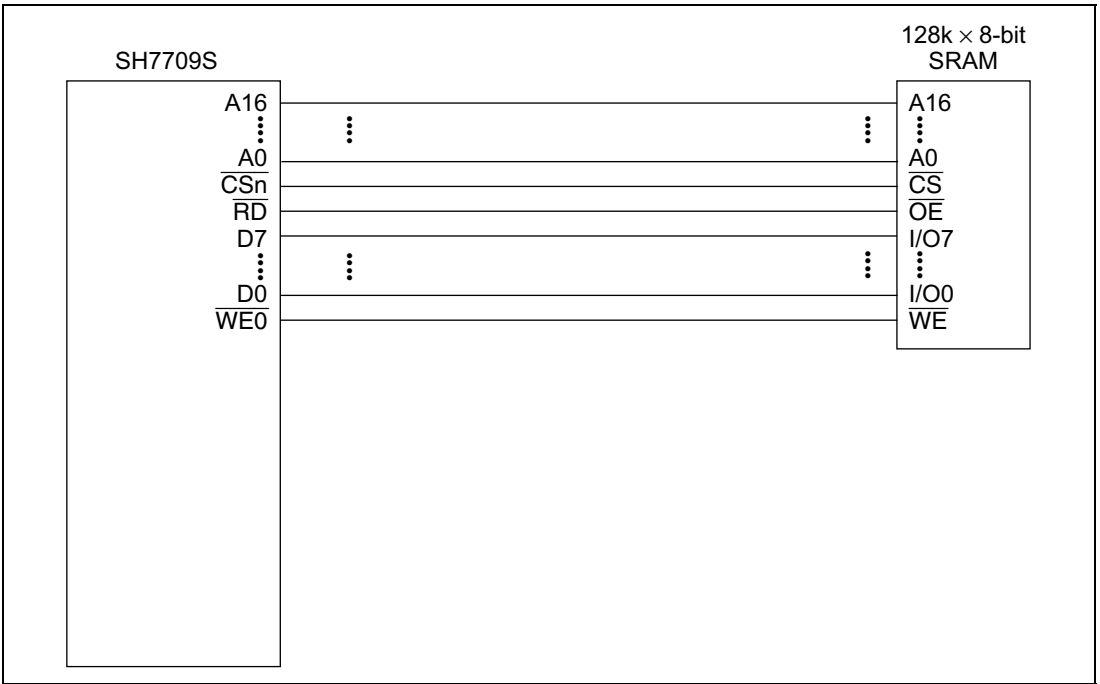

Figure 10.9 Example of 8-Bit Data-Width Static RAM Connection

Wait State Control: Wait state insertion on the basic interface can be controlled by the WCR2 settings. If the WCR2 wait specification bits corresponding to a particular area are not zero, a software wait is inserted in accordance with that specification. For details, see section 10.2.4, Wait State Control Register 2 (WCR2).

The specified number of T_w cycles are inserted as wait cycles using the basic interface wait timing shown in figure 10.10.

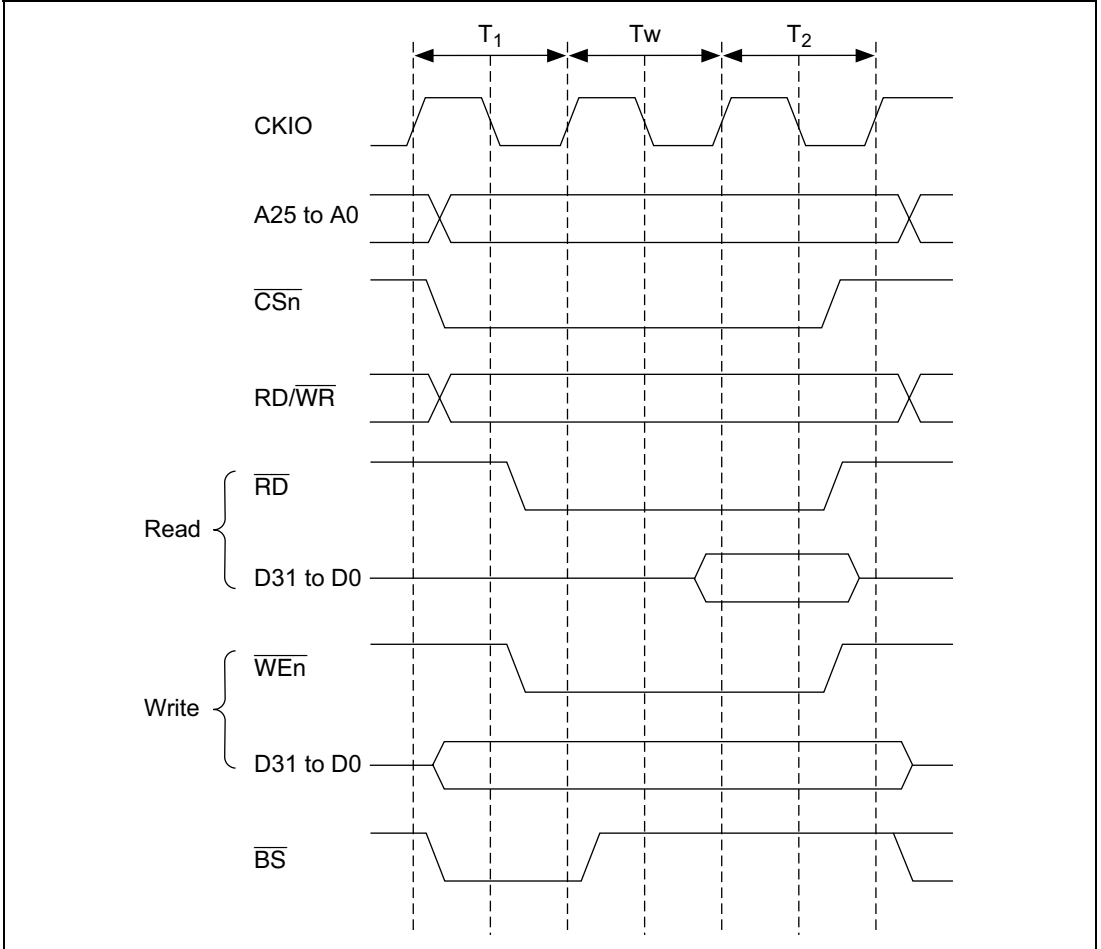

Figure 10.10 Basic Interface Wait Timing (Software Wait Only)

When software wait insertion is specified by WCR2, the external wait input $\overline{\text{WAIT}}$ signal is also sampled. $\overline{\text{WAIT}}$ pin sampling is shown in figure 10.11. A 2-cycle wait is specified as a software wait. Sampling is performed at the transition from the Tw state to the T₂ state; therefore, if the $\overline{\text{WAIT}}$ signal has no effect if asserted in the T₁ cycle or the first Tw cycle.

When the WAITSEL bit in the WCR1 register is set to 1, the $\overline{\text{WAIT}}$ signal is sampled at the falling edge of the clock. If the setup time and hold times with respect to the falling edge of the clock are not satisfied, the value sampled at the next falling edge is used.

However, the $\overline{\text{WAIT}}$ signal is ignored in the following three cases:

- A write to external address space in dual address mode with 16-byte DMA transfer
- Transfer from an external device with DACK to external address space in single address mode with 16-byte DMA transfer
- Cache write-back access

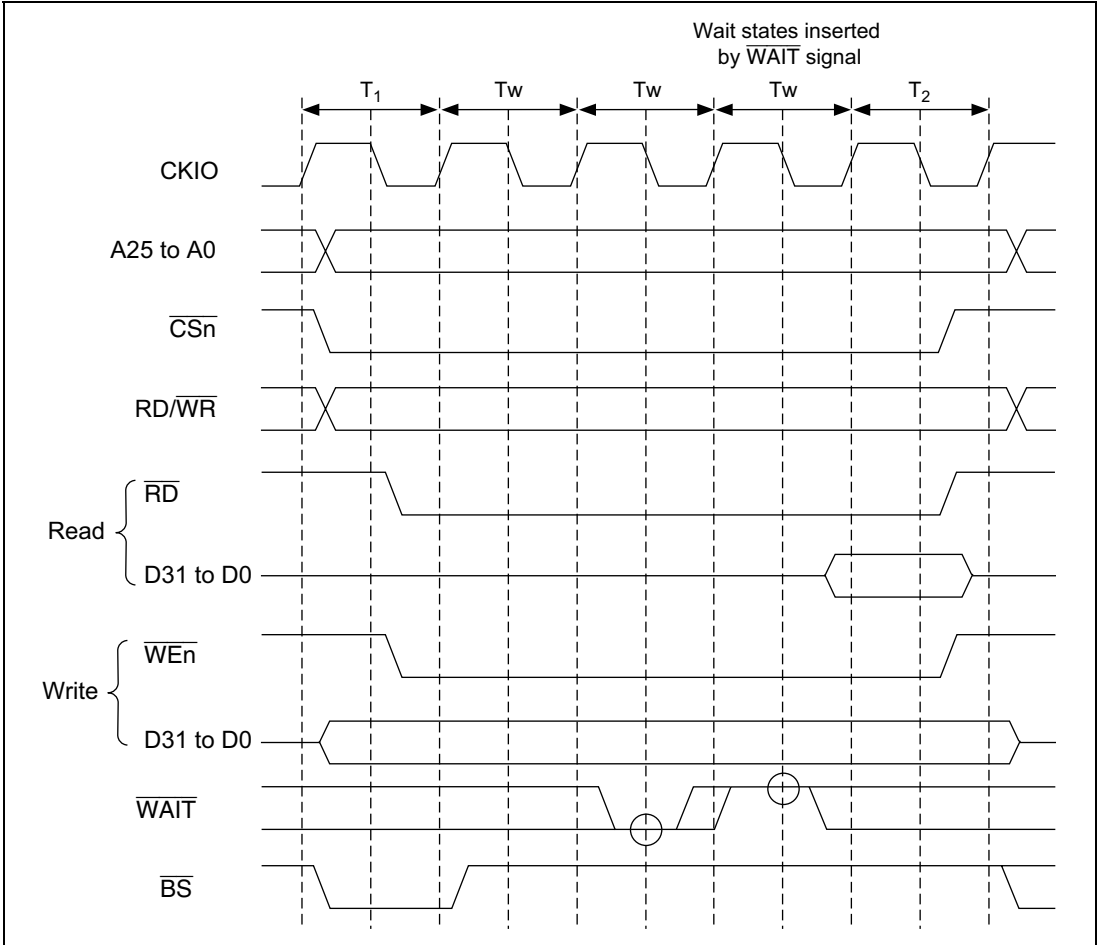

Figure 10.11 Basic Interface Wait State Timing (Wait State Insertion by \overline{WAIT} Signal WAITSEL = 1)

10.3.4 Synchronous DRAM Interface

Synchronous DRAM Direct Connection: Since synchronous DRAM can be selected by the \overline{CS} signal, physical space areas 2 and 3 can be connected using \overline{RAS} and other control signals in common. If the memory type bits (DRAMTP2–0) in BCR1 are set to 010, area 2 is ordinary memory space and area 3 is synchronous DRAM space; if set to 011, areas 2 and 3 are both synchronous DRAM space. Note, however, that synchronous DRAM must not be accessed when clock ratio $I\phi:B\phi = 1:1$.

With the SH7709S, burst length 1 burst read/single write mode is supported as the synchronous DRAM operating mode. A data bus width of 16 or 32 bits can be selected. A 16-bit burst transfer is performed in a cache fill/write-back cycle, and only one access is performed in a write-through area write or a non-cacheable area read/write.

The control signals for direct connection of synchronous DRAM are $\overline{RAS3L}$, $\overline{RAS3U}$, \overline{CASL} , \overline{CASU} , RD/\overline{WR} , $\overline{CS2}$ or $\overline{CS3}$, DQM_{UU} , DQM_{UL} , $DQMLU$, $DQMLL$, and CKE. All the signals other than $\overline{CS2}$ and $\overline{CS3}$ are common to all areas, and signals other than CKE are valid and fetched to the synchronous DRAM only when $\overline{CS2}$ or $\overline{CS3}$ is asserted. Synchronous DRAM can therefore be connected in parallel to a number of areas. CKE is negated (low) only when self-refreshing is performed, and is always asserted (high) at other times.

In the refresh cycle and mode-register write cycle, $\overline{RAS3U}$ and $\overline{RAS3L}$ or \overline{CASU} and \overline{CASL} are output.

Commands for synchronous DRAM are specified by $\overline{RAS3L}$, $\overline{RAS3U}$, \overline{CASL} , \overline{CASU} , RD/\overline{WR} , and special address signals. The commands are NOP, auto-refresh (REF), self-refresh (SELF), precharge all banks (PALL), row address strobe bank active (ACTV), read (READ), read with precharge (READA), write (WRIT), write with precharge (WRITA), and mode register write (MRS).

Byte specification is performed by DQM_{UU} , DQM_{UL} , $DQMLU$, and $DQMLL$. A read/write is performed for the byte for which the corresponding DQM is low. In big-endian mode, DQM_{UU} specifies an access to address $4n$, and $DQMLL$ specifies an access to address $4n + 3$. In little-endian mode, DQM_{UU} specifies an access to address $4n + 3$, and $DQMLL$ specifies an access to address $4n$.

Figures 10.12 and 10.13 show examples of the connection of two $1M \times 16\text{-bit} \times 4\text{-bank}$ synchronous DRAMs and one $1M \times 16\text{-bit} \times 4\text{-bank}$ synchronous DRAM, respectively.

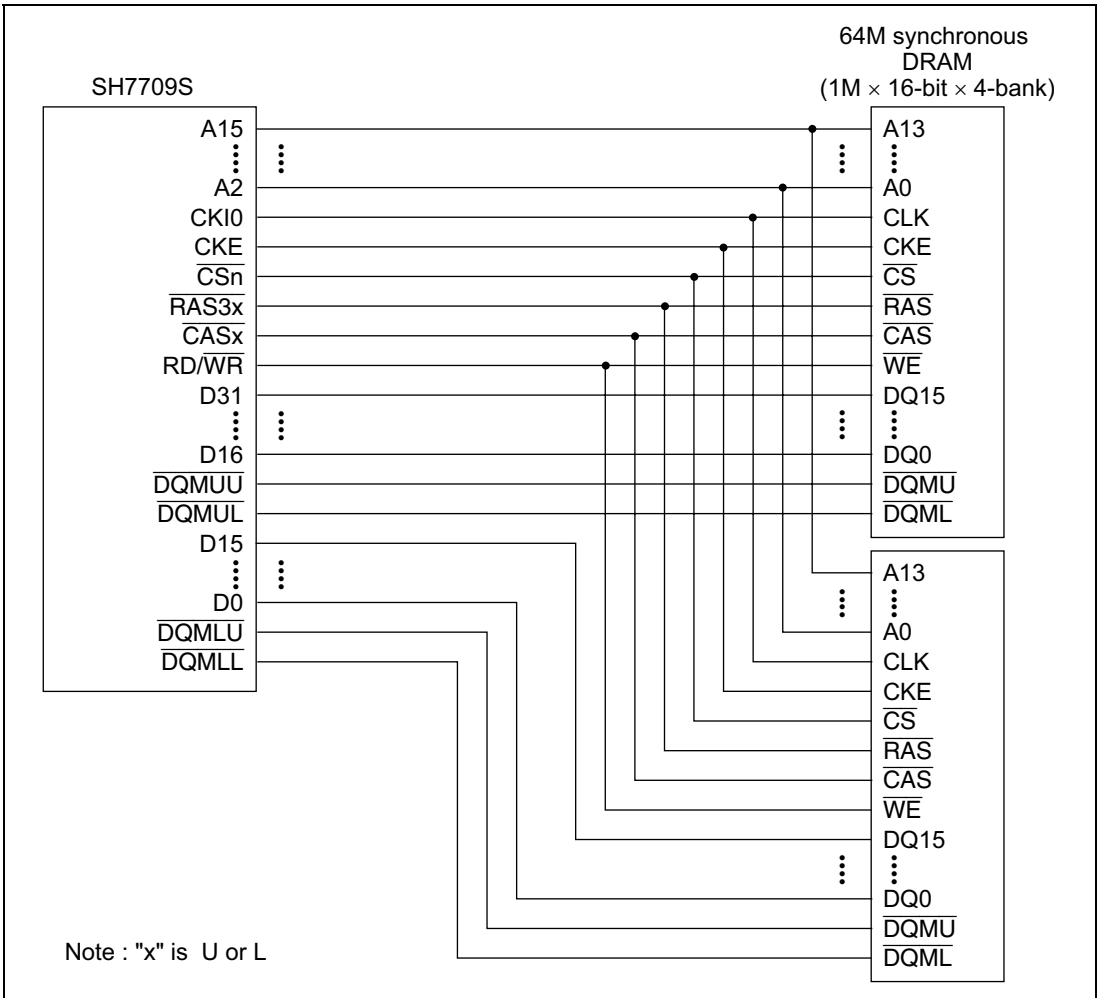

Figure 10.12 Example of 64-Mbit Synchronous DRAM Connection (32-Bit Bus Width)

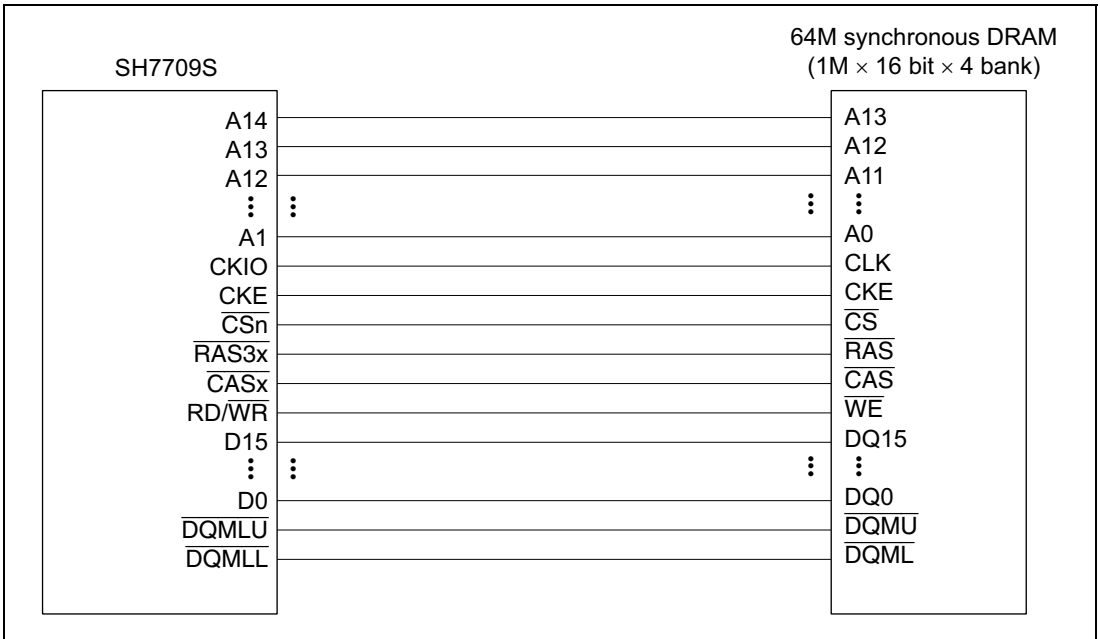

Figure 10.13 Example of 64-Mbit Synchronous DRAM Connection (16-Bit Bus Width)

Address Multiplexing: Synchronous DRAM can be connected without external multiplexing circuitry in accordance with the address multiplex specification bits AMX2-AMX0 in MCR. Table 10.13 shows the relationship between the address multiplex specification bits and the bits output at the address pins.

A25–A17 and A0 are not multiplexed; the original values are always output at these pins.

When A0, the LSB of the synchronous DRAM address, is connected to the SH7709S, it performs longword address specification. Connection should therefore be made in the following order: with a 32-bit bus width, connect pin A0 of the synchronous DRAM to pin A2 of the SH7709S, then connect pin A1 to pin A3; with a 16-bit bus width, connect pin A0 of the synchronous DRAM to pin A1 of the SH7709S, then connect pin A1 to pin A2.

Table 10.13 Relationship between Bus Width, AMX Bits, and Address Multiplex Output

Bus Width	Memory Type	Setting				Output Timing	External Address Pins								
		AMX 3	AMX 2	AMX 1	AMX 0		A1 to A8	A9	A10	A11	A12	A13	A14	A15	A16
32 bits	4M × 16bits × 4banks ^{*1}	1	1	0	1	Column address	A1 to A8	A9	A10	A11	L/H ^{*3}	A13	A23	A24 ^{*4}	A25 ^{*4}
						Row address	A10 to A17	A18	A19	A20	A21	A22	A23	A24 ^{*4}	A25 ^{*4}
	2M × 16bits × 4banks ^{*2}	0	1	0	1	Column address	A1 to A8	A9	A10	A11	L/H ^{*3}	A13	A23 ^{*4}	A24 ^{*4}	
						Row address	A10 to A17	A18	A19	A20	A21	A22	A23 ^{*4}	A24 ^{*4}	
	1M × 16bits × 4banks ^{*2}	0	1	0	0	Column address	A1 to A8	A9	A10	A11	L/H ^{*3}	A13	A22 ^{*4}	A23 ^{*4}	
						Row address	A9 to A16	A17	A18	A19	A20	A21	A22 ^{*4}	A23 ^{*4}	
	2M × 8bits × 4banks ^{*2}	0	1	0	1	Column address	A1 to A8	A9	A10	A11	L/H ^{*3}	A13	A23 ^{*4}	A24 ^{*4}	
						Row address	A10 to A17	A18	A19	A20	A21	A22	A23 ^{*4}	A24 ^{*4}	
	512k × 32bits × 4banks ^{*2}	0	1	1	1	Column address	A1 to A8	A9	A10	A11	L/H ^{*3}	A12	A21 ^{*4}	A22 ^{*4}	A15
						Row address	A9 to A16	A17	A18	A19	A20	A21 ^{*4}	A22 ^{*4}	A23	
16 bits	8M × 16bits × 4banks ^{*1}	1	1	1	0	Column address	A1 to A8	A9	A10	L/H ^{*3}	A12	A23	A24 ^{*4}	A25 ^{*4}	
						Row address	A11 to A18	A19	A20	A21	A22	A23	A24 ^{*4}	A25 ^{*4}	
	4M × 16bits × 4banks ^{*2}	1	1	0	1	Column address	A1 to A8	A9	A10	L/H ^{*3}	A12	A22	A23 ^{*4}	A24 ^{*4}	
						Row address	A10 to A17	A18	A19	A20	A21	A22	A23 ^{*4}	A24 ^{*4}	

Bus Width	Memory Type	Setting				Output Timing	External Address Pins							
		AMX 3	AMX 2	AMX 1	AMX 0		A1 to A8	A9	A10	A11	A12	A13	A14	A15
2M × 16bits × 4banks ^{*2}	0	1	0	1	Column address	A1 to A8	A9	A10	L/H ^{*3}	A12	A22 ^{*4}	A23 ^{*4}	A24	
						Row address	A10 to A17	A18	A19	A20	A21	A22 ^{*4}	A23 ^{*4}	A24
1M × 16bits × 4banks ^{*2}	0	1	0	0	Column address	A1 to A8	A9	A10	L/H ^{*3}	A12	A21 ^{*4}	A22 ^{*4}	A15	
						Row address	A 9 to A17	A18	A19	A20	A21 ^{*4}	A22 ^{*4}	A23	
2M × 8bits × 4banks ^{*2}	0	1	0	1	Column address	A1 to A8	A9	A10	L/H ^{*3}	A12	A22 ^{*4}	A23 ^{*4}	A24	
						Row address	A10 to A18	A19	A20	A21	A22 ^{*4}	A23 ^{*4}	A24	

- Notes:
1. Only RAL3L or CASL is output.
 2. When addresses are upper 32 Mbytes, $\overline{\text{RAS3U}}$ or $\overline{\text{CASU}}$ is output.
When addresses are lower 32 Mbytes, $\overline{\text{RAS3L}}$ or $\overline{\text{CASL}}$ is output.
 3. L/H is a bit used in the command specification; it is fixed at L or H according to the access mode.
 4. Bank address specification

Table 10.14 Example of Correspondence between SH7709S and Synchronous DRAM Address Pins (AMX [3:0] = 0100 (32-Bit Bus Width))

SH7709S Address Pin	Synchronous DRAM Address Pin		Function	
	RAS Cycle	CAS Cycle		
A15	A23	A23	A13(BA1)	BANK select bank address
A14	A22	A22	A12(BA0)	
A13	A21	A13	A11	Address
A12	A20	L/H	A10	Address precharge setting
A11	A19	A11	A9	Address
A10	A18	A10	A8	
A9	A17	A9	A7	
A8	A16	A8	A6	
A7	A15	A7	A5	
A6	A14	A6	A4	
A5	A13	A5	A3	
A4	A12	A4	A2	
A3	A11	A3	A1	
A2	A10	A2	A0	
A1	A9	A1	Not used	
A0	A0	A0	Not used	

Burst Read: In the example in figure 10.15 it is assumed that four $2\text{M} \times 8\text{-bit}$ synchronous DRAMs are connected and a 32-bit data width is used, and the burst length is 1. Following the T_r cycle in which ACTV command output is performed, a READ command is issued in the T_{c1} , T_{c2} , and T_{c3} cycles, and a READA command in the T_{c4} cycle, and the read data is accepted at the rising edge of the external command clock (CKIO) from cycle T_{d1} to cycle T_{d4} . The T_{pc} cycle is used to wait for completion of auto-precharge based on the READA command inside the synchronous DRAM; no new access command can be issued to the same bank during this cycle, but access to synchronous DRAM for another area is possible. In the SH7709S, the number of T_{pc} cycles is determined by the TPC bit specification in MCR, and commands cannot be issued for the same synchronous DRAM during this interval.

The example in figure 10.14 shows the basic cycle. To connect low-speed synchronous DRAM, the cycle can be extended by setting WCR2 and MCR bits. The number of cycles from the ACTV command output cycle, T_r , to the READ command output cycle, T_{c1} , can be specified by the RCD bits in MCR, with values of 0 to 3 specifying 1 to 4 cycles, respectively. In case of 2 or more cycles, a T_{rw} cycle, in which an NOP command is issued for the synchronous DRAM, is inserted between the T_r cycle and the T_c cycle. The number of cycles from READ and READA command output cycles T_{c1} - T_{c4} to the first read data latch cycle, T_{d1} , can be specified as 1 to 3 cycles

independently for areas 2 and 3 by means of bits A2W1 and A2W0 or A3W1 and A3W0 in WCR2. This number of cycles corresponds to the number of synchronous DRAM CAS latency cycles.

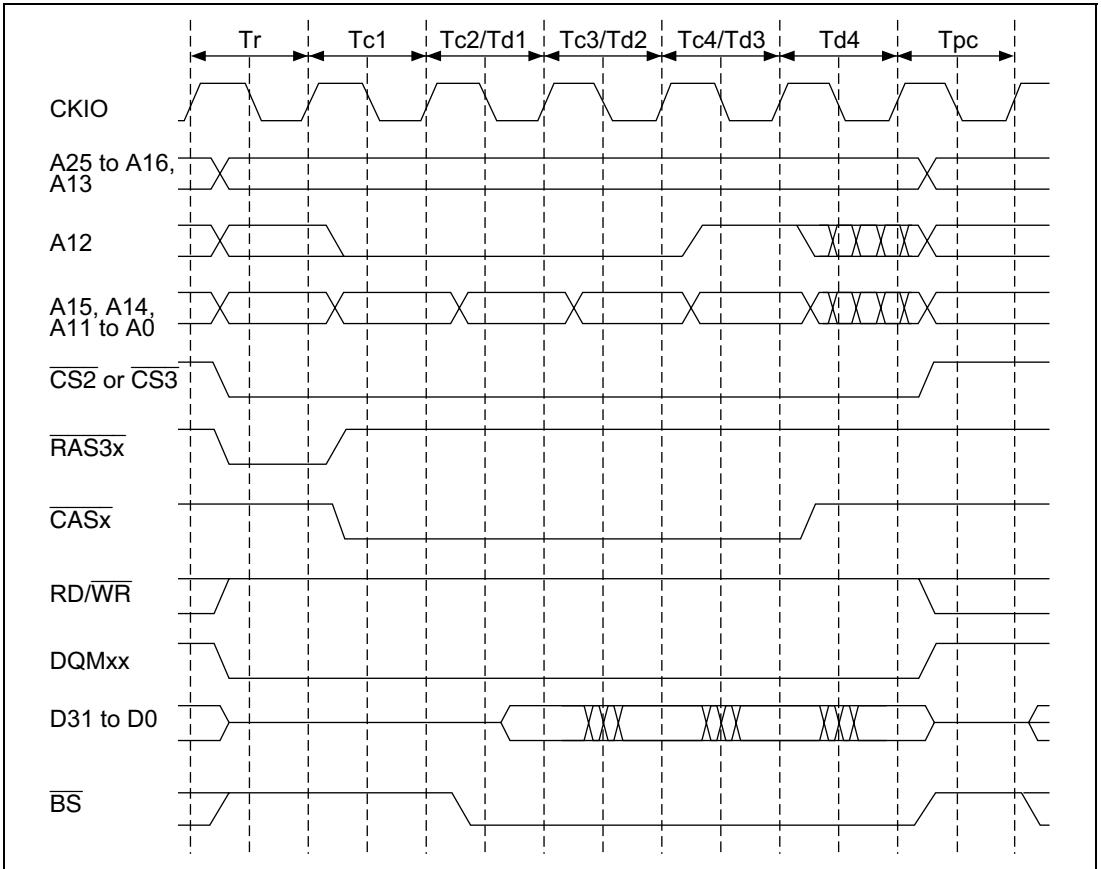

Figure 10.14 Basic Timing for Synchronous DRAM Burst Read

Figure 10.15 shows the burst read timing when RCD is set to 1, A3W1 and A3W0 are set to 10, and TPC is set to 1.

The BS cycle, which is asserted for one cycle at the start of a bus cycle for normal access space, is asserted in each of cycles Td1–Td4 in a synchronous DRAM cycle. When a burst read is performed, the address is updated each time $\overline{\text{CAS}}$ is asserted. As the unit of burst transfer is 16 bytes, address updating is performed for A3 and A2 only (when the bus width is 16 bits, address updating is performed for A3, A2, and A1). The order of access is as follows: in a fill operation in the event of a cache miss, the missed data is read first, then 16-byte boundary data including the missed data is read in wraparound mode.

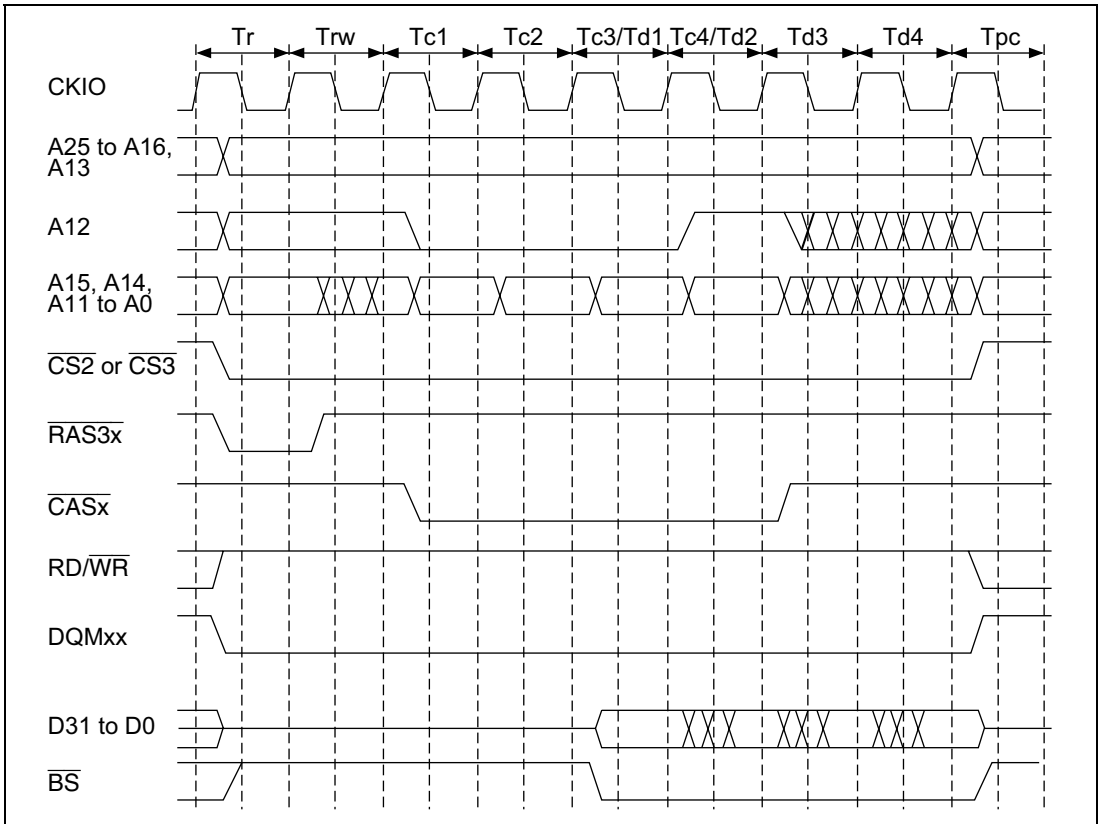

Figure 10.15 Synchronous DRAM Burst Read Wait Specification Timing

Single Read: Figure 10.16 shows the timing when a single address read is performed. As the burst length is set to 1 in synchronous DRAM burst read/single write mode, only the required data is output. Consequently, no unnecessary bus cycles are generated even when a cache-through area is accessed.

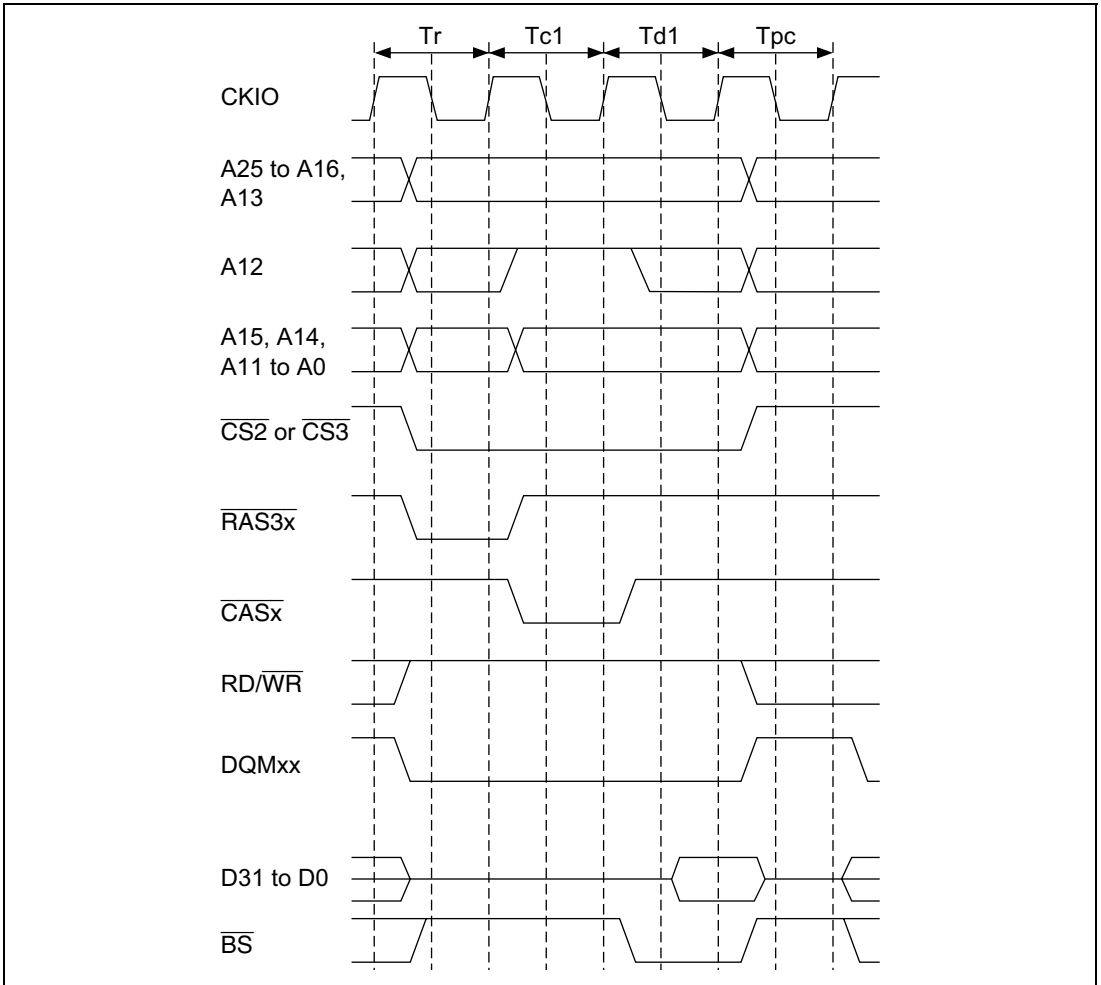

Figure 10.16 Basic Timing for Synchronous DRAM Single Read

Burst Write: The timing chart for a burst write is shown in figure 10.17. In the SH7709S, a burst write occurs only in the event of cache write-back or 16-byte DMAC transfer. In a burst write operation, following the Tr cycle in which ACTV command output is performed, a WRIT command is issued in the Tc1, Tc2, and Tc3 cycles, and a WRITA command that performs auto-precharge is issued in the Tc4 cycle. In the write cycle, the write data is output at the same time as the write command. In case of the write with auto-precharge command, precharging of the relevant bank is performed in the synchronous DRAM after completion of the write command, and therefore no command can be issued for the same bank until precharging is completed. Consequently, in addition to the precharge wait cycle, Tpc, used in a read access, cycle Trwl is also added as a wait interval until precharging is started following the write command. Issuance of a new command for the same bank is deferred during this interval. The number of Trwl cycles can be specified by the TRWL bits in MCR.

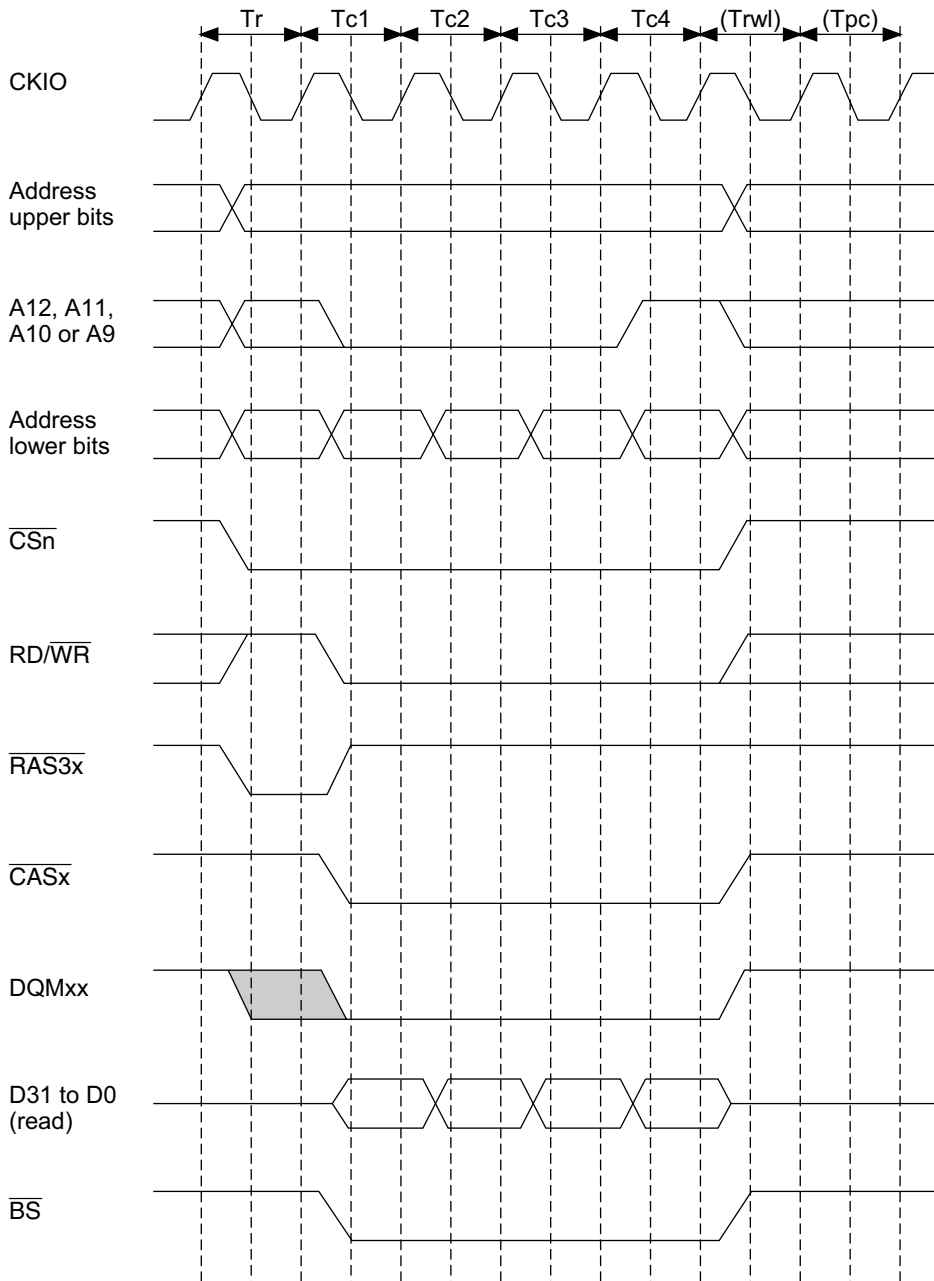

Figure 10.17 Basic Timing for Synchronous DRAM Burst Write

Single Write: The basic timing chart for write access is shown in figure 10.18. In a single write operation, following the T_r cycle in which ACTV command output is performed, a WRITA command that performs auto-precharge is issued in the T_{c1} cycle. In the write cycle, the write data is output at the same time as the write command. In case of the write with auto-precharge command, precharging of the relevant bank is performed in the synchronous DRAM after completion of the write command, and therefore no command can be issued for the same bank until precharging is completed. Consequently, in addition to the precharge wait cycle, T_{pc} , used in a read access, cycle T_{rwl} is also added as a wait interval until precharging is started following the write command. Issuance of a new command for the same bank is deferred during this interval. The number of T_{rwl} cycles can be specified by the TRWL bits in MCR.

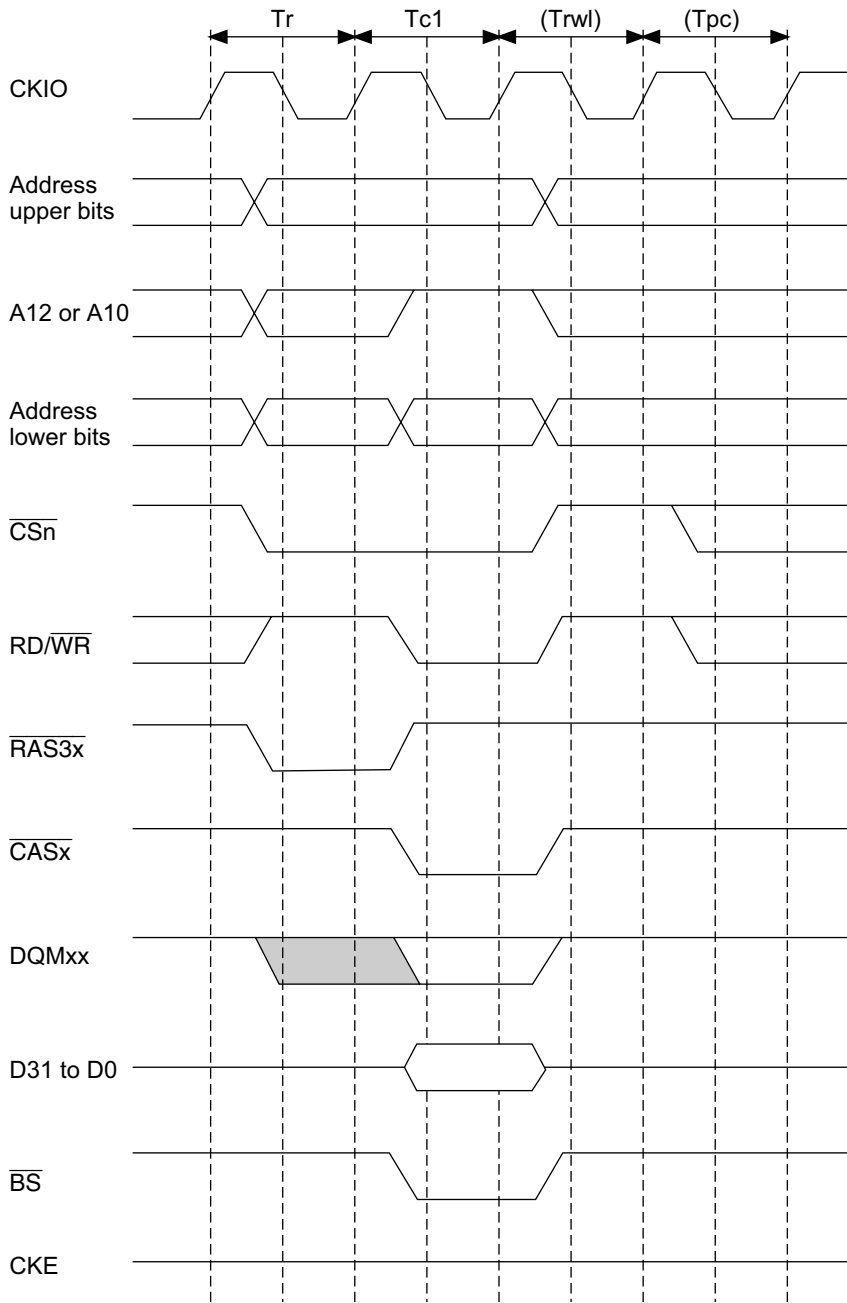

Figure 10.18 Basic Timing for Synchronous DRAM Single Write

Bank Active: The synchronous DRAM bank function is used to support high-speed accesses to the same row address. When the RASD bit in MCR is 1, read/write command accesses are performed using commands without auto-precharge (READ, WRIT). In this case, precharging is not performed when the access ends. When accessing the same row address in the same bank, it is possible to issue the READ or WRIT command immediately, without issuing an ACTV command, in the same way as in the RAS down state in DRAM fast page mode. As synchronous DRAM is internally divided into two or four banks, it is possible to activate one row address in each bank. If the next access is to a different row address, a PRE command is first issued to precharge the relevant bank, then when precharging is completed, the access is performed by issuing an ACTV command followed by a READ or WRIT command. If this is followed by an access to a different row address, the access time will be longer because of the precharging performed after the access request is issued.

In a write, when auto-precharge is performed, a command cannot be issued for a period of $Trwl + Tpc$ cycles after issuance of the WRITA command. When bank active mode is used, READ or WRIT commands can be issued successively if the row address is the same. The number of cycles can thus be reduced by $Trwl + Tpc$ cycles for each write. The number of cycles between issuance of the precharge command and the row address strobe command is determined by the TPC bits in MCR.

Whether faster execution speed is achieved by use of bank active mode or by use of basic access is determined by the probability of accessing the same row address ($P1$), and the average number of cycles from completion of one access to the next access (Ta). If Ta is greater than Tpc , the delay due to the precharge wait when writing is imperceptible. In this case, the access speed for bank active mode and basic access is determined by the number of cycles from the start of access to issuance of the read/write command: $(Tpc + Trcd) \times (1 - P1)$ and $Trcd$, respectively.

There is a limit on $Tras$, the time for placing each bank in the active state. If there is no guarantee that there will not be a cache hit and another row address will be accessed within the period in which this value is maintained by program execution, it is necessary to set auto-refresh and set the refresh cycle to no more than the maximum value of $Tras$. In this way, it is possible to observe the restrictions on the maximum active state time for each bank. If auto-refresh is not used, measures must be taken in the program to ensure that the banks do not remain active for longer than the prescribed time.

A burst read cycle without auto-precharge is shown in figure 10.19, a burst read cycle for the same row address in figure 10.20, and a burst read cycle for different row addresses in figure 10.21. Similarly, a burst write cycle without auto-precharge is shown in figure 10.22, a burst write cycle for the same row address in figure 10.23, and a burst write cycle for different row addresses in figure 10.24.

A Tnop cycle, in which no operation is performed, is inserted before the Tc cycle in which the READ command is issued in figure 10.20, but when synchronous DRAM is read, there is a two-cycle latency for the DQMxx signal that performs the byte specification. If the Tc cycle were performed immediately, without inserting a Tnop cycle, it would not be possible to perform the DQMxx signal specification for Td1 cycle data output. This is the reason for inserting the Tnop cycle. If the CAS latency is two cycles or longer, Tnop cycle insertion is not performed, since the timing requirements will be met even if the DQMxx signal is set after the Tc cycle.

When bank active mode is set, if only accesses to the respective banks in the area 3 space are considered, as long as accesses to the same row address continue, the operation starts with the cycle in figure 10.19 or 10.22, followed by repetition of the cycle in figure 10.20 or 10.23. An access to a different area 3 space during this time has no effect. If there is an access to a different row address in the bank active state, after this is detected the bus cycle in figure 10.21 or 10.24 is executed instead of that in figure 10.20 or 10.23. In bank active mode, too, all banks become inactive after a refresh cycle or after the bus is released as the result of bus arbitration.

The bank active mode should not be used unless the bus width for all areas is 32 bits.

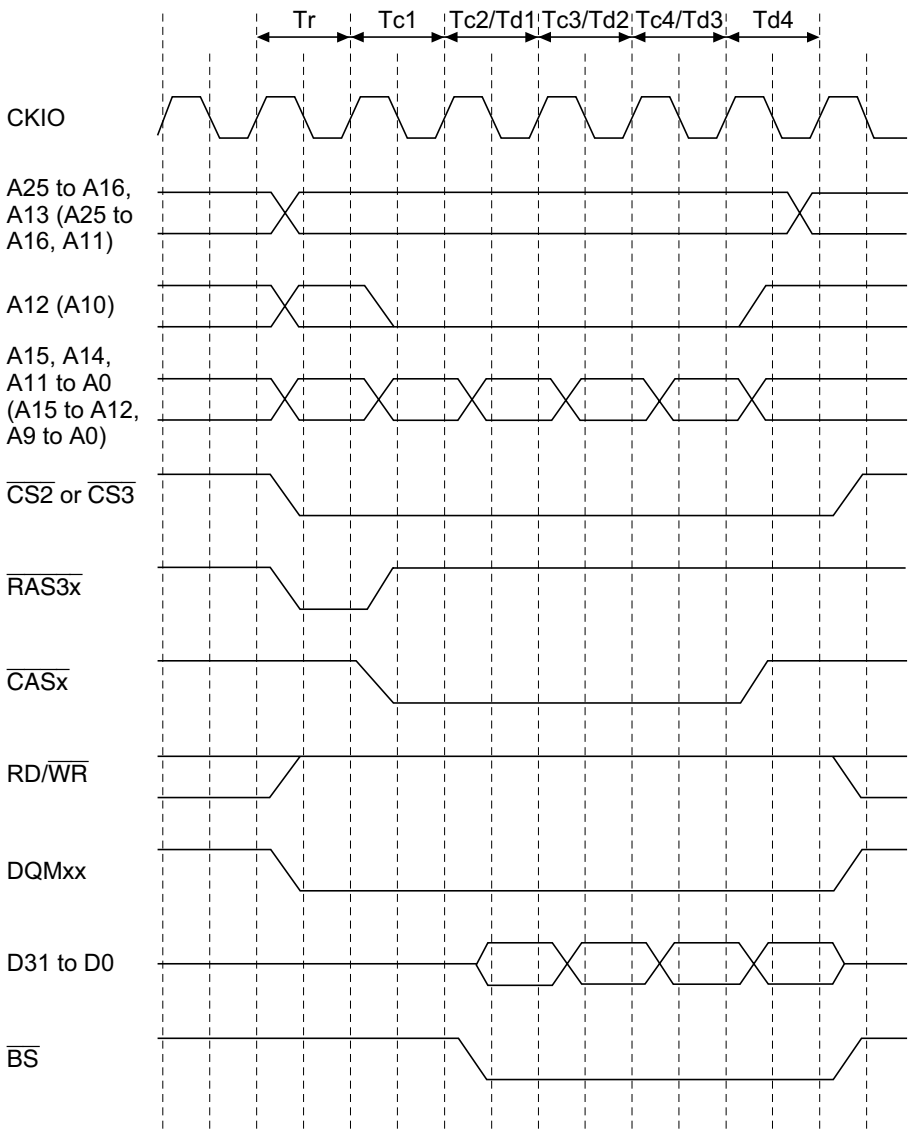

Figure 10.19 Burst Read Timing (No Precharge)

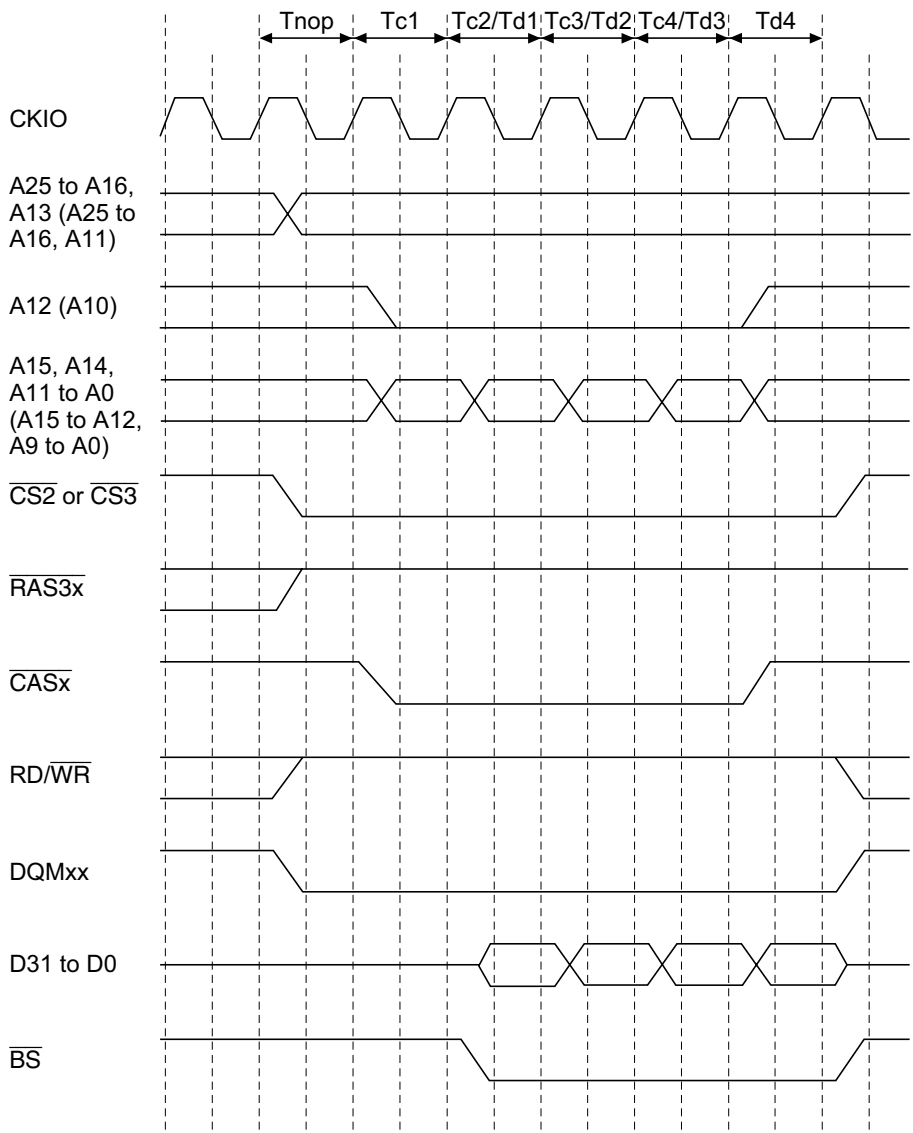

Figure 10.20 Burst Read Timing (Same Row Address)

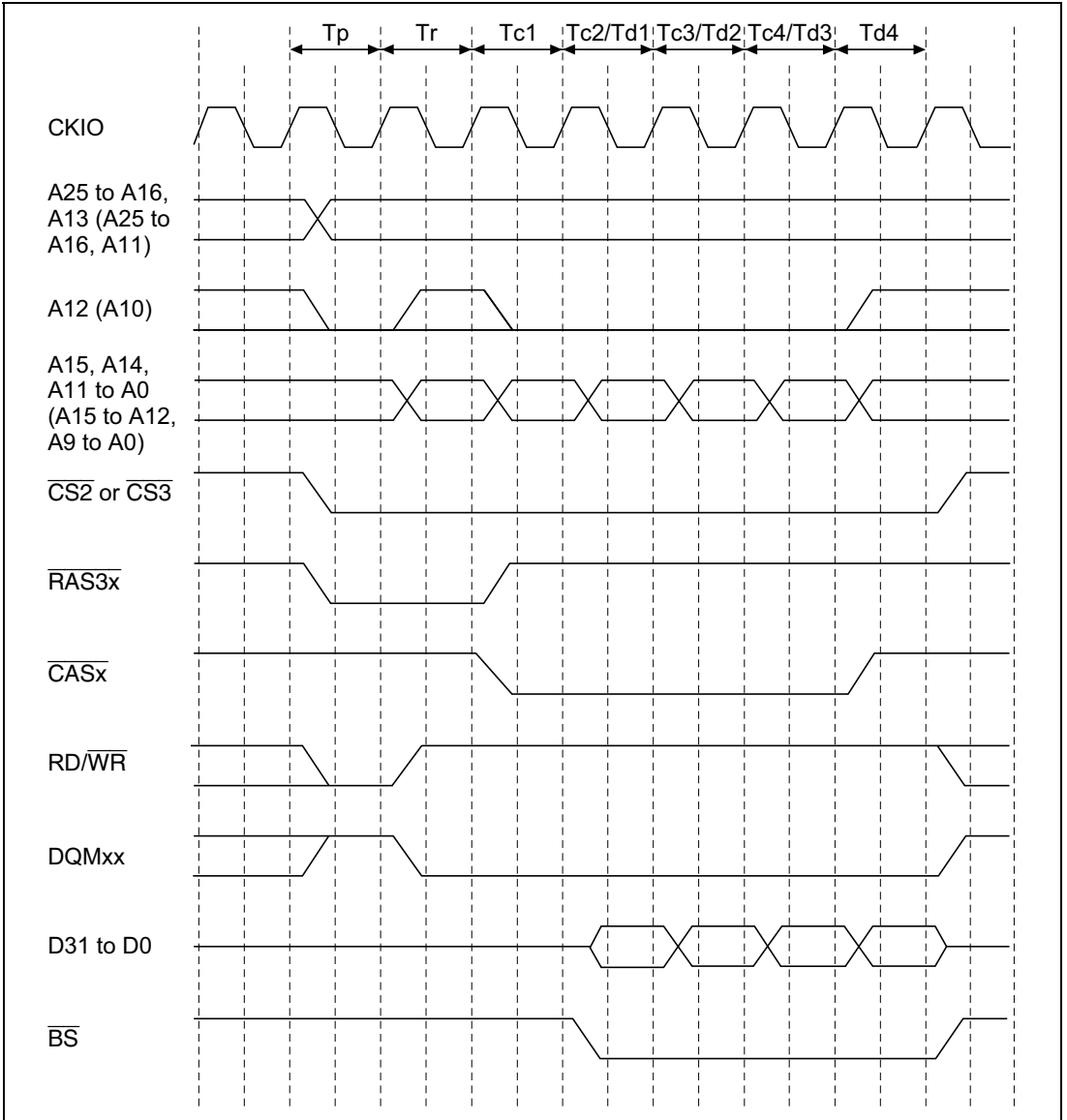

Figure 10.21 Burst Read Timing (Different Row Addresses)

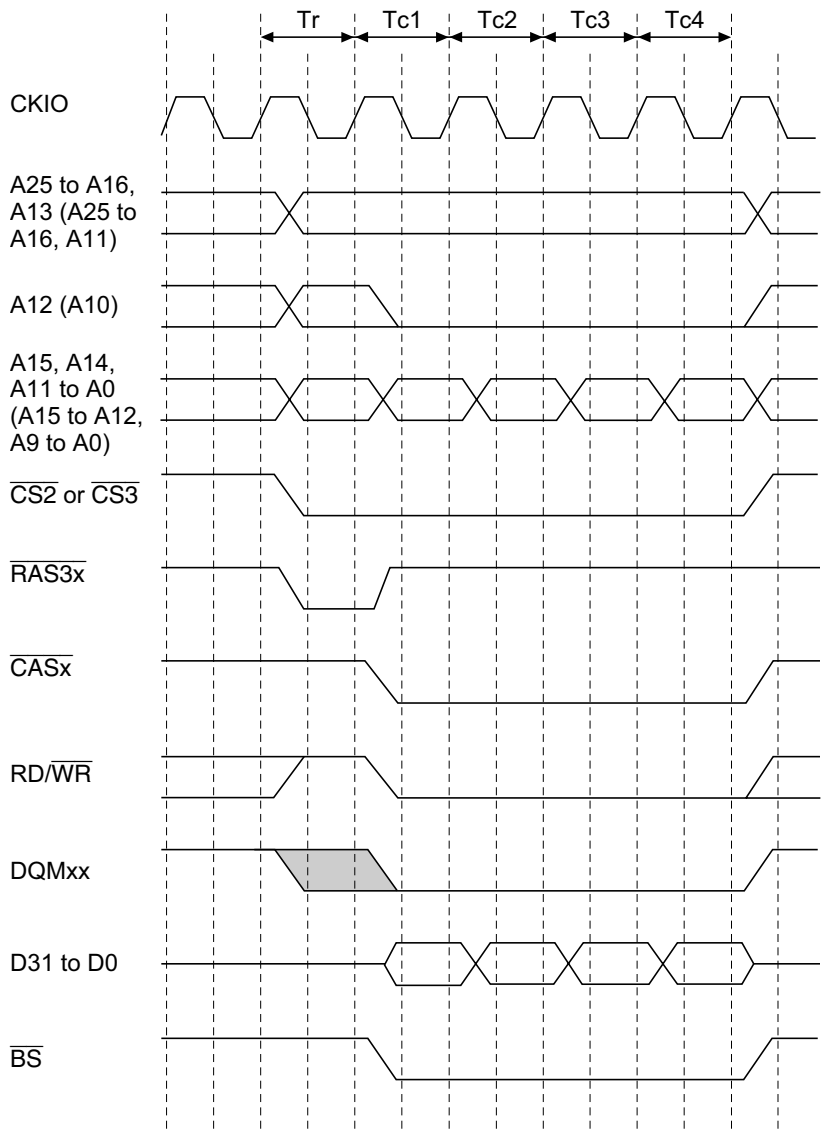

Figure 10.22 Burst Write Timing (No Precharge)

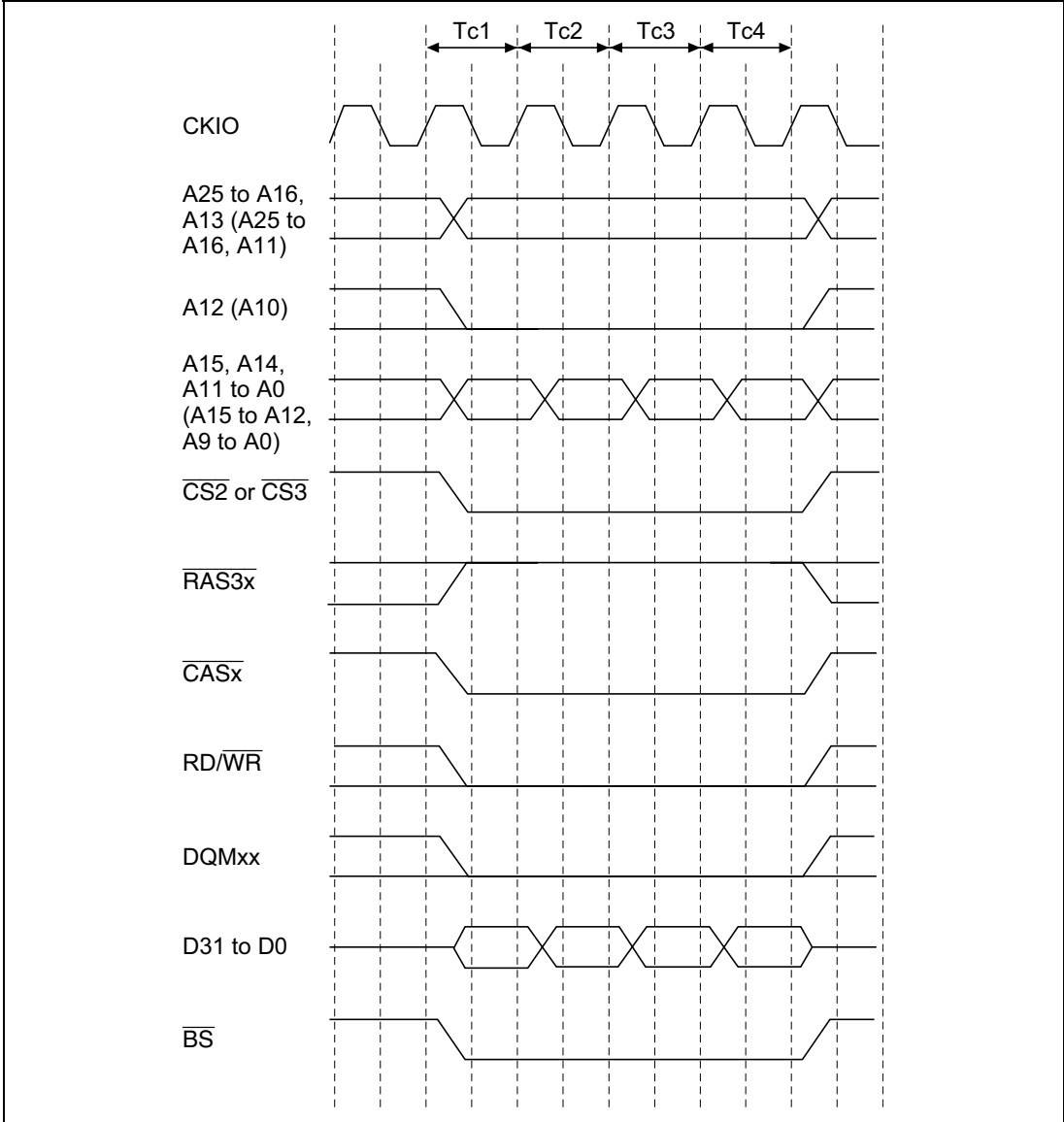

Figure 10.23 Burst Write Timing (Same Row Address)

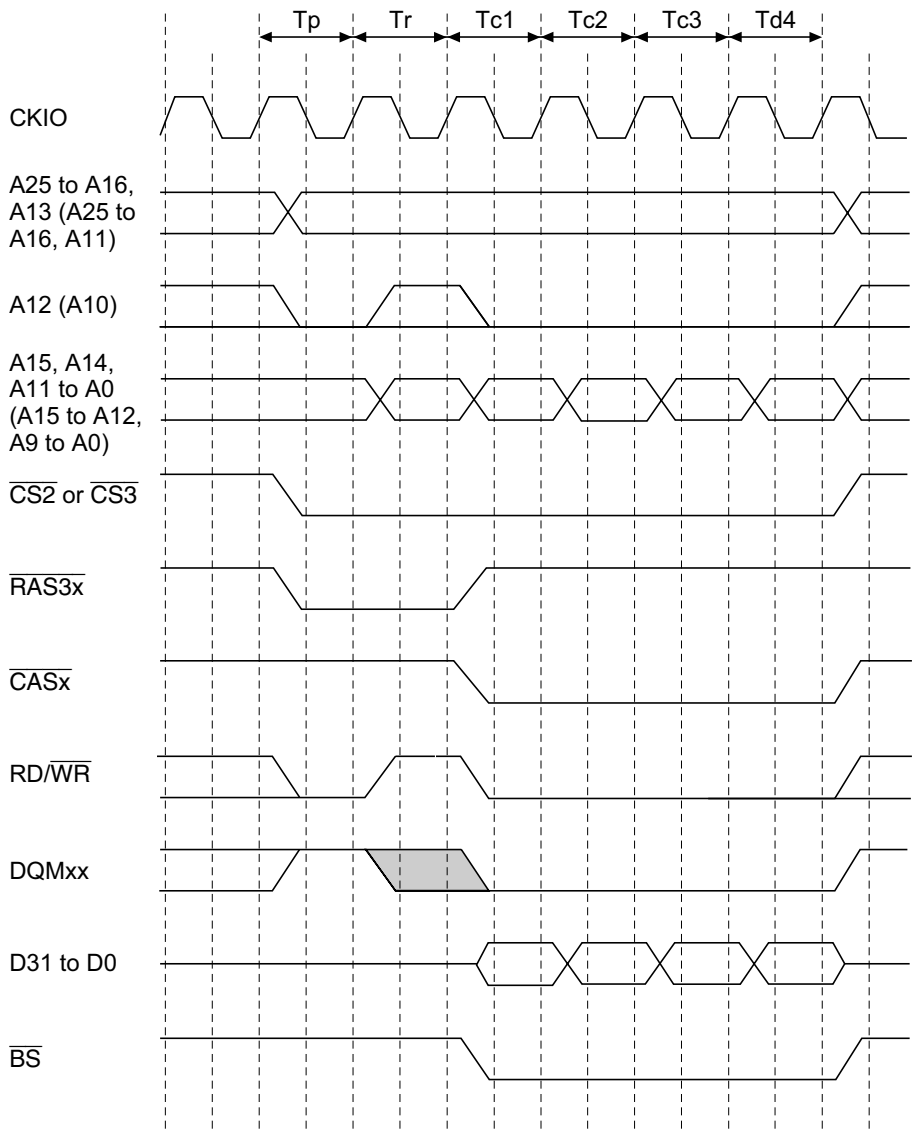

Figure 10.24 Burst Write Timing (Different Row Addresses)

Refreshing: The bus state controller is provided with a function for controlling synchronous DRAM refreshing. Auto-refreshing can be performed by clearing the RMODE bit to 0 and setting the RFSH bit to 1 in MCR. If synchronous DRAM is not accessed for a long period, self-refresh mode, in which the power consumption for data retention is low, can be activated by setting both the RMODE bit and the RFSH bit to 1.

- Auto-Refreshing

Refreshing is performed at intervals determined by the input clock selected by bits CKS2-0 in RTCSR, and the value set in RTCOR. The value of bits CKS2-0 in RTCOR should be set so as to satisfy the refresh interval stipulation for the synchronous DRAM used. First make the settings for RTCOR, RTCNT, and the RMODE and RFSH bits in MCR, then make the CKS2-CKS0 setting. When the clock is selected by CKS2-CKS0, RTCNT starts counting up from the value at that time. The RTCNT value is constantly compared with the RTCOR value, and if the two values are the same, a refresh request is generated and an auto-refresh is performed. At the same time, RTCNT is cleared to zero and the count-up is restarted. Figure 10.25 shows the auto-refresh cycle timing.

All-bank precharging is performed in the T_p cycle, then an REF command is issued in the TR_r cycle following the interval specified by the TPC bits in MCR. After the TR_r cycle, new command output cannot be performed for the duration of the number of cycles specified by the TRAS bits in MCR plus the number of cycles specified by the TPC bits in MCR. The TRAS and TPC bits must be set so as to satisfy the synchronous DRAM refresh cycle time stipulation (active/active command delay time).

Auto-refreshing is performed in normal operation, in sleep mode, and in case of a manual reset.

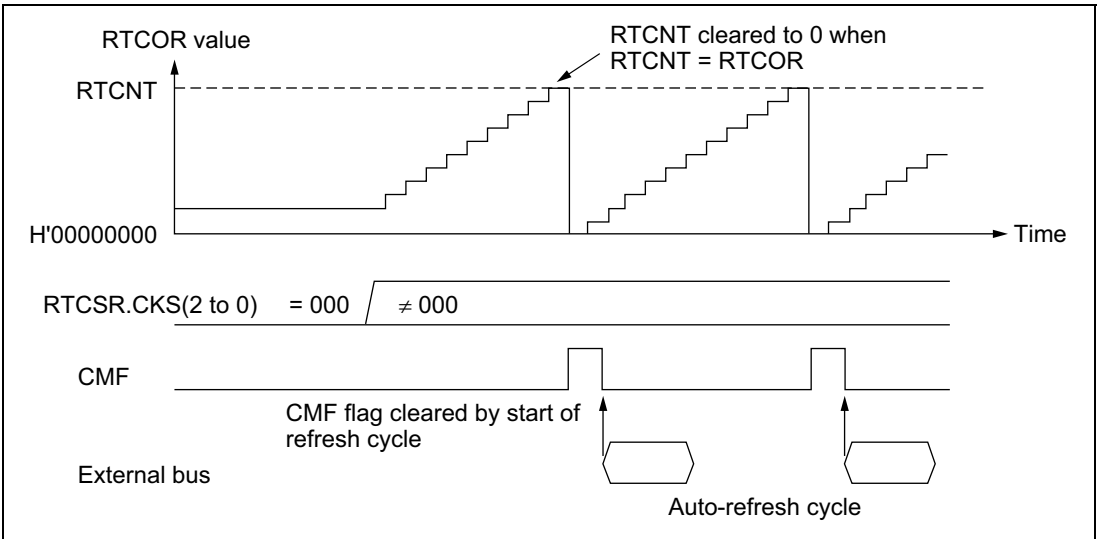

Figure 10.25 Auto-Refresh Operation

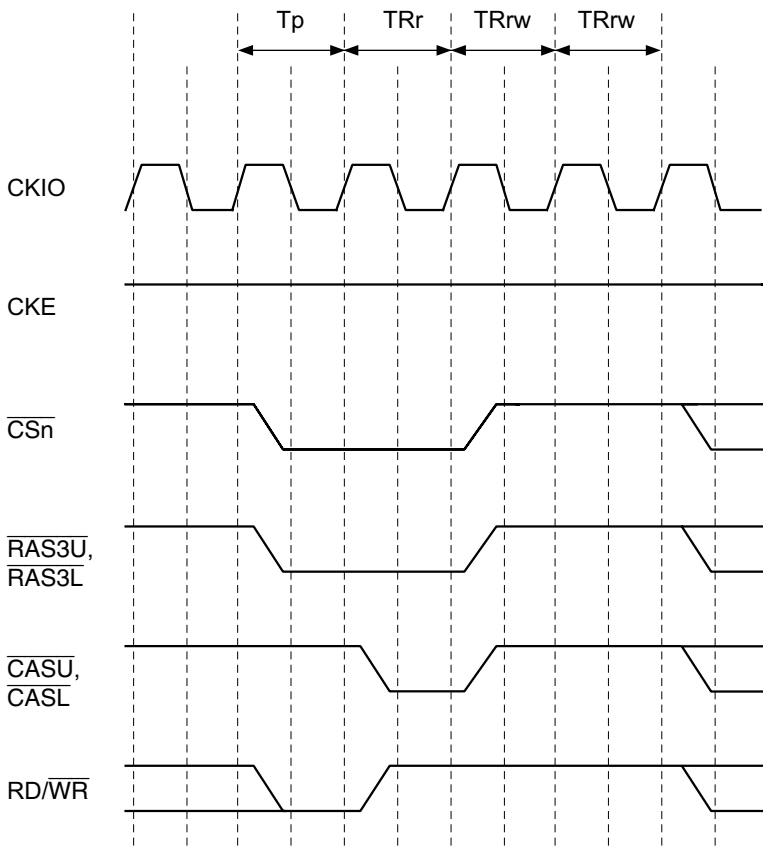

Figure 10.26 Synchronous DRAM Auto-Refresh Timing

- Self-Refreshing

Self-refresh mode is a kind of standby mode in which the refresh timing and refresh addresses are generated within the synchronous DRAM. Self-refreshing is activated by setting both the RMODE bit and the RFSH bit to 1. The self-refresh state is maintained while the CKE signal is low. Synchronous DRAM cannot be accessed while in the self-refresh state. Self-refresh mode is cleared by clearing the RMODE bit to 0. After self-refresh mode has been cleared, command issuance is disabled for the number of cycles specified by the TPC bits in MCR. Self-refresh timing is shown in figure 10.27. Settings must be made so that self-refresh clearing and data retention are performed correctly, and auto-refreshing is performed at the correct intervals. When self-refreshing is activated from the state in which auto-refreshing is set, or when exiting standby mode other than through a power-on reset, auto-refreshing is restarted if RFSH is set to 1 and RMODE is cleared to 0 when self-refresh mode is cleared. If the transition from clearing of self-refresh mode to the start of auto-refreshing takes time, this time should be taken into consideration when setting the initial value of RTCNT. Making the RTCNT value 1 less than the RTCOR value will enable refreshing to be started immediately.

After self-refreshing has been set, the self-refresh state continues even if the chip standby state is entered using the SH7709S's standby function, and is maintained even after recovery from standby mode other than through a power-on reset. In case of a power-on reset, the bus state controller's registers are initialized, and therefore the self-refresh state is cleared.

Self-refreshing is performed in normal operation, in sleep mode, in standby mode, and in case of a manual reset.

When using synchronous DRAM, use the following procedure to initiate self-refreshing.

1. Clear the refresh control bit to 0.
2. Write H'00 to the RTCNT register.
3. Set the refresh control bit and refresh mode bit to 1.

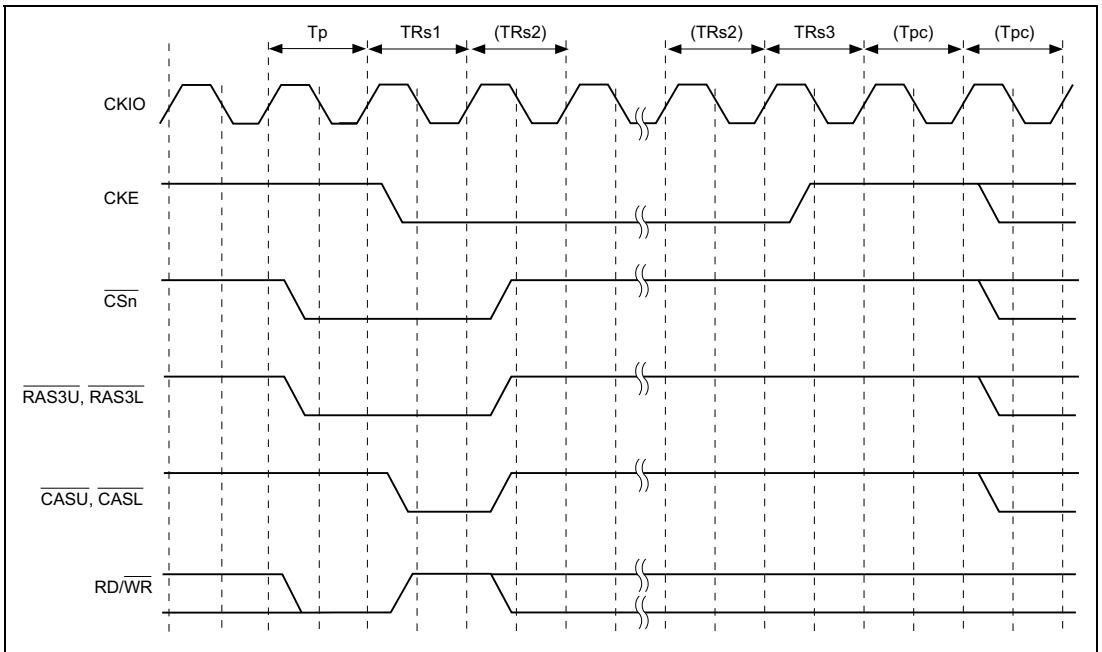

Figure 10.27 Synchronous DRAM Self-Refresh Timing

- Relationship between Refresh Requests and Bus Cycle Requests

If a refresh request is generated during execution of a bus cycle, execution of the refresh is deferred until the bus cycle is completed. If a refresh request occurs when the bus has been released by the bus arbiter, refresh execution is deferred until the bus is acquired. If a match between RTCNT and RTCOR occurs while a refresh is waiting to be executed, so that a new refresh request is generated, the previous refresh request is eliminated. In order for refreshing to be performed normally, care must be taken to ensure that no bus cycle or bus right occurs that is longer than the refresh interval. When a refresh request is generated, the $\overline{\text{IRQOUT}}$ pin is asserted (driven low). Therefore, normal refreshing can be performed by having the $\overline{\text{IRQOUT}}$ pin monitored by a bus master other than the SH7709S requesting the bus, or the bus arbiter, and returning the bus to the SH7709S. When refreshing is started, and if no other interrupt request has been generated, the $\overline{\text{IRQOUT}}$ pin is negated (driven high).

Power-On Sequence: In order to use synchronous DRAM, mode setting must first be performed after powering on. To perform synchronous DRAM initialization correctly, the bus state controller registers must first be set, followed by a write to the synchronous DRAM mode register. In synchronous DRAM mode register setting, the address signal value at that time is latched by a combination of the $\overline{\text{RAS}}$, $\overline{\text{CAS}}$, and $\text{RD}/\overline{\text{WR}}$ signals. If the value to be set is X, the bus state controller provides for value X to be written to the synchronous DRAM mode register by performing a write to address $\text{H'FFFFD000} + \text{X}$ for area 2 synchronous DRAM, and to address $\text{H'FFFFE000} + \text{X}$ for area 3 synchronous DRAM. In this operation the data is ignored, but the mode write is performed as a byte-size access. To set burst read/single write, CAS latency 1 to 3, wrap type = sequential, and burst length 1 supported by the SH7709S, arbitrary data is written in a byte-size access to the following addresses.

With 32-bit bus width:

	Area 2	Area 3
CAS latency 1	FFFFD840	FFFFE840
CAS latency 2	FFFFD880	FFFFE880
CAS latency 3	FFFFD8C0	FFFFE8C0

With 16-bit bus width:

	Area 2	Area 3
CAS latency 1	FFFFD420	FFFFE420
CAS latency 2	FFFFD440	FFFFE440
CAS latency 3	FFFFD460	FFFFE460

Mode register setting timing is shown in figure 10.28.

As a result of the write to address $\text{H'FFFFD000} + \text{X}$ or $\text{H'FFFFE000} + \text{X}$, a precharge all banks (PALL) command is first issued in the TRp1 cycle, then a mode register write command is issued in the TMw1 cycle.

Address signals, when the mode-register write command is issued, are as follows:

32-bit bus width:

A15–A9 = 0000100 (burst read and single write)

A8–A6 = CAS latency

A5 = 0 (burst type = sequential)

A4–A2 = 000 (burst length 1)

16-bit bus width:

A14–A8 = 0000100 (burst read and single write)

A7–A5 = CAS latency

A4 = 0 (burst type = sequential)

A3–A1 = 000 (burst length 1)

Before mode register setting, a 100 μ s idle time (depending on the memory manufacturer) must be guaranteed after powering on requested by the synchronous DRAM. If the reset signal pulse width is greater than this idle time, there is no problem in performing mode register setting immediately. The number of dummy auto-refresh cycles specified by the manufacturer (usually 8) or more must be executed. This is usually achieved automatically while various kinds of initialization are being performed after auto-refresh setting, but a way of carrying this out more dependably is to set a short refresh request generation interval just while these dummy cycles are being executed. With simple read or write access, the address counter in the synchronous DRAM used for auto-refreshing is not initialized, and so the cycle must always be an auto-refresh cycle.

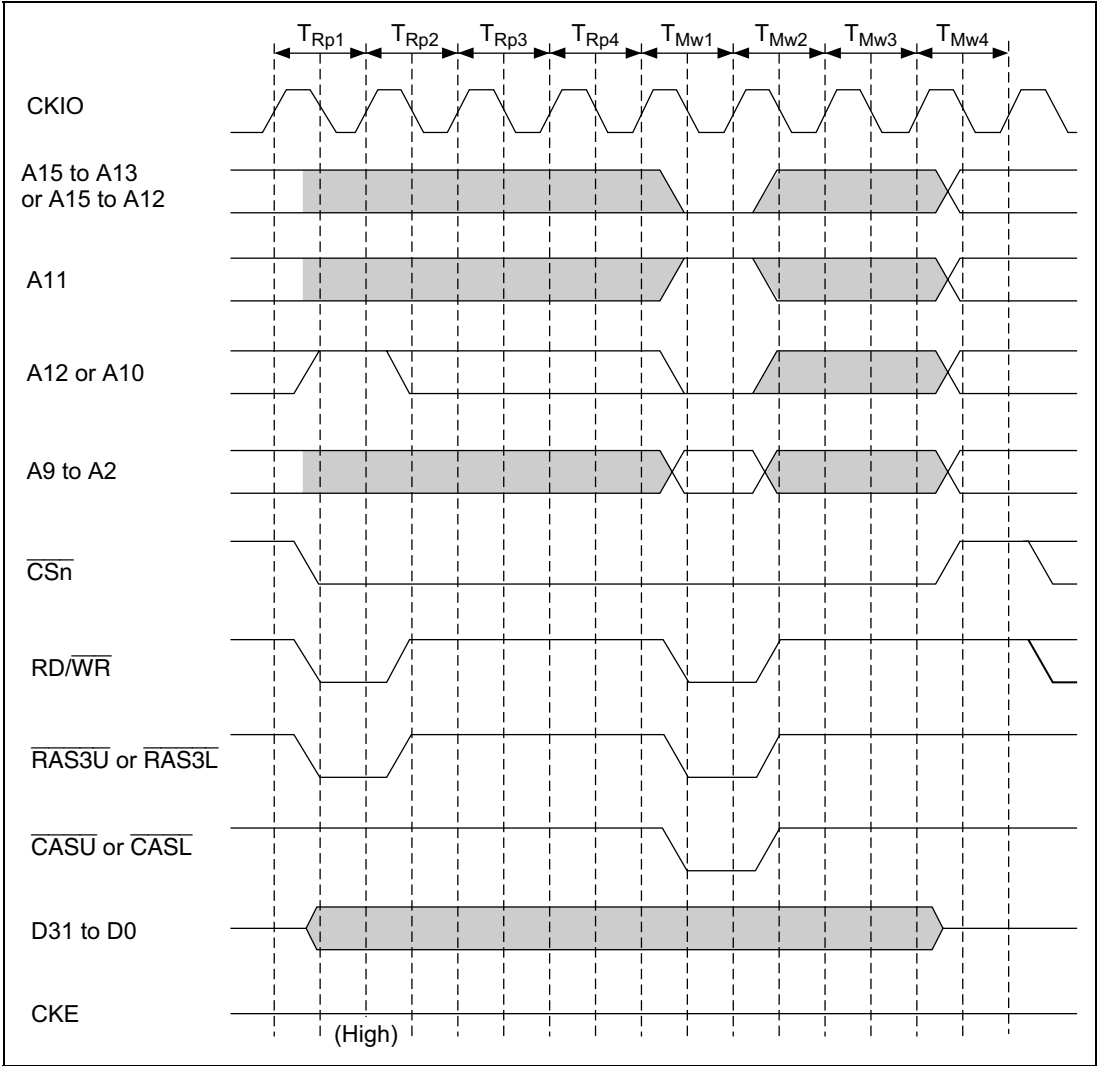

Figure 10.28 Synchronous DRAM Mode Write Timing

10.3.5 Burst ROM Interface

Setting bits A0BST1–0, A5BST1–0, and A6BST1–0 in BCR1 to a non-zero value allows burst ROM to be connected to areas 0, 5, and 6. The burst ROM interface provides high-speed access to ROM that has a nibble access function. The timing for nibble access to burst ROM is shown in figure 10.29. Two wait cycles are set. Basically, access is performed in the same way as for normal space, but when the first cycle ends the $\overline{CS0}$ signal is not negated, and only the address is changed before the next access is executed. When 8-bit ROM is connected, the number of consecutive accesses can be set as 4, 8, or 16 by bits A0BST1–0, A5BST1–0, or A6BST1–0. When 16-bit ROM is connected, 4 or 8 can be set in the same way. When 32-bit ROM is connected, only 4 can be set.

\overline{WAIT} pin sampling is performed in the first access if one or more wait states are set, and is always performed in the second and subsequent accesses.

The second and subsequent access cycles also comprise two cycles when a burst ROM setting is made and the wait specification is 0. The timing in this case is shown in figure 10.30.

However, the \overline{WAIT} signal is ignored in the following three cases:

- A write to external address space in dual address mode with 16-byte DMA transfer
- Transfer from an external device with DACK to external address space in single address mode with 16-byte DMA transfer
- Cache write-back access

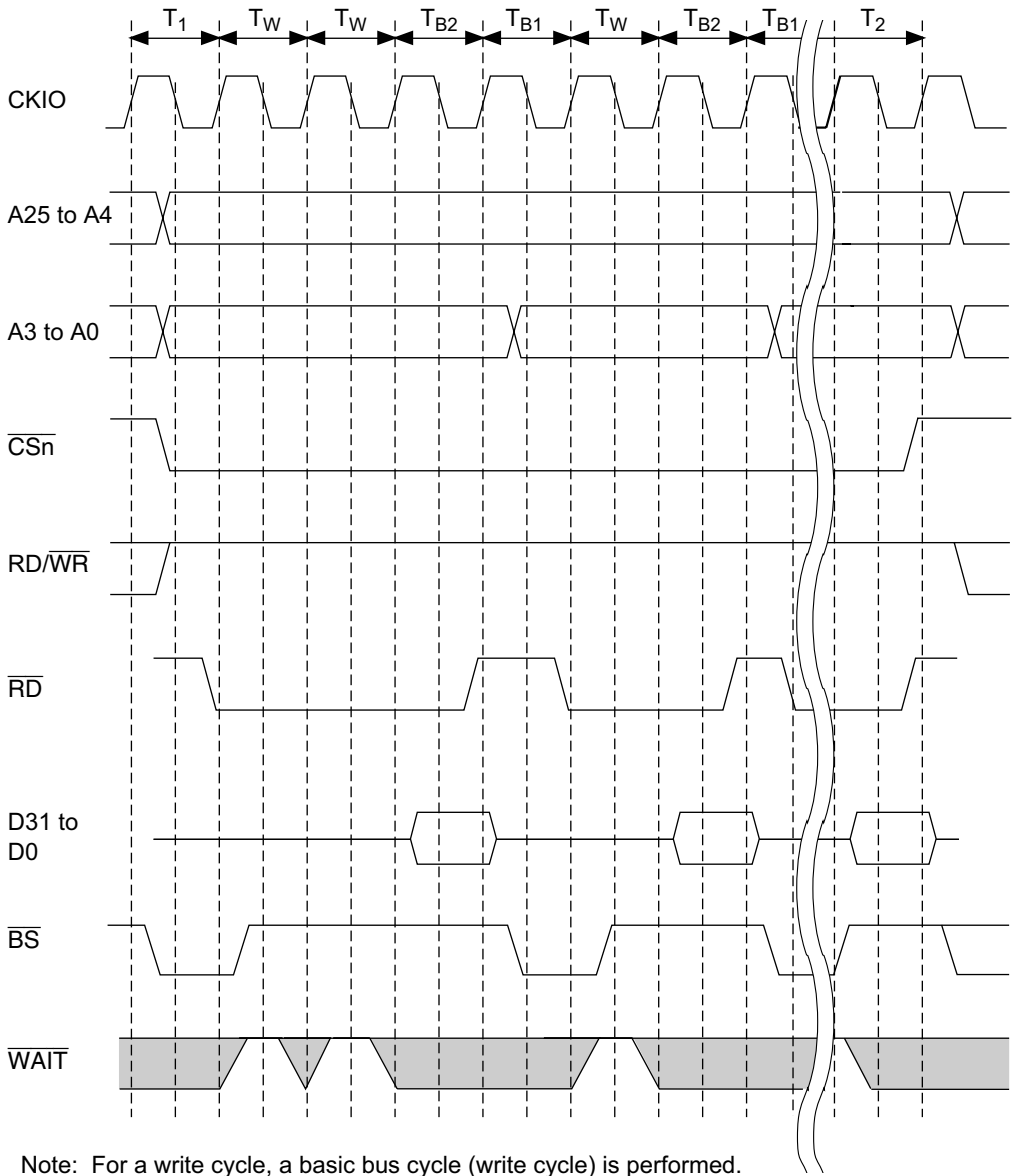
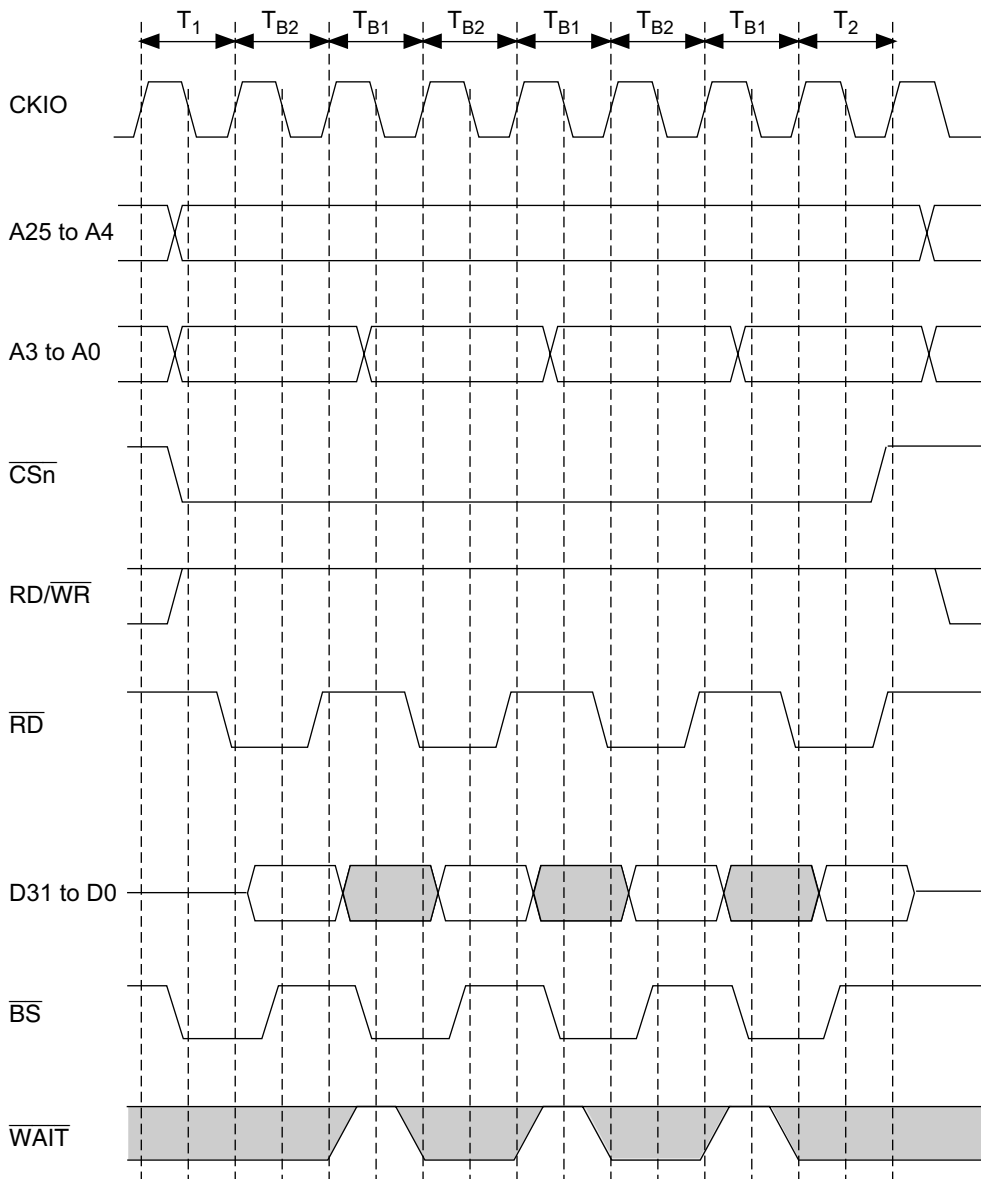

Figure 10.29 Burst ROM Wait Access Timing



Note: For a write cycle, a basic bus cycle (write cycle) is performed.

Figure 10.30 Burst ROM Basic Access Timing

10.3.6 PCMCIA Interface

In the SH7709S, setting the A5PCM bit in BCR1 to 1 makes the bus interface for physical space area 5 an IC memory card and I/O card interface as stipulated in JEIDA version 4.2 (PCMCIA2.1). Setting the A6PCM bit to 1 makes the bus interface for physical space area 6 an IC memory card and I/O card interface as stipulated in JEIDA version 4.2.

When the PCMCIA interface is used, a bus size of 8 or 16 bits can be set by bits A5SZ1 and A5SZ0, or A6SZ1 and A6SZ0, in BCR2.

Figure 10.31 shows an example of PCMCIA card connection to the SH7709S. To enable active insertion of the PCMCIA cards (i.e. insertion or removal while system power is being supplied), a 3-state buffer must be connected between the SH7709S's bus interface and the PCMCIA cards.

As operation in big-endian mode is not explicitly stipulated in the JEIDA/PCMCIA specifications, the PCMCIA interface for the SH7709S in big-endian mode is stipulated independently.

However, the $\overline{\text{WAIT}}$ signal is ignored in the following three cases:

- A write to external address space in dual address mode with 16-byte DMA transfer
- Transfer from an external device with DACK to external address space in single address mode with 16-byte DMA transfer
- Cache write-back access

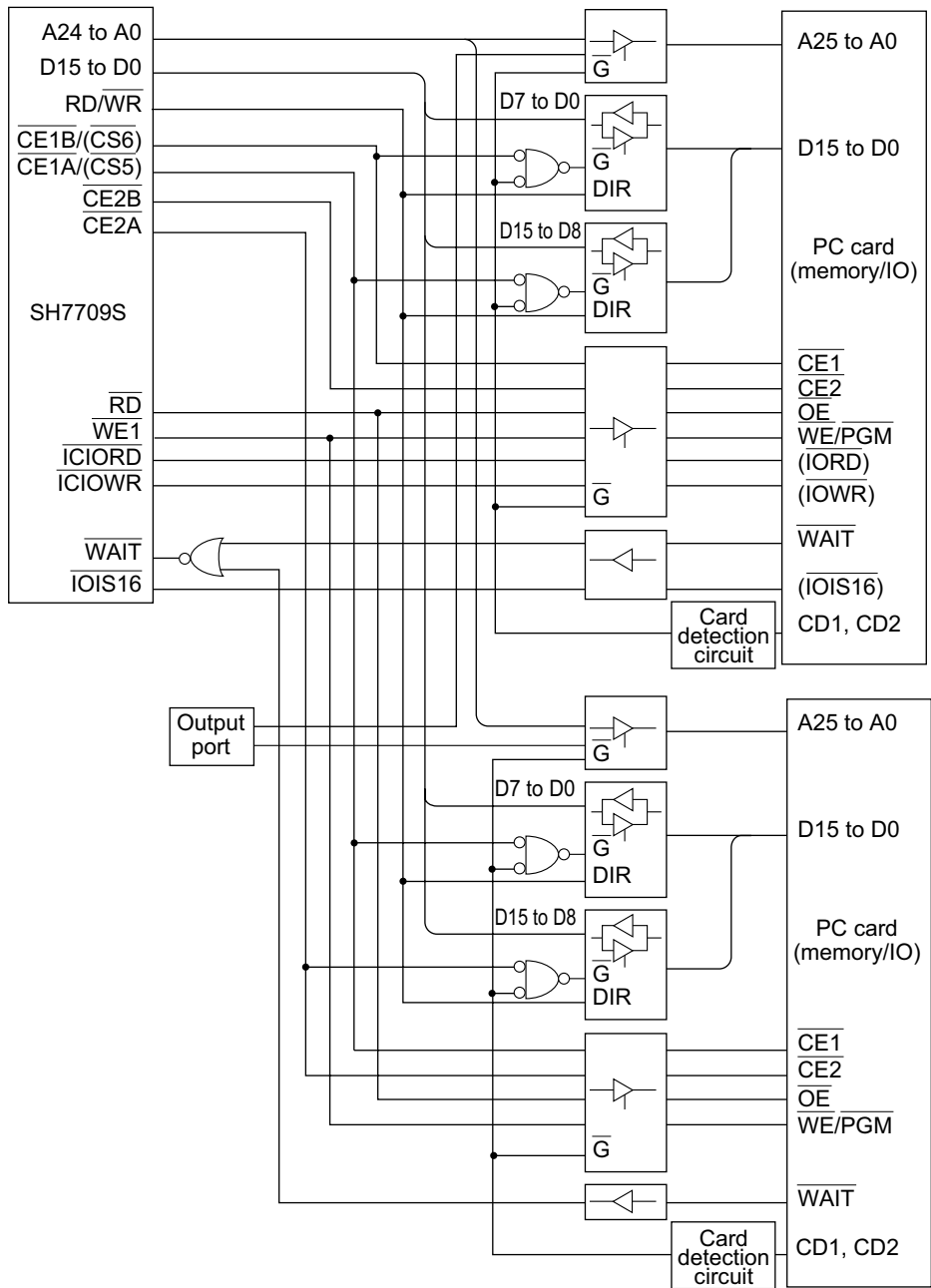

Figure 10.31 Example of PCMCIA Interface

Memory Card Interface Basic Timing: Figure 10.32 shows the basic timing for the PCMCIA IC memory card interface. When physical space areas 5 and 6 are designated as PCMCIA interface areas, bus accesses are automatically performed as IC memory card interface accesses.

With a high external bus frequency (\overline{CKIO}), the setup and hold times for the address (A_{24-A0}), card enable ($\overline{CS5}$, $\overline{CE2A}$, $\overline{CS6}$, $\overline{CE2B}$), and write data (D_{15-D0}) in a write cycle, become insufficient with respect to \overline{RD} and \overline{WR} (the \overline{WE} pin in the SH7709S). The SH7709S provides for this by enabling setup and hold times to be set for physical space areas 5 and 6 in the PCR register. Also, software waits by means of a WCR2 register setting and hardware waits by means of the \overline{WAIT} pin can be inserted in the same way as for the basic interface. Figure 10.33 shows the PCMCIA memory bus wait timing.

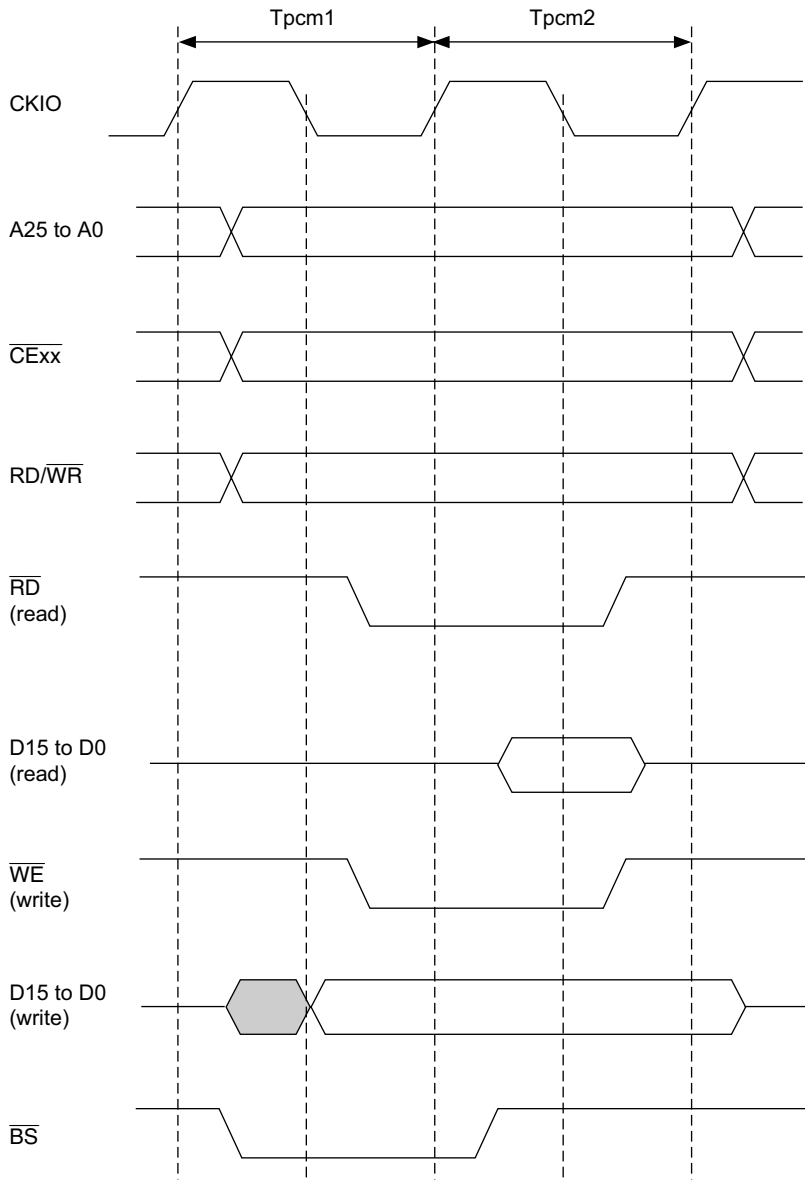

Figure 10.32 Basic Timing for PCMCIA Memory Card Interface

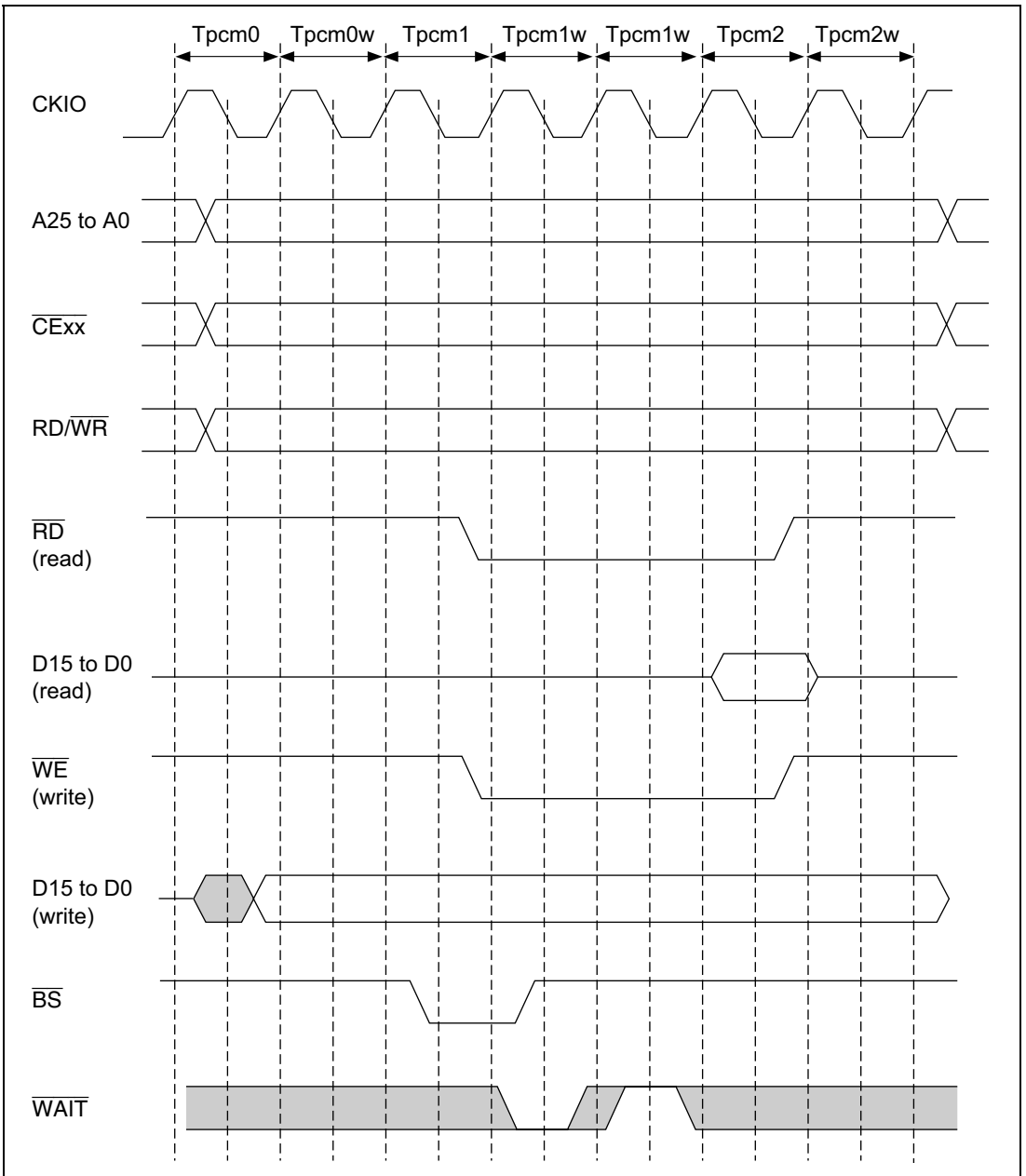

Figure 10.33 Wait Timing for PCMCIA Memory Card Interface

Memory Card Interface Burst Timing: In the SH7709S, when the IC memory card interface is selected, page mode burst access mode can be used, for read access only, by setting bits A5BST1 and A5BST0 in BCR1 for physical space area 5, or bits A6BST1 and A6BST0 in BCR1 for area 6. This burst access mode is not stipulated in JEIDA version 4.2 (PCMCIA2.1), but allows high-speed data access using ROM provided with a burst mode, etc.

Burst access mode timing is shown in figures 10.34 and 10.35.

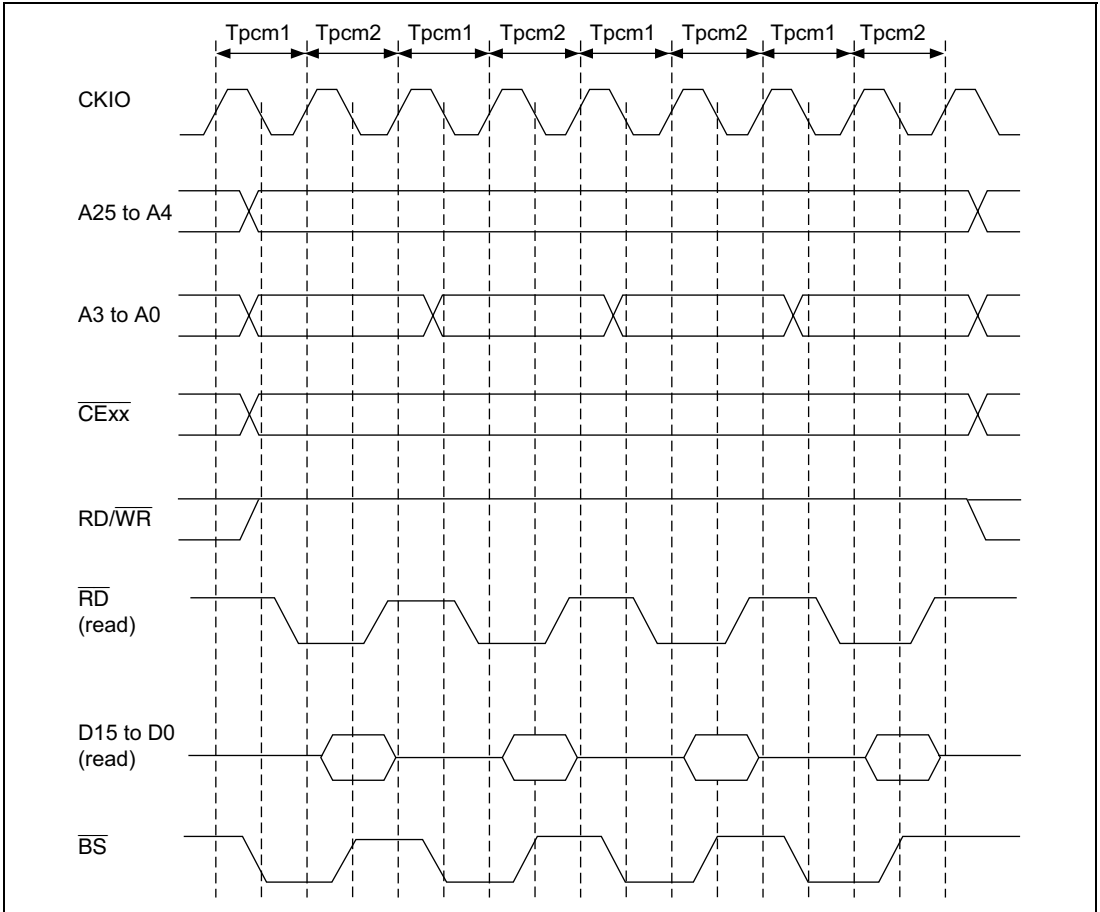

Figure 10.34 Basic Timing for PCMCIA Memory Card Interface Burst Access

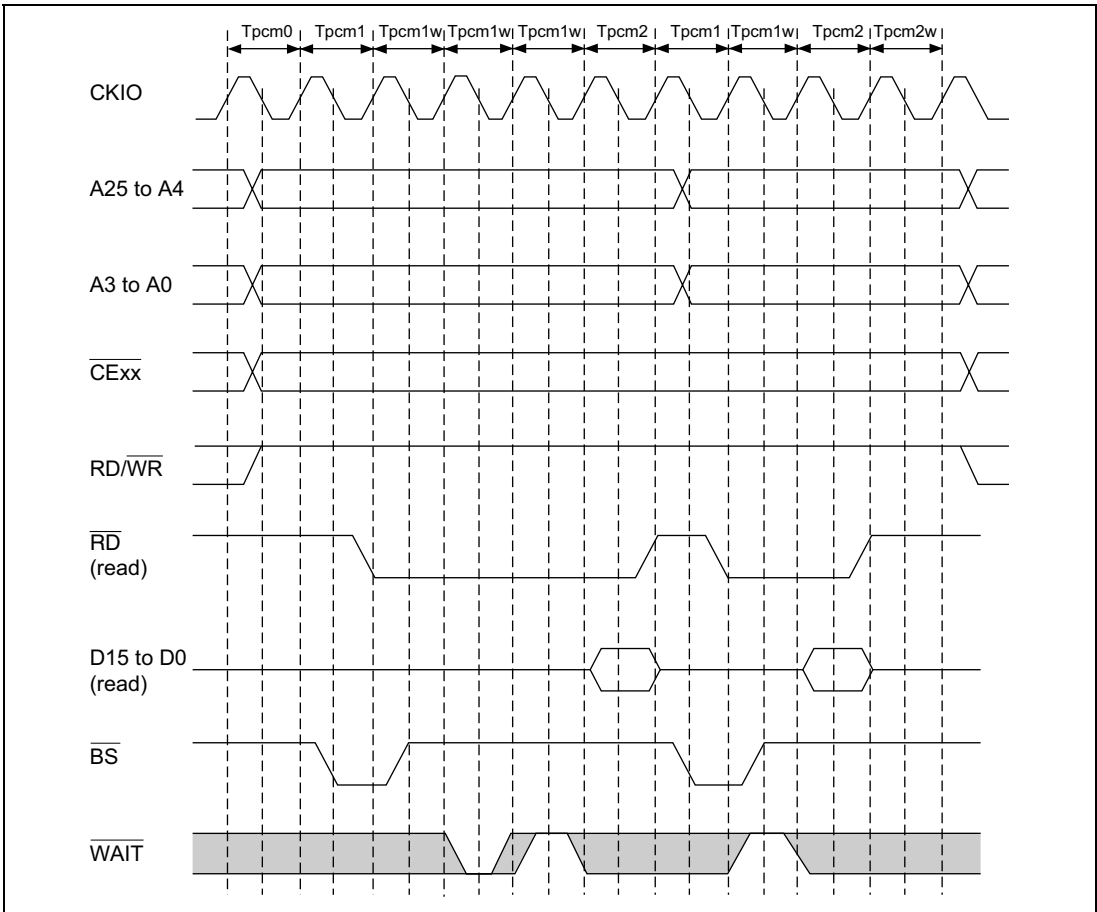

Figure 10.35 Wait Timing for PCMCIA Memory Card Interface Burst Access

I/O Card Interface Timing: Figures 10.37 and 10.38 show the timing for the PCMCIA I/O card interface.

Switching between the I/O card interface and the IC memory card interface is performed according to the accessed address. When PCMCIA is designed for physical space area 5, the bus access is automatically performed as an I/O card interface access when a physical address from H'16000000 to H'17FFFFFF is accessed. When PCMCIA is designated for physical space area 6, the bus access is automatically performed as an I/O card interface access when a physical address from H'1A000000 to H'1BFFFFFF is accessed.

When accessing a PCMCIA I/O card, the access should be performed using a non-cacheable area in virtual space (P2 or P3 space) or an area specified as non-cacheable by the MMU.

When an I/O card interface access is made to a PCMCIA card in little-endian mode, dynamic sizing of the I/O bus width is possible using the $\overline{\text{IOIS16}}$ pin. When a 16-bit bus width is set for area 5 or area 6, if the $\overline{\text{IOIS16}}$ signal is high during a word-size I/O bus cycle, the I/O port is recognized as being 8 bits in width. In this case, a data access for only 8 bits is performed in the I/O bus cycle being executed, followed automatically by a data access for the remaining 8 bits.

Figure 10.39 shows the basic timing for dynamic bus sizing.

In big-endian mode, the $\overline{\text{IOIS16}}$ signal is not supported, and should be fixed low.

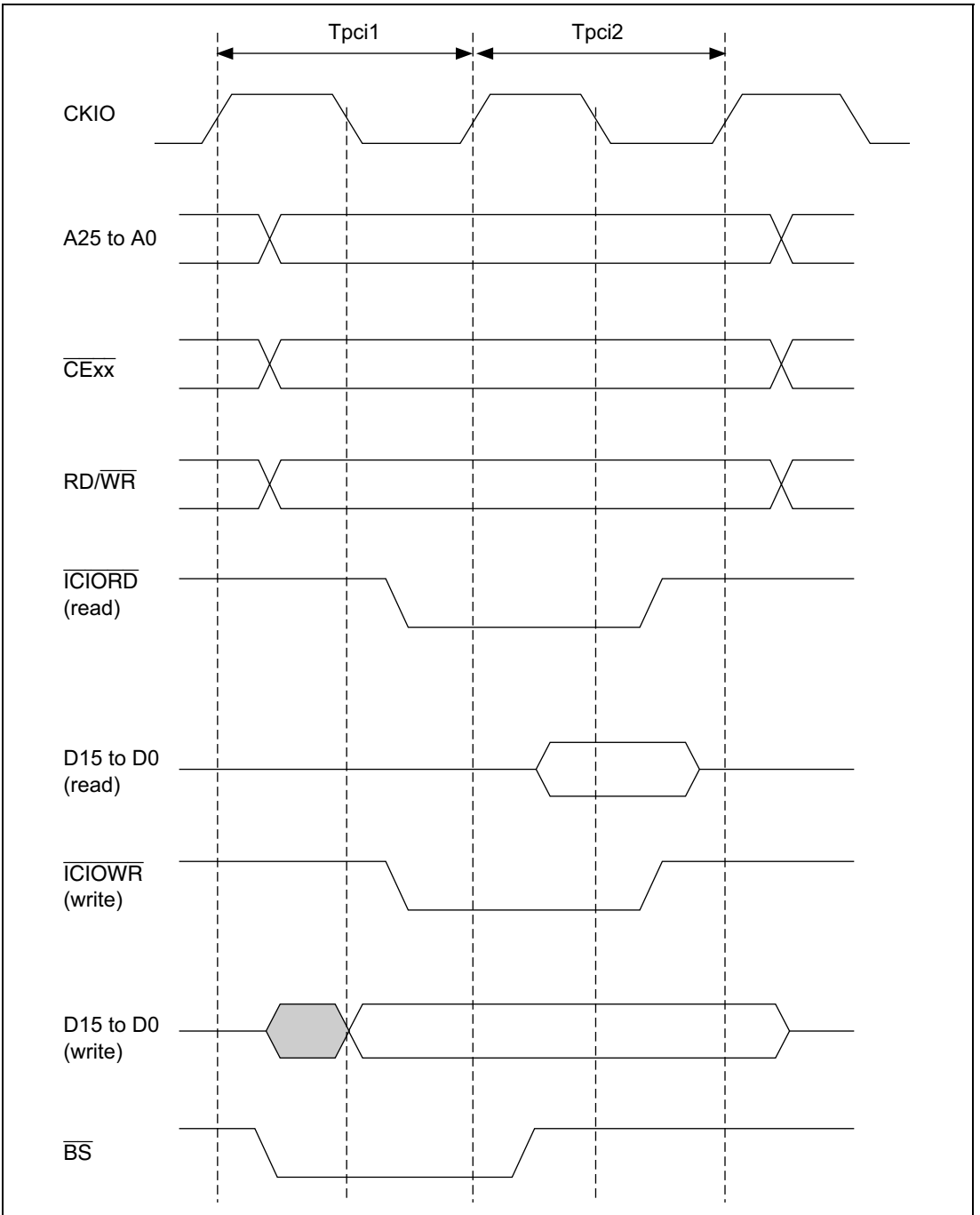

Figure 10.37 Basic Timing for PCMCIA I/O Card Interface

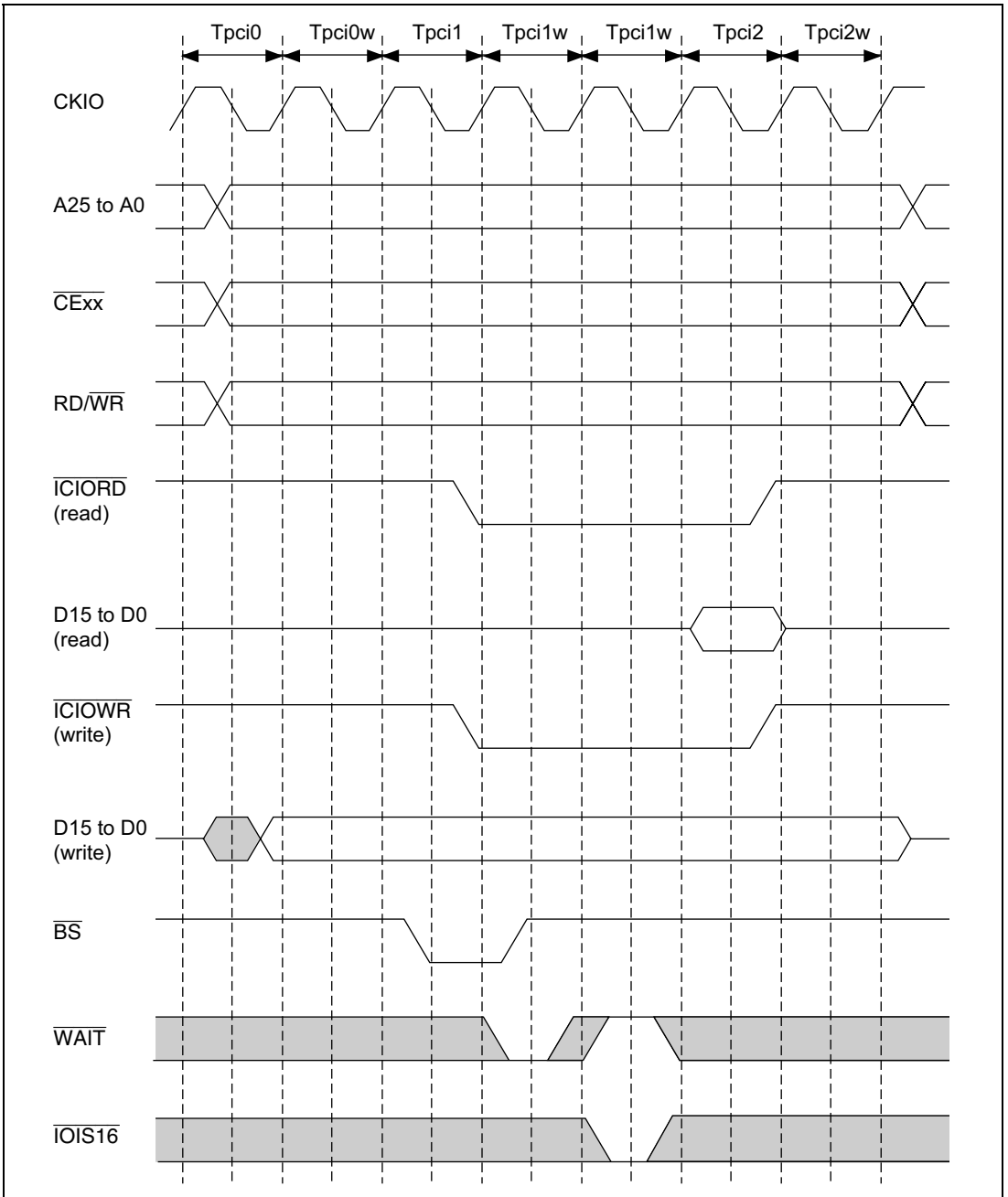

Figure 10.38 Wait Timing for PCMCIA I/O Card Interface

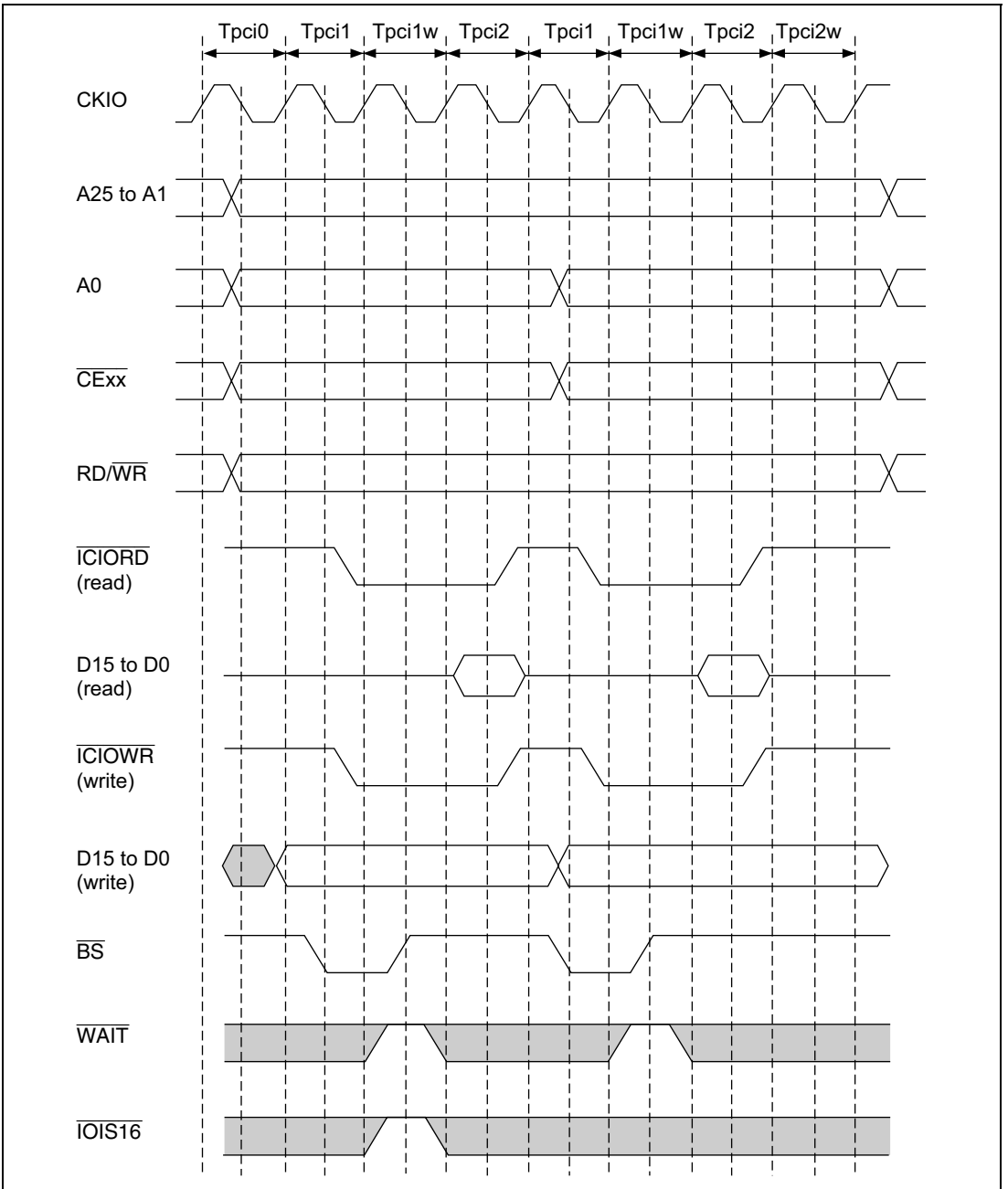

Figure 10.39 Dynamic Bus Sizing Timing for PCMCIA I/O Card Interface

10.3.7 Waits between Access Cycles

A problem associated with higher external memory bus operating frequencies is that data buffer turn-off on completion of a read from a low-speed device may be too slow, causing a collision with data in the next access. This results in lower reliability or incorrect operation. To avoid this problem, a data collision prevention feature has been provided. This memorizes the preceding access area and the kind of read/write. If there is a possibility of a bus collision when the next access is started, a wait cycle is inserted before the access cycle thus preventing a data collision. There are two cases in which a wait cycle is inserted: when an access is followed by an access to a different area, and when a read access is followed by a write access from the SH7709S. When the SH7709S performs consecutive write cycles, the data transfer direction is fixed (from the SH7709S to other memory) and there is no problem. With read accesses to the same area, in principle, data is output from the same data buffer, and wait cycle insertion is not performed. Bits AnIW1 and AnIW0 ($n = 0, 2-6$) in WCR1 specify the number of idle cycles to be inserted between access cycles when a physical space area access is followed by an access to another area, or when the SH7709S performs a write access after a read access to physical space area n . If there is originally space between accesses, the number of idle cycles inserted is the specified number of idle cycles minus the number of empty cycles.

Waits are not inserted between accesses when bus arbitration is performed, since empty cycles are inserted for arbitration purposes.

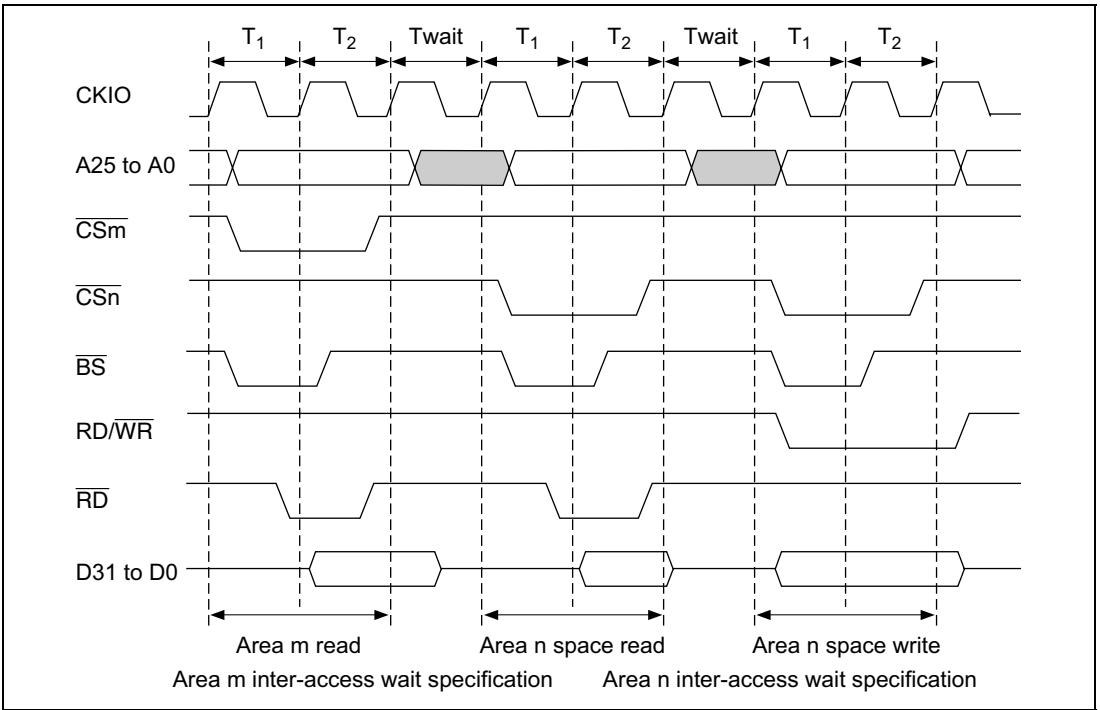

Figure 10.40 Waits between Access Cycles

10.3.8 Bus Arbitration

When a bus release request ($\overline{\text{BREQ}}$) is asserted from an external device, buses are released after the bus cycle being executed is completed and a bus grant signal ($\overline{\text{BACK}}$) is output. The bus is not released during burst transfers for cache fills or write-back, or TAS instruction execution between the read cycle and write cycle. Bus arbitration is not executed in multiple bus cycles that are generated when the data bus width is shorter than the access size; i.e. in the bus cycles when longword access is executed for the 8-bit memory. At the negation of $\overline{\text{BREQ}}$, $\overline{\text{BACK}}$ is negated and bus use is restarted. See Appendix A.1, Pin States, for the pin states when the bus is released.

The SH7709S sometimes needs to retrieve a bus it has released. For example, when memory generates a refresh request or an interrupt request internally, the SH7709S must perform the appropriate processing. The SH7709S has a bus request signal ($\overline{\text{IRQOUT}}$) for this purpose. When it must retrieve the bus, it asserts the $\overline{\text{IRQOUT}}$ signal. Devices asserting an external bus release request receive the assertion of the $\overline{\text{IRQOUT}}$ signal and negate the $\overline{\text{BREQ}}$ signal to release the bus. The SH7709S retrieves the bus and carries out the processing.

IRQOUT Pin Assertion Conditions:

- When a memory refresh request has been generated but the refresh cycle has not yet begun
- When an interrupt is generated with an interrupt request level higher than the setting of the interrupt mask bits (I3–I0) in the status register (SR). (This does not depend on the SR.BL bit.)

10.3.9 Bus Pull-Up

With the SH7709S, address pin pull-up can be performed when the bus is released by setting the PULA bit in BCR1 to 1. The address pins are pulled up for a 4-clock period after $\overline{\text{BACK}}$ is asserted. Figure 10.41 shows the address pin pull-up timing. Similarly, data pin pull-up can be performed by setting the PULD bit in BCR1 to 1. The data pins should be pulled up when the data bus is not in use. The data pin pull-up timing for a read cycle is shown in figure 10.42, and the timing for a write cycle in figure 10.43.

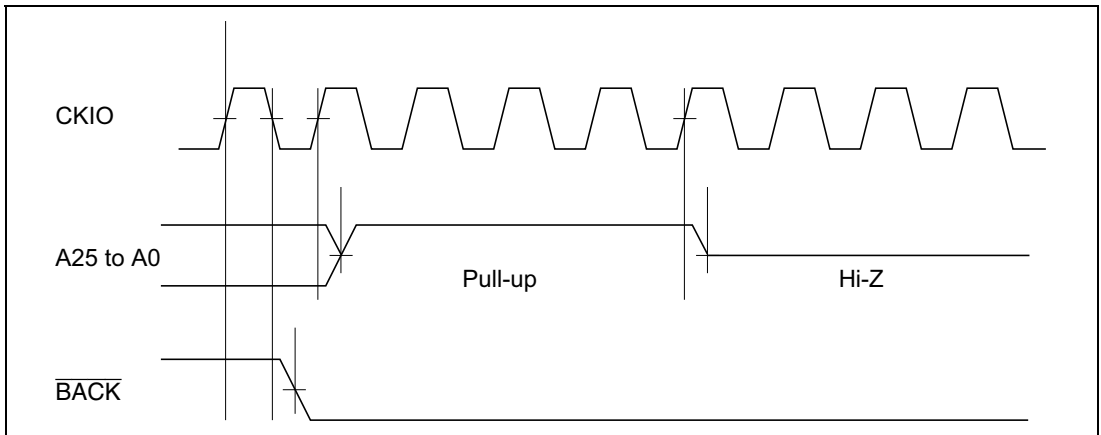

Figure 10.41 Pull-Up Timing for Pins A25 to A0

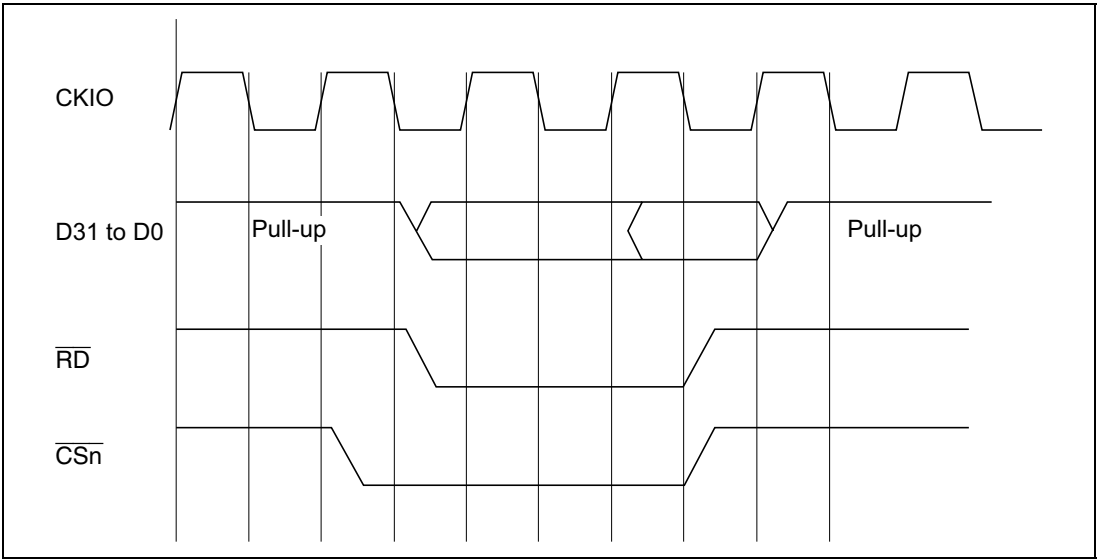

Figure 10.42 Pull-Up Timing for Pins D31 to D0 (Read Cycle)

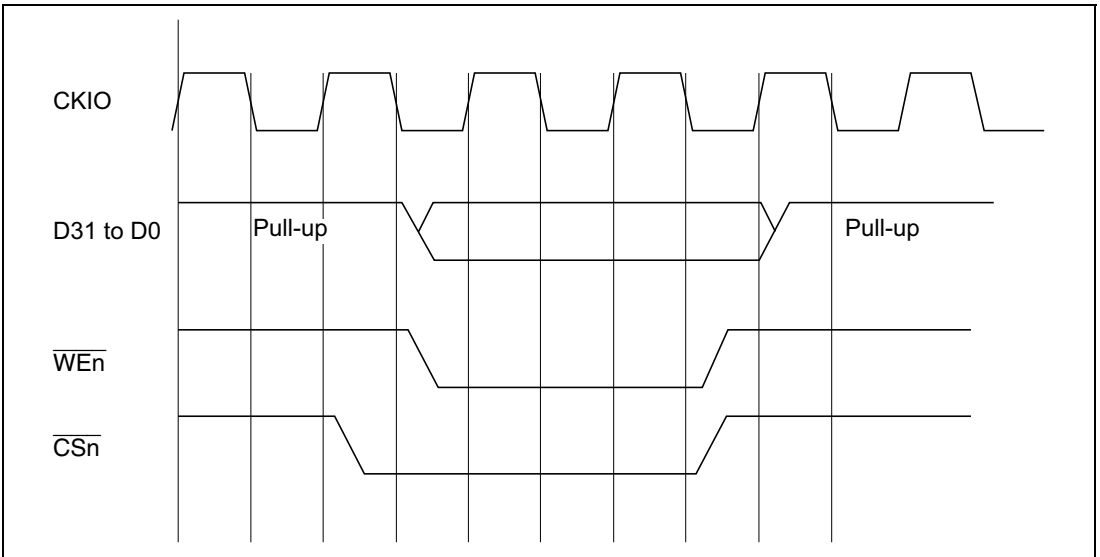

Figure 10.43 Pull-Up Timing for Pins D31 to D0 (Write Cycle)

10.3.10 $\overline{\text{MCS}}[0]$ to $\overline{\text{MCS}}[7]$ Pin Control

The SH7709S is provided with pins $\overline{\text{MCS}}[0]$ – $\overline{\text{MCS}}[7]$ as dedicated $\overline{\text{CS}}$ pins for the ROM connected to area 0 or 2. Assertion of $\overline{\text{MCS}}[0]$ – $\overline{\text{MCS}}[7]$ is controlled by settings in MCSCR0–MCSCR7. This enables 32-, 64-, 128-, or 256-Mbit memory to be connected to area 0 or area 2. However, only CS2/0 = 0 (area 0) should be used for MCSCR0. Table 10.15 shows MCSCR0–MCSCR7 settings and $\overline{\text{MCS}}[0]$ – $\overline{\text{MCS}}[7]$ assertion conditions.

As the $\overline{\text{MCS}}[0]$ – $\overline{\text{MCS}}[7]$ pins are multiplexed as the PTC0–PTC7 pins, when using these pins as $\overline{\text{MCS}}[0]$ – $\overline{\text{MCS}}[7]$, the corresponding bits in the PCCR register should be set to “other function.”

When CS2/0 = 0 in the MCSCR0 and when the PTC0 pin is switched to $\overline{\text{MCS}}[0]$ (when PCOMD1–PCOMD0 are set to “other function”), the $\overline{\text{CS}}0$ pin is also switched to $\overline{\text{MCS}}[0]$.

As port register writes operate on the peripheral clock, they take time compared with instruction execution by the CPU operating on the high-speed internal clock. Therefore, if an instruction that accesses $\overline{\text{MCS}}[1]$ to $\overline{\text{MCS}}[7]$ is located several instructions after an instruction that switches port C to $\overline{\text{MCS}}$, the switch from PTC[n] to $\overline{\text{MCS}}n$ and from $\overline{\text{CS}}0$ to $\overline{\text{MCS}}[0]$ may not be performed correctly.

To prevent this problem, the following switching procedure should be used.

- When the program runs with cache on
 - (1) To switch port C to $\overline{\text{MCS}}$, set the corresponding bits in the PCCR register to 00 (“other function”).
 - (2) Read the PCCR register and check whether the set value is read. Repeat until the set value is read.
 - (3) Perform a dummy read from non-cacheable $\overline{\text{CS}}0$ space (e.g. address H'A0000000). This will result in an access to the $\overline{\text{CS}}0$ space, and immediately afterward, $\overline{\text{CS}}0$ will be switched to $\overline{\text{MCS}}[0]$, and port C[n] will be switched to $\overline{\text{MCS}}[n]$.
 - (4) Access can now be made to the $\overline{\text{MCS}}[1]$ to $\overline{\text{MCS}}[7]$ spaces.
- When the program runs in $\overline{\text{MCS}}[0]$ space with cache off
 - (1) Set the PCCR register as in (1) above.
 - (2) Place at least three NOP instructions after the instruction in (1). As a result, when the PCCR register is rewritten, an access to the $\overline{\text{CS}}0$ space will be generated, and immediately afterward, $\overline{\text{CS}}0$ will be switched to $\overline{\text{MCS}}[0]$, and port C[n] will be switched to $\overline{\text{MCS}}[n]$.
 - (3) Access can now be made to the $\overline{\text{MCS}}[1]$ to $\overline{\text{MCS}}[7]$ spaces.

Table 10.15 MCSCRx Settings and $\overline{\text{MCS}}[x]$ Assertion Conditions (x: 0–7)

MCSCRx Settings							$\overline{\text{MCS}}[x]$ Assertion Conditions			Notes
CS2/0	CAP1	CAP0	A25	A24	A23	A22	$\overline{\text{CS}}0$	$\overline{\text{CS}}2$	Address Bus A [25:0]	
0	1	1	0	—	—	—	L	H	H'0000000 to H'1FFFFFFF	256-Mbit ROM
			1	—	—	—	L	H	H'2000000 to H'3FFFFFFF	
1	0	0	0	0	—	—	L	H	H'0000000 to H'0FFFFFFF	128-Mbit ROM
			0	1	—	—	L	H	H'1000000 to H'1FFFFFFF	
			1	0	—	—	L	H	H'2000000 to H'2FFFFFFF	
			1	1	—	—	L	H	H'3000000 to H'3FFFFFFF	
0	1	0	0	0	0	—	L	H	H'0000000 to H'07FFFFFFF	64-Mbit ROM
			0	0	1	—	L	H	H'0800000 to H'0FFFFFFF	
			0	1	0	—	L	H	H'1000000 to H'17FFFFFFF	
			0	1	1	—	L	H	H'1800000 to H'1FFFFFFF	
			1	0	0	—	L	H	H'2000000 to H'27FFFFFFF	
			1	0	1	—	L	H	H'2800000 to H'2FFFFFFF	
			1	1	0	—	L	H	H'3000000 to H'37FFFFFFF	
			1	1	1	—	L	H	H'3800000 to H'3FFFFFFF	
0	0	0	0	0	0	0	L	H	H'0000000 to H'03FFFFFFF	32-Mbit ROM
			0	0	0	1	L	H	H'0400000 to H'07FFFFFFF	
			0	0	1	0	L	H	H'0800000 to H'0BFFFFFFF	
			0	0	1	1	L	H	H'0C00000 to H'0FFFFFFF	
			0	1	0	0	L	H	H'1000000 to H'13FFFFFFF	
			0	1	0	1	L	H	H'1400000 to H'17FFFFFFF	
			0	1	1	0	L	H	H'1800000 to H'1BFFFFFFF	
			0	1	1	1	L	H	H'1C00000 to H'1FFFFFFF	
			1	0	0	0	L	H	H'2000000 to H'23FFFFFFF	
			1	0	0	1	L	H	H'2400000 to H'27FFFFFFF	
			1	0	1	0	L	H	H'2800000 to H'2BFFFFFFF	
			1	0	1	1	L	H	H'2C00000 to H'2FFFFFFF	
			1	1	0	0	L	H	H'3000000 to H'33FFFFFFF	
			1	1	0	1	L	H	H'3400000 to H'37FFFFFFF	
1	1	1	0	L	H	H'3800000 to H'3BFFFFFFF				
1	1	1	1	L	H	H'3C00000 to H'3FFFFFFF				

MCSCRx Settings							MCS[x] Assertion Conditions				Notes
CS2/0	CAP1	CAP0	A25	A24	A23	A22	CS0	CS2	Address Bus A[25:0]		
1	1	1	0	—	—	—	H	L	H'0000000 to H'1FFFFFFF	256-Mbit ROM	
			1	—	—	—	H	L	H'2000000 to H'3FFFFFFF		
1	0	0	0	—	—	—	H	L	H'0000000 to H'0FFFFFFF	128-Mbit ROM	
			0	1	—	—	H	L	H'1000000 to H'1FFFFFFF		
			1	0	—	—	H	L	H'2000000 to H'2FFFFFFF		
			1	1	—	—	H	L	H'3000000 to H'3FFFFFFF		
0	1	0	0	0	0	—	H	L	H'0000000 to H'07FFFFFFF	64-Mbit ROM	
			0	0	1	—	H	L	H'0800000 to H'0FFFFFFF		
			0	1	0	—	H	L	H'1000000 to H'17FFFFFFF		
			0	1	1	—	H	L	H'1800000 to H'1FFFFFFF		
			1	0	0	—	H	L	H'2000000 to H'27FFFFFFF		
			1	0	1	—	H	L	H'2800000 to H'2FFFFFFF		
			1	1	0	—	H	L	H'3000000 to H'37FFFFFFF		
			1	1	1	—	H	L	H'3800000 to H'3FFFFFFF		
0	0	0	0	0	0	0	H	L	H'0000000 to H'03FFFFFFF	32-Mbit ROM	
			0	0	0	1	H	L	H'0400000 to H'07FFFFFFF		
			0	0	1	0	H	L	H'0800000 to H'0BFFFFFFF		
			0	0	1	1	H	L	H'0C00000 to H'0FFFFFFF		
			0	1	0	0	H	L	H'1000000 to H'13FFFFFFF		
			0	1	0	1	H	L	H'1400000 to H'17FFFFFFF		
			0	1	1	0	H	L	H'1800000 to H'1BFFFFFFF		
			0	1	1	1	H	L	H'1C00000 to H'1FFFFFFF		
			1	0	0	0	H	L	H'2000000 to H'23FFFFFFF		
			1	0	0	1	H	L	H'2400000 to H'27FFFFFFF		
			1	0	1	0	H	L	H'2800000 to H'2BFFFFFFF		
			1	0	1	1	H	L	H'2C00000 to H'2FFFFFFF		
			1	1	0	0	H	L	H'3000000 to H'33FFFFFFF		
			1	1	0	1	H	L	H'3400000 to H'37FFFFFFF		
			1	1	1	0	H	L	H'3800000 to H'3BFFFFFFF		
			1	1	1	1	H	L	H'3C00000 to H'3FFFFFFF		

Section 11 Direct Memory Access Controller (DMAC)

11.1 Overview

The SH7709S includes a four-channel direct memory access controller (DMAC). The DMAC can be used in place of the CPU to perform high-speed transfers between external devices that have DACK (transfer request acknowledge signal), external memory, memory-mapped external devices, and on-chip peripheral modules (IrDA, SCIF, A/D converter, and D/A converter). Using the DMAC reduces the burden on the CPU and increases overall operating efficiency.

11.1.1 Features

The DMAC has the following features.

- Four channels
- 4-GB address space in the architecture
- 16-byte transfer (In 16-byte transfer, four 32-bit reads are executed, followed by four 32-bit writes.)
- Choice of 8-bit, 16-bit, 32-bit, or 16-byte transfer data length
- 16 Mbytes (16,777,216 transfers)
- Address mode: Dual address mode and single address mode are supported. In addition, direct address transfer mode or indirect address transfer mode can be selected.
 - Dual address mode transfer: Both the transfer source and transfer destination are accessed by address. Dual address mode has direct address transfer mode and indirect address transfer mode.
 - Direct address transfer mode: The values specified in the DMAC registers indicates the transfer source and transfer destination. Two bus cycles are required for one data transfer.
 - Indirect address transfer mode: Data is transferred with the address stored prior to the address specified in the transfer source address in the DMAC. Other operations are the same as those of direct address transfer mode. This function is only available in channel 3. Four bus cycles are required for one data transfer.
 - Single address mode transfer: Either the transfer source or transfer destination peripheral device is accessed (selected) by means of the DACK signal, and the other device is accessed by address. One transfer unit of data is transferred in one bus cycle.
- Channel functions: The transfer mode that can be specified depends on the channel:
 - Channel 0: External request can be accepted.
 - Channel 1: External request can be accepted.
 - Channel 2: This channel has a source address reload function, which reloads a source address every four transfers.

- Channel 3: In this channel, direct address mode or indirect address transfer mode can be specified.
- Reload function: The value that was specified in the source address register can be automatically reloaded every four DMA transfers. This function is only available in channel 2.
- Transfer requests
 - External request (From two $\overline{\text{DREQ}}$ pins (channels 0 and 1 only). $\overline{\text{DREQ}}$ can be detected either by the falling edge or by low level.)
 - On-chip module request (Requests from on-chip peripheral modules such as serial communications interface (IrDA and SCIF), A/D converter (A/D) and a timer (CMT). This request can be accepted in all the channels.)
 - Auto request (The transfer request is generated automatically within the DMAC.)
- Selectable bus modes: Cycle-steal mode or burst mode
- Selectable channel priority levels:
 - Fixed mode: The channel priority is fixed.
 - Round-robin mode: The priority of the channel in which the execution request was accepted is made the lowest.
- Interrupt request: An interrupt request to the CPU can be generated after the specified number of transfers.

11.1.2 Block Diagram

Figure 11.1 shows a block diagram of the DMAC.

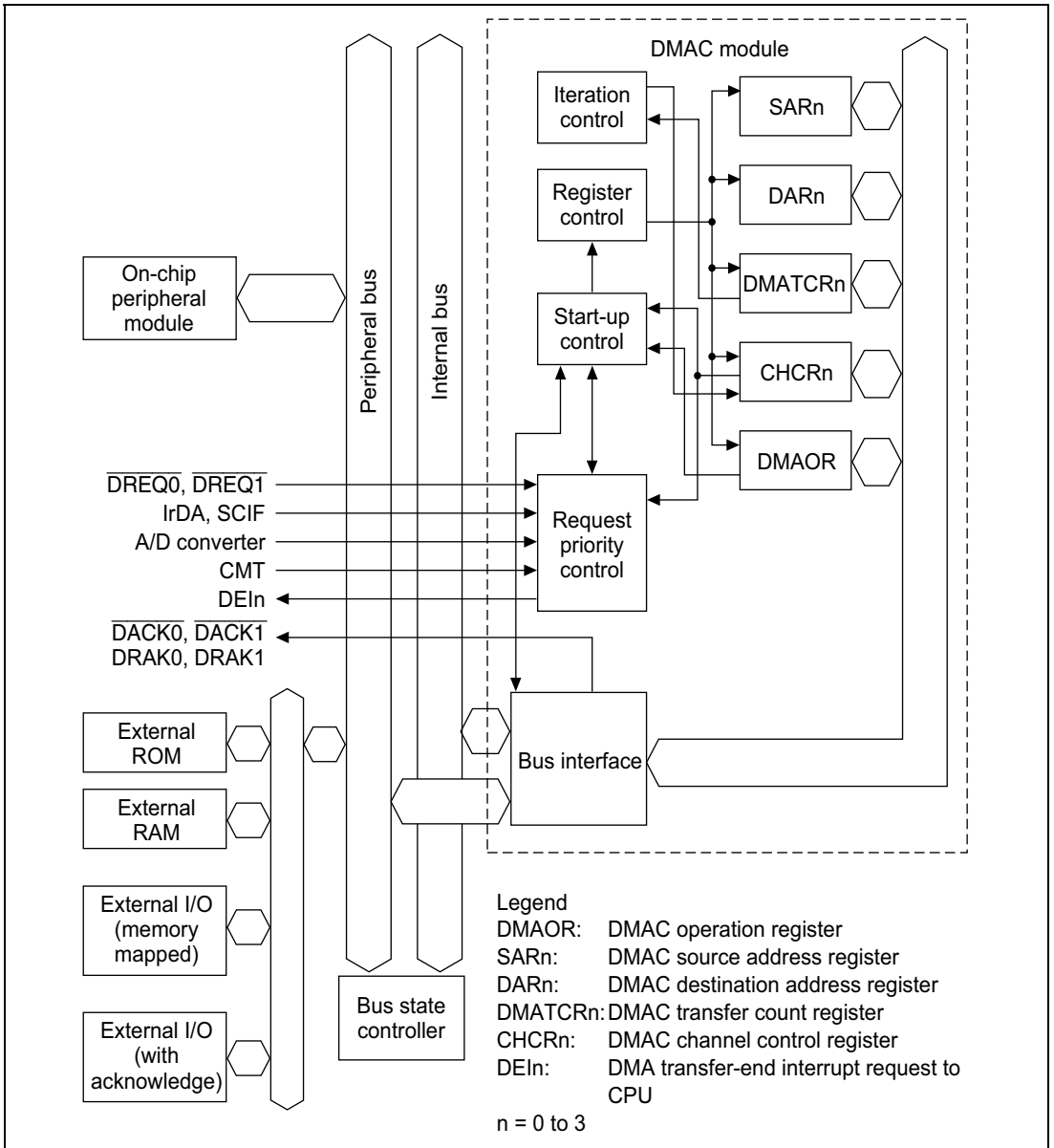

Figure 11.1 Block Diagram of DMAC

11.1.3 Pin Configuration

Table 11.1 shows the DMAC pins.

Table 11.1 DMAC Pins

Channel	Name	Symbol	I/O	Function
0	DMA transfer request	$\overline{\text{DREQ0}}$	I	DMA transfer request input from external device to channel 0
	DMA transfer request acceptance	DACK0	O	Strobe output to an external I/O upon DMA transfer request from external device to channel 0
	DMA request acknowledge	DRAK0	O	Output showing that DREQ0 has been accepted
1	DMA transfer request	$\overline{\text{DREQ1}}$	I	DMA transfer request input from external device to channel 1
	DMA transfer request acceptance	DACK1	O	Strobe output to an external I/O upon DMA transfer request from external device to channel 1
	DMA request acknowledge	DRAK1	O	Output showing that DREQ1 has been accepted

11.1.4 Register Configuration

Table 11.2 summarizes the DMAC registers. The DMAC has a total of 17 registers: each channel has four registers, and one overall DMAC control register.

Table 11.2 DMAC Registers

Channel	Name	Abbreviation	R/W	Initial Value	Address	Register Size	Access Size
0	DMA source address register 0	SAR0	R/W	Undefined	H'04000020 (H'A4000020) ^{*4}	32	16, 32 ^{*2}
	DMA destination address register 0	DAR0	R/W	Undefined	H'04000024 (H'A4000024) ^{*4}	32	16, 32 ^{*2}
	DMA transfer count register 0	DMATCR0	R/W	Undefined	H'04000028 (H'A4000028) ^{*4}	24	16, 32 ^{*3}
	DMA channel control register 0	CHCR0	R/W ^{*1}	H'00000000	H'0400002C (H'A400002C) ^{*4}	32	8, 16, 32 ^{*2}
1	DMA source address register 1	SAR1	R/W	Undefined	H'04000030 (H'A4000030) ^{*4}	32	16, 32 ^{*2}
	DMA destination address register 1	DAR1	R/W	Undefined	H'04000034 (H'A4000034) ^{*4}	32	16, 32 ^{*2}
	DMA transfer count register 1	DMATCR1	R/W	Undefined	H'04000038 (H'A4000038) ^{*4}	24	16, 32 ^{*3}
	DMA channel control register 1	CHCR1	R/W ^{*1}	H'00000000	H'0400003C (H'A400003C) ^{*4}	32	8, 16, 32 ^{*2}
2	DMA source address register 2	SAR2	R/W	Undefined	H'04000040 (H'A4000040) ^{*4}	32	16, 32 ^{*2}
	DMA destination address register 2	DAR2	R/W	Undefined	H'04000044 (H'A4000044) ^{*4}	32	16, 32 ^{*2}
	DMA transfer count register 2	DMATCR2	R/W	Undefined	H'04000048 (H'A4000048) ^{*4}	24	16, 32 ^{*3}
	DMA channel control register 2	CHCR2	R/W ^{*1}	H'00000000	H'0400004C (H'A400004C) ^{*4}	32	8, 16, 32 ^{*2}

Channel	Name	Abbreviation	R/W	Initial Value	Address	Register Size	Access Size
3	DMA source address register 3	SAR3	R/W	Undefined	H'04000050 (H'A4000050) ^{*4}	32	16, 32 ^{*2}
	DMA destination address register 3	DAR3	R/W	Undefined	H'04000054 (H'A4000054) ^{*4}	32	16, 32 ^{*2}
	DMA transfer count register 3	DMATCR3	R/W	Undefined	H'04000058 (H'A4000058) ^{*4}	24	16, 32 ^{*3}
	DMA channel control register 3	CHCR3	R/W ^{*1}	H'00000000	H'0400005C (H'A400005C) ^{*4}	32	8, 16, 32 ^{*2}
Shared	DMA operation register	DMAOR	R/W ^{*1}	H'0000	H'04000060 (H'A4000060) ^{*4}	16	8, 16 ^{*2}

Notes: These registers are located in area 1 of physical space. Therefore, when the cache is on, either access these registers from the P2 area of logical space or else make an appropriate setting using the MMU so that these registers are not cached.

1. Only 0 can be written to bit 1 of CHCR0 to CHCR3, and bits 1 and 2 of DMAOR to clear the flag after 1 is read.
2. If 16-bit access is used on SAR0 to SAR3, DAR0 to DAR3, and CHCR0 to CHCR3, the value in the 16 bits that were not accessed is retained.
3. DMATCR comprises the 24 bits from bit 0 to bit 23. The upper 8 bits, bits 24 to 31, cannot be written with 1 and are always read as 0.
4. When address translation by the MMU does not apply, the address in parentheses should be used.

11.2 Register Descriptions

11.2.1 DMA Source Address Registers 0–3 (SAR0–SAR3)

DMA source address registers 0–3 (SAR0–SAR3) are 32-bit readable/writable registers that specify the source address of a DMA transfer. During a DMA transfer, these registers indicate the next source address.

To transfer data in 16 bits or in 32 bits, specify a 16-bit or 32-bit address boundary address. When transferring data in 16-byte units, a 16-byte boundary (address 16n) must be set for the source address value. Operation is not guaranteed if other addresses are specified.

An undefined value will be returned in a reset. The previous value is retained in standby mode.

Bit:	31	30	29	28	27	26	25	24
Initial value:	—	—	—	—	—	—	—	—
R/W:	R/W	R/W	R/W	R/W	R/W	R/W	R/W	R/W
Bit:	23	22	21	20	0
Initial value:	—	—	—	—	—
R/W:	R/W	R/W	R/W	R/W	R/W

11.2.2 DMA Destination Address Registers 0–3 (DAR0–DAR3)

DMA destination address registers 0–3 (DAR0–DAR3) are 32-bit readable/writable registers that specify the destination address of a DMA transfer. These registers include a count function, and during a DMA transfer, these registers indicate the next destination address.

To transfer data in 16-bit or 32-bit units, make sure to specify a destination address with a 16-byte boundary (16n address).

An undefined value will be returned in a reset. The previous value is retained in standby mode.

Bit:	31	30	29	28	27	26	25	24																											
	<table border="1" style="width: 100%; height: 20px;"> <tr> <td style="width: 12.5%;"></td> <td style="width: 12.5%;"></td> <td style="width: 12.5%;"></td> <td style="width: 12.5%;"></td> <td style="width: 12.5%;"></td> <td style="width: 12.5%;"></td> <td style="width: 12.5%;"></td> <td style="width: 12.5%;"></td> <td style="width: 12.5%;"></td> <td style="width: 12.5%;"></td> <td style="width: 12.5%;"></td> <td style="width: 12.5%;"></td> <td style="width: 12.5%;"></td> <td style="width: 12.5%;"></td> <td style="width: 12.5%;"></td> <td style="width: 12.5%;"></td> <td style="width: 12.5%;"></td> </tr> </table>																																		
Initial value:	—	—	—	—	—	—	—	—	—	—	—	—	—	—	—	—	—	—																	
R/W:	R/W	R/W	R/W	R/W	R/W	R/W	R/W	R/W	R/W	R/W	R/W	R/W	R/W	R/W	R/W	R/W	R/W	R/W																	
Bit:	23	22	21	20		...												0																	
	<table border="1" style="width: 100%; height: 20px;"> <tr> <td style="width: 12.5%;"></td> <td style="width: 12.5%;"></td> <td style="width: 12.5%;"></td> <td style="width: 12.5%;"></td> <td style="width: 12.5%;"></td> <td style="width: 12.5%;"></td> <td style="width: 12.5%;"></td> <td style="width: 12.5%;"></td> <td style="width: 12.5%;"></td> <td style="width: 12.5%;"></td> <td style="width: 12.5%;"></td> <td style="width: 12.5%;"></td> <td style="width: 12.5%;"></td> <td style="width: 12.5%;"></td> <td style="width: 12.5%;"></td> <td style="width: 12.5%;"></td> <td style="width: 12.5%;"></td> <td style="width: 12.5%;"></td> <td style="width: 12.5%;"></td> </tr> </table>																																		
Initial value:	—	—	—	—		...												—																	
R/W:	R/W	R/W	R/W	R/W		...												R/W																	

11.2.3 DMA Transfer Count Registers 0–3 (DMATCR0–DMATCR3)

DMA transfer count registers 0–3 (DMATCR0–DMATCR3) are 24-bit readable/writable registers that specify the DMA transfer count (bytes, words, or longwords). The number of transfers is 1 when the setting is H'000001, and 16,777,216 (the maximum) when H'000000 is set. During a DMA transfer, these registers indicate the remaining number of transfers.

In 16-byte transfer, one 16-byte transfer (128 bits) is counted as one.

Writing to upper eight bits in DMATCR is invalid; 0s are read if these bits are read. The write value should always be 0.

An undefined value will be returned in a reset. The previous value is retained in standby mode.

Bit:	31	30	29	28	27	26	25	24
Initial value:	—	—	—	—	—	—	—	—
R/W:	R	R	R	R	R	R	R	R
Bit:	23	22	21	20	0
Initial value:	—	—	—	—	—
R/W:	R/W	R/W	R/W	R/W	R/W

11.2.4 DMA Channel Control Registers 0–3 (CHCR0–CHCR3)

DMA channel control registers 0–3 (CHCR0–CHCR3) are 32-bit readable/writable registers that specify the operation mode, transfer method, etc., for each channel.

Bit 20 is only used in CHCR3; it is not used in CHCR0 to CHCR2. Consequently, writing to this bit is invalid in CHCR0 to CHCR2; 0 is read if this bit is read. Bit 19 is only used in CHCR2; it is not used in CHCR0, CHCR1, and CHCR3. Consequently, writing to this bit is invalid in CHCR0, CHCR1, and CHCR3; 0 is read if this bit is read. Bits 6 and 16 to 18 are only used in CHCR0 and CHCR1; they are not used in CHCR2 and CHCR3. Consequently, writing to these bits is invalid in CHCR2 and CHCR3; 0s are read if these bits are read.

These register values are initialized to 0 in a reset. The previous value is retained in standby mode.

Bit:	31	...	21	20	19	18	17	16
	—	...	—	DI	RO	RL	AM	AL
Initial value:	0	...	0	0	0	0	0	0
R/W:	R	...	R	(R/W) ^{*2}	(R/W) ^{*2}	(R/W) ^{*2}	(R/W) ^{*2}	(R/W) ^{*2}

Bit:	15	14	13	12	11	10	9	8
	DM1	DM0	SM1	SM0	RS3	RS2	RS1	RS0
Initial value:	0	0	0	0	0	0	0	0
R/W:	R/W	R/W	R/W	R/W	R/W	R/W	R/W	R/W

Bit:	7	6	5	4	3	2	1	0
	—	DS	TM	TS1	TS0	IE	TE	DE
Initial value:	0	0	0	0	0	0	0	0
R/W:	R	(R/W) ^{*2}	R/W	R/W	R/W	R/W	R/(W) ^{*1}	R/W

Notes: 1. Only 0 can be written to the TE bit after 1 is read.

2. The DI, RO, RL, AM, AL, and DS bits are not included in some channels.

Bits 31 to 21—Reserved: These bits are always read as 0. The write value should always be 0.

Bit 20—Direct/Indirect Selection (DI): Selects direct address mode or indirect address mode in channel 3.

This bit is only valid in CHCR3. Writing to this bit is invalid in CHCR0 to CHCR2; 0 is read if this bit is read. The write value should always be 0. When using 16-byte transfer, direct address mode must be specified. Operation is not guaranteed if indirect address mode is specified.

Bit 20: DI	Description
0	Direct address mode operation for channel 3 (Initial value)
1	Indirect address mode operation for channel 3

Bit 19—Source Address Reload Bit (RO): Selects whether the source address initial value is reloaded in channel 2.

This bit is only valid in CHCR2. Writing to this bit is invalid in CHCR0, CHCR1, and CHCR3; 0 is read if this bit is read. The write value should always be 0. When using 16-byte transfer, this bit must be cleared to 0, specifying non-reloading. Operation is not guaranteed if reloading is specified.

Bit 19: RO	Description
0	Source address is not reloaded (Initial value)
1	Source address is reloaded

Bit 18—Request Check Level Bit (RL): Specifies whether DRAK ($\overline{\text{DREQ}}$ acknowledge) signal output is active-high or active-low.

This bit is only valid in CHCR0 and CHCR1. Writing to this bit is invalid in CHCR2 and CHCR3; 0 is read if this bit is read. The write value should always be 0.

Bit 18: RL	Description
0	Active-low DRAK output (Initial value)
1	Active-high DRAK output

Bit 17—Acknowledge Mode Bit (AM): Specifies whether DACK is output in the data read cycle or in the data write cycle in dual address mode.

DACK is always output in single address mode, regardless of this bit specification.

This bit is only valid in CHCR0 and CHCR1. Writing to this bit is invalid in CHCR2 and CHCR3; 0 is read if this bit is read. The write value should always be 0.

Bit 17: AM	Description
0	DACK output in read cycle (Initial value)
1	DACK output in write cycle

Bit 16—Acknowledge Level (AL): Specifies whether DACK (acknowledge) signal output is active-high or active-low.

This bit is only valid in CHCR0 and CHCR1. Writing to this bit is invalid in CHCR2 and CHCR3; 0 is read if this bit is read. The write value should always be 0.

Bit 16: AL	Description
0	Active-low DACK output (Initial value)
1	Active-high DACK output

Bits 15 and 14—Destination Address Mode Bits 1 and 0 (DM1, DM0): Select whether the DMA destination address is incremented, decremented, or left fixed.

Bit 15: DM1	Bit 14: DM0	Description
0	0	Fixed destination address (Initial value)
0	1	Destination address is incremented (+1 in 8-bit transfer, +2 in 16-bit transfer, +4 in 32-bit transfer, +16 in 16-byte transfer)
1	0	Destination address is decremented (−1 in 8-bit transfer, −2 in 16-bit transfer, −4 in 32-bit transfer; illegal setting in 16-byte transfer)
1	1	Setting prohibited

Bits 13 and 12—Source Address Mode Bits 1 and 0 (SM1, SM0): Select whether the DMA source address is incremented, decremented, or left fixed.

Bit 13: SM1	Bit 12: SM0	Description
0	0	Fixed source address (Initial value)
0	1	Source address is incremented (+1 in 8-bit transfer, +2 in 16-bit transfer, +4 in 32-bit transfer, +16 in 16-byte transfer)
1	0	Source address is decremented (−1 in 8-bit transfer, −2 in 16-bit transfer, −4 in 32-bit transfer; illegal setting in 16-byte transfer)
1	1	Setting prohibited

If the transfer source is specified by indirect address, specify the address holding the value of the address in which the data to be transferred is stored (i.e. the indirect address) in source address register 3 (SAR3).

Specification of SAR3 incrementing or decrementing in indirect address mode depends on the SM1 and SM0 settings. In this case, however, the SAR3 increment or decrement value is +4, −4, or fixed at 0, regardless of the transfer data size specified in TS1 and TS0.

Bits 11 to 8—Resource Select Bits 3 to 0 (RS3 to RS0): Specify which transfer requests will be sent to the DMAC.

Bit 11: RS3	Bit 10: RS2	Bit 9: RS1	Bit 8: RS0	Description
0	0	0	0	External request*, dual address mode (Initial value)
0	0	0	1	Setting prohibited
0	0	1	0	External request / Single address mode External address space → external device with DACK
0	0	1	1	External request / Single address mode External device with DACK → external address space
0	1	0	0	Auto request
0	1	0	1	Setting prohibited
0	1	1	0	Setting prohibited
0	1	1	1	Setting prohibited
1	0	0	0	Setting prohibited
1	0	0	1	Setting prohibited
1	0	1	0	IrDA transmission
1	0	1	1	IrDA reception
1	1	0	0	SCIF transmission
1	1	0	1	SCIF reception
1	1	1	0	A/D converter
1	1	1	1	CMT

Notes: When using 16-byte transfer, the following settings must not be made:

- 1010 IrDA transmission
- 1011 IrDA reception
- 1100 SCIF transmission
- 1101 SCIF reception
- 1110 A/D converter
- 1111 CMT

Operation is not guaranteed if these settings are made.

* External request specification is valid only in channels 0 and 1. None of the request sources can be selected in channels 2 and 3.

Bit 6— $\overline{\text{DREQ}}$ Select Bit (DS): Selects low-level or falling-edge detection as the sampling method for the $\overline{\text{DREQ}}$ pin used in external request mode.

This bit is only valid in CHCR0 and CHCR1. Writing to this bit is invalid in CHCR2 and CHCR3; 0 is read if this bit is read. The write value should always be 0.

In channels 0 and 1, if an on-chip peripheral module is specified as a transfer request source or an auto-request is specified, the specification of this bit is ignored and falling-edge detection is fixed except in an auto-request.

Bit 6: DS	Description
0	$\overline{\text{DREQ}}$ detected by low level (Initial value)
1	$\overline{\text{DREQ}}$ detected at falling edge

Bit 5—Transmit Mode (TM): Specifies the bus mode when transferring data.

Bit 5: TM	Description
0	Cycle-steal mode (Initial value)
1	Burst mode

Bits 4 and 3—Transmit Size Bits 1 and 0 (TS1, TS0): Specify the size of data to be transferred.

Bit 4: TS1	Bit 3: TS0	Description
0	0	Byte size (8 bits) (Initial value)
0	1	Word size (16 bits)
1	0	Longword size (32 bits)
1	1	16-byte unit (4 longword transfers)

Bit 2—Interrupt Enable Bit (IE): If this bit is set to 1, an interrupt is requested on completion of the number of data transfers specified in DMATCR (i.e. when TE = 1).

Bit 2: IE	Description
0	Interrupt request is not generated on completion of data transfers specified in DMATCR (Initial value)
1	Interrupt request is generated on completion of data transfers specified in DMATCR

Bit 1—Transfer End Bit (TE): Set to 1 on completion of the number of data transfers specified in DMATCR. At this time, if the IE bit is set to 1, an interrupt request is generated.

If data transfer ends due to an NMI interrupt, a DMAC address error, or clearing of the DE bit or the DME bit in DMAOR before this bit is set to 1, this bit will not be set to 1. Even if the DE bit is set to 1 while this bit is set to 1, transfer is not enabled.

Bit 1: TE	Description
0	Data transfers specified in DMATCR not completed (Initial value) Clearing conditions: Writing 0 to TE after reading TE = 1 Power-on reset, manual reset
1	Data transfers specified in DMATCR completed

Bit 0—DMAC Enable Bit (DE): Enables operation of the corresponding channel.

Bit 0: DE	Description
0	Channel operation disabled (Initial value)
1	Channel operation enabled

If an auto-request is specified (RS3 to RS0), transfer starts when this bit is set to 1. In an external request or an internal module request, transfer starts when a transfer request is generated after this bit is set to 1. Clearing this bit during transfer terminates the transfer.

Even if the DE bit is set, transfer is not enabled if the TE bit is 1, the DME bit in DMAOR is 0, or the NMIF or AE bit in DMAOR is 1.

11.2.5 DMA Operation Register (DMAOR)

The DMA operation register (DMAOR) is a 16-bit readable/writable register that controls the DMAC transfer mode.

These register values are initialized to 0 in a reset. The previous value is retained in standby mode.

Bit:	15	14	13	12	11	10	9	8
	—	—	—	—	—	—	PR1	PR0
Initial value:	0	0	0	0	0	0	0	0
R/W:	R	R	R	R	R	R	R/W	R/W
Bit:	7	6	5	4	3	2	1	0
	—	—	—	—	—	AE	NMIF	DME
Initial value:	0	0	0	0	0	0	0	0
R/W:	R	R	R	R	R	R/(W)*	R/(W)*	R/W

Note: * Only 0 can be written to the AE and NMIF bits after 1 is read.

Bits 15 to 10—Reserved: These bits are always read as 0. The write value should always be 0.

Bits 9 and 8—Priority Mode Bits 1 and 0 (PR1, PR0): Select the priority level between channels when there are simultaneous transfer requests for multiple channels.

Bit 9: PR1	Bit 8: PR0	Description
0	0	CH0 > CH1 > CH2 > CH3 (Initial value)
0	1	CH0 > CH2 > CH3 > CH1
1	0	CH2 > CH0 > CH1 > CH3
1	1	Round-robin

Bits 7 to 3—Reserved: These bits are always read as 0. The write value should always be 0.

Bit 2—Address Error Flag Bit (AE): Indicates that an address error occurred by the DMAC. If this bit is set during data transfer, transfers on all channels are suspended. The CPU cannot write 1 to this bit. This bit can only be cleared by writing 0 after reading 1.

Bit 2: AE	Description
0	No DMAC address error; DMA transfer is enabled (Initial value) Clearing conditions: Writing 0 to AE after reading AE = 1 Power-on reset, manual reset
1	DMAC address error; DMA transfer is disabled This bit is set by occurrence of a DMAC address error

Bit 1—NMI Flag Bit (NMIF): Indicates that an NMI is input. This bit is set regardless of whether the DMAC is in the operating or halted state. The CPU cannot write 1 to this bit. Only 0 can be written to clear this bit after 1 is read.

Bit 1: NMIF	Description
0	No NMI input; DMA transfer is enabled (Initial value) Clearing conditions: Writing 0 to NMIF after reading NMIF = 1 Power-on reset, manual reset
1	NMI input; DMA transfer is disabled This bit is set by occurrence of an NMI interrupt

Bit 0—DMA Master Enable Bit (DME): Enables or disables the DMAC on all channels. If the DME bit and the DE bit corresponding to each channel in CHCR are set to 1, transfer is enabled on the corresponding channel. If this bit is cleared during transfer, transfer on all the channels will be terminated.

Even if the DME bit is set, transfer is not enabled if the TE bit is 1 or the DE bit is 0 in CHCR, or the NMIF or AE bit is 1 in DMAOR.

Bit 0: DME	Description
0	DMA transfer disabled on all channels (Initial value)
1	DMA transfer enabled on all channels

11.3 Operation

When there is a DMA transfer request, the DMAC starts the transfer according to the predetermined channel priority order; when the transfer end conditions are satisfied, it ends the transfer. Transfers can be requested in three modes: auto-request, external request, and on-chip module request. The dual address mode has direct address transfer mode and indirect address transfer mode. Burst mode or cycle-steal mode can be selected as the bus mode.

11.3.1 DMA Transfer Flow

After the DMA source address register (SAR), DMA destination address register (DAR), DMA transfer count register (DMATCR), DMA channel control register (CHCR), and DMA operation register (DMAOR) are set, the DMAC transfers data according to the following procedure:

1. Checks to see if transfer is enabled ($DE = 1$, $DME = 1$, $TE = 0$, $AE = 0$, $NMIF = 0$)
2. When a transfer request comes and transfer is enabled, the DMAC transfers 1 transfer unit of data (according to the TS0 and TS1 settings). For an auto-request, the transfer begins automatically when the DE bit and DME bit are set to 1. The DMATCR value will be decremented for each transfer. The actual transfer flows vary by address mode and bus mode.
3. When the specified number of transfers have been completed (when DMATCR reaches 0), the transfer ends normally. If the IE bit in CHCR is set to 1 at this time, a DEI interrupt is sent to the CPU.
4. When an address error occurs by the DMAC or an NMI interrupt is generated, the transfer is aborted.

Figure 11.2 is a flowchart of this procedure.

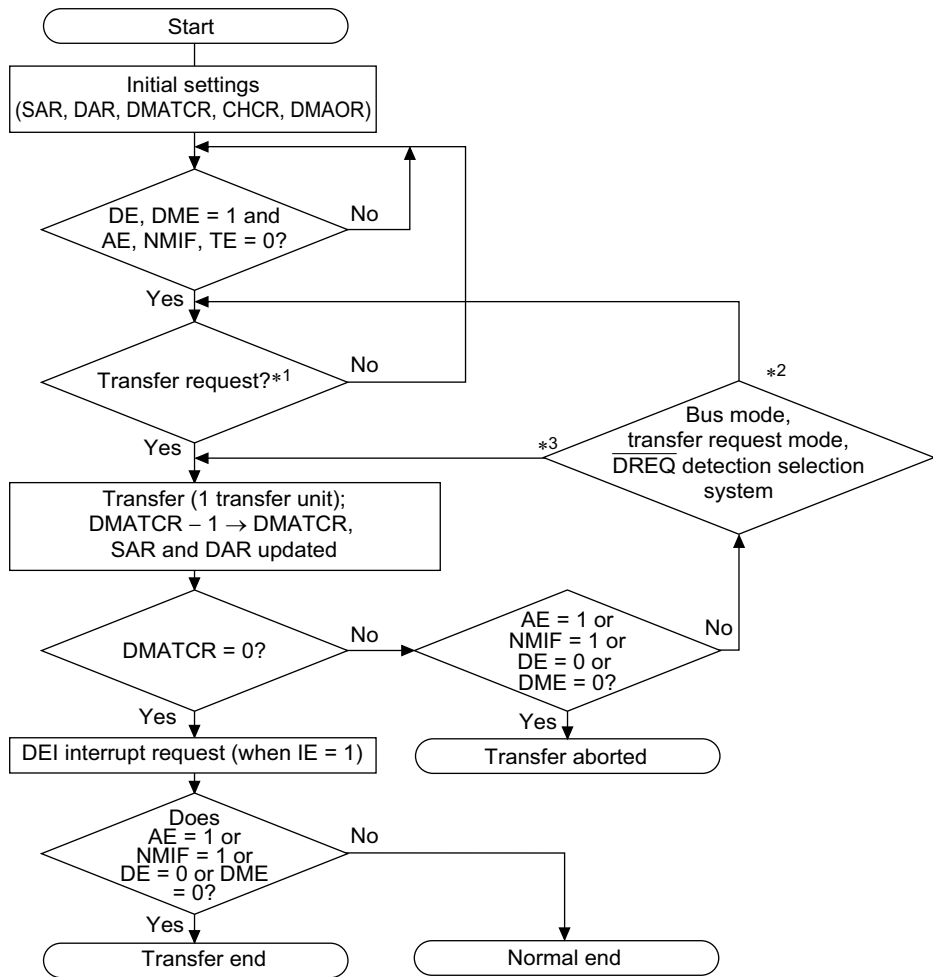

- Notes: 1. In auto-request mode, transfer begins when AE, NMIF, and TE are both 0 and the DE and DME bits are set to 1.
2. $\overline{\text{DREQ}}$ = level detection in burst mode (external request) or cycle-steal mode.
3. $\overline{\text{DREQ}}$ = edge detection in burst mode (external request), or auto-request mode in burst mode.

Figure 11.2 DMAC Transfer Flowchart

11.3.2 DMA Transfer Requests

DMA transfer requests are basically generated in either the data transfer source or destination, but they can also be generated by devices and on-chip peripheral modules that are neither the source nor the destination. Transfers can be requested in three modes: auto-request, external request, and on-chip module request. The request mode is selected in the RS3–RS0 bits of DMA channel control registers 0–3 (CHCR0–CHCR3).

Auto-Request Mode: When there is no transfer request signal from an external source, as in a memory-to-memory transfer or a transfer between memory and an on-chip peripheral module unable to request a transfer, the auto-request mode allows the DMAC to automatically generate a transfer request signal internally. When the DE bit of CHCR0–CHCR3 and the DME bit of DMAOR are set to 1, the transfer begins so long as the TE bit of CHCR0–CHCR3 and the NMIF and AE bits of DMAOR are 0.

External Request Mode: In this mode a transfer is performed in response to the request signal ($\overline{\text{DREQ}}$) of an external device. Choose one of the modes shown in table 11.3 according to the application system. When this mode is selected, if DMA transfer is enabled (DE = 1, DME = 1, TE = 0, AE = 0, NMIF = 0), a transfer is performed upon a request at the $\overline{\text{DREQ}}$ input. Choose $\overline{\text{DREQ}}$ detection by either a falling edge or low level of the signal input with the DS bit in CHCR0 and CHCR1 (DS = 0 for level detection, DS = 1 for edge detection). The source of the transfer request does not have to be the data transfer source or destination.

Table 11.3 Selecting External Request Modes with RS Bits

RS3	RS2	RS1	RS0	Address Mode	Source	Destination
0	0	0	0	Dual address mode	Any*	Any*
		1	0	Single address mode	External memory, memory-mapped external device	External device with DACK
			1		External device with DACK	External memory, memory-mapped external device

Note: * External memory, memory-mapped external device, on-chip memory, on-chip peripheral module (This applies only to IrDA, SCIF, A/D converter, D/A converter, and I/O ports.)

On-Chip Module Request Mode: In this mode a transfer is performed in response to a transfer request signal (interrupt request signal) of an on-chip module. This mode cannot be set in case of 16-byte transfer. These are six transfer request signals: the receive-data-full interrupts (RXI) and the transmit-data-empty interrupts (TXI) from two serial communication interfaces (IrDA, SCIF), the A/D conversion end interrupt (ADI) of the A/D converter, and the compare match timer interrupt (CMI) of the CMT (table 11.4). When this mode is selected, if DMA transfer is enabled (DE = 1, DME = 1, TE = 0, AE = 0, NMIF = 0), a transfer is performed upon input of a transfer

request signal. The source of the transfer request does not have to be the data transfer source or destination. When RXI is set as the transfer request, however, the transfer source must be the SCI's receive data register (RDR). Likewise, when TXI is set as the transfer request, the transfer source must be the SCI's transmit data register (TDR). If the transfer requester is the A/D converter, the data transfer source must be the A/D data register (ADDR).

Table 11.4 Selecting On-Chip Peripheral Module Request Modes with RS3-0 Bits

RS3	RS2	RS1	RS0	DMA Transfer Request Source	DMA Transfer Request Signal	Source	Destination	Bus Mode
1	0	1	0	IrDA transmitter	TXI1 (IrDA transmit-data-empty interrupt transfer request)	Any*	TDR1	Cycle-steal
1	0	1	1	IrDA receiver	RXI1 (IrDA receive-data-full interrupt transfer request)	RDR1	Any*	Cycle-steal
1	1	0	0	SCIF transmitter	TXI2 (SCIF transmit-data-empty interrupt transfer request)	Any*	TDR2	Cycle-steal
1	1	0	1	SCIF receiver	RXI2 (SCIF receive-data-full interrupt transfer request)	RDR1	Any*	Cycle-steal
1	1	1	0	A/D converter	ADI (A/D conversion end interrupt)	ADDR	Any*	Cycle-steal
1	1	1	1	CMT	CMI (Compare match timer interrupt)	Any*	Any*	Burst/cycle-steal

ADDR: A/D data register of A/D converter

Note: * External memory, memory-mapped external device, on-chip peripheral module (This applies only to IrDA, SCIF, A/D converter, D/A converter, and I/O ports.)

When outputting transfer requests from on-chip peripheral modules, the appropriate interrupt enable bits must be set to output the interrupt signals.

If the interrupt request signal of the on-chip peripheral module is used as a DMA transfer request signal, an interrupt is not sent to the CPU.

The DMA transfer request signals in table 11.4 are automatically discontinued when the corresponding DMA transfer is performed. If cycle-steal mode is being employed, they are withdrawn at the first transfer; if burst mode is being used, they are discontinued at the last transfer.

11.3.3 Channel Priority

When the DMAC receives simultaneous transfer requests on two or more channels, it selects a channel according to a predetermined priority order. Two modes (fixed mode and round-robin mode) are selected by priority bits PR1 and PR0 in the DMA operation register (DMAOR).

Fixed Mode: In these modes, the priority order of the channels remain fixed. There are three kinds of fixed modes as follows:

CH0 > CH1 > CH2 > CH3

CH0 > CH2 > CH3 > CH1

CH2 > CH0 > CH1 > CH3

These are selected by the PR1 and PR0 bits in DMAOR.

Round-Robin Mode: Each time one word, byte, or longword is transferred on one channel, the priority order is rotated. The channel on which the transfer was just finished rotates to the bottom of the priority order. The round-robin mode operation is shown in figure 11.3. The priority of the round-robin mode is CH0 > CH1 > CH2 > CH3 immediately after reset.

(1) When channel 0 transfers

Initial priority order

CH0 > CH1 > CH2 > CH3

Channel 0 becomes lowest-priority.

Priority order after transfer

CH1 > CH2 > CH3 > CH0

(2) When channel 1 transfers

Initial priority order

CH0 > CH1 > CH2 > CH3

Channel 1 becomes lowest-priority.

The priority of channel 0, which was higher than channel 1, is also shifted.

Priority order after transfer

CH2 > CH3 > CH0 > CH1

(3) When channel 2 transfers

Initial priority order

CH0 > CH1 > CH2 > CH3

Channel 2 becomes lowest-priority.

The priority of channels 0 and 1, which were higher than channel 2, are also shifted. If immediately after there is a request to transfer channel 1 only, channel 1 becomes lowest-priority and the priority of channels 3 and 0, which were higher than channel 1, is also shifted.

Priority order after transfer

CH3 > CH0 > CH1 > CH2

Post-transfer priority order when there is an immediate transfer request to channel 1 only

CH2 > CH3 > CH0 > CH1

(4) When channel 3 transfers

Priority order after transfer

CH0 > CH1 > CH2 > CH3

Priority order does not change.

Priority order after transfer

CH0 > CH1 > CH2 > CH3

Figure 11.3 Round-Robin Mode

Figure 11.4 shows how the priority order changes when channel 0 and channel 3 transfers are requested simultaneously and a channel 1 transfer is requested during the channel 0 transfer. The DMAC operates as follows:

1. Transfer requests are generated simultaneously for channels 0 and 3.
2. Channel 0 has a higher priority than channel 3, so the channel 0 transfer begins first (channel 3 waits for transfer).
3. A channel 1 transfer request occurs during the channel 0 transfer (channels 1 and 3 are both waiting)
4. When the channel 0 transfer ends, channel 0 becomes lowest-priority.
5. At this point, channel 1 has a higher priority than channel 3, so the channel 1 transfer begins (channel 3 waits for transfer).
6. When the channel 1 transfer ends, channel 1 becomes lowest-priority.
7. The channel 3 transfer begins.
8. When the channel 3 transfer ends, channels 3 and 2 shift downward in priority so that channel 3 becomes the lowest-priority.

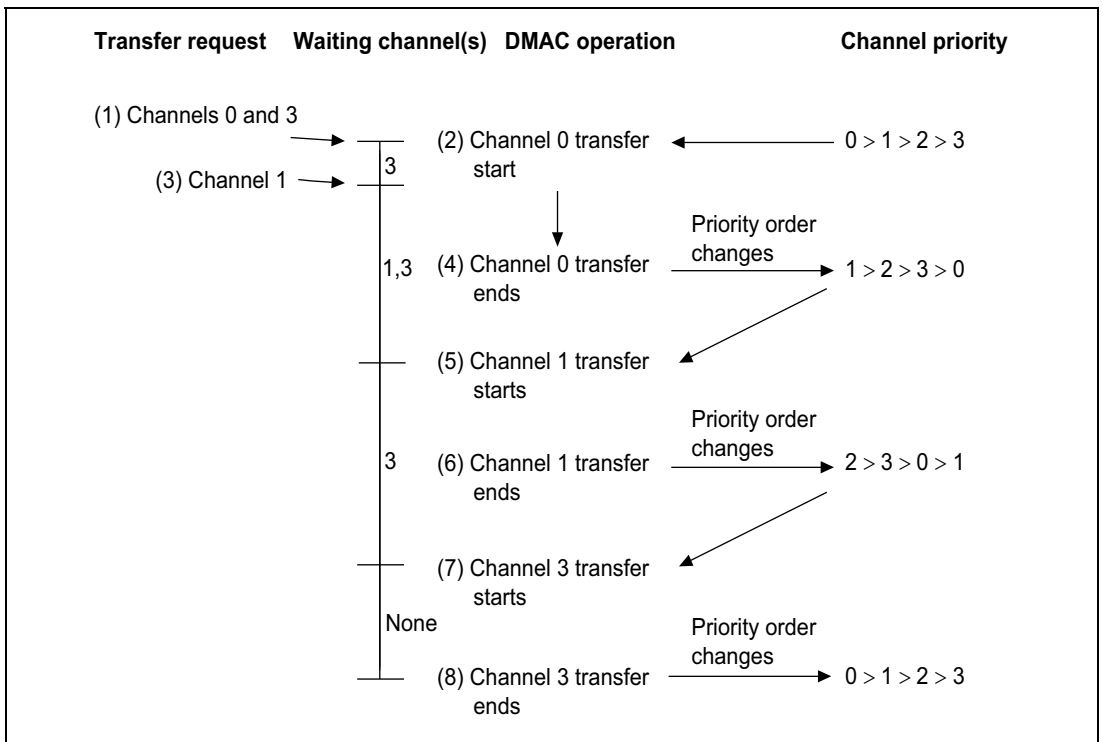

Figure 11.4 Changes in Channel Priority in Round-Robin Mode

11.3.4 DMA Transfer Types

The DMAC supports the transfers shown in table 11.5. Dual address mode has a direct address mode and indirect address mode. In direct address mode, an output address value is the data transfer target address; in indirect address mode, the value stored in the output address, not the output address value itself, is the data transfer target address. Data transfer timing depends on the bus mode, which may be cycle-steal mode or burst mode.

Table 11.5 Supported DMA Transfers

Source	Destination			
	External Device with DACK	External Memory	Memory-Mapped External Device	On-Chip Peripheral Module
External device with DACK	Not available	Dual, single	Dual, single	Not available
External memory	Dual, single	Dual	Dual	Dual
Memory-mapped external device	Dual, single	Dual	Dual	Dual
On-chip peripheral module	Not available	Dual	Dual	Dual

Notes: 1. Dual: Dual address mode
2. Single: Single address mode
3. Dual address mode includes direct address mode and indirect address mode.
4. 16-byte transfer is not available for on-chip peripheral modules.

Address Modes:

- Dual Address Mode

In dual address mode, both the transfer source and destination are accessed (selectable) by an address. The source and destination can be located externally or internally. Dual address mode has (1) a direct address transfer mode and (2) an indirect address transfer mode.

- (1) In direct address transfer mode, DMA transfer requires two bus cycles because data is read from the transfer source in a data read cycle and written to the transfer destination in a data write cycle. At this time, transfer data is temporarily stored in the DMAC. In the transfer between external memories as shown in figure 11.5, data is read to the DMAC from one external memory in a data read cycle, and then that data is written to the other external memory in a write cycle. Figure 11.6 shows an example of the timing at this time.

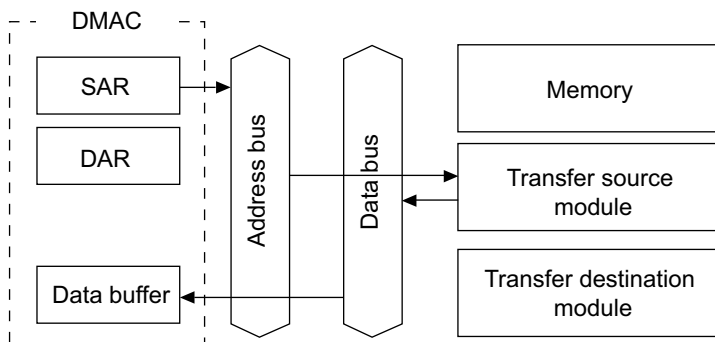

The SAR value is an address, data is read from the transfer source module, and the data is temporarily stored in the DMAC.

First bus cycle

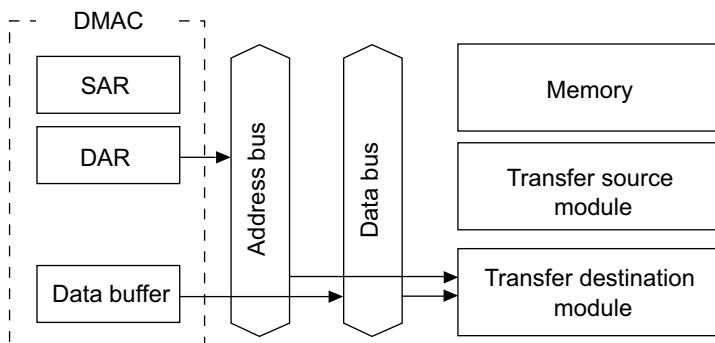

The DAR value is an address, and the value stored in the data buffer in the DMAC is written to the transfer destination module.

Second bus cycle

Figure 11.5 Operation of Direct Address Mode in Dual Address Mode

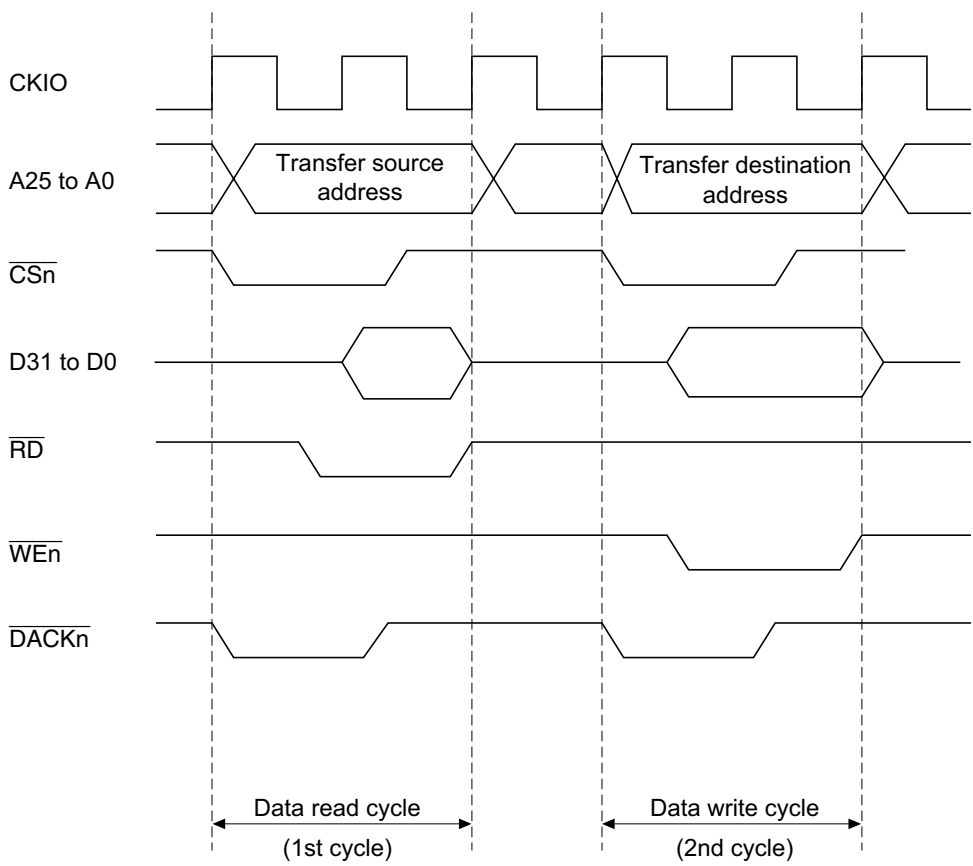

Note: In transfer between external memories, with DACK output in the read cycle, DACK output timing is the same as that of CSn.

Figure 11.6 Example of DMA Transfer Timing in the Direct Address Mode in Dual Mode (Transfer Source: Ordinary Memory, Transfer Destination: Ordinary Memory)

(2) In indirect address transfer mode, the address of memory in which data to be transferred is stored is specified in the transfer source address register (SAR3) in the DMAC. Consequently, in this mode, the address value specified in the transfer source address register in the DMAC is read first. This value is temporarily stored in the DMAC. Next, the read value is output as an address, and the value stored in that address is stored in the DMAC again. Then, the value read afterwards is written to the address specified in the transfer destination address; this completes one DMA transfer. 16-byte transfer is not possible.

Figure 11.7 shows an example. In this example, the transfer destination, the transfer source, and the storage destination of the indirect address are 16-bit external memories, and transfer data is 16 or 8 bits. Figure 11.8 shows an example of the transfer timing.

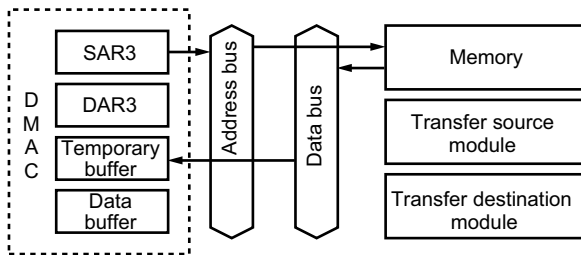

When the value in SAR3 is an address, the memory data is read and the value is stored in the temporary buffer. The value to be read must be 32 bits since it is used for the address. If data bus connected to an external memory space is 16 bits wide, two bus cycles are necessary.

First and second bus cycles

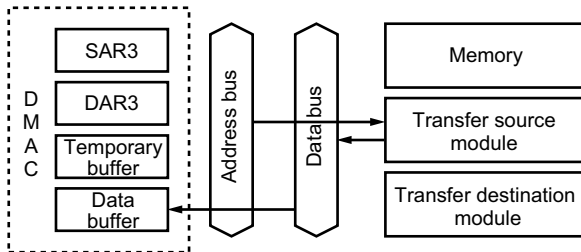

When the value in the temporary buffer is an address, the data is read from the transfer source module to the data buffer.

Third bus cycle

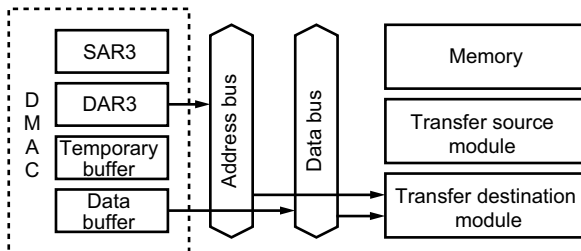

When the value in SAR3 is an address, the value in the data buffer is written to the transfer source module.

Fourth bus cycle

Note: This example shows memory, the transfer source module, and the transfer destination module; in practice, any module can be connected in the addressing space.

**Figure 11.7 Indirect Address Operation in Dual Address Mode
(When External Memory Space has a 16-Bit Width)**

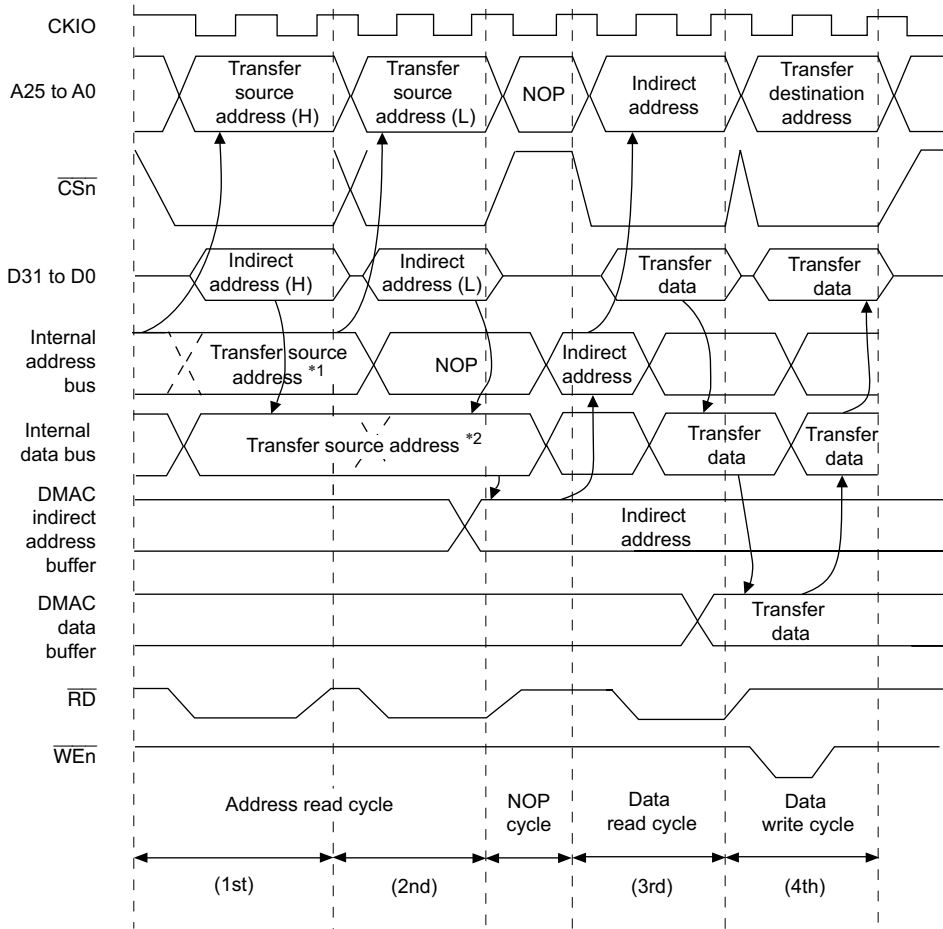

External memory space → external memory space (external memory is 16-bit width)

- Notes: 1. The internal address bus value does not change, and is controlled by the port.
 2. The DMAC does not fetch the value until 32-bit data is output to the internal data bus.

Figure 11.8 Example of Transfer Timing in the Indirect Address Mode in Dual Address Mode

- Single Address Mode

In single address mode, either the transfer source or transfer destination peripheral device is accessed (selected) by means of the DACK signal, and the other device is accessed by address. In this mode, the DMAC performs one DMA transfer in one bus cycle, accessing one of the external devices by outputting the DACK transfer request acknowledge signal to it, and at the same time outputting an address to the other device involved in the transfer. For example, in the case of transfer between external memory and an external device with DACK shown in figure 11.9, when the external device outputs data to the data bus, that data is written to the external memory in the same bus cycle.

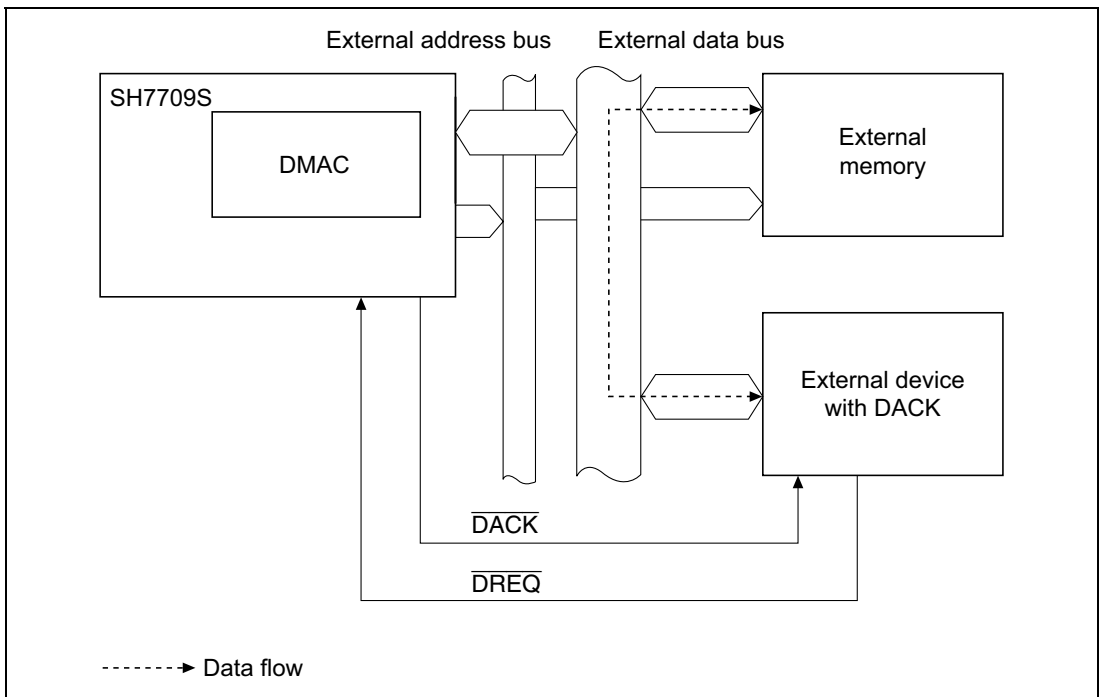
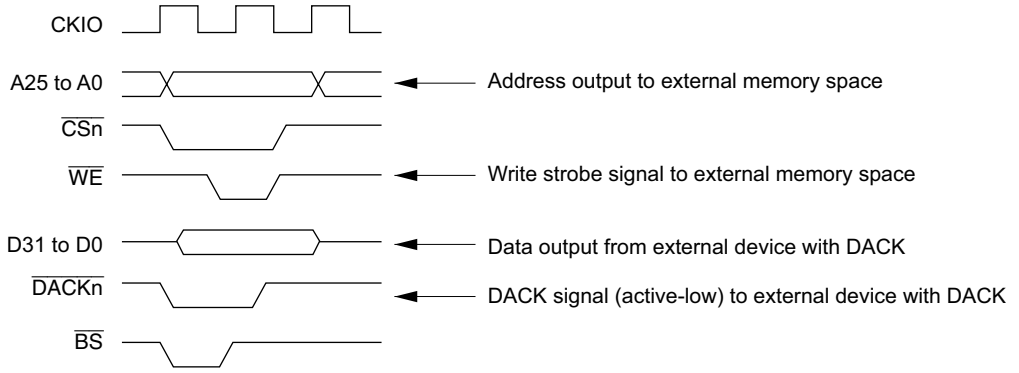

Figure 11.9 Data Flow in Single Address Mode

Two kinds of transfer are possible in single address mode: (1) transfer between an external device with DACK and a memory-mapped external device, and (2) transfer between an external device with DACK and external memory. In both cases, only the external request signal (\overline{DREQ}) is used for transfer requests.

Figures 11.10 and 11.11 show examples of DMA transfer timing in single address mode.



(a) External device with DACK → external memory space (ordinary memory)

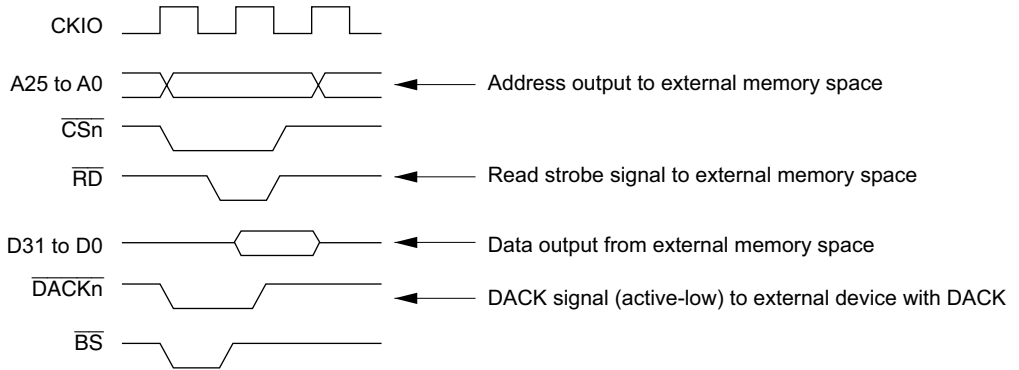

(b) External memory space (ordinary memory) → external device with DACK

Figure 11.10 Example of DMA Transfer Timing in Single Address Mode

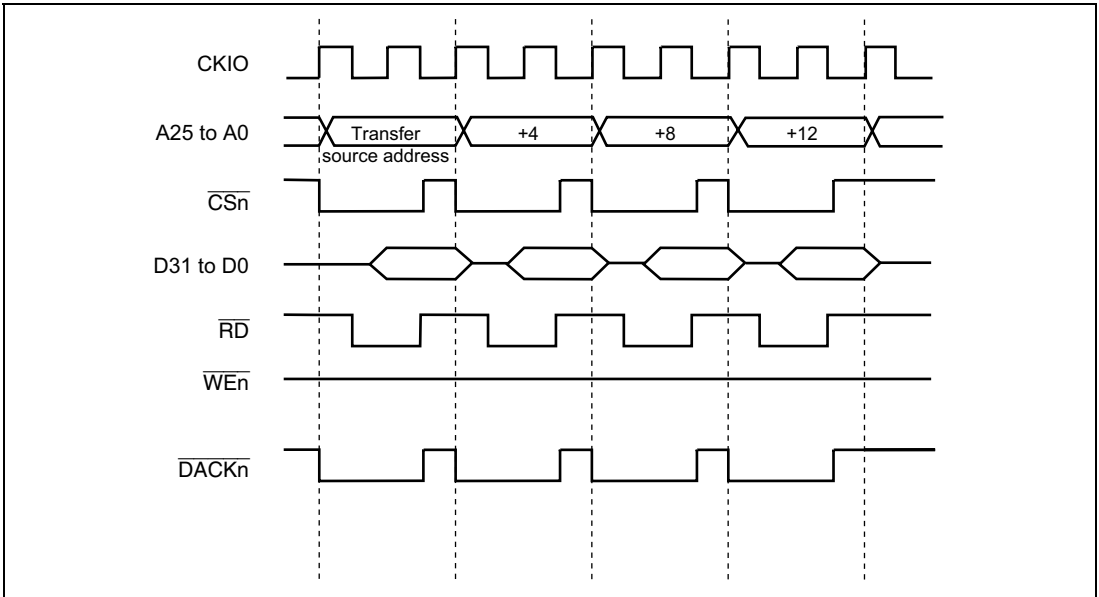

Figure 11.11 Example of DMA Transfer Timing in Single Address Mode (16-byte Transfer, External Memory Space (Ordinary Memory) → External Device with DACK)

Bus Modes: There are two bus modes: cycle-steal and burst. Select the mode in the TM bits of CHCR0–CHCR3.

- **Cycle-Steal Mode**

In cycle-steal mode, the bus is given to another bus master after a one-transfer-unit (byte, word, longword, or 16-byte unit) DMAC. When another transfer request occurs, the bus is obtained from the other bus master and transfer is performed for one transfer unit. When that transfer ends, the bus is passed to the other bus master. This is repeated until the transfer end conditions are satisfied.

In the cycle-steal mode, transfer areas are not affected regardless of the transfer request source, transfer source, and transfer destination settings. Figure 11.12 shows an example of DMA transfer timing in cycle-steal mode. Transfer conditions shown in the figure are:

- Dual address mode
- $\overline{\text{DREQ}}$ level detection

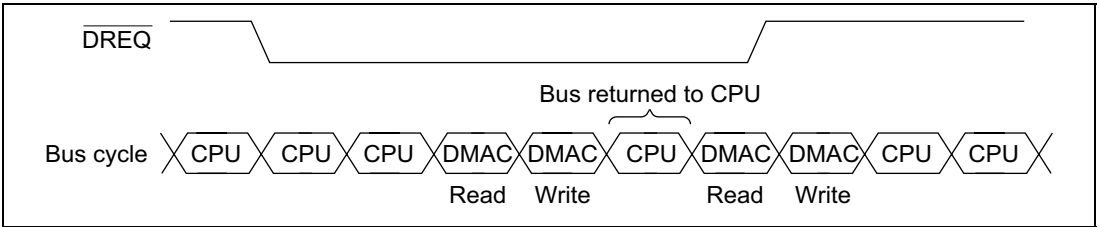

Figure 11.12 Example of DMA Transfer in Cycle-Steal Mode

- Burst Mode

Once the bus is obtained, the transfer is performed continuously until the transfer end condition is satisfied. In external request mode with low level detection of the $\overline{\text{DREQ}}$ pin, however, when the $\overline{\text{DREQ}}$ pin is driven high, the bus passes to the other bus master after the DMAC transfer request that has already been accepted ends, even if the transfer end conditions have not been satisfied.

Burst mode cannot be used when a serial communication interface (IrDA, SCI), or A/D converter is the transfer request source. Figure 11.13 shows an example of burst mode timing.

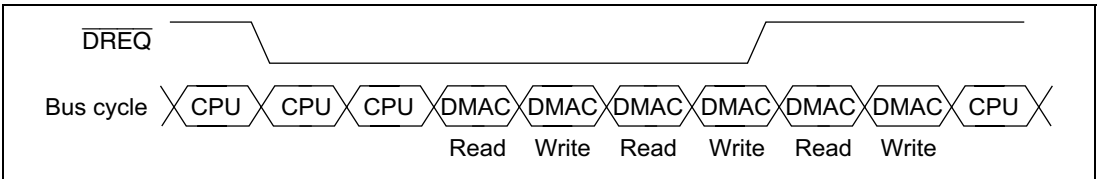

Figure 11.13 Example of Transfer in Burst Mode

Relationship between Request Modes and Bus Modes by DMA Transfer Category: Table 11.6 shows the relationship between request modes and bus modes by DMA transfer category.

Table 11.6 Relationship between Request Modes and Bus Modes by DMA Transfer Category

Address Mode	Transfer Category	Request Mode	Bus Mode	Transfer Size (Bits)	Usable Channels
Dual	External device with DACK and external memory	External	B/C	8/16/32/128	0, 1
	External device with DACK and memory-mapped external device	External	B/C	8/16/32/128	0, 1
	External memory and external memory	All ^{*1}	B/C	8/16/32/128	0–3 ^{*5}
	External memory and memory-mapped external device	All ^{*1}	B/C	8/16/32/128	0–3 ^{*5}
	Memory-mapped external device and memory-mapped external device	All ^{*1}	B/C	8/16/32/128	0–3 ^{*5}
	External memory and on-chip peripheral module	All ^{*2}	B/C ^{*3}	8/16/32 ^{*4}	0–3 ^{*5}
	Memory-mapped external device and on-chip peripheral module	All ^{*2}	B/C ^{*3}	8/16/32 ^{*4}	0–3 ^{*5}
	On-chip peripheral module and on-chip peripheral module	All ^{*2}	B/C ^{*3}	8/16/32 ^{*4}	0–3 ^{*5}
Single	External device with DACK and external memory	External	B/C	8/16/32/128	0, 1
	External device with DACK and memory-mapped external device	External	B/C	8/16/32/128	0, 1

B: Burst, C: Cycle-steal

- Notes:
1. External requests, auto requests and on-chip peripheral module (CMT) requests are all available.
 2. External requests, auto requests and on-chip peripheral module requests are all available. When the IrDA, SCIF, or A/D converter is also the transfer request source, however, the transfer destination or transfer source must be the IrDA, SCIF, or A/D converter, respectively.
 3. If the transfer request source is the IrDA, SCIF, or A/D converter only cycle-steal mode is available.
 4. The access size permitted when the transfer destination or source is an on-chip peripheral module register.
 5. If the transfer request is an external request, only channels 0 and 1 are available.

Bus Mode and Channel Priority Order: When, for example, channel 1 is transferring in burst mode and there is a transfer request to channel 0, which has higher priority, the channel 0 transfer will begin immediately.

At this time, if the priority is set in the fixed mode ($CH0 > CH1$), the channel 1 transfer will continue when the channel 0 transfer has completely finished, even if channel 0 is operating in cycle-steal mode or burst mode.

If the priority is set in round-robin mode, channel 1 will begin operating again after channel 0 completes the transfer of one transfer unit, even if channel 0 is in cycle-steal mode or burst mode. The bus will then switch between the two in the order channel 1, channel 0, channel 1, channel 0.

Even if the priority is set in fixed mode or in round-robin mode, the bus will not be given to the CPU since channel 1 is in burst mode. This example is illustrated in figure 11.14.

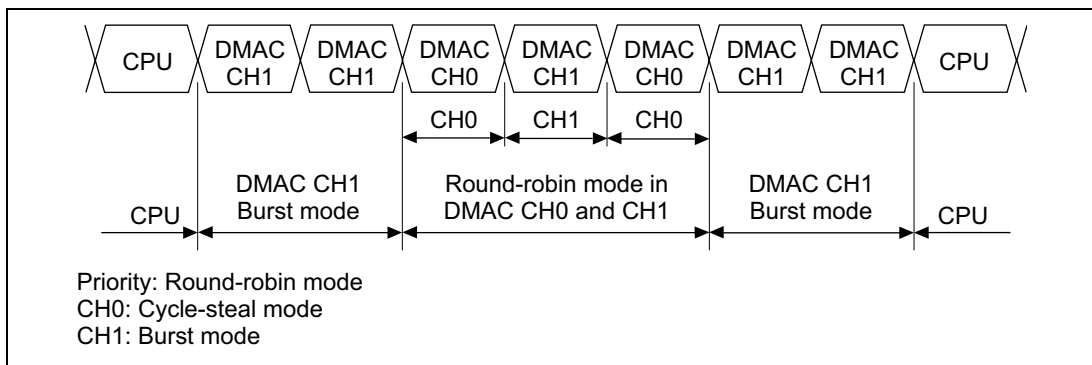

Figure 11.14 Bus State when Multiple Channels Are Operating

11.3.5 Number of Bus Cycle States and $\overline{\text{DREQ}}$ Pin Sampling Timing

Number of Bus Cycle States: When the DMAC is the bus master, the number of bus cycle states is controlled by the bus state controller (BSC) in the same way as when the CPU is the bus master. For details, see section 10, Bus State Controller (BSC).

$\overline{\text{DREQ}}$ Pin Sampling Timing: In external request mode, the $\overline{\text{DREQ}}$ pin is sampled by clock pulse (CKIO) falling edge or low level detection. When $\overline{\text{DREQ}}$ input is detected, a DMAC bus cycle is generated and DMA transfer performed, at the earliest, three states later.

The second and subsequent $\overline{\text{DREQ}}$ sampling operations are started two cycles after the first sample.

Operation

- Cycle-Steal Mode

In cycle-steal mode, the $\overline{\text{DREQ}}$ sampling timing is the same regardless of whether level or edge detection is used.

For example, in figure 11.15 (cycle-steal mode, level input), DMAC transfer begins, at the earliest, three cycles after the first sampling is performed. The second sampling is started two cycles after the first. If $\overline{\text{DREQ}}$ is not detected at this time, sampling is performed in each subsequent cycle.

Thus, $\overline{\text{DREQ}}$ sampling is performed one step in advance. The third sampling operation is not performed until the idle cycle following the end of the first DMA transfer.

The above conditions are the same whatever the number of CPU transfer cycles, as shown in figure 11.16. The above conditions are also the same whatever the number of DMA transfer cycles, as shown in figure 11.17.

DACK is output in a read in the example in figure 11.15, and in a write in the example in figure 11.16. In both cases, DACK is output for the same duration as $\overline{\text{CSn}}$.

Figure 11.18 shows an example in which sampling is executed in all subsequent cycles when $\overline{\text{DREQ}}$ cannot be detected.

- Burst Mode, Level Detection

In the case of burst mode with level detection, the $\overline{\text{DREQ}}$ sampling timing is the same as in cycle-steal mode.

For example, in figure 11.20, DMAC transfer begins, at the earliest, three cycles after the first sampling is performed. The second sampling is started two cycles after the first. Subsequent sampling operations are performed in the idle cycle following the end of the DMA transfer cycle.

In burst mode, also, the DACK output period is the same as in cycle-steal mode.

- Burst Mode, Edge Detection

In the case of burst mode with edge detection, $\overline{\text{DREQ}}$ sampling is only performed once.

For example, in figure 11.21, DMAC transfer begins, at the earliest, three cycles after the first sampling is performed. After this, DMAC transfer is executed continuously until the number of data transfers set in the DMATCR register have been completed. $\overline{\text{DREQ}}$ is not sampled during this time.

To restart DMAC after it has been suspended by an NMI, first clear NMIF, then input an edge request again.

In burst mode, also, the DACK output period is the same as in cycle-steal mode.

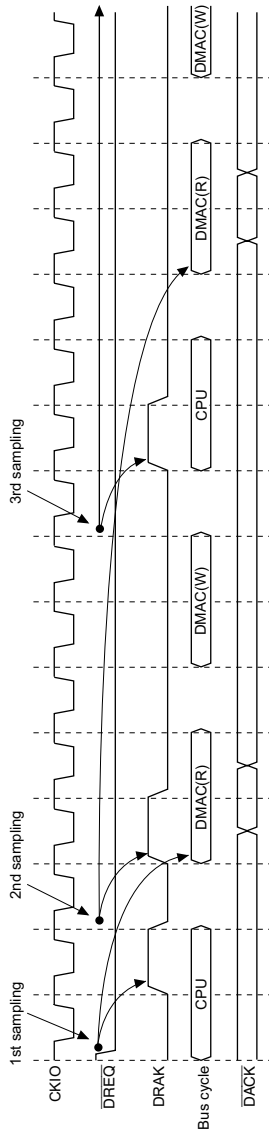

Figure 11.15 Cycle-Steal Mode, Level Input (CPU Access: 2 Cycles)

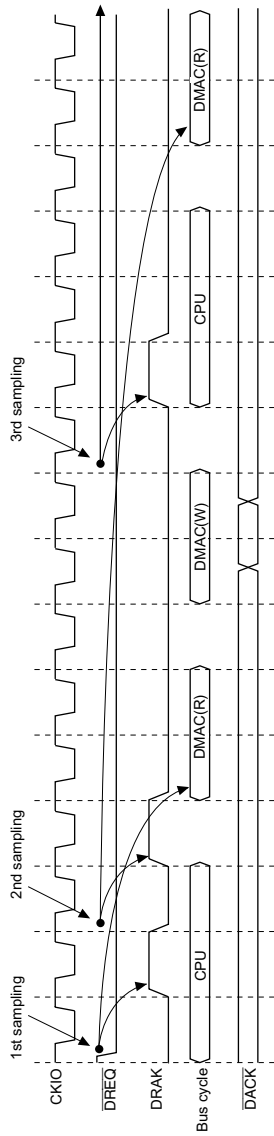

Figure 11.16 Cycle-Steal Mode, Level Input (CPU Access: 3 Cycles)

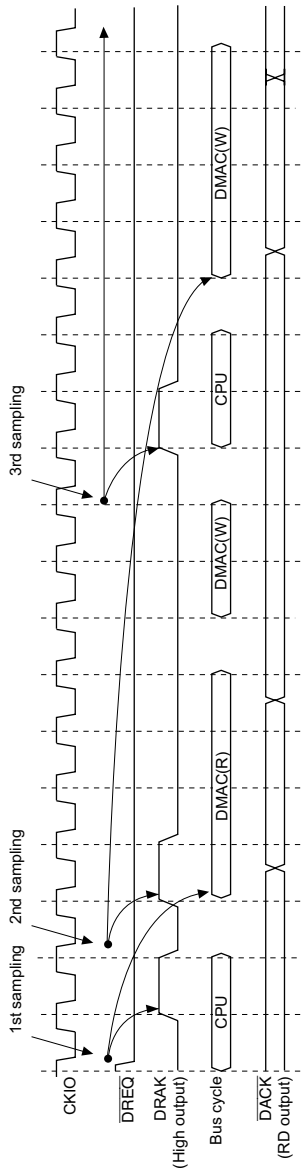

Figure 11.17 Cycle-Steal Mode, Level input (CPU Access: 2 Cycles, DMA RD Access: 4 Cycles)

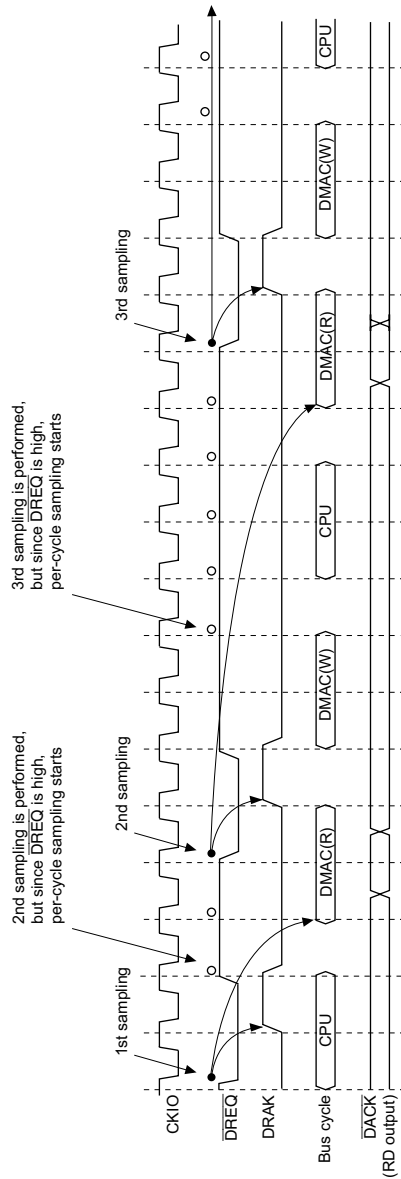

Figure 11.18 Cycle-Steal Mode, Level input (CPU Access: 2 Cycles, $\overline{\text{DREQ}}$ Input Delayed)

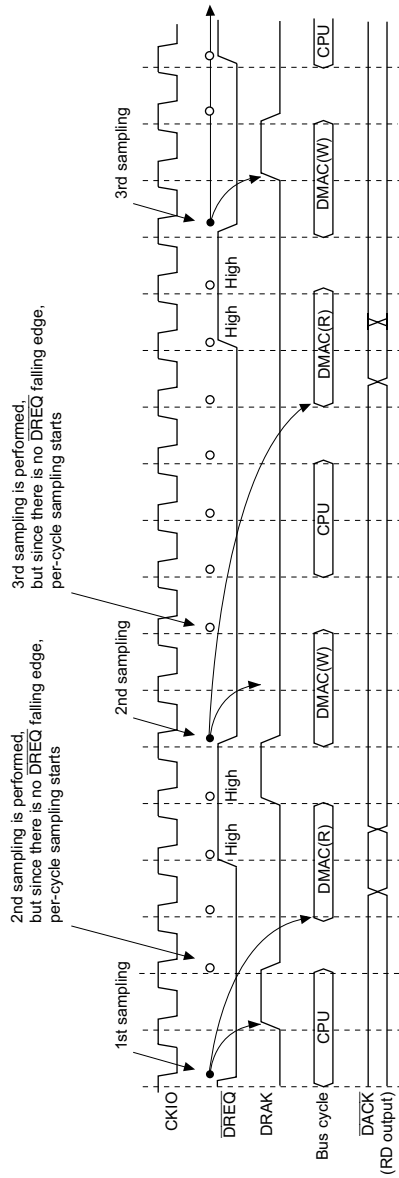

Figure 11.19 Cycle-Steal Mode, Edge input (CPU Access: 2 Cycles)

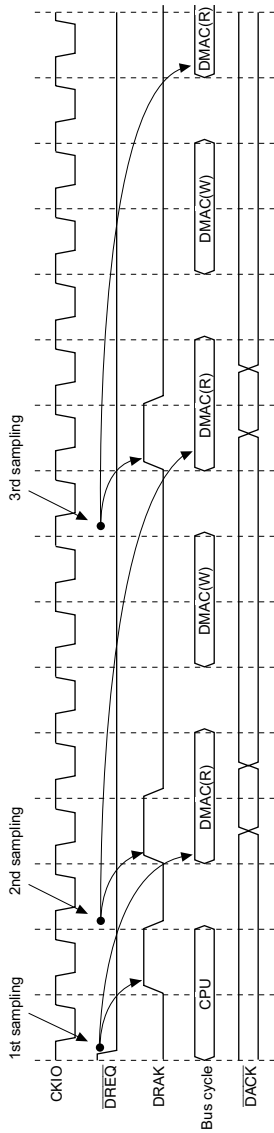

Figure 11.20 Burst Mode, Level Input

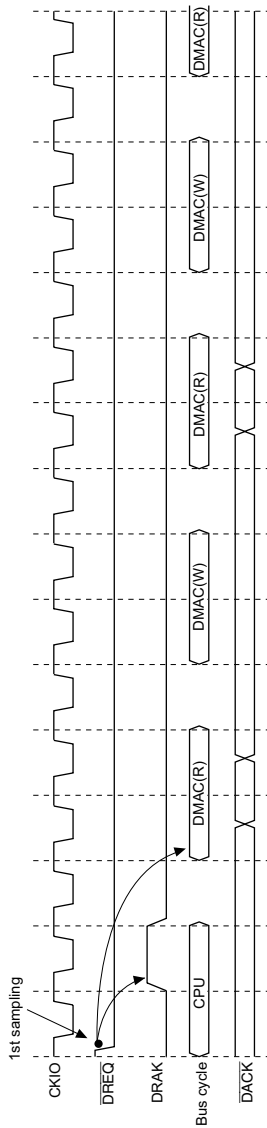

Figure 11.21 Burst Mode, Edge Input

11.3.6 Source Address Reload Function

Channel 2 includes a reload function, in which the value is returned to the value set in the source address register (SAR2) every four transfers by setting the RO bit in CHCR2 to 1. 16-byte transfer cannot be used. Figure 11.22 shows this operation. Figure 11.23 shows a timing chart for the source address reload function under the following conditions: burst mode, auto-request, 16-bit transfer data size, SAR2 incremented, DAR2 fixed, reload function on, and use of channel 2 only.

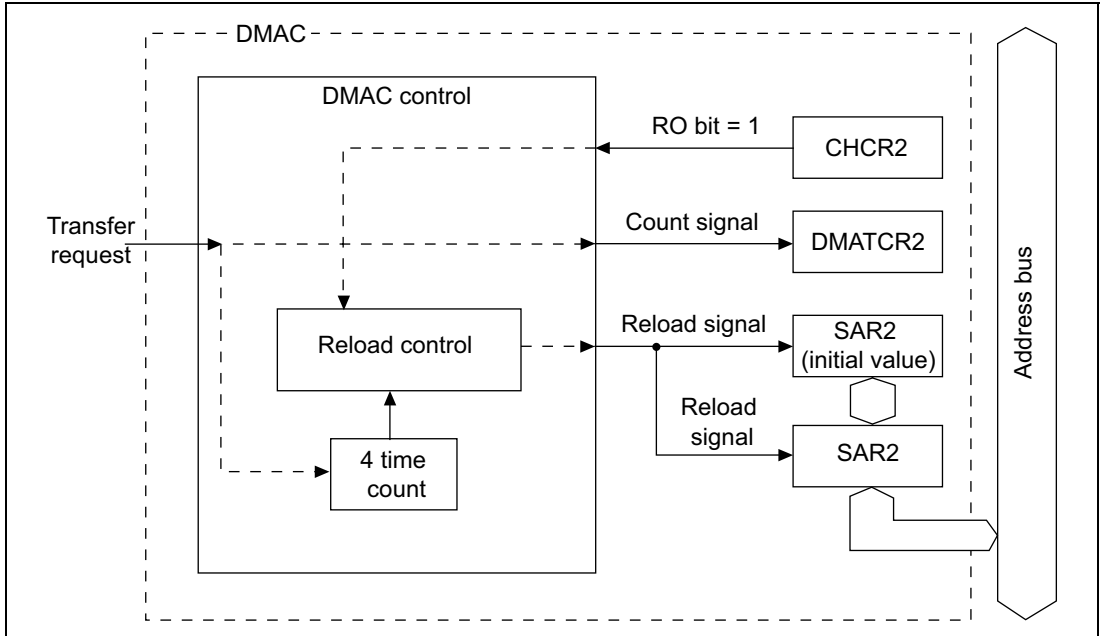

Figure 11.22 Source Address Reload Function Diagram

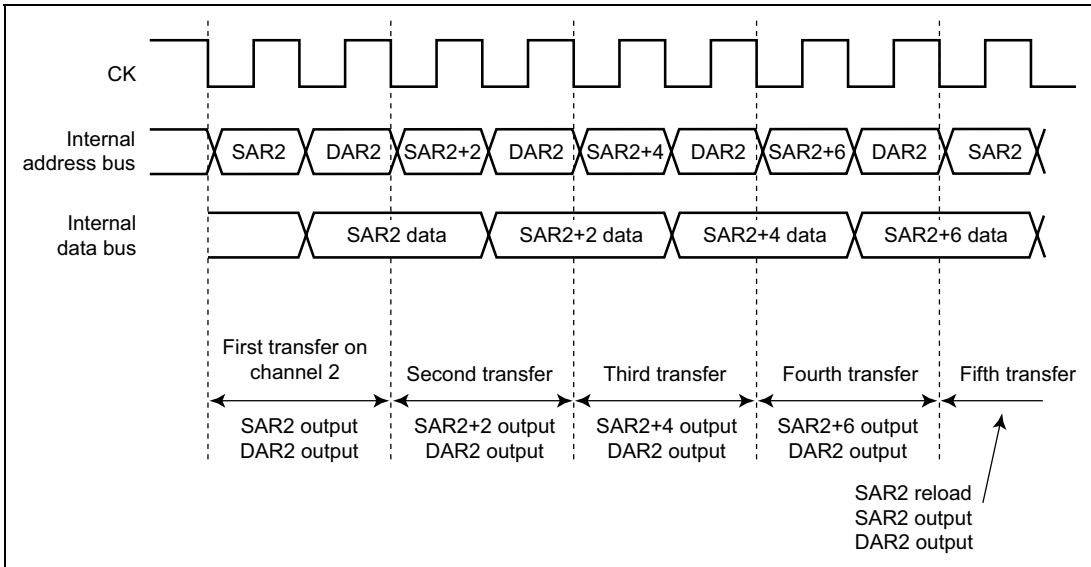

Figure 11.23 Timing Chart of Source Address Reload Function

The reload function can be executed with a transfer data size of 8, 16, or 32 bits.

DMATCR2, which specifies the transfer count, decrements 1 each time a transfer ends regardless of whether the reload function is on or off. Consequently, a multiple of four must be specified in DMATCR2 when the reload function is on. Operation is not guaranteed if other values are specified.

The counter that counts the execution of four transfers for the address reload function is reset by clearing the DME bit in DMAOR or the DE bit in CHCR2, by setting the transfer end flag (TE bit in CHCR2), by DMAC address error, and by NMI input, as well as by a reset, but the SAR2, DAR2, and DMATCR2 registers are not reset. Therefore, if these sources are generated, there will be a mix of an initialized counter and uninitialized registers in the DMAC, and a malfunction will be caused by restarting the DMAC in that state. Consequently, if one of these sources other than setting of the TE bit occurs during use of the address reload function, set SAR2, DAR2, and DMATCR2 again.

11.3.7 DMA Transfer Ending Conditions

The DMA transfer ending conditions are different for ending on an individual channel and ending on all channels together. At the end of transfer, the following conditions are applied except in the case where the value set in the DMA transfer count register (DMATCR) reaches 0.

(a) Cycle-steal mode (external request, internal request, and auto-request)

When the transfer ending conditions are satisfied, DMAC transfer request acceptance is suspended. The DMAC stops operating after completing the number of transfers that it has accepted until the ending conditions are satisfied.

In cycle-steal mode, the operation is the same regardless of whether the transfer request is detected by level or edge.

(b) Burst mode, edge detection (external request, internal request, and auto-request)

The timing from the point where the ending conditions are satisfied to the point where the DMAC stops operating is the same as in cycle-steal mode. With edge detection in burst mode, though only one transfer request is generated to start the DMAC, stop request sampling is performed at the same timing as transfer request sampling in cycle-steal mode. As a result, the period when a stop request is not sampled is regarded as the period when a transfer request is generated, and after performing the DMA transfer for this period, the DMAC stops operating.

(c) Burst mode, level detection (external request)

Same as in (a).

(d) Bus timing when transfer is suspended

Transfer is suspended when one transfer ends. Even if transfer ending conditions are satisfied during a read in direct address transfer in dual address mode, the subsequent write process is executed, and after the transfer in (a) to (c) above has been executed, DMAC operation is suspended.

Individual Channel Ending Conditions: There are two ending conditions. A transfer ends when the value of the channel's DMA transfer count register (DMATCR) is 0, or when the DE bit in the channel's CHCR register is cleared to 0.

- When DMATCR is 0: When the DMATCR value becomes 0 and the corresponding channel's DMA transfer ends, the transfer end flag bit (TE) is set in CHCR. If the IE (interrupt enable) bit has been set, a DMAC interrupt (DEI) request is sent to the CPU. This transfer ending does not apply to (a) to (d) described above.
- When DE in CHCR is 0: Software can halt a DMA transfer by clearing the DE bit in the channel's CHCR register. The TE bit is not set when this happens. This transfer ending applies to (a) to (d) described above.

Conditions for Ending on All Channels Simultaneously: Transfers on all channels end (1) when the AE or NMIF (NMI flag) bit is set to 1 in DMAOR, or (2) when the DME bit in DMAOR is cleared to 0.

- Transfer ending when the NMIF bit is set to 1 in DMAOR: When an NMI interrupt occurs, the AE or NMIF bit is set to 1 in DMAOR and all channels stop their transfers according to the conditions in (a) to (d) described above, and pass the bus to an other bus master. Consequently, even if the AE or NMI bit is set to 1 during transfer, SAR, DAR, DMATCR are updated. The TE bit is not set. To resume transfer after NMI interrupt exception handling, clear the NMIF bit to 0. At this time, if there are channels that should not be restarted, clear the corresponding DE bit in CHCR.
- Transfer ending when DME is cleared to 0 in DMAOR: Clearing the DME bit to 0 in DMAOR forcibly aborts transfer on all channels. The TE bit is not set. All channels abort their transfer according to the conditions in (a) to (d) in section 11.3.7, DMA Transfer Ending Conditions, as in NMI interrupt generation. In this case, the values in SAR, DAR, and DMATCR are also updated.

11.4 Compare Match Timer (CMT)

11.4.1 Overview

The DMAC has an on-chip compare match timer (CMT) to generate DMA transfer requests. The CMT has a 16-bit counter.

Features

The CMT has the following features:

- Four types of counter input clock can be selected
 - One of four internal clocks ($P\phi/4$, $P\phi/8$, $P\phi/16$, $P\phi/64$) can be selected.
- Generates a DMA transfer request when compare match occurs.

Block Diagram

Figure 11.24 shows a block diagram of the CMT.

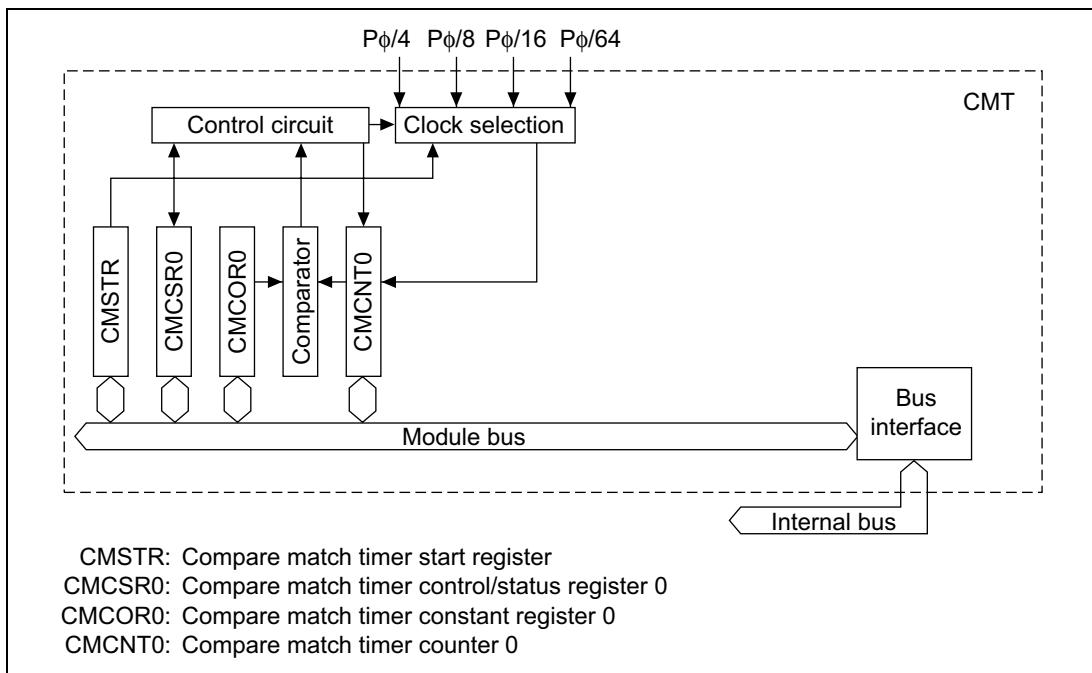

Figure 11.24 Block Diagram of CMT

Register Configuration

Table 11.7 summarizes the CMT register configuration.

Table 11.7 Register Configuration

Name	Abbreviation	R/W	Initial Value	Address	Access Size (Bits)
Compare match timer start register	CMSTR	R/(W)	H'0000	H'04000070 (H'A4000070)*2	8, 16, 32
Compare match timer control/status register 0	CMCSR0	R/(W)*1	H'0000	H'04000072 (H'A4000072)*2	8, 16, 32
Compare match counter 0	CMCNT0	R/W	H'0000	H'04000074 (H'A4000074)*2	8, 16, 32
Compare match constant register 0	CMCOR0	R/W	H'FFFF	H'04000076 (H'A4000076)*2	8, 16, 32

Notes: 1. The only value that can be written to the CMF bit in CMCSR0 is 0 to clear the flag.
 2. When address translation by the MMU does not apply, the address in parentheses should be used.

11.4.2 Register Descriptions

Compare Match Timer Start Register (CMSTR)

The compare match timer start register (CMSTR) is a 16-bit register that selects whether compare match counter 0 (CMCNT0) is operated or halted. It is initialized to H'0000 by a reset, but retains its previous value in standby mode.

Bit:	15	14	13	12	11	10	9	8
	—	—	—	—	—	—	—	—
Initial value:	0	0	0	0	0	0	0	0
R/W:	R	R	R	R	R	R	R	R
Bit:	7	6	5	4	3	2	1	0
	—	—	—	—	—	—	—	STR0
Initial value:	0	0	0	0	0	0	0	0
R/W:	R	R	R	R	R	R	R/W	R/W

Bits 15 to 2—Reserved: These bits are always read as 0. The write value should always be 0.

Bit 1—Reserved: This bit can be read or written. The write value should always be 0.

Bit 0—Count Start 0 (STR0): Selects whether to operate or halt CMCNT0.

Bit 0: STR0	Description
0	CMCNT0 count operation halted (Initial value)
1	CMCNT0 count operation

Compare Match Timer Control/Status Register 0 (CMCSR0)

The compare match timer control/status register 0 (CMCSR0) is a 16-bit register that indicates the occurrence of compare matches, sets the enable/disable status of interrupts, and establishes the clock used for incrementation. It is initialized to H'0000 by a reset, but retains its previous value in standby mode.

Bit:	15	14	13	12	11	10	9	8
	—	—	—	—	—	—	—	—
Initial value:	0	0	0	0	0	0	0	0
R/W:	R	R	R	R	R	R	R	R
Bit:	7	6	5	4	3	2	1	0
	CMF	—	—	—	—	—	CKS1	CKS0
Initial value:	0	0	0	0	0	0	0	0
R/W:	R/(W)*	R/W	R	R	R	R	R/W	R/W

Note: * The only value that can be written is 0 to clear the flag.

Bits 15 to 8 and 5 to 2—Reserved: These bits are always read as 0. The write value should always be 0.

Bit 7—Compare Match Flag (CMF): Indicates whether or not the compare match timer counter 0 (CMCNT0) and compare match timer constant 0 (CMCOR0) values match.

Bit 7: CMF	Description
0	CMCNT0 and CMCOR0 values do not match (Initial value) Clearing condition: Write 0 to CMF after reading CMF = 1
1	CMCNT0 and CMCOR0 values match

Bit 6—Reserved: This bit can be read or written. The write value should always be 0.

Bits 1 and 0—Clock Select 1 and 0 (CKS1, CKS0): Select the clock input to CMCNT from among the four internal clocks obtained by dividing the system clock (P ϕ). When the STR bit in CMSTR is set to 1, CMCNT0 begins incrementing on the clock selected by CKS1 and CKS0.

Bit 1: CKS1	Bit 0: CKS0	Description
0	0	P ϕ /4 (Initial value)
	1	P ϕ /8
1	0	P ϕ /16
	1	P ϕ /64

Compare Match Counter 0 (CMCNT0)

Compare match counter 0 (CMCNT0) is a 16-bit register used as an up-counter.

When an internal clock is selected with the CKS1 and CKS0 bits in the CMCSR0 register and the STR bit in CMSTR is set to 1, CMCNT0 begins incrementing on that clock. When the CMCNT0 value matches that of compare match constant register 0 (CMCOR0), CMCNT0 is cleared to H'0000 and the CMF flag in CMCSR0 is set to 1.

CMCNT0 is initialized to H'0000 by a reset, but retains its previous value in standby mode.

Bit:	15	14	13	12	11	10	9	8
	<input type="text"/>	<input type="text"/>	<input type="text"/>	<input type="text"/>	<input type="text"/>	<input type="text"/>	<input type="text"/>	<input type="text"/>
Initial value:	0	0	0	0	0	0	0	0
R/W:	R/W	R/W	R/W	R/W	R/W	R/W	R/W	R/W
Bit:	7	6	5	4	3	2	1	0
	<input type="text"/>	<input type="text"/>	<input type="text"/>	<input type="text"/>	<input type="text"/>	<input type="text"/>	<input type="text"/>	<input type="text"/>
Initial value:	0	0	0	0	0	0	0	0
R/W:	R/W	R/W	R/W	R/W	R/W	R/W	R/W	R/W

Compare Match Constant Register 0 (CMCOR0)

Compare match constant register 0 (CMCOR0) is a 16-bit register that sets the CMCNT0 compare match period.

CMCOR0 is initialized to H'FFFF by a reset, but retains its previous value in standby mode.

Bit:	15	14	13	12	11	10	9	8
Initial value:	1	1	1	1	1	1	1	1
R/W:	R/W	R/W	R/W	R/W	R/W	R/W	R/W	R/W
Bit:	7	6	5	4	3	2	1	0
Initial value:	1	1	1	1	1	1	1	1
R/W:	R/W	R/W	R/W	R/W	R/W	R/W	R/W	R/W

11.4.3 Operation

Period Count Operation

When an internal clock is selected with the CKS1 and CKS0 bits in the CMCSR0 register and the STR bit in CMSTR is set to 1, CMCNT0 begins incrementing on the selected clock. When the CMCNT counter value matches that of CMCOR0, the CMCNT0 counter is cleared to H'0000 and the CMF flag in the CMCSR0 register is set to 1. The CMCNT0 counter begins counting up again from H'0000.

Figure 11.25 shows the compare match counter operation.

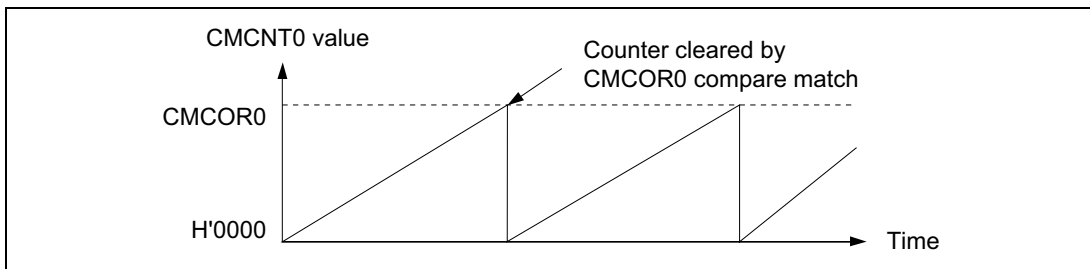

Figure 11.25 Counter Operation

CMCNT0 Count Timing

One of four clocks ($P\phi/4$, $P\phi/8$, $P\phi/16$, $P\phi/64$) obtained by dividing the $P\phi$ clock can be selected with the CKS1 and CKS0 bits in CMCSR0. Figure 11.26 shows the timing.

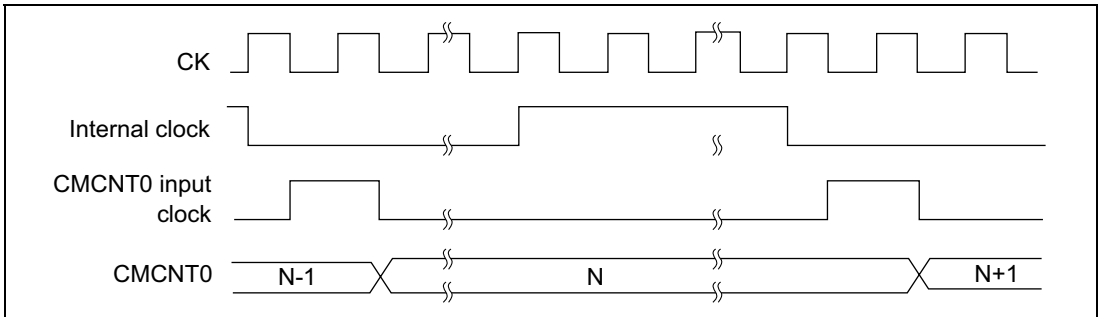

Figure 11.26 Count Timing

11.4.4 Compare Match

Compare Match Flag Setting Timing

The CMF bit in the CMCSR0 register is set to 1 by the compare match signal generated when the CMCOR0 register and the CMCNT0 counter match. The compare match signal is generated in the final state of the match (timing at which the CMCNT0 counter matching count value is updated). Consequently, after the CMCOR0 register and the CMCNT0 counter match, a compare match signal will not be generated until a CMCNT0 counter input clock occurs. Figure 11.27 shows the CMF bit setting timing.

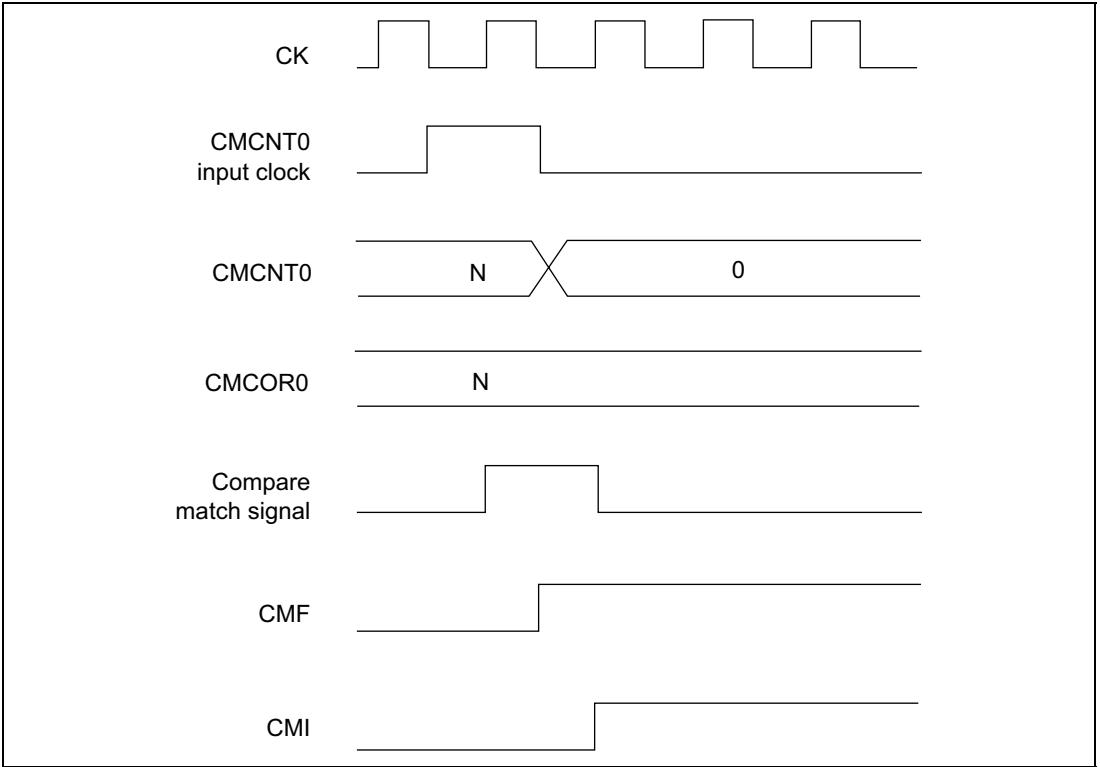

Figure 11.27 CMF Setting Timing

Compare Match Flag Clearing Timing

The CMF bit in the CMCSR0 register is cleared by writing 0 to it after reading 1. Figure 11.28 shows the timing when the CMF bit is cleared by the CPU.

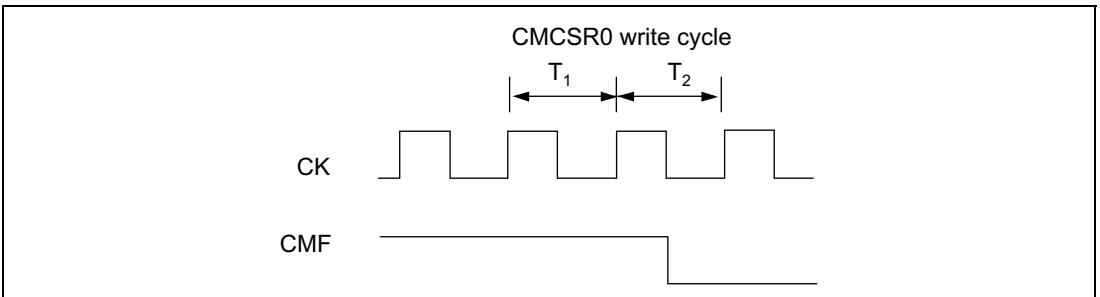

Figure 11.28 Timing of CMF Clearing by the CPU

11.5 Examples of Use

11.5.1 Example of DMA Transfer between On-Chip IrDA and External Memory

In this example, receive data of the on-chip IrDA is transferred to external memory using DMAC channel 3. Table 11.8 shows the transfer conditions and register settings. In addition, it is recommended that the trigger for the number of receive FIFO data bytes in IrDA be set to 1 (RTRG1 = RTRG0 = 0 in SCFCR).

Table 11.8 Transfer Conditions and Register Settings for Transfer between On-Chip SCI and External Memory

Transfer Conditions	Register	Setting
Transfer source: RDR1 of on-chip IrDA	SAR3	H'0400014A
Transfer destination: External memory	DAR3	H'00400000
Number of transfers: 64	DMATCR3	H'00000040
Transfer source address: Fixed	CHCR3	H'00004B05
Transfer destination address: Incremented		
Transfer request source: IrDA (RXI1)		
Bus mode: Cycle-steal		
Transfer unit: Byte		
Interrupt request generated at end of transfer		
Channel priority order: 0 > 2 > 3 > 1	DMAOR	H'0101

11.5.2 Example of DMA Transfer between A/D Converter and External Memory

In this example, DMA transfer is performed between the on-chip A/D converter (transfer source) and the external memory (transfer destination) with the address reload function on. Table 11.9 shows the transfer conditions and register settings.

Table 11.9 Transfer Conditions and Register Settings for Transfer between On-Chip A/D Converter and External Memory

Transfer Conditions	Register	Setting
Transfer source: On-chip A/D converter	SAR2	H'04000080
Transfer destination: Internal memory	DAR2	H'00400000
Number of transfers: 128 (reloading 32 times)	DMATCR2	H'00000080
Transfer source address: Incremented	CHCR2	H'00089E35
Transfer destination address: Decrementd		
Transfer request source: A/D converter		
Bus mode: Burst		
Transfer unit: Longword		
Interrupt request generated at end of transfer		
Channel priority order: 0 > 2 > 3 > 1	DMAOR	H'0101

When the address reload function is on, the value set in SAR returns to the initially set value every four transfers. In this example, when a transfer request is generated from the A/D converter, byte data is read from the register at address H'04000080 in the A/D converter, and is written to external memory address H'00400000. Since longword data has been transferred, the values in SAR and DAR are H'04000084 and H'003FFFFC, respectively. The bus is kept and data transfers are performed successively because this transfer is in burst mode.

After four transfers end, fifth and sixth transfers are performed if the address reload function is off, and the value in SAR is incremented from H'0400008C to H'04000090, H'04000094... If the address reload function is on, DMA transfer stops after the fourth transfer ends, and the bus request signal to the CPU is cleared. At this time, the value stored in SAR is not incremented from H'0400008C to H'04000090, but returns to the initially set value, H'04000080. The value in DAR continues to be decremented regardless of whether the address reload function is on or off.

As a result, the values in the DMAC are as shown in table 11.10 when the fourth transfer ends, depending on whether the address reload function is on or off.

Table 11.10 Values in DMAC after End of Fourth Transfer

Items	Address reload on	Address reload off
SAR	H'04000080	H'04000090
DAR	H'003FFFFC	H'003FFFFC
DMATCR	H'0000007C	H'0000007C
Bus right	Released	Held
DMAC operation	Stops	Keeps operating
Interrupt	Not generated	Not generated
Transfer request source flag clearing	Executed	Not executed

- Notes:
1. An interrupt is generated regardless of whether the address reload function is on or off, if transfers are executed until the value in DMATCR reaches 0 and the IE bit in CHCR has been set to 1.
 2. The transfer request source flag is cleared regardless of whether the address reload function is on or off, if transfers are executed until the value in DMATCR reaches 0.
 3. Specify burst mode when using the address reload function. This function may not be correctly executed in cycle-steal mode.
 4. Set a multiple of four in DMATCR when using the address reload function. This function may not be correctly executed if other values are specified.

11.5.3 Example of DMA Transfer between External Memory and SCIF Transmitter (Indirect Address On)

In this example, DMA transfer is performed between the external memory specified by indirect address (transfer source) and the SCIF transmitter (transfer destination) using DMAC channel 3. Table 11.11 shows the transfer conditions and register settings. In addition, the trigger for the number of transmit FIFO data bytes is set to 1 (TTRG1 = TTRG0 = 1 in SCFCR).

Table 11.11 Transfer Conditions and Register Settings for Transfer between External Memory and SCIF Transmitter

Transfer Conditions	Register	Setting
Transfer source: External memory	SAR3	H'00400000
Value stored in address H'00400000	—	H'00450000
Value stored in address H'04500000	—	H'55
Transfer destination: On-chip SCIF TDR2	DAR3	H'04000156
Number of transfers: 10	DMATCR3	H'0000000A
Transfer source address: Incremented	CHCR3	H'00011C01
Transfer destination address: Fixed		
Transfer request source: SCIF (TXI2)		
Bus mode: Cycle-steal		
Transfer unit: Byte		
No interrupt request generated at end of transfer		
Channel priority order: 0 > 1 > 2 > 3	DMAOR	H'0001

If the indirect address is on, data stored in the address set in SAR is not used as transfer source data. In the indirect address, after the value stored in the address set in SAR is read, that read value is used as an address again, and the value stored in that address is read and stored in the address set in DAR.

In the example shown in table 11.11, when an SCIF transfer request is generated, the DMAC reads the value in address H'00400000 set in SAR3. Since the value H'00450000 is stored in that address, the DMAC reads the value H'00450000. Next, the DMAC uses that read value as an address again, and reads the value H'55 stored in that address. Then, the DMAC writes the value H'55 to address H'04000156 set in DAR3; this completes one indirect address transfer.

In the indirect address, when data is read first from the address set in SAR3, the data transfer size is always longword regardless of the settings of the TS0 and TS1 bits that specify the transfer data size. However, whether the transfer source address is fixed, incremented, or decremented is specified by the SM0 and SM1 bits. Therefore, in this example, though the transfer data size is specified as byte, the value in SAR3 is H'00400004 when one transfer ends. Write operations are the same as in normal dual address transfer.

11.6 Usage Notes

1. The DMA channel control registers (CHCR0–CHCR3) can be accessed with any data size. The DMA operation register (DMAOR) must be accessed by byte (8 bits) or word (16 bits); other registers must be accessed by word (16 bits) or longword (32 bits).
2. Before rewriting the RS0–RS3 bits in CHCR0–CHCR3, first clear the DE bit to 0 (when rewriting CHCR with a byte address, be sure to set the DE bit to 0 in advance).
3. Even if an NMI interrupt is input when the DMAC is not operating, the NMIF bit in DMAOR will be set.
4. Before entering standby mode, the DME bit in DMAOR must be cleared to 0 and the transfers accepted by the DMAC completed.
5. The on-chip peripherals which the DMAC can access are the IrDA, SCIF, A/D converter, D/A converter, and I/O ports. Do not access other peripherals with the DMAC.
6. When starting up the DMAC, set CHCR or DMAOR last. Normal operation is not guaranteed if settings for another register are made last.
7. Even if the maximum number of transfers are performed in the same channel after the DMATCR count reaches 0 and DMA transfer ends normally, write 0 to DMATCR. Otherwise, normal DMA transfer may not be performed.
8. When using the address reload function, specify burst mode as the transfer mode. In cycle-steal mode, normal DMA transfer may not be performed.
9. When using the address reload function, set a multiple of four in DMATCR. Normal operation is not guaranteed if other values are specified.
10. When detecting an external request at the falling edge, keep the external request pin high when setting the DMAC.
11. Do not access the space from H'4000062 to H'400006F, which is not used in the DMAC. Accessing this space may cause malfunctions.
12. The $\overline{\text{WAIT}}$ signal is ignored in the case of a write to external address space in dual address mode with 16-byte transfer, or transfer from an external device with DACK to external address space in signal address mode with 16-byte transfer.
13. DMAC transfers should not be performed in the sleep mode under conditions other than when the clock ratio of I ϕ (on-chip clock) to B ϕ (bus clock) is 1:1.
14. When the following three conditions are all met, the frequency control register (FRQCR) should not be changed while a DMAC transfer is in progress.
 - Bits IFC2 to IFC0 are changed.
 - STC2 to STC0 in FRQCR are not changed.
 - The clock ratio of I ϕ (on-chip clock) to B ϕ (bus clock) after the change is other than 1:1.

Section 12 Timer (TMU)

12.1 Overview

The SH7709S has a three-channel (channels 0 to 2) 32-bit timer unit (TMU).

12.1.1 Features

The TMU has the following features:

- Each channel is provided with an auto-reload 32-bit down counter.
- Channel 2 is provided with an input capture function.
- All channels are provided with 32-bit constant registers and 32-bit down counters that can be read or written to at any time.
- All channels generate interrupt requests when the 32-bit down counter underflows (H'00000000 → H'FFFFFFFF).
- Allows selection between 6 counter input clocks: External clock (TCLK), on-chip RTC output clock (16 kHz), P ϕ /4, P ϕ /16, P ϕ /64, P ϕ /256. (P ϕ is the internal clock for peripheral modules.) See section 9, On-Chip Oscillation Circuits, for more information on the clock pulse generator.
- All channels can operate when the SH7709S is in standby mode: When the RTC output clock is being used as the counter input clock, the SH7709S is still able to count in standby mode.
- Synchronized read: TCNT is a sequentially changing 32-bit register. Since the peripheral module used has an internal bus width of 16 bits, a time lag can occur between the time when the upper 16 bits and lower 16 bits are read. To correct the discrepancy in the counter read value caused by this time lag, a synchronization circuit is built into the TCNT so that the entire 32-bit data in the TCNT can be read at once.
- The maximum operating frequency of the 32-bit counter is 2 MHz on all channels: Operate the SH7709S so that the clock input to the timer counters of each channel (obtained by dividing the external clock and internal clock with the prescaler) does not exceed the maximum operating frequency.

12.1.2 Block Diagram

Figure 12.1 shows a block diagram of the TMU.

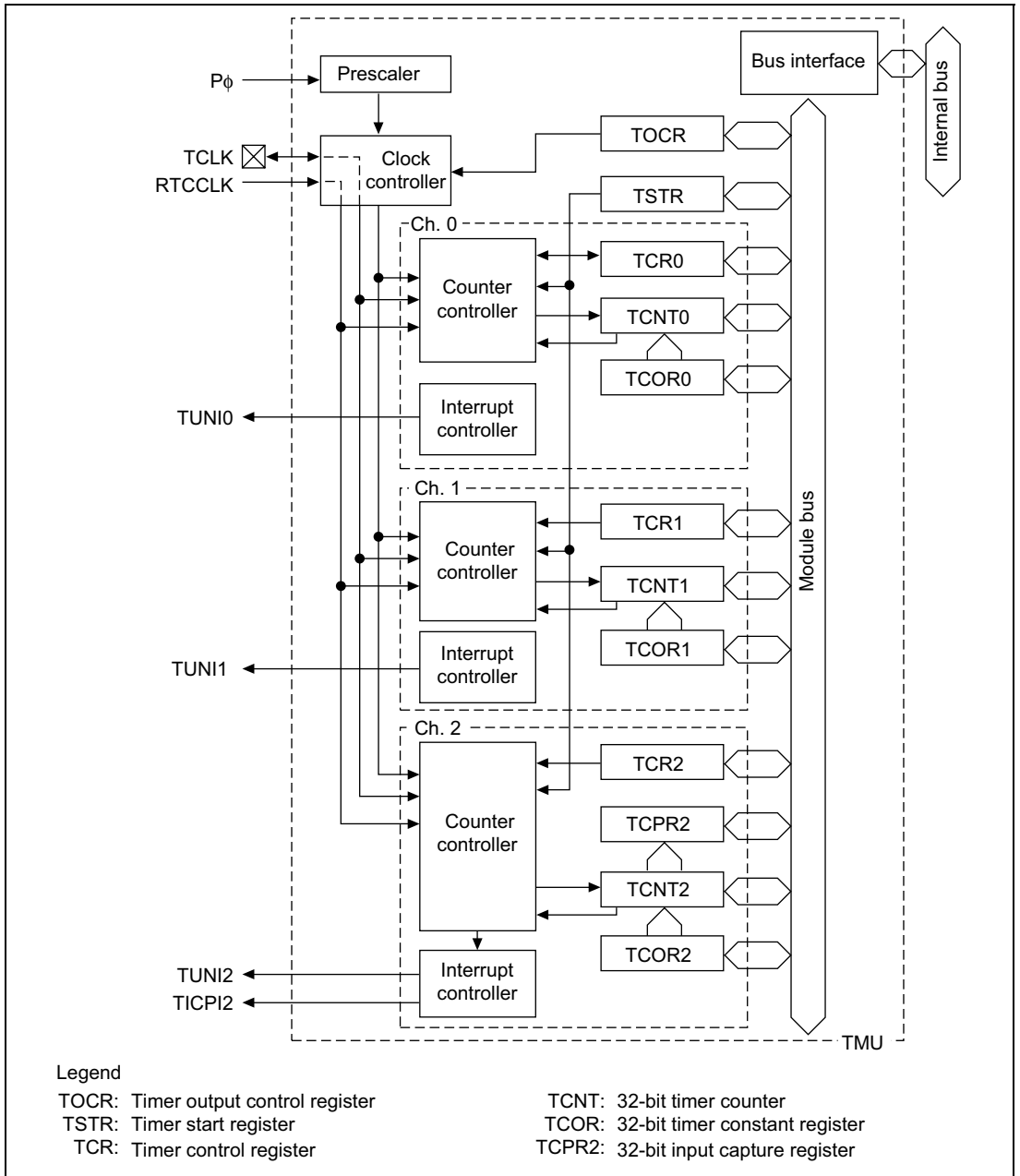

Figure 12.1 Block Diagram of TMU

12.1.3 Pin Configuration

Table 12.1 shows the pin configuration of the TMU.

Table 12.1 TMU Pin

Channel	Pin	I/O	Description
Clock input/clock output	TCLK	I/O	External clock input pin/input capture control input pin/realtime clock (RTC) output pin

12.1.4 Register Configuration

Table 12.2 shows the TMU register configuration.

Table 12.2 TMU Registers

Channel	Register	Abbreviation	R/W	Initial Value*	Address	Access Size
Common	Timer output control register	TOCR	R/W	H'00	H'FFFFFFE90	8
	Timer start register	TSTR	R/W	H'00	H'FFFFFFE92	8
0	Timer constant register 0	TCOR0	R/W	H'FFFFFFFF	H'FFFFFFE94	32
	Timer counter 0	TCNT0	R/W	H'FFFFFFFF	H'FFFFFFE98	32
	Timer control register 0	TCR0	R/W	H'0000	H'FFFFFFE9C	16
1	Timer constant register 1	TCOR1	R/W	H'FFFFFFFF	H'FFFFFFEA0	32
	Timer counter 1	TCNT1	R/W	H'FFFFFFFF	H'FFFFFFEA4	32
	Timer control register 1	TCR1	R/W	H'0000	H'FFFFFFEA8	16
2	Timer constant register 2	TCOR2	R/W	H'FFFFFFFF	H'FFFFFFEAC	32
	Timer counter 2	TCNT2	R/W	H'FFFFFFFF	H'FFFFFFEB0	32
	Timer control register 2	TCR2	R/W	H'0000	H'FFFFFFEB4	16
	Input capture register 2	TCPR2	R	Undefined	H'FFFFFFEB8	32

Note: * Initialized by power-on resets or manual resets.

12.2 TMU Registers

12.2.1 Timer Output Control Register (TOCR)

TOCR is an 8-bit readable/writable register that selects whether to use the external TCLK pin as an external clock or an input capture control usage input pin, or an output pin for the on-chip RTC output clock. TOCR is initialized to H'00 by a power-on reset or manual reset, but is not initialized in standby mode.

Bit:	7	6	5	4	3	2	1	0
	—	—	—	—	—	—	—	TCOE
Initial value:	0	0	0	0	0	0	0	0
R/W:	R	R	R	R	R	R	R	R/W

Bits 7 to 1—Reserved: These bits are always read as 0. The write value should always be 0.

Bit 0—Timer Clock Pin Control (TCOE): Selects use of the timer clock pin (TCLK) as an external clock output pin or input pin for input capture control for the on-chip timer, or as an output pin for the on-chip RTC output clock. Since the TCLK pin is multiplexed as the PTH7 pin, when the pin is used as TCLK, bits PH7MD1 and PH7MD0 in the PHCR register should be set to 00 (the "other function" setting).

Bit 0: TCOE	Description
0	Timer clock pin (TCLK) used as external clock input or input capture control input pin for the on-chip timer (Initial value)
1	Timer clock pin (TCLK) used as output pin for on-chip RTC output clock

12.2.2 Timer Start Register (TSTR)

TSTR is an 8-bit readable/writable register that selects whether to run or halt the timer counters (TCNT) for channels 0–2. TSTR is initialized to H'00 by a power-on reset or manual reset, but is not initialized in standby mode when the input clock selected for the channel is the on-chip RTC clock (RTCCLK). Only when an external clock (TCLK) or the peripheral clock (P ϕ) is used as the input clock, it is initialized in standby mode when the multiplication ratio of PLL circuit 1 is changed or when the MSTP2 bit in STBCR is set to 1.

Bit:	7	6	5	4	3	2	1	0
	—	—	—	—	—	STR2	STR1	STR0
Initial value:	0	0	0	0	0	0	0	0
R/W:	R	R	R	R	R	R/W	R/W	R/W

Bits 7 to 3—Reserved: These bits are always read as 0. The write value should always be 0.

Bit 2—Counter Start 2 (STR2): Selects whether to run or halt timer counter 2 (TCNT2).

Bit 2: STR2	Description
0	TCNT2 count halted (Initial value)
1	TCNT2 counts

Bit 1—Counter Start 1 (STR1): Selects whether to run or halt timer counter 1 (TCNT1).

Bit 1: STR1	Description
0	TCNT1 count halted (Initial value)
1	TCNT1 counts

Bit 0—Counter Start 0 (STR0): Selects whether to run or halt timer counter 0 (TCNT0).

Bit 0: STR0	Description
0	TCNT0 count halted (Initial value)
1	TCNT0 counts

12.2.3 Timer Control Registers (TCR)

The timer control registers (TCR) control the timer counters (TCNT) and interrupts. The TMU has three TCR registers, one for each channel.

The TCR registers are 16-bit readable/writable registers that control the issuance of interrupts when the flag indicating timer counter (TCNT) underflow has been set to 1, and also carry out counter clock selection. When the external clock has been selected, they also select its edge. Additionally, TCR2 controls the channel 2 input capture function and the issuance of interrupts during input capture. The TCR registers are initialized to H'0000 by a power-on reset and manual reset, but are not initialized in standby mode and retain their contents.

Channels 0 and 1 TCR Bit Configuration:

Bit:	15	14	13	12	11	10	9	8
	—	—	—	—	—	—	—	UNF
Initial value:	0	0	0	0	0	0	0	0
R/W:	R	R	R	R	R	R	R	R/W
Bit:	7	6	5	4	3	2	1	0
	—	—	UNIE	CKEG1	CKEG0	TPSC2	TPSC1	TPSC0
Initial value:	0	0	0	0	0	0	0	0
R/W:	R	R	R/W	R/W	R/W	R/W	R/W	R/W

Channel 2 TCR Bit Configuration:

Bit:	15	14	13	12	11	10	9	8
	—	—	—	—	—	—	ICPF	UNF
Initial value:	0	0	0	0	0	0	0	0
R/W:	R	R	R	R	R	R	R/W	R/W
Bit:	7	6	5	4	3	2	1	0
	ICPE1	ICPE0	UNIE	CKEG1	CKEG0	TPSC2	TPSC1	TPSC0
Initial value:	0	0	0	0	0	0	0	0
R/W:	R/W	R/W	R/W	R/W	R/W	R/W	R/W	R/W

Bits 15 to 10, 9 (except TCR2), 7, and 6 (except TCR2)—Reserved: These bits are always read as 0. The write value should always be 0.

Bit 9—Input Capture Interrupt Flag (ICPF): A function of channel 2 only: the flag is set when input capture is requested via the TCLK pin.

Bit 9: ICPF	Description
0	No input capture request has been issued Clearing condition: When 0 is written to ICPF (Initial value)
1	Input capture has been requested via the TCLK pin Setting condition: When input capture is requested via the TCLK pin*

Note: * Contents do not change when 1 is written to ICPF.

Bit 8—Underflow Flag (UNF): Status flag that indicates occurrence of a TCNT underflow.

Bit 8: UNF	Description
0	TCNT has not underflowed Clearing condition: When 0 is written to UNF (Initial value)
1	TCNT has underflowed Setting condition: When TCNT underflows*

Note: * Contents do not change when 1 is written to UNF.

Bits 7 and 6—Input Capture Control (ICPE1, ICPE0): A function of channel 2 only: determines whether the input capture function can be used, and when used, whether or not to enable interrupts.

When using this input capture function it is necessary to set the TCLK pin to input mode with the TCOE bit in the TOCR register. Additionally, use the CKEG bit to designate use of either the rising or falling edge of the TCLK pin to set the value in TCNT2 in the input capture register (TCPR2).

Bit 7: ICPE1	Bit 6: ICPE0	Description
0	0	Input capture function is not used (Initial value)
	1	Reserved (Setting prohibited)
1	0	Input capture function is used. Interrupt due to ICPF (TICPI2) is not enabled
	1	Input capture function is used. Interrupt due to ICPF (TICPI2) is enabled

Bit 5—Underflow Interrupt Control (UNIE): Controls enabling of interrupt generation when the status flag (UNF) indicating TCNT underflow has been set to 1.

Bit 5: UNIE	Description
0	Interrupt due to UNF (TUNI) is not enabled (Initial value)
1	Interrupt due to UNF (TUNI) is enabled

Bits 4 and 3—Clock Edge 1 and 0 (CKEG1, CKEG0): Select the external clock edge when the external clock is selected, or when the input capture function is used.

Bit 4: CKEG1	Bit 3: CKEG0	Description
0	0	Count/capture register set on rising edge (Initial value)
	1	Count/capture register set on falling edge
1	X	Count/capture register set on both rising and falling edge

Note: X means 0, 1, or 'Don't care'.

Bits 2 to 0—Timer Prescaler 2 to 0 (TPSC2 to TPSC0): Select the TCNT count clock.

Bit 2: TPSC2	Bit 1: TPSC1	Bit 0: TPSC0	Description
0	0	0	Internal clock: count on P ϕ /4 (Initial value)
		1	Internal clock: count on P ϕ /16
	1	0	Internal clock: count on P ϕ /64
		1	Internal clock: count on P ϕ /256
1	0	0	Internal clock: count on clock output of on-chip RTC (RTC CLK)
		1	Count on TCLK pin input
	1	0	Reserved (Setting prohibited)
		1	Reserved (Setting prohibited)

12.2.4 Timer Constant Registers (TCOR)

The TMU has three TCOR registers, one for each channel. TCOR specifies the value for setting in TCNT when a TCNT count-down results in an under flow.

TCOR is a 32-bit readable/writable register. TCOR is initialized to H'FFFFFFFF by a power-on reset or manual reset, but is not initialized, and retains its contents, in standby mode.

Bit:	31	30	29	28	27	26	25	24
	<input type="checkbox"/>	<input type="checkbox"/>	<input type="checkbox"/>	<input type="checkbox"/>	<input type="checkbox"/>	<input type="checkbox"/>	<input type="checkbox"/>	<input type="checkbox"/>
Initial value:	1	1	1	1	1	1	1	1
R/W:	R/W	R/W	R/W	R/W	R/W	R/W	R/W	R/W
Bit:	23	22	21	20	19	18	17	16
	<input type="checkbox"/>	<input type="checkbox"/>	<input type="checkbox"/>	<input type="checkbox"/>	<input type="checkbox"/>	<input type="checkbox"/>	<input type="checkbox"/>	<input type="checkbox"/>
Initial value:	1	1	1	1	1	1	1	1
R/W:	R/W	R/W	R/W	R/W	R/W	R/W	R/W	R/W
Bit:	15	14	13	12	11	10	9	8
	<input type="checkbox"/>	<input type="checkbox"/>	<input type="checkbox"/>	<input type="checkbox"/>	<input type="checkbox"/>	<input type="checkbox"/>	<input type="checkbox"/>	<input type="checkbox"/>
Initial value:	1	1	1	1	1	1	1	1
R/W:	R/W	R/W	R/W	R/W	R/W	R/W	R/W	R/W
Bit:	7	6	5	4	3	2	1	0
	<input type="checkbox"/>	<input type="checkbox"/>	<input type="checkbox"/>	<input type="checkbox"/>	<input type="checkbox"/>	<input type="checkbox"/>	<input type="checkbox"/>	<input type="checkbox"/>
Initial value:	1	1	1	1	1	1	1	1
R/W:	R/W	R/W	R/W	R/W	R/W	R/W	R/W	R/W

12.2.5 Timer Counters (TCNT)

The timer counters are 32-bit readable/writable registers. The TMU has three timer counters, one for each channel.

TCNT counts down upon input of a clock. The clock input is selected using the TPSC2–TPSC0 bits in the timer control register (TCR).

When a TCNT count-down results in an underflow (H'00000000 → H'FFFFFFFF), the underflow flag (UNF) in the timer control register (TCR) of the relevant channel is set. The TCOR value is simultaneously set in TCNT itself and the count-down continues from that value.

Because the internal bus for the SH7709S on-chip peripheral modules is 16 bits wide, a time lag can occur between the time when the upper 16 bits and lower 16 bits are read. Since TCNT counts sequentially, this time lag can create discrepancies between the data in the upper and lower halves. To correct the discrepancy, a buffer register is connected to TCNT so that the upper and lower halves are not read separately. The entire 32-bit data in TCNT can thus be read at once.

TCNT is initialized to H'FFFFFFFF by a power-on reset or manual reset, but is not initialized, and retains its contents, in standby mode.

Bit:	31	30	29	28	27	26	25	24
Initial value:	1	1	1	1	1	1	1	1
R/W:	R/W	R/W	R/W	R/W	R/W	R/W	R/W	R/W
Bit:	23	22	21	20	19	18	17	16
Initial value:	1	1	1	1	1	1	1	1
R/W:	R/W	R/W	R/W	R/W	R/W	R/W	R/W	R/W
Bit:	15	14	13	12	11	10	9	8
Initial value:	1	1	1	1	1	1	1	1
R/W:	R/W	R/W	R/W	R/W	R/W	R/W	R/W	R/W
Bit:	7	6	5	4	3	2	1	0
Initial value:	1	1	1	1	1	1	1	1
R/W:	R/W	R/W	R/W	R/W	R/W	R/W	R/W	R/W

12.2.6 Input Capture Register (TCPR2)

Input capture register 2 (TCPR2) is a read-only 32-bit register provided only in timer 2. Control of TCPR2 setting conditions due to the TCLK pin is affected by the input capture function bits (ICPE1/ICPE0 and CKEG1/CKEG0) in TCR2. When a TCPR2 setting indication due to the TCLK pin occurs, the value of TCNT2 is copied into TCPR2.

TCNT2 is not initialized by a power-on reset or manual reset, but is not initialized, and retains its contents, or in standby mode.

Bit:	31	30	29	28	27	26	25	24
Initial value:	—	—	—	—	—	—	—	—
R/W:	R	R	R	R	R	R	R	R
Bit:	23	22	21	20	19	18	17	16
Initial value:	—	—	—	—	—	—	—	—
R/W:	R	R	R	R	R	R	R	R
Bit:	15	14	13	12	11	10	9	8
Initial value:	—	—	—	—	—	—	—	—
R/W:	R	R	R	R	R	R	R	R
Bit:	7	6	5	4	3	2	1	0
Initial value:	—	—	—	—	—	—	—	—
R/W:	R	R	R	R	R	R	R	R

12.3 TMU Operation

Each of three channels has a 32-bit timer counter (TCNT) and a 32-bit timer constant register (TCOR). TCNT counts down. The auto-reload function enables cycle counting and counting by external events. Channel 2 has an input capture function.

12.3.1 General Operation

When the STR0–STR2 bits in the timer start register (TSTR) are set to 1, the corresponding timer counter (TCNT) starts counting. When a TCNT underflows, the UNF flag of the corresponding timer control register (TCR) is set. At this time, if the UNIE bit in TCR is 1, an interrupt request is sent to the CPU. Also at this time, the value is copied from TCOR to TCNT and the down-count operation is continued.

The count operation is set as follows (figure 12.2):

1. Select the counter clock with the TPSC2–TPSC0 bits in the timer control register (TCR). If the external clock is selected, set the TCLK pin to input mode with the TOCE bit in TOCR, and select its edge with the CKEG1 and CKEG0 bits in TCR.
2. Use the UNIE bit in TCR to set whether to generate an interrupt when TCNT underflows.
3. When using the input capture function, set the ICPE bits in TCR, including the choice of whether or not to use the interrupt function (channel 2 only).
4. Set a value in the timer constant register (TCOR) (the cycle is the set value plus 1).
5. Set the initial value in the timer counter (TCNT).
6. Set the STR bit in the timer start register (TSTR) to 1 to start operation.

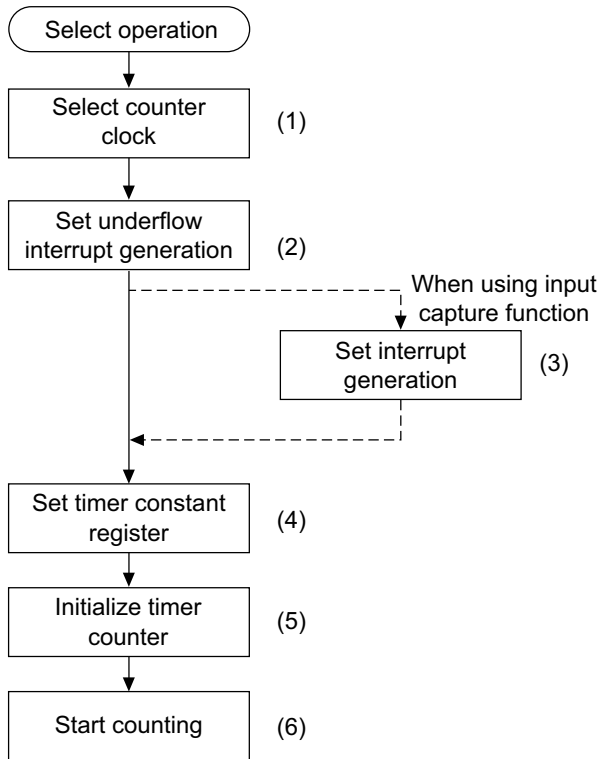

Note: When an interrupt has been generated, clear the flag in the interrupt handler that caused it. If interrupts are enabled without clearing the flag, another interrupt will be generated.

Figure 12.2 Setting the Count Operation

Auto-Reload Count Operation: Figure 12.3 shows the TCNT auto-reload operation.

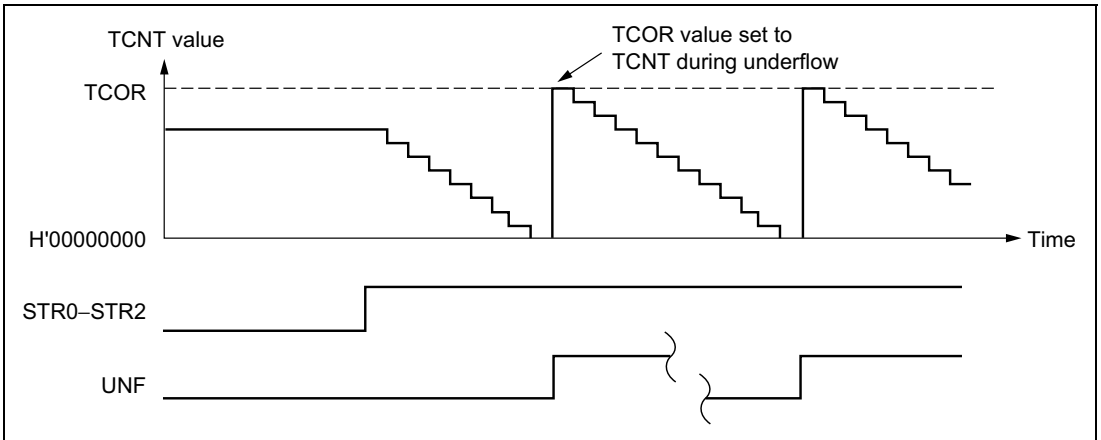

Figure 12.3 Auto-Reload Count Operation

TCNT Count Timing:

- **Internal Clock Operation:** Set the TPSC2–TPSC0 bits in TCR to select whether peripheral module clock $P\phi$ or one of the four internal clocks created by dividing it is used ($P\phi/4$, $P\phi/16$, $P\phi/64$, $P\phi/256$). Figure 12.4 shows the timing.

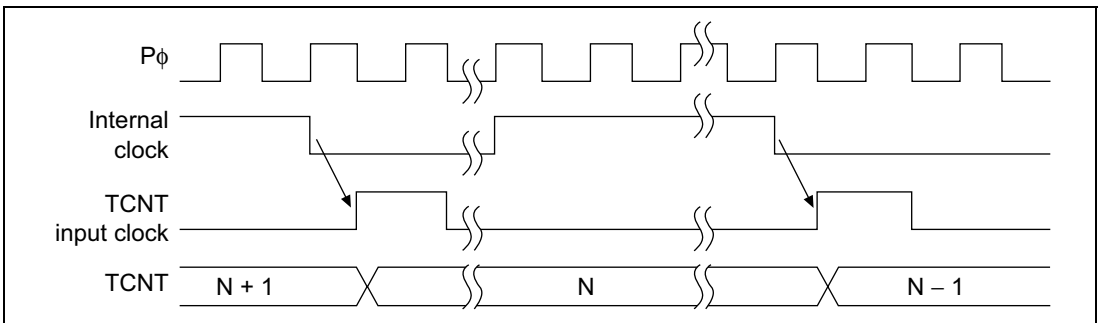

Figure 12.4 Count Timing when Operating on Internal Clock

- External Clock Operation: Set the TPSC2–TPSC0 bits in TCR to select the external clock (TCLK) as the timer clock. Use the CKEG1 and CKEG0 bits in TCR to select the detection edge. Rising, falling, or both edges may be selected. The pulse width of the external clock must be at least 1.5 peripheral module clock cycles for single edges or 2.5 peripheral module clock cycles for both edges. A shorter pulse width will result in accurate operation. Figure 12.5 shows the timing for both-edge detection.

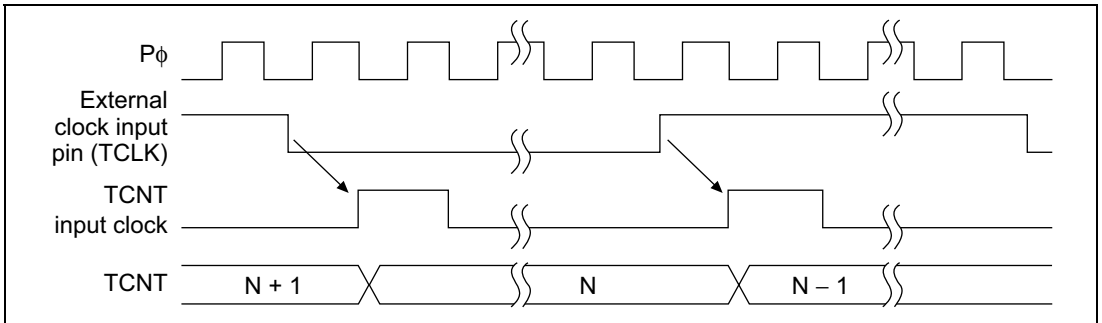

Figure 12.5 Count Timing when Operating on External Clock (Both Edges Detected)

- On-Chip RTC Clock Operation: Set the TPSC2–TPSC0 bits in TCR to select the on-chip RTC clock as the timer clock. Figure 12.6 shows the timing.

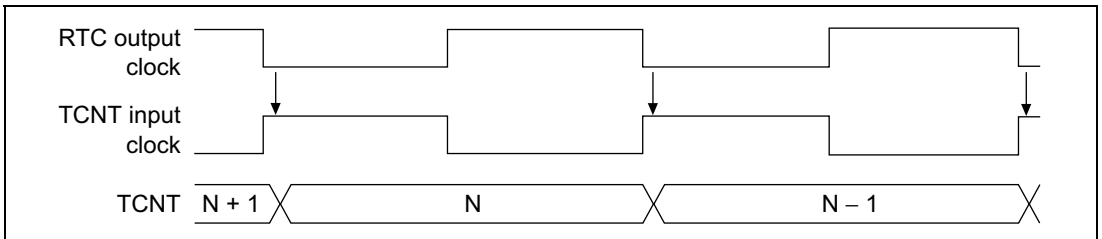

Figure 12.6 Count Timing when Operating on On-Chip RTC Clock

12.3.2 Input Capture Function

Channel 2 has an input capture function (figure 12.7). When using the input capture function, set the TCLK pin to input mode with the TCOE bit in the timer output control register (TOCR) and set the timer operation clock to internal clock or on-chip RTC clock with the TPSC2–TPSC0 bits in the timer control register (TCR2). Also, designate use of the input capture function and whether to generate interrupts on input capture with the IPCE1–IPCE0 bits in TCR2, and designate the use of either the rising or falling edge of the TCLK pin to set the timer counter (TCNT2) value into the input capture register (TCPR2) with the CKEG1–CKEG0 bits in TCR2.

The input capture function cannot be used in standby mode.

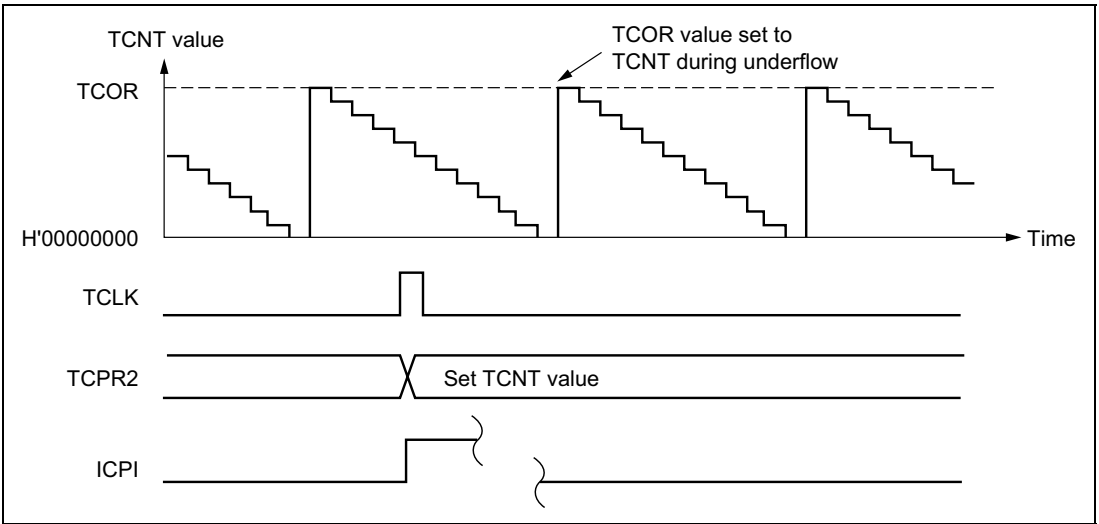

Figure 12.7 Operation Timing when Using Input Capture Function (Using TCLK Rising Edge)

12.4 Interrupts

There are two sources of TMU interrupts: underflow interrupts (TUNI) and interrupts when using the input capture function (TICPI2).

12.4.1 Status Flag Setting Timing

UNF is set to 1 when the TCNT underflows. Figure 12.8 shows the timing.

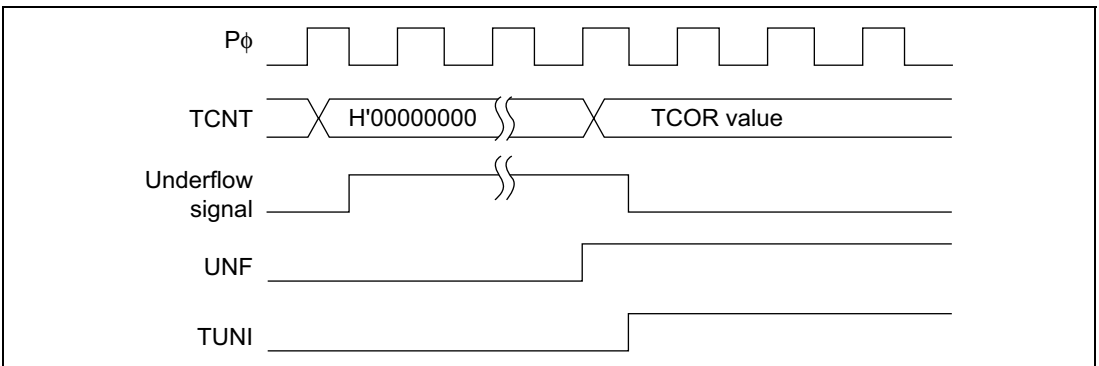

Figure 12.8 UNF Setting Timing

12.4.2 Status Flag Clearing Timing

The status flag can be cleared by writing 0 from the CPU. Figure 12.9 shows the timing.

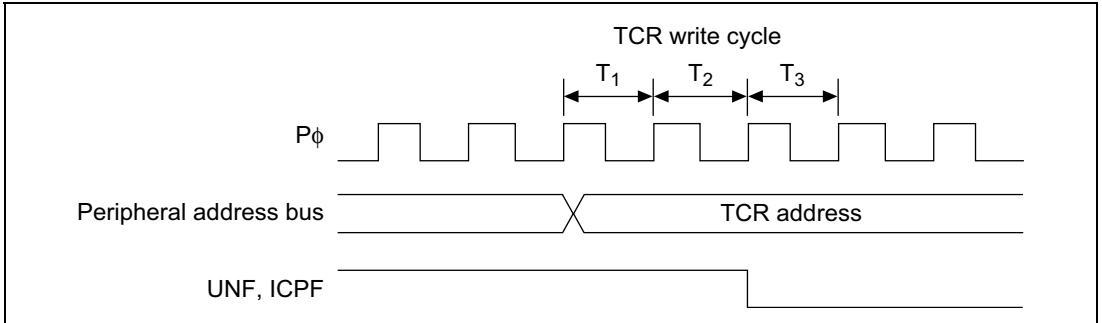

Figure 12.9 Status Flag Clearing Timing

12.4.3 Interrupt Sources and Priorities

The TMU produces underflow interrupts for each channel. When the interrupt request flag and interrupt enable bit are both set to 1, an interrupt is requested. Codes are set in the interrupt event registers (INTEVT, INTEVT2) for these interrupts and interrupt handling occurs according to the codes.

The relative priorities of channels can be changed using the interrupt controller (see section 4, Exception Handling, and section 6, Interrupt Controller (INTC)). Table 12.3 lists TMU interrupt sources.

Table 12.3 TMU Interrupt Sources

Channel	Interrupt Source	Description	Priority
0	TUNI0	Underflow interrupt 0	High
1	TUNI1	Underflow interrupt 1	↑ ↓
2	TUNI2	Underflow interrupt 2	
2	TICPI2	Input capture interrupt 2	

12.5 Usage Notes

12.5.1 Writing to Registers

Synchronization processing is not performed for timer counting during register writes. When writing to registers, always clear the appropriate start bits for the channel (STR2–STR0) in the timer start register (TSTR) to halt timer counting.

12.5.2 Reading Registers

Synchronization processing is performed for timer counting during register reads. When timer counting and register read processing are performed simultaneously, the register value before TCNT counting down (with synchronization processing) is read.

Section 13 Realtime Clock (RTC)

13.1 Overview

The SH7709S has a realtime clock (RTC) with its own 32.768-kHz crystal oscillator.

13.1.1 Features

- Clock and calendar functions (BCD display): Seconds, minutes, hours, date, day of the week, month, and year
- 1-Hz to 64-Hz timer (binary display)
- Start/stop function
- 30-second adjust function
- Alarm interrupt: Frame comparison of seconds, minutes, hours, date, day of the week, and month can be used as conditions for the alarm interrupt
- Cyclic interrupts: The interrupt cycle may be 1/256 second, 1/64 second, 1/16 second, 1/4 second, 1/2 second, 1 second, or 2 seconds
- Carry interrupt: A carry interrupt indicates when a carry occurs during a counter read
- Automatic leap year correction

13.1.2 Block Diagram

Figure 13.1 shows a block diagram of the RTC.

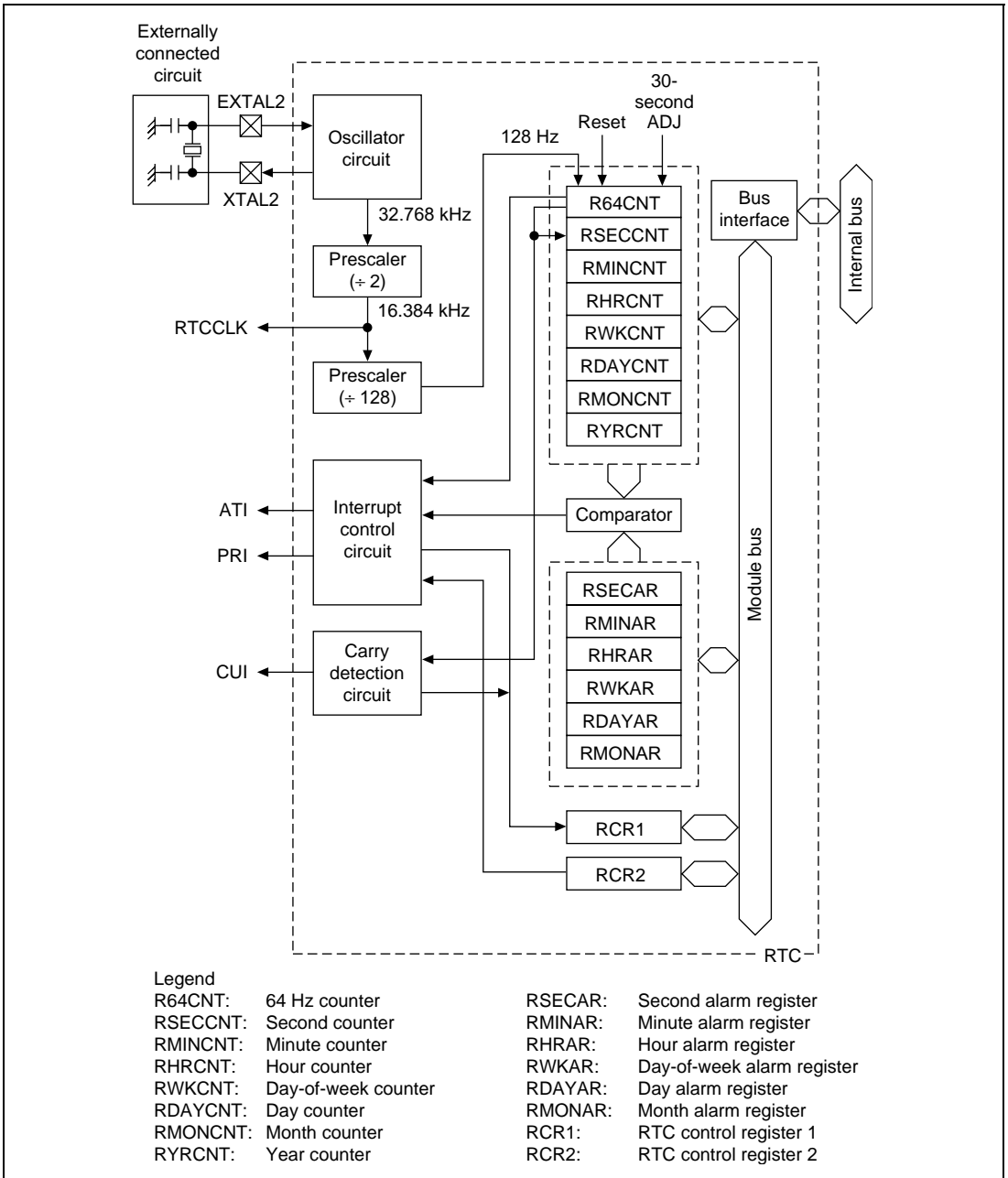

Figure 13.1 Block Diagram of RTC

13.1.3 Pin Configuration

Table 13.1 shows the RTC pin configuration.

Table 13.1 RTC Pins

Pin	Signal Name	I/O	Description
RTC oscillator crystal pin	EXTAL2	I	Connects crystal to RTC oscillator*2
RTC oscillator crystal pin	XTAL2	O	Connects crystal to RTC oscillator*2
Clock input/clock output	TCLK	I/O	External clock input pin/input capture control input pin/realtime clock (RTC) output pin (shared by TMU)
Dedicated power-supply pin for RTC	Vcc-RTC	—	Dedicated power-supply pin for RTC*1
Dedicated GND pin for RTC	Vss-RTC	—	Dedicated GND pin for RTC*1

- Notes: 1. Except in hardware standby mode, power must be supplied to all power supply pins, including these, even when only the RTC is used (including standby mode).
2. When the RTC is not used, pull EXTAL2 up (to Vcc) and make no connection for XTAL2.

13.1.4 RTC Register Configuration

Table 13.2 shows the RTC register configuration.

Table 13.2 RTC Registers

Name	Abbreviation	R/W	Initial Value	Address	Access Size
64-Hz counter	R64CNT	R	Undefined	H'FFFFFFEC0	8
Second counter	RSECCNT	R/W	Undefined	H'FFFFFFEC2	8
Minute counter	RMINCNT	R/W	Undefined	H'FFFFFFEC4	8
Hour counter	RHRCNT	R/W	Undefined	H'FFFFFFEC6	8
Day of week counter	RWKCNT	R/W	Undefined	H'FFFFFFEC8	8
Date counter	RDAYCNT	R/W	Undefined	H'FFFFFFECA	8
Month counter	RMONCNT	R/W	Undefined	H'FFFFFFECC	8
Year counter	RYRCNT	R/W	Undefined	H'FFFFFFECE	8
Second alarm register	RSECAR	R/W	Undefined*	H'FFFFFFED0	8
Minute alarm register	RMINAR	R/W	Undefined*	H'FFFFFFED2	8
Hour alarm register	RHRAR	R/W	Undefined*	H'FFFFFFED4	8
Day of week alarm register	RWKAR	R/W	Undefined*	H'FFFFFFED6	8
Date alarm register	RDAYAR	R/W	Undefined*	H'FFFFFFED8	8
Month alarm register	RMONAR	R/W	Undefined*	H'FFFFFFEDA	8
RTC control register 1	RCR1	R/W	H'00	H'FFFFFFEDC	8
RTC control register 2	RCR2	R/W	H'09	H'FFFFFFEDE	8

Note: * Only the ENB bits of each register are initialized.

13.2 RTC Registers

13.2.1 64-Hz Counter (R64CNT)

The 64-Hz counter (R64CNT) is an 8-bit read-only register that indicates the states of the RTC divider circuit, RTC prescaler, and R64CNT between 64 Hz and 1 Hz.

R64CNT is initialized to H'00 by setting the RESET bit in RTC control register 2 (RCR2) or the ADJ bit in RCR2 to 1.

R64CNT is not initialized by a power-on reset or manual reset, or in standby mode.

Bit 7 is always read as 0.

Bit:	7	6	5	4	3	2	1	0
	—	1Hz	2Hz	4Hz	8Hz	16Hz	32Hz	64Hz
Initial value:	0	—	—	—	—	—	—	—
R/W:	R	R	R	R	R	R	R	R

13.2.2 Second Counter (RSECCNT)

The second counter (RSECCNT) is an 8-bit readable/writable register used for setting/counting in the BCD-coded second section of the RTC. The count operation is performed by a carry for each second of the 64-Hz counter.

The range that can be set is 00–59 (decimal). Errant operation will result if any other value is set. Carry out write processing after halting the count operation with the START bit in RCR2.

RSECCNT is not initialized by a power-on reset or manual reset, or in standby mode.

Bit:	7	6	5	4	3	2	1	0
	—	10 seconds			1 second			
Initial value:	0	—	—	—	—	—	—	—
R/W:	R	R/W	R/W	R/W	R/W	R/W	R/W	R/W

13.2.3 Minute Counter (RMINCNT)

The minute counter (RMINCNT) is an 8-bit readable/writable register used for setting/counting in the BCD-coded minute section of the RTC. The count operation is performed by a carry for each minute of the second counter.

The range that can be set is 00–59 (decimal). Errant operation will result if any other value is set. Carry out write processing after halting the count operation with the START bit in RCR2.

RMINCNT is not initialized by a power-on reset or manual reset, or in standby mode.

Bit:	7	6	5	4	3	2	1	0
	—	10 minutes			1 minute			
Initial value:	0	—	—	—	—	—	—	—
R/W:	R	R/W	R/W	R/W	R/W	R/W	R/W	R/W

13.2.4 Hour Counter (RHRCNT)

The hour counter (RHRCNT) is an 8-bit readable/writable register used for setting/counting in the BCD-coded hour section of the RTC. The count operation is performed by a carry for each 1 hour of the minute counter.

The range that can be set is 00–23 (decimal). Errant operation will result if any other value is set. Carry out write processing after halting the count operation with the START bit in RCR2 or using a carry flag as shown in figure 13.2.

RHRCNT is not initialized by a power-on reset or manual reset, or in standby mode.

Bit:	7	6	5	4	3	2	1	0
	—	—	10 hours		1 hour			
Initial value:	0	0	—	—	—	—	—	—
R/W:	R	R	R/W	R/W	R/W	R/W	R/W	R/W

13.2.5 Day of Week Counter (RWKCNT)

The day of week counter (RWKCNT) is an 8-bit readable/writable register used for setting/counting in the BCD-coded day of week section of the RTC. The count operation is performed by a carry for each day of the date counter.

The range that can be set is 0–6 (decimal). Errant operation will result if any other value is set. Carry out write processing after halting the count operation with the START bit in RCR2.

RWKCNT is not initialized by a power-on reset or manual reset, or in standby mode.

Bit:	7	6	5	4	3	2	1	0
	—	—	—	—	—	Day of week		
Initial value:	0	0	0	0	0	—	—	—
R/W:	R	R	R	R	R	R/W	R/W	R/W

Days of the week are coded as shown in table 13.3.

Table 13.3 Day-of-Week Codes (RWKCNT)

Day of Week	Code
Sunday	0
Monday	1
Tuesday	2
Wednesday	3
Thursday	4
Friday	5
Saturday	6

13.2.6 Date Counter (RDAYCNT)

The date counter (RDAYCNT) is an 8-bit readable/writable register used for setting/counting in the BCD-coded date section of the RTC. The count operation is performed by a carry for each day of the hour counter.

The range that can be set is 01–31 (decimal). Errant operation will result if any other value is set. Carry out write processing after halting the count operation with the START bit in RCR2.

RDAYCNT is not initialized by a power-on reset or manual reset, or in standby mode.

The RDAYCNT range that can be set changes with each month and in leap years. Please confirm the correct setting.

Bit:	7	6	5	4	3	2	1	0
	—	—	10 days		1 day			
Initial value:	0	0	—	—	—	—	—	—
R/W:	R	R	R/W	R/W	R/W	R/W	R/W	R/W

13.2.7 Month Counter (RMONCNT)

The month counter (RMONCNT) is an 8-bit readable/writable register used for setting/counting in the BCD-coded month section of the RTC. The count operation is performed by a carry for each month of the date counter.

The range that can be set is 00–12 (decimal). Errant operation will result if any other value is set. Carry out write processing after halting the count operation with the START bit in RCR2.

RMONCNT is not initialized by a power-on reset or manual reset, or in standby mode.

Bit:	7	6	5	4	3	2	1	0
	—	—	—	10 months	1 month			
Initial value:	0	0	0	—	—	—	—	—
R/W:	R	R	R	R/W	R/W	R/W	R/W	R/W

13.2.8 Year Counter (RYRCNT)

The year counter (RYRCNT) is an 8-bit readable/writable register used for setting/counting in the BCD-coded year section of the RTC. The least significant 2 digits of the western calendar year are displayed. The count operation is performed by a carry for each year of the month counter.

The range that can be set is 00–99 (decimal). Errant operation will result if any other value is set. Carry out write processing after halting the count operation with the START bit in RCR2.

RYRCNT is not initialized by a power-on reset or manual reset, or in standby mode.

Leap years are recognized by dividing the year counter value by 4 and obtaining a fractional result of 0. The year counter value: 00 is included in leap years.

Bit:	7	6	5	4	3	2	1	0
	10 years				1 year			
Initial value:	—	—	—	—	—	—	—	—
R/W:	R/W	R/W	R/W	R/W	R/W	R/W	R/W	R/W

13.2.9 Second Alarm Register (RSECAR)

The second alarm register (RSECAR) is an 8-bit readable/writable register, and an alarm register corresponding to the BCD-coded second section counter RSECCNT of the RTC. When the ENB bit is set to 1, a comparison with the RSECCNT value is performed. From among the RSECAR/RMINAR/RHRAR/RWKAR/RDAYAR/RMONAR registers, the counter and alarm register comparison is performed only on those with ENB bits set to 1, and if each of those coincide, an RTC alarm interrupt is generated.

The range that can be set is 00–59 (decimal) + ENB bit. Errant operation will result if any other value is set.

The ENB bit in RSECAR is initialized to 0 by a power-on reset. The remaining RSECAR fields are not initialized and retain their contents by a manual reset, or in standby mode.

Bit:	7	6	5	4	3	2	1	0
	ENB	10 seconds			1 second			
Initial value:	0	—	—	—	—	—	—	—
R/W:	R/W	R/W	R/W	R/W	R/W	R/W	R/W	R/W

13.2.10 Minute Alarm Register (RMINAR)

The minute alarm register (RMINAR) is an 8-bit readable/writable register, and an alarm register corresponding to the BCD-coded minute section counter RMINCNT of the RTC. When the ENB bit is set to 1, a comparison with the RMINCNT value is performed. From among the RSECAR/RMINAR/RHRAR/RWKAR/RDAYAR/RMONAR registers, the counter and alarm register comparison is performed only on those with ENB bits set to 1, and if each of those coincide, an RTC alarm interrupt is generated.

The range that can be set is 00–59 (decimal) + ENB bit. Errant operation will result if any other value is set.

The ENB bit in RMINAR is initialized by a power-on reset. The remaining RMINAR fields are not initialized and retain their contents by a manual reset, or in standby mode.

Bit:	7	6	5	4	3	2	1	0
	ENB	10 minutes			1 minute			
Initial value:	0	—	—	—	—	—	—	—
R/W:	R/W	R/W	R/W	R/W	R/W	R/W	R/W	R/W

13.2.11 Hour Alarm Register (RHRAR)

The hour alarm register (RHRAR) is an 8-bit readable/writable register, and an alarm register corresponding to the BCD-coded hour section counter RHRCNT of the RTC. When the ENB bit is set to 1, a comparison with the RHRCNT value is performed. From among the RSECAR/RMINAR/RHRAR/RWKAR/RDAYAR/RMONAR registers, the counter and alarm register comparison is performed only on those with ENB bits set to 1, and if each of those coincide, an RTC alarm interrupt is generated.

The range that can be set is 00–23 (decimal) + ENB bit. Errant operation will result if any other value is set.

The ENB bit in RHRAR is initialized by a power-on reset. The remaining RHRAR fields are not initialized and retain their contents by a manual reset, or in standby mode.

Bit:	7	6	5	4	3	2	1	0
	ENB	—	10 hours		1 hour			
Initial value:	0	0	—	—	—	—	—	—
R/W:	R/W	R	R/W	R/W	R/W	R/W	R/W	R/W

13.2.12 Day of Week Alarm Register (RWKAR)

The day of week alarm register (RWKAR) is an 8-bit readable/writable register, and an alarm register corresponding to the BCD-coded day of week section counter RWKCNT of the RTC. When the ENB bit is set to 1, a comparison with the RWKCNT value is performed. From among the RSECAR/RMINAR/RHRAR/RWKAR/RDAYAR/RMONAR registers, the counter and alarm register comparison is performed only on those with ENB bits set to 1, and if each of those coincide, an RTC alarm interrupt is generated.

The range that can be set is 0–6 (decimal) + ENB bit. Errant operation will result if any other value is set.

The ENB bit in RWKAR is initialized by a power-on reset. The remaining RWKAR fields are not initialized and retain their contents by a manual reset, or in standby mode.

Bit:	7	6	5	4	3	2	1	0
	ENB	—	—	—	—	Day of week		
Initial value:	0	0	0	0	0	—	—	—
R/W:	R/W	R	R	R	R	R/W	R/W	R/W

Days of the week are coded as shown in table 13.4.

Table 13.4 Day-of-Week Codes (RWKAR)

Day of Week	Code
Sunday	0
Monday	1
Tuesday	2
Wednesday	3
Thursday	4
Friday	5
Saturday	6

13.2.13 Date Alarm Register (RDAYAR)

The date alarm register (RDAYAR) is an 8-bit readable/writable register, and an alarm register corresponding to the BCD-coded date section counter RDAYCNT of the RTC. When the ENB bit is set to 1, a comparison with the RDAYCNT value is performed. From among the registers RSECAR, RMINAR, RHRAR, RWKAR, RDAYAR, RMONAR, the counter and alarm register comparison is performed only on those with ENB bits set to 1, and if each of those coincide, an RTC alarm interrupt is generated.

The range that can be set is 01–31 (decimal) + ENB bit. Errant operation will result if any other value is set. The RDAYCNT range that can be set changes with some months and in leap years. Please confirm the correct setting.

The ENB bit in RDAYAR is initialized by a power-on reset. The remaining RDAYAR fields are not initialized and retain their contents by a manual reset, or in standby mode.

Bit:	7	6	5	4	3	2	1	0
	ENB	—	10 days		1 day			
Initial value:	0	0	—	—	—	—	—	—
R/W:	R/W	R	R/W	R/W	R/W	R/W	R/W	R/W

13.2.14 Month Alarm Register (RMONAR)

The month alarm register (RMONAR) is an 8-bit readable/writable register, and an alarm register corresponding to the BCD-coded month section counter RMONCNT of the RTC. When the ENB bit is set to 1, a comparison with the RMONCNT value is performed. From among the registers RSECAR, RMINAR, RHRAR, RWKAR, RDAYAR, RMONAR, the counter and alarm register comparison is performed only on those with ENB bits set to 1, and if each of those coincide, an RTC alarm interrupt is generated.

The range that can be set is 01–12 (decimal) + ENB bit. Errant operation will result if any other value is set.

The ENB bit in RMONAR is initialized by a power-on reset. The remaining RMONAR fields are not initialized and retain their contents by a manual reset, or in standby mode.

Bit:	7	6	5	4	3	2	1	0
	ENB	—	—	10 months	1 month			
Initial value:	0	0	0	—	—	—	—	—
R/W:	R/W	R	R	R/W	R/W	R/W	R/W	R/W

13.2.15 RTC Control Register 1 (RCR1)

The RTC control register 1 (RCR1) is an 8-bit readable/writable register that affects carry flags and alarm flags. It also selects whether to generate interrupts for each flag. Because flags are sometimes set after an operand read, do not use this register in read-modify-write processing.

RCR1 is initialized to H'00 by a power-on reset or a manual reset. In a manual reset, all bits are initialized to H'00 except for the CF flag, which is undefined. When using the CF flag, it must be initialized beforehand. This register is not initialized in standby mode.

Bit:	7	6	5	4	3	2	1	0
	CF	—	—	CIE	AIE	—	—	AF
Initial value:	0	0	0	0	0	0	0	0
R/W:	R/W	R	R	R/W	R/W	R	R	R/W

Bit 7—Carry Flag (CF): Status flag that indicates that a carry has occurred. Setting CF to 1 indicates reading of a counter register value has occurred when (1) the second counter is carried or (2) the 64-Hz counter is carried. A count register value read at this time cannot be guaranteed; another read is required.

Bit 7: CF	Description
0	No count up of R64CNT or RSECCNT Clearing condition: When 0 is written to CF (Initial value)
1	Count up of R64CNT or RSECCNT Setting condition: When 1 is written to CF

Bits 6, 5, 2, and 1—Reserved: These bits are always read as 0. The write value should always be 0.

Bit 4—Carry Interrupt Enable Flag (CIE): When the carry flag (CF) is set to 1, the CIE bit enables interrupts.

Bit 4: CIE	Description
0	A carry interrupt is not generated when the CF flag is set to 1 (Initial value)
1	A carry interrupt is generated when the CF flag is set to 1

Bit 3—Alarm Interrupt Enable Flag (AIE): When the alarm flag (AF) is set to 1, the AIE bit allows interrupts.

Bit 3: AIE	Description
0	An alarm interrupt is not generated when the AF flag is set to 1 (Initial value)
1	An alarm interrupt is generated when the AF flag is set to 1

Bit 0—Alarm Flag (AF): The AF flag is set to 1 when the alarm time set in an alarm register (only registers with ENB bit set to 1) matches the clock and calendar time. This flag is cleared to 0 when 0 is written, but holds its previous value when 1 is written.

Bit 0: AF	Description
0	Clock/calendar and alarm register have not matched since last reset to 0 Clearing condition: When 0 is written to AF (Initial value)
1	Setting condition: Clock/calendar and alarm register have matched (only registers with ENB set)*

Note: * Contents do not change when 1 is written to AF.

13.2.16 RTC Control Register 2 (RCR2)

The RTC control register 2 (RCR2) is an 8-bit readable/writable register for periodic interrupt control, 30-second adjustment ADJ, divider circuit RESET, and RTC count start/stop control. It is initialized to H'09 by a power-on reset. It is initialized except for RTCEN and START by a manual reset. It is not initialized, and retains its contents, in standby mode.

Bit:	7	6	5	4	3	2	1	0
	PEF	PES2	PES1	PES0	RTCEN	ADJ	RESET	START
Initial value:	0	0	0	0	1	0	0	1
R/W:	R/W	R/W	R/W	R/W	R/W	R/W	R/W	R/W

Bit 7—Periodic Interrupt Flag (PEF): Indicates interrupt generation with the period designated by the PES bits. When set to 1, PEF generates periodic interrupts.

Bit 7: PEF	Description
0	Interrupts not generated with the period designated by the PES bits Clearing condition: When 0 is written to PEF (Initial value)
1	Interrupts generated with the period designated by the PES bits Setting condition: When 1 is written to PEF

Bits 6 to 4—Periodic Interrupt Flags (PES2-PES0): Specify the periodic interrupt.

Bit 6: PES2	Bit 5: PES1	Bit 4: PES0	Description
0	0	0	No periodic interrupts generated (Initial value)
		1	Periodic interrupt generated every 1/256 second
	1	0	Periodic interrupt generated every 1/64 second
		1	Periodic interrupt generated every 1/16 second
1	0	0	Periodic interrupt generated every 1/4 second
		1	Periodic interrupt generated every 1/2 second
	1	0	Periodic interrupt generated every 1 second
		1	Periodic interrupt generated every 2 seconds

Bit 3—RTCEN: Controls the operation of the crystal oscillator for the RTC.

Bit 3: RTCEN	Description
0	Crystal oscillator for RTC is halted
1	Crystal oscillator for RTC runs (Initial value)

Bit 2—30 Second Adjustment (ADJ): When 1 is written to the ADJ bit, times of 29 seconds or less will be rounded to 00 seconds and 30 seconds or more to 1 minute. The divider circuit, RTC prescaler, and R64CNT will be simultaneously reset. This bit is always read as 0. The maximum duration between when the ADJ bit is set to 1 and when the new setting is reflected in the readout value from the seconds counter (RSECCNT) is approximately 91.6 μ s (when a 32.768 kHz quartz oscillator is connected to the EXTAL2 pin).

Bit 2: ADJ	Description
0	Runs normally (Initial value)
1 (Write)	30-second adjustment

Bit 1—Reset (RESET): When 1 is written, initializes the divider circuit (RTC prescaler and R64CNT). This bit is always read as 0.

Bit 1: RESET	Description
0	Runs normally (Initial value)
1 (Write)	Divider circuit is reset

Bit 0—Start Bit (START): Halts and restarts the counter (clock).

Bit 0: START	Description
0	Second/minute/hour/day/week/month/year counter halts
1	Second/minute/hour/day/week/month/year counter runs normally (Initial value)

Note: The 64-Hz counter always runs unless stopped with the RTCEN bit.

13.3 RTC Operation

13.3.1 Initial Settings of Registers after Power-On

All the registers should be set after the power is turned on.

13.3.2 Setting the Time

Figure 13.2 shows how to set the time when the clock is stopped. This works when the entire calendar or clock is to be set. Programming can be easily performed.

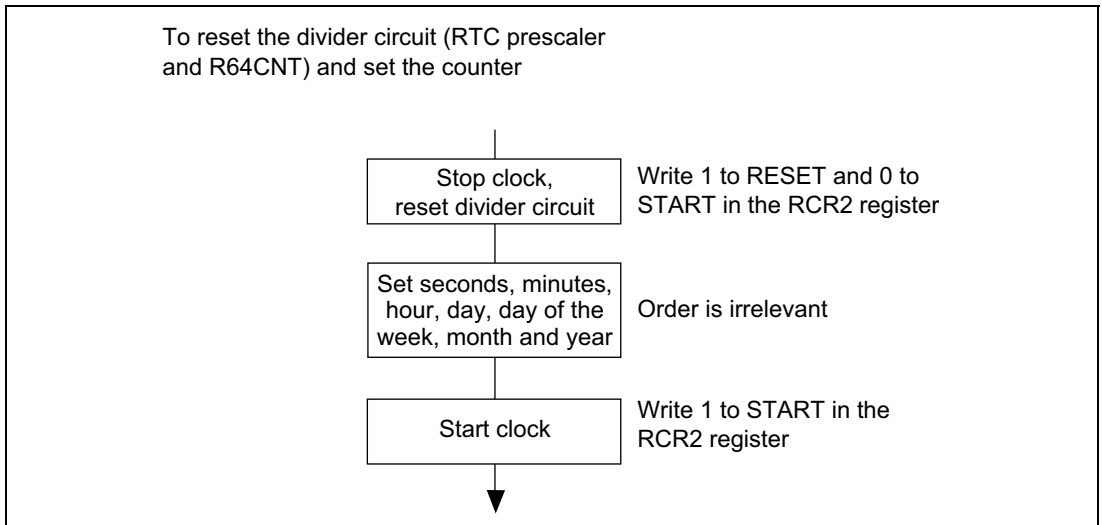

Figure 13.2 Setting the Time

13.3.3 Reading the Time

Figure 13.3 shows how to read the time. If a carry occurs while reading the time, the correct time will not be obtained, so it must be read again. Part (a) in figure 13.3 shows the method of reading the time without using interrupts; part (b) in figure 13.3 shows the method using carry interrupts. To keep programming simple, method (a) should normally be used.

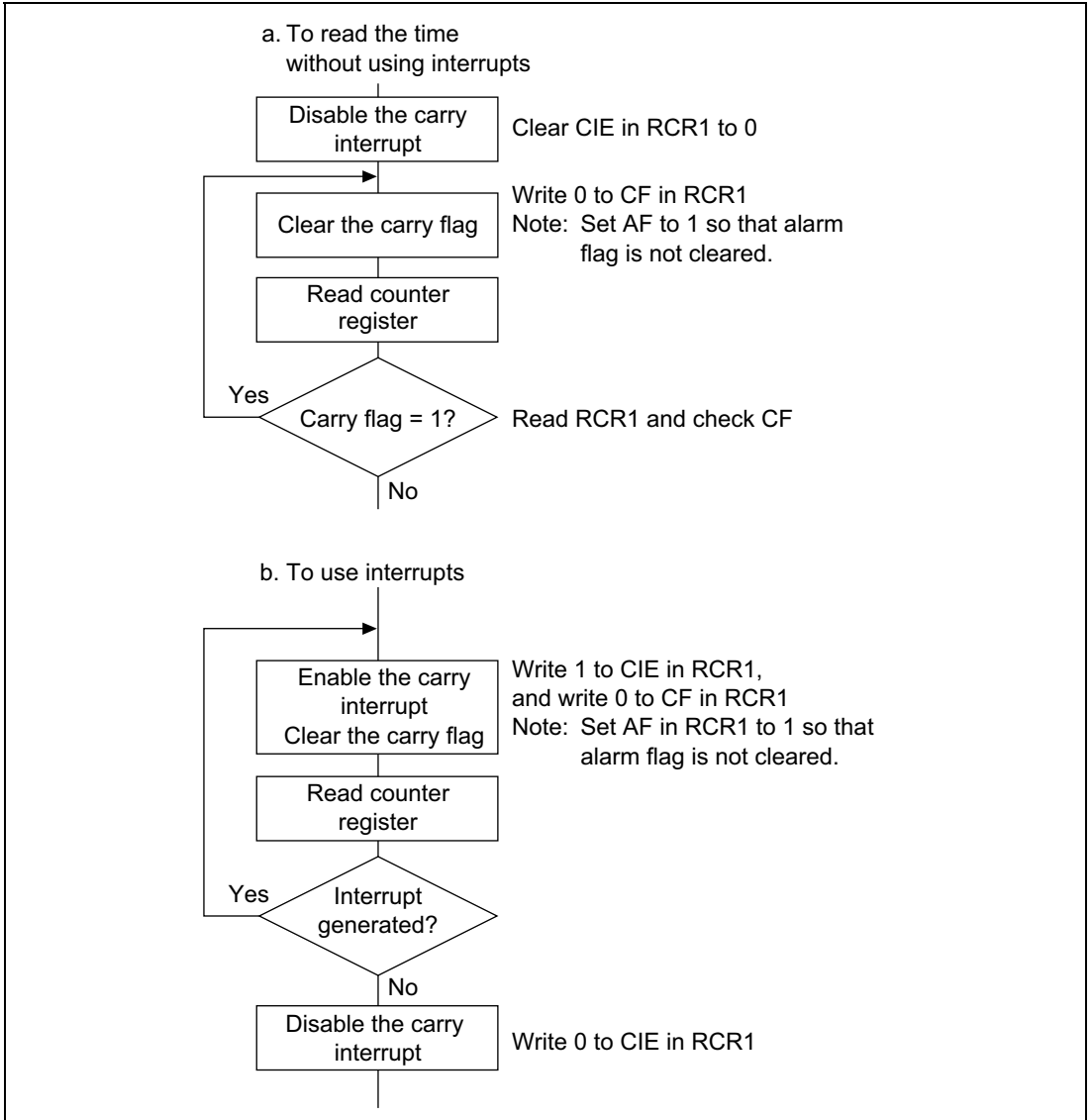

Figure 13.3 Reading the Time

13.3.4 Alarm Function

Figure 13.4 shows how to use the alarm function.

Alarms can be generated using seconds, minutes, hours, day of the week, date, month, or any combination of these. Set the ENB bit (bit 7) to 1 in the register to which the alarm applies, and then set the alarm time in the lower bits. Clear the ENB bit to 0 in registers to which the alarm does not apply.

When the clock and alarm times match, 1 is set in the AF bit (bit 0) in RCR1. Alarm detection can be checked by reading this bit, but normally it is done by interrupt. If 1 is placed in the AIE bit (bit 3) in RCR1, an interrupt is generated when an alarm occurs.

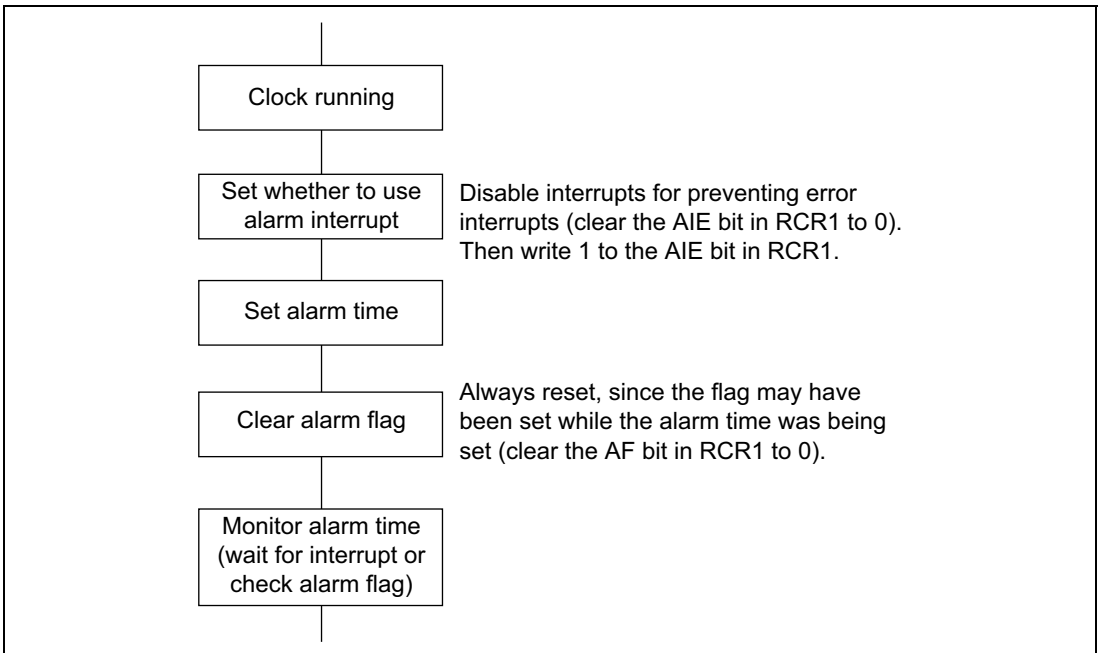

Figure 13.4 Using the Alarm Function

13.3.5 Crystal Oscillator Circuit

Crystal oscillator circuit constants (recommended values) are shown in table 13.5, and the RTC crystal oscillator circuit in figure 13.5.

Table 13.5 Recommended Oscillator Circuit Constants (Recommended Values)

fosc	C_{in}	C_{out}
32.768 kHz	10 to 22 pF	10 to 22 pF

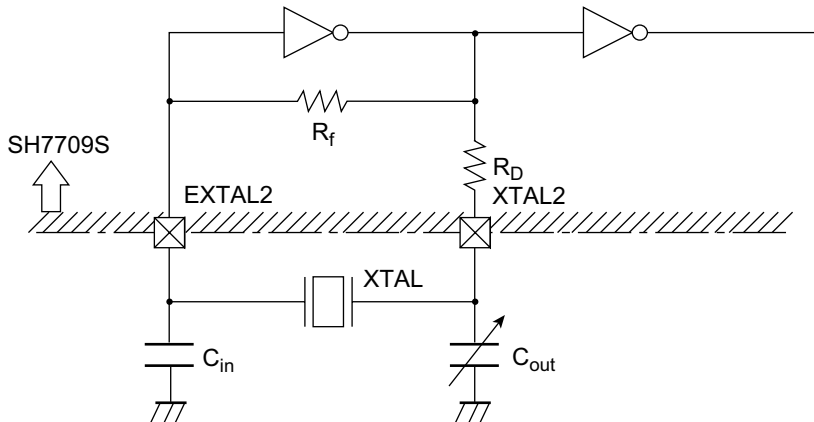

- Notes:
1. Select either the C_{in} or C_{out} side for the frequency adjustment variable capacitor according to requirements such as frequency range, degree of stability, etc.
 2. Built-in resistance value R_f (Typ value) = 10 M Ω , R_D (Typ value) = 400 k Ω
 3. C_{in} and C_{out} values include floating capacitance due to the wiring. Take care when using a ground plane.
 4. The crystal oscillation settling time depends on the mounted circuit constants, floating capacitance, etc., and should be decided after consultation with the crystal resonator manufacturer.
 5. Place the crystal resonator and load capacitors C_{in} and C_{out} as close as possible to the chip.
(Correct oscillation may not be possible if there is externally induced noise in the EXTAL2 and XTAL2 pins.)
 6. Ensure that the crystal resonator connection pin (EXTAL2, XTAL2) wiring is routed as far away as possible from other power lines (except GND) and signal lines.

Figure 13.5 Example of Crystal Oscillator Circuit Connection

13.4 Usage Notes

13.4.1 Register Writing during RTC Count

The following RTC registers cannot be written to during an RTC count (while bit 0 = 1 in RCR2).

RSECCNT, RMINCNT, RHRCNT, RDAYCNT, RWKCNT, RMONCNT, RYRCNT

The RTC count must be halted before writing to any of the above registers.

13.4.2 Use of Realtime Clock (RTC) Periodic Interrupts

The method of using the periodic interrupt function is shown in figure 13.6.

A periodic interrupt can be generated periodically at the interval set by the periodic interrupt enable flag (PES) in RTC control register 2 (RCR2). When the time set by the periodic interrupt enable flag (PES) has elapsed, the periodic interrupt flag (PEF) is set to 1.

The periodic interrupt flag (PEF) is cleared to 0 upon periodic interrupt generation when the periodic interrupt enable flag (PES) is set. Periodic interrupt generation can be confirmed by reading this bit, but normally the interrupt function is used.

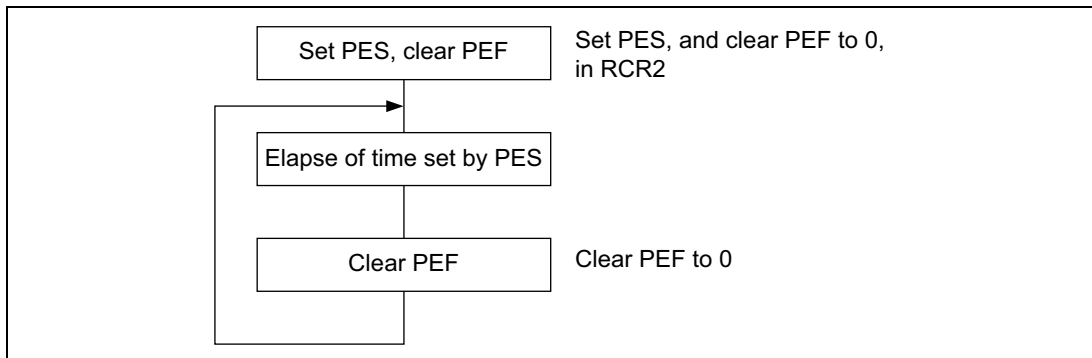

Figure 13.6 Using Periodic Interrupt Function

13.4.3 Precautions when Using RTC Module Standby

Before switching the RTC to module standby, access at least one among the registers RTC, SCI, and TMU.

Section 14 Serial Communication Interface (SCI)

14.1 Overview

The SH7709S has an on-chip serial communication interface (SCI) that supports both asynchronous and clock synchronous serial communication. It also has a multiprocessor communication function for serial communication among two or more processors. The SCI supports a smart card interface, which is a serial communication feature for IC card interfaces that conforms to the ISO/IEC standard 7816-3 for identification cards. See section 15, Smart Card Interface, for more information.

14.1.1 Features

Selection of asynchronous or synchronous as the serial communication mode.

- Asynchronous mode:
 - Serial data communication is synchronized by start-stop in character units. The SCI can communicate with a universal asynchronous receiver/transmitter (UART), an asynchronous communication interface adapter (ACIA), or any other communications chip that employs a standard asynchronous serial system. It can also communicate with two or more other processors using the multiprocessor communication function. There are 12 selectable serial data communication formats.
 - Data length: 7 or 8 bits
 - Stop bit length: 1 or 2 bits
 - Parity: Even, odd, or none
 - Multiprocessor bit: 1 or 0
 - Receive error detection: Parity, overrun, and framing errors
 - Break detection: By reading the RxD level directly from the SC port data register (SCPDR) when a framing error occurs
- Synchronous mode:
 - Serial data communication is synchronized with a clock signal. The SCI can communicate with other chips having a synchronous communication function. There is one serial data communication format.
 - Data length: 8 bits
 - Receive error detection: Overrun errors
- Full duplex communication: The transmitting and receiving sections are independent, so the SCI can transmit and receive simultaneously. Both sections use double buffering, so continuous data transfer is possible in both the transmit and receive directions.
- On-chip baud rate generator with selectable bit rates

- Internal or external transmit/receive clock source: From either baud rate generator (internal) or SCK pin (external)
- Four types of interrupts: Transmit-data-empty, transmit-end, receive-data-full, and receive-error interrupts are requested independently.
- When the SCI is not in use, it can be stopped by halting the clock supplied to it, saving power.

14.1.2 Block Diagram

Figure 14.1 shows a block diagram of the SCI.

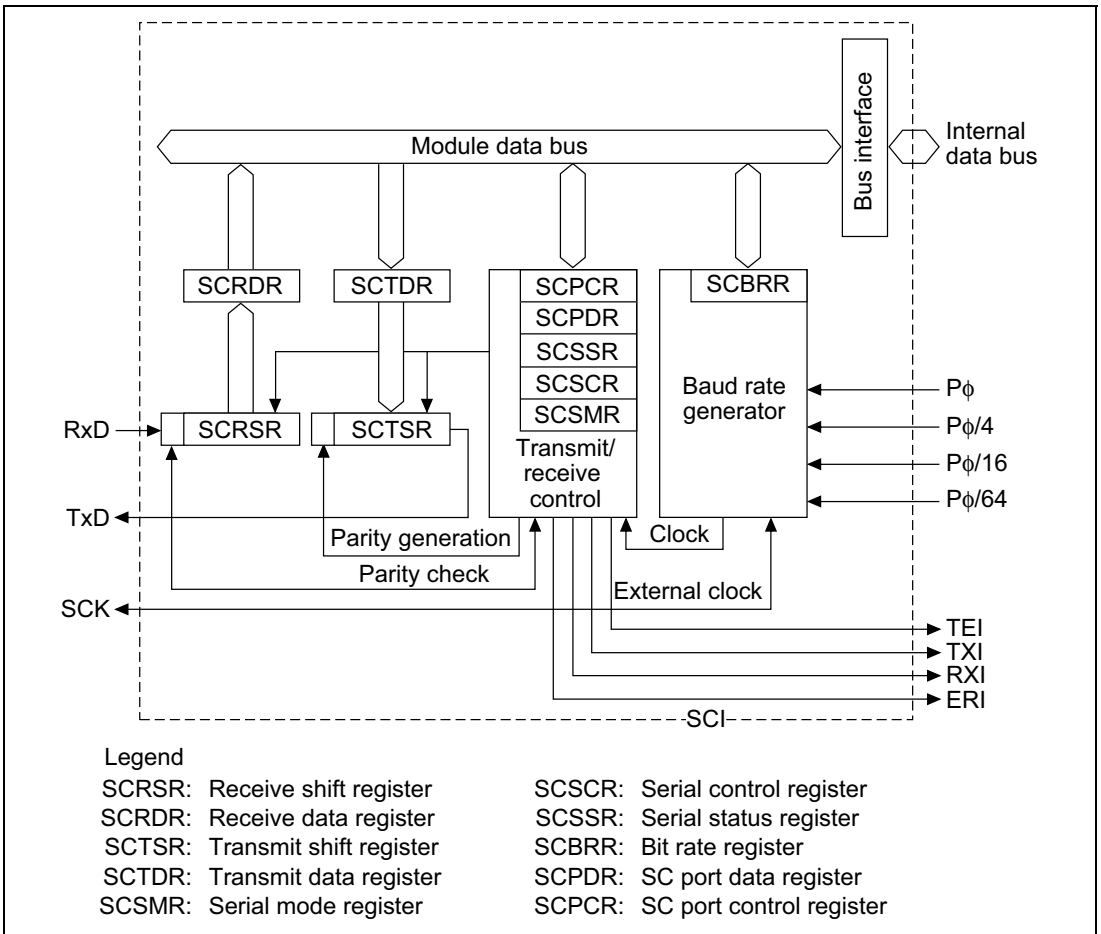

Figure 14.1 Block Diagram of SCI

Figures 14.2, 14.3, and 14.4 show block diagrams of the SCI I/O port pins.

SCIF pin I/O and data control is performed by bits 11 to 8 of SCPCR and bits 5 and 4 of SCPDR. For details, see section 14.2.8, SC Port Control Register (SCPCR)/SC Port Data Register (SCPDR).

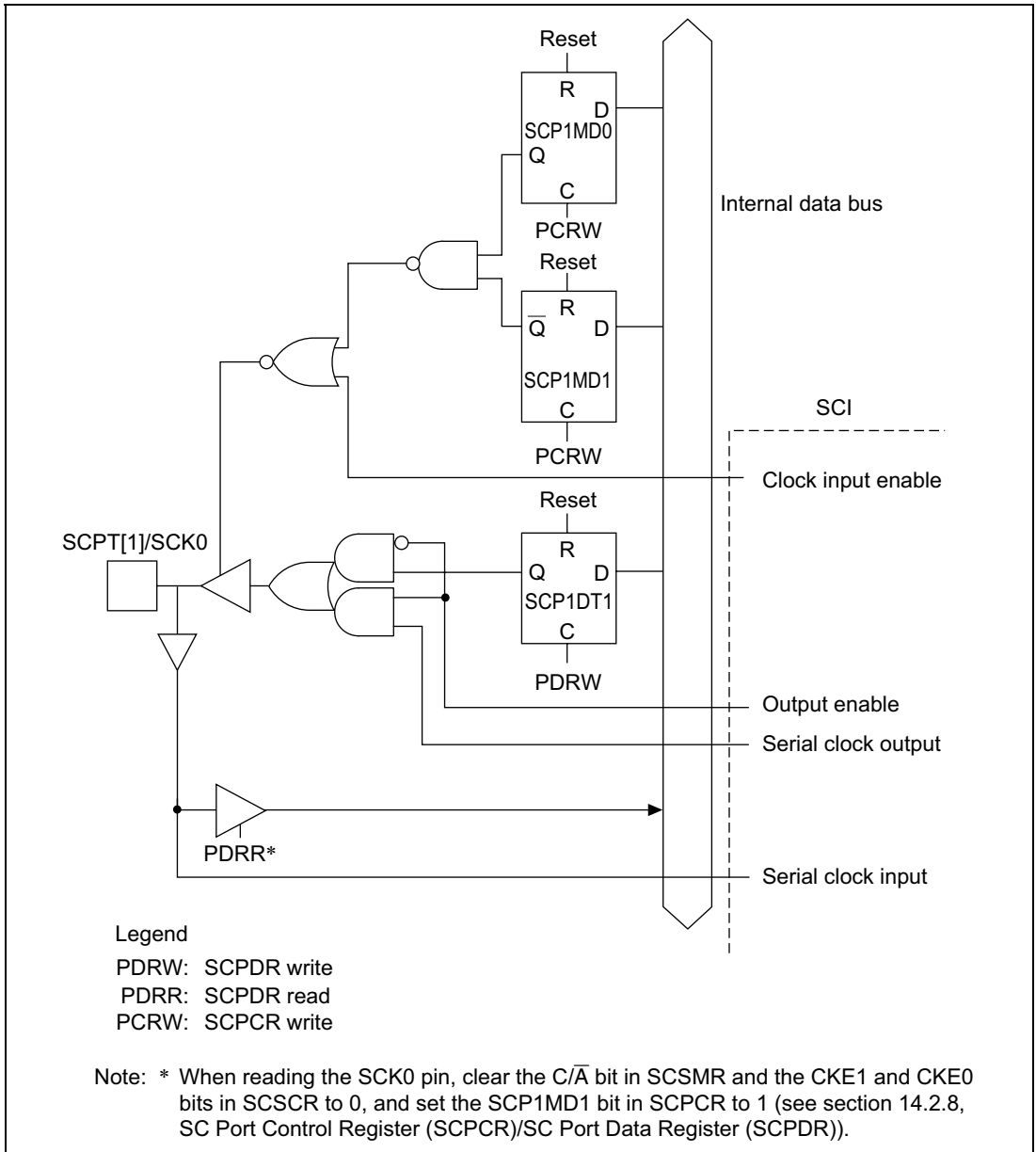

Figure 14.2 SCPT[1]/SCK0 Pin

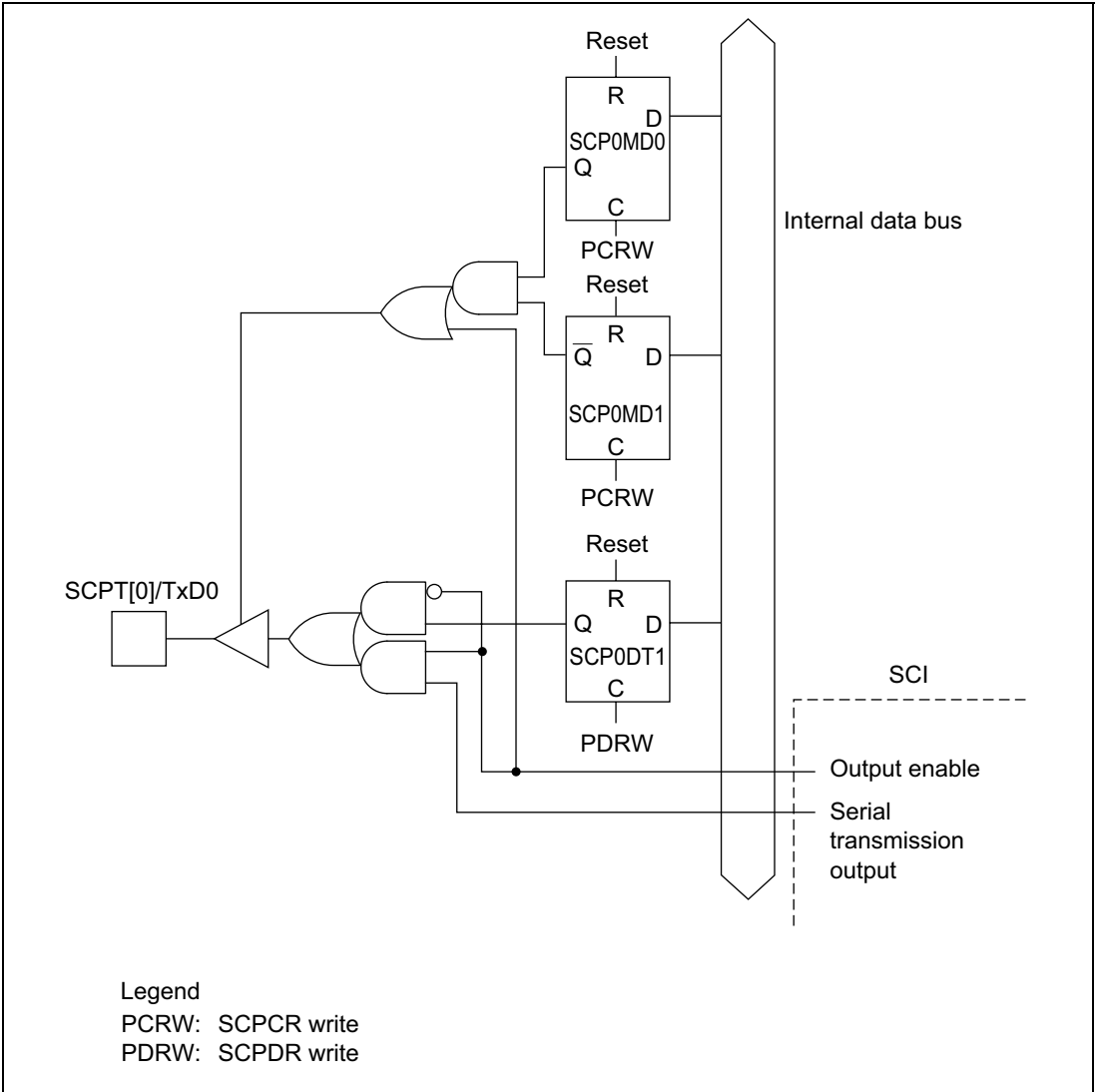

Figure 14.3 SCPT[0]/TxD0 Pin

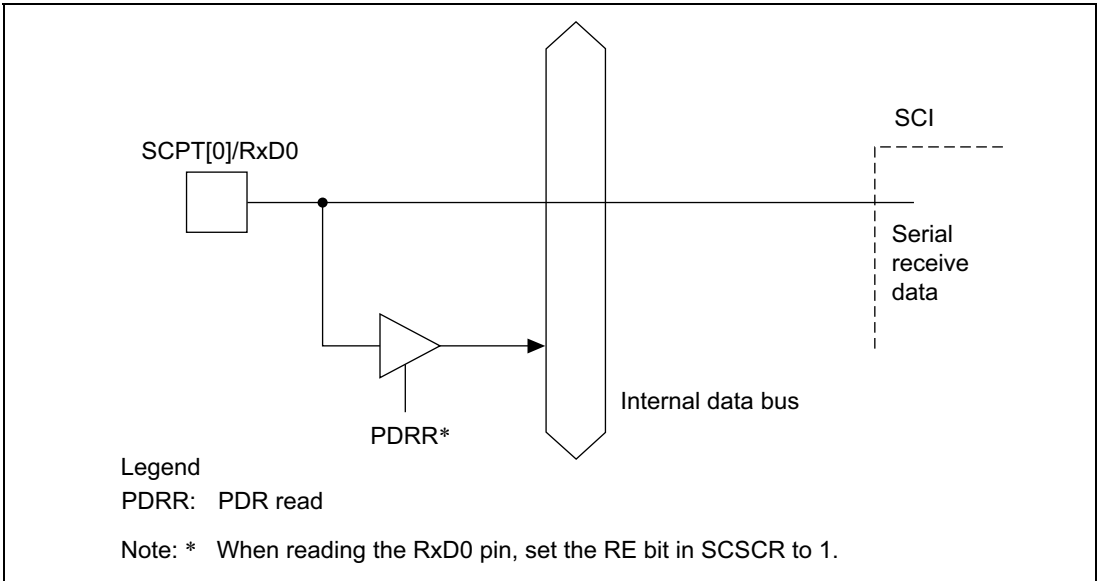

Figure 14.4 SCPT[0]/RxD0 Pin

14.1.3 Pin Configuration

The SCI has the serial pins summarized in table 14.1.

Table 14.1 SCI Pins

Pin Name	Abbreviation	I/O	Function
Serial clock pin	SCK0	I/O	Clock I/O
Receive data pin	RxD0	Input	Receive data input
Transmit data pin	TxD0	Output	Transmit data output

Note: These pins are made to function as serial pins by performing SCI operation settings with the TE, RE, CKEI, and CKE0 bits in SCSCR and the C/A bit in SCSMR. Break state transmission and detection can be performed by means of the SCI's SCSPTR register.

14.1.4 Register Configuration

Table 14.2 summarizes the SCI internal registers. These registers select the communication mode (asynchronous or synchronous), specify the data format and bit rate, and control the transmitter and receiver sections.

Table 14.2 SCI Registers

Name	Abbreviation	R/W	Initial Value	Address	Access size
Serial mode register	SCSMR	R/W	H'00	H'FFFFFFE80	8
Bit rate register	SCBRR	R/W	H'FF	H'FFFFFFE82	8
Serial control register	SCSCR	R/W	H'00	H'FFFFFFE84	8
Transmit data register	SCTDR	R/W	H'FF	H'FFFFFFE86	8
Serial status register	SCSSR	R/(W)*	H'84	H'FFFFFFE88	8
Receive data register	SCRDR	R	H'00	H'FFFFFFE8A	8
SC port data register	SCPDR	R/W	H'00	H'04000136 (H'A4000136)*2	8
SC port control register	SCPCR	R/W	H'A888	H'04000116 (H'A4000116)*2	16

Notes: These registers are located in area 1 of physical space. Therefore, when the cache is on, either access these registers from the P2 area of logical space or else make an appropriate setting using the MMU so that these registers are not cached.

1. The only value that can be written is 0 to clear the flags.
2. When address translation by the MMU does not apply, the address in parentheses should be used.

14.2 Register Descriptions

14.2.1 Receive Shift Register (SCRSR)

The receive shift register (SCRSR) receives serial data. Data input at the RxD pin is loaded into SCRSR in the order received, LSB (bit 0) first, converting the data to parallel form. When one byte has been received, it is automatically transferred to SCRDR. The CPU cannot read or write to SCRSR directly.

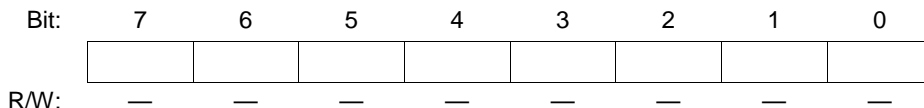

14.2.2 Receive Data Register (SCRDR)

The receive data register (SCRDR) stores serial receive data. The SCI completes the reception of one byte of serial data by moving the received data from the receive shift register (SCRSR) into SCRDR for storage. SCRSR is then ready to receive the next data. This double buffering allows the SCI to receive data continuously.

The CPU can read but not write to SCRDR. SCRDR is initialized to H'00 by a reset and in standby or module standby mode.

Bit:	7	6	5	4	3	2	1	0
Initial value:	0	0	0	0	0	0	0	0
R/W:	R	R	R	R	R	R	R	R

14.2.3 Transmit Shift Register (SCTSR)

The transmit shift register (SCTSR) transmits serial data. The SCI loads transmit data from the transmit data register (SCTDR) into SCTSR, then transmits the data serially from the TxD pin, LSB (bit 0) first. After transmitting one-byte data, the SCI automatically loads the next transmit data from SCTDR into SCTSR and starts transmitting again. If the TDRE bit in SCSSR is 1, however, the SCI does not load the SCTDR contents into SCTSR. The CPU cannot read or write to SCTSR directly.

Bit:	7	6	5	4	3	2	1	0
R/W:	—	—	—	—	—	—	—	—

14.2.4 Transmit Data Register (SCTDR)

The transmit data register (SCTDR) is an 8-bit register that stores data for serial transmission. When the SCI detects that the transmit shift register (SCTSR) is empty, it moves transmit data written in SCTDR into SCTSR and starts serial transmission. Continuous serial transmission is possible by writing the next transmit data in SCTDR during serial transmission from SCTSR.

The CPU can always read and write to SCTDR. SCTDR is initialized to H'FF by a reset and in standby or module standby mode.

Bit:	7	6	5	4	3	2	1	0
Initial value:	1	1	1	1	1	1	1	1
R/W:	R/W	R/W	R/W	R/W	R/W	R/W	R/W	R/W

14.2.5 Serial Mode Register (SCSMR)

The serial mode register (SCSMR) is an 8-bit register that specifies the SCI serial communication format and selects the clock source for the baud rate generator.

The CPU can always read and write to SCSMR. SCSMR is initialized to H'00 by a reset and in standby or module standby mode.

Bit:	7	6	5	4	3	2	1	0
	C/ \bar{A}	CHR	PE	O/ \bar{E}	STOP	MP	CKS1	CKS0
Initial value:	0	0	0	0	0	0	0	0
R/W:	R/W	R/W	R/W	R/W	R/W	R/W	R/W	R/W

Bit 7—Communication Mode (C/ \bar{A}): Selects whether the SCI operates in asynchronous or synchronous mode.

Bit 7: C/ \bar{A}	Description
0	Asynchronous mode (Initial value)
1	Synchronous mode

Bit 6—Character Length (CHR): Selects 7-bit or 8-bit data in asynchronous mode. In the synchronous mode, the data length is always eight bits, regardless of the CHR setting.

Bit 6: CHR	Description
0	8-bit data (Initial value)
1	7-bit data*

Note: * When 7-bit data is selected, the MSB (bit 7) of the transmit data register (SCTDR) is not transmitted.

Bit 5—Parity Enable (PE): Selects whether to add a parity bit to transmit data and to check the parity of receive data, in asynchronous mode. In synchronous mode, a parity bit is neither added nor checked, regardless of the PE setting.

Bit 5: PE	Description
0	Parity bit not added or checked (Initial value)
1	Parity bit added and checked*

Note: * When PE is set to 1, an even or odd parity bit is added to transmit data, depending on the parity mode (O/\bar{E}) setting. Receive data parity is checked according to the even/odd (O/\bar{E}) mode setting.

Bit 4—Parity Mode (O/\bar{E}): Selects even or odd parity when parity bits are added and checked. The O/\bar{E} setting is used only in asynchronous mode and only when the parity enable bit (PE) is set to 1 to enable parity addition and checking. The O/\bar{E} setting is ignored in synchronous mode, or in asynchronous mode when parity addition and checking is disabled.

Bit 4: O/\bar{E}	Description
0	Even parity* ¹ (Initial value)
1	Odd parity* ²

- Notes:
1. If even parity is selected, the parity bit is added to transmit data to make an even number of 1s in the transmitted character and parity bit combined. Receive data is checked to see if it has an even number of 1s in the received character and parity bit combined.
 2. If odd parity is selected, the parity bit is added to transmit data to make an odd number of 1s in the transmitted character and parity bit combined. Receive data is checked to see if it has an odd number of 1s in the received character and parity bit combined.

Bit 3—Stop Bit Length (STOP): Selects one or two bits as the stop bit length in asynchronous mode. This setting is used only in asynchronous mode. It is ignored in synchronous mode because no stop bits are added.

When receiving, only the first stop bit is checked, regardless of the STOP bit setting. If the second stop bit is 1, it is treated as a stop bit, but if the second stop bit is 0, it is treated as the start bit of the next incoming character.

Bit 3: STOP	Description	
0	One stop bit* ¹	(Initial value)
1	Two stop bits* ²	

Notes: 1. When transmitting, a single 1-bit is added at the end of each transmitted character.
 2. When transmitting, two 1-bits are added at the end of each transmitted character.

Bit 2—Multiprocessor Mode (MP): Selects multiprocessor format. When multiprocessor format is selected, settings of the parity enable (PE) and parity mode (O/ \bar{E}) bits are ignored. The MP bit setting is used only in asynchronous mode; it is ignored in synchronous mode. For the multiprocessor communication function, see section 14.3.3, Multiprocessor Communication.

Bit 2: MP	Description	
0	Multiprocessor function disabled	(Initial value)
1	Multiprocessor format selected	

Bits 1 and 0—Clock Select 1 and 0 (CKS1, CKS0): Select the internal clock source of the on-chip baud rate generator. Four clock sources are available. $P\phi$, $P\phi/4$, $P\phi/16$ and $P\phi/64$ can be set according to the setting of the CKS1 and CKS0 bits. For further information on the clock source, bit rate register settings, and baud rate, see section 14.2.9, Bit Rate Register (SCBRR).

Bit 1: CKS1	Bit 0: CKS0	Description	
0	0	$P\phi$	(Initial value)
	1	$P\phi/4$	
1	0	$P\phi/16$	
	1	$P\phi/64$	

Note: $P\phi$: Peripheral clock

14.2.6 Serial Control Register (SCSCR)

The serial control register (SCSCR) operates the SCI transmitter/receiver, selects the serial clock output in asynchronous mode, enables/disables interrupt requests, and selects the transmit/receive clock source. The CPU can always read and write to SCSCR. SCSCR is initialized to H'00 by a reset and in standby or module standby mode.

Bit:	7	6	5	4	3	2	1	0
	TIE	RIE	TE	RE	MPIE	TEIE	CKE1	CKE0
Initial value:	0	0	0	0	0	0	0	0
R/W:	R/W	R/W	R/W	R/W	R/W	R/W	R/W	R/W

Bit 7—Transmit Interrupt Enable (TIE): Enables or disables the transmit-data-empty interrupt (TXI) requested when the transmit data register empty bit (TDRE) in the serial status register (SCSSR) is set to 1 due to transfer of serial transmit data from SCTDR to SCTSR.

Bit 7: TIE	Description
0	Transmit-data-empty interrupt request (TXI) is disabled* (Initial value)
1	Transmit-data-empty interrupt request (TXI) is enabled

Note: * The TXI interrupt request can be cleared by reading TDRE after it has been set to 1, then clearing TDRE to 0, or by clearing TIE to 0.

Bit 6—Receive Interrupt Enable (RIE): Enables or disables the receive-data-full interrupt (RXI) requested when the receive data register full bit (RDRF) in the serial status register (SCSSR) is set to 1 due to transfer of serial receive data from SCRSR to SCRDR. It also enables or disables receive-error interrupt (ERI) requests.

Bit 6: RIE	Description
0	Receive-data-full interrupt (RXI) and receive-error interrupt (ERI) requests are disabled* (Initial value)
1	Receive-data-full interrupt (RXI) and receive-error interrupt (ERI) requests are enabled

Note: * RXI and ERI interrupt requests can be cleared by reading the RDRF flag or error flag (FER, PER, or ORER) after it has been set to 1, then clearing the flag to 0, or by clearing RIE to 0.

Bit 5—Transmit Enable (TE): Enables or disables the SCI serial transmitter.

Bit 5: TE	Description
0	Transmitter disabled* ¹ (Initial value)
1	Transmitter enabled* ²

- Notes:
1. The transmit data register empty bit (TDRE) in the serial status register (SCSSR) is fixed at 1.
 2. Serial transmission starts when the transmit data register empty (TDRE) bit in the serial status register (SCSSR) is cleared to 0 after writing of transmit data into the SCTDR. Select the transmit format in SCSMR before setting TE to 1.

Bit 4—Receive Enable (RE): Enables or disables the SCI serial receiver.

Bit 4: RE	Description
0	Receiver disabled* ¹ (Initial value)
1	Receiver enabled* ²

- Notes:
1. Clearing RE to 0 does not affect the receive flags (RDRF, FER, PER, ORER). These flags retain their previous values.
 2. Serial reception starts when a start bit is detected in asynchronous mode, or synchronous clock input is detected in synchronous mode. Select the receive format in SCSMR before setting RE to 1.

Bit 3—Multiprocessor Interrupt Enable (MPIE): Enables or disables multiprocessor interrupts. The MPIE setting is used only in asynchronous mode, and only if the multiprocessor mode bit (MP) in the serial mode register (SCSMR) is set to 1 during reception. The MPIE setting is ignored in synchronous mode or when the MP bit is cleared to 0.

Bit 3: MPIE	Description
0	Multiprocessor interrupts are disabled (normal receive operation) (Initial value) [Clearing conditions] (1) MPE is cleared to 0 when MPIE is cleared to 0. (2) The multiprocessor bit (MPB) is set to 1 in receive data.
1	Multiprocessor interrupts are enabled* Receive-data-full interrupt requests (RXI), receive-error interrupt requests (ERI), and setting of the RDRF, FER, and ORER status flags in the serial status register (SCSSR) are disabled until data with a multiprocessor bit of 1 is received.

- Note: * The SCI does not transfer receive data from SCRSR to SCRDR, does not detect receive errors, and does not set the RDRF, FER, and ORER flags in the serial status register (SCSSR). When it receives data that includes MPB = 1, the SCSSR's MPB flag is set to 1, and the SCI automatically clears MPIE to 0, generates RXI and ERI interrupts (if the TIE and RIE bits in the SCSMR are set to 1), and allows the FER and ORER bits to be set.

Bit 2—Transmit-End Interrupt Enable (TEIE): Enables or disables the transmit-end interrupt (TEI) requested if SCTDR does not contain new transmit data when the MSB is transmitted.

Bit 2: TEIE	Description
0	Transmit-end interrupt (TEI) requests are disabled* (Initial value)
1	Transmit-end interrupt (TEI) requests are enabled*

Note: * The TEI request can be cleared by reading the TDRE bit in the serial status register (SCSSR) after it has been set to 1, then clearing TDRE to 0 and clearing the transmit end (TEND) bit to 0, or by clearing the TEIE bit to 0.

Bits 1 and 0—Clock Enable 1 and 0 (CKE1, CKE0): Select the SCI clock source and enable or disable clock output from the SCK pin. Depending on the combination of CKE1 and CKE0, the SCK pin can be used for serial clock output or serial clock input.

The CKE0 setting is valid only in asynchronous mode, and only when the SCI is internally clocked (CKE1 = 0). The CKE0 setting is ignored in synchronous mode, or when an external clock source is selected (CKE1 = 1). Before selecting the SCI operating mode in the serial mode register (SCSMR), set CKE1 and CKE0. For further details on selection of the SCI clock source, see table 14.10 in section 14.3, Operation.

Bit 1: CKE1	Bit 0: CKE0	Description
0	0	Asynchronous mode Internal clock, SCK pin used for input pin (input signal is ignored) (Initial value)
		Synchronous mode Internal clock, SCK pin used for synchronous clock output (Initial value)
1	1	Asynchronous mode Internal clock, SCK pin used for clock output* ¹
		Synchronous mode Internal clock, SCK pin used for synchronous clock output
1	0	Asynchronous mode External clock, SCK pin used for clock input* ²
		Synchronous mode External clock, SCK pin used for synchronous clock input
1	1	Asynchronous mode External clock, SCK pin used for clock input* ²
		Synchronous mode External clock, SCK pin used for synchronous clock input

Notes: 1. The output clock frequency is the same as the bit rate.
2. The input clock frequency is 16 times the bit rate.

14.2.7 Serial Status Register (SCSSR)

The serial status register (SCSSR) is an 8-bit register containing multiprocessor bit values, and status flags that indicate the SCI operating state.

The CPU can always read and write to SCSSR, but cannot write 1 to the status flags (TDRE, RDRF, ORER, PER, and FER). These flags can be cleared to 0 only if they have first been read (after being set to 1). Bits 2 (TEND) and 1 (MPB) are read-only bits that cannot be written. SCSSR is initialized to H'84 by a reset and in standby or module standby mode.

Bit:	7	6	5	4	3	2	1	0
	TDRE	RDRF	ORER	FER	PER	TEND	MPB	MPBT
Initial value:	1	0	0	0	0	1	0	0
R/W:	R/(W)*	R/(W)*	R/(W)*	R/(W)*	R/(W)*	R	R	R/W

Note: * The only value that can be written is 0 to clear the flag.

Bit 7—Transmit Data Register Empty (TDRE): Indicates that the SCI has loaded transmit data from SCTDR into SCTSR and new serial transmit data can be written in SCTDR.

Bit 7: TDRE	Description
0	SCTDR contains valid transmit data [Clearing condition] TDRE is cleared to 0 when software reads TDRE after it has been set to 1.
1	SCTDR does not contain valid transmit data (Initial value) [Setting conditions] (1) TDRE is set to 1 when the chip is reset or enters standby mode. (2) The TE bit in the serial control register (SCSCR) is cleared to 0. (3) SCTDR contents are loaded into SCTSR, so new data can be written in SCTDR.

Bit 6—Receive Data Register Full (RDRF): Indicates that SCRDR contains received data.

Bit 6: RDRF	Description
0	SCRDR does not contain valid receive data (Initial value) [Clearing conditions] (1) RDRF is cleared to 0 when the chip is reset or enters standby mode. (2) Software reads RDRF after it has been set to 1, then writes 0 in RDRF.
1	SCRDR contains valid receive data [Setting condition] RDRF is set to 1 when serial data is received normally and transferred from SCRSR to SCRDR.

Note: SCRDR and RDRF are not affected by detection of receive errors or by clearing of the RE bit to 0 in the serial control register. They retain their previous contents. If RDRF is still set to 1 when reception of the next data ends, an overrun error (ORER) occurs and the receive data is lost.

Bit 5—Overrun Error (ORER): Indicates that data reception aborted due to an overrun error.

Bit 5: ORER	Description
0	Receiving is in progress or has ended normally* ¹ (Initial value) [Clearing conditions] (1) ORER is cleared to 0 when the chip is reset or enters standby mode. (2) When software reads ORER after it has been set to 1, then writes 0 to ORER.
1	A receive overrun error occurred* ² [Setting condition] ORER is set to 1 if reception of the next serial data ends when RDRF is set to 1.

Notes: 1. Clearing the RE bit to 0 in the serial control register does not affect the ORER bit, which retains its previous value.

2. SCRDR continues to hold the data received before the overrun error, so subsequent receive data is lost. Serial receiving cannot continue while ORER is set to 1. In synchronous mode, serial transmitting is also disabled.

Bit 4—Framing Error (FER): Indicates that data reception aborted due to a framing error in asynchronous mode.

Bit 4: FER	Description
0	Receiving is in progress or has ended normally* ¹ (Initial value) [Clearing conditions] (1) FER is cleared to 0 when the chip is reset or enters standby mode. (2) When software reads FER after it has been set to 1, then writes 0 to FER.
1	A receive framing error occurred [Setting condition] FER is set to 1 if the stop bit at the end of receive data is checked and found to be 0.* ²

- Notes:
1. Clearing the RE bit to 0 in the serial control register does not affect the FER bit, which retains its previous value.
 2. When the stop bit length is two bits, only the first bit is checked. The second stop bit is not checked. When a framing error occurs, the SCI transfers the receive data into SCRDR but does not set RDRF. Serial receiving cannot continue while FER is set to 1. In synchronous mode, serial transmitting is also disabled.

Bit 3—Parity Error (PER): Indicates that data reception (with parity) aborted due to a parity error in asynchronous mode.

Bit 3: PER	Description
0	Receiving is in progress or has ended normally* ¹ (Initial value) [Clearing conditions] (1) PER is cleared to 0 when the chip is reset or enters standby mode. (2) When software reads PER after it has been set to 1, then writes 0 to PER.
1	A receive parity error occurred* ² [Setting condition] PER is set to 1 if the number of 1s in receive data, including the parity bit, does not match the even or odd parity setting of the parity mode bit (O/ \bar{E}) in the serial mode register (SCSMR).

- Notes:
1. Clearing the RE bit to 0 in the serial control register does not affect the PER bit, which retains its previous value.
 2. When a parity error occurs, the SCI transfers the receive data into SCRDR but does not set RDRF. Serial receiving cannot continue while PER is set to 1. In synchronous mode, serial transmitting is also disabled.

Bit 2—Transmit End (TEND): Indicates that when the last bit of a serial character was transmitted, SCTDR did not contain valid data, so transmission has ended. TEND is a read-only bit and cannot be written to.

Bit 2: TEND	Description
0	Transmission is in progress [Clearing condition] TEND is cleared to 0 when software reads TDRE after it has been set to 1, then writes 0 to TDRE.
1	End of transmission (Initial value) [Setting conditions] (1) TEND is set to 1 when the chip is reset or enters standby mode. (2) When TE is cleared to 0 in the serial control register (SCSCR). (3) If TDRE is 1 when the last bit of a one-byte serial character is transmitted.

Bit 1—Multiprocessor Bit (MPB): Stores the value of the multiprocessor bit in receive data when a multiprocessor format is selected for receiving in asynchronous mode. MPB is a read-only bit and cannot be written to.

Bit 1: MPB	Description
0	Multiprocessor bit value in receive data is 0* (Initial value)
1	Multiprocessor bit value in receive data is 1

Note: * If RE is cleared to 0 when a multiprocessor format is selected, MPB retains its previous value.

Bit 0—Multiprocessor Bit Transfer (MPBT): Stores the value of the multiprocessor bit added to transmit data when a multiprocessor format is selected for transmitting in asynchronous mode. The MPBT setting is ignored in synchronous mode, when a multiprocessor format is not selected, or when the SCI is not transmitting.

Bit 0: MPBT	Description
0	Multiprocessor bit value in transmit data is 0 (Initial value)
1	Multiprocessor bit value in transmit data is 1

14.2.8 SC Port Control Register (SCPCR)/SC Port Data Register (SCPDR)

The SC port control register (SCPCR) and SC port data register (SCPDR) control I/O and data for the port pins multiplexed with the serial communication interface (SCI) pins.

SCPCR settings are used to perform I/O control, to enable data written in SCPDR to be output to the TxD pin, and input data to be read from the RxD pin, and to control serial transmission/reception breaks.

It is also possible to read data on the SCK pin, and write output data.

SCPCR

Bit:	15	14	13	12	11	10	9	8	7	6	5	4	3	2	1	0
	SCP7MD1	SCP7MD0	SCP6MD1	SCP6MD0	SCP5MD1	SCP5MD0	SCP4MD1	SCP4MD0	SCP3MD1	SCP3MD0	SCP2MD1	SCP2MD0	SCP1MD1	SCP1MD0	SCP0MD1	SCP0MD0
Initial value:	1	0	1	0	1	0	0	0	1	0	0	0	1	0	0	0
R/W:	R/W	R/W	R/W	R/W	R/W	R/W	R/W	R/W	R/W	R/W	R/W	R/W	R/W	R/W	R/W	R/W

SCPDR

Bit:	7	6	5	4	3	2	1	0
	SCP7DT	SCP6DT	SCP5DT	SCP4DT	SCP3DT	SCP2DT	SCP1DT	SCP0DT
Initial value:	0	0	0	0	0	0	0	0
R/W:	R	R/W	R/W	R/W	R/W	R/W	R/W	R/W

SCI pin I/O and data control are performed by bits 3–0 of SCPCR and bits 1 and 0 of SCPDR.

SCPCR Bits 3 and 2—Serial Clock Port I/O (SCP1MD1, SCP1MD0): Specify serial port SCK pin I/O. When the SCK pin is actually used as a port I/O pin, clear the C/\bar{A} bit in SCSMR and bits CKE1 and CKE0 in SCSCR to 0.

Bit 3: SCP1MD1	Bit 2: SCP1MD0	Description
0	0	SCP1DT bit value is not output to SCK pin
0	1	SCP1DT bit value is output to SCK pin
1	0	SCK pin value is read from SCP1DT bit
1	1	(Initial values: 1 and 0)

SCPDR Bit 1—Serial Clock Port Data (SCP1DT): Specifies the serial port SCK pin I/O data. Input or output is specified by the SCP1MD1 and SCP1MD0 bits. In output mode, the value of the SCP1DT bit is output to the SCK pin.

Bit 1:

SCP1DT	Description
0	I/O data is low (Initial value)
1	I/O data is high

SCPCR Bits 1 and 0—Serial Port Break I/O (SCP0MD1, SCP0MD0): Specify the serial port TxD pin output condition. When the TxD pin is actually used as a port output pin and outputs the value set with the SCP0DT bit, clear the TE bit in SCSCR to 0.

Bit 1: SCP0MD1	Bit 0: SCP0MD0	Description
0	0	SCP0DT bit value is not output to TxD pin (Initial value)
0	1	SCP0DT bit value is output to TxD pin

SCPDR Bit 0—Serial Port Break Data (SCP0DT): Specifies the serial port RxD pin input data and TxD pin output data. The TxD pin output condition is specified by the SCP0MD1 and SCP0MD0 bits. When the TxD pin is set to output mode, the value of the SCP0DT bit is output to the TxD pin. The RxD pin value is read from the SCP0DT bit regardless of the values of the SCP0MD1 and SCP0MD0 bits, if RE in SCSCR is set to 1. The initial value of this bit after a power-on reset is undefined.

Bit 0:

SCP0DT	Description
0	I/O data is low (Initial value)
1	I/O data is high

Block diagrams of the SCI I/O port pins are shown in figures 14.2, 14.3, and 14.4.

14.2.9 Bit Rate Register (SCBRR)

The bit rate register (SCBRR) is an 8-bit register that, together with the baud rate generator clock source selected by the CKS1 and CKS0 bits in the serial mode register (SCSMR), determines the serial transmit/receive bit rate.

The CPU can always read and write to SCBRR. SCBRR is initialized to H'FF by a reset, and in module standby or standby mode. Each channel has independent baud rate generator control, so different values can be set in two channels.

Bit:	7	6	5	4	3	2	1	0
Initial value:	1	1	1	1	1	1	1	1
R/W:	R/W	R/W	R/W	R/W	R/W	R/W	R/W	R/W

The SCBRR setting is calculated as follows:

$$\text{Asynchronous mode: } N = \frac{P\phi}{64 \times 2^{2n-1} \times B} \times 10^6 - 1$$

$$\text{Synchronous mode: } N = \frac{P\phi}{8 \times 2^{2n-1} \times B} \times 10^6 - 1$$

B: Bit rate (bits/s)

N: SCBRR setting for baud rate generator ($0 \leq N \leq 255$)

P ϕ : Operating frequency for peripheral modules (MHz)

n: Baud rate generator clock source ($n = 0, 1, 2, 3$) (for the clock sources and values of n, see table 14.3.)

Table 14.3 SCSMR Settings

n	Clock Source	SCSMR Settings	
		CKS1	CKS0
0	P ϕ	0	0
1	P ϕ /4	0	1
2	P ϕ /16	1	0
3	P ϕ /64	1	1

Note: The bit rate error in asynchronous is given by the following formula:

$$\text{Error (\%)} = \left(\frac{P\phi \times 10^6}{(N + 1) \times B \times 64 \times 2^{2n-1}} \right) \times 100$$

Table 14.4 lists examples of SCBRR settings in asynchronous mode, and table 14.5 lists examples of SCBRR settings in synchronous mode.

Table 14.4 Bit Rates and SCBRR Settings in Asynchronous Mode

Bit Rate (bits/s)	P ϕ (MHz)								
	2			2.097152			2.4576		
	n	N	Error (%)	n	N	Error (%)	n	N	Error (%)
110	1	141	0.03	1	148	-0.04	1	174	-0.26
150	1	103	0.16	1	108	0.21	1	127	0.00
300	0	207	0.16	0	217	0.21	0	255	0.00
600	0	103	0.16	0	108	0.21	0	127	0.00
1200	0	51	0.16	0	54	-0.70	0	63	0.00
2400	0	25	0.16	0	26	1.14	0	31	0.00
4800	0	12	0.16	0	13	-2.48	0	15	0.00
9600	0	6	-6.99	0	6	-2.48	0	7	0.00
19200	0	2	8.51	0	2	13.78	0	3	0.00
31250	0	1	0.00	0	1	4.86	0	1	22.88
38400	0	1	-18.62	0	1	-14.67	0	1	0.00

Bit Rate (bits/s)	P ϕ (MHz)								
	3			3.6864			4		
	n	N	Error (%)	n	N	Error (%)	n	N	Error (%)
110	1	212	0.03	2	64	0.70	2	70	0.03
150	1	155	0.16	1	191	0.00	1	207	0.16
300	1	77	0.16	1	95	0.00	1	103	0.16
600	0	155	0.16	0	191	0.00	0	207	0.16
1200	0	77	0.16	0	95	0.00	0	103	0.16
2400	0	38	0.16	0	47	0.00	0	51	0.16
4800	0	19	-2.34	0	23	0.00	0	25	0.16
9600	0	9	-2.34	0	11	0.00	0	12	0.16
19200	0	4	-2.34	0	5	0.00	0	6	-6.99
31250	0	2	0.00	—	—	—	0	3	0.00
38400	—	—	—	0	2	0.00	0	2	8.51

Bit Rate (bits/s)	P ϕ (MHz)								
	4.9152			5			6		
	n	N	Error (%)	n	N	Error (%)	n	N	Error (%)
110	2	86	0.31	2	88	-0.25	2	106	-0.44
150	1	255	0.00	2	64	0.16	2	77	0.16
300	1	127	0.00	1	129	0.16	1	155	0.16
600	0	255	0.00	1	64	0.16	1	77	0.16
1200	0	127	0.00	0	129	0.16	0	155	0.16
2400	0	63	0.00	0	64	0.16	0	77	0.16
4800	0	31	0.00	0	32	-1.36	0	38	0.16
9600	0	15	0.00	0	15	1.73	0	19	-2.34
19200	0	7	0.00	0	7	1.73	0	9	-2.34
31250	0	4	-1.70	0	4	0.00	0	5	0.00
38400	0	3	0.00	0	3	1.73	0	4	-2.34

Bit Rate (bits/s)	P ϕ (MHz)								
	6.144			7.3728			8		
	n	N	Error (%)	n	N	Error (%)	n	N	Error (%)
110	2	108	0.08	2	130	-0.07	2	141	0.03
150	2	79	0.00	2	95	0.00	2	103	0.16
300	1	159	0.00	1	191	0.00	1	207	0.16
600	1	79	0.00	1	95	0.00	1	103	0.16
1200	0	159	0.00	0	191	0.00	0	207	0.16
2400	0	79	0.00	0	95	0.00	0	103	0.16
4800	0	39	0.00	0	47	0.00	0	51	0.16
9600	0	19	0.00	0	23	0.00	0	25	0.16
19200	0	9	0.00	0	11	0.00	0	12	0.16
31250	0	5	2.40	0	6	5.33	0	7	0.00
38400	0	4	0.00	0	5	0.00	0	6	-6.99

Bit Rate (bits/s)	P ϕ (MHz)											
	14.7456			16			19.6608			20		
	n	N	Error (%)	n	N	Error (%)	n	N	Error (%)	n	N	Error (%)
110	3	64	0.70	3	70	0.03	3	86	0.31	3	88	-0.25
150	2	191	0.00	2	207	0.16	2	255	0.00	3	64	0.16
300	2	95	0.00	2	103	0.16	2	127	0.00	2	129	0.16
600	1	191	0.00	1	207	0.16	1	255	0.00	2	64	0.16
1200	1	95	0.00	1	103	0.16	1	127	0.00	1	129	0.16
2400	0	191	0.00	0	207	0.16	0	255	0.00	1	64	0.16
4800	0	95	0.00	0	103	0.16	0	127	0.00	0	129	0.16
9600	0	47	0.00	0	51	0.16	0	63	0.00	0	64	0.16
19200	0	23	0.00	0	25	0.16	0	31	0.00	0	32	-1.36
31250	0	14	-1.70	0	15	0.00	0	19	-1.70	0	19	0.00
38400	0	11	0.00	0	12	0.16	0	15	0.00	0	15	1.73

Bit Rate (bits/s)	P ϕ (MHz)											
	24			24.576			28.7			30		
	n	N	Error (%)	n	N	Error (%)	n	N	Error (%)	n	N	Error (%)
110	3	106	-0.44	3	108	0.08	3	126	0.31	3	132	0.13
150	3	77	0.16	3	79	0.00	3	92	0.46	3	97	-0.35
300	2	155	0.16	2	159	0.00	2	186	-0.08	2	194	0.16
600	2	77	0.16	2	79	0.00	2	92	0.46	2	97	-0.35
1200	1	155	0.16	1	159	0.00	1	186	-0.08	1	194	0.16
2400	1	77	0.16	1	79	0.00	1	92	0.46	1	97	-0.35
4800	0	155	0.16	0	159	0.00	0	186	-0.08	0	194	-1.36
9600	0	77	0.16	0	79	0.00	0	92	0.46	0	97	-0.35
19200	0	38	0.16	0	39	0.00	0	46	-0.61	0	48	-0.35
31250	0	23	0.00	0	24	-1.70	0	28	-1.03	0	29	0.00
38400	0	19	-2.34	0	19	0.00	0	22	1.55	0	23	1.73

Table 14.5 Bit Rates and SCBRR Settings in Synchronous Mode

Bit Rate (bits/s)	P ϕ (MHz)									
	4		8		16		28.7		30	
	n	N	n	N	n	N	n	N	n	N
110	—	—	—	—	—	—	—	—	—	—
250	2	249	3	124	3	249	—	—	—	—
500	2	124	2	249	3	124	3	223	3	233
1k	1	249	2	124	2	249	3	111	3	116
2.5k	1	99	1	199	2	99	2	178	2	187
5k	0	199	1	99	1	199	2	89	2	93
10k	0	99	0	199	1	99	1	178	1	187
25k	0	39	0	79	0	159	1	71	1	74
50k	0	19	0	39	0	79	0	143	0	149
100k	0	9	0	19	0	39	0	71	0	74
250k	0	3	0	7	0	15	—	—	0	29
500k	0	1	0	3	0	7	—	—	0	14
1M	0	0*	0	1	0	3	—	—	—	—
2M			0	0*	0	1	—	—	—	—

Notes: Settings with an error of 1% or less are recommended.

Blank: No setting possible

—: Setting possible, but error occurs

*: Continuous transmit/receive operation not possible

Table 14.6 indicates the maximum bit rates in asynchronous mode when the baud rate generator is used. Tables 14.7 and 14.8 list the maximum rates for external clock input.

Table 14.6 Maximum Bit Rates for Various Frequencies with Baud Rate Generator (Asynchronous Mode)

P ϕ (MHz)	Maximum Bit Rate (bits/s)	Settings	
		n	N
2	62500	0	0
2.097152	65536	0	0
2.4576	76800	0	0
3	93750	0	0
3.6864	115200	0	0
4	125000	0	0
4.9152	153600	0	0
8	250000	0	0
9.8304	307200	0	0
12	375000	0	0
14.7456	460800	0	0
16	500000	0	0
19.6608	614400	0	0
20	625000	0	0
24	750000	0	0
24.576	768000	0	0
28.7	896875	0	0
30	937500	0	0

Table 14.7 Maximum Bit Rates with External Clock Input (Asynchronous Mode)

Pϕ (MHz)	External Input Clock (MHz)	Maximum Bit Rate (bits/s)
2	0.5000	31250
2.097152	0.5243	32768
2.4576	0.6144	38400
3	0.7500	46875
3.6864	0.9216	57600
4	1.0000	62500
4.9152	1.2288	76800
8	2.0000	125000
9.8304	2.4576	153600
12	3.0000	187500
14.7456	3.6864	230400
16	4.0000	250000
19.6608	4.9152	307200
20	5.0000	312500
24	6.0000	375000
24.576	6.1440	384000
28.7	7.1750	448436
30	7.5000	468750

Table 14.8 Maximum Bit Rates with External Clock Input (Synchronous Mode)

Pϕ (MHz)	External Input Clock (MHz)	Maximum Bit Rate (bits/s)
8	1.3333	1333333.3
16	2.6667	2666666.7
24	4.0000	4000000.0
28.7	4.7833	4783333.3
30	5.0000	5000000.0

14.3 Operation

14.3.1 Overview

For serial communication, the SCI has an asynchronous mode in which characters are synchronized individually, and a synchronous mode in which communication is synchronized with clock pulses. Asynchronous/synchronous mode and the transmission format are selected in the serial mode register (SCSMR), as shown in table 14.9. The SCI clock source is selected by the combination of the C/\bar{A} bit in the serial mode register (SCSMR) and the CKE1 and CKE0 bits in the serial control register (SCSCR), as shown in table 14.10.

Asynchronous Mode:

- Data length is selectable: 7 or 8 bits.
- Parity and multiprocessor bits are selectable. So is the stop bit length (1 or 2 bits). The combination of the preceding selections constitutes the communication format and character length.
- In receiving, it is possible to detect framing errors (FER), parity errors (PER), overrun errors (ORER) and breaks.
- An internal or external clock can be selected as the SCI clock source.
 - When an internal clock is selected, the SCI operates using the on-chip baud rate generator, and can output a serial clock signal with a frequency matching the bit rate.
 - When an external clock is selected, the external clock input must have a frequency 16 times the bit rate. (The on-chip baud rate generator is not used.)

Synchronous Mode:

- The transmission/reception format has a fixed 8-bit data length.
- In receiving, it is possible to detect overrun errors (ORER).
- An internal or external clock can be selected as the SCI clock source.
 - When an internal clock is selected, the SCI operates using the on-chip baud rate generator, and outputs a serial clock signal to external devices.
 - When an external clock is selected, the SCI operates on the input serial clock. The on-chip baud rate generator is not used.

Table 14.9 Serial Mode Register Settings and SCI Communication Formats

SCSMR Settings					SCI Communication Format								
Bit 7 C/A	Bit 6 CHR	Bit 5 PE	Bit 2 MP	Bit 3 STOP	Mode	Data Length	Parity Bit	Multipro- cessor Bit	Stop Bit Length				
0	0	0	0	0	Asynchronous	8-bit	Not set	Not set	1 bit				
				1					2 bits				
				0					1 bit				
		1	2 bits										
		1	0	0					Asynchronous	7-bit	Not set	Not set	1 bit
				1									2 bits
	0			1 bit									
	1	0	1	0	Asynchronous (multiprocessor format)	8-bit	Not set	Set	1 bit				
				1					2 bits				
				0					1 bit				
		1	*	0					Asynchronous	7-bit	Not set	Set	1 bit
				1									2 bits
0				1 bit									
1	*	*	*	*	Synchronous	8-bit	Not set	None					

Note: Asterisks (*) indicate don't care bits.

Table 14.10 SCSMR and SCSCR Settings and SCI Clock Source Selection

SCSMR	SCSCR Settings		SCI Transmit/Receive Clock			
Bit 7 C/A	Bit 1 CKE1	Bit 0 CKE0	Mode	Clock Source	SCK Pin Function	
0	0	0	Asynchronous mode	Internal	SCI does not use the SCK pin	
		1			Outputs a clock with frequency matching the bit rate	
	1	0	Synchronous mode	External	Inputs a clock with frequency 16 times the bit rate	
		1			Outputs the synchronous clock	
1	0	0	Synchronous mode	Internal	Outputs the synchronous clock	
		1			Inputs the synchronous clock	
	1	0	0	Synchronous mode	External	Inputs the synchronous clock
			1			Outputs the synchronous clock

14.3.2 Operation in Asynchronous Mode

In asynchronous mode, each transmitted or received character begins with a start bit and ends with a stop bit. Serial communication is synchronized one character at a time.

The transmitting and receiving sections of the SCI are independent, so full duplex communication is possible. The transmitter and receiver are both double buffered, so data can be written and read while transmitting and receiving are in progress, enabling continuous transmitting and receiving.

Figure 14.5 shows the general format of asynchronous serial communication. In asynchronous serial communication, the communication line is normally held in the mark (high) state. The SCI monitors the line and starts serial communication when the line goes to the space (low) state, indicating a start bit. One serial character consists of a start bit (low), data (LSB first; starting from the lowestest bit), parity bit (high or low), and stop bit (high), in that order.

When receiving in asynchronous mode, the SCI synchronizes at the falling edge of the start bit. The SCI samples each data bit on the eighth pulse of a clock with a frequency 16 times the bit rate. Receive data is latched at the center of each bit.

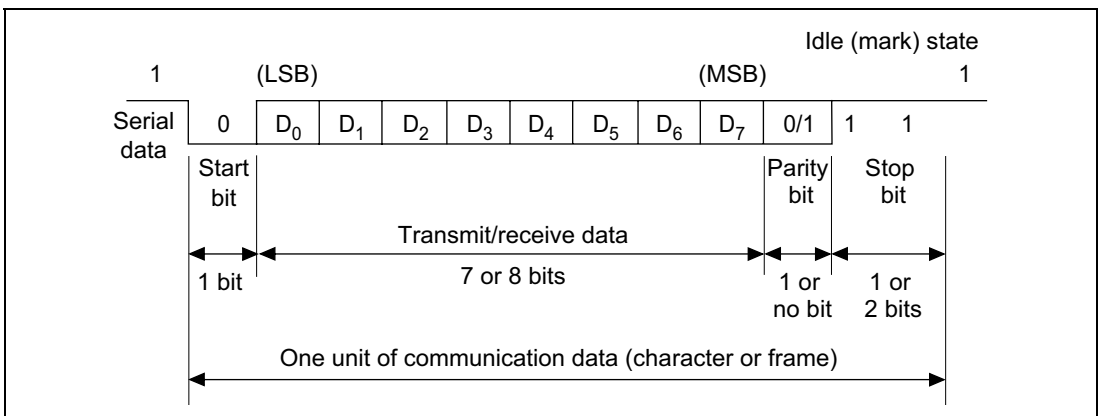

Figure 14.5 Example of Data Format in Asynchronous Communication (8-Bit Data with Parity and Two Stop Bits)

Transmit/Receive Formats: Table 14.11 lists the 12 communication formats that can be selected in asynchronous mode. The format is selected by settings in the serial mode register (SCSMR).

Table 14.11 Serial Communication Formats (Asynchronous Mode)

SCSMR Bits				Serial Transmit/Receive Format and Frame Length											
CHR	PE	MP	STOP	1	2	3	4	5	6	7	8	9	10	11	12
0	0	0	0	START	8-bit data								STOP		
0	0	0	1	START	8-bit data								STOP	STOP	
0	1	0	0	START	8-bit data								P	STOP	
0	1	0	1	START	8-bit data								P	STOP	STOP
1	0	0	0	START	7-bit data							STOP			
1	0	0	1	START	7-bit data							STOP	STOP		
1	1	0	0	START	7-bit data							P	STOP		
1	1	0	1	START	7-bit data							P	STOP	STOP	
0	—	1	0	START	8-bit data								MPB	STOP	
0	—	1	1	START	8-bit data								MPB	STOP	STOP
1	—	1	0	START	7-bit data							MPB	STOP		
1	—	1	1	START	7-bit data							MPB	STOP	STOP	

Notes: — : Don't care bits
 START: Start bit
 STOP: Stop bit
 P: Parity bit
 MPB: Multiprocessor bit

Clock: An internal clock generated by the on-chip baud rate generator or an external clock input from the SCK pin can be selected as the SCI transmit/receive clock. The clock source is selected by the $\overline{C/A}$ bit in the serial mode register (SCSMR) and bits CKE1 and CKE0 in the serial control register (SCSCR) (table 14.10).

When an external clock is input at the SCK pin, it must have a frequency equal to 16 times the desired bit rate.

When the SCI operates on an internal clock, it can output a clock signal at the SCK pin. The frequency of this output clock is equal to the bit rate. The phase is aligned as in figure 14.6 so that the rising edge of the clock occurs at the center of each transmit data bit.

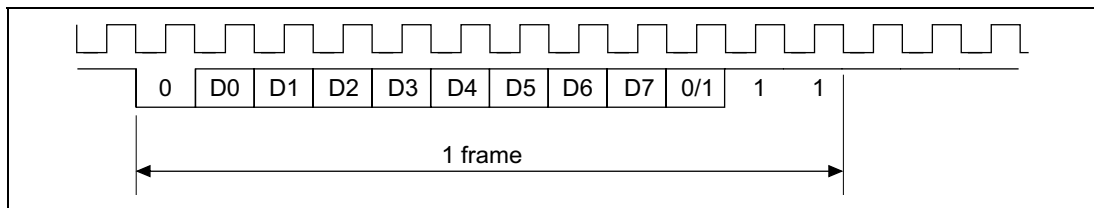

Figure 14.6 Output Clock and Serial Data Timing (Asynchronous Mode)

Transmitting and Receiving Data (SCI Initialization (Asynchronous Mode)): Before transmitting or receiving, clear the TE and RE bits to 0 in the serial control register (SCSCR), then initialize the SCI as follows.

When changing the operation mode or communication format, always clear the TE and RE bits to 0 before following the procedure given below. Clearing TE to 0 sets TDRE to 1 and initializes the transmit shift register (SCTSR). Clearing RE to 0, however, does not initialize the RDRF, PER, FER, and ORER flags or receive data register (SCRDR), which retain their previous contents.

When an external clock is used, the clock should not be stopped during initialization or subsequent operation. SCI operation becomes unreliable if the clock is stopped.

Figure 14.7 shows a sample flowchart for initializing the SCI. The procedure for initializing the SCI is:

1. Select the clock source in the serial control register (SCSCR). Leave RIE, TIE, TEIE, MPIE, TE, and RE cleared to 0. If clock output is selected in asynchronous mode, clock output starts immediately after the setting is made in SCSCR.
2. Select the communication format in the serial mode register (SCSMR).
3. Write the value corresponding to the bit rate in the bit rate register (SCBRR) (not necessary if an external clock is used).
4. Wait for at least the interval required to transmit or receive one bit, then set TE or RE in the serial control register (SCSCR) to 1. Also set RIE, TIE, TEIE, and MPIE as necessary. Setting TE or RE enables the SCI to use the TxD or RxD pin. The initial state is the mark state when transmitting, or the idle state (waiting for a start bit) when receiving.

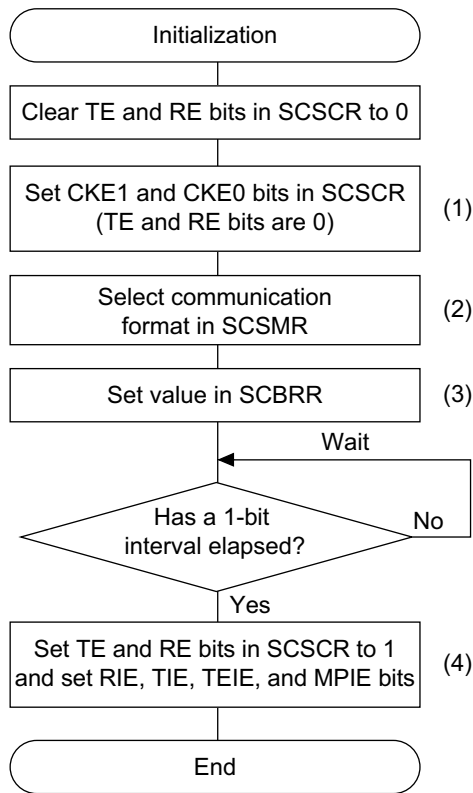

Note: Numbers in parentheses refer to steps in the preceding procedure description.

Figure 14.7 Sample Flowchart for SCI Initialization

Transmitting Serial Data (Asynchronous Mode): Figure 14.8 shows a sample flowchart for transmitting serial data. The procedure for transmitting serial data is:

1. SCI status check and transmit data write: Read the serial status register (SCSSR), check that the TDRE bit is 1, then write transmit data in the transmit data register (SCTDR) and clear TDRE to 0.
2. To continue transmitting serial data: Read the TDRE bit to check whether it is safe to write (if it reads 1); if so, write data in SCTDR, then clear TDRE to 0.
3. To output a break at the end of serial transmission: Set the port SC data register (SCPDR) and port SC control register (SCPCR), then clear the TE bit to 0 in the serial control register (SCSCR). For SCPCR and SCPDR settings, see section 14.2.8, SC Port Control Register (SCPCR)/SC Port Data Register (SCPDR).

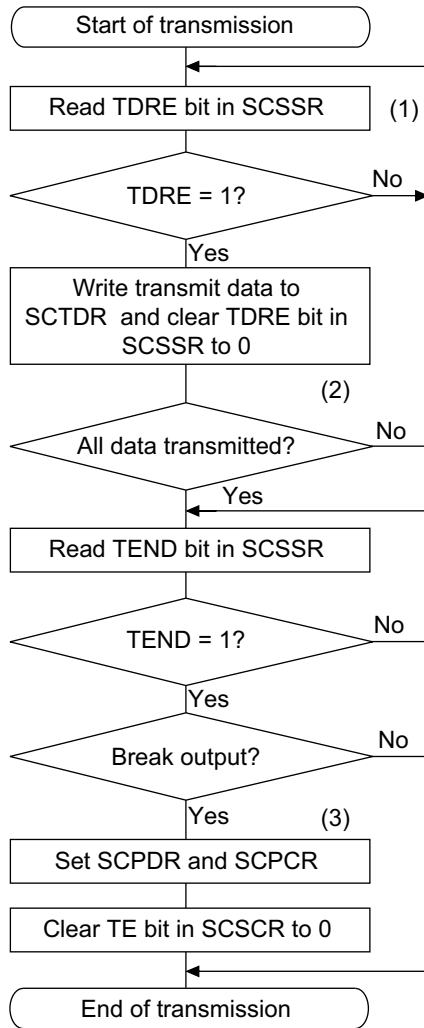

Note: Numbers in parentheses refer to steps in the preceding procedure description.

Figure 14.8 Sample Flowchart for Transmitting Serial Data

In transmitting serial data, the SCI operates as follows:

1. The SCI monitors the TDRE bit in SCSSR. When TDRE is cleared to 0, the SCI recognizes that the transmit data register (SCTDR) contains new data, and loads this data from SCTDR into the transmit shift register (SCTSR).
2. After loading the data from SCTDR into SCTSR, the SCI sets the TDRE bit to 1 and starts transmitting. If the transmit-data-empty interrupt enable bit (TIE) is set to 1 in SCSCR, the SCI requests a transmit-data-empty interrupt (TXI) at this time. Serial transmit data is transmitted in the following order from the TxD pin:
 - a. Start bit: One 0 bit is output.
 - b. Transmit data: Seven or eight bits of data are output, LSB first.
 - c. Parity bit or multiprocessor bit: One parity bit (even or odd parity) or one multiprocessor bit is output. Formats in which neither a parity bit nor a multiprocessor bit is output can also be selected.
 - d. Stop bit: One or two 1-bits (stop bits) are output.
 - e. Marking: Output of 1-bits continues until the start bit of the next transmit data.
3. The SCI checks the TDRE bit when it outputs the stop bit. If TDRE is 0, the SCI loads new data from SCTDR into SCTSR, outputs the stop bit, then begins serial transmission of the next frame. If TDRE is 1, the SCI sets the TEND bit to 1 in SCSSR, outputs the stop bit, then continues output of 1-bits (marking). If the transmit-end interrupt enable bit (TEIE) in SCSCR is set to 1, a transmit-end interrupt (TEI) is requested.

Figure 14.9 shows an example of SCI transmit operation in asynchronous mode.

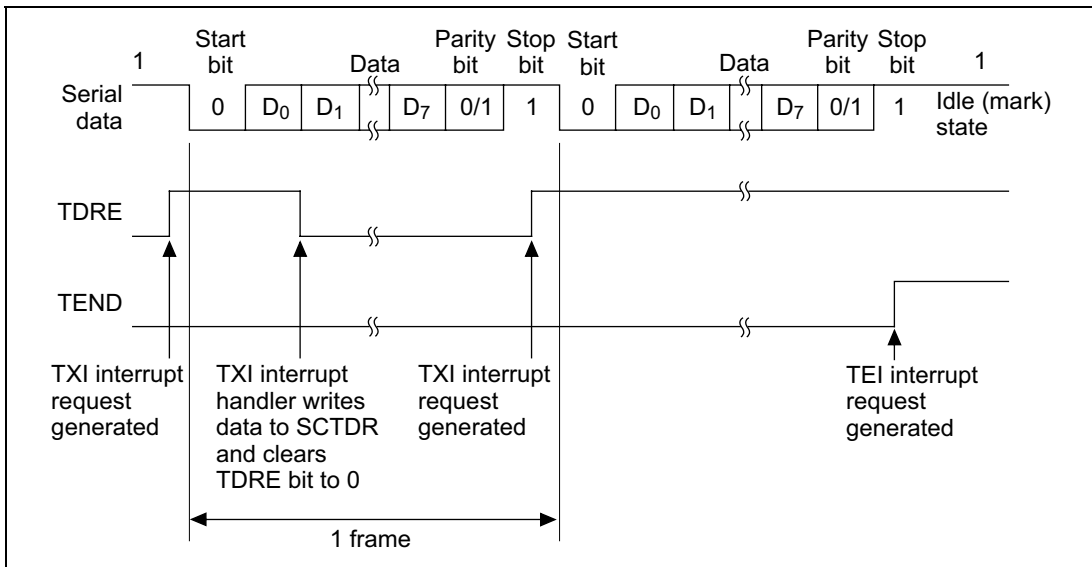
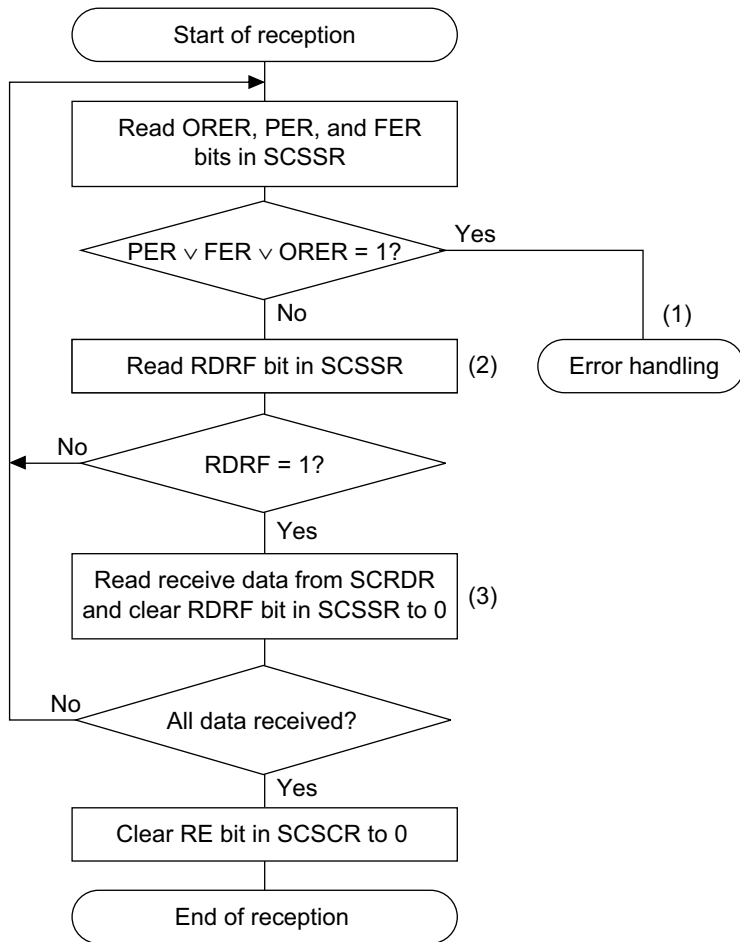

Figure 14.9 Example of SCI Transmit Operation in Asynchronous Mode (8-Bit Data with Parity and One Stop Bit)

Receiving Serial Data (Asynchronous Mode): Figure 14.10 shows a sample flowchart for receiving serial data. The procedure for receiving serial data after enabling the SCI for reception is:

1. Receive error handling and break detection: If a receive error occurs, read the ORER, PER and FER bits in SCSSR to identify the error. After executing the necessary error handling, clear ORER, PER and FER to 0. Receiving cannot resume if ORER, PER or FER remains set to 1. When a framing error occurs, the RxD pin can be read to detect the break state.
2. SCI status check and receive-data read: Read the serial status register (SCSSR), check that RDRF is set to 1, then read receive data from the receive data register (SCRDR) and clear RDRF to 0. The RXI interrupt can also be used to determine if the RDRF bit has changed from 0 to 1.
3. To continue receiving serial data: Read the RDRF and SCRDR bits and clear RDRF to 0 before the stop bit of the current frame is received.



Note: Numbers in parentheses refer to steps in the preceding procedure description.

Figure 14.10 Sample Flowchart for Receiving Serial Data

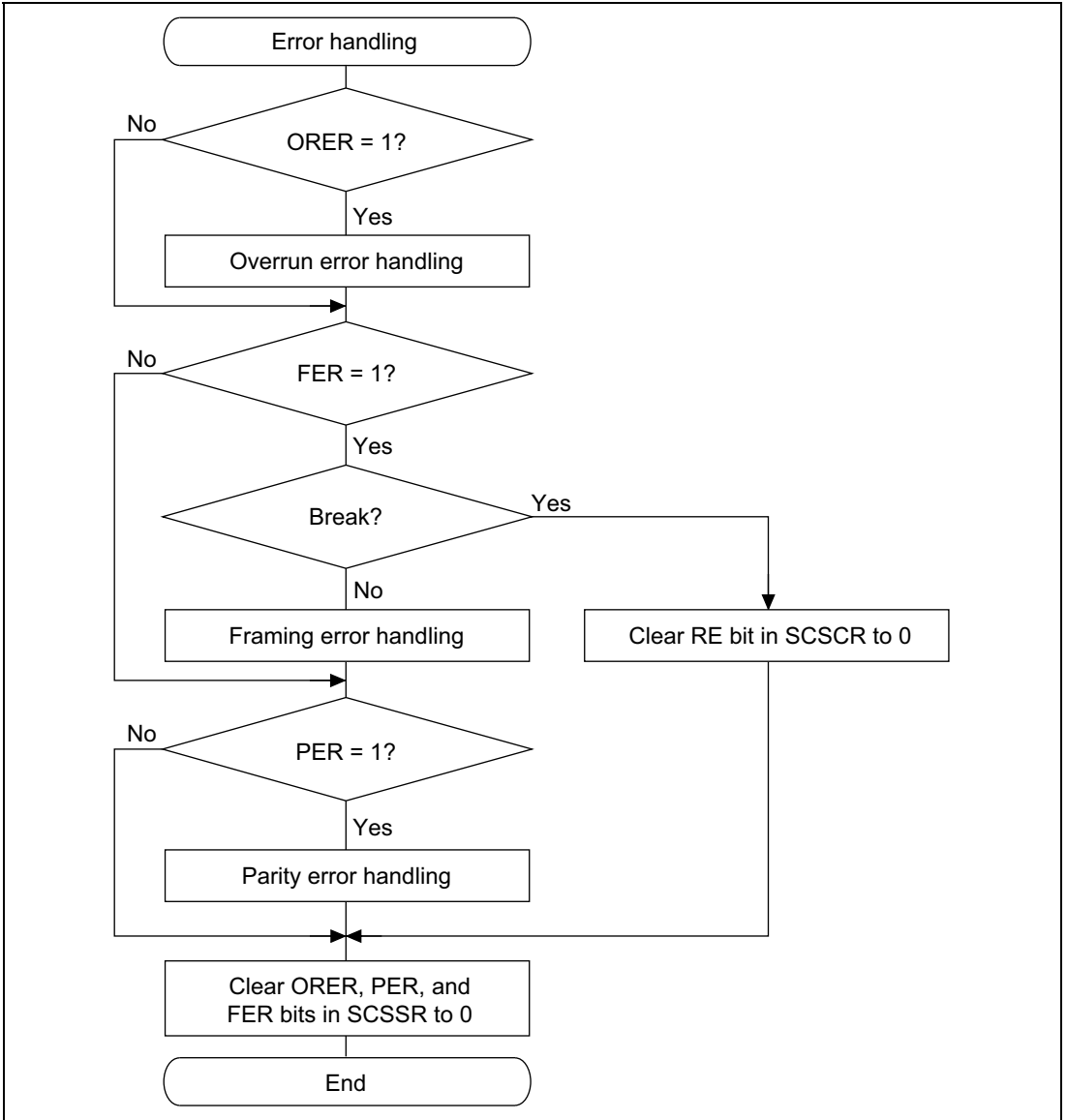

Figure 14.10 Sample Flowchart for Receiving Serial Data (cont)

In receiving, the SCI operates as follows:

1. The SCI monitors the communication line. When it detects a start bit (0), the SCI synchronizes internally and starts receiving.
2. Receive data is shifted into SCRSR in order from the LSB to the MSB.
3. The parity bit and stop bit are received. After receiving these bits, the SCI makes the following checks:
 - a. Parity check: The number of 1s in the receive data must match the even or odd parity setting of the O/ \bar{E} bit in SCSMR.
 - b. Stop bit check: The stop bit value must be 1. If there are two stop bits, only the first stop bit is checked.
 - c. Status check: RDRF must be 0 so that receive data can be loaded from SCRSR into SCRDR.

If these checks all pass, the SCI sets RDRF to 1 and stores the received data in SCRDR. If one of the checks fails (receive error), the SCI operates as indicated in table 14.12.

Note: When a receive error flag is set, further receiving is disabled. The RDRF bit is not set to 1. Be sure to clear the error flags.

4. After setting RDRF to 1, if the receive-data-full interrupt enable bit (RIE) is set to 1 in SCSCR, the SCI requests a receive-data-full interrupt (RXI). If one of the error flags (ORER, PER, or FER) is set to 1 and the receive-data-full interrupt enable bit (RIE) in SCSCR is also set to 1, the SCI requests a receive-error interrupt (ERI).

Table 14.12 Receive Error Conditions and SCI Operation

Receive Error	Abbreviation	Condition	Data Transfer
Overrun error	ORER	Receiving of next data ends while RDRF is still set to 1 in SCSSR	Receive data not transferred from SCRSR into SCRDR
Framing error	FER	Stop bit is 0	Receive data transferred from SCRSR into SCRDR
Parity error	PER	Parity of receive data differs from even/odd parity setting in SCSMR	Receive data transferred from SCRSR into SCRDR

Figure 14.11 shows an example of SCI receive operation in asynchronous mode.

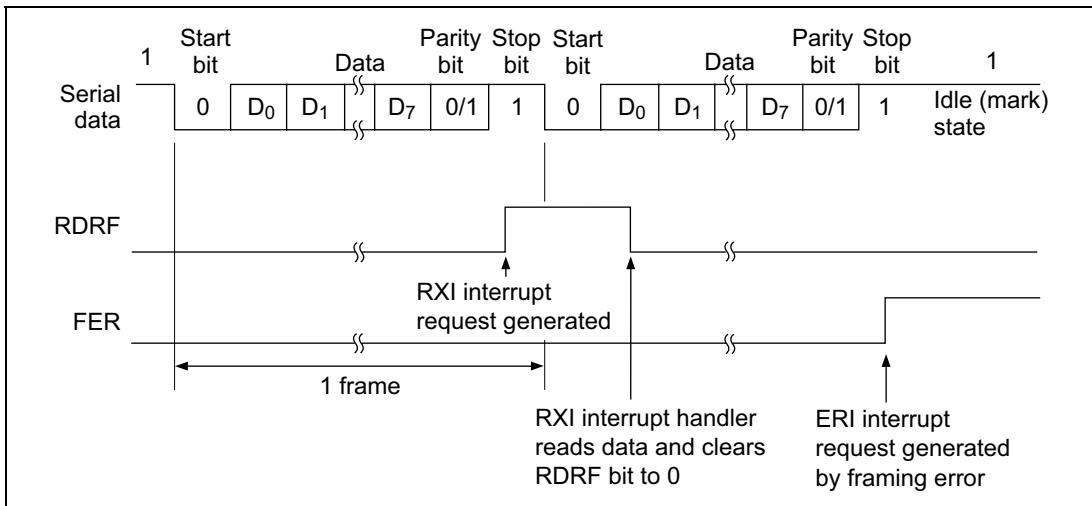

**Figure 14.11 Example of SCI Receive Operation
(8-Bit Data with Parity and One Stop Bit)**

14.3.3 Multiprocessor Communication

The multiprocessor communication function enables several processors to share a single serial communication line. The processors communicate in asynchronous mode using a format with an additional multiprocessor bit (multiprocessor format).

In multiprocessor communication, each receiving processor is addressed by a unique ID. A serial communication cycle consists of an ID-sending cycle that identifies the receiving processor, and a data-sending cycle. The multiprocessor bit distinguishes ID-sending cycles from data-sending cycles. The transmitting processor starts by sending the ID of the receiving processor with which it wants to communicate as data with the multiprocessor bit set to 1. Next the transmitting processor sends transmit data with the multiprocessor bit cleared to 0.

Receiving processors skip incoming data until they receive data with the multiprocessor bit set to 1. When they receive data with the multiprocessor bit set to 1, receiving processors compare the data with their IDs. The receiving processor with a matching ID continues to receive further incoming data. Processors with IDs not matching the received data skip further incoming data until they again receive data with the multiprocessor bit set to 1. Multiple processors can send and receive data in this way.

Figure 14.12 shows an example of communication among processors using the multiprocessor format.

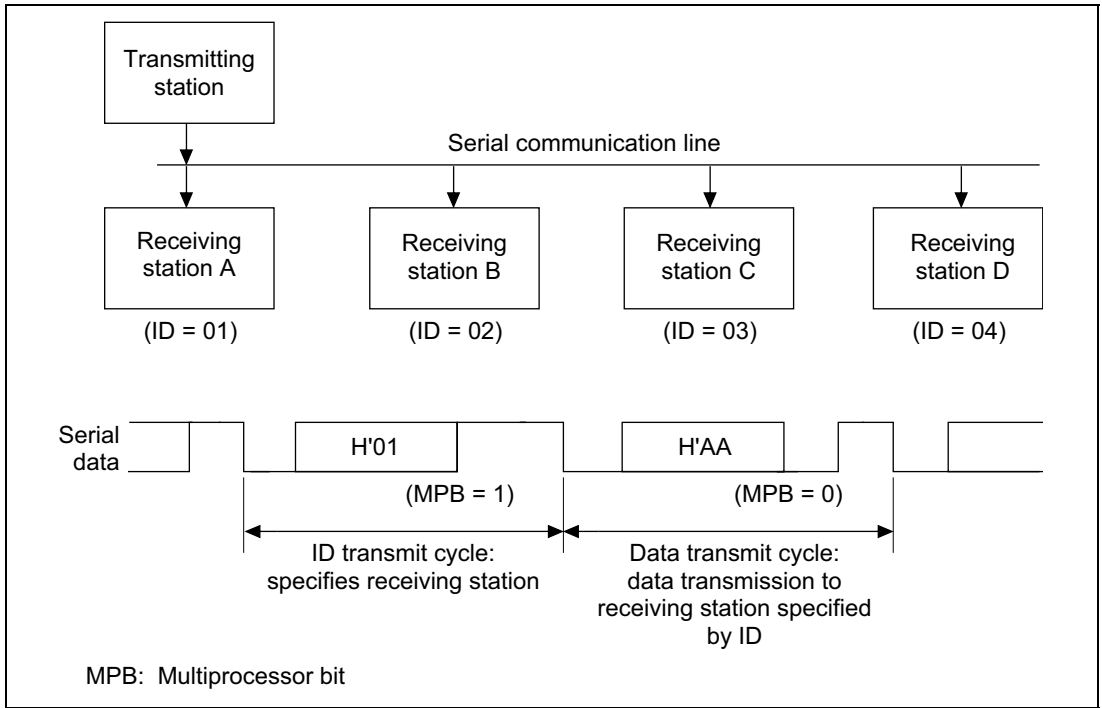

Figure 14.12 Communication Among Processors Using Multiprocessor Format (Sending Data H'AA to Receiving Processor A)

Communication Formats: Four formats are available. Parity-bit settings are ignored when the multiprocessor format is selected. For details see table 14.11.

Clock: See the description in the asynchronous mode section.

Transmitting Multiprocessor Serial Data: Figure 14.13 shows a sample flowchart for transmitting multiprocessor serial data. The procedure for transmitting multiprocessor serial data is:

1. **SCI status check and transmit data write:** Read the serial status register (SCSSR), check that the TDRE bit is 1, then write transmit data in the transmit data register (SCTDR). Also set MPBT (multiprocessor bit transfer) to 0 or 1 in SCSSR. Finally, clear TDRE to 0.
2. **To continue transmitting serial data:** Read the TDRE bit to check whether it is safe to write (if it reads 1); if so, write data in SCTDR, then clear TDRE to 0.
3. **To output a break at the end of serial transmission:** Set the port SC data register (SCPDR) and port SC control register (SCPCR), then clear the TE bit to 0 in the serial control register (SCSCR). For SCPCR and SCPDR settings, see section 14.2.8, SC Port Control Register (SCPCR)/SC Port Data Register (SCPDR).

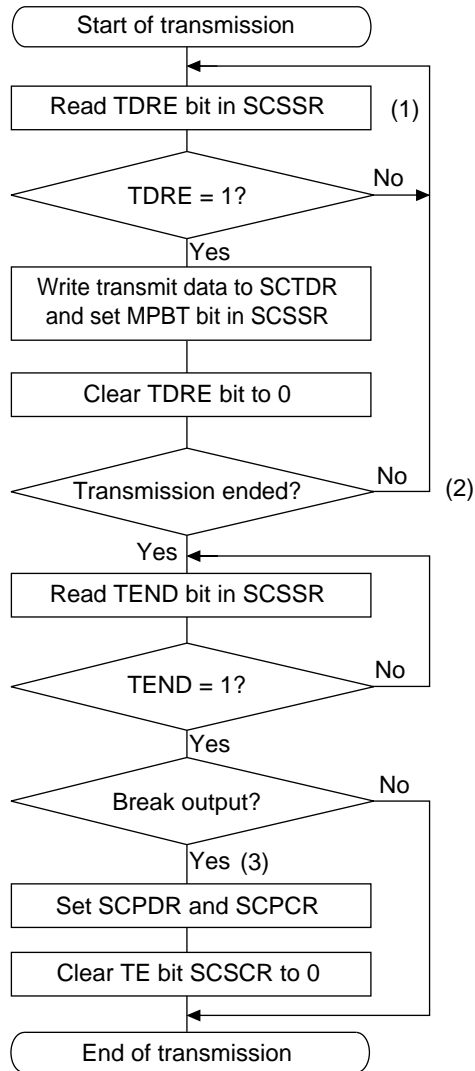

Note: Numbers in parentheses refer to steps in the preceding procedure description.

Figure 14.13 Sample Flowchart for Transmitting Multiprocessor Serial Data

In transmitting serial data, the SCI operates as follows:

1. The SCI monitors the TDRE bit in SCSSR. When TDRE is cleared to 0 the SCI recognizes that the transmit data register (SCTDR) contains new data, and transfers this data from SCTDR into the transmit shift register (SCTSR).
2. After loading the data from SCTDR into SCTSR, the SCI sets the TDRE bit to 1 and starts transmitting. If the transmit-data-empty interrupt enable bit (TIE) in SCSCR is set to 1, the SCI requests a transmit-data-empty interrupt (TXI) at this time. Serial transmit data is transmitted in the following order from the TxD pin:
 - a. Start bit: One 0-bit is output.
 - b. Transmit data: Seven or eight bits are output, LSB first.
 - c. Multiprocessor bit: One multiprocessor bit (MPBT value) is output.
 - d. Stop bit: One or two 1-bits (stop bits) are output.
 - e. Marking: Output of 1-bits continues until the start bit of the next transmit data.
3. The SCI checks the TDRE bit when it outputs the stop bit. If TDRE is 0, the SCI transfers data from SCTDR into SCTSR, outputs the stop bit, then begins serial transmission of the next frame. If TDRE is 1, the SCI sets the TEND bit in SCSSR to 1, outputs the stop bit, then continues output of 1 bits in the mark state. If the transmit-end interrupt enable bit (TEIE) in SCSCR is set to 1, a transmit-end interrupt (TEI) is requested at this time.

Figure 14.14 shows SCI transmission with a multiprocessor format.

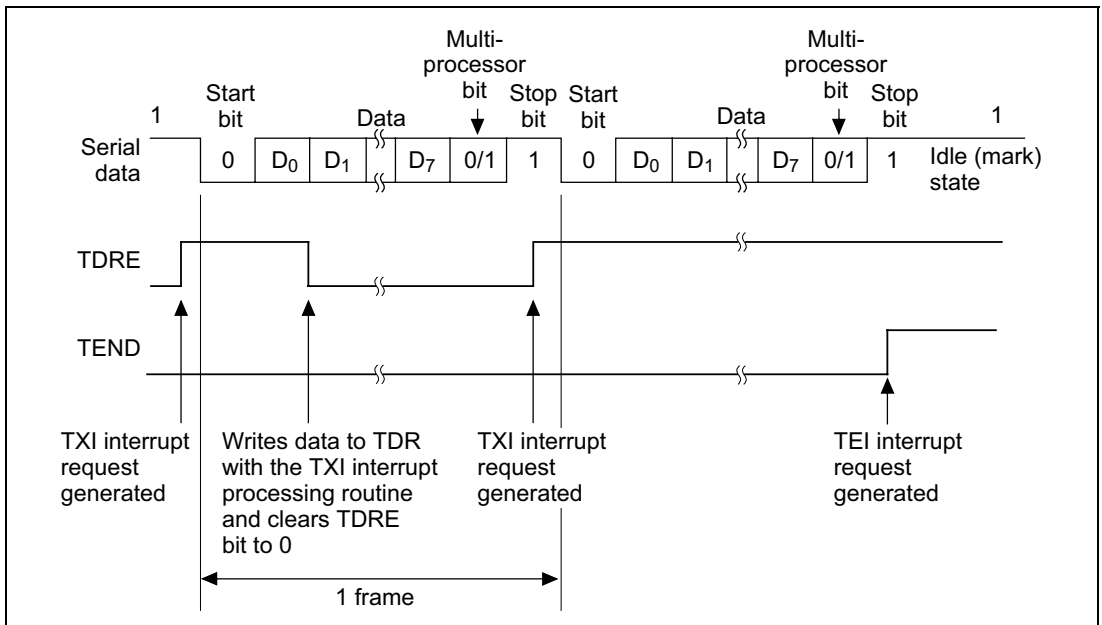

**Figure 14.14 Example of SCI Multiprocessor Transmit Operation
(8-Bit Data with Multiprocessor Bit and One Stop Bit)**

Receiving Multiprocessor Serial Data: Figure 14.15 shows a sample flowchart for receiving multiprocessor serial data. The procedure for receiving multiprocessor serial data is:

1. ID receive cycle: Set the MPIE bit in the serial control register (SCSCR) to 1.
2. SCI status check and compare to ID reception: Read the serial status register (SCSSR), check that RDRF is set to 1, then read data from the receive data register (SCRDR) and compare with the processor's own ID. If the ID does not match the receive data, set MPIE to 1 again and clear RDRF to 0. If the ID matches the receive data, clear RDRF to 0.
3. SCI status check and data receiving: Read SCSSR, check that RDRF is set to 1, then read data from the receive data register (SCRDR).
4. Receive error handling and break detection: If a receive error occurs, read the ORER and FER bits in SCSSR to identify the error. After executing the necessary error handling, clear both ORER and FER to 0. Receiving cannot resume if ORER or FER remain set to 1. When a framing error occurs, the RxD pin can be read to detect the break state.

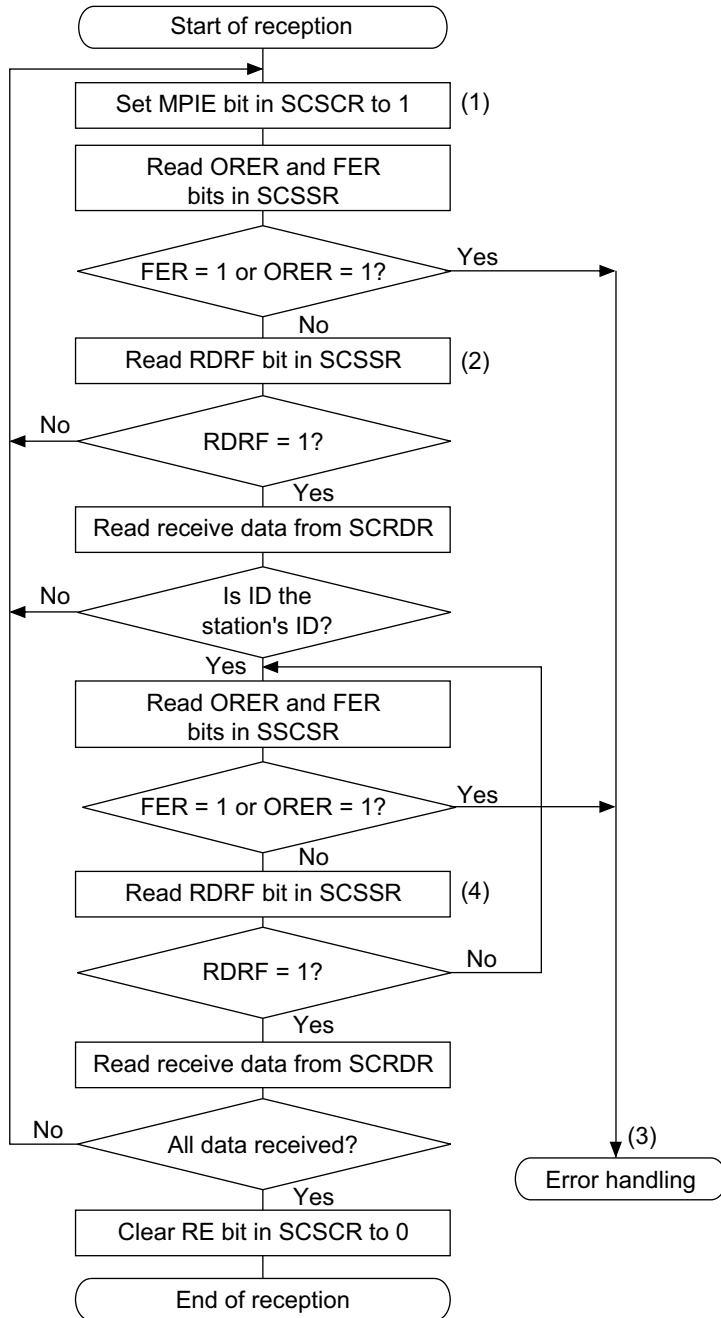

Note: Numbers in parentheses refer to steps in the preceding procedure description.

Figure 14.15 Sample Flowchart for Receiving Multiprocessor Serial Data

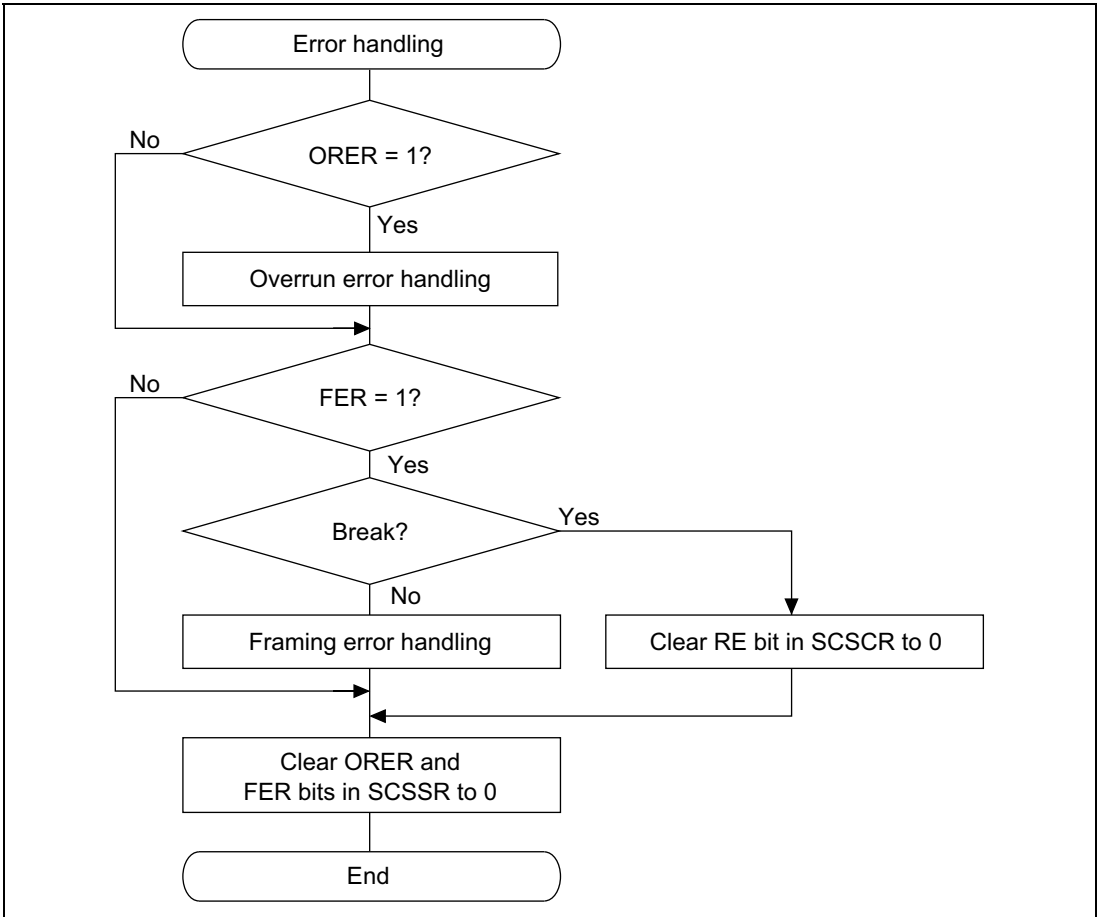
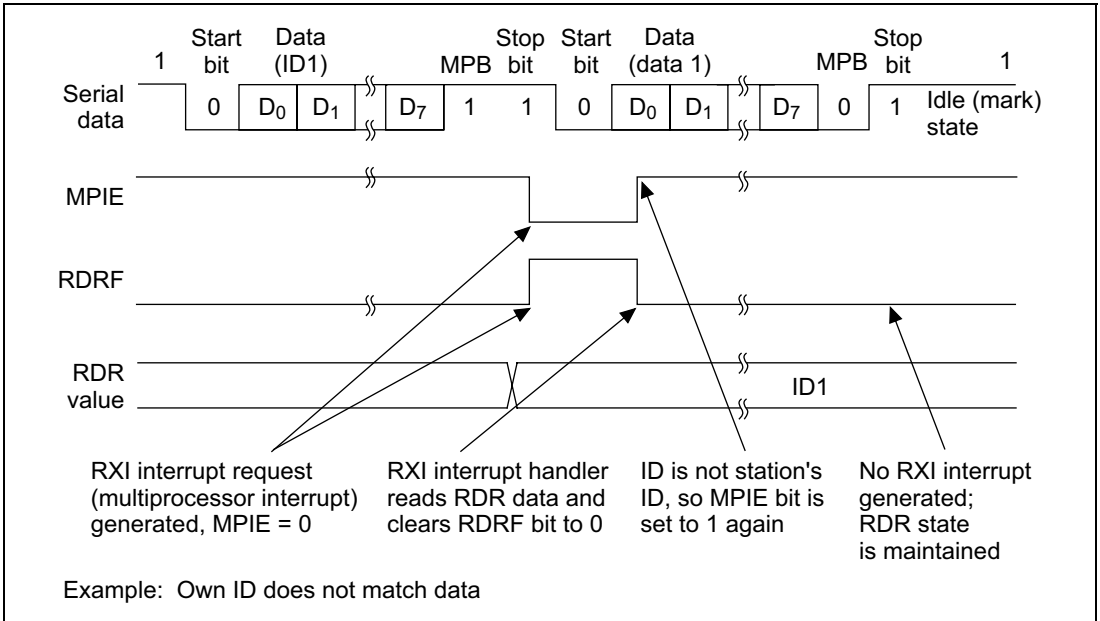
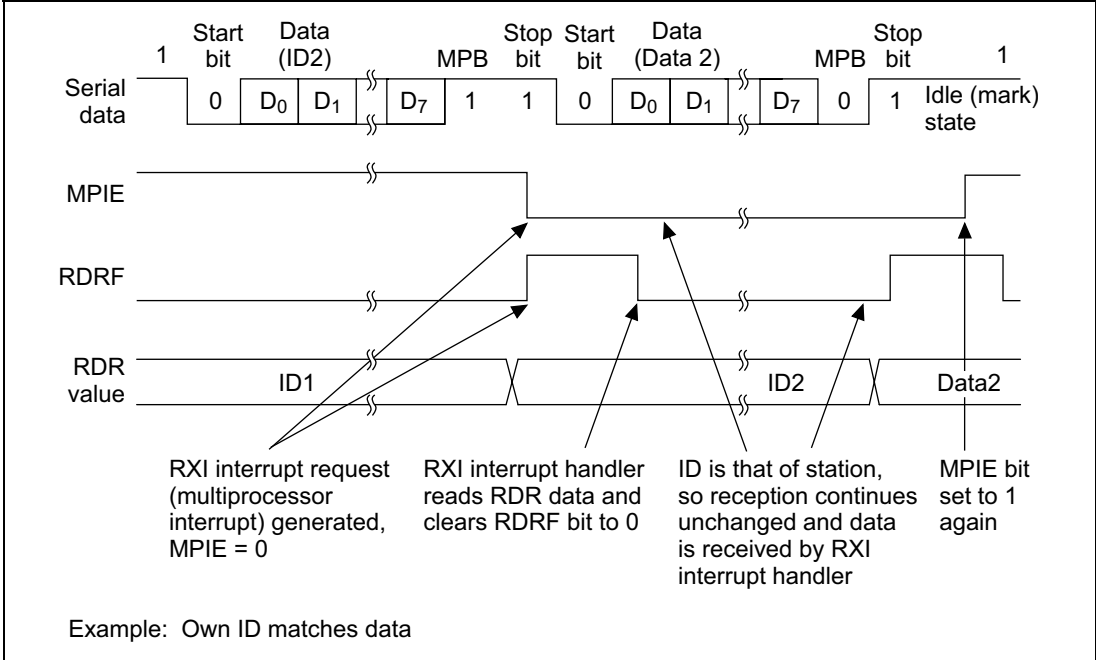

Figure 14.15 Sample Flowchart for Receiving Multiprocessor Serial Data (cont)

Figure 14.16 shows an example of SCI receive operation using a multiprocessor format.



**Figure 14.16 Example of SCI Receive Operation
(8-Bit Data with Multiprocessor Bit and One Stop Bit)**



**Figure 14.16 Example of SCI Receive Operation (cont)
(8-Bit Data with Multiprocessor Bit and One Stop Bit)**

14.3.4 Synchronous Operation

In synchronous mode, the SCI transmits and receives data in synchronization with clock pulses. This mode is suitable for high-speed serial communication.

The SCI transmitter and receiver are independent, so full-duplex communication is possible while sharing the same clock. The transmitter and receiver are also double buffered, so continuous transmitting or receiving is possible by reading or writing data while transmitting or receiving is in progress.

Figure 14.17 shows the general format in synchronous serial communication.

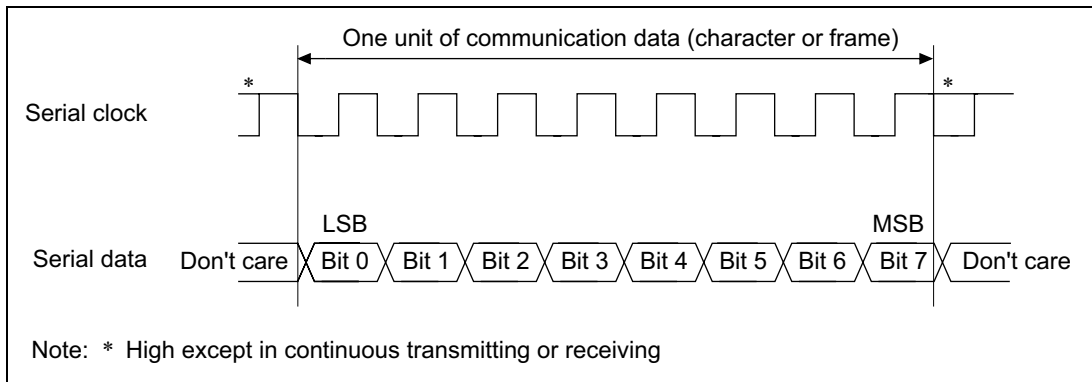

Figure 14.17 Data Format in Synchronous Communication

In synchronous serial communication, each data bit is output on the communication line from one falling edge of the serial clock to the next. Data is guaranteed valid at the rising edge of the serial clock. In each character, the serial data bits are transmitted in order from the LSB (first) to the MSB (last). After output of the MSB, the communication line remains in the state of the MSB. In synchronous mode, the SCI transmits or receives data by synchronizing with the falling edge of the serial clock.

Communication Format: The data length is fixed at eight bits. No parity bit or multiprocessor bit can be added.

Clock: An internal clock generated by the on-chip baud rate generator or an external clock input from the SCK pin can be selected as the SCI transmit/receive clock. The clock source is selected by the C/\overline{A} bit in the serial mode register (SCSMR) and bits CKE1 and CKE0 in the serial control register (SCSCR). See table 14.10.

When the SCI operates on an internal clock, it outputs the clock signal at the SCK pin. Eight clock pulses are output per transmitted or received character. When the SCI is not transmitting or receiving, the clock signal remains in the high state. When only receiving, the SCI receives in 2-character units, so a 16-pulse serial clock is output. To receive in 1-character units, select an external clock source.

Transmitting and Receiving Data SCI Initialization (Synchronous Mode): Before transmitting, receiving, or changing the mode or communication format, the software must clear the TE and RE bits to 0 in the serial control register (SCSCR), then initialize the SCI. Clearing TE to 0 sets TDRE to 1 and initializes the transmit shift register (SCTSR). Clearing RE to 0, however, does not initialize the RDRF, PER, FER, and ORER flags and receive data register (SCRDR), which retain their previous contents.

Figure 14.18 shows a sample flowchart for initializing the SCI. The procedure for initializing the SCI is:

1. Select the clock source in the serial control register (SCSCR). Leave RIE, TIE, TEIE, MPIE, TE and RE cleared to 0.
2. Select transmit/receive format in the serial mode register (SCSMR).
3. Write the value corresponding to the bit rate in the bit rate register (SCBRR) (not necessary if an external clock is used).
4. Wait for at least the interval required to transmit or receive one bit, then set TE or RE in the serial control register (SCSCR) to 1. Also set RIE, TIE, TEIE and MPIE. Setting TE and RE allows use of the TxD and RxD pins.

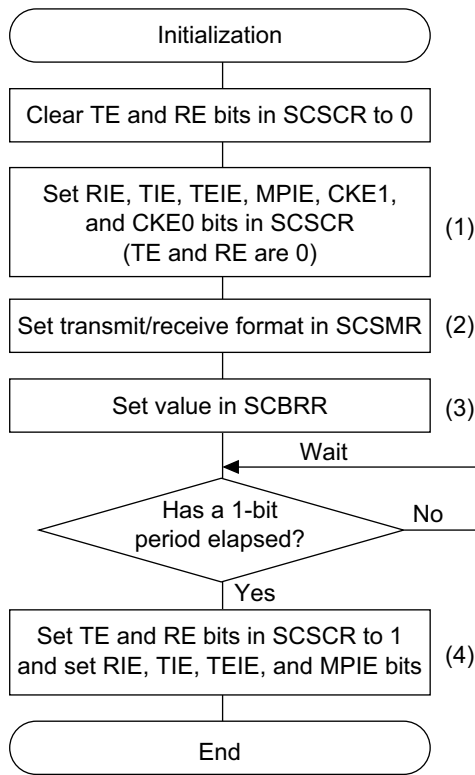

Note: Numbers in parentheses refer to steps in the preceding procedure description.

Figure 14.18 Sample Flowchart for SCI Initialization

Transmitting Serial Data (Synchronous Mode): Figure 14.19 shows a sample flowchart for transmitting serial data. The procedure for transmitting serial data is:

1. SCI status check and transmit data write: Read the serial status register (SCSSR), check that the TDRE bit is 1, then write transmit data in the transmit data register (SCTDR) and clear TDRE to 0.
2. To continue transmitting serial data: Read the TDRE bit to check whether it is safe to write (if it reads 1); if so, write data in SCTDR, then clear TDRE to 0.

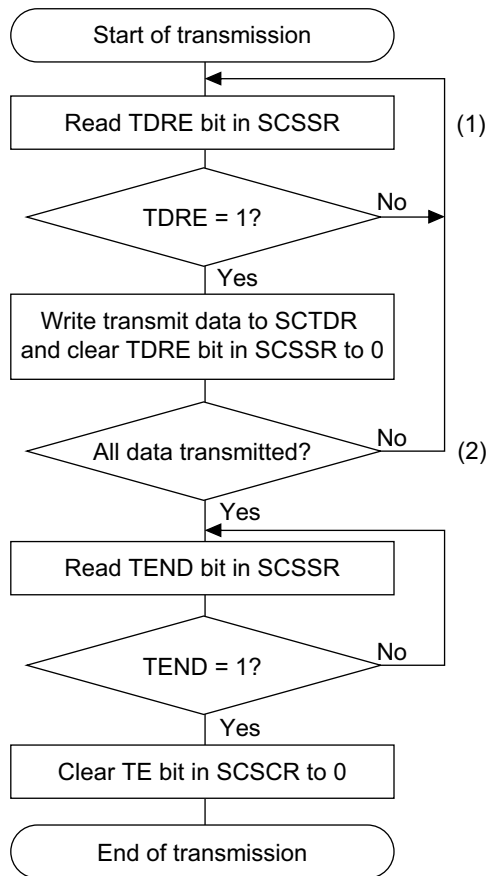

Note: Numbers in parentheses refer to steps in the preceding procedure description.

Figure 14.19 Sample Flowchart for Transmitting Serial Data

In transmitting serial data, the SCI operates as follows:

1. The SCI monitors the TDRE bit in SCSSR. When TDRE is cleared to 0 the SCI recognizes that the transmit data register (SCTDR) contains new data and loads this data from SCTDR into the transmit shift register (SCTSR).
2. After loading the data from SCTDR into SCTSR, the SCI sets the TDRE bit to 1 and starts transmitting. If the transmit-data-empty interrupt enable bit (TIE) in SCSCR is set to 1, the SCI requests a transmit-data-empty interrupt (TXI) at this time.

If clock output mode is selected, the SCI outputs eight synchronous clock pulses. If an external clock source is selected, the SCI outputs data in synchronization with the input clock. Data is output from the TxD pin in order from the LSB (bit 0) to the MSB (bit 7).

3. The SCI checks the TDRE bit when it outputs the MSB (bit 7). If TDRE is 0, the SCI loads data from SCTDR into SCTSR, then begins serial transmission of the next frame. If TDRE is 1, the SCI sets the TEND bit in SCSSR to 1, transmits the MSB, then holds the transmit data pin (TxD) in the MSB state. If the transmit-end interrupt enable bit (TEIE) in SCSCR is set to 1, a transmit-end interrupt (TEI) is requested at this time.
4. After the end of serial transmission, the SCK pin is held in the high state.

Figure 14.20 shows an example of SCI transmit operation.

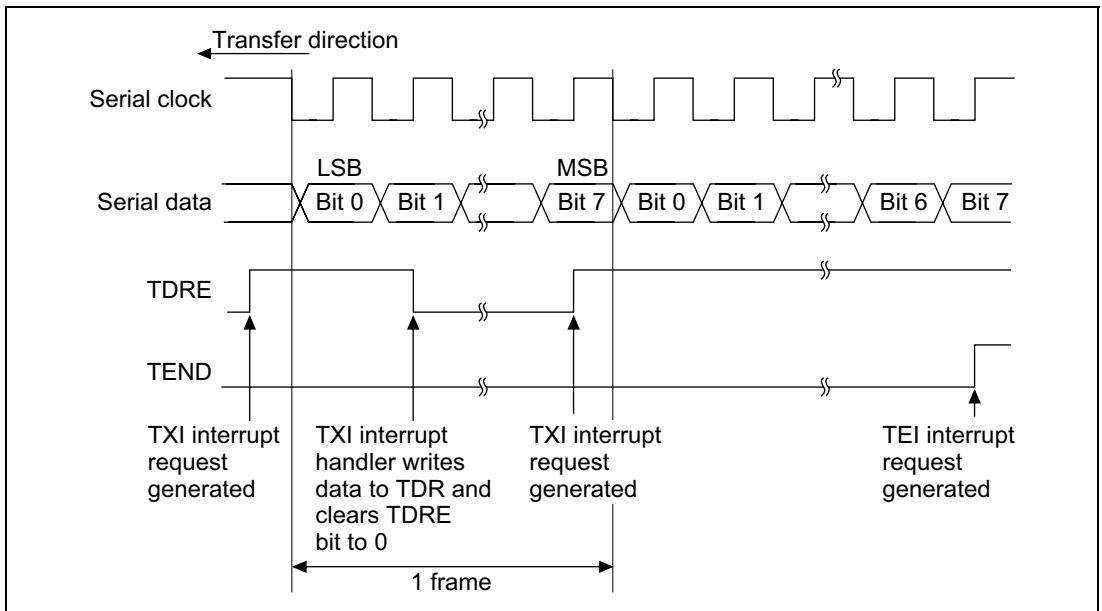
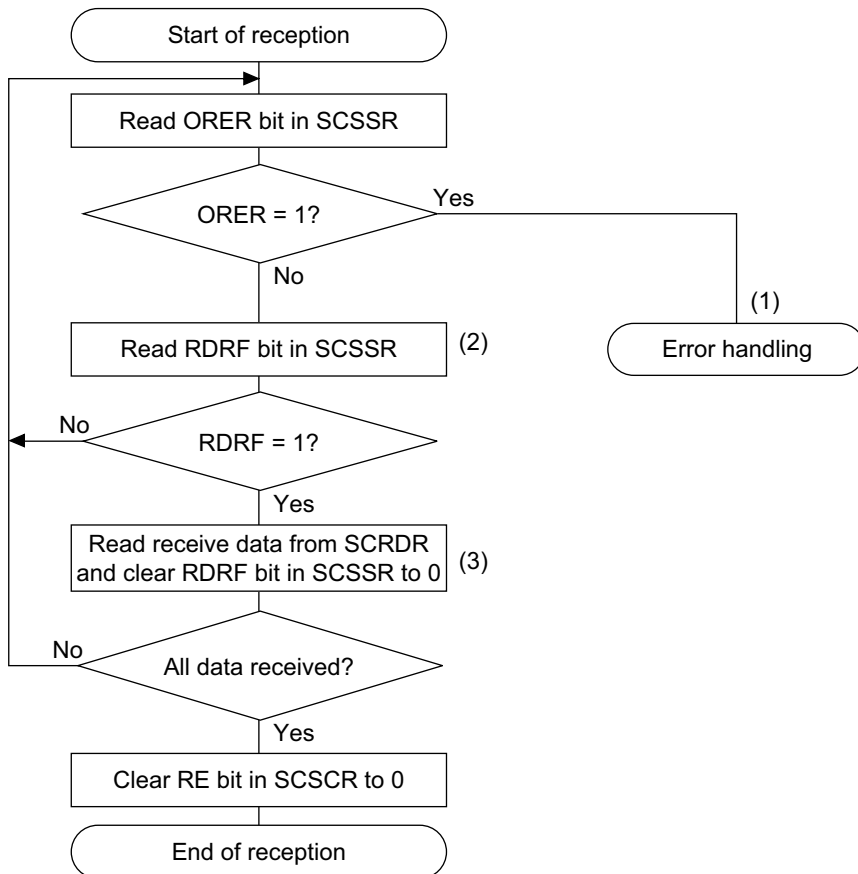

Figure 14.20 Example of SCI Transmit Operation

Receiving Serial Data (Synchronous Mode): Figure 14.21 shows a sample flowchart for receiving serial data. When switching from asynchronous mode to synchronous mode, make sure that ORER, PER, and FER are cleared to 0. If PER or FER is set to 1, the RDRF bit will not be set and both transmitting and receiving will be disabled.

The procedure for receiving serial data is:

1. Receive error handling: If a receive error occurs, read the ORER bit in SCSSR to identify the error. After executing the necessary error handling, clear ORER to 0. Transmitting/receiving cannot resume if ORER remains set to 1.
2. SCI status check and receive data read: Read the serial status register (SCSSR), check that RDRF is set to 1, then read receive data from the receive data register (SCRDR) and clear RDRF to 0. The RXI interrupt can also be used to determine if the RDRF bit has changed from 0 to 1.
3. To continue receiving serial data: Read SCRDR, and clear RDRF to 0 before the MSB (bit 7) of the current frame is received.



Note: Numbers in parentheses refer to steps in the preceding procedure description.

Figure 14.21 Sample Flowchart for Receiving Serial Data

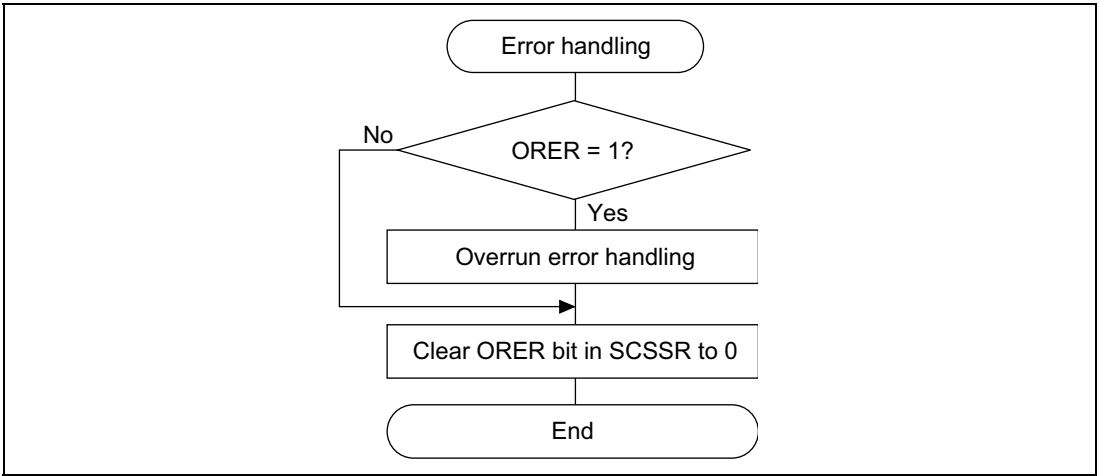

Figure 14.21 Sample Flowchart for Receiving Serial Data (cont)

In receiving, the SCI operates as follows:

1. The SCI synchronizes with serial clock input or output and initializes internally.
2. Receive data is shifted into SCRSR in order from the LSB to the MSB. After receiving the data, the SCI checks that RDRF is 0 so that receive data can be loaded from SCRSR into SCRDR. If this check is passed, the SCI sets RDRF to 1 and stores the received data in SCRDR. If the check is not passed (receive error), the SCI operates as indicated in table 14.12. This state prevents further transmission or reception. While receiving, the RDRF bit is not set to 1. Be sure to clear the error flag.
3. After setting RDRF to 1, if the receive-data-full interrupt enable bit (RIE) is set to 1 in SCSCR, the SCI requests a receive-data-full interrupt (RXI). If the ORER bit is set to 1 and the receive-data-full interrupt enable bit (RIE) in SCSCR is also set to 1, the SCI requests a receive-error interrupt (ERI).

Figure 14.22 shows an example of SCI receive operation.

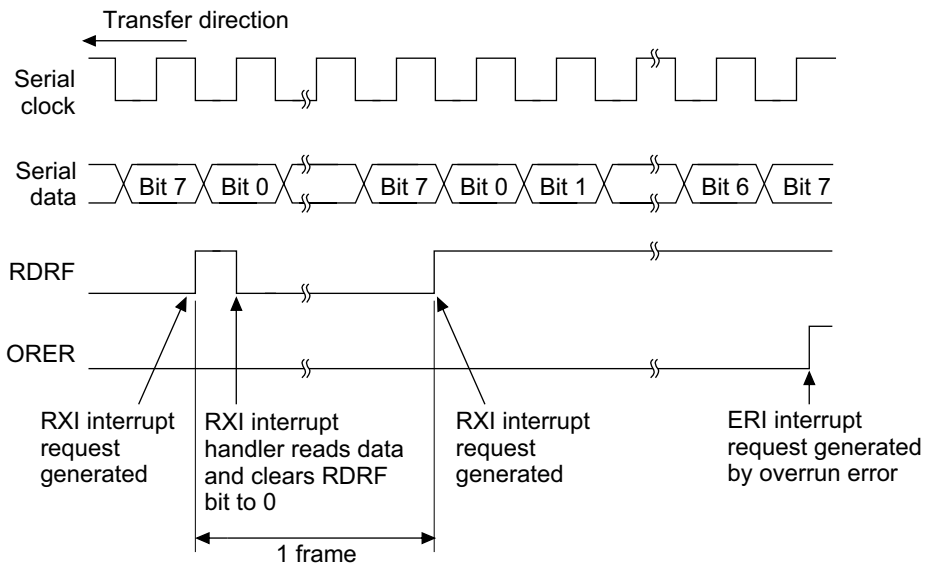
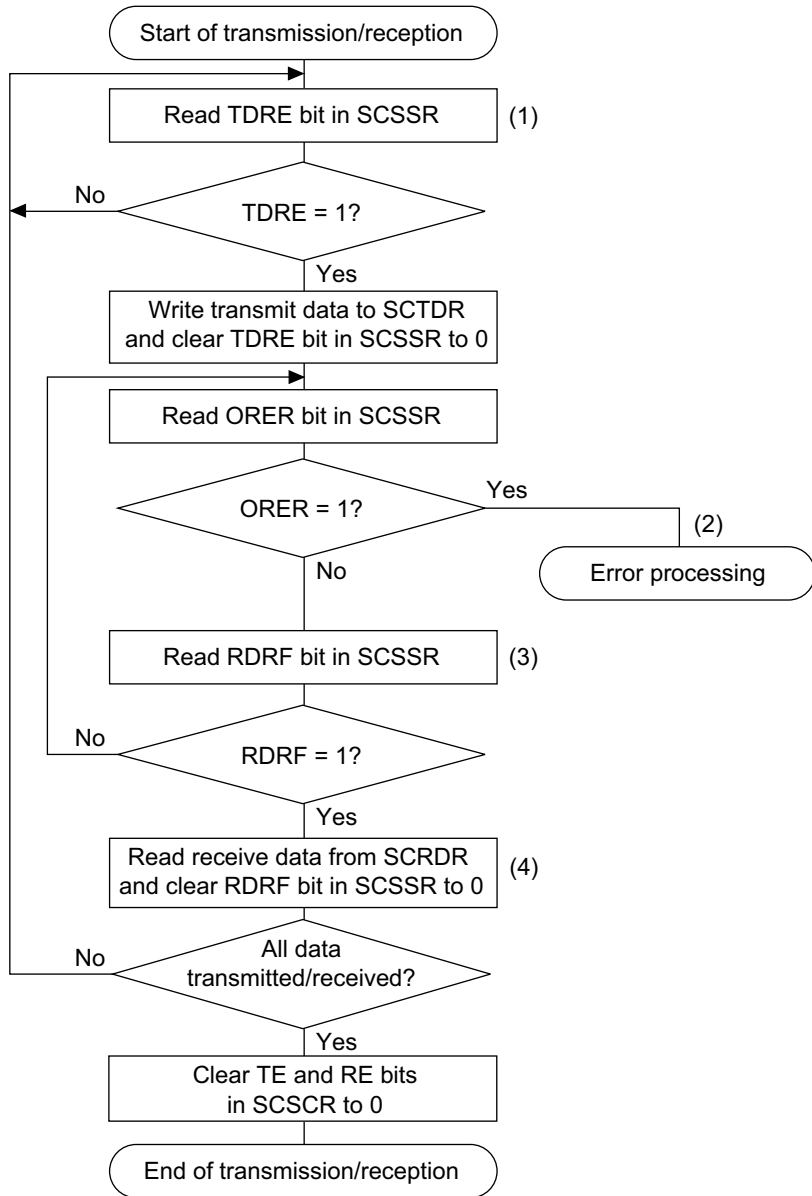

Figure 14.22 Example of SCI Receive Operation

Transmitting and Receiving Serial Data Simultaneously (Synchronous Mode): Figure 14.23 shows a sample flowchart for transmitting and receiving serial data simultaneously. The procedure for setting the SCI to transmit and receive serial data simultaneously is:

1. SCI status check and transmit data write: Read the serial status register (SCSSR), check that the TDRE bit is 1, then write transmit data in the transmit data register (SCTDR) and clear TDRE to 0. The TXI interrupt can also be used to determine if the TDRE bit has changed from 0 to 1.
2. Receive error handling: If a receive error occurs, read the ORER bit in SCSSR to identify the error. After executing the necessary error handling, clear ORER to 0. Transmitting/receiving cannot resume if ORER remains set to 1.
3. SCI status check and receive data read: Read the serial status register (SCSSR), check that RDRF is set to 1, then read receive data from the receive data register (SCRDR) and clear RDRF to 0. The RXI interrupt can also be used to determine if the RDRF bit has changed from 0 to 1.
4. To continue transmitting and receiving serial data: Read the RDRF bit and SCRDR, and clear RDRF to 0 before the MSB (bit 7) of the current frame is received. Also read the TDRE bit to check whether it is safe to write (if it reads 1); if so, write data in SCTDR, then clear TDRE to 0 before the MSB (bit 7) of the current frame is transmitted.



Notes: 1. Numbers in parentheses refer to steps in the preceding procedure description.

2. In switching from transmitting or receiving to simultaneous transmitting and receiving, clear both TE and RE to 0, then set both TE and RE to 1 simultaneously.

Figure 14.23 Sample Flowchart for Transmitting/Receiving Serial Data

14.4 SCI Interrupts

The SCI has four interrupt sources transmit-end (TEI), receive-error (ERI), receive-data-full (RXI), and transmit-data-empty (TXI). Table 14.13 lists the interrupt sources and indicates their priority. These interrupts can be enabled and disabled by the TIE, RIE, and TEIE bits in the serial control register (SCSCR). Each interrupt request is sent separately to the interrupt controller.

TXI is requested when the TDRE bit in SCSSR is set to 1.

RXI is requested when the RDRF bit in SCSSR is set to 1.

ERI is requested when the ORER, PER, or FER bit in SCSSR is set to 1.

TEI is requested when the TEND bit in SCSSR is set to 1. Where the TXI interrupt indicates that transmit data writing is enabled, the TEI interrupt indicates that the transmit operation is complete.

Table 14.13 SCI Interrupt Sources

Interrupt Source	Description	Priority When Reset Is Cleared
ERI	Receive error (ORER, PER, or FER)	High
RXI	Receive data full (RDRF)	↑
TXI	Transmit data empty (TDRE)	↓
TEI	Transmit end (TEND)	Low

See section 4, Exception Handling, for priorities and the relationship to non-SCI interrupts.

14.5 Usage Notes

Note the following points when using the SCI.

SCTDR Writing and TDRE Flag: The TDRE bit in the serial status register (SCSSR) is a status flag indicating loading of transmit data from SCTDR into SCTSRS. The SCI sets TDRE to 1 when it transfers data from SCTDR to SCTSRS. Data can be written to SCTDR regardless of the TDRE bit state. If new data is written in SCTDR when TDRE is 0, however, the old data stored in SCTDR will be lost because the data has not yet been transferred to SCTSRS. Before writing transmit data to SCTDR, be sure to check that TDRE is set to 1.

Simultaneous Multiple Receive Errors: Table 14.14 indicates the state of SCSSR status flags when multiple receive errors occur simultaneously. When an overrun error occurs, the SCRSR contents cannot be transferred to SCRDR, so receive data is lost.

Table 14.14 SCSSR Status Flags and Transfer of Receive Data

Receive Error Status	SCSSR Status Flags				Receive Data Transfer SCRSR → SCRDR
	RDRF	ORER	FER	PER	
Overrun error	1	1	0	0	X
Framing error	0	0	1	0	O
Parity error	0	0	0	1	O
Overrun error + framing error	1	1	1	0	X
Overrun error + parity error	1	1	0	1	X
Framing error + parity error	0	0	1	1	O
Overrun error + framing error + parity error	1	1	1	1	X

X: Receive data is not transferred from SCRSR to SCRDR.

O: Receive data is transferred from SCRSR to SCRDR.

Break Detection and Processing: Break signals can be detected by reading the RxD pin directly when a framing error (FER) is detected. In the break state, the input from the RxD pin consists of all 0s, so FER is set and the parity error flag (PER) may also be set. In the break state, the SCI receiver continues to operate, so if the FER bit is cleared to 0, it will be set to 1 again.

Sending a Break Signal: The TxD pin I/O condition and level can be determined by means of the SCP0DT bit in the port SC data register (SCPDR) and bits SCP0MD0 and SCP0MD1 in the port SC control register (SCPCR). This feature can be used to send breaks. To send a break during serial transmission, clear the SCP0DT bit to 0 (designating low level), then clear the TE bit to 0 (halting transmission). When the TE bit is cleared to 0, the transmitter is initialized regardless of the current transmission state, and 0 is output from the TxD pin.

TEND Flag and TE Bit Processing: The TEND flag is set to 1 during transmission of the stop bit of the last data. Consequently, if the TE bit is cleared to 0 immediately after setting of the TEND flag has been confirmed, the stop bit will be in the process of transmission and will not be transmitted normally. Therefore, the TE bit should not be cleared to 0 for at least 0.5 serial clock cycles (or 1.5 cycles if two stop bits are used) after setting of the TEND flag is confirmed.

Receive Error Flags and Transmitter Operation (Synchronous Mode Only): When a receive error flag (ORER, PER, or FER) is set to 1, the SCI will not start transmitting even if TDRE is set to 1. Be sure to clear the receive error flags to 0 before starting to transmit. Note that clearing RE to 0 does not clear the receive error flags.

Receive Data Sampling Timing and Receive Margin in Asynchronous Mode: In asynchronous mode, the SCI operates on a base clock of 16 times the transfer rate frequency. In receiving, the SCI synchronizes internally with the falling edge of the start bit, which it samples on the base clock. Receive data is latched at the rising edge of the eighth base clock pulse (figure 14.24).

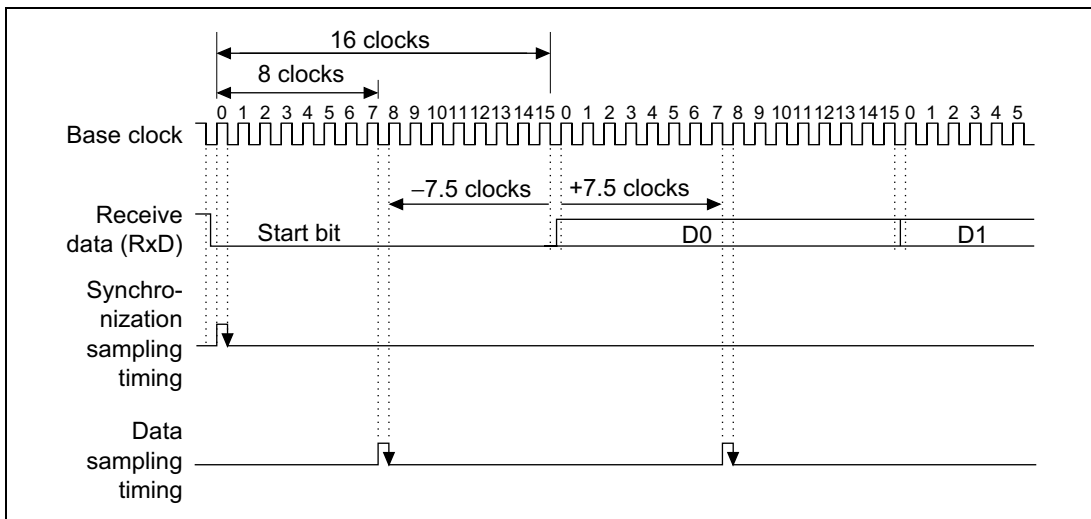

Figure 14.24 Receive Data Sampling Timing in Asynchronous Mode

The receive margin in asynchronous mode can therefore be expressed as in equation 1.

Equation 1:

$$M = \left| \left(0.5 - \frac{1}{2N} \right) - (L - 0.5)F - \frac{D - 0.5}{N} (1 + F) \right| \times 100\%$$

Where: M = Receive margin (%)

N = Ratio of clock frequency to bit rate (N = 16)

D = Clock duty cycle (D = 0 to 1.0)

L = Frame length (L = 9 to 12)

F = Absolute deviation of clock frequency

From equation 1, if F = 0 and D = 0.5, the receive margin is 46.875%, as in equation 2.

Equation 2:

$$\begin{aligned} M &= (0.5 - 1/(2 \times 16)) \times 100\% \\ &= 46.875\% \end{aligned}$$

This is a theoretical value. A reasonable margin to allow in system designs is 20% to 30%.

Notes on Synchronous External Clock Mode:

- Do not set TE = RE = 1 until at least four clocks after external clock SCK has changed from 0 to 1.
- Set TE = RE = 1 only when external clock SCK is 1.
- When receiving, RDRF is set to 1 when RE is set to zero 2.5–3.5 clocks after the rising edge of the SCK input of the D7 bit in RxD, but data cannot be copied to SCRDR.

Note on Synchronous Internal Clock Mode: When receiving, RDRF is set to 1 when RE is cleared to zero 1.5 clocks after the rising edge of the SCK output of the D7 bit in RxD, but data cannot be copied to SCRDR.

Section 15 Smart Card Interface

15.1 Overview

As an added serial communications interface function, the SCI supports an IC card (smart card) interface that conforms to the data transfer protocol (asynchronous half-duplex character transmission protocol) of the ISO/IEC7816-3 (Identification Card) standard. Register settings are used to switch between the normal serial communication interface and the smart card interface.

15.1.1 Features

The smart card interface has the following features:

- Asynchronous mode
 - Data length: 8 bits
 - Parity bit generation and check
 - Receive mode error signal detection (parity error)
 - Transmit mode error signal detection and automatic re-transmission of data
 - Supports both direct convention and inverse convention
- Bit rate can be selected using on-chip baud rate generator.
- Three types of interrupts: Transmit-data-empty, receive-data-full, and communication-error interrupts are requested independently.

15.1.2 Block Diagram

Figure 15.1 shows a block diagram of the smart card interface.

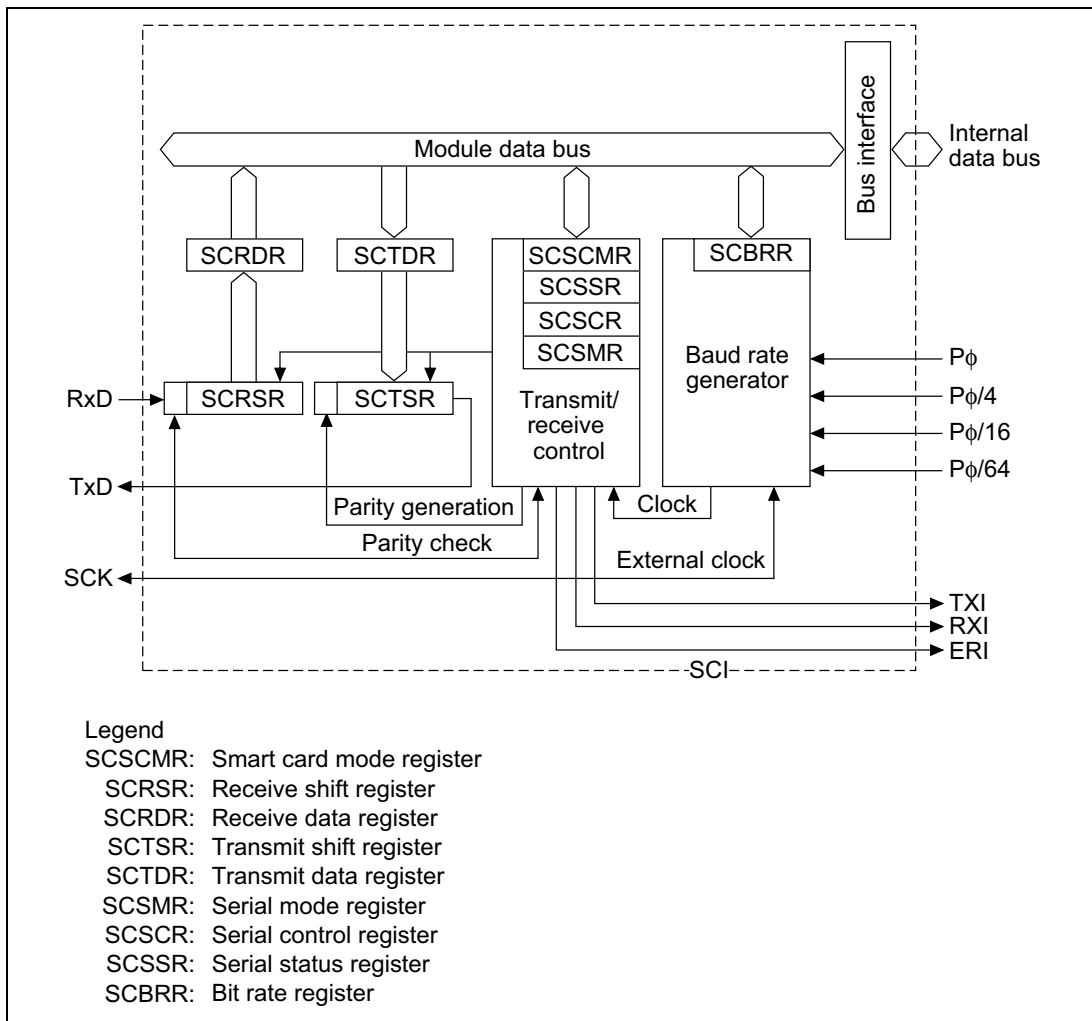

Figure 15.1 Block Diagram of Smart Card Interface

15.1.3 Pin Configuration

Table 15.1 summarizes the smart card interface pins.

Table 15.1 Smart Card Interface Pins

Pin Name	Abbreviation	I/O	Function
Serial clock pin	SCK0	Output	Clock output
Receive data pin	RxD0	Input	Receive data input
Transmit data pin	TxD0	Output	Transmit data output

15.1.4 Smart Card Interface Registers

Table 15.2 summarizes the registers used by the smart card interface. The SCSMR, SCBRR, SCSCR, SCTDR, and SCRDR registers are the same as for the normal SCI function. They are described in section 14, Serial Communication Interface (SCI).

Table 15.2 Registers

Name	Abbreviation	R/W	Initial Value ^{*3}	Address	Access Size
Serial mode register	SCSMR	R/W	H'00	H'FFFFFFE80	8
Bit rate register	SCBRR	R/W	H'FF	H'FFFFFFE82	8
Serial control register	SCSCR	R/W	H'00	H'FFFFFFE84	8
Transmit data register	SCTDR	R/W	H'FF	H'FFFFFFE86	8
Serial status register	SCSSR	R/(W) ^{*1}	H'84	H'FFFFFFE88	8
Receive data register	SCRDR	R	H'00	H'FFFFFFE8A	8
Smart card mode register	SCSCMR	R/W	H'00 ^{*2}	H'FFFFFFE8C	8

Notes: 1. Only 0 can be written, to clear the flags.

2. Bits 0, 2, and 3 are cleared. The value of the other bits is undefined.

3. Initialized by a power-on or manual reset.

15.2 Register Descriptions

This section describes the registers added for the smart card interface and the bits whose functions are changed.

15.2.1 Smart Card Mode Register (SCSCMR)

The smart card mode register (SCSCMR) is an 8-bit readable/writable register that selects smart card interface functions. SCSCMR bits 0, 2, and 3 are initialized to H'00 by a reset and in standby mode.

Bit:	7	6	5	4	3	2	1	0
	—	—	—	—	SDIR	SINV	—	SMIF
Initial value:	—	—	—	—	0	0	—	0
R/W:	R	R	R	R	R/W	R/W	R	R/W

Bits 7 to 4 and 1—Reserved: These bits are always read as 0. The write value should always be 0.

Bit 3—Smart Card Data Transfer Direction (SDIR): Selects the serial/parallel conversion format.

Bit 3: SDIR	Description
0	Contents of SCTDR are transferred LSB-first, and receive data is stored in SCRDR LSB-first (Initial value)
1	Contents of SCTDR are transferred MSB-first, and receive data is stored in SCRDR MSB-first

Bit 2—Smart Card Data Inversion (SINV): Specifies whether to invert the logic level of the data. This function is used in combination with bit 3 for transmitting and receiving with an inverse convention card. SINV does not affect the logic level of the parity bit. See section 15.3.4, Register Settings, for information on how parity is set.

Bit 2: SINV	Description
0	Contents of SCTDR are transferred unchanged, and receive data is stored in SCRDR unchanged (Initial value)
1	Contents of SCTDR are inverted before transfer, and receive data is inverted before storage in SCRDR

Bit 0—Smart Card Interface Mode Select (SMIF): Enables the smart card interface function.

Bit 0 : SMIF	Description
0	Smart card interface function disabled (Initial value)
1	Smart card interface function enabled

15.2.2 Serial Status Register (SCSSR)

In smart card interface mode, the function of SCSSR bit 4 is changed. The setting conditions for bit 2, the TEND bit, are also changed.

Bit:	7	6	5	4	3	2	1	0
	TDRE	RDRF	ORER	FER/ERS	PER	TEND	MPB	MPBT
Initial value:	1	0	0	0	0	1	0	0
R/W:	R/(W)*	R/(W)*	R/(W)*	R/(W)*	R/(W)*	R	R	R/W

Note: Only 0 can be written, to clear the flag.

Bit 7—Transmit Data Register Empty (TDRE)

Bit 6—Receive Data Register Full (RDRE)

Bit 5—Overrun Error (ORER)

These bits have the same function as in the ordinary SCI. See section 14, Serial Communication Interface (SCI), for more information.

Bit 4—Error Signal Status (ERS): In the smart card interface mode, bit 4 indicates the state of the error signal returned from the receiving side during transmission. The smart card interface cannot detect framing errors.

Bit 4: ERS	Description
0	Receiving ended normally with no error signal (Initial value) [Clearing conditions] (1) By a reset or in standby mode (2) Cleared by reading ERS when ERS = 1, then writing 0 to ERS
1	An error signal indicating a parity error was transmitted from the receiving side [Setting condition] If the error signal sampled is low

Note: The ERS flag maintains its state even when the TE bit in SCSCR is cleared to 0.

Bits 3 to 0: These bits have the same function as in the ordinary SCI. See section 14, Serial Communication Interface (SCI), for more information. The setting conditions for bit 2, the transmit end bit (TEND), are changed as follows.

Bit 2: TEND	Description
0	Transmission is in progress [Clearing condition] Cleared by reading TDRE when TDRE = 1, then writing 0 to TDRE
1	End of transmission (Initial value) [Setting conditions] (1) the chip is reset or enters standby mode, (2) the TE bit in SCSCR is 0 and the FER/ERS bit is also 0, (3) the C/ \bar{A} bit in SCSMR is 0, and TDRE = 1 and FER/ERS = 0 (normal transmission) 2.5 etu after a one-byte serial character is transmitted, or (4) the C/ \bar{A} bit in SCSMR is 1, and TDRE = 1 and FER/ERS = 0 (normal transmission) 1.0 etu after a one-byte serial character is transmitted.

Note: etu: Elementary Time Unit (time for transfer of 1 bit).

15.3 Operation

15.3.1 Overview

The primary functions of the smart card interface are described below.

1. Each frame consists of 8-bit data and 1 parity bit.
2. During transmission, the card leaves a guard time of at least 2 etu (elementary time units: time for transfer of 1 bit) from the end of the parity bit to the start of the next frame.
3. During reception, the card outputs an error signal low level for 1 etu after 10.5 etu has elapsed from the start bit if a parity error was detected.
4. During transmission, it automatically transmits the same data after allowing at least 2 etu from the time the error signal is sampled.
5. Only start-stop type asynchronous communication functions are supported; no synchronous communication functions are available.

15.3.2 Pin Connections

Figure 15.2 shows the pin connection diagram for the smart card interface. During communication with an IC card, transmission and reception are both carried out over the same data transfer line, so connect the TxD and RxD pins on the chip. Pull up the data transfer line to the power supply V_{CC} side with a register.

When using the clock generated by the smart card interface on an IC card, input the SCK pin output to the IC card's CLK pin. This connection is not necessary when the internal clock is used on the IC card.

Use the chip's port output as the reset signal. Apart from these pins, power and ground pin connections are usually also required.

Note: When the IC card is not connected and both RE and TE are set to 1, closed communication is possible and auto-diagnosis can be performed.

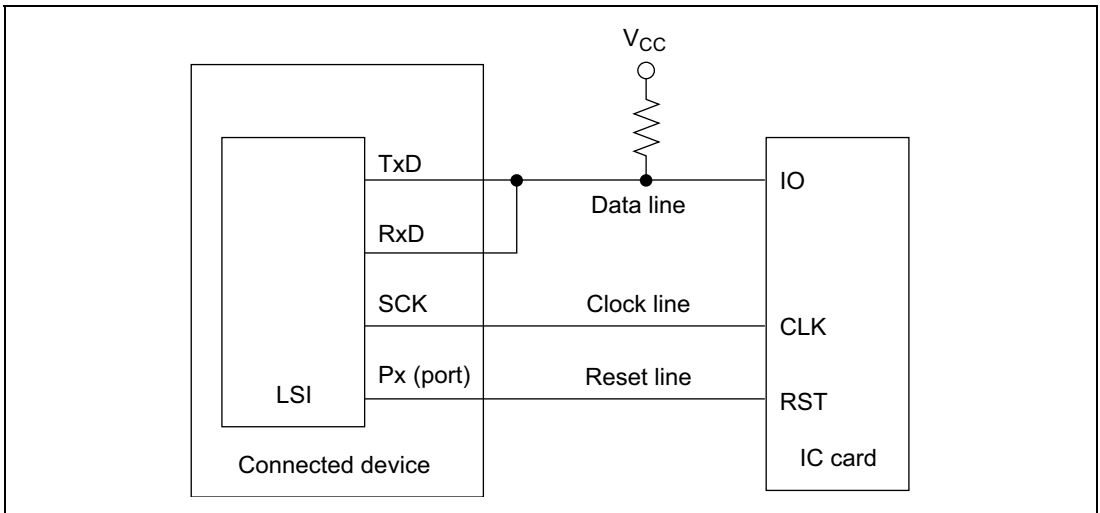

Figure 15.2 Pin Connection Diagram for Smart Card Interface

15.3.3 Data Format

Figure 15.3 shows the data format for the smart card interface. In this mode, parity is checked every frame while receiving and error signals sent to the transmitting side whenever an error is detected so that data can be re-transmitted. During transmission, error signals are sampled and data re-transmitted whenever an error signal is detected.

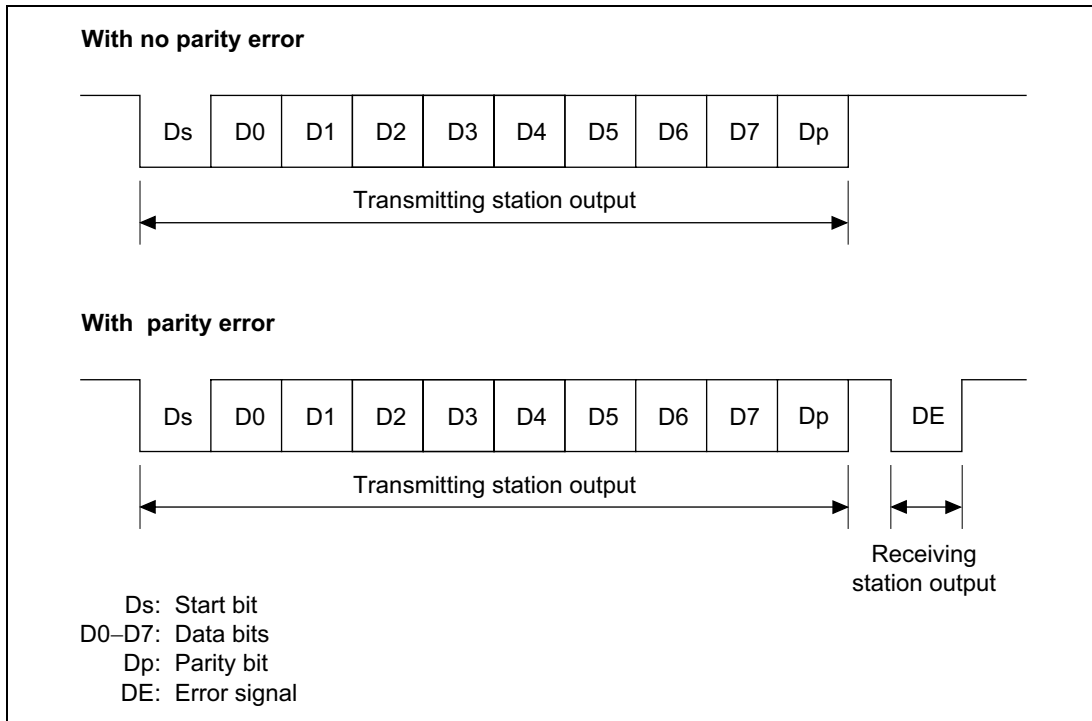

Figure 15.3 Data Format for Smart Card Interface

The operating sequence is:

1. The data line is high-impedance when not in use and is fixed high with a pull-up register.
2. The transmitting side starts one frame of data transmission. The data frame starts with a start bit (Ds, low level). The start bit is followed by eight data bits (D0–D7) and a parity bit (Dp).
3. On the smart card interface, the data line returns to high-impedance after this. The data line is pulled high with a pull-up register.
4. The receiving side checks parity. When the data is received normally with no parity errors, the receiving side then waits to receive the next data. When a parity error occurs, the receiving side outputs an error signal (DE, low level) and requests re-transfer of data. The receiving station returns the signal line to high-impedance after outputting the error signal for a specified period. The signal line is pulled high with a pull-up register.

- The transmitting side transmits the next frame of data unless it receives an error signal. If it does receive an error signal, it returns to step 2 to re-transmit the erroneous data.

15.3.4 Register Settings

Table 15.3 shows the bit map of the registers that the smart card interface uses. Bits shown as 1 or 0 must be set to the indicated value. The settings for the other bits are described below.

Table 15.3 Register Settings for Smart Card Interface

Register	Address	Bit 7	Bit 6	Bit 5	Bit 4	Bit 3	Bit 2	Bit 1	Bit 0
SCSMR	H'FFFFFFE80	C/\bar{A}	0	1	O/\bar{E}	1	0	CKS1	CKS0
SCBRR	H'FFFFFFE82	BRR7	BRR6	BRR5	BRR4	BRR3	BRR2	BRR1	BRR0
SCSCR	H'FFFFFFE84	TIE	RIE	TE	RE	0	0	CKE1	CKE0
SCTDR	H'FFFFFFE86	TDR7	TDR6	TDR5	TDR4	TDR3	TDR2	TDR1	TDR0
SCSSR	H'FFFFFFE88	TDRE	RDRF	ORER	FER/ ERS	PER	TEND	0	0
SCRDR	H'FFFFFFE8A	RDR7	RDR6	RDR5	RDR4	RDR3	RDR2	RDR1	RDR0
SCSCMR	H'FFFFFFE8C	—	—	—	—	SDIR	SINV	—	SMIF

Note: Dashes indicate unused bits.

- Setting the serial mode register (SCSMR): The C/\bar{A} bit selects the setting timing of the TEND flag, and selects the clock output state in combination with bits CKE1 and CKE0 in the serial control register (SCSCR). Clear the O/\bar{E} bit to 0 if the IC card uses the direct convention, and set it to 1 if the card uses the inverse convention. Select the on-chip baud rate generator clock source with the CKS1 and CKS0 bits (see section 15.3.5, Clock).
- Setting the bit rate register (SCBRR): Set the bit rate. See section 15.3.5, Clock, to see how to calculate the set value.
- Setting the serial control register (SCSCR): The TIE, RIE, TE and RE bits function as they do for the ordinary SCI. See section 14, Serial Communication Interface (SCI), for more information. The CKE0 bit specifies the clock output. When no clock is output, clear CKE0 to 0; when a clock is output, set CKE0 to 1.
- Setting the smart card mode register (SCSCMR): The SDIR and SINV bits are both cleared to 0 for IC cards that use the direct convention, and both set to 1 when the inverse convention is used. The SMIF bit is set to 1 for the smart card interface.

Figure 15.4 shows sample waveforms for register settings of the two types of IC cards (direct convention and inverse convention) and their start characters.

In the direct convention type, the logical 1 level is state Z, the logical 0 level is state A, and communication is LSB-first. The start character data is H'3B. Parity is even (from the smart card standard), and so the parity bit is 1.

In the inverse convention type, the logical 1 level is state A, the logical 0 level is state Z, and communication is MSB first. The start character data is H'3F. Parity is even (from the smart card standard), and so the parity bit is 0, which corresponds to state Z.

Only data bits D7–D0 are inverted by the SINV bit. To invert the parity bit, set the O/\bar{E} bit in SCSMR to odd parity mode. This applies to both transmission and reception.

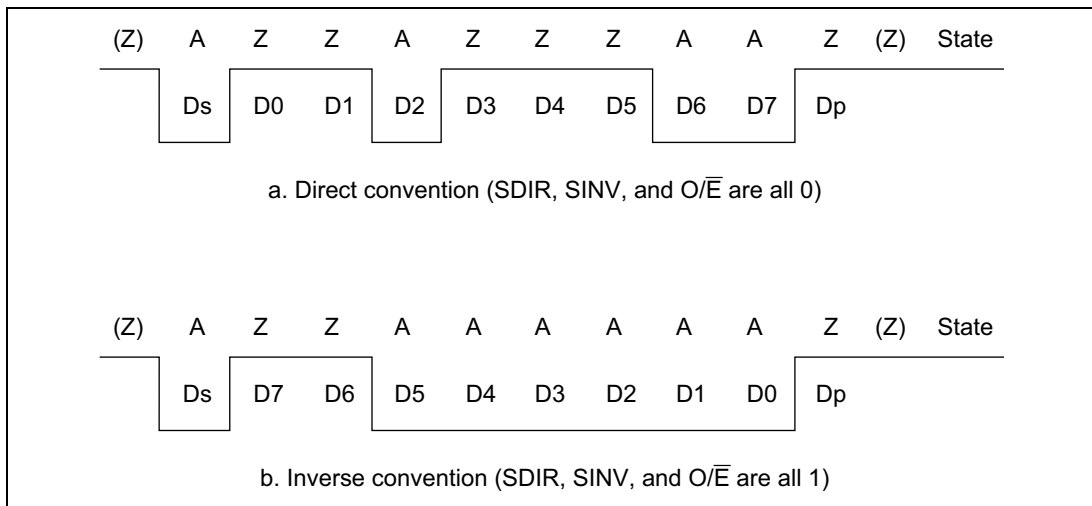

Figure 15.4 Waveform of Start Character

15.3.5 Clock

Only the internal clock generated by the on-chip baud rate generator can be used as the communication clock in the smart card interface. The bit rate for the clock is set by the bit rate register (SCBRR) and the CKS1 and CKS0 bits in the serial mode register (SCSMR), and is calculated using the equation below. Table 15.5 shows sample bit rates. If clock output is then selected by setting CKE0 to 1, a clock with a frequency 372 times the bit rate is output from the SCK0 pin.

$$B = \frac{P\phi}{1488 \times 2^{2n-1} \times (N + 1)} \times 10^6$$

Where: N = Value set in SCBRR ($0 \leq N \leq 255$)

B = Bit rate (bits/s)

$P\phi$ = Peripheral module operating frequency (MHz)

n = 0 to 3 (table 15.4)

Table 15.4 Relationship of n to CKS1 and CKS0

n	CKS1	CKS0
0	0	0
1	0	1
2	1	0
3	1	1

Table 15.5 Examples of Bit Rate B (Bits/s) for SCBRR Settings (n = 0)

N	P ϕ (MHz)						
	7.1424	10.00	10.7136	13.00	14.2848	16.00	18.00
0	9600.0	13440.9	14400.0	17473.1	19200.0	21505.4	24193.5
1	4800.0	6720.4	7200.0	8736.6	9600.0	10752.7	12096.8
2	3200.0	4480.3	4800.0	5824.4	6400.0	7168.5	8064.5

Note: The bit rate is rounded to one decimal place.

Calculate the value to be set in the bit rate register (SCBRR) from the operating frequency and the bit rate. N is an integer in the range $0 \leq N \leq 255$, specifying a smallish error.

$$N = \frac{P\phi}{1488 \times 2^{2n-1} \times B} \times 10^6 - 1$$

Table 15.6 Examples of SCBRR Settings for Bit Rate B (Bits/s) (n = 0)

ϕ (MHz) (9600 Bits/s)													
7.1424		10.00		10.7136		13.00		14.2848		16.00		18.00	
N	Error	N	Error	N	Error	N	Error	N	Error	N	Error	N	Error
0	0.00	1	30.00	1	25.00	1	8.99	1	0.00	1	12.01	2	15.99

Table 15.7 Maximum Bit Rates for Frequencies (Smart Card Interface Mode)

P ϕ (MHz)	Maximum Bit Rate (Bits/s)	N	n
7.1424	9600	0	0
10.00	13441	0	0
10.7136	14400	0	0
13.00	17473	0	0
14.2848	19200	0	0
16.00	21505	0	0
18.00	24194	0	0

The bit rate error is found as follows:

$$\text{Error (\%)} = \left(\frac{P\phi}{1488 \times 2^{2n-1} \times B \times (N + 1)} \times 10^6 - 1 \right) \times 100$$

Table 15.8 shows the relationship between transmit/receive clock register set values and output states on the smart card interface.

Table 15.8 Register Set Values and SCK Pin

Setting	Register Value				SCK Pin	
	SMIF	C \bar{A}	CKE1	CKE0	Output	State
1* ¹	1	0	0	0	Port	Determined by setting of port register SCP1MD1 and SCP1MD0 bits
	1	0	0	1	$\overline{\text{U}}\text{U}\text{U}$	SCK (serial clock) output state
2* ²	1	1	0	0	Low output	Low output state
	1	1	0	1	UUU	SCK (serial clock) output state
3* ²	1	1	1	0	High output	High output state
	1	1	1	1	$\overline{\text{U}}\text{U}\text{U}$	SCK (serial clock) output state

- Notes: 1. The SCK output state changes as soon as the CKE0 bit is modified. The CKE1 bit should be cleared to 0.
2. The clock duty remains constant despite stopping and starting of the clock by modification of the CKE0 bit.

15.3.6 Data Transmission and Reception

Initialization: Initialize the SCI using the following procedure before sending or receiving data. Initialization is also required for switching from transmit mode to receive mode or from receive mode to transmit mode. Figure 15.5 shows a flowchart of the initialization process.

1. Clear TE and RE in the serial control register (SCSCR) to 0.
2. Clear error flags FER/ERS, PER, and ORER to 0 in the serial status register (SCSSR).
3. Set the C/\bar{A} bit, parity bit (O/\bar{E} bit), and baud rate generator select bits (CKS1 and CKS0 bits) in the serial mode register (SCSMR). At this time also clear the CHR and MP bits to 0 and set the STOP and PE bits to 1.
4. Set the SMIF, SDIR, and SINV bits in the smart card mode register (SCSCMR). When the SMIF bit is set to 1, the TxD and RxD pins both switch from ports to SCI pins and become high-impedance.
5. Set the value corresponding to the bit rate in the bit rate register (SCBRR).
6. Set the clock source select bits (CKE1 and CKE0 bits) in the serial control register (SCSCR). Clear the TIE, RIE, TE, RE, MPIE, and TEIE bits to 0. When the CKE0 bit is set to 1, a clock is output from the SCK pin.
7. After waiting at least 1 bit, set the TIE, RIE, TE, and RE bits in SCSCR. Do not set the TE and RE bits simultaneously unless performing auto-diagnosis.

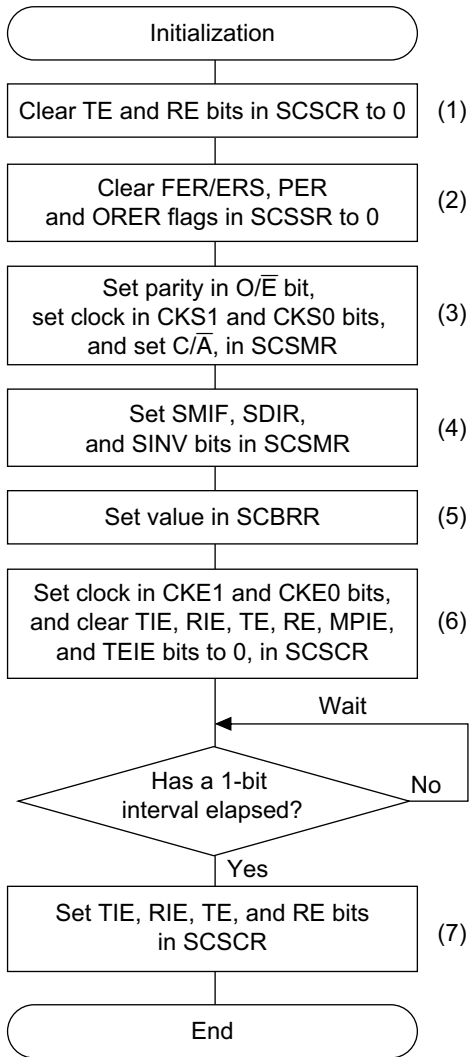

Note: Numbers in parentheses refer to steps in the preceding procedure description.

Figure 15.5 Initialization Flowchart (Example)

Serial Data Transmission: The processing procedures in the smart card mode differ from ordinary SCI processing because data is retransmitted when an error signal is sampled during a data transmission. This results in the transmission processing flowchart shown in figure 15.6.

1. Initialize the smart card interface mode as described in Initialization above.
2. Check that the FER/ERS bit in SCSSR is cleared to 0.
3. Repeat steps 2 and 3 until the TEND flag in SCSSR is set to 1.
4. Write the transmit data into SCTDR, clear the TDRE flag to 0 and start transmitting. The TEND flag will be cleared to 0.
5. To transmit more data, return to step 2.
6. To end transmission, clear the TE bit to 0.

This processing can be interrupted. When the TIE bit is set to 1 and interrupt requests are enabled, a transmit-data-empty interrupt (TXI) will be requested when the TEND flag is set to 1 at the end of transmission. When the RIE bit is set to 1 and interrupt requests are enabled, a communication error interrupt (ERI) will be requested when the ERS flag is set to 1 when an error occurs in transmission. See Interrupt Operation below for more information.

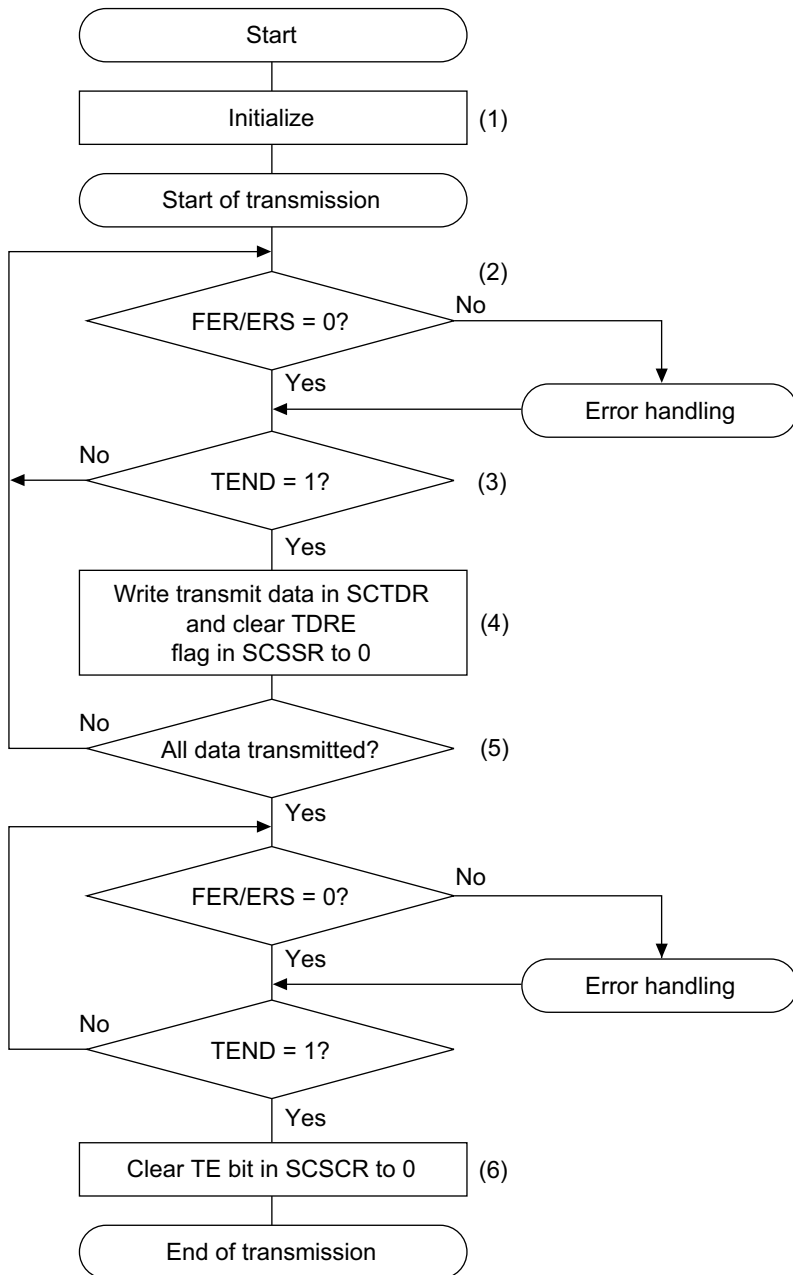

Note: Numbers in parentheses refer to steps in the preceding procedure description.

Figure 15.6 Transmission Flowchart

Serial Data Reception: The processing procedures in smart card mode are the same as in ordinary SCI processing. The reception processing flowchart is shown in figure 15.7.

1. Initialize the smart card interface mode as described above in Initialization and in figure 15.5.
2. Check that the ORER and PER flags in SCSSR are cleared to 0. If either flag is set, clear both to 0 after performing the appropriate error handling procedures.
3. Repeat steps 2 and 3 until the RDRF flag is set to 1.
4. Read the receive data from SCRDR.
5. To receive more data, clear the RDRF flag to 0 and return to step 2.
6. To end reception, clear the RE bit to 0.

This processing can be interrupted. When the RIE bit is set to 1 and interrupt requests are enabled, a receive-data-full interrupt (RXI) will be requested when the RDRF flag is set to 1 at the end of reception. When an error occurs during reception and either the ORER or PER flag is set to 1, a communication error interrupt (ERI) will be requested. See Interrupt Operation below for more information.

The received data will be transferred to SCRDR even when a parity error occurs during reception and PER is set to 1, so this data can still be read.

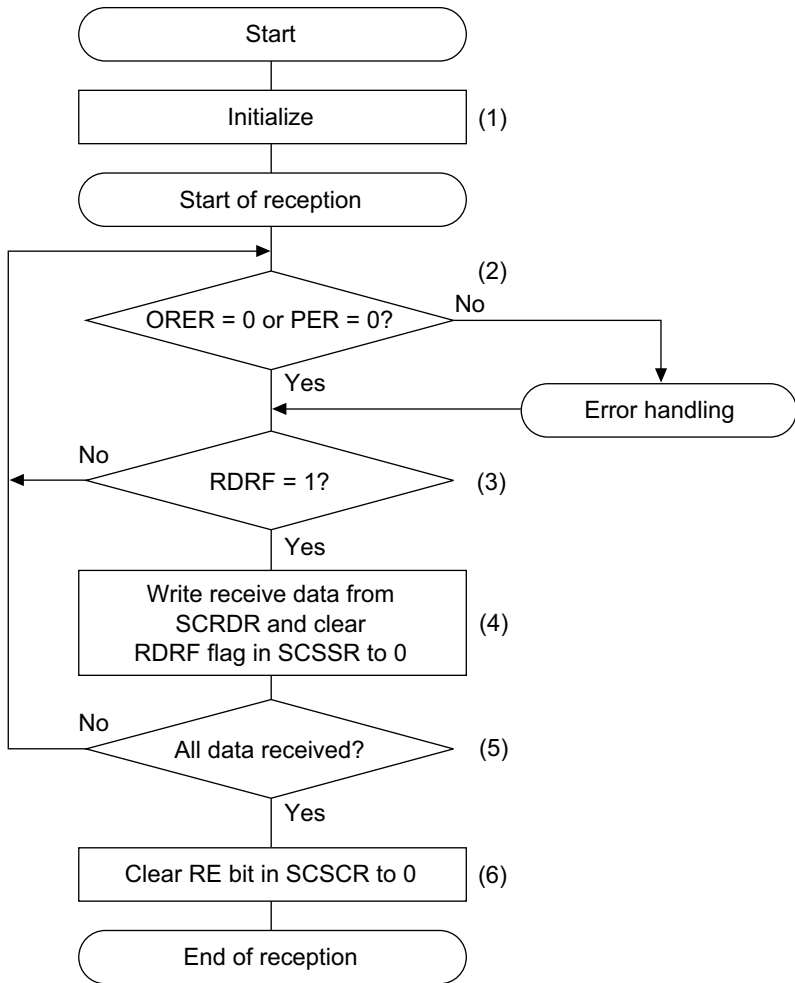

Note: Numbers in parentheses refer to steps in the preceding procedure description.

Figure 15.7 Reception Flowchart (Example)

Switching Modes: When switching from receive mode to transmit mode, check that the receive operation is completed before starting initialization, clearing RE to 0, and setting TE to 1. The RDRF, PER, and ORER flags can be used to check if reception is completed. When switching from transmit mode to receive mode, check that the transmit operation is completed before starting initialization, clearing TE to 0, and setting RE to 1. The TEND flag can be used to check if transmission is completed.

Interrupt Operation: In the smart card interface mode, there are three types of interrupts: transmit-data-empty (TXI), communication error (ERI) and receive-data-full (RXI). In this mode, the transmit-end interrupt (TEI) cannot be requested.

Set the TEND flag in SCSSR to 1 to request a TXI interrupt. Set the RDRF flag in SCSSR to 1 to request an RXI interrupt. Set the ORER, PER, or FER/ERS flag in SCSSR to 1 to request an ERI interrupt (table 15.9).

Table 15.9 Smart Card Mode Operating State and Interrupt Sources

Mode	State	Flag	Mask Bit	Interrupt Source
Transmit mode	Normal	TEND	TIE	TXI
	Error	FER/ERS	RIE	ERI
Receive mode	Normal	RDRF	RIE	RXI
	Error	PER, ORER	RIE	ERI

15.4 Usage Notes

When the SCI is used as a smart card interface, be sure that all criteria in sections 15.4.1, Receive Data Timing and Receive Margin in Asynchronous Mode and 15.4.2, Retransmission are applied.

15.4.1 Receive Data Timing and Receive Margin in Asynchronous Mode

In asynchronous mode, the SCI runs on a base clock with a frequency of 372 times the transfer rate. During reception, the SCI samples the falling of the start bit using the base clock to achieve internal synchronization. Receive data is latched internally at the rising edge of the 186th base clock cycle (figure 15.8).

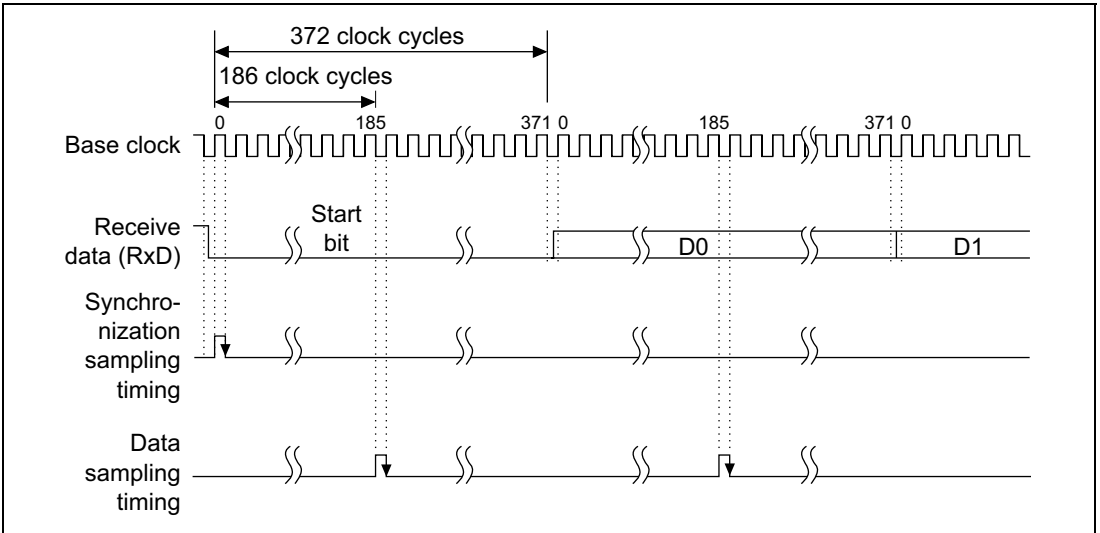

Figure 15.8 Receive Data Sampling Timing in Smart Card Mode

The receive margin is found from the following equation:

For smart card mode:

$$M = \left| \left(0.5 - \frac{1}{2N} \right) - (L - 0.5)F - \frac{|D - 0.5|}{N} (1 + F) \right| \times 100\%$$

Where: M = Receive margin (%)

N = Ratio of bit rate to clock (N = 372)

D = Clock duty (D = 0 to 1.0)

L = Frame length (L = 10)

F = Absolute value of clock frequency deviation

Using this equation, the receive margin when F = 0 and D = 0.5 is as follows:

$$M = \left(0.5 - \frac{1}{2 \times 372} \right) \times 100\% = 49.866\%$$

15.4.2 Retransmission (Receive and Transmit Modes)

Retransmission when SCI is in Receive Mode: Figure 15.9 shows the retransmission operation in the SCI receive mode.

1. When the received parity bit is checked and an error is found, the PER bit in SCSSR is automatically set to 1. If the RIE bit in SCSCR is enabled at this time, an ERI interrupt is requested. Be sure to clear the PER bit before the next parity bit is sampled.
2. The RDRF bit in SCSSR is not set in the frame that caused the error.
3. When the received parity bit is checked and no error is found, the PER bit in SCSSR is not set.
4. When the received parity bit is checked and no error is found, reception is considered to have been completed normally and the RDRF bit in SCSSR is automatically set to 1. If the RIE bit in SCSCR is enabled at this time, an RXI interrupt is requested.
5. When a normal frame is received, the pin maintains a three-state state when it transmits the error signal.

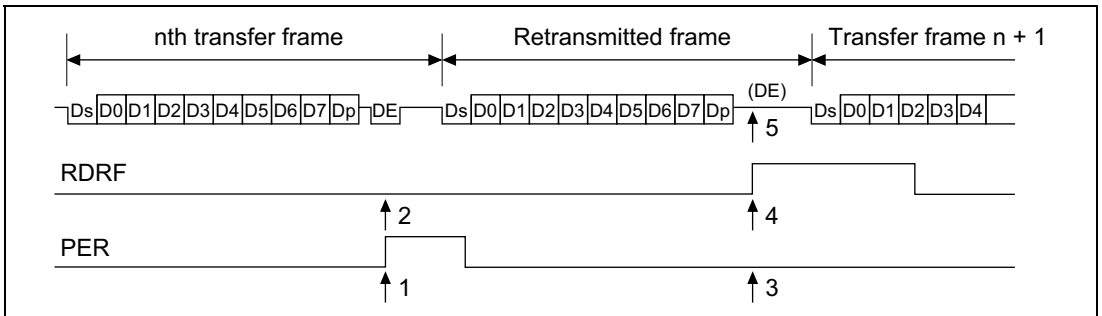

Figure 15.9 Retransmission in SCI Receive Mode

Retransmission when SCI is in Transmit Mode: Figure 15.10 shows the retransmission operation in the SCI transmit mode.

1. After transmission of one frame is completed, the FER/ERS bit in SCSSR is set to 1 when an error signal is returned from the receiving side. If the RIE bit in SCSCR is enabled at this time, an ERI interrupt is requested. Be sure to clear the FER/ERS bit before the next parity bit is sampled.
2. The TEND bit in SCSSR is not set in the frame that received the error signal indicating the error.
3. The FER/ERS bit in SCSSR is not set when no error signal is returned from the receiving side.
4. When no error signal is returned from the receiving side, the TEND bit in SCSSR is set to 1 when the transmission of the frame that includes the retransmission is considered completed. If the TIE bit in SCSCR is enabled at this time, a TXI interrupt will be requested.

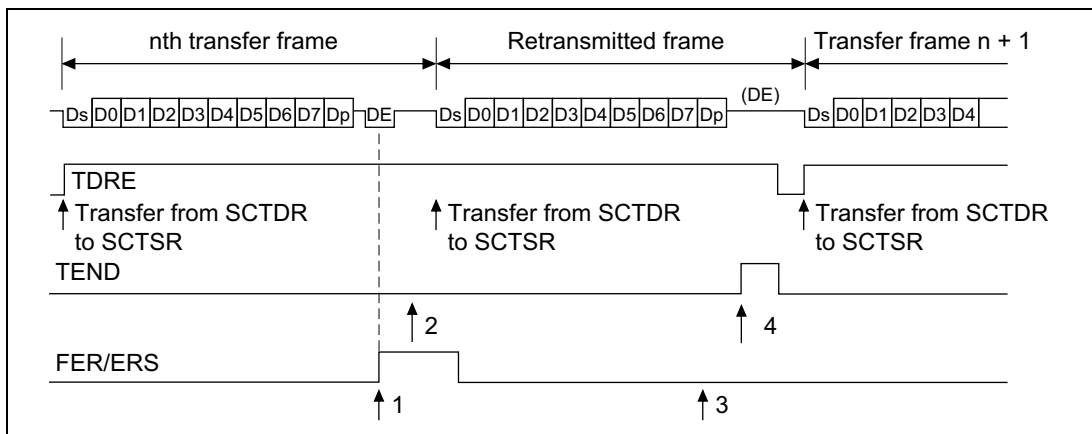

Figure 15.10 Retransmission in SCI Transmit Mode

Section 16 Serial Communication Interface with FIFO (SCIF)

16.1 Overview

The SH7709S has a two-channel serial communication interface with FIFO (SCIF) that supports asynchronous serial communication. It also has 16-stage FIFO registers for both transmission and reception that enable the SH7709S to perform efficient high-speed continuous communication.

16.1.1 Features

- Asynchronous serial communication:
 - Serial data communication is performed by start-stop in character units. The SCI can communicate with a universal asynchronous receiver/transmitter (UART), an asynchronous communication interface adapter (ACIA), or any other communications chip that employs a standard asynchronous serial system. There are eight selectable serial data communication formats.
 - Data length: 7 or 8 bits
 - Stop bit length: 1 or 2 bits
 - Parity: Even, odd, or none
 - Receive error detection: Parity and framing errors
 - Break detection: Break is detected when a framing error is followed by at least one frame at the space 0 level (low level). It is also detected by reading the RxD level directly from the port SC data register (SCPDR) when a framing error occurs.
- Full duplex communication: The transmitting and receiving sections are independent, so the SCI can transmit and receive simultaneously. Both sections use 16-stage FIFO buffering, so high-speed continuous data transfer is possible in both the transmit and receive directions.
- On-chip baud rate generator with selectable bit rates
- Internal or external transmit/receive clock source: From either baud rate generator (internal) or SCK pin (external)
- Four types of interrupts: Transmit-FIFO-data-empty, break, receive-FIFO-data-full, and receive-error interrupts are requested independently. The direct memory access controller (DMAC) can be activated to execute a data transfer by a transmit-FIFO-data-empty or receive-FIFO-data-full interrupt.
- When the SCIF is not in use, it can be stopped by halting the clock supplied to it, saving power.
- On-chip modem control functions (RTS and CTS)
- The quantity of data in the transmit and receive FIFO registers and the number of receive errors of the receive data in the receive FIFO register can be ascertained.
- A time-out error (DR) can be detected when receiving.

16.1.2 Block Diagram

Figure 16.1 shows a block diagram of the SCIF.

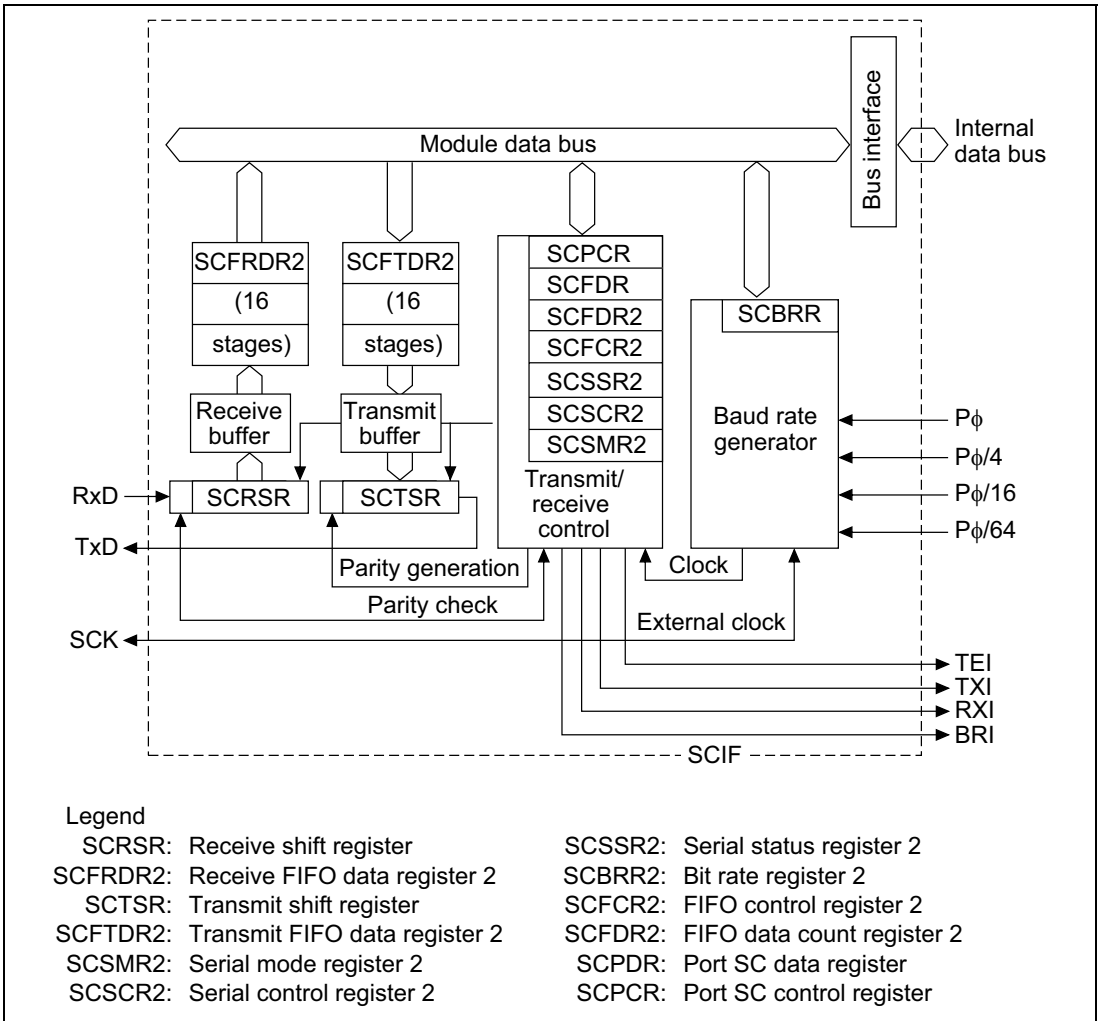

Figure 16.1 Block Diagram of SCIF

Figures 16.2 to 16.4 show the SCIF I/O port pins.

SCIF pin I/O and data control is performed by bits 11 to 8 of SCPCR and bits 5 and 4 of SCPDR. For details, see section 14.2.8, SC Port Control Register (SCPCR)/SC Port Data Register (SCPDR).

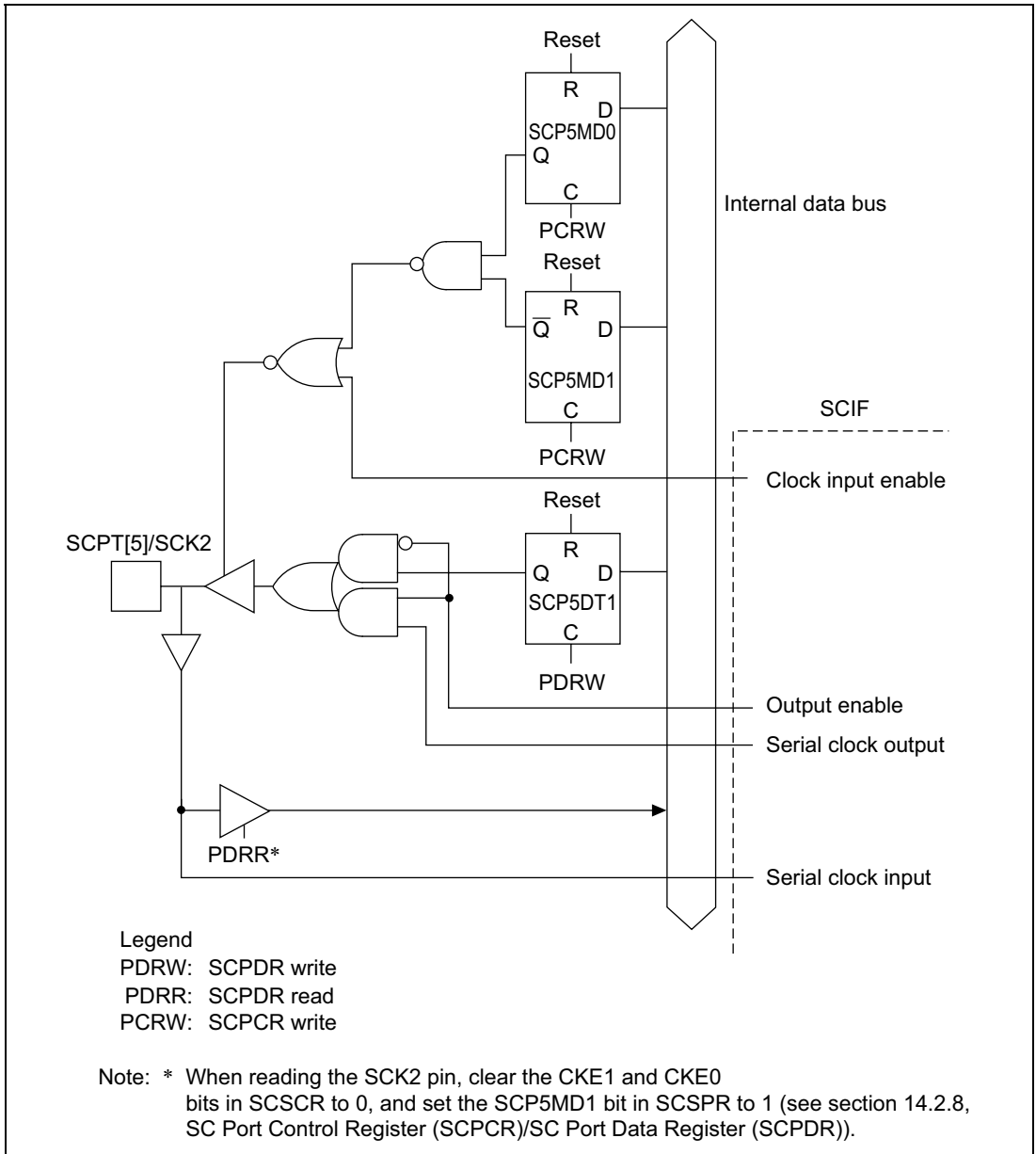

Figure 16.2 SCPT[5]/SCK2 Pin

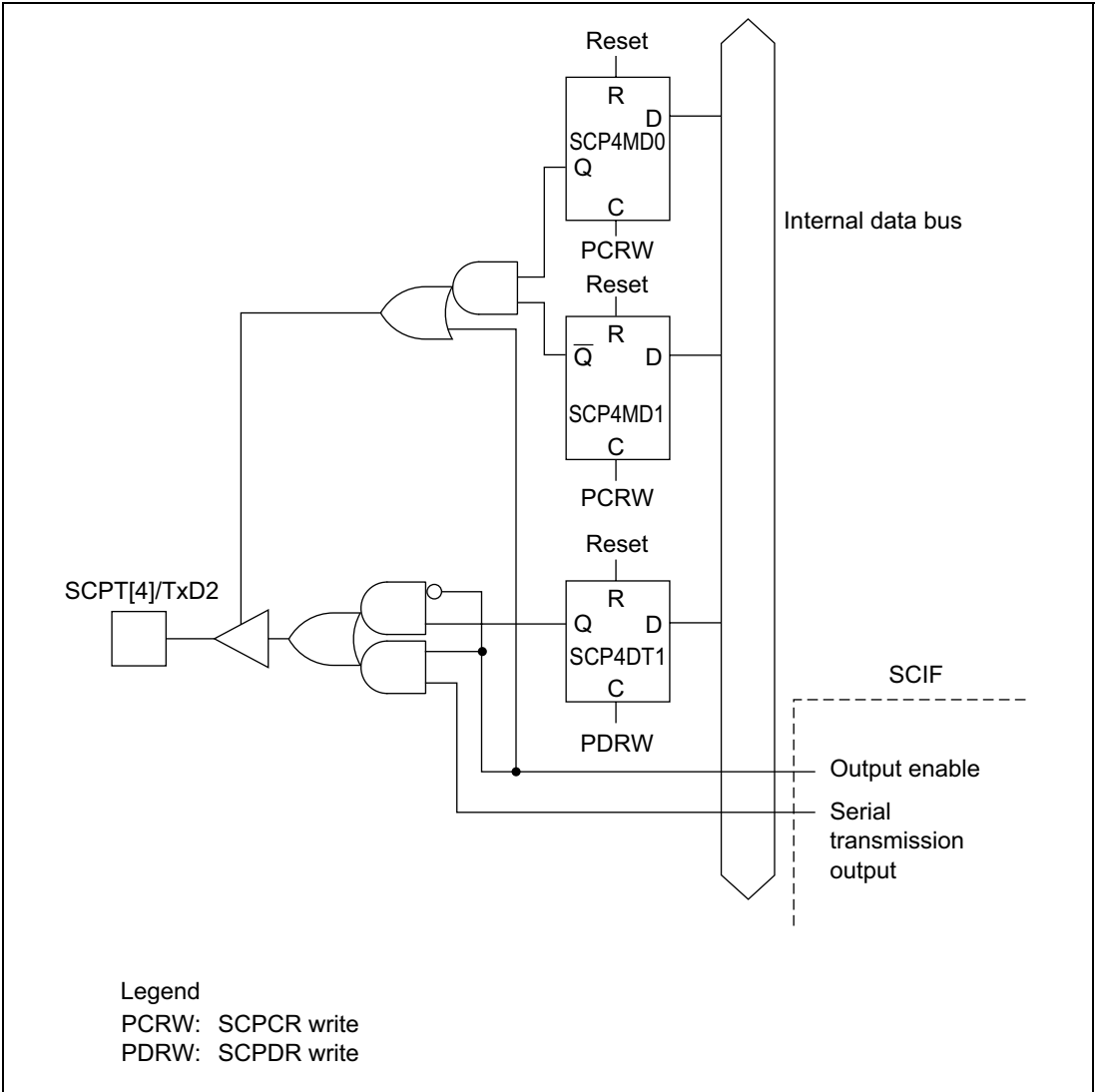

Figure 16.3 SCPT[4]/TxD2 Pin

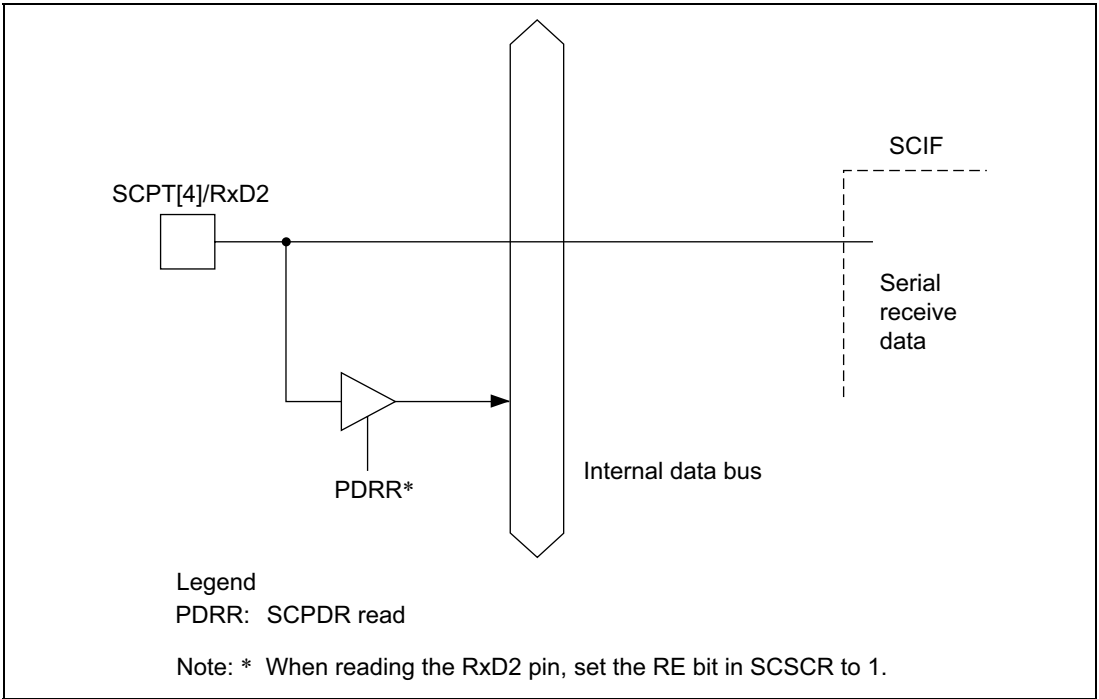

Figure 16.4 SCPT[4]/RxD2 Pin

16.1.3 Pin Configuration

The SCIF has the serial pins summarized in table 16.1.

Table 16.1 SCIF Pins

Pin Name	Abbreviation	I/O	Function
Serial clock pin	SCK2	I/O	Clock I/O
Receive data pin	RxD2	Input	Receive data input
Transmit data pin	TxD2	Output	Transmit data output
Request to send pin	$\overline{\text{RTS2}}$	Output	Request to send
Clear to send pin	$\overline{\text{CTS2}}$	Input	Clear to send

16.1.4 Register Configuration

Table 16.2 summarizes the SCIF internal registers. These registers specify the data format and bit rate, and control the transmitter and receiver sections.

Table 16.2 SCIF Registers

Register Name	Abbreviation	R/W	Initial Value	Address	Access size
Serial mode register 2	SCSMR2	R/W	H'00	H'04000150 (H'A4000150)* ²	8 bits
Bit rate register 2	SCBRR2	R/W	H'FF	H'04000152 (H'A4000152)* ²	8 bits
Serial control register 2	SCSCR2	R/W	H'00	H'04000154 (H'A4000154)* ²	8 bits
Transmit FIFO data register 2	SCFTDR2	W	—	H'04000156 (H'A4000156)* ²	8 bits
Serial status register 2	SCSSR2	R/(W)* ¹	H'0060	H'04000158 (H'A4000158)* ²	16 bits
Receive FIFO data register 2	SCFRDR2	R	Undefined	H'0400015A (H'A400015A)* ²	8 bits
FIFO control register 2	SCFCR2	R/W	H'00	H'0400015C (H'A400015C)* ²	8 bits
FIFO data count register 2	SCFDR2	R	H'0000	H'0400015E (H'A400015E)* ²	16 bits

Notes: These registers are located in area 1 of physical space. Therefore, when the cache is on, either access these registers from the P2 area of logical space or else make an appropriate setting using the MMU so that these registers are not cached.

1. Only 0 can be written to clear the flag.
2. When address translation by the MMU does not apply, the address in parentheses should be used.

16.2 Register Descriptions

16.2.1 Receive Shift Register (SCRSR)

The receive shift register (SCRSR) receives serial data. Data input at the RxD pin is loaded into SCRSR in the order received, LSB (bit 0) first, converting the data to parallel form. When one byte has been received, it is automatically transferred to SCFRDR, the receive FIFO data register. The CPU cannot read or write to SCRSR directly.

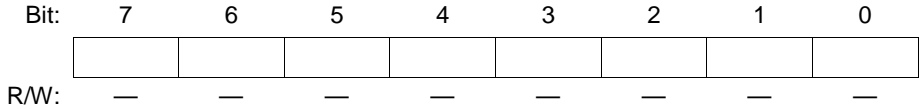

16.2.2 Receive FIFO Data Register (SCFRDR)

The 16-byte receive FIFO data register (SCFRDR) stores serial receive data. The SCIF completes the reception of one byte of serial data by moving the received data from the receive shift register (SCRSR) into SCFRDR for storage. Continuous reception is possible until 16 bytes are stored.

The CPU can read but not write to SCFRDR. If data is read when there is no receive data in the SCFRDR, the value is undefined. When this register is full of receive data, subsequent serial data is lost.

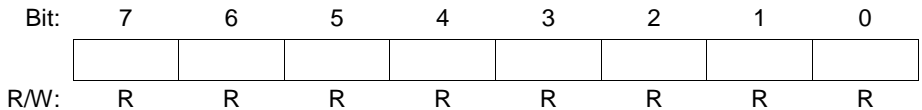

16.2.3 Transmit Shift Register (SCTSR)

The transmit shift register (SCTSR) transmits serial data. The SCI loads transmit data from the transmit FIFO data register (SCFTDR) into SCTSR, then transmits the data serially from the TxD pin, LSB (bit 0) first. After transmitting one data byte, the SCI automatically loads the next transmit data from SCFTDR into SCTSR and starts transmitting again. The CPU cannot read or write to SCTSR directly.

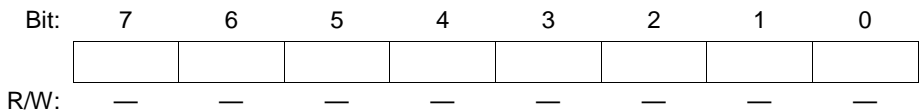

16.2.4 Transmit FIFO Data Register (SCFTDR)

The transmit FIFO data register (SCFTDR) is a FIFO register comprising sixteen 8-bit stages that stores data for serial transmission. When the SCIF detects that the transmit shift register (SCTSR) is empty, it moves transmit data written in the SCFTDR into SCTSR and starts serial transmission. Continuous serial transmission is performed until there is no transmit data left in SCFTDR. The CPU can always write to SCFTDR.

When SCFTDR is full of transmit data (16 stages), no more data can be written. If writing of new data is attempted, the data is ignored.

Bit:	7	6	5	4	3	2	1	0
R/W:	W	W	W	W	W	W	W	W

16.2.5 Serial Mode Register (SCSMR)

The serial mode register (SCSMR) is an 8-bit register that specifies the SCIF serial communication format and selects the clock source for the baud rate generator.

The CPU can always read and write to SCSMR. SCSMR is initialized to H'00 by a reset and in standby or module standby mode.

Bit:	7	6	5	4	3	2	1	0
	—	CHR	PE	O \bar{E}	STOP	—	CKS1	CKS0
Initial value:	0	0	0	0	0	0	0	0
R/W:	R	R/W	R/W	R/W	R/W	R	R/W	R/W

Bit 7—Reserved: This bit is always read as 0. The write value should always be 0.

Bit 6—Character Length (CHR): Selects 7-bit or 8-bit data in asynchronous mode.

Bit 6: CHR	Description
0	8-bit data (Initial value)
1	7-bit data*

Note: * When 7-bit data is selected, the MSB (bit 7) of the transmit FIFO data register is not transmitted.

Bit 5—Parity Enable (PE): Selects whether to add a parity bit to transmit data and to check the parity of receive data.

Bit 5: PE	Description
0	Parity bit not added or checked (Initial value)
1	Parity bit added and checked*

Note: * When PE is set to 1, an even or odd parity bit is added to transmit data, depending on the parity mode (O/ \bar{E}) setting. Receive data parity is checked according to the even/odd (O/ \bar{E}) mode setting.

Bit 4—Parity Mode (O/ \bar{E}): Selects even or odd parity when parity bits are added and checked. The O/ \bar{E} setting is used only when the parity enable bit (PE) is set to 1 to enable parity addition and checking. The O/ \bar{E} setting is ignored when parity addition and checking is disabled.

Bit 4: O/ \bar{E}	Description
0	Even parity* ¹ (Initial value)
1	Odd parity* ²

Notes: 1. If even parity is selected, the parity bit is added to transmit data to make an even number of 1s in the transmitted character and parity bit combined. Receive data is checked to see if it has an even number of 1s in the received character and parity bit combined.
2. If odd parity is selected, the parity bit is added to transmit data to make an odd number of 1s in the transmitted character and parity bit combined. Receive data is checked to see if it has an odd number of 1s in the received character and parity bit combined.

Bit 3—Stop Bit Length (STOP): Selects one or two bits as the stop bit length.

When receiving, only the first stop bit is checked, regardless of the STOP bit setting. If the second stop bit is 1, it is treated as a stop bit, but if the second stop bit is 0, it is treated as the start bit of the next incoming character.

Bit 3: STOP	Description
0	One stop bit* ¹ (Initial value)
1	Two stop bits* ²

Notes: 1. When transmitting, a single 1-bit is added at the end of each transmitted character.
2. When transmitting, two 1-bits are added at the end of each transmitted character.

Bit 2—Reserved: This bit is always read as 0. The write value should always be 0.

Bits 1 and 0—Clock Select 1 and 0 (CKS1, CKS0): Select the internal clock source of the on-chip baud rate generator. According to the setting of the CKS1 and CKS0 bits four clock sources are available. P ϕ , P ϕ /4, P ϕ /16 and P ϕ /64. For further information on the clock source, bit rate register settings, and baud rate, see section 16.2.8, Bit Rate Register (SCBRR).

Bit 1: CKS1	Bit 0: CKS0	Description
0	0	P ϕ (Initial value)
	1	P ϕ /4
1	0	P ϕ /16
	1	P ϕ /64

Note: P ϕ : Peripheral clock

16.2.6 Serial Control Register (SCSCR)

The serial control register (SCSCR) operates the SCIF transmitter/receiver, selects the serial clock output in asynchronous mode, enables/disables interrupt requests, and selects the transmit/receive clock source. The CPU can always read and write to SCSCR. SCSCR is initialized to H'00 by a reset and in standby or module standby mode.

Bit:	7	6	5	4	3	2	1	0
	TIE	RIE	TE	RE	—	—	CKE1	CKE0
Initial value:	0	0	0	0	0	0	0	0
R/W:	R/W	R/W	R/W	R/W	R	R	R/W	R/W

Bit 7—Transmit Interrupt Enable (TIE): Enables or disables the transmit-FIFO-data-empty interrupt (TXI) requested when the serial transmit data is transferred from the transmit FIFO data register (SCFTDR) to the transmit shift register (SCTSR), when the quantity of data in the transmit FIFO register becomes less than the specified number of transmission triggers, and when the TDFE flag in the serial FIFO status register (SCFSR) is set to 1.

Bit 7: TIE	Description
0	Transmit-FIFO-data-empty interrupt request (TXI) is disabled* (Initial value)
1	Transmit-FIFO-data-empty interrupt request (TXI) is enabled

Note: * The TXI interrupt request can be cleared by writing a greater quantity of transmit data than the specified transmission trigger number to SCFTDR and by clearing TDFE to 0 after reading 1 from TDFE, or can be cleared by clearing TIE to 0.

Bit 6—Receive Interrupt Enable (RIE): Enables or disables the receive-data-full (RXI) and receive-error (ERI) interrupts requested when serial receive data is transferred from the receive shift register (SCRSR) to the receive FIFO data register (SCFRDR), when the quantity of data in the receive FIFO register becomes more than the specified receive trigger number, and when the RDRF flag in SCSSR is set to 1.

Bit 6: RIE	Description
0	Receive-data-full interrupt (RXI), receive-error interrupt (ERI), and receive break interrupt (BRI) requests are disabled* (Initial value)
1	Receive-data-full interrupt (RXI) and receive-error interrupt (ERI) requests are enabled

Note: * RXI and ERI interrupt requests can be cleared by reading the DR, ER, or RDF flag after it has been set to 1, then clearing the flag to 0, or by clearing RIE to 0. With the RDF flag, read 1 from the RDF flag and clear it to 0, after reading receive data from SCRDR until the quantity of receive data becomes less than the specified receive trigger number.

Bit 5—Transmit Enable (TE): Enables or disables the SCIF serial transmitter.

Bit 5: TE	Description
0	Transmitter disabled (Initial value)
1	Transmitter enabled*

Note: * Serial transmission starts after writing of transmit data into SCFTDR2. Select the transmit format in SCSMR2 and SCFCR2 and reset the TFIFO before setting TE to 1.

Bit 4—Receive Enable (RE): Enables or disables the SCIF serial receiver.

Bit 4: RE	Description
0	Receiver disabled* ¹ (Initial value)
1	Receiver enabled* ²

Notes: 1. Clearing RE to 0 does not affect the receive flags (DR, ER, BRK, FER, PER, and ORER). These flags retain their previous values.
 2. Serial reception starts when a start bit is detected. Select the receive format in SCSMR2 before setting RE to 1.

Bits 3 and 2—Reserved: These bits are always read as 0. The write value should always be 0.

Bits 1 and 0—Clock Enable 1 and 0 (CKE1, CKE0): Select the SCIF clock source and enable or disable clock output from the SCK pin. Depending on the combination of CKE1 and CKE0, the SCK pin can be used for serial clock output or serial clock input.

The CKE0 setting is valid only when the SCIF is operating on the internal clock (CKE1 = 0). The CKE0 setting is ignored when an external clock source is selected (CKE1 = 1). Before selecting the SCIF operating mode in the serial mode register (SCSMR), set CKE1 and CKE0. For further details on selection of the SCIF clock source, see table 16.7 in section 16.3, Operation.

Bit 1: CKE1	Bit 0: CKE0	Description
0	0	Internal clock, SCK pin used for input pin (input signal is ignored) (Initial value)
	1	Internal clock, SCK pin used for clock output* ¹
1	0	External clock, SCK pin used for clock input* ²
	1	External clock, SCK pin used for clock input* ²

Notes: 1. The output clock frequency is 16 times the bit rate.
2. The input clock frequency is 16 times the bit rate.

16.2.7 Serial Status Register (SCSSR)

The serial status register (SCSSR) is a 16-bit register. The upper 8 bits indicate the number of receive errors in the SCFRDR data, and the lower 8 bits indicate the SCIF operating state.

The CPU can always read and write to SCSSR, but cannot write 1 to the status flags (ER, TEND, TDFE, BRK, OPER, and DR). These flags can be cleared to 0 only if they have first been read (after being set to 1). Bits 3 (FER) and 2 (PER) are read-only bits that cannot be written. SCSSR is initialized to H'0060 by a reset and in standby or module standby mode.

Lower 8 bits:	7	6	5	4	3	2	1	0
	ER	TEND	TDFE	BRK	FER	PER	RDF	DR
Initial value:	0	1	1	0	0	0	0	0
R/W:	R/(W)*	R/(W)*	R/(W)*	R/(W)*	R	R	R/(W)*	R/(W)*

Note: * The only value that can be written is 0 to clear the flag.

Bit 7—Receive Error (ER): Indicates the occurrence of a framing error, or of a parity error when receiving data that includes parity.

Bit 7: ER	Description
0	Receiving is in progress or has ended normally* ¹ (Initial value) [Clearing conditions] (1) By a power-on reset or in standby mode ER is cleared to 0 when the chip is reset or enters standby mode (2) When 0 is written after 1 is read from ER
1	A framing error or parity error has occurred* ² [Setting conditions] (1) ER is set to 1 when the stop bit is 0 after checking whether or not the last stop bit of the received data is 1 at the end of one data receive operation* ² (2) When the total number of 1s in the receive data plus parity bit does not match the even/odd parity specified by the O/ \bar{E} bit in SCSSMR

Notes: 1. Clearing the RE bit to 0 in SCSCR does not affect the ER bit, which retains its previous value. Even if a receive error occurs, the receive data is transferred to SCFRDR and the receive operation is continued. Whether or not the data read from SCRDR includes a receive error can be detected by the FER and PER bits in SCSSR.

2. In stop mode, only the first stop bit is checked; the second stop bit is not checked.

Bit 6—Transmit End (TEND): Indicates that when the last bit of a serial character was transmitted, SCFTDR did not contain valid data, so transmission has ended.

Bit 6: TEND	Description
0	Transmission is in progress [Clearing condition] When data is written in SCFTDR
1	End of transmission (Initial value) [Setting conditions] (1) When the chip is reset or enters standby mode, when TE is cleared to 0 in the serial control register (SCSCR) (2) When SCFTDR does not contain receive data when the last bit of a one-byte serial character is transmitted

Bit 5—Transmit FIFO Data Empty (TDFE): Indicates that data has been transferred from the transmit FIFO data register (SCFTDR) to the transmit shift register (SCTSR), the quantity of data in SCFTDR has become less than the transmission trigger number specified by the TTRG1 and TTRG0 bits in the FIFO control register (SCFCR), and writing of transmit data to SCFTDR is enabled.

Bit 5: TDFE	Description
0	The quantity of transmit data written to SCFTDR is greater than the specified transmission trigger number (Initial value) [Clearing condition] TDFE is cleared to 0 when data exceeding the specified transmission trigger number is written to SCFTDR, or when software reads TDFE after it has been set to 1, then writes 0 to TDFE
1	The quantity of transmit data in SCFTDR is less than the specified transmission trigger number* [Setting conditions] (1) TDFE is set to 1 by a reset or in standby mode (2) When the quantity of transmit data in SCFTDR becomes less than the specified transmission trigger number as a result of transmission

Note: * Since SCFTDR is a 16-byte FIFO register, the maximum quantity of data that can be written when TDFE is 1 is “16 minus the specified transmission trigger number”. If an attempt is made to write additional data, the data is ignored. The quantity of data in SCFTDR is indicated by the upper 8 bits of SCFTDR.

Bit 4—Break Detection (BRK): Indicates that a break signal has been detected in receive data.

Bit 4: BRK	Description
0	No break signal received (Initial value) [Clearing conditions] (1) BRK is cleared to 0 when the chip is reset or enters standby mode (2) When software reads BRK after it has been set to 1, then writes 0 to BRK
1	Break signal received* [Setting conditions] (1) BRK is set to 1 when data including a framing error is received (2) A framing error occurs with space 0 in the subsequent receive data

Note: * When a break is detected, transfer of the receive data (H'00) to SCFRDR stops after detection. When the break ends and the receive signal becomes mark 1, the transfer of receive data resumes. The receive data of a frame in which a break signal is detected is transferred to SCFRDR. After this, however, no receive data is transferred until a break ends with the received signal being mark 1, and the next data is received.

Bit 3—Framing Error (FER): Indicates a framing error in the data read from the receive FIFO data register (SCFRDR).

Bit 3: FER	Description
0	No receive framing error occurred in the data read from SCFRDR (Initial value) [Clearing conditions] (1) When the chip undergoes a power-on reset or enters standby mode (2) When no framing error is present in the data read from SCFRDR
1	A receive framing error occurred in the data read from SCFRDR [Setting condition] When a framing error is present in the data read from SCFRDR

Bit 2—Parity Error (PER): Indicates a parity error in the data read from the receive FIFO data register (SCFRDR).

Bit 2: PER	Description
0	No receive parity error occurred in the data read from SCFRDR (Initial value) [Clearing conditions] (1) When the chip undergoes a power-on reset or enters standby mode (2) When no parity error is present in the data read from SCFRDR
1	A receive framing error occurred in the data read from SCFRDR [Setting condition] When a parity error is present in the data read from SCFRDR

Bit 1—Receive FIFO Data Full (RDF): Indicates that receive data has been transferred to the receive FIFO data register (SCFRDR), and the quantity of data in SCFRDR has become greater than the receive trigger number specified by the RTRG1 and RTRG0 bits in the FIFO control register (SCFCR).

Bit 1: RDF	Description
0	The quantity of transmit data written to SCFRDR is less than the specified receive trigger number (Initial value) [Clearing conditions] (1) By a power-on reset or in standby mode (2) When the quantity of receive data in SCFRDR is less than the specified receive trigger value and 1 is read from RDF, which is then cleared to 0
1	The quantity of receive data in SCFRDR is greater than the specified receive trigger number [Setting condition] When a quantity of receive data greater than the specified receive trigger number is stored in SCFRDR*

Note: * Since SCFTDR is a 16-byte FIFO register, the maximum quantity of data that can be read when RDF is 1 is the specified receive trigger number. If an attempt is made to read after all the data in SCFRDR has been read, the data is undefined. The quantity of receive data in SCFRDR is indicated by the lower 8 bits of SCFTDR.

Bit 0—Receive Data Ready (DR): Indicates that the quantity of data in the receive FIFO data register (SCFRDR) is less than the specified receive trigger number, and that the next data has not yet been received after the elapse of 15 etu from the last stop bit.

Bit 0: DR	Description
0	Receiving is in progress, or no receive data remains in SCFRDR after receiving ended normally (Initial value) [Clearing conditions] (1) When the chip undergoes a power-on reset or enters standby mode (2) When software reads DR after it has been set to 1, then writes 0 to DR
1	Next receive data has not been received [Setting condition] When SCFRDR contains less data than the specified receive trigger number, and the next data has not yet been received after the elapse of 15 etu from the last stop bit*

Note: * This is equivalent to 1.5 frames with the 8-bit, 1-stop-bit format. (etu: elementary time unit)

Upper 8 bits:	15	14	13	12	11	10	9	8
	PER3	PER2	PER1	PER0	FER3	FER2	FER1	FER0
Initial value:	0	0	0	0	0	0	0	0
R/W:	R	R	R	R	R	R	R	R

Bits 15 to 12—Number of Parity Errors 3 to 0 (PER3 to PER0): Indicate the quantity of data including a parity error in the receive data stored in the receive FIFO data register (SCFRDR). The value indicated by bits 15 to 12 represents the number of parity errors in SCFRDR.

Bits 11 to 8—Number of Framing Errors 3 to 0 (FER3 to FER0): Indicate the quantity of data including a framing error in the receive data stored in SCFRDR. The value indicated by bits 11 to 8 represents the number of framing errors in SCFRDR.

16.2.8 Bit Rate Register (SCBRR)

The bit rate register (SCBRR) is an 8-bit register that, together with the baud rate generator clock source selected by the CKS1 and CKS0 bits in the serial mode register (SCSMR), determines the serial transmit/receive bit rate.

The CPU can always read and write to SCBRR. SCBRR is initialized to H'FF by a reset and in module standby or standby mode. Each channel has independent baud rate generator control, so different values can be set in two channels.

Bit:	7	6	5	4	3	2	1	0
Initial value:	1	1	1	1	1	1	1	1
R/W:	R/W	R/W	R/W	R/W	R/W	R/W	R/W	R/W

The SCBRR setting is calculated as follows:

Asynchronous mode:

$$N = \frac{P\phi}{64 \times 2^{2n-1} \times B} \times 10^6 - 1$$

B: Bit rate (bits/s)

N: SCBRR setting for baud rate generator ($0 \leq N \leq 255$)

P ϕ : Operating frequency for peripheral modules (MHz)

n: Baud rate generator clock source ($n = 0, 1, 2, 3$) (for the clock sources and values of n, see table 16.3.)

Table 16.3 SCSMR Settings

n	Clock Source	SCSMR Settings	
		CKS1	CKS0
0	P ϕ	0	0
1	P ϕ /4	0	1
2	P ϕ /16	1	0
3	P ϕ /64	1	1

Note: The bit rate error is given by the following formula:

$$\text{Error (\%)} = \left\{ \frac{P\phi}{(N+1) \times 64 \times 2^{2n-1} \times B} \times 10^6 - 1 \right\} \times 100$$

Table 16.4 lists examples of SCBRR settings.

Table 16.4 Bit Rates and SCBRR Settings

Bit Rate (bits/s)	P ϕ (MHz)								
	2			2.097152			2.4576		
	n	N	Error (%)	n	N	Error (%)	n	N	Error (%)
110	1	141	0.03	1	148	-0.04	1	174	-0.26
150	1	103	0.16	1	108	0.21	1	127	0.00
300	0	207	0.16	0	217	0.21	0	255	0.00
600	0	103	0.16	0	108	0.21	0	127	0.00
1200	0	51	0.16	0	54	-0.70	0	63	0.00
2400	0	25	0.16	0	26	1.14	0	31	0.00
4800	0	12	0.16	0	13	-2.48	0	15	0.00
9600	0	6	-6.99	0	6	-2.48	0	7	0.00
19200	0	2	8.51	0	2	13.78	0	3	0.00
31250	0	1	0.00	0	1	4.86	0	1	22.88
38400	0	1	-18.62	0	0	-14.67	0	1	0.00

Bit Rate (bits/s)	P ϕ (MHz)								
	6.144			7.3728			8		
	n	N	Error (%)	n	N	Error (%)	n	N	Error (%)
110	2	108	0.08	2	130	-0.07	2	141	0.03
150	2	79	0.00	2	95	0.00	2	103	0.16
300	1	159	0.00	1	191	0.00	1	207	0.16
600	1	79	0.00	1	95	0.00	1	103	0.16
1200	0	159	0.00	0	191	0.00	0	207	0.16
2400	0	79	0.00	0	95	0.00	0	103	0.16
4800	0	39	0.00	0	47	0.00	0	51	0.16
9600	0	19	0.00	0	23	0.00	0	25	0.16
19200	0	9	0.00	0	11	0.00	0	12	0.16
31250	0	5	2.40	0	6	5.33	0	7	0.00
38400	0	4	0.00	0	5	0.00	0	6	-6.99

Bit Rate (bits/s)	P ϕ (MHz)											
	9.8304			10			12			12.288		
	n	N	Error (%)	n	N	Error (%)	n	N	Error (%)	n	N	Error (%)
110	1	174	-0.26	2	177	-0.25	1	212	0.03	2	217	0.08
150	1	127	0.00	2	129	0.16	1	155	0.16	2	159	0.00
300	0	255	0.00	2	64	0.16	1	77	0.16	2	79	0.00
600	0	127	0.00	1	129	0.16	0	155	0.16	1	159	0.00
1200	0	255	0.00	1	64	0.16	0	77	0.16	1	79	0.00
2400	0	127	0.00	0	129	0.16	0	38	0.16	0	159	0.00
4800	0	63	0.00	0	64	0.16	0	19	0.16	0	79	0.00
9600	0	31	0.00	0	32	-1.36	0	9	0.16	0	39	0.00
19200	0	15	0.00	0	15	1.73	0	4	0.16	0	19	0.00
31250	0	9	-1.70	0	9	0.00	0	2	0.00	0	11	2.40
38400	0	1	0.00	0	7	1.73	0	9	-2.34	0	9	0.00

Table 16.5 indicates the maximum bit rates in asynchronous mode when the baud rate generator is used. Table 16.6 list the maximum rates for external clock input.

Table 16.5 Maximum Bit Rates for Various Frequencies with Baud Rate Generator (Asynchronous Mode)

P ϕ (MHz)	Maximum Bit Rate (bits/s)	Settings	
		n	N
2	62500	0	0
2.097152	65536	0	0
2.4576	76800	0	0
3	93750	0	0
3.6864	115200	0	0
4	125000	0	0
4.9152	153600	0	0
8	250000	0	0
9.8304	307200	0	0
12	375000	0	0
14.7456	460800	0	0
16	500000	0	0
19.6608	614400	0	0
20	625000	0	0
24	750000	0	0
24.576	768000	0	0
28.7	896875	0	0
30	937500	0	0

Table 16.6 Maximum Bit Rates with External Clock Input (Asynchronous Mode)

Pϕ (MHz)	External Input Clock (MHz)	Maximum Bit Rate (bits/s)
2	0.5000	31250
2.097152	0.5243	32768
2.4576	0.6144	38400
3	0.7500	46875
3.6864	0.9216	57600
4	1.0000	62500
4.9152	1.2288	76800
8	2.0000	125000
9.8304	2.4576	153600
12	3.0000	187500
14.7456	3.6864	230400
16	4.0000	250000
19.6608	4.9152	307200
20	5.0000	312500
24	6.0000	375000
24.576	6.1440	384000
28.7	7.1750	448436
30	7.5000	468750

16.2.9 FIFO Control Register (SCFCR)

Bit:	7	6	5	4	3	2	1	0
	RTRG1	RTRG0	TTRG1	TTRG0	MCE	TFRST	RFRST	LOOP
Initial value:	0	0	0	0	0	0	0	0
R/W:	R/W	R/W	R/W	R/W	R/W	R/W	R/W	R/W

The FIFO control register (SCFCR) resets the quantity of data in the transmit and receive FIFO registers, sets the trigger data quantity, and contains an enable bit for loop-back testing. SCFCR can always be read and written to by the CPU. It is initialized to H'00 by a reset, by the module standby function, and in standby mode.

Bits 7 and 6—Receive FIFO Data Trigger (RTRG1, RTRG0): Set the quantity of receive data which sets the receive data full (RDF) flag in the serial status register (SCSSR). The RDF flag is set to 1 when the quantity of receive data stored in the receive FIFO register (SCFRDR) exceeds the set trigger number shown below.

Bit 7: RTRG1	Bit 6: RTRG0	Receive Trigger Number
0	0	1 (Initial value)
0	1	4
1	0	8
1	1	14

Bits 5 and 4—Transmit FIFO Data Trigger (TTRG1, TTRG0): Set the quantity of remaining transmit data which sets the transmit FIFO data register empty (TDFE) flag in the serial status register (SCSSR). The TDFE flag is set to 1 when the quantity of transmit data in the transmit FIFO data register (SCFTDR) becomes less than the set trigger number shown below.

Bit 5: TTRG1	Bit 4: TTRG0	Transmit Trigger Number
0	0	8 (8)*
0	1	4 (12)
1	0	2 (14)
1	1	1 (15)

Note: * Initial value. Values in parentheses mean the number of empty bits in SCFTDR when the TDFE flag is set to 1.

Bit 3—Modem Control Enable (MCE): Enables modem control signals CTS and RTS.

Bit 3: MCE	Description
0	Modem signal disabled* (Initial value)
1	Modem signal enabled

Note: * CTS is fixed at active 0 regardless of the input value, and RTS is also fixed at 0.

Bit 2—Transmit FIFO Data Register Reset (TFRST): Disables the transmit data in the transmit FIFO data register and resets the data to the empty state.

Bit 2: TFRST	Description
0	Reset operation disabled* (Initial value)
1	Reset operation enabled

Note: * Reset is executed in a reset or in standby mode.

Bit 1—Receive FIFO Data Register Reset (RFRST): Disables the receive data in the receive FIFO data register and resets the data to the empty state.

Bit 1: RFRST	Description
0	Reset operation disabled* (Initial value)
1	Reset operation enabled

Note: * Reset is executed in a reset or in standby mode.

Bit 0—Loop-Back Test (LOOP): Internally connects the transmit output pin (TXD) and receive input pin (RXD) and enables loop-back testing.

Bit 0: LOOP	Description
0	Loop back test disabled (Initial value)
1	Loop back test enabled

16.2.10 FIFO Data Count Register (SCFDR)

SCFDR is a 16-bit register which indicates the quantity of data stored in the transmit FIFO data register (SCFTDR) and the receive FIFO data register (SCFRDR). It indicates the quantity of transmit data in SCFTDR with the upper 8 bits, and the quantity of receive data in SCFRDR with the lower 8 bits. SCFDR can always be read by the CPU.

Upper 8 Bits:	15	14	13	12	11	10	9	8
	—	—	—	T4	T3	T2	T1	T0
Initial value:	0	0	0	0	0	0	0	0
R/W:	R	R	R	R	R	R	R	R

The upper 8 bits of SCFDR indicate the quantity of non-transmitted data stored in SCFTDR. H'00 means no transmit data, and H'10 means that SCFTDR is full of transmit data.

Lower 8 Bits:	7	6	5	4	3	2	1	0
	—	—	—	R4	R3	R2	R1	R0
Initial value:	0	0	0	0	0	0	0	0
R/W:	R	R	R	R	R	R	R	R

The lower 8 bits of SCFDR indicate the quantity of receive data stored in SCFRDR. H'00 means no receive data, and H'10 means that SCFRDR full of receive data.

16.3 Operation

16.3.1 Overview

For serial communication, the SCIF has an asynchronous mode in which characters are synchronized individually. Refer to section 14.3.2, Operation in Asynchronous Mode. The SCIF has a 16-byte FIFO buffer for both transmit and receive operations, reducing the overhead of the CPU, and enabling continuous high-speed communication. Moreover, it has $\overline{\text{RTS}}$ and $\overline{\text{CTS}}$ signals as modem control signals. The transmission format is selected in the serial mode register (SCSMR), as shown in table 16.7. The SCIF clock source is selected by the combination of the CKE1 and CKE0 bits in the serial control register (SCSCR), as shown in table 16.8.

- Data length is selectable: 7 or 8 bits.
- Parity and multiprocessor bits are selectable, as is the stop bit length (1 or 2 bits). The combination of the preceding selections constitutes the communication format and character length.
- In receiving, it is possible to detect framing errors (FER), parity errors (PER), receive FIFO data full, receive data ready, and breaks.
- In transmitting, it is possible to detect transmit FIFO data empty.
- The number of stored data bytes is indicated for both the transmit and receive FIFO registers.
- An internal or external clock can be selected as the SCIF clock source.
 - When an internal clock is selected, the SCIF operates using the on-chip baud rate generator, and can output a serial clock signal with a frequency 16 times the bit rate.
 - When an external clock is selected, the external clock input must have a frequency 16 times the bit rate. (The on-chip baud rate generator is not used.)

Table 16.7 SCSMR Settings and SCIF Communication Formats

Mode	SCSMR Settings					SCIF Communication Format
	Bit 6 CHR	Bit 5 PE	Bit 3 STOP	Data Length	Parity Bit	Stop Bit Length
Asynchronous	0	0	0	8-bit	Not set	1 bit
			1			2 bits
		1	0	Set	1 bit	
			1		2 bits	
	1	0	0	7-bit	Not set	1 bit
			1			2 bits
		1	0	Set	1 bit	
			1		2 bits	

Table 16.8 SCSCR Settings and SCIF Clock Source Selection

Mode	SCSCR Settings		SCIF Transmit/Receive Clock	
	Bit 1 CKE1	Bit 0 CKE0	Clock Source	SCK Pin Function
Asynchronous mode	0	0	Internal	SCIF does not use the SCK pin
		1		Outputs a clock with a frequency 16 times the bit rate
	1	0	External	Inputs a clock with frequency 16 times the bit rate
		1		

16.3.2 Serial Operation

Transmit/Receive Formats: Table 16.9 lists the eight communication formats that can be selected. The format is selected by settings in the serial mode register (SCSMR).

Table 16.9 Serial Communication Formats

SCSMR Bits			Serial Transmit/Receive Format and Frame Length											
CHR	PE	STOP	1	2	3	4	5	6	7	8	9	10	11	12
0	0	0	START	8-bit data						STOP				
0	0	1	START	8-bit data						STOP	STOP			
0	1	0	START	8-bit data						P	STOP			
0	1	1	START	8-bit data						P	STOP	STOP		
1	0	0	START	7-bit data					STOP					
1	0	1	START	7-bit data					STOP	STOP				
1	1	0	START	7-bit data					P	STOP				
1	1	1	START	7-bit data					P	STOP	STOP			

START: Start bit
 STOP: Stop bit
 P: Parity bit

Clock: An internal clock generated by the on-chip baud rate generator or an external clock input from the SCK pin can be selected as the SCIF transmit/receive clock. The clock source is selected by bits CKE1 and CKE0 in the serial control register (SCSCR) (table 16.8).

When an external clock is input at the SCK pin, it must have a frequency equal to 16 times the desired bit rate.

When the SCIF operates on an internal clock, it can output a clock signal at the SCK pin. The frequency of this output clock is 16 times the bit rate.

Transmitting and Receiving Data (SCIF Initialization): Before transmitting or receiving, clear the TE and RE bits to 0 in the serial control register (SCSCR), then initialize the SCIF as follows.

When changing the communication format, always clear the TE and RE bits to 0 before following the procedure given below. Clearing TE to 0 initializes the transmit shift register (SCTSR). Clearing TE and RE to 0, however, does not initialize the serial status register (SCSSR), transmit FIFO data register (SCFTDR), or receive FIFO data register (SCFRDR), which retain their previous contents. Clear TE to 0 after all transmit data has been transmitted and the TEND flag in the SCSSR is set. The TE bit can be cleared to 0 during transmission, but the transmit data goes to the high impedance state after the bit is cleared to 0. Set the TFRST bit in SCFCR to 1 and reset SCFTDR before TE is set again to start transmission.

When an external clock is used, the clock should not be stopped during initialization or subsequent operation. SCIF operation becomes unreliable if the clock is stopped.

Figure 16.5 shows a sample flowchart for initializing the SCIF. The procedure for initializing the SCIF is:

1. Set the clock selection in SCSCR.
Be sure to clear bits RIE TIE, TE, and RE to 0.
When clock output is selected, the clock is output immediately after SCSCR settings are made.
2. Set the communication format in SCSMR.
3. Write a value corresponding to the bit rate into the bit rate register (SCBRR).
(Not necessary if an external clock is used.)
4. Wait at least one bit interval, then set the TE bit or RE bit in SCSCR to 1. Also set the RIE and TIE bits.
Setting the TE and RE bits enables the TxD and RxD pins to be used. When transmitting, the SCIF will go to the mark state; when receiving, it will go to the idle state, waiting for a start bit.

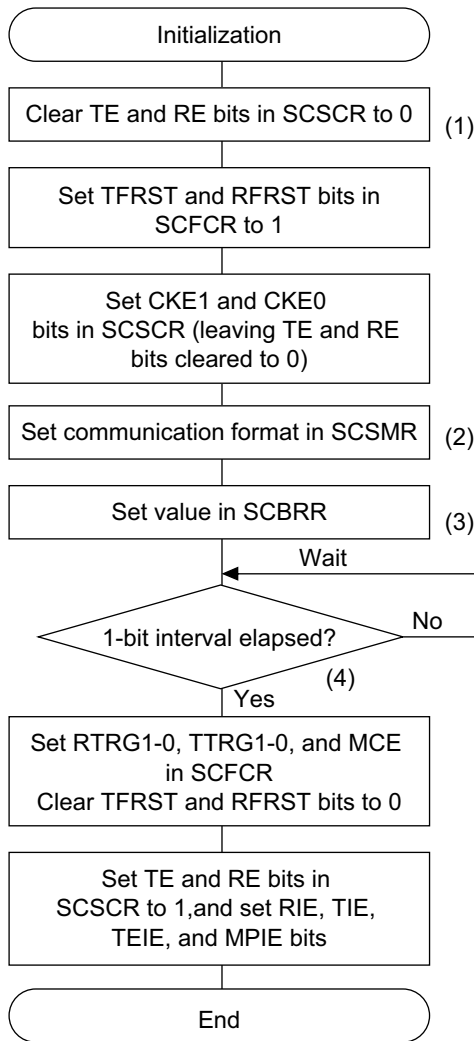

Note: Numbers in parentheses refer to steps in the preceding procedure description.

Figure 16.5 Sample Flowchart for SCIF Initialization

- Serial data transmission

Figure 16.6 shows a sample flowchart for serial transmission.

Use the following procedure for serial data transmission after enabling the SCIF for transmission.

1. SCIF status check and transmit data write:

Read serial status register (SCSSR) and check that the TDFE flag is set to 1, then write transmit data to the transmit FIFO data register (SCFTDR), read 1 from the TDFE and TEND flags, then clear these flags to 0.

The number of transmit data bytes that can be written is (16 - transmit trigger set number).

2. Serial transmission continuation procedure:

To continue serial transmission, read 1 from the TDFE flag to confirm that writing is possible, then write data to SCFTDR, and then clear the TDFE flag to 0.

3. Break output at the end of serial transmission:

To output a break in serial transmission, set the port SC data register (SCPDR) and port SC control register (SCPCR), then clear the TE bit to 0 in the serial control register (SCSCR). For information on SCPDR and SCPCR, see section 16.2.8, Bit Rate Register (SCBRR).

In steps 1 and 2, it is possible to ascertain the number of data bytes that can be written from the number of transmit data bytes in SCFTDR indicated by the upper 8 bits of the FIFO data count register (SCFDR).

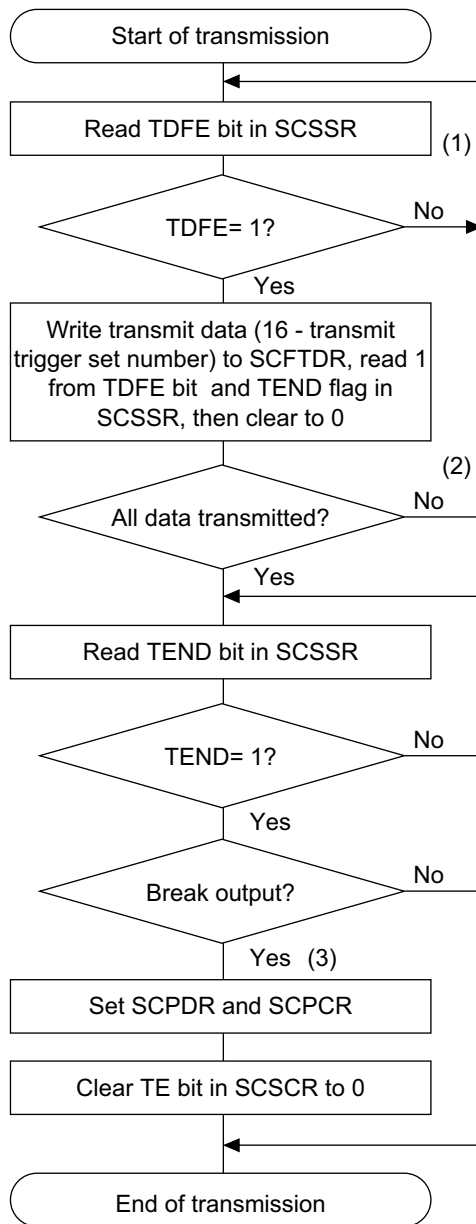

Note: Numbers in parentheses refer to steps in the preceding procedure description.

Figure 16.6 Sample Flowchart for Transmitting Serial Data

In serial transmission, the SCIF operates as described below.

1. When data is written into the transmit FIFO data register (SCFTDR), the SCIF transfers the data from SCFTDR to the transmit shift register (SCTSR) and starts transmitting. Confirm that the TDFE flag in the serial status register (SCSSR) is set to 1 before writing transmit data to SCFTDR. The number of data bytes that can be written is (16 – transmit trigger setting).
2. When data is transferred from SCFTDR to SCTSR and transmission is started, consecutive transmit operations are performed until there is no transmit data left in SCFTDR. When the number of transmit data bytes in SCFTDR falls below the transmit trigger number set in the FIFO control register (SCFCR), the TDFE flag is set. If the TIE bit in the serial control register (SCSR) is set to 1 at this time, a transmit-FIFO-data-empty interrupt (TXI) request is generated.

The serial transmit data is sent from the TxD pin in the following order.

- a. Start bit: One-bit 0 is output.
 - b. Transmit data: 8-bit or 7-bit data is output in LSB-first order.
 - c. Parity bit: One parity bit (even or odd parity) is output. (A format in which a parity bit is not output can also be selected.)
 - d. Stop bit(s): One or two 1-bits (stop bits) are output.
 - e. Mark state: 1 is output continuously until the start bit that starts the next transmission is sent.
3. The SCIF checks the SCFTDR transmit data at the timing for sending the stop bit. If data is present, the data is transferred from SCFTDR to SCTSR, the stop bit is sent, and then serial transmission of the next frame is started.

If there is no transmit data, the TEND flag in SCSSR is set to 1, the stop bit is sent, and then the line goes to the mark state in which 1 is output continuously.

Figure 16.7 shows an example of the operation for transmission.

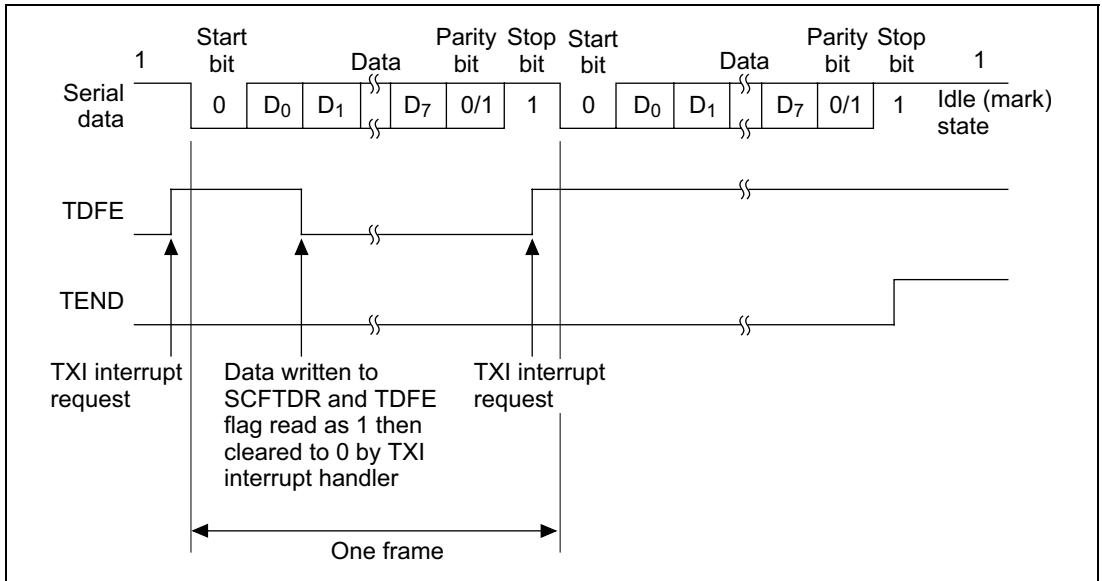

**Figure 16.7 Example of Transmit Operation
(8-Bit Data, Parity, One Stop Bit)**

- When modem control is enabled, transmission can be stopped and restarted in accordance with the $\overline{\text{CTS}}$ input value. When $\overline{\text{CTS}}$ is set to 1, if transmission is in progress, the line goes to the mark state after transmission of one frame. When $\overline{\text{CTS}}$ is set to 0, the next transmit data is output starting from the start bit.

Figure 16.8 shows an example of the operation when modem control is used.

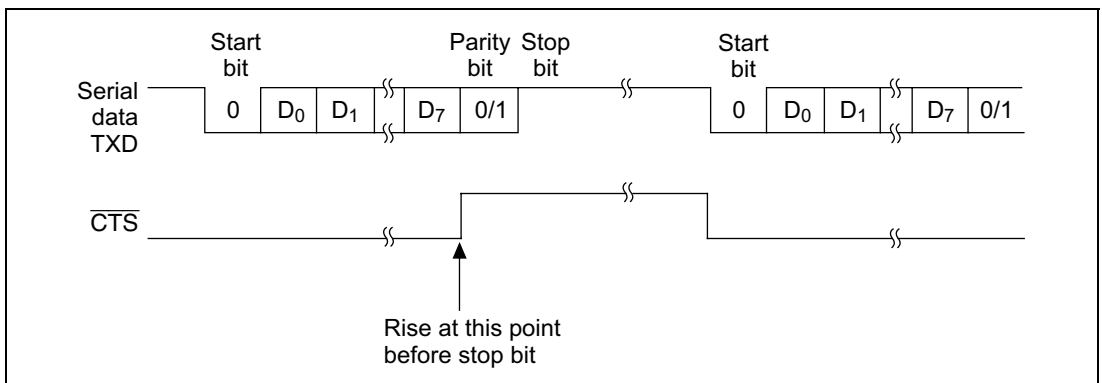

Figure 16.8 Example of Operation Using Modem Control ($\overline{\text{CTS}}$)

- Serial data reception

Figures 16.9 and 16.10 show a sample flowchart for serial reception.

Use the following procedure for serial data reception after enabling the SCIF for reception.

1. Receive error handling and break detection: Read the DR, ER, and BRK flags in SCSSR to identify any error, perform the appropriate error handling, then clear the DR, ER, and BRK flags to 0. In the case of a framing error, a break can also be detected by reading the value of the RxD pin.
2. SCIF status check and receive data read : Read the serial status register (SCSSR) and check that RDF = 1, then read the receive data in the receive FIFO data register (SCFRDR), read 1 from the RDF flag, and then clear the RDF flag to 0. The transition of the RDF flag from 0 to 1 can be identified by an RXI interrupt.
3. Serial reception continuation procedure: To continue serial reception, read at least the receive trigger set number of receive data bytes from SCFRDR, read 1 from the RDF flag, then clear the RDF flag to 0. The number of receive data bytes in SCFRDR can be ascertained by reading the lower bits of SCFDR.

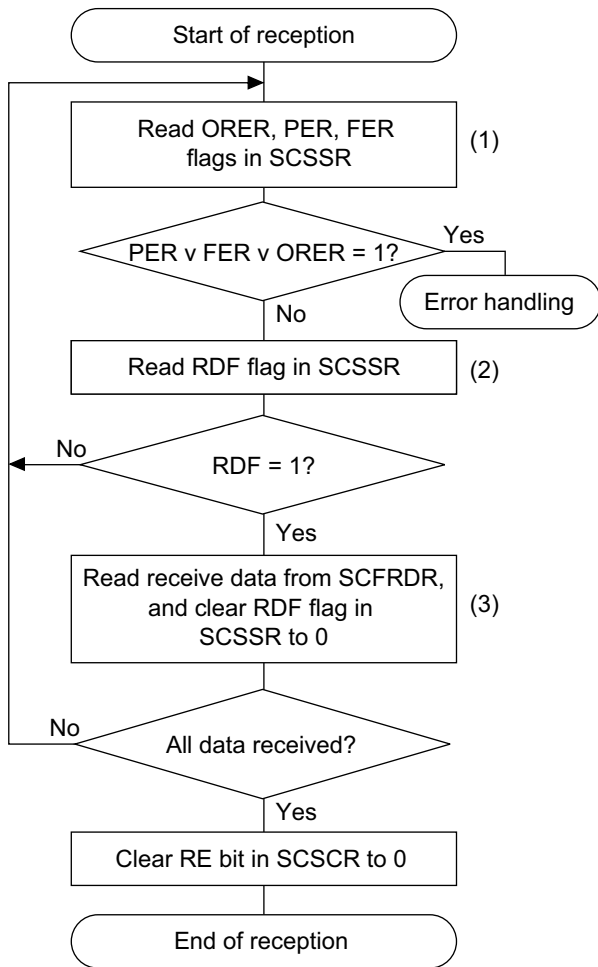

Note: Numbers in parentheses refer to steps in the preceding procedure description.

Figure 16.9 Sample Flowchart for Receiving Serial Data

1. Whether a framing error or parity error has occurred in the receive data read from SCFRDR can be ascertained from the FER and PER bits in SCSSR.
2. When a break signal is received, receive data is not transferred to SCFRDR while the BRK flag is set. However, note that the last data in SCFRDR is H'00 and the break data in which a framing error occurred is stored.

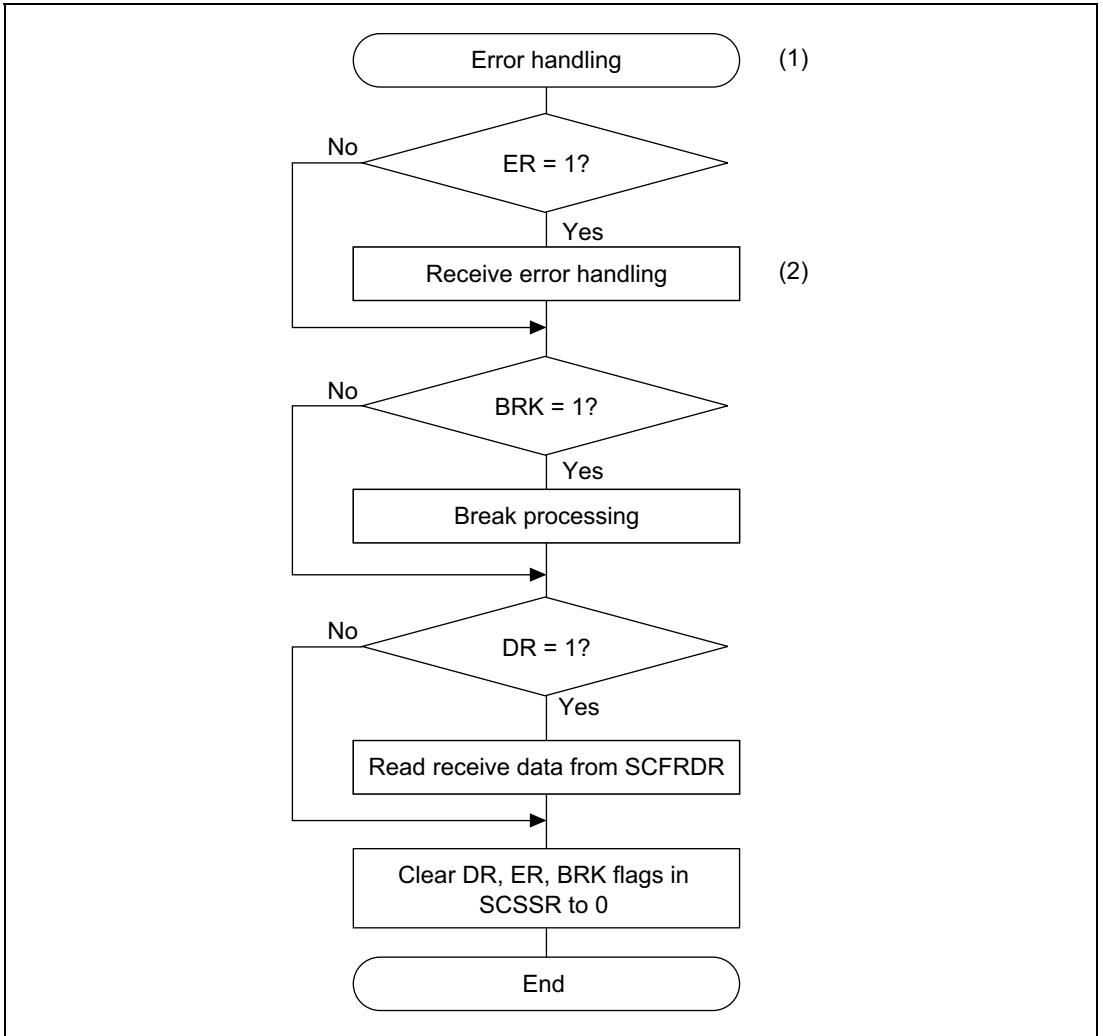

Figure 16.10 Sample Flowchart for Receiving Serial Data (cont)

In serial reception, the SCIF operates as described below.

1. The SCIF monitors the transmission line, and if a 0 start bit is detected, performs internal synchronization and starts reception.
2. The received data is stored in SCRSR in LSB-to-MSB order.
3. The parity bit and stop bit are received.
After receiving these bits, the SCIF carries out the following checks.
 - a. Stop bit check: The SCIF checks whether the stop bit is 1. If there are two stop bits, only the first is checked.
 - b. The SCIF checks whether receive data can be transferred from the receive shift register (SCRSR) to SCFRDR.
 - c. Break check: The SCIF checks that the BRK flag is 0, indicating that the break state is not set.

If all the above checks are passed, the receive data is stored in SCFRDR.

Note: Reception is not suspended when a receive error occurs.

4. If the RIE bit in SCSR is set to 1 when the RDF or DR flag changes to 1, a receive-FIFO-data-full interrupt (RXI) request is generated.
If the RIE bit in SCSR is set to 1 when the ER flag changes to 1, a receive-error interrupt (ERI) request is generated.

If the RIE bit in SCSR is set to 1 when the BRK flag changes to 1, a break reception interrupt (BRI) request is generated.

Figure 16.11 shows an example of the operation for reception.

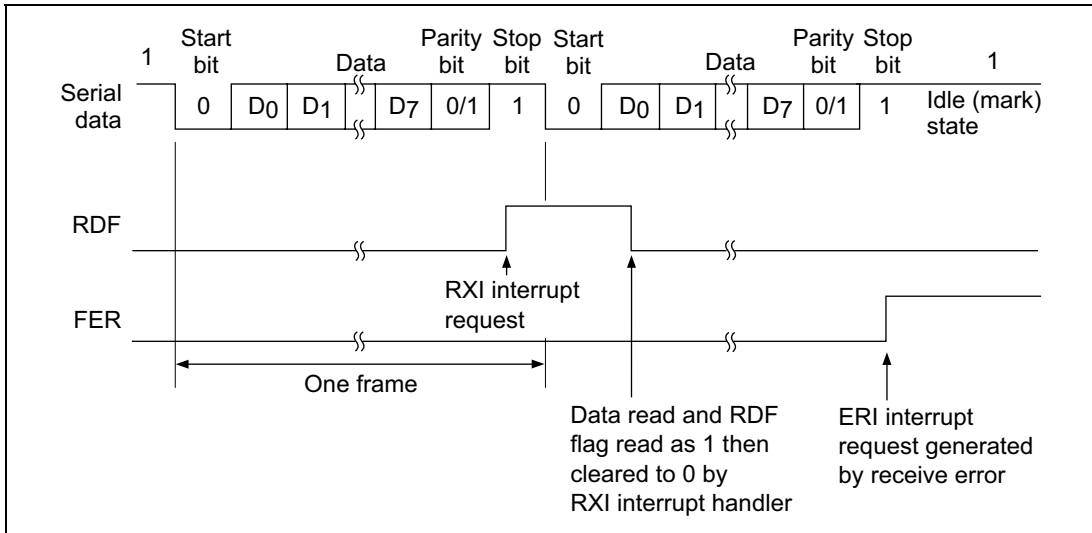

Figure 16.11 Example of SCIF Receive Operation (8-Bit Data, Parity, One Stop Bit)

- When modem control is enabled, the $\overline{\text{RTS}}$ signal is output when SCFRDR is empty. When $\overline{\text{RTS}}$ is 0, reception is possible. When $\overline{\text{RTS}}$ is 1, this indicates that SCFRDR is full and reception is not possible.

Figure 16.12 shows an example of the operation when modem control is used.

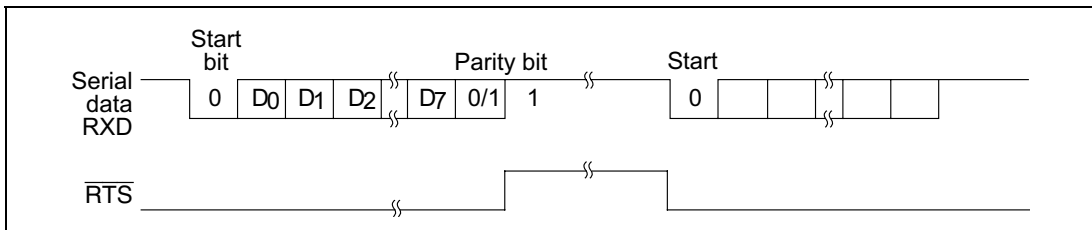

Figure 16.12 Example of Operation Using Modem Control ($\overline{\text{RTS}}$)

16.4 SCIF Interrupts

The SCIF has four interrupt sources: transmit-FIFO-data-empty (TXI), receive-error (ERI), receive-data-full (RXI), and break (BRI).

Table 16.10 shows the interrupt sources and their order of priority. The interrupt sources are enabled or disabled by means of the TIE and RIE bits in SCSCR. A separate interrupt request is sent to the interrupt controller for each of these interrupt sources.

When the TDFE flag in the serial status register (SCSSR) is set to 1, a TXI interrupt request is generated. The DMAC can be activated and data transfer performed when this interrupt is generated. When data exceeding the transmit trigger number is written to the transmit data register (SCFTDR) by the DMAC, 1 is read from the TDFE flag, after which 0 is written to it to clear it.

When the RDF flag in SCSSR is set to 1, an RXI interrupt request is generated. The DMAC can be activated and data transfer performed when the RDF flag in SCSSR is set to 1. When receive data less than the receive trigger number is read from the receive data register (SCFRDR) by the DMAC, 1 is read from the RDF flag, after which 0 is written to it to clear it.

When the ER flag in SCSSR is set to 1, an ERI interrupt request is generated.

When the BRK flag in SCSSR is set to 1, a BRI interrupt request is generated.

The TXI interrupt indicates that transmit data can be written, and the RXI interrupt indicates that there is receive data in SCFRDR.

Table 16.10 SCIF Interrupt Sources

Interrupt Source	Description	DMAC Activation	Priority on Reset Release
ERI	Interrupt initiated by receive error flag (ER)	Not possible	High
RXI	Interrupt initiated by receive data FIFO full flag (RDF) or data ready flag (DR)	Possible (RDF only)	
BRI	Interrupt initiated by break flag (BRK)	Not possible	
TXI	Interrupt initiated by transmit FIFO data empty flag (TDFE)	Possible	

See section 4, Exception Handling, for priorities and the relationship to non-SCIF interrupts.

16.5 Usage Notes

Note the following when using the SCIF.

1. SCFTDR Writing and TDFE Flag: The TDFE flag in the serial status register (SCSSR) is set when the number of transmit data bytes written in the transmit FIFO data register (SCFTDR) has fallen below the transmit trigger number set by bits TTRG1 and TTRG0 in the FIFO control register (SCFCR). After TDFE is set, transmit data up to the number of empty bytes in SCFTDR can be written, allowing efficient continuous transmission.

However, if the number of data bytes written to SCFTDR is equal to or less than the transmit trigger number, the TDFE flag will be set to 1 again even after having been cleared to 0. TDFE clearing should therefore be carried out after data exceeding the specified transmit trigger number has been written to SCFTDR.

The number of transmit data bytes in SCFTDR can be found from the upper 8 bits of the FIFO data count register (SCFDR).

2. SCFRDR Reading and RDF Flag: The RDF flag in the serial status register (SCSSR) is set when the number of receive data bytes in the receive FIFO data register (SCFRDR) has become equal to or greater than the receive trigger number set by bits RTRG1 and RTRG0 in the FIFO control register (SCFCR). After RDF is set, receive data equivalent to the trigger number can be read from SCFRDR, allowing efficient continuous reception.

However, if the number of data bytes in SCFRDR exceeds the trigger number, the RDF flag will be set to 1 again even after having been cleared to 0. RDF should therefore be cleared to 0 after being read as 1 after all the receive data has been read.

The number of receive data bytes in SCFRDR can be found from the lower 8 bits of the FIFO data count register (SCFDR).

3. Break Detection and Processing: Break signals can be detected by reading the RxD pin directly when a framing error (FER) is detected. In the break state the input from the RxD pin consists of all 0s, so the FER flag is set and the parity error flag (PER) may also be set. Note that, although transfer of receive data to SCFRDR is halted in the break state, the SCIF receiver continues to operate, so if the BRK flag is cleared to 0 it will be set to 1 again.

4. Sending a Break Signal: The I/O condition and level of the TxD pin are determined by the SCP4DT bit in the port SC data register (SCPDR) and bits SCP4MD0 and SCP4MD1 in the port SC control register (SCPCR). This feature can be used to send a break signal.

To send a break signal during serial transmission, clear the SCP4DT bit to 0 (designating low level), then set the SCP4MD0 and SCP4MD1 bits to 0 and 1, respectively, and finally clear the TE bit to 0 (halting transmission). When the TE bit is cleared to 0, the transmitter is initialized regardless of the current transmission state, and 0 is output from the TxD pin.

5. TEND Flag and TE Bit Processing: The TEND flag is set to 1 during transmission of the stop bit of the last data. Consequently, if the TE bit is cleared to 0 immediately after setting of the TEND flag has been confirmed, the stop bit will be in the process of transmission and will not be transmitted normally. Therefore, the TE bit should not be cleared to 0 for at least 0.5 serial clock cycles (or 1.5 cycles if two stop bits are used) after setting of the TEND flag is confirmed.

6. Receive Data Sampling Timing and Receive Margin: The SCIF operates on a base clock with a frequency of 16 times the transfer rate. In reception, the SCIF synchronizes internally with the fall of the start bit, which it samples on the base clock. Receive data is latched at the rising edge of the eighth base clock pulse. The timing is shown in figure 16.13.

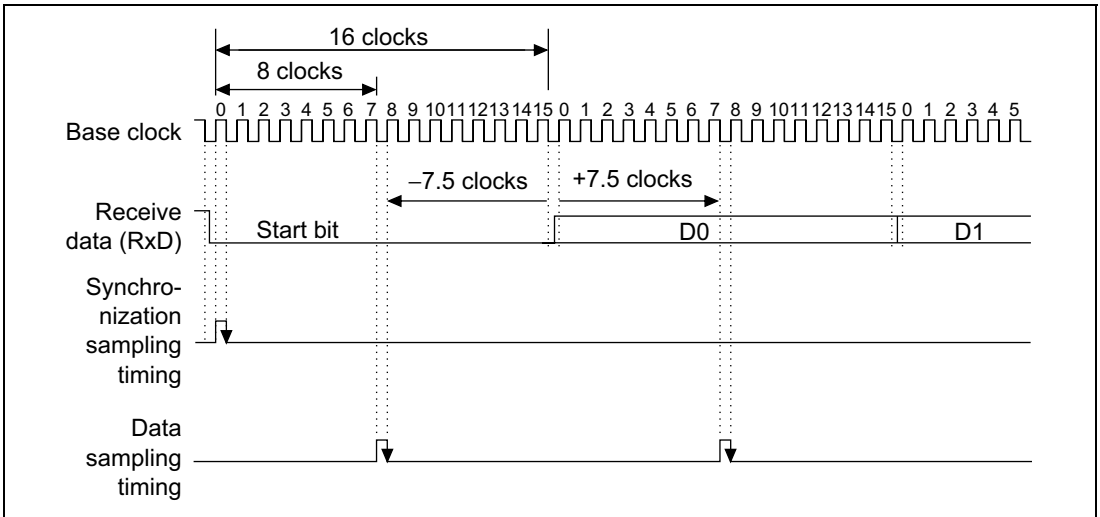

Figure 16.13 Receive Data Sampling Timing in Asynchronous Mode

The receive margin in asynchronous mode can therefore be expressed as shown in equation 1.

Equation 1:

$$M = \left[\left(0.5 - \frac{1}{2N} \right) - (L - 0.5) F - \frac{|D - 0.5|}{N} (1 + F) \right] \times 100\%$$

- Where:
- M: Receive margin (%)
 - N: Ratio of clock frequency to bit rate (N = 16)
 - D: Clock duty cycle (D = 0 to 1.0)
 - L: Frame length (L = 9 to 12)
 - F: Absolute deviation of clock frequency

From equation 1, if F = 0 and D = 0.5, the receive margin is 46.875%, as given by equation 2.

Equation 2:

When $D = 0.5$ and $F = 0$:

$$\begin{aligned} M &= (0.5 - 1/(2 \times 16)) \times 100\% \\ &= 46.875\% \end{aligned}$$

This is a theoretical value. A reasonable margin to allow in system designs is 20% to 30%.

17.1 Overview

The SH7709S has an on-chip Infrared Data Association (IrDA) interface which is based on the IrDA 1.0 system and can perform infrared communication. It also can be used as the SCIF by making register settings.

17.1.1 Features

- Conforms to the IrDA 1.0 system
- Asynchronous serial communication
 - Data length: 8 bits
 - Stop bit length: 1 bit
 - Parity bit: None
- On-chip 16-stage FIFO buffers for both transmit and receive operations
- On-chip baud rate generator with selectable bit rates
- Guard functions to protect the receiver during transmission
- Clock supply halted to reduce power consumption when not using the IrDA interface

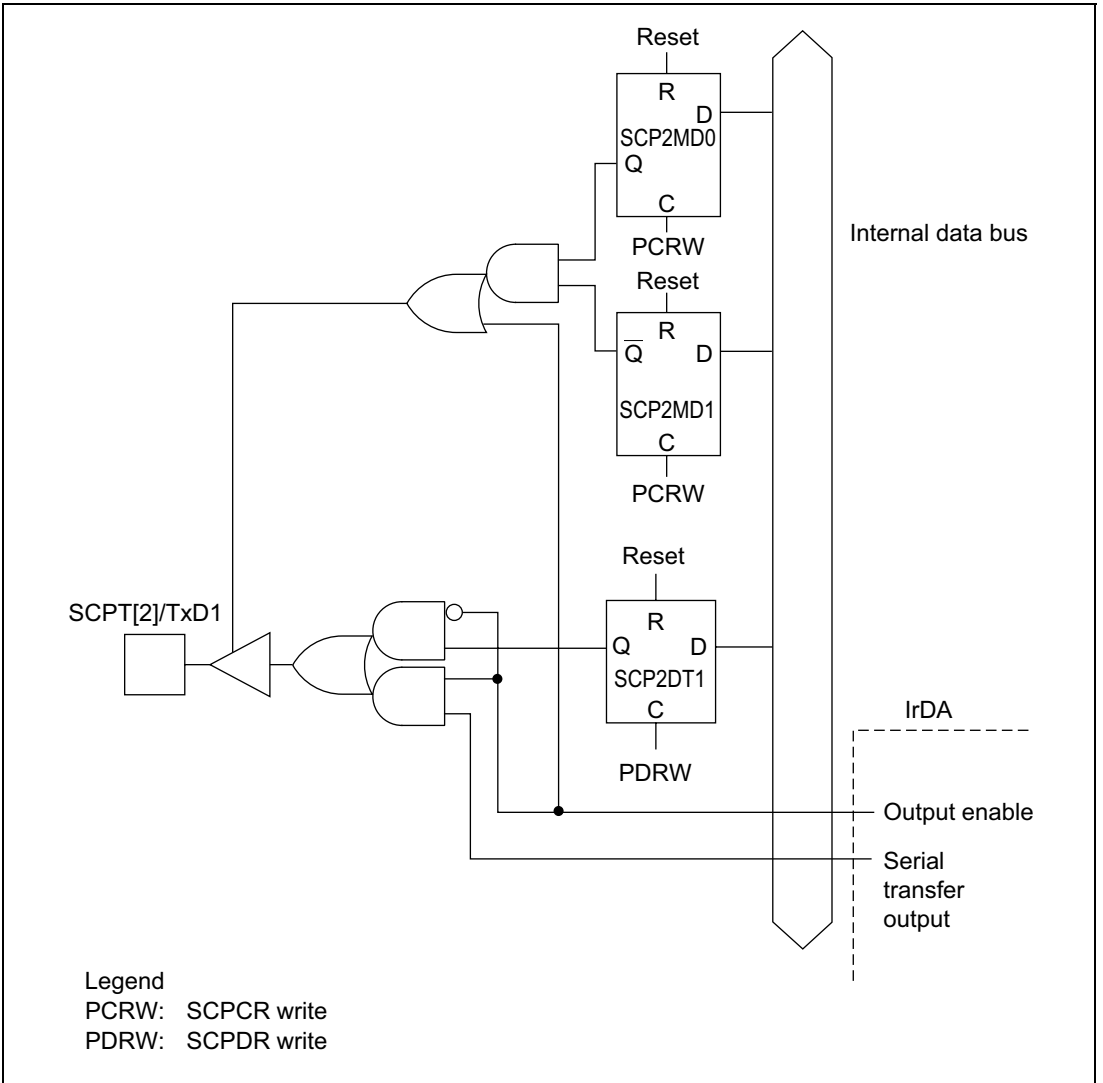

Figure 17.3 SCPT[2]/TxD1 Pin

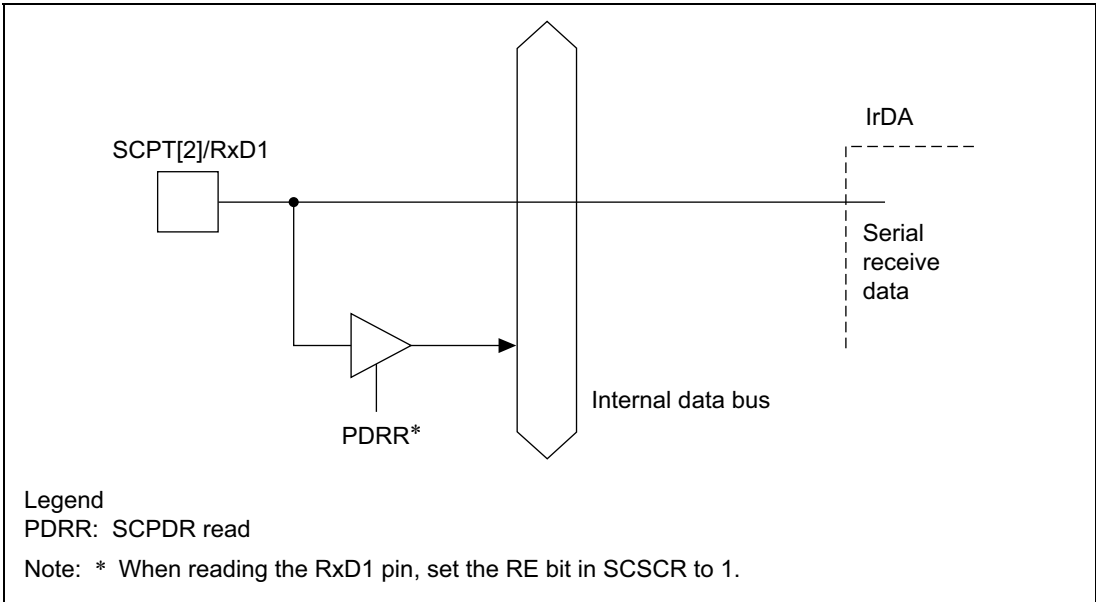

Figure 17.4 SCPT[2]/RxD1 Pin

17.1.3 Pin Configuration

The IrDA has the serial pins summarized in table 17.1.

Table 17.1 IrDA Pins

Pin Name	Signal Name	I/O	Function
Serial clock pin	SCK1	I/O	Clock I/O
Receive data pin	RxD1	Input	Receive data input
Transmit data pin	TxD1	Output	Transmit data output

Note: Clock input from the serial clock pin cannot be set in IrDA mode.

17.1.4 Register Configuration

The IrDA has the internal registers shown in table 17.2. These registers select IrDA or SCIF mode, specify the data format and a bit rate, and control the transmit and receive units.

Table 17.2 IrDA Registers

Register Name	Abbreviation	R/W	Initial Value	Address	Access Size
Serial mode register 1	SCSMR1	R/W	H'00	H'04000140 (H'A4000140)*2	8 bits
Bit rate register 1	SCBRR1	R/W	H'FF	H'04000142 (H'A4000142)*2	8 bits
Serial control register 1	SCSCR1	R/W	H'00	H'04000144 (H'A4000144)*2	8 bits
Transmit FIFO data register 1	SCFTDR1	W	—	H'04000146 (H'A4000146)*2	8 bits
Serial status register 1	SCSSR1	R/(W)*1	H'0060	H'04000148 (H'A4000148)*2	16 bits
Receive FIFO data register 1	SCFRDR1	R	Undefined	H'0400014A (H'A400014A)*2	8 bits
FIFO control register 1	SCFCR1	R/W	H'00	H'0400014C (H'A400014C)*2	8 bits
FIFO data count register 1	SCFDR1	R	H'0000	H'0400014E (H'A400014E)*2	16 bits

Notes: These registers are located in area 1 of physical space. Therefore, when the cache is on, either access these registers from the P2 area of logical space or else make an appropriate setting using the MMU so that these registers are not cached.

1. Only 0 can be written to clear the flag.
2. When address translation by the MMU does not apply, the address in parentheses should be used.

17.2 Register Description

Specifications of the registers in the IrDA are the same as those in the SCIF except for the serial mode register described below. Therefore, refer to section 16, Serial Communication Interface with FIFO (SCIF), for details of these registers.

17.2.1 Serial Mode Register (SCSMR)

Bit:	7	6	5	4	3	2	1	0
	IRMOD	ICK3	ICK2	ICK1	ICK0	PSEL	CKS1	CKS0
Initial value:	0	0	0	0	0	0	0	0
R/W:	R/W	R/W	R/W	R/W	R/W	R/W	R/W	R/W

SCSMR is an 8-bit register that selects IrDA or SCIF mode, specifies the SCIF serial communication format, selects the IrDA output pulse width, and selects the baud rate generator clock source.

This module operates as IrDA when the IRMOD bit is set to 1. At this time, bits 3 to 6 are fixed at 0. This register functions in the same way as the SCSMR register in the SCIF when the IRMOD bit is cleared to 0; therefore, this module can also operate as an SCIF.

SCSMR is initialized to H'00 by a power-on reset or manual reset, when the module is stopped by the module standby function, and in standby mode.

Bit 7—IrDA Mode (IRMOD): Selects whether this module operates as an IrDA serial communication interface or as an SCIF.

Bit 7: IRMOD	Description
--------------	-------------

0	Operates as an SCIF (Initial value)
1*	Operates as an IrDA

Note: * Do not set the CKE1 bit in the serial control register (SCSCRT) to 1 if the IRMCD bit is set to 1.

Bits 6 to 3—Ir Clock Select Bits (ICK3 to ICK0)

Bit 2—Output Pulse Width Select (PSEL): PSEL selects an IrDA output pulse width that is 3/16 of the bit length for 115 kbps or 3/16 of the bit length for the selected baud rate.

The Ir clock select bits should be set properly to fix the output pulse width at 3/16 of the bit length for 115 kbps by setting the PSEL bit to 1.

Bit 6	Bit 5	Bit 4	Bit 3	Bit 2	Description
ICK3	ICK2	ICK1	ICK0	PSEL	Pulse width: 3/16 of 115 kbps bit length
ICK3	ICK2	ICK1	ICK0	1	
Don't care	Don't care	Don't care	Don't care	0	Pulse width: 3/16 of bit length

It is necessary to generate a fixed clock pulse, IRCLK, by dividing the P ϕ clock by $1/2N + 2$ (with the value of N determined by the setting of ICK3–ICK0).

Example:

P ϕ clock: 14.7456 MHz

IRCLK: 921.6 kHz (fixed)

N: Setting of ICK3–ICK0 ($0 \leq N \leq 15$)

$$N \geq \frac{P\phi}{2 \times IRCLK} - 1 \geq 7$$

Accordingly, N is 7.

Bits 1 and 0—Clock Select 1 and 0 (CKS1, CKS0): Select the internal baud rate generator clock source. P ϕ , P ϕ /4, P ϕ /16, or P ϕ /64 can be selected by setting the CKS1 and CKS0 bits.

Refer to section 14.2.9, Bit Rate Register (SCBRR), for the relationship between the clock source, the bit rate register set value, and the baud rate.

Bit 1: CKS1	Bit 0: CKS0	Description
0	0	P ϕ clock (Initial value)
0	1	P ϕ /4 clock
1	0	P ϕ /16
1	1	P ϕ /64

Note: P ϕ : Peripheral clock

17.3 Operation Description

The IrDA module can perform infrared communication conforming to IrDA 1.0 by connecting infrared transmit/receive units. The serial communication interface unit includes a 16-stage FIFO buffer in the transmit unit and the receive unit, allowing CPU overhead to be reduced and continuous high-speed communication to be performed. This module also supports DMAC data transfer. The IrDA module differs from the SCIF described in section 16, Serial Communication Interface with FIFO (SCIF) in that it does not include modem control signals RTS and CTS.

Refer to section 16.3, Operation, for SCIF mode operation.

17.3.1 Overview

The IrDA module modifies TxD/RxD transmit/receive data waveforms to satisfy the IrDA 1.0 specification for infrared communication.

In the IrDA 1.0 specification, communication is first performed at a speed of 9600 bps, and the communication speed is changed. However, the communication rate cannot be automatically changed in this module, so the communication speed should be confirmed, and the appropriate speed set for this module by software.

Note: In IrDA mode, reception cannot be performed when the TE bit in the serial control register (SCSCR) is set to 1 (enabling transmission). When performing reception, clear the TE bit in SCSCR to 0.

As the SH7709S's RxD1 pin is active-high in IrDA mode, a (Schmidt) inverter must be inserted when connecting an active-low IrDA module.

The RxD1 pin is active-low in SCIF mode.

17.3.2 Transmitting

In the case of a serial output signal (UART frame) from the SCIF, its waveforms are modified and the signal is converted into the IR frame serial output signal by the IrDA module, as shown in figure 17.5.

When serial data is 0, a pulse of 3/16 the IR frame bit width is generated and output. When serial data is 1, no pulse is output.

An infrared LED is driven by this signal demodulated to 3/16 width.

17.3.3 Receiving

Received 3/16 IR frame bit-width pulses are demodulated and converted to a UART frame, as shown in figure 17.5.

Demodulation to 0 is performed for pulse output, and demodulation to 1 is performed for no pulse output.

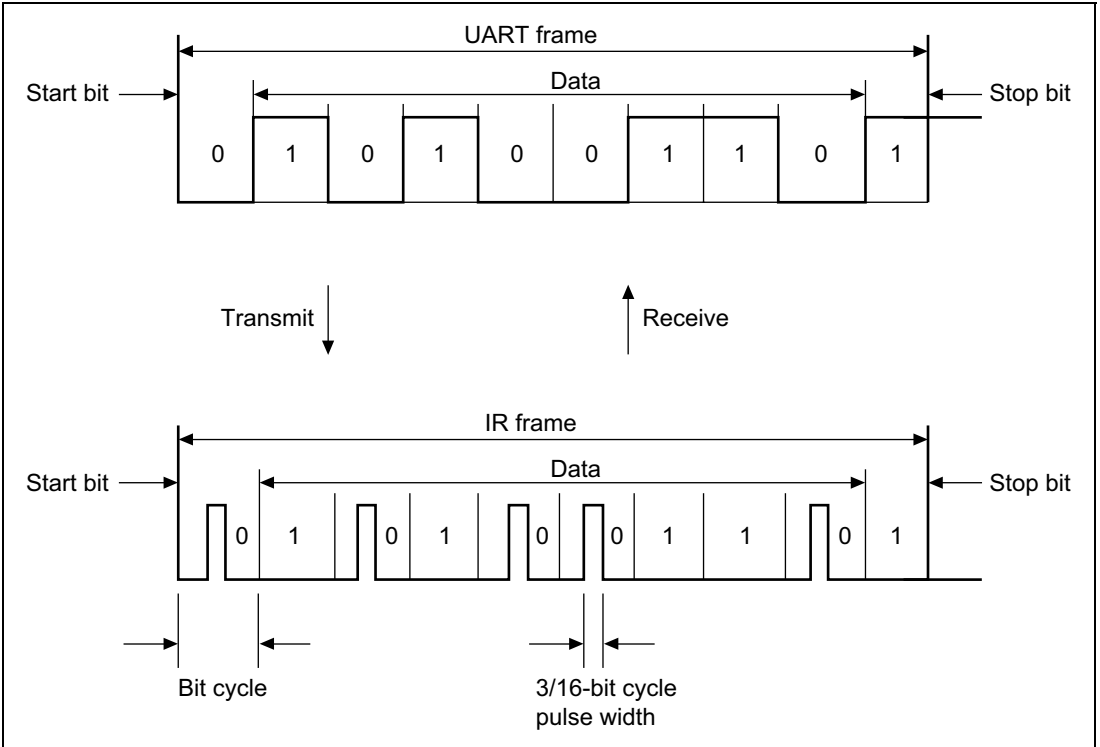

Figure 17.5 Transmit/Receive Operation

Section 18 Pin Function Controller

18.1 Overview

The pin function controller (PFC) is composed of registers for selecting the function of multiplexed pins and the input/output direction. The pin function and input/output direction can be selected for each pin individually without regard to the operating mode of the chip. Table 18.1 lists the multiplexed pins.

Table 18.1 List of Multiplexed Pins

Port	Port Function (Related Module)	Other Function (Related Module)
A	PTA7 input/output (port)	D23 input/output (data bus)
A	PTA6 input/output (port)	D22 input/output (data bus)
A	PTA5 input/output (port)	D21 input/output (data bus)
A	PTA4 input/output (port)	D20 input/output (data bus)
A	PTA3 input/output (port)	D19 input/output (data bus)
A	PTA2 input/output (port)	D18 input/output (data bus)
A	PTA1 input/output (port)	D17 input/output (data bus)
A	PTA0 input/output (port)	D16 input/output (data bus)
B	PTB7 input/output (port)	D31 input/output (data bus)
B	PTB6 input/output (port)	D30 input/output (data bus)
B	PTB5 input/output (port)	D29 input/output (data bus)
B	PTB4 input/output (port)	D28 input/output (data bus)
B	PTB3 input/output (port)	D27 input/output (data bus)
B	PTB2 input/output (port)	D26 input/output (data bus)
B	PTB1 input/output (port)	D25 input/output (data bus)
B	PTB0 input/output (port)	D24 input/output (data bus)
C	PTC7 input/output (port)/PINT7 input (INTC)	$\overline{\text{MCS7}}$ output (BSC)
C	PTC6 input/output (port)/PINT6 input (INTC)	$\overline{\text{MCS6}}$ output (BSC)
C	PTC5 input/output (port)/PINT5 input (INTC)	$\overline{\text{MCS5}}$ output (BSC)
C	PTC4 input/output (port)/PINT4 input (INTC)	$\overline{\text{MCS4}}$ output (BSC)
C	PTC3 input/output (port)/PINT3 input (INTC)	$\overline{\text{MCS3}}$ output (BSC)
C	PTC2 input/output (port)/PINT2 input (INTC)	$\overline{\text{MCS2}}$ output (BSC)
C	PTC1 input/output (port)/PINT1 input (INTC)	$\overline{\text{MCS1}}$ output (BSC)

Port	Port Function (Related Module)	Other Function (Related Module)
C	PTC0 input/output (port)/PINT0 input (INTC)	$\overline{MCS0}$ output (BSC)
D	PTD7 input/output (port)	DACK1 output (DMAC)
D	PTD6 input (port)	$\overline{DREQ1}$ input (DMAC)
D	PTD5 input/output (port)	DACK0 output (DMAC)
D	PTD4 input (port)	$\overline{DREQ0}$ input (DMAC)
D	PTD3 input/output (port)	\overline{WAKEUP} output (WTC)
D	PTD2 input/output (port)	$\overline{RESETOUT}$ output
D	PTD1 input/output (port)	DRAK0 output (DMAC)
D	PTD0 input/output (port)	DRAK1 output (DMAC)
E	PTE7 input/output (port)	$\overline{AUDSYNC}$ output (AUD)
E	PTE6 input/output (port)	—
E	PTE5 input/output (port)	$\overline{CE2B}$ output (PCMCIA)
E	PTE4 input/output (port)	$\overline{CE2A}$ output (PCMCIA)
E	PTE3 input/output (port)	—
E	PTE2 input/output (port)	$\overline{RAS3U}$ output (BSC)
E	PTE1 input/output (port)	—
E	PTE0 input/output (port)	TDO output (UDI)
F	PTF7 input (port)/PINT15 input (INTC)	\overline{TRST} input (AUD, UDI)
F	PTF6 input (port)/PINT14 input (INTC)	TMS input (UDI)
F	PTF5 input (port)/PINT13 input (INTC)	TD1 input (UDI)
F	PTF4 input (port)/PINT12 input (INTC)	TCK input (UDI)
F	PTF3 input (port)/PINT11 input (INTC)	$\overline{IRLS3}$ input (INTC)
F	PTF2 input (port)/PINT10 input (INTC)	$\overline{IRLS2}$ input (INTC)
F	PTF1 input (port)/PINT9 input (INTC)	$\overline{IRLS1}$ input (INTC)
F	PTF0 input (port)/PINT8 input (INTC)	$\overline{IRLS0}$ input (INTC)
G	PTG7 input (port)	$\overline{IOIS16}$ input (PCMCIA)
G	PTG6 input (port)	$\overline{ASEMD0}$ input (AUD, UDI)
G	PTG5 input (port)	$\overline{ASEBRKAK}$ output (AUD)
G	PTG4 input (port)	CKIO2 output (CPG)
G	PTG3 input (port)	AUDATA3 output (AUD)
G	PTG2 input (port)	AUDATA2 output (AUD)

Port	Port Function (Related Module)	Other Function (Related Module)
G	PTG1 input (port)	AUDATA1 output (AUD)
G	PTG0 input (port)	AUDATA0 output (AUD)
H	PTH7 input/output (port)	TCLK input/output (TMU)
H	PTH6 input (port)	AUDCK input (AUD)
H	PTH5 input (port)	ADTRG input (ADC)
H	PTH4 input (port)/IRQ4 input (INTC)	IRQ4 input (INTC)
H	PTH3 input (port)/IRQ3 input (INTC)	IRQ3 input (INTC)
H	PTH2 input (port)/IRQ2 input (INTC)	IRQ2 input (INTC)
H	PTH1 input (port)/IRQ1 input (INTC)	IRQ1 input (INTC)
H	PTH0 input (port)/IRQ0 input (INTC)	IRQ0 input (INTC)
J	PTJ7 input/output (port)	STATUS1 output (CPG)
J	PTJ6 input/output (port)	STATUS0 output (CPG)
J	PTJ5 input/output (port)	—
J	PTJ4 input/output (port)	—
J	PTJ3 input/output (port)	CASU output (BSC)
J	PTJ2 input/output (port)	CASL output (BSC)
J	PTJ1 input/output (port)	—
J	PTJ0 input/output (port)	RAS3L output (BSC)
K	PTK7 input/output (port)	WE3 output (BSC)/DQMUU output (BSC)/ICIOWR output (BSC)
K	PTK6 input/output (port)	WE2 output (BSC)/DQMUL output (BSC)/ICIORD output (BSC)
K	PTK5 input/output (port)	CKE output (BSC)
K	PTK4 input/output (port)	BS output (BSC)
K	PTK3 input/output (port)	CS5 output (BSC)/CE1A output (BSC)
K	PTK2 input/output (port)	CS4 output (BSC)
K	PTK1 input/output (port)	CS3 output (BSC)
K	PTK0 input/output (port)	CS2 output (BSC)
L	PTL7 input (port)	AN7 input (ADC)/DA0 output (DAC)
L	PTL6 input (port)	AN6 input (ADC)/DA1 output (DAC)
L	PTL5 input (port)	AN5 input (ADC)

Port	Port Function (Related Module)	Other Function (Related Module)
L	PTL4 input (port)	AN4 input (ADC)
L	PTL3 input (port)	AN3 input (ADC)
L	PTL2 input (port)	AN2 input (ADC)
L	PTL1 input (port)	AN1 input (ADC)
L	PTL0 input (port)	AN0 input (ADC)
SCPT	SCPT7 input (port)/IRQ5 input (INTC)	$\overline{\text{CTS2}}$ input (UART ch 3)/IRQ5 input (INTC)
SCPT	SCPT6 input/output (port)	$\overline{\text{RTS2}}$ output (UART ch 3)
SCPT	SCPT5 input/output (port)	SCK2 input/output (UART ch 3)
SCPT	SCPT4 input (port)	RxD2 input (UART ch 3)
	SCPT4 output (port)	TxD2 output (UART ch 3)
SCPT	SCPT3 input/output (port)	SCK1 input/output (UART ch 2)
SCPT	SCPT2 input (port)	RxD1 input (UART ch 2)
	SCPT2 output (port)	TxD1 output (UART ch 2)
SCPT	SCPT1 input/output (port)	SCK0 input/output (UART ch 1)
SCPT	SCPT0 input (port)	RxD0 input (UART ch 1)
	SCPT0 output (port)	TxD0 output (UART ch 1)

Note: SCPT0, SCPT2, and SCPT4 have the same data register to be accessed although they have different input pins and output pins.

18.2 Register Configuration

Table 18.2 summarizes the registers of the pin function controller.

Table 18.2 Pin Function Controller Registers

Name	Abbreviation	R/W	Initial Value	Address	Access Size
Port A control register	PACR	R/W	H'0000	H'04000100 (H'A4000100)*	16
Port B control register	PBCR	R/W	H'0000	H'04000102 (H'A4000102)*	16
Port C control register	PCCR	R/W	H'AAAA	H'04000104 (H'A4000104)*	16
Port D control register	PDCR	R/W	H'AA8A	H'04000106 (H'A4000106)*	16
Port E control register	PECR	R/W	H'AAAA/H'2AA8	H'04000108 (H'A4000108)*	16
Port F control register	PFCR	R/W	H'AAAA/H'00AA	H'0400010A (H'A400010A)*	16
Port G control register	PGCR	R/W	H'AAAA/H'A200	H'0400010C (H'A400010C)*	16
Port H control register	PHCR	R/W	H'AAAA/H'8AAA	H'0400010E (H'A400010E)*	16
Port J control register	PJCR	R/W	H'0000	H'04000110 (H'A4000110)*	16
Port K control register	PKCR	R/W	H'0000	H'04000112 (H'A4000112)*	16
Port L control register	PLCR	R/W	H'0000	H'04000114 (H'A4000114)*	16
SC port control register	SCPCR	R/W	H'A888	H'04000116 (H'A4000116)*	16

Notes: 1. The initial value of the port E, F, G, and H control registers depends on the state of the $\overline{\text{ASEMD0}}$ pin.

If a low level is input at the $\overline{\text{ASEMD0}}$ pin while the $\overline{\text{RESETP}}$ pin is asserted, ASE mode is entered; if a high level is input, normal mode is entered. See section 22, User Debugging Interface (UDI), for more information on the UDI.

2. These registers are located in area 1 of physical space. Therefore, when the cache is on, either access these registers from the P2 area of logical space or else make an appropriate setting using the MMU so that these registers are not cached.

* When address translation by the MMU does not apply, the address in parentheses should be used.

18.3 Register Descriptions

18.3.1 Port A Control Register (PACR)

Bit:	15	14	13	12	11	10	9	8	7	6	5	4	3	2	1	0
	PA7 MD1	PA7 MD0	PA6 MD1	PA6 MD0	PA5 MD1	PA5 MD0	PA4 MD1	PA4 MD0	PA3 MD1	PA3 MD0	PA2 MD1	PA2 MD0	PA1 MD1	PA1 MD0	PA0 MD1	PA0 MD0
Initial value:	0	0	0	0	0	0	0	0	0	0	0	0	0	0	0	0
R/W:	R/W	R/W	R/W	R/W	R/W	R/W	R/W	R/W	R/W	R/W	R/W	R/W	R/W	R/W	R/W	R/W

The port A control register (PACR) is a 16-bit readable/writable register that selects the pin functions. PACR is initialized to H'0000 by a power-on reset, but is not initialized by a manual reset, in standby mode, or in sleep mode.

Bits 15 and 14—PA7 Mode 1 and 0 (PA7MD1, PA7MD0)

Bits 13 and 12—PA6 Mode 1 and 0 (PA6MD1, PA6MD0)

Bits 11 and 10—PA5 Mode 1 and 0 (PA5MD1, PA5MD0)

Bits 9 and 8—PA4 Mode 1 and 0 (PA4MD1, PA4MD0)

Bits 7 and 6—PA3 Mode 1 and 0 (PA3MD1, PA3MD0)

Bits 5 and 4—PA2 Mode 1 and 0 (PA2MD1, PA2MD0)

Bits 3 and 2—PA1 Mode 1 and 0 (PA1MD1, PA1MD0)

Bits 1 and 0—PA0 Mode 1 and 0 (PA0MD1, PA0MD0)

These bits select the pin functions and perform input pull-up MOS control.

Bit (2n + 1) Bit 2n

PA _n MD1	PA _n MD0	Pin Function
0	0	Other function (see table 18.1) (Initial value)
0	1	Port output
1	0	Port input (Pull-up MOS: on)
1	1	Port input (Pull-up MOS: off)

(n = 0 to 7)

18.3.2 Port B Control Register (PBCR)

Bit:	15	14	13	12	11	10	9	8	7	6	5	4	3	2	1	0
	PB7 MD1	PB7 MD0	PB6 MD1	PB6 MD0	PB5 MD1	PB5 MD0	PB4 MD1	PB4 MD0	PB3 MD1	PB3 MD0	PB2 MD1	PB2 MD0	PB1 MD1	PB1 MD0	PB0 MD1	PB0 MD0
Initial value:	0	0	0	0	0	0	0	0	0	0	0	0	0	0	0	0
R/W:	R/W	R/W	R/W	R/W	R/W	R/W	R/W	R/W	R/W	R/W	R/W	R/W	R/W	R/W	R/W	R/W

The port B control register (PBCR) is a 16-bit readable/writable register that selects the pin functions. PBCR is initialized to H'0000 by a power-on reset, but is not initialized by a manual reset, in standby mode, or in sleep mode.

Bits 15 and 14—PB7 Mode 1 and 0 (PB7MD1, PB7MD0)

Bits 13 and 12—PB6 Mode 1 and 0 (PB6MD1, PB6MD0)

Bits 11 and 10—PB5 Mode 1 and 0 (PB5MD1, PB5MD0)

Bits 9 and 8—PB4 Mode 1 and 0 (PB4MD1, PB4MD0)

Bits 7 and 6—PB3 Mode 1 and 0 (PB3MD1, PB3MD0)

Bits 5 and 4—PB2 Mode 1 and 0 (PB2MD1, PB2MD0)

Bits 3 and 2—PB1 Mode 1 and 0 (PB1MD1, PB1MD0)

Bits 1 and 0—PB0 Mode 1 and 0 (PB0MD1, PB0MD0)

These bits select the pin functions and perform input pull-up MOS control.

Bit (2n + 1)	Bit 2n	Pin Function
PBnMD1	PBnMD0	Pin Function
0	0	Other function (see table 18.1) (Initial value)
0	1	Port output
1	0	Port input (Pull-up MOS: on)
1	1	Port input (Pull-up MOS: off)

(n = 0 to 7)

18.3.3 Port C Control Register (PCCR)

Bit: 15 14 13 12 11 10 9 8 7 6 5 4 3 2 1 0

PC7 MD1	PC7 MD0	PC6 MD1	PC6 MD0	PC5 MD1	PC5 MD0	PC4 MD1	PC4 MD0	PC3 MD1	PC3 MD0	PC2 MD1	PC2 MD0	PC1 MD1	PC1 MD0	PC0 MD1	PC0 MD0
------------	------------	------------	------------	------------	------------	------------	------------	------------	------------	------------	------------	------------	------------	------------	------------

Initial value: 1 0 1 0 1 0 1 0 1 0 1 0 1 0 1 0

R/W: R/W R/W R/W R/W R/W R/W R/W R/W R/W R/W R/W R/W R/W R/W R/W R/W

The port C control register (PCCR) is a 16-bit readable/writable register that selects the pin functions. PCCR is initialized to H'AAAA by a power-on reset, but is not initialized by a manual reset, in standby mode, or in sleep mode.

Bits 15 and 14—PC7 Mode 1 and 0 (PC7MD1, PC7MD0)

Bits 13 and 12—PC6 Mode 1 and 0 (PC6MD1, PC6MD0)

Bits 11 and 10—PC5 Mode 1 and 0 (PC5MD1, PC5MD0)

Bits 9 and 8—PC4 Mode 1 and 0 (PC4MD1, PC4MD0)

Bits 7 and 6—PC3 Mode 1 and 0 (PC3MD1, PC3MD0)

Bits 5 and 4—PC2 Mode 1 and 0 (PC2MD1, PC2MD0)

Bits 3 and 2—PC1 Mode 1 and 0 (PC1MD1, PC1MD0)

Bits 1 and 0—PC0 Mode 1 and 0 (PC0MD1, PC0MD0)

These bits select the pin functions and perform input pull-up MOS control.

Bit (2n + 1) Bit 2n

PCnMD1	PCnMD0	Pin Function
0	0	Other function (see table 18.1)
0	1	Port output
1	0	Port input (Pull-up MOS: on) (Initial value)
1	1	Port input (Pull-up MOS: off)

(n = 0 to 7)

18.3.4 Port D Control Register (PDCR)

Bit:	15	14	13	12	11	10	9	8	7	6	5	4	3	2	1	0
	PD7 MD1	PD7 MD0	PD6 MD1	PD6 MD0	PD5 MD1	PD5 MD0	PD4 MD1	PD4 MD0	PD3 MD1	PD3 MD0	PD2 MD1	PD2 MD0	PD1 MD1	PD1 MD0	PD0 MD1	PD0 MD0
Initial value:	1	0	1	0	1	0	1	0	1	0	0	0	1	0	1	0
R/W:	R/W	R/W	R/W	R/W	R/W	R/W	R/W	R/W	R/W	R/W	R/W	R/W	R/W	R/W	R/W	R/W

The port D control register (PDCR) is a 16-bit readable/writable register that selects the pin functions. PDCR is initialized to H'AA8A by a power-on reset, but is not initialized by a manual reset, in standby mode, or in sleep mode.

Bits 15 and 14—PD7 Mode 1 and 0 (PD7MD1, PD7MD0)

Bits 11 and 10—PD5 Mode 1 and 0 (PD5MD1, PD5MD0)

Bits 7 and 6—PD3 Mode 1 and 0 (PD3MD1, PD3MD0)

Bits 5 and 4—PD2 Mode 1 and 0 (PD2MD1, PD2MD0)

Bits 3 and 2—PD1 Mode 1 and 0 (PD1MD1, PD1MD0)

Bits 1 and 0—PD0 Mode 1 and 0 (PD0MD1, PD0MD0)

These bits select the pin functions and perform input pull-up MOS control.

Bit (2n + 1) Bit 2n

PDnMD1	PDnMD0	Pin Function	
0	0	Other function (see table 18.1)	(Initial value) (n = 2)
0	1	Port output	
1	0	Port input (Pull-up MOS: on)	(Initial value) (n = 0, 1, 3, 5, 7)
1	1	Port input (Pull-up MOS: off)	

(n = 0 to 3, 5, 7)

Bits 13 and 12—PD6 Mode 1 and 0 (PD6MD1, PD6MD0)

Bits 9 and 8—PD4 Mode 1 and 0 (PD4MD1, PD4MD0)

These bits select the pin functions and perform input pull-up MOS control.

Bit (2n + 1) Bit 2n

PDnMD1	PDnMD0	Pin Function	
0	0	Other function (see table 18.1)	
0	1	Reserved	
1	0	Port input (Pull-up MOS: on)	(Initial value)
1	1	Port input (Pull-up MOS: off)	

(n = 4, 6)

18.3.5 Port E Control Register (PECR)

Bit:	15	14	13	12	11	10	9	8	7	6	5	4	3	2	1	0
	PE7 MD1	PE7 MD0	PE6 MD1	PE6 MD0	PE5 MD1	PE5 MD0	PE4 MD1	PE4 MD0	PE3 MD1	PE3 MD0	PE2 MD1	PE2 MD0	PE1 MD1	PE1 MD0	PE0 MD1	PE0 MD0
Initial value:	1/0	0	1	0	1	0	1	0	1	0	1	0	1	0	1/0	0
R/W:	R/W	R/W	R/W	R/W	R/W	R/W	R/W	R/W	R/W	R/W	R/W	R/W	R/W	R/W	R/W	R/W

The port E control register (PECR) is a 16-bit readable/writable register that selects the pin functions. PECCR is initialized to H'AAAA ($\overline{ASEMD0} = 1$) or H'2AA8 ($\overline{ASEMD0} = 0$) by a power-on reset, but is not initialized by a manual reset, in software standby mode, or in sleep mode.

Bits 15 and 14—PE7 Mode 1 and 0 (PE7MD1, PE7MD0)

Bits 13 and 12—PE6 Mode 1 and 0 (PE6MD1, PE6MD0)

Bits 11 and 10—PE5 Mode 1 and 0 (PE5MD1, PE5MD0)

Bits 9 and 8—PE4 Mode 1 and 0 (PE4MD1, PE4MD0)

Bits 7 and 6—PE3 Mode 1 and 0 (PE3MD1, PE3MD0)

Bits 5 and 4—PE2 Mode 1 and 0 (PE2MD1, PE2MD0)

Bits 3 and 2—PE1 Mode 1 and 0 (PE1MD1, PE1MD0)

Bits 1 and 0—PE0 Mode 1 and 0 (PE0MD1, PE0MD0)

These bits select the pin functions and perform input pull-up MOS control.

Bit (2n + 1) Bit 2n

PE _n MD1	PE _n MD0	Pin Function
0	0	Reserved (n = 0, 7) (see table 18.1) (Initial value) ($\overline{ASEMD0} = 0$)
0	1	Port output
1	0	Port input (Pull-up MOS: on) (Initial value) ($\overline{ASEMD0} = 1$)
1	1	Port input (Pull-up MOS: off)

(n = 0, 7)

Bit (2n + 1) Bit 2n

PE _n MD1	PE _n MD0	Pin Function
0	0	Other function (n = 2, 4, 5) (see table 18.1), Reserved (n = 1, 3, 6)
0	1	Port output
1	0	Port input (Pull-up MOS: on) (Initial value)
1	1	Port input (Pull-up MOS: off)

(n = 1 to 6)

18.3.6 Port F Control Register (PFCR)

Bit:	15	14	13	12	11	10	9	8	7	6	5	4	3	2	1	0
	PF7 MD1	PF7 MD0	PF6 MD1	PF6 MD0	PF5 MD1	PF5 MD0	PF4 MD1	PF4 MD0	PF3 MD1	PF3 MD0	PF2 MD1	PF2 MD0	PF1 MD1	PF1 MD0	PF0 MD1	PF0 MD0
Initial value:	1/0	0	1/0	0	1/0	0	1/0	0	1	0	1	0	1	0	1	0
R/W:	R/W	R/W	R/W	R/W	R/W	R/W	R/W	R/W	R/W	R/W	R/W	R/W	R/W	R/W	R/W	R/W

The port F control register (PFCR) is a 16-bit readable/writable register that selects the pin functions. PFCR is initialized to H'AAAA (ASEMD0 = 1) or H'00AA (ASEMD0 = 0) by a power-on reset, but is not initialized by a manual reset, in standby mode, or in sleep mode.

Bits 15 and 14—PF7 Mode 1 and 0 (PF7MD1, PF7MD0)

Bits 13 and 12—PF6 Mode 1 and 0 (PF6MD1, PF6MD0)

Bits 11 and 10—PF5 Mode 1 and 0 (PF5MD1, PF5MD0)

Bits 9 and 8—PF4 Mode 1 and 0 (PF4MD1, PF4MD0)

Bits 7 and 6—PF3 Mode 1 and 0 (PF3MD1, PF3MD0)

Bits 5 and 4—PF2 Mode 1 and 0 (PF2MD1, PF2MD0)

Bits 3 and 2—PF1 Mode 1 and 0 (PF1MD1, PF1MD0)

Bits 1 and 0—PF0 Mode 1 and 0 (PF0MD1, PF0MD0)

These bits select the pin functions and perform input pull-up MOS control.

Bit (2n + 1) Bit 2n

PFnMD1	PFnMD0	Pin Function	
0	0	Other function (see table 18.1)	(Initial value) $\overline{(\text{ASEMD0} = 0)}$
0	1	Reserved	
1	0	Port input (Pull-up MOS: on)	(Initial value) $\overline{(\text{ASEMD0} = 1)}$
1	1	Port input (Pull-up MOS: off)	

(n = 4 to 7)

Bit (2n + 1) Bit 2n

PFnMD1	PFnMD0	Pin Function	
0	0	Other function (see table 18.1)	
0	1	Reserved	
1	0	Port input (Pull-up MOS: on)	(Initial value)
1	1	Port input (Pull-up MOS: off)	

(n = 0 to 3)

18.3.7 Port G Control Register (PGCR)

Bit:	15	14	13	12	11	10	9	8	7	6	5	4	3	2	1	0
	PG7 MD1	PG7 MD0	PG6 MD1	PG6 MD0	PG5 MD1	PG5 MD0	PG4 MD1	PG4 MD0	PG3 MD1	PG3 MD0	PG2 MD1	PG2 MD0	PG1 MD1	PG1 MD0	PG0 MD1	PG0 MD0
Initial value:	1	0	1	0	1/0	0	1	0	1/0	0	1/0	0	1/0	0	1/0	0
R/W:	R/W	R/W	R/W	R/W	R/W	R/W	R/W	R/W	R/W	R/W	R/W	R/W	R/W	R/W	R/W	R/W

The port G control register (PGCR) is a 16-bit readable/writable register that selects the pin functions. PGCR is initialized to H'AAAA ($\overline{ASEMD0} = 1$) or H'A200 ($\overline{ASEMD0} = 0$) by a power-on reset, but is not initialized by a manual reset, in standby mode, or in sleep mode.

Bits 15 and 14—PG7 Mode 1 and 0 (PG7MD1, PG7MD0)

Bits 13 and 12—PG6 Mode 1 and 0 (PG6MD1, PG6MD0)

Bits 11 and 10—PG5 Mode 1 and 0 (PG5MD1, PG5MD0)

Bits 9 and 8—PG4 Mode 1 and 0 (PG4MD1, PG4MD0)

Bits 7 and 6—PG3 Mode 1 and 0 (PG3MD1, PG3MD0)

Bits 5 and 4—PG2 Mode 1 and 0 (PG2MD1, PG2MD0)

Bits 3 and 2—PG1 Mode 1 and 0 (PG1MD1, PG1MD0)

Bits 1 and 0—PG0 Mode 1 and 0 (PG0MD1, PG0MD0)

These bits select the pin functions and perform input pull-up MOS control.

Bit (2n + 1)	Bit 2n	Pin Function
0	0	Other function (n = 1–3, 5) (see table 18.1) (Initial value) $\overline{\text{ASEMD0}} = 0$
0	1	Reserved
1	0	Port input (Pull-up MOS: on) (Initial value) $\overline{\text{ASEMD0}} = 1$
1	1	Port input (Pull-up MOS: off)

(n = 1 to 3, 5)

Bit (2n + 1)	Bit 2n	Pin Function
0	0	Other function (n = 4, 6, 7) (see table 18.1)
0	1	Reserved
1	0	Port input (Pull-up MOS: on) (Initial value)*
1	1	Port input (Pull-up MOS: off)

(n = 4, 6, 7)

Note: * When n = 6, $\overline{\text{ASEMD0}}/\text{PTG6}$ functions as $\overline{\text{ASEMD0}}$ input while the reset signal is asserted, and as PTG6 input immediately after the reset signal is negated.

Bit 3	Bit 0	Pin Function
0	0	Other function (see table 18.1) (Initial value) $\overline{\text{ASEMD0}} = 0$
0	1	Reserved
1	0	Port input (Pull-up MOS: on) (Initial value) $\overline{\text{ASEMD0}} = 1$
1	1	Port input (Pull-up MOS: off)

Note: * Controlled by PG1MD1 (bit 3), not PG0MD1 (bit 1).

18.3.8 Port H Control Register (PHCR)

Bit:	15	14	13	12	11	10	9	8	7	6	5	4	3	2	1	0
	PH7 MD1	PH7 MD0	PH6 MD1	PH6 MD0	PH5 MD1	PH5 MD0	PH4 MD1	PH4 MD0	PH3 MD1	PH3 MD0	PH2 MD1	PH2 MD0	PH1 MD1	PH1 MD0	PH0 MD1	PH0 MD0
Initial value:	1	0	1/0	0	1	0	1	0	1	0	1	0	1	0	1	0
R/W:	R/W	R/W	R/W	R/W	R/W	R/W	R/W	R/W	R/W	R/W	R/W	R/W	R/W	R/W	R/W	R/W

The port H control register (PHCR) is a 16-bit readable/writable register that selects the pin functions. PHCR is initialized to H'AAAA ($\overline{\text{ASEMD0}} = 1$) or H'8AAA ($\overline{\text{ASEMD0}} = 0$) by a power-on reset, but is not initialized by a manual reset, in standby mode, or in sleep mode.

Bits 15 and 14—PH7 Mode 1, 0 (PH7MD1, PH7MD0): These bits select the pin functions and perform input pull-up MOS control.

Bit 15	Bit 14	Pin Function
PH7MD1	PH7MD0	
0	0	Other function (see table 18.1)
0	1	Port output
1	0	Port input (Pull-up MOS: on) (Initial value)
1	1	Port input (Pull-up MOS: off)

Bits 13 and 12—PH6 Mode 1 and 0 (PH6MD1, PH6MD0)

Bits 11 and 10—PH5 Mode 1 and 0 (PH5MD1, PH5MD0)

Bits 9 and 8—PH4 Mode 1 and 0 (PH4MD1, PH4MD0)

Bits 7 and 6—PH3 Mode 1 and 0 (PH3MD1, PH3MD0)

Bits 5 and 4—PH2 Mode 1 and 0 (PH2MD1, PH2MD0)

Bits 3 and 2—PH1 Mode 1 and 0 (PH1MD1, PH1MD0)

Bits 1 and 0—PH0 Mode 1 and 0 (PH0MD1, PH0MD0)

These bits select the pin functions and perform input pull-up MOS control.

Bit 13	Bit 12	Pin Function
PH6MD1	PH6MD0	
0	0	Other function (see table 18.1) (Initial value) ($\overline{\text{ASEMD0}} = 0$)
0	1	Reserved
1	0	Port input (Pull-up MOS: on) (Initial value) ($\overline{\text{ASEMD0}} = 1$)
1	1	Port input (Pull-up MOS: off)

Bit (2n + 1)	Bit 2n	Pin Function
PHnMD1	PHnMD0	
0	0	Other function (see table 18.1)
0	1	Reserved
1	0	Port input (Pull-up MOS: on) (Initial value)
1	1	Port input (Pull-up MOS: off)

(n = 0 to 5)

18.3.9 Port J Control Register (PJCR)

Bit: 15 14 13 12 11 10 9 8 7 6 5 4 3 2 1 0

PJ7 MD1	PJ7 MD0	PJ6 MD1	PJ6 MD0	PJ5 MD1	PJ5 MD0	PJ4 MD1	PJ4 MD0	PJ3 MD1	PJ3 MD0	PJ2 MD1	PJ2 MD0	PJ1 MD1	PJ1 MD0	PJ0 MD1	PJ0 MD0
------------	------------	------------	------------	------------	------------	------------	------------	------------	------------	------------	------------	------------	------------	------------	------------

Initial value: 0 0 0 0 0 0 0 0 0 0 0 0 0 0 0 0

R/W: R/W R/W R/W R/W R/W R/W R/W R/W R/W R/W R/W R/W R/W R/W R/W R/W

The port J control register (PJCR) is a 16-bit readable/writable register that selects the pin functions. PJCR is initialized to H'0000 by a power-on reset, but is not initialized by a manual reset, in standby mode, or in sleep mode.

Bits 15 and 14—PJ7 Mode 1 and 0 (PJ7MD1, PJ7MD0)

Bits 13 and 12—PJ6 Mode 1 and 0 (PJ6MD1, PJ6MD0)

Bits 11 and 10—PJ5 Mode 1 and 0 (PJ5MD1, PJ5MD0)

Bits 9 and 8—PJ4 Mode 1 and 0 (PJ4MD1, PJ4MD0)

Bits 7 and 6—PJ3 Mode 1 and 0 (PJ3MD1, PJ3MD0)

Bits 5 and 4—PJ2 Mode 1 and 0 (PJ2MD1, PJ2MD0)

Bits 3 and 2—PJ1 Mode 1 and 0 (PJ1MD1, PJ1MD0)

Bits 1 and 0—PJ0 Mode 1 and 0 (PJ0MD1, PJ0MD0)

These bits select the pin functions and perform input pull-up MOS control.

Bit (2n + 1) Bit 2n

PJnMD1	PJnMD0	Pin Function
0	0	Other function (n = 0, 2, 3, 6, 7) (see table 18.1), Reserved (n = 1, 4, 5) (Initial value)
0	1	Port output
1	0	Port input (Pull-up MOS: on)
1	1	Port input (Pull-up MOS: off)

(n = 0 to 7)

18.3.10 Port K Control Register (PKCR)

Bit:	15	14	13	12	11	10	9	8	7	6	5	4	3	2	1	0
	PK7 MD1	PK7 MD0	PK6 MD1	PK6 MD0	PK5 MD1	PK5 MD0	PK4 MD1	PK4 MD0	PK3 MD1	PK3 MD0	PK2 MD1	PK2 MD0	PK1 MD1	PK1 MD0	PK0 MD1	PK0 MD0
Initial value:	0	0	0	0	0	0	0	0	0	0	0	0	0	0	0	0
R/W:	R/W	R/W	R/W	R/W	R/W	R/W	R/W	R/W	R/W	R/W	R/W	R/W	R/W	R/W	R/W	R/W

The port K control register (PKCR) is a 16-bit readable/writable register that selects the pin functions. PKCR is initialized to H'0000 by a power-on reset, but is not initialized by a manual reset, in standby mode, or in sleep mode.

Bits 15 and 14—PK7 Mode 1 and 0 (PK7MD1, PK7MD0)

Bits 13 and 12—PK6 Mode 1 and 0 (PK6MD1, PK6MD0)

Bits 11 and 10—PK5 Mode 1 and 0 (PK5MD1, PK5MD0)

Bits 9 and 8—PK4 Mode 1 and 0 (PK4MD1, PK4MD0)

Bits 7 and 6—PK3 Mode 1 and 0 (PK3MD1, PK3MD0)

Bits 5 and 4—PK2 Mode 1 and 0 (PK2MD1, PK2MD0)

Bits 3 and 2—PK1 Mode 1 and 0 (PK1MD1, PK1MD0)

Bits 1 and 0—PK0 Mode 1 and 0 (PK0MD1, PK0MD0)

These bits select the pin functions and perform input pull-up MOS control.

Bit (2n + 1) Bit 2n

PKnMD1	PKnMD0	Pin Function
0	0	Other function (see table 18.1) (Initial value)
0	1	Port output
1	0	Port input (Pull-up MOS: on)
1	1	Port input (Pull-up MOS: off)

(n = 0 to 7)

18.3.11 Port L Control Register (PLCR)

Bit:	15	14	13	12	11	10	9	8	7	6	5	4	3	2	1	0
	PL7 MD1	PL7 MD0	PL6 MD1	PL6 MD0	PL5 MD1	PL5 MD0	PL4 MD1	PL4 MD0	PL3 MD1	PL3 MD0	PL2 MD1	PL2 MD0	PL1 MD1	PL1 MD0	PL0 MD1	PL0 MD0
Initial value:	0	0	0	0	0	0	0	0	0	0	0	0	0	0	0	0
R/W:	R/W	R/W	R/W	R/W	R/W	R/W	R/W	R/W	R/W	R/W	R/W	R/W	R/W	R/W	R/W	R/W

The port L control register (PLCR) is a 16-bit readable/writable register that selects the pin functions. PLCR is initialized to H'0000 by a power-on reset, but is not initialized by a manual reset, in standby mode, or in sleep mode.

Bits 15 and 14—PL7 Mode 1 and 0 (PL7MD1, PL7MD0)

Bits 13 and 12—PL6 Mode 1 and 0 (PL6MD1, PL6MD0)

Bits 11 and 10—PL5 Mode 1 and 0 (PL5MD1, PL5MD0)

Bits 9 and 8—PL4 Mode 1 and 0 (PL4MD1, PL4MD0)

Bits 7 and 6—PL3 Mode 1 and 0 (PL3MD1, PL3MD0)

Bits 5 and 4—PL2 Mode 1 and 0 (PL2MD1, PL2MD0)

Bits 3 and 2—PL1 Mode 1 and 0 (PL1MD1, PL1MD0)

Bits 1 and 0—PL0 Mode 1 and 0 (PL0MD1, PL0MD0)

These bits select the pin functions and perform input pull-up MOS control.

Bit (2n + 1)	Bit 2n	Pin Function	
PLnMD1	PLnMD0		
0	0	Other function (see table 18.1)	(Initial value)
0	1	Reserved	
1	0	Port input (Pull-up MOS: on)	
1	1	Port input (Pull-up MOS: off)	

(n = 0 to 7)

When the DA0 and DA1 pins are used as the D/A converter outputs or when PTL7 and PTL6 are used in the “other function” state, PLCR should be kept at its initial value.

18.3.12 SC Port Control Register (SCPCR)

Bit: 15 14 13 12 11 10 9 8 7 6 5 4 3 2 1 0

SCP7 MD1	SCP7 MD0	SCP6 MD1	SCP6 MD0	SCP5 MD1	SCP5 MD0	SCP4 MD1	SCP4 MD0	SCP3 MD1	SCP3 MD0	SCP2 MD1	SCP2 MD0	SCP1 MD1	SCP1 MD0	SCP0 MD1	SCP0 MD0
-------------	-------------	-------------	-------------	-------------	-------------	-------------	-------------	-------------	-------------	-------------	-------------	-------------	-------------	-------------	-------------

Initial value: 1 0 1 0 1 0 0 0 1 0 0 0 1 0 0 0

R/W: R/W R/W R/W R/W R/W R/W R/W R/W R/W R/W R/W R/W R/W R/W R/W R/W

The SC port control register (SCPCR) is a 16-bit readable/writable register that selects the pin functions. The setting of SCPCR is valid only when transmit/receive operations are disabled in the SCSCR register. SCPCR is initialized to H'A888 by a power-on reset, but is not initialized by a manual reset, in standby mode, or in sleep mode. When the TE bit in SCSCR is set to 1, the “other function” output state has a higher priority than the SCPCR setting for the TxD[2:0] pins. When the RE bit in SCSCR is set to 1, the input state has a higher priority than the SCPCR setting for the RxD[2:0] pins.

Bits 15 and 14—SCP7 Mode 1 and 0 (SCP7MD1, SCP7MD0): These bits select the pin function and perform input pull-up MOS control.

Bit 15	Bit 14	Pin Function
SCP7MD1	SCP7MD0	
0	0	Other function (see table 18.1)
0	1	Reserved
1	0	Port input (Pull-up MOS: on) (Initial value)
1	1	Port input (Pull-up MOS: off)

Bits 13, 12—SCP6 Mode 1, 0 (SCP6MD1, SCP6MD0): These bits select the pin function and perform input pull-up MOS control.

Bit 13	Bit 12	Pin Function
SCP6MD1	SCP6MD0	
0	0	Other function (see table 18.1)
0	1	Port output
1	0	Port input (Pull-up MOS: on) (Initial value)
1	1	Port input (Pull-up MOS: off)

Bits 11 and 10—SCP5 Mode 1 and 0 (SCP5MD1, SCP5MD0): These bits select the pin functions and perform input pull-up MOS control.

Bit 11	Bit 10	Pin Function
SCP5MD1	SCP5MD0	
0	0	Other function (see table 18.1)
0	1	Port output
1	0	Port input (Pull-up MOS: on) (Initial value)
1	1	Port input (Pull-up MOS: off)

Bits 9 and 8—SCP4 Mode 1 and 0 (SCP4MD1, SCP4MD0): These bits select the pin function and perform input pull-up MOS control.

Bit 9	Bit 8	Pin Function
SCP4MD1	SCP4MD0	
0	0	Transmit data output 2 (TxD2) Receive data input 2 (RxD2) (Initial value)
0	1	General output (SCPT[4] output pin) Receive data input 2 (RxD2)
1	0	SCPT[4] input pin pull-up (input pin) Transmit data output 2 (TxD2)
1	1	General input (SCPT[4] input pin) Transmit data output 2 (TxD2)

Note: There is no SCPT[4] simultaneous I/O combination because one bit (SCP4DT) is accessed using two pins, TxD2 and RxD2.

When port input is set (bit SCPnMD1 is set to 1) and when the TE bit in SCSCR is set to 1, the TxD2 pin is in the output state. When the TE bit is cleared to 0, the TxD2 pin goes to the high-impedance state.

Bits 7 and 6—SCP3 Mode 1 and 0 (SCP3MD1, SCP3MD0): These bits select the pin function and perform input pull-up MOS control.

Bit 7	Bit 6	Pin Function
SCP3MD1	SCP3MD0	
0	0	Other function (see table 18.1)
0	1	Port output
1	0	Port input (Pull-up MOS: on) (Initial value)
1	1	Port input (Pull-up MOS: off)

Bits 5 and 4—SCP2 Mode 1 and 0 (SCP2MD1, SCP2MD0): These bits select the pin function and perform input pull-up MOS control.

Bit 5	Bit 4	Pin Function
SCP2MD1	SCP2MD0	
0	0	Transmit data output 1 (TxD1) Receive data input 1 (RxD1) (Initial value)
0	1	General output (SCPT[2] output pin) Receive data input 1 (RxD1)
1	0	SCPT[2] input pin pull-up (input pin) Transmit data output 1 (TxD1)
1	1	General input (SCPT[2] input pin) Transmit data output 1 (TxD1)

Note: There is no SCPT[2] simultaneous I/O combination because one bit (SCP2DT) is accessed using two pins, TxD1 and RxD1.

When port input is set (bit SCPnMD1 is set to 1) and when the TE bit in SCSCR is set to 1, the TxD1 pin is in the output state. When the TE bit is cleared to 0, the TxD1 pin goes to the high-impedance state.

Bits 3 and 2—SCP1 Mode 1 and 0 (SCP1MD1, SCP1MD0): These bits select the pin function and perform input pull-up MOS control.

Bit 3	Bit 2	Pin Function
SCP1MD1	SCP1MD0	
0	0	Other function (see table 18.1)
0	1	Port output
1	0	Port input (Pull-up MOS: on) (Initial value)
1	1	Port input (Pull-up MOS: off)

Bits 1 and 0—SCP0 Mode 1 and 0 (SCP0MD1, SCP0MD0): These bits select the pin function and perform input pull-up MOS control.

Bit 1	Bit 0	Pin Function
SCP0MD1	SCP0MD0	
0	0	Transmit data output 0 (TxD0) Receive data input 0 (RxD0) (Initial value)
0	1	General output (SCPT[0] output pin) Receive data input 0 (RxD0)
1	0	SCPT[0] input pin pull-up (input pin) Transmit data output 0 (TxD0)
1	1	General input (SCPT[0] input pin) Transmit data output 0 (TxD0)

Note: There is no SCPT[0] simultaneous I/O combination because one bit (SCP0DT) is accessed using two pins, TxD0 and RxD0.

When port input is set (bit SCPnMD1 is set to 1) and when the TE bit in SCSCR is set to 1, the TxD0 pin is in the output state. When the TE bit is cleared to 0, the TxD0 pin goes to the high-impedance state.

Section 19 I/O Ports

19.1 Overview

The SH7709S has twelve 8-bit ports (ports A to L and SC). All port pins are multiplexed with other pin functions (the pin function controller (PFC) handles the selection of pin functions and pull-up MOS control). Each port has a data register which stores data for the pins.

19.2 Port A

Port A is an 8-bit input/output port with the pin configuration shown in figure 19.1. Each pin has an input pull-up MOS, which is controlled by the port A control register (PACR) in the PFC.

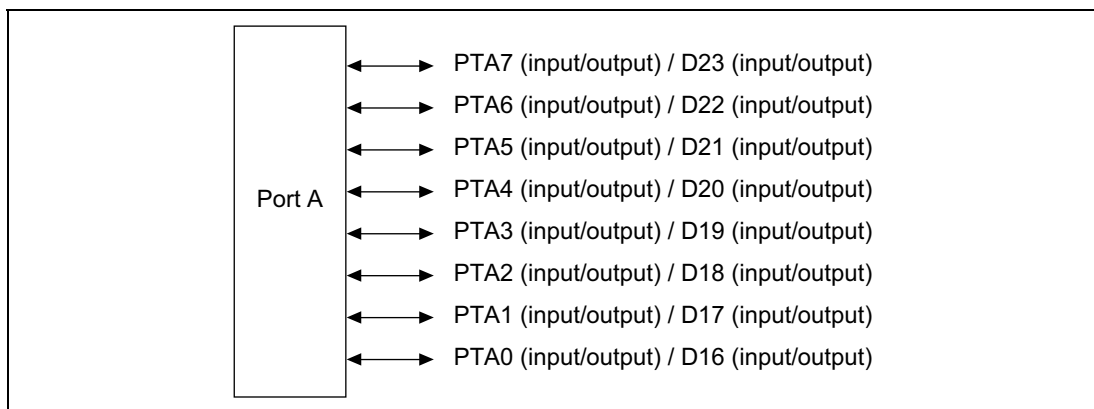

Figure 19.1 Port A

19.2.1 Register Description

Table 19.1 summarizes the port A register.

Table 19.1 Port A Register

Name	Abbreviation	R/W	Initial Value	Address	Access Size
Port A data register	PADR	R/W	H'00	H'04000120 (H'A4000120)*	8

Notes: This register is located in area 1 of physical space. Therefore, when the cache is on, either access this register from the P2 area of logical space or else make an appropriate setting using the MMU so that this register is not cached.

* When address translation by the MMU does not apply, the address in parentheses should be used.

19.2.2 Port A Data Register (PADR)

Bit:	7	6	5	4	3	2	1	0
	PA7DT	PA6DT	PA5DT	PA4DT	PA3DT	PA2DT	PA1DT	PA0DT
Initial value:	0	0	0	0	0	0	0	0
R/W:	R/W	R/W	R/W	R/W	R/W	R/W	R/W	R/W

The port A data register (PADR) is an 8-bit readable/writable register that stores data for pins PTA7 to PTA0. Bits PA7DT to PA0DT correspond to pins PTA7 to PTA0. When the pin function is general output port, if the port is read the value of the corresponding PADR bit is returned directly. When the function is general input port, if the port is read the corresponding pin level is read. Table 19.2 shows the function of PADR.

PADR is initialized to H'00 by a power-on reset. It retains its previous value in standby mode and sleep mode, and in a manual reset.

Table 19.2 Port A Data Register (PADR) Read/Write Operations

PAnMD1	PAnMD0	Pin State	Read	Write
0	0	Other function (See table 18.1)	PADR value	Value is written to PADR, but does not affect pin state
	1	Output	PADR value	Write value is output from pin
1	0	Input (Pull-up MOS on)	Pin state	Value is written to PADR, but does not affect pin state
	1	Input (Pull-up MOS off)	Pin state	Value is written to PADR, but does not affect pin state

(n = 7 to 0)

19.3 Port B

Port B is an 8-bit input/output port with the pin configuration shown in figure 19.2. Each pin has an input pull-up MOS, which is controlled by the port B control register (PBCR) in the PFC.

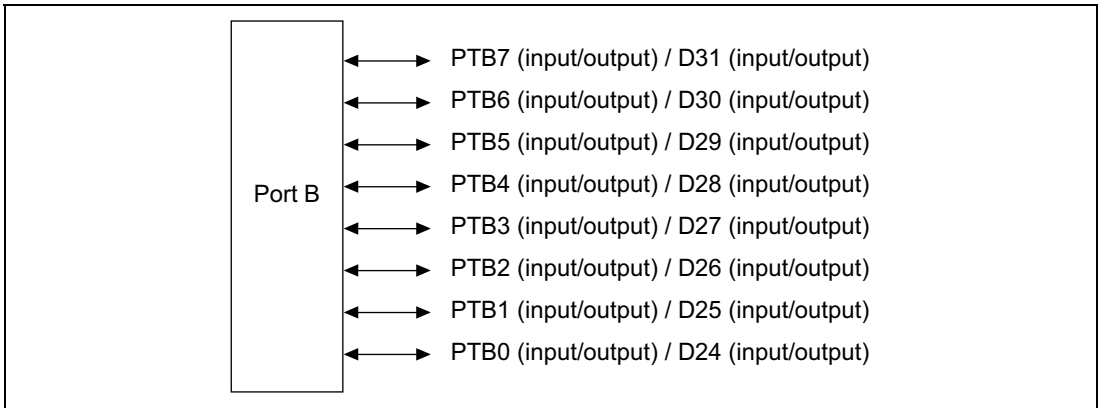

Figure 19.2 Port B

19.3.1 Register Description

Table 19.3 summarizes the port B register.

Table 19.3 Port B Register

Name	Abbreviation	R/W	Initial Value	Address	Access Size
Port B data register	PBDR	R/W	H'00	H'04000122 (H'A4000122)*	8

Notes: This register is located in area 1 of physical space. Therefore, when the cache is on, either access this register from the P2 area of logical space or else make an appropriate setting using the MMU so that this register is not cached.

* When address translation by the MMU does not apply, the address in parentheses should be used.

19.3.2 Port B Data Register (PBDR)

Bit:	7	6	5	4	3	2	1	0
	PB7DT	PB6DT	PB5DT	PB4DT	PB3DT	PB2DT	PB1DT	PB0DT
Initial value:	0	0	0	0	0	0	0	0
R/W:	R/W	R/W	R/W	R/W	R/W	R/W	R/W	R/W

The port B data register (PBDR) is an 8-bit readable/writable register that stores data for pins PTB7 to PTB0. Bits PB7DT to PB0DT correspond to pins PTB7 to PTB0. When the pin function is general output port, if the port is read the value of the corresponding PBDR bit is returned directly. When the function is general input port, if the port is read the corresponding pin level is read. Table 19.4 shows the function of PBDR.

PBDR is initialized to H'00 by a power-on reset. It retains its previous value in standby mode and sleep mode, and in a manual reset.

Table 19.4 Port B Data Register (PBDR) Read/Write Operations

PBnMD1	PBnMD0	Pin State	Read	Write
0	0	Other function (See table 18.1)	PBDR value	Value is written to PBDR, but does not affect pin state
	1	Output	PBDR value	Write value is output from pin
1	0	Input (Pull-up MOS on)	Pin state	Value is written to PBDR, but does not affect pin state
	1	Input (Pull-up MOS off)	Pin state	Value is written to PBDR, but does not affect pin state

(n = 7 to 0)

19.4 Port C

Port C is an 8-bit input/output port with the pin configuration shown in figure 19.3. Each pin has an input pull-up MOS, which is controlled by the port C control register (PCCR) in the PFC.

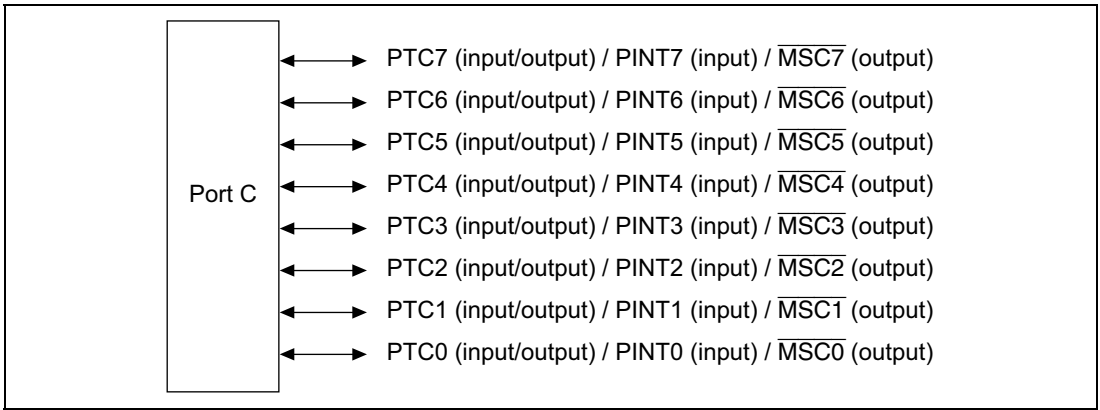

Figure 19.3 Port C

19.4.1 Register Description

Table 19.5 summarizes the port C register.

Table 19.5 Port C Register

Name	Abbreviation	R/W	Initial Value	Address	Access Size
Port C data register	PCDR	R/W	H'00	H'04000124 (H'A4000124)*	8

Notes: This register is located in area 1 of physical space. Therefore, when the cache is on, either access this register from the P2 area of logical space or else make an appropriate setting using the MMU so that this register is not cached.

* When address translation by the MMU does not apply, the address in parentheses should be used.

19.4.2 Port C Data Register (PCDR)

Bit:	7	6	5	4	3	2	1	0
	PC7DT	PC6DT	PC5DT	PC4DT	PC3DT	PC2DT	PC1DT	PC0DT
Initial value:	0	0	0	0	0	0	0	0
R/W:	R/W	R/W	R/W	R/W	R/W	R/W	R/W	R/W

The port C data register (PCDR) is an 8-bit readable/writable register that stores data for pins PTC7 to PTC0. Bits PC7DT to PC0DT correspond to pins PTC7 to PTC0. When the pin function is general output port, if the port is read, the value of the corresponding PCDR bit is returned directly. When the function is general input port, if the port is read, the corresponding pin level is read. Table 19.6 shows the function of PCDR.

PCDR is initialized to H'00 by a power-on reset, after which the general input port function (pull-up MOS on) is set as the initial pin function, and the corresponding pin levels are read.

PCDR retains its previous value in standby mode and sleep mode, and in a manual reset.

Table 19.6 Port C Data Register (PCDR) Read/Write Operations

PCnMD1	PCnMD0	Pin State	Read	Write
0	0	Other function (see table 18.1)	PCDR value	Value is written to PCDR, but does not affect pin state
	1	Output	PCDR value	Write value is output from pin
1	0	Input (Pull-up MOS on)	Pin state	Value is written to PCDR, but does not affect pin state
	1	Input (Pull-up MOS off)	Pin state	Value is written to PCDR, but does not affect pin state

(n = 7 to 0)

19.5 Port D

Port D comprises a 6-bit input/output port and 2-bit input port with the pin configuration shown in figure 19.4. Each pin has an input pull-up MOS, which is controlled by the port D control register (PDCR) in the PFC.

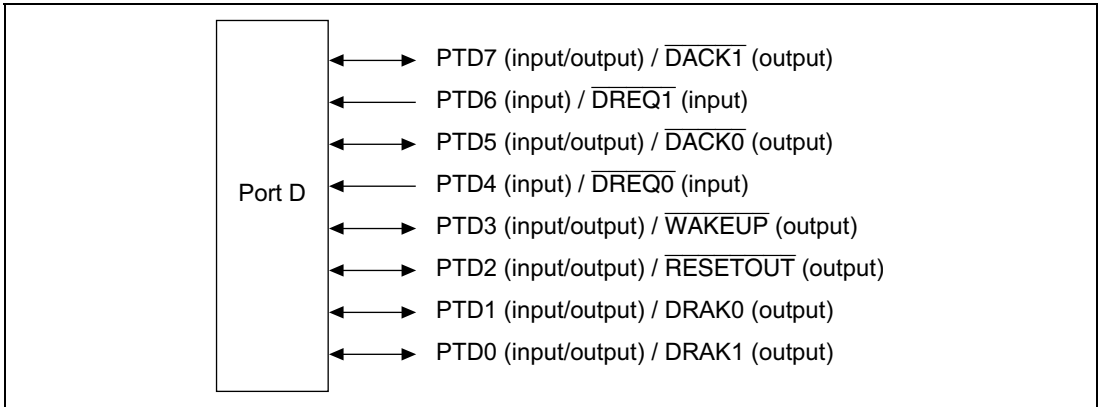

Figure 19.4 Port D

19.5.1 Register Description

Table 19.7 summarizes the port D register.

Table 19.7 Port D Register

Name	Abbreviation	R/W	Initial Value	Address	Access Size
Port D data register	PDDR	R/W or R	B'0*0*0000	H'04000126 (H'A4000126)*1	8

Notes: This register is located in area 1 of physical space. Therefore, when the cache is on, either access this register from the P2 area of logical space or else make an appropriate setting using the MMU so that this register is not cached.

* Means no value.

*1 When address translation by the MMU does not apply, the address in parentheses should be used.

19.5.2 Port D Data Register (PDDR)

Bit:	7	6	5	4	3	2	1	0
	PD7DT	PD6DT	PD5DT	PD4DT	PD3DT	PD2DT	PD1DT	PD0DT
Initial value:	0	*	0	*	0	0	0	0
R/W:	R/W	R	R/W	R	R/W	R/W	R/W	R/W

Note: * Undefined

The port D data register (PDDR) is a 6-bit readable/writable and 2-bit read-only register that stores data for pins PTD7 to PTD0. Bits PD7DT to PD0DT correspond to pins PTD7 to PTD0. When the pin function is general output port, if the port is read, the value of the corresponding PDDR bit is returned directly. When the function is general input port, if the port is read, the corresponding pin level is read. Table 19.8 shows the function of PDDR.

PDDR is initialized to B'0*0*0000 by a power-on reset. After initialization, the general input port function (pull-up MOS on) is set as the initial pin function, and the corresponding pin levels are read from bits PD7DT—PD3DT, PD1DT, and PD0DT. PDDR retains its previous value in standby mode and sleep mode, and in a manual reset.

Note that the low level is read if bits 6 and 4 are read except in general-purpose input.

Table 19.8 Port D Data Register (PDDR) Read/Write Operations

PDnMD1	PDnMD0	Pin State	Read	Write
0	0	Other function (see table 18.1)	PDDR value	Value is written to PDDR, but does not affect pin state
	1	Output	PDDR value	Write value is output from pin
1	0	Input (Pull-up MOS on)	Pin state	Value is written to PDDR, but does not affect pin state
	1	Input (Pull-up MOS off)	Pin state	Value is written to PDDR, but does not affect pin state

(n = 0, 1, 2, 3, 5, 7)

PDnMD1	PDnMD0	Pin State	Read	Write
0	0	Other function (see table 18.1)	Low level	Ignored (no effect on pin state)
	1	Reserved	Low level	Ignored (no effect on pin state)
1	0	Input (Pull-up MOS on)	Pin state	Ignored (no effect on pin state)
	1	Input (Pull-up MOS off)	Pin state	Ignored (no effect on pin state)

(n = 4, 6)

19.6 Port E

Port E is an 8-bit input/output port with the pin configuration shown in figure 19.5. Each pin has an input pull-up MOS, which is controlled by the port E control register (PECR) in the PFC.

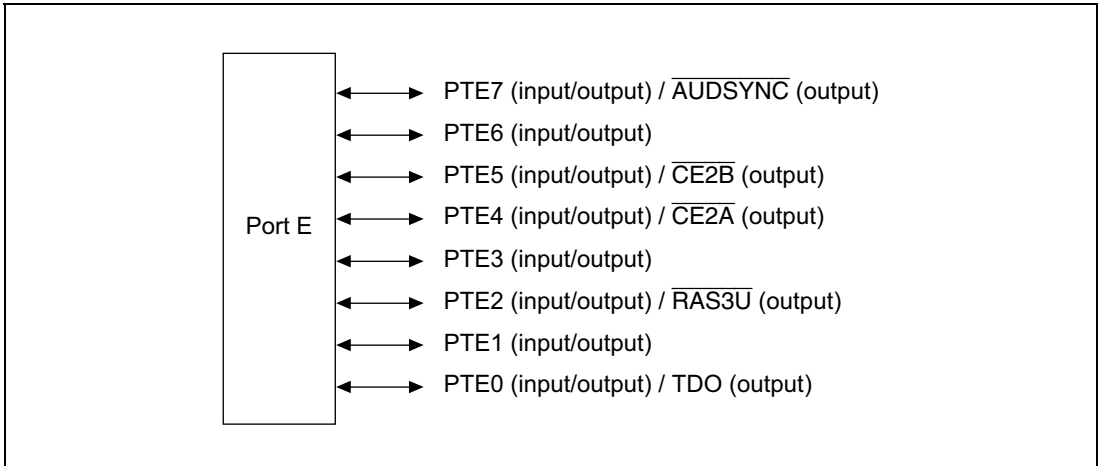

Figure 19.5 Port E

19.6.1 Register Description

Table 19.9 summarizes the port E register.

Table 19.9 Port E Register

Name	Abbreviation	R/W	Initial Value	Address	Access Size
Port E data register	PEDR	R/W	H'00	H'04000128 (H'A4000128)*	8

Notes: This register is located in area 1 of physical space. Therefore, when the cache is on, either access this register from the P2 area of logical space or else make an appropriate setting using the MMU so that this register is not cached.

* When address translation by the MMU does not apply, the address in parentheses should be used.

19.6.2 Port E Data Register (PEDR)

Bit:	7	6	5	4	3	2	1	0
	PE7DT	PE6DT	PE5DT	PE4DT	PE3DT	PE2DT	PE1DT	PE0DT
Initial value:	0	0	0	0	0	0	0	0
R/W:	R/W	R/W	R/W	R/W	R/W	R/W	R/W	R/W

The port E data register (PEDR) is an 8-bit readable/writable register that stores data for pins PTE7 to PTE0. Bits PE7DT to PE0DT correspond to pins PTE7 to PTE0. When the pin function is general output port, if the port is read the value of the corresponding PEDR bit is returned directly. When the function is general input port, if the port is read the corresponding pin level is read. Table 19.10 shows the function of PEDR.

PEDR is initialized to H'00 by a power-on reset, after which the general input port function (pull-up MOS on) is set as the initial pin function, and the corresponding pin levels are read. It retains its previous value in standby mode and sleep mode, and in a manual reset.

Table 19.10 Port E Data Register (PEDR) Read/Write Operations

PE _n MD1	PE _n MD0	Pin State	Read	Write
0	0	Other function (see table 18.1)	PEDR value	Value is written to PEDR, but does not affect pin state
	1	Output	PEDR value	Write value is output from pin
1	0	Input (Pull-up MOS on)	Pin state	Value is written to PEDR, but does not affect pin state
	1	Input (Pull-up MOS off)	Pin state	Value is written to PEDR, but does not affect pin state

(n = 0 to 7)

19.7 Port F

Port F is an 8-bit input port with the pin configuration shown in figure 19.6. Each pin has an input pull-up MOS, which is controlled by the port F control register (PFCR) in the PFC.

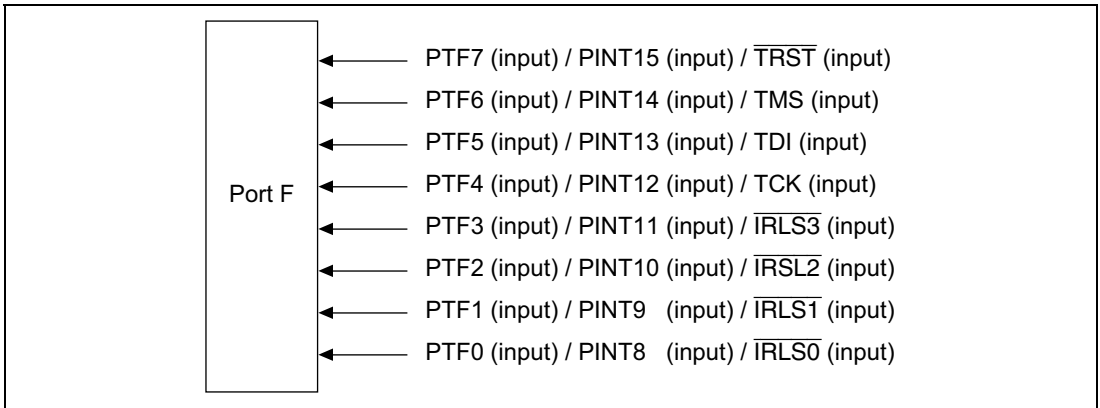

Figure 19.6 Port F

19.7.1 Register Description

Table 19.11 summarizes the port F register.

Table 19.11 Port F Register

Name	Abbreviation	R/W	Initial Value	Address	Access Size
Port F data register	PFDR	R	H'**	H'0400012A (H'A400012A)*1	8

Notes: This register is located in area 1 of physical space. Therefore, when the cache is on, either access this register from the P2 area of logical space or else make an appropriate setting using the MMU so that this register is not cached.

* Means no value.

*1 When address translation by the MMU does not apply, the address in parentheses should be used.

19.7.2 Port F Data Register (PFDR)

Bit:	7	6	5	4	3	2	1	0
	PF7DT	PF6DT	PF5DT	PF4DT	PF3DT	PF2DT	PF1DT	PF0DT
Initial value:	*	*	*	*	*	*	*	*
R/W:	R	R	R	R	R	R	R	R

Note: * Undefined

The port F data register (PFDR) is an 8-bit read-only register that stores data for pins PTF7 to PTF0. Bits PF7DT to PF0DT correspond to pins PTF7 to PTF0. When the function is general input port, if the port is read the corresponding pin level is read. Table 19.12 shows the function of PFDR.

PFDR is initialized by a power-on reset, after which the general input port function (pull-up MOS on) is set as the initial pin function, and the corresponding pin levels are read.

Table 19.12 Port F Data Register (PFDR) Read/Write Operations

PFnMD1	PFnMD0	Pin State	Read	Write
0	0	Other function (see table 18.1)	H'00	Ignored (no effect on pin state)
	1	Reserved	H'00	Ignored (no effect on pin state)
1	0	Input (Pull-up MOS on)	Pin state	Ignored (no effect on pin state)
	1	Input (Pull-up MOS off)	Pin state	Ignored (no effect on pin state)

(n = 0 to 7)

19.8 Port G

Port G comprises a 5-bit input/output port and 3-bit input port with the pin configuration shown in figure 19.7. Each pin has an input pull-up MOS, which is controlled by the port G control register (PGCR) in the PFC.

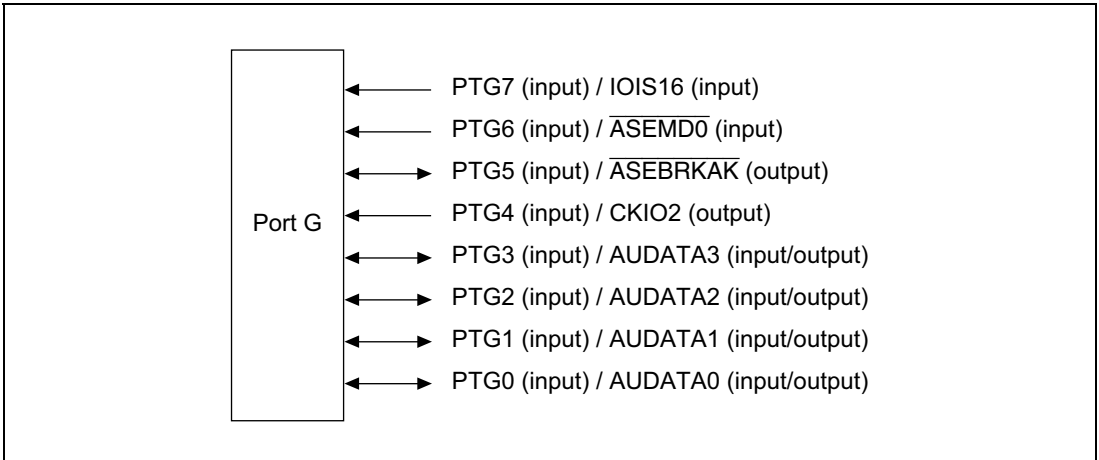

Figure 19.7 Port G

19.8.1 Register Description

Table 19.13 summarizes the port G register.

Table 19.13 Port G Register

Name	Abbreviation	R/W	Initial Value	Address	Access Size
Port G data register	PGDR	R/W	H'***	H'0400012C (H'A400012C)*1	8

Notes: This register is located in area 1 of physical space. Therefore, when the cache is on, either access this register from the P2 area of logical space or else make an appropriate setting using the MMU so that this register is not cached.

* Means no value.

*1 When address translation by the MMU does not apply, the address in parentheses should be used.

19.8.2 Port G Data Register (PGDR)

Bit:	7	6	5	4	3	2	1	0
	PG7DT	PG6DT	PG5DT	PG4DT	PG3DT	PG2DT	PG1DT	PG0DT
Initial value:	*	*	*	*	*	*	*	*
R/W:	R	R	R	R	R	R	R	R

Note: * Undefined

The port G data register (PGDR) is an 8-bit read-only register that stores data for pins PTG7 to PTG0. Bits PG7DT to PG0DT correspond to pins PTG7 to PTG0. When the function is general input port, if the port is read the corresponding pin level is read. Table 19.14 shows the function of PGDR.

PGDR is initialized by a power-on reset, after which the general input port function (pull-up MOS on) is set as the initial pin function, and the corresponding pin levels are read.

Table 19.14 Port G Data Register (PGDR) Read/Write Operations

PGnMD1	PGnMD0	Pin State	Read	Write
0	0	Other function (see table 18.1)	H'00	Ignored (no effect on pin state)
	1	Reserved	H'00	Ignored (no effect on pin state)
1	0	Input (Pull-up MOS on)	Pin state	Ignored (no effect on pin state)
	1	Input (Pull-up MOS off)	Pin state	Ignored (no effect on pin state)

(n = 0 to 7)

19.9 Port H

Port H comprises a 1-bit input/output port and 7-bit input port with the pin configuration shown in figure 19.8. Each pin has an input pull-up MOS, which is controlled by the port H control register (PHCR) in the PFC.

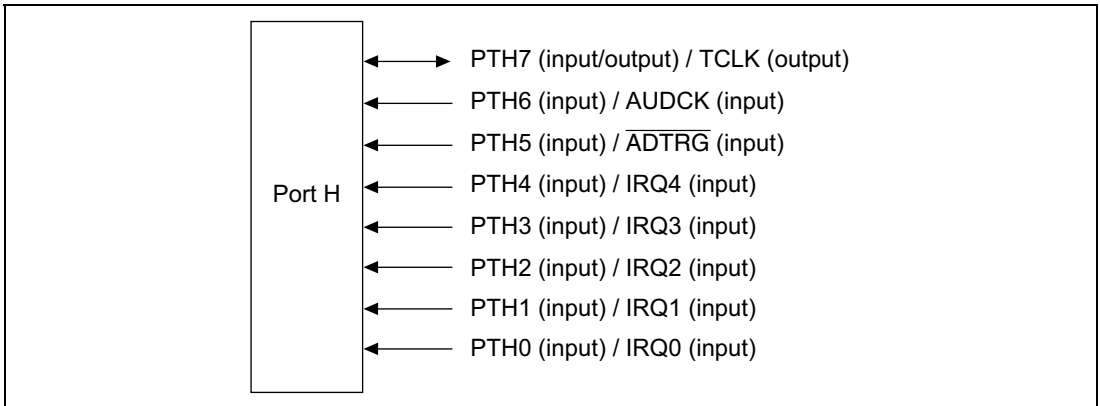

Figure 19.8 Port H

19.9.1 Register Description

Table 19.15 summarizes the port H register.

Table 19.15 Port H Register

Name	Abbreviation	R/W	Initial Value	Address	Access Size
Port H data register	PHDR	R/W or R	B'0*****	H'0400012E (H'A400012E)*1	8

Notes: This register is located in area 1 of physical space. Therefore, when the cache is on, either access this register from the P2 area of logical space or else make an appropriate setting using the MMU so that this register is not cached.

* Means no value.

*1 When address translation by the MMU does not apply, the address in parentheses should be used.

19.9.2 Port H Data Register (PHDR)

Bit:	7	6	5	4	3	2	1	0
	PH7DT	PH6DT	PH5DT	PH4DT	PH3DT	PH2DT	PH1DT	PH0DT
Initial value:	0	*	*	*	*	*	*	*
R/W:	R/W	R	R	R	R	R	R	R

Note: * Undefined

The port H data register (PHDR) is a 1-bit readable/writable and 7-bit read-only register that stores data for pins PTH7 to PTH0. Bits PH7DT to PH0DT correspond to pins PTH7 to PTH0. When the pin function is general output port, if the port is read, the value of the corresponding PHDR bit is returned directly. When the function is general input port, if the port is read, the corresponding pin level is read. Table 19.16 shows the function of PHDR.

PHDR is initialized to B'0***** by a power-on reset, after which the general input port function (pull-up MOS on) is set as the initial pin function, and the corresponding pin levels are read. It retains its previous value in standby mode and sleep mode, and in a manual reset.

Note that the low level is read if bits 6 to 0 are read except in general-purpose input.

Table 19.16 Port H Data Register (PHDR) Read/Write Operations

PHnMD1	PHnMD0	Pin State	Read	Write
0	0	Other function (see table 18.1)	PHDR value	Value is written to PHDR, but does not affect pin state
	1	Output	PHDR value	Write value is output from pin
1	0	Input (Pull-up MOS on)	Pin state	Value is written to PHDR, but does not affect pin state
	1	Input (Pull-up MOS off)	Pin state	Value is written to PHDR, but does not affect pin state

(n = 7)

PHnMD1	PHnMD0	Pin State	Read	Write
0	0	Other function (see table 18.1)	Low level	Ignored (no effect on pin state)
	1	Reserved	Low level	Ignored (no effect on pin state)
1	0	Input (Pull-up MOS on)	Pin state	Ignored (no effect on pin state)
	1	Input (Pull-up MOS off)	Pin state	Ignored (no effect on pin state)

(n = 0 to 6)

19.10 Port J

Port J is an 8-bit input/output port with the pin configuration shown in figure 19.9. Each pin has an input pull-up MOS, which is controlled by the port J control register (PJCR) in the PFC.

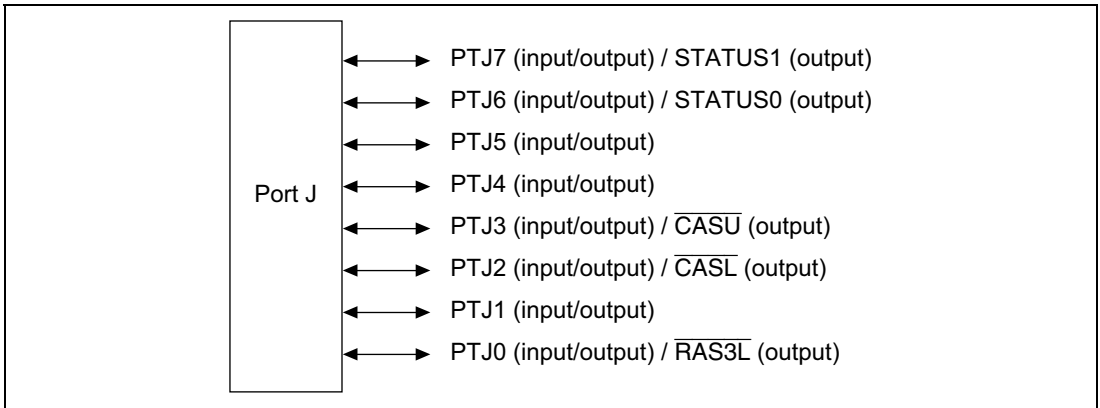

Figure 19.9 Port J

19.10.1 Register Description

Table 19.17 summarizes the port J register.

Table 19.17 Port J Register

Name	Abbreviation	R/W	Initial Value	Address	Access Size
Port J data register	PJDR	R/W	H'00	H'04000130 (H'A4000130)*	8

Notes: This register is located in area 1 of physical space. Therefore, when the cache is on, either access this register from the P2 area of logical space or else make an appropriate setting using the MMU so that this register is not cached.

* When address translation by the MMU does not apply, the address in parentheses should be used.

19.10.2 Port J Data Register (PJDR)

Bit:	7	6	5	4	3	2	1	0
	PJ7DT	PJ6DT	PJ5DT	PJ4DT	PJ3DT	PJ2DT	PJ1DT	PJ0DT
Initial value:	0	0	0	0	0	0	0	0
R/W:	R/W	R/W	R/W	R/W	R/W	R/W	R/W	R/W

The port J data register (PJDR) is an 8-bit readable/writable register that stores data for pins PTJ7 to PTJ0. Bits PJ7DT to PJ0DT correspond to pins PTJ7 to PTJ0. When the pin function is general output port, if the port is read the value of the corresponding PJDR bit is returned directly. When the function is general input port, if the port is read, the corresponding pin level is read. Table 19.18 shows the function of PJDR.

PJDR is initialized to H'00 by a power-on reset. It retains its previous value in software standby mode and sleep mode, and in a manual reset.

Table 19.18 Port J Data Register (PJDR) Read/Write Operations

PJnMD1	PJnMD0	Pin State	Read	Write
0	0	Other function (see table 18.1)	PJDR value	Value is written to PJDR, but does not affect pin state
	1	Output	PJDR value	Write value is output from pin
1	0	Input (Pull-up MOS on)	Pin state	Value is written to PJDR, but does not affect pin state
	1	Input (Pull-up MOS off)	Pin state	Value is written to PJDR, but does not affect pin state

(n = 0 to 7)

19.11 Port K

Port K is an 8-bit input/output port with the pin configuration shown in figure 19.10. Each pin has an input pull-up MOS, which is controlled by the port K control register (PKCR) in the PFC.

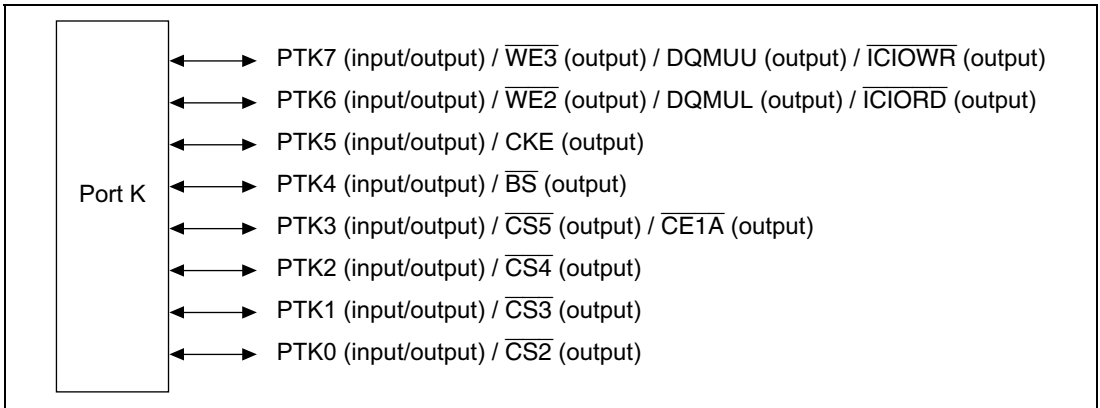

Figure 19.10 Port K

19.11.1 Register Description

Table 19.19 summarizes the port K register.

Table 19.19 Port K Register

Name	Abbreviation	R/W	Initial Value	Address	Access Size
Port K data register	PKDR	R/W	H'00	H'04000132 (H'A4000132)*	8

Notes: This register is located in area 1 of physical space. Therefore, when the cache is on, either access this register from the P2 area of logical space or else make an appropriate setting using the MMU so that this register is not cached.

* When address translation by the MMU does not apply, the address in parentheses should be used.

19.11.2 Port K Data Register (PKDR)

Bit:	7	6	5	4	3	2	1	0
	PK7DT	PK6DT	PK5DT	PK4DT	PK3DT	PK2DT	PK1DT	PK0DT
Initial value:	0	0	0	0	0	0	0	0
R/W:	R/W	R/W	R/W	R/W	R/W	R/W	R/W	R/W

The port K data register (PKDR) is an 8-bit readable/writable register that stores data for pins PTK7 to PTK0. Bits PK7DT to PK0DT correspond to pins PTK7 to PTK0. When the pin function is general output port, if the port is read, the value of the corresponding PKDR bit is returned directly. When the function is general input port, if the port is read, the corresponding pin level is read. Table 19.20 shows the function of PKDR.

PKDR is initialized to H'00 by a power-on reset. It retains its previous value in standby mode and sleep mode, and in a manual reset.

Table 19.20 Port K Data Register (PKDR) Read/Write Operations

PKnMD1	PKnMD0	Pin State	Read	Write
0	0	Other function (see table 18.1)	PKDR value	Value is written to PKDR, but does not affect pin state
	1	Output	PKDR value	Write value is output from pin
1	0	Input (Pull-up MOS on)	Pin state	Value is written to PKDR, but does not affect pin state
	1	Input (Pull-up MOS off)	Pin state	Value is written to PKDR, but does not affect pin state

(n = 0 to 7)

19.12 Port L

Port L is an 8-bit input port with the pin configuration shown in figure 19.11.

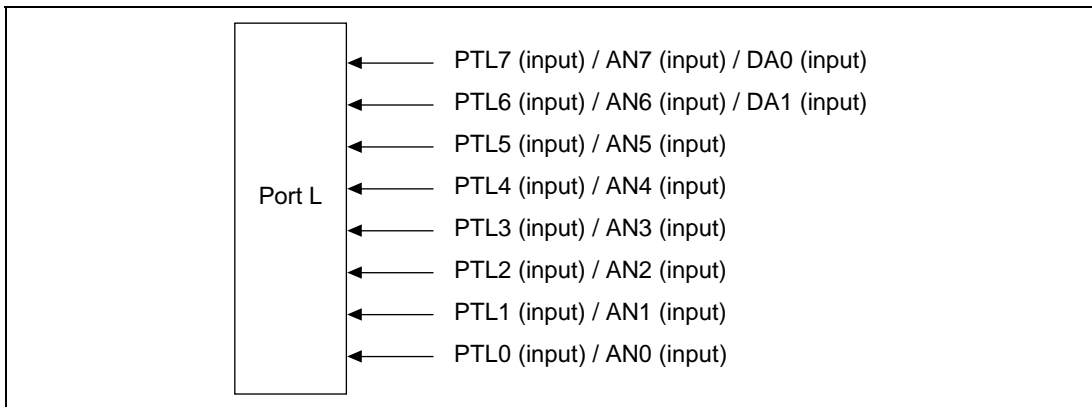

Figure 19.11 Port L

19.12.1 Register Description

Table 19.21 summarizes the port L register.

Table 19.21 Port L Register

Name	Abbreviation	R/W	Initial Value	Address	Access Size
Port L data register	PLDR	R	H'00	H'04000134 (H'A4000134)*	8

Notes: This register is located in area 1 of physical space. Therefore, when the cache is on, either access this register from the P2 area of logical space or else make an appropriate setting using the MMU so that this register is not cached.

* When address translation by the MMU does not apply, the address in parentheses should be used.

19.12.2 Port L Data Register (PLDR)

Bit:	7	6	5	4	3	2	1	0
	PL7DT	PL6DT	PL5DT	PL4DT	PL3DT	PL2DT	PL1DT	PL0DT
Initial value:	0	0	0	0	0	0	0	0
R/W:	R	R	R	R	R	R	R	R

The port L data register (PLDR) is an 8-bit read-only register that stores data for pins PTL7 to PTL0. Bits PL7DT to PL0DT correspond to pins PTL7 to PTL0. When the function is general input port, if the port is read, the corresponding pin level is read. Table 19.22 shows the function of PLDR.

PKDR is initialized to H'00 by power-on reset. It retains its previous value in software standby mode and sleep mode, and in a manual reset.

The port L is also used as an analog pin, therefore does not have a pull-up MOS.

Table 19.22 Port L Data Register (PLDR) Read/Write Operation

PLnMD1	PLnMD0	Pin State	Read	Write
0	0	Other function (see table 18.1)	H'00	Ignored (no effect on pin state)
	1	Reserved	H'00	Ignored (no effect on pin state)
1	0	Input	Pin state	Ignored (no effect on pin state)
	1	Input	Pin state	Ignored (no effect on pin state)

(n = 0 to 7)

19.13 SC Port

The SC port comprises a 4-bit input/output port, 3-bit output port, and 4-bit input port with the pin configuration shown in figure 19.12. Each pin has an input pull-up MOS, which is controlled by the SC port control register (SCPCR) in the PFC.

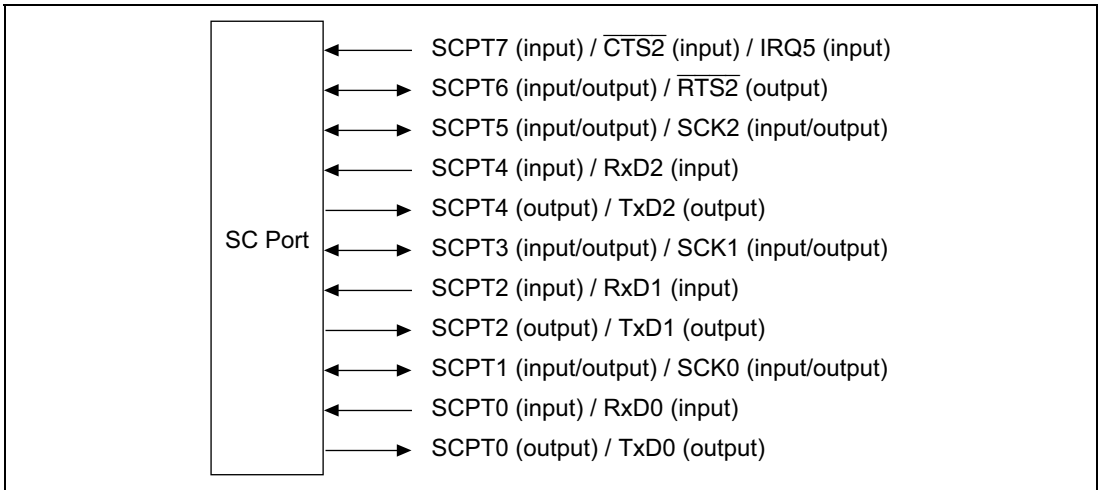

Figure 19.12 SC Port

19.13.1 Register Description

Table 19.23 summarizes the SC port register.

Table 19.23 SC Port Register

Name	Abbreviation	R/W	Initial Value	Address	Access Size
SC Port data register	SCPDR	R/W or R	B'*0000000	H'04000136 (H'A4000136)*1	8

Notes: This register is located in area 1 of physical space. Therefore, when the cache is on, either access this register from the P2 area of logical space or else make an appropriate setting using the MMU so that this register is not cached.

* Means no value.

*1 When address translation by the MMU does not apply, the address in parentheses should be used.

19.13.2 SC Port Data Register (SCPDR)

Bit:	7	6	5	4	3	2	1	0
	SCP7DT	SCP6DT	SCP5DT	SCP4DT	SCP3DT	SCP2DT	SCP1DT	SCP0DT
Initial value:	*	0	0	0	0	0	0	0
R/W:	R	R/W	R/W	R/W	R/W	R/W	R/W	R/W

Note: * Undefined

The SC port data register (SCPDR) is a 7-bit readable/writable and 1-bit read-only register that stores data for pins SCPT7 to SCPT0. Bits SCP7DT to SCP0DT correspond to pins SCPT7 to SCPT0. When the pin function is general output port, if the port is read, the value of the corresponding SCPDR bit is returned directly. When the function is general input port, if the port is read, the corresponding pin level is read. Table 19.24 shows the function of SCPDR.

SCPDR is initialized to B*0000000 by a power-on reset. After initialization, the general input port function (pull-up MOS on) is set as the initial pin function, and the corresponding pin levels are read from bits SCP7DT—SCP5DT, SCP3DT, and SCP1DT. SCPDR retains its previous value in standby mode and sleep mode, and in a manual reset.

Note that the low level is read if bit 7 is read except in general-purpose input.

When the pin states of the RxD2 to RxD0 of the SCP4DT, SCP2DT, and SCP0DT bits in SCPDR are read while the TE and RE bits in SCSCR are not cleared to 0, the RE bit in SCSCR should be set to 1. When the RE bit is set to 1, the RxD pins become an input state and their pin states can be read prior to the SCPCR setting.

Table 19.24 Read/Write Operation of the SC Port Data Register (SCPDR)

SCPnMD1	SCPnMD0	Pin State	Read	Write
0	0	Other function (see table 18.1)	SCPDR value	Value is written to SCPDR, but does not affect pin state
	1	Output	SCPDR value	Write value is output from pin
1	0	Input (Pull-up MOS on)	Pin state	Value is written to SCPDR, but does not affect pin state
	1	Input (Pull-up MOS off)	Pin state	Value is written to SCPDR, but does not affect pin state

(n = 0 to 6)

SCPnMD1	SCPnMD0	Pin State	Read	Write
0	0	Other function (see table 18.1)	Low level	Ignored (no effect on pin state)
	1	Output	Low level	Ignored (no effect on pin state)
1	0	Input (Pull-up MOS on)	Pin state	Ignored (no effect on pin state)
	1	Input (Pull-up MOS off)	Pin state	Ignored (no effect on pin state)

(n = 7)

Section 20 A/D Converter

20.1 Overview

The SH7709S includes a 10-bit successive-approximation A/D converter allowing selection of up to eight analog input channels.

20.1.1 Features

A/D converter features are listed below.

- 10-bit resolution
- Eight input channels
- High-speed conversion
 - Conversion time: maximum 15 μ s per channel ($P\phi = 33$ MHz operation)
- Three conversion modes
 - Single mode: A/D conversion on one channel
 - Multi mode: A/D conversion on one to four channels
 - Scan mode: Continuous A/D conversion on one to four channels
- Four 16-bit data registers
 - A/D conversion results are transferred for storage into data registers corresponding to the channels.
- Sample-and-hold function
- A/D conversion can be externally triggered
- A/D interrupt requested at the end of conversion
 - At the end of A/D conversion, an A/D end interrupt (ADI) can be requested.

20.1.2 Block Diagram

Figure 20.1 shows a block diagram of the A/D converter.

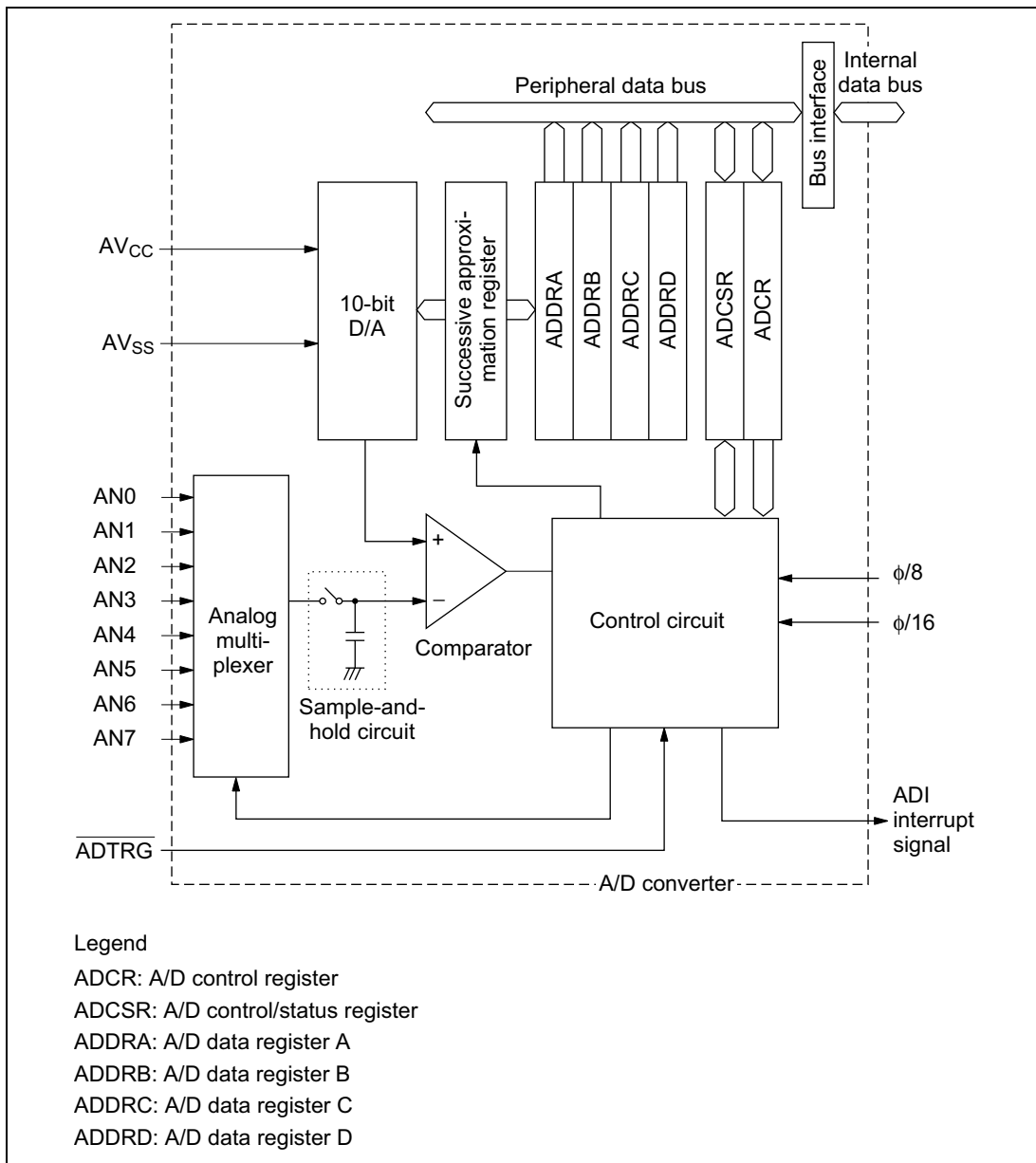

Figure 20.1 Block Diagram of A/D Converter

20.1.3 Input Pins

Table 20.1 summarizes the A/D converter's input pins. The eight analog input pins are divided into two groups: group 0 (AN0 to AN3), and group 1 (AN4 to AN7). AV_{CC} and AV_{SS} are the power supply inputs for the analog circuits in the A/D converter. AV_{CC} also functions as the A/D converter reference voltage pin.

Table 20.1 A/D Converter Pins

Pin Name	Abbreviation	I/O	Function
Analog power supply pin	AV_{CC}	Input	Analog power supply
Analog ground pin	AV_{SS}	Input	Analog ground and reference voltage
Analog input pin 0	AN0	Input	Group 0 analog inputs
Analog input pin 1	AN1	Input	
Analog input pin 2	AN2	Input	
Analog input pin 3	AN3	Input	
Analog input pin 4	AN4	Input	Group1 analog inputs
Analog input pin 5	AN5	Input	
Analog input pin 6	AN6	Input	
Analog input pin 7	AN7	Input	
A/D external trigger input pin	\overline{ADTRG}	Input	External trigger input for starting A/D conversion

20.1.4 Register Configuration

Table 20.2 summarizes the A/D converter's registers.

Table 20.2 A/D Converter Registers

Name	Abbreviation	R/W	Initial Value	Address	Access size
A/D data register AH	ADDRAH	R	H'00	H'04000080 (H'A4000080)*2	16, 8
A/D data register AL	ADDRAL	R	H'00	H'04000082 (H'A4000082)*2	8
A/D data register BH	ADDRBH	R	H'00	H'04000084 (H'A4000084)*2	16, 8
A/D data register BL	ADDRBL	R	H'00	H'04000086 (H'A4000086)*2	8
A/D data register CH	ADDRCH	R	H'00	H'04000088 (H'A4000088)*2	16, 8
A/D data register CL	ADDRCL	R	H'00	H'0400008A (H'A400008A)*2	8
A/D data register DH	ADDRDH	R	H'00	H'0400008C (H'A400008C)*2	16, 8
A/D data register DL	ADDRDL	R	H'00	H'0400008E (H'A400008E)*2	8
A/D control/status register	ADCSR	R/(W)*1	H'00	H'04000090 (H'A4000090)*2	8
A/D control register	ADCR	R/W	H'07	H'04000092 (H'A4000092)*2	8

Notes: These registers are located in area 1 of physical space. Therefore, when the cache is on, either access these registers from the P2 area of logical space or else make an appropriate setting using the MMU so that these registers are not cached.

1. Only 0 can be written to bit 7, to clear the flag.
2. When address translation by the MMU does not apply, the address in parentheses should be used.

20.2 Register Descriptions

20.2.1 A/D Data Registers A to D (ADDRA to ADDR D)

Upper register: H

Bit:	7	6	5	4	3	2	1	0
	AD9	AD8	AD7	AD6	AD5	AD4	AD3	AD2
Initial value:	0	0	0	0	0	0	0	0
R/W:	R	R	R	R	R	R	R	R

Lower register: L

Bit:	7	6	5	4	3	2	1	0
	AD1	AD0	—	—	—	—	—	—
Initial value:	0	0	0	0	0	0	0	0
R/W:	R	R	R	R	R	R	R	R

n = A to D

The four A/D data registers (ADDRA to ADDR D) are 16-bit read-only registers that store the results of A/D conversion.

An A/D conversion produces 10-bit data, which is transferred for storage into the A/D data register corresponding to the selected channel. The upper 8 bits of the result are stored in the upper byte (bits 7 to 0) of the A/D data register. The lower 2 bits are stored in the lower byte (bits 7 and 6). Bits 5 to 0 of an A/D data register are reserved bits that are always read as 0. Table 20.3 indicates the pairings of analog input channels and A/D data registers.

The A/D data registers are initialized to H'0000 by a reset and in standby mode.

Table 20.3 Analog Input Channels and A/D Data Registers

Analog Input Channel		A/D Data Register
Group 0	Group 1	
AN0	AN4	ADDRA
AN1	AN5	ADDRB
AN2	AN6	ADDRC
AN3	AN7	ADDRD

20.2.2 A/D Control/Status Register (ADCSR)

Bit:	7	6	5	4	3	2	1	0
	ADF	ADIE	ADST	MULTI	CKS	CH2	CH1	CH0
Initial value:	0	0	0	0	0	0	0	0
R/W:	R/(W)*	R/W	R/W	R/W	R/W	R/W	R/W	R/W

Note: * Write 0 to clear the flag.

ADCSR is an 8-bit readable/writable register that selects the mode and controls the A/D converter. ADCSR is initialized to H'00 by a reset and in standby mode.

Bit 7—A/D End Flag (ADF): Indicates the end of A/D conversion.

Bit 7: ADF	Description
0	[Clearing conditions] (Initial value) (1) Cleared by reading ADF while ADF = 1, then writing 0 to ADF (2) Cleared when DMAC is activated by ADI interrupt and ADDR is read
1	[Setting conditions] (1) Single mode: A/D conversion ends (2) Multi mode: A/D conversion ends on all selected channels (3) Scan mode: A/D conversion ends on all selected channels

Bit 6—A/D Interrupt Enable (ADIE): Enables or disables the interrupt (ADI) requested at the end of A/D conversion. The ADIE bit should be set while the A/D conversion stops.

Bit 6: ADIE	Description
0	A/D end interrupt request (ADI) is disabled (Initial value)
1	A/D end interrupt request (ADI) is enabled

Bit 5—A/D Start (ADST): Starts or stops A/D conversion. The ADST bit remains set to 1 during A/D conversion. It can also be set to 1 by external trigger input at the $\overline{\text{ADTRG}}$ pin.

Bit 5: ADST	Description
0	A/D conversion is stopped (Initial value)
1	(1) Single mode: A/D conversion starts; ADST is automatically cleared to 0 when conversion ends (2) Multi mode: A/D conversion starts; ADST is automatically cleared to 0 when conversion ends on all selected channels (3) Scan mode: A/D conversion starts and continues, cycling through the selected channels, until ADST is cleared to 0 by software, by a reset, or by a transition to standby mode

Bit 4—Multi Mode (MULTI): Selects single mode, multi mode or scan mode. For further information on operation in these modes, see section 20.4, Operation.

Bit 4: MULTI	ADCR: Bit5: SCN	Description
0	0	Single mode (Initial value)
	1	
1	0	Multi mode
	1	Scan mode

Bit 3—Clock Select (CKS): Selects the A/D conversion time. Clear the ADST bit to 0 before changing the conversion time.

Bit 3:CKS	Description
0	Conversion time = 536 states (maximum) (Initial value)
1	Conversion time = 266 states (maximum)

Bits 2 to 0—Channel Select 2 to 0 (CH2 to CH0): These bits and the MULTI bit select the analog input channels. Clear the ADST bit to 0 before changing the channel selection.

Channel Selection			Description	
CH2	CH1	CH0	Single Mode (MULTI = 0)	Multi Mode and Scan Mode (MULTI = 1)
0	0	0	AN0 (Initial value)	AN0
		1	AN1	AN0, AN1
	1	0	AN2	AN0 to AN2
		1	AN3	AN0 to AN3
1	0	0	AN4	AN4
		1	AN5	AN4, AN5
	1	0	AN6	AN4 to AN6
		1	AN7	AN4 to AN7

20.2.3 A/D Control Register (ADCR)

Bit:	7	6	5	4	3	2	1	0
	TRGE1	TRGE0	SCN	RESVD1	RESVD2	—	—	—
Initial value:	0	0	0	0	0	1	1	1
R/W:	R/W	R/W	R/W	R/W	R/W	R	R	R

ADCR is an 8-bit readable/writable register that enables or disables external triggering of A/D conversion. ADCR is initialized to H'07 by a reset and in standby mode.

Bit 7 and 6—Trigger Enable (TRGE1, TRGE0): Enables or disables external triggering of A/D conversion.

The TRGE1 and TRGE0 bits should only be set when conversion is not in progress.

Bit 7: TRGE1	Bit 6: TRGE0	Description
0	0	A/D conversion does not start when an external trigger is input
0	1	(Initial value)
1	0	A/D conversion starts at the falling edge of an input signal from the external trigger pin ($\overline{\text{ADTRG}}$)
1	1	

Bit 5—Scan Mode (SCN): Selects multi mode or scan mode when the MULTI bit is set to 1. See the description of bit 4 in section 20.2.2, A/D Control/Status Register (ADCSR).

Bits 4 and 3—Reserved (RESVD1, RESVD2): These bits are always read as 0. The write value should always be 0.

Bits 2 to 0—Reserved: These bits are always read as 1. The write value should always be 1.

20.3 Bus Master Interface

ADDRA to ADDR D are 16-bit registers, but they are connected to the bus master by the upper 8 bits of the 16-bit peripheral data bus. Therefore, although the upper byte can be accessed directly by the bus master, the lower byte is read through an 8-bit temporary register (TEMP).

An A/D data register is read as follows. When the upper byte is read, the upper-byte value is transferred directly to the bus master and the lower-byte value is transferred into TEMP. Next, when the lower byte is read, the TEMP contents are transferred to the bus master.

When reading an A/D data register, always read the upper byte before the lower byte. It is possible to read only the upper byte, but if only the lower byte is read, the read value is not guaranteed.

Figure 20.2 shows the data flow for access to an A/D data register.

See section 20.7.3, Access Size and Read Data.

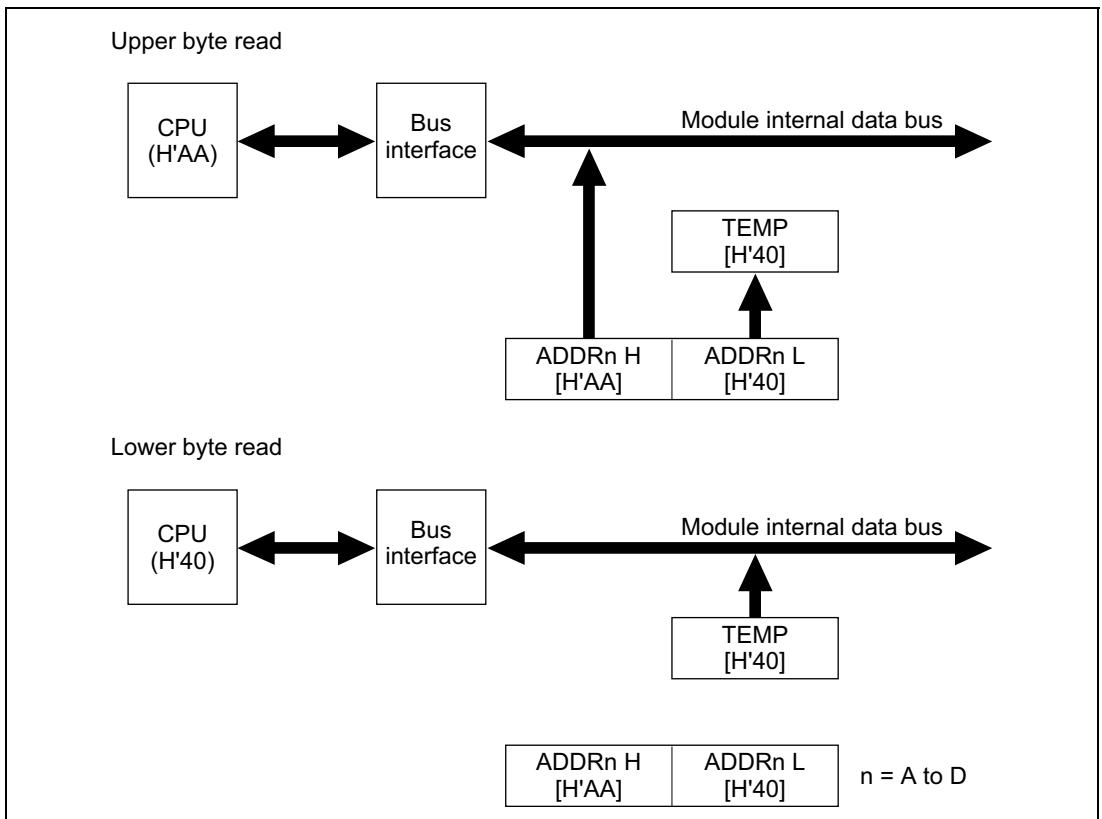

Figure 20.2 A/D Data Register Access Operation (Reading H'AA40)

20.4 Operation

The A/D converter operates by successive approximations with 10-bit resolution. It has three operating modes: single mode, multi mode, and scan mode.

20.4.1 Single Mode (MULTI = 0)

Single mode should be selected when only one A/D conversion on one channel is required. A/D conversion starts when the ADST bit is set to 1 by software, or by external trigger input. The ADST bit remains set to 1 during A/D conversion and is automatically cleared to 0 when conversion ends.

When conversion ends the ADF bit is set to 1. If the ADIE bit is also set to 1, an ADI interrupt is requested at this time. To clear the ADF bit to 0, first read ADF when $ADF = 1$, then write 0 to the ADF bit.

When the mode or analog input channel must be switched during A/D conversion, to prevent incorrect operation, first clear the ADST bit to 0 in ADCSR to halt A/D conversion. After making the necessary changes, set the ADST bit to 1 to start A/D conversion again. The ADST bit can be set at the same time as the mode or channel is changed.

Typical operations when channel 1 (AN1) is selected in single mode are described next.

Figure 20.3 shows a timing diagram for this example. (The ADCSR register specifies bits in the operation example.)

1. Single mode is selected ($MULTI = 0$), input channel AN1 is selected ($CH2 = CH1 = 0, CH0 = 1$), the A/D interrupt is enabled ($ADIE = 1$), and A/D conversion is started ($ADST = 1$).
2. When A/D conversion is completed, the result is transferred into ADDR0. At the same time the ADF flag is set to 1, the ADST bit is cleared to 0, and the A/D converter becomes idle.
3. Since $ADF = 1$ and $ADIE = 1$, an ADI interrupt is requested.
4. The A/D interrupt handling routine starts.
5. The routine reads ADCSR, then writes 0 to the ADF flag.
6. The routine reads and processes the conversion result ($ADDR0 = 0$).
7. Execution of the A/D interrupt handling routine ends. Then, when the ADST bit is set to 1, A/D conversion starts and steps 2 to 7 are executed.

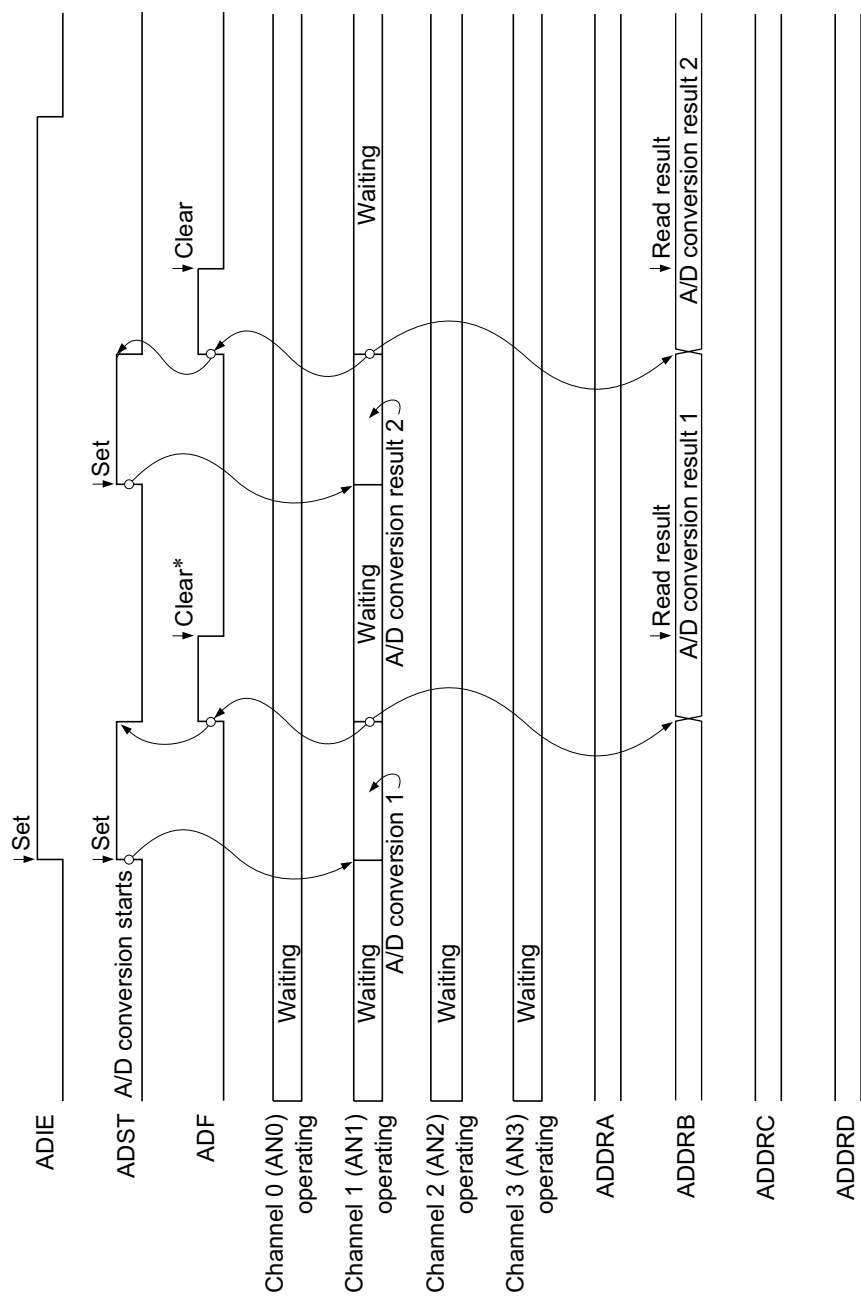

Note: * Vertical arrows (↓) indicate instruction execution by software.

Figure 20.3 Example of A/D Converter Operation (Single Mode, Channel 1 Selected)

20.4.2 Multi Mode (MULTI = 1, SCN = 0)

Multi mode should be selected when performing A/D conversions on one or more channels. When the ADST bit is set to 1 by software or external trigger input, A/D conversion starts on the first channel in the group (AN0 when CH2 = 0, AN4 when CH2 = 1). When two or more channels are selected, after conversion of the first channel ends, conversion of the second channel (AN1 or AN5) starts immediately. When A/D conversions end on the selected channels, the ADST bit is cleared to 0. The conversion results are transferred for storage into the A/D data registers corresponding to the channels.

When the mode or analog input channel selection must be changed during A/D conversion, to prevent incorrect operation, first clear the ADST bit to 0 in ADCSR to halt A/D conversion. After making the necessary changes, set the ADST bit to 1. A/D conversion will start again from the first channel in the group. The ADST bit can be set at the same time as the mode or channel selection is changed.

Typical operations when three channels in group 0 (AN0 to AN2) are selected in scan mode are described next. Figure 20.4 shows a timing diagram for this example.

1. Multi mode is selected (MULTI = 1, SCN = 0), channel group 0 is selected (CH2 = 0), analog input channels AN0 to AN2 are selected (CH1 = 1, CH0 = 0), and A/D conversion is started (ADST = 1).
2. When A/D conversion of the first channel (AN0) is completed, the result is transferred into ADDRA. Next, conversion of the second channel (AN1) starts automatically.
3. Conversion proceeds in the same way through the third channel (AN2).
4. When conversion of all selected channels (AN0 to AN2) is completed, the ADF flag is set to 1 and ADST bit is cleared to 0. If the ADIE bit is set to 1, an ADI interrupt is requested at this time.

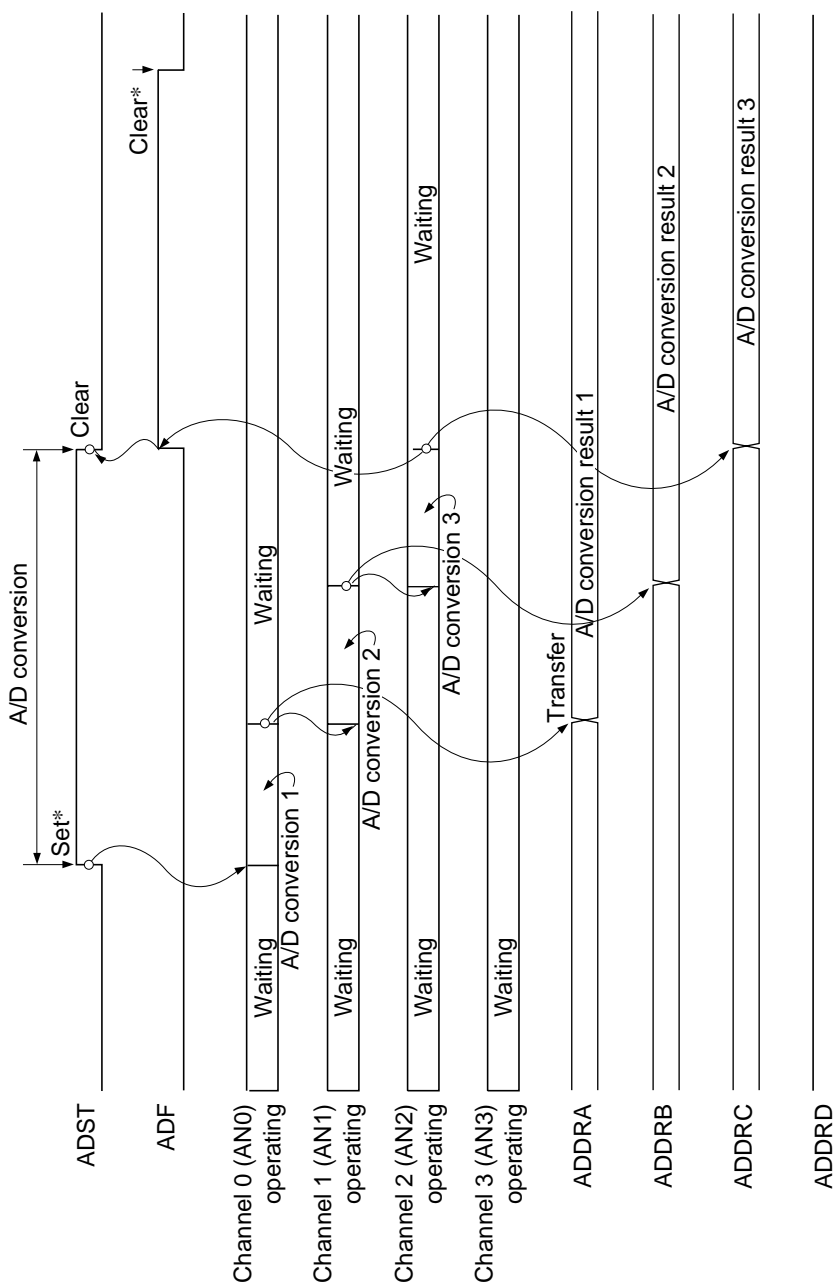

Note: * Vertical arrows (↓) indicate instruction execution by software.

Figure 20.4 Example of A/D Converter Operation (Multi Mode, Channels AN0 to AN2 Selected)

20.4.3 Scan Mode (MULTI = 1, SCN = 1)

Scan mode is useful for monitoring analog inputs in a group of one or more channels. When the ADST bit in the A/D control/status register (ADCSR) is set to 1 by software or external trigger input, A/D conversion starts on the first channel in the group (AN0 when CH2 = 0, AN4 when CH2 = 1). When two or more channels are selected, after conversion of the first channel ends, conversion of the second channel (AN1 or AN5) starts immediately. A/D conversion continues cyclically on the selected channels until the ADST bit is cleared to 0. The conversion results are transferred for storage into the A/D data registers corresponding to the channels.

When the mode or analog input channel must be changed during analog conversion, to prevent incorrect operation, first clear the ADST bit to 0 to halt A/D conversion. After making the necessary changes, set the ADST bit to 1. A/D conversion will start again from the first channel in the group. The ADST bit can be set at the same time as the mode or channel selection is changed.

Typical operations when three channels (AN0 to AN2) in group 0 are selected in scan mode are described next. Figure 20.5 shows a timing diagram for this example.

1. Scan mode is selected (MULTI = 1, SCN = 1), channel group 0 is selected (CH2 = 0), analog input channels AN0 to AN2 are selected (CH1 = 1, CH0 = 0), and A/D conversion is started (ADST = 1).
2. When A/D conversion of the first channel (AN0) is completed, the result is transferred into ADDRA. Next, conversion of the second channel (AN1) starts automatically.
3. Conversion proceeds in the same way through the third channel (AN2).
4. When conversion of all the selected channels (AN0 to AN2) is completed, the ADF flag is set to 1 and conversion of the first channel (AN0) starts again. If the ADIE bit is set to 1, an ADI interrupt is requested at this time.
5. Steps 2 to 4 are repeated as long as the ADST bit remains set to 1. When the ADST bit is cleared to 0, A/D conversion stops. After that, if the ADST bit is set to 1, A/D conversion starts again from the first channel (AN0).

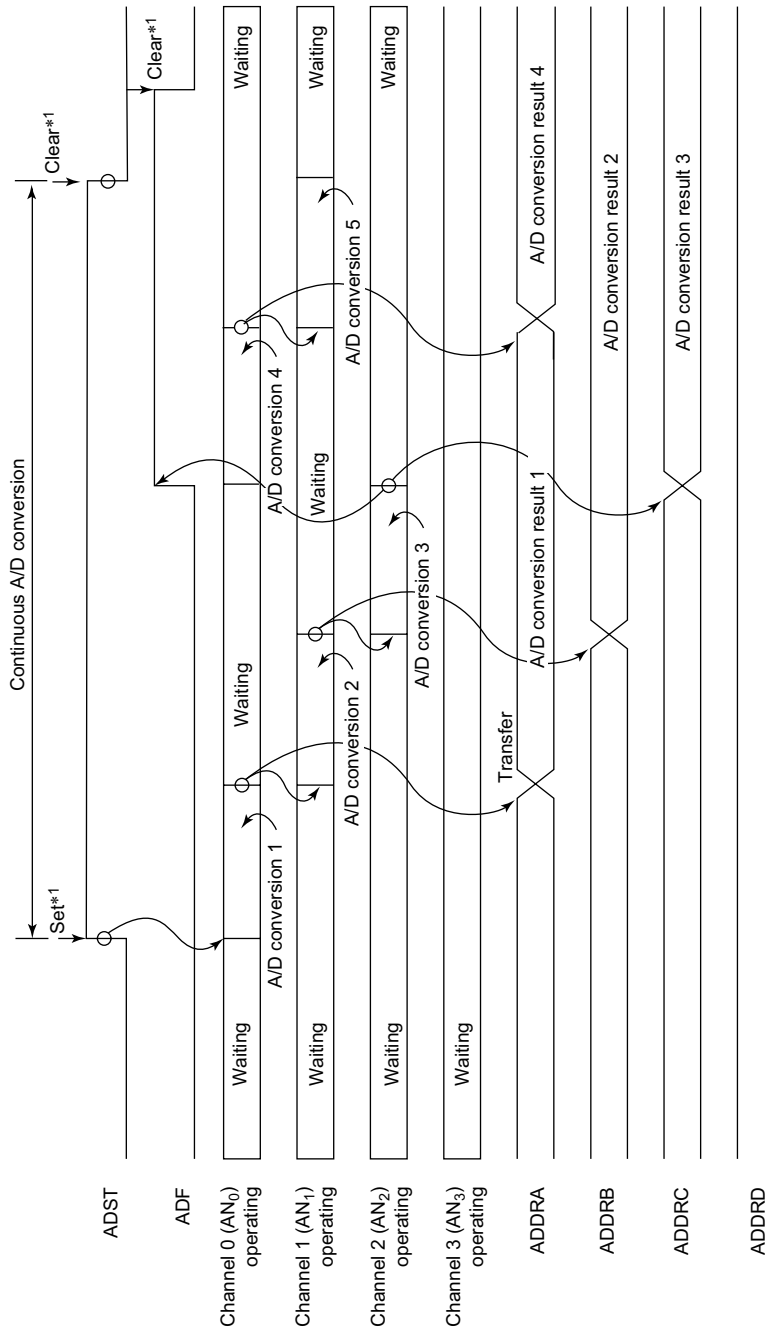

- Notes:
1. Vertical arrows (↓) indicate instruction execution by software.
 2. Data during conversion is ignored.

Figure 20.5 Example of A/D Converter Operation (Scan Mode, Channels AN0 to AN2 Selected)

20.4.4 Input Sampling and A/D Conversion Time

The A/D converter has a built-in sample-and-hold circuit. The A/D converter samples the analog input at a time t_D after the ADST bit is set to 1, then starts conversion. Figure 20.6 shows the A/D conversion timing. Table 20.4 indicates the A/D conversion time.

As indicated in figure 20.6, the A/D conversion time includes t_D and the input sampling time. The length of t_D varies depending on the timing of the write access to ADCSR. The total conversion time therefore varies within the ranges indicated in table 20.4.

In multi mode and scan mode, the conversion time values given in table 20.4 apply to the first conversion. In the second and subsequent conversions, the conversion time is fixed at 512 states when $CKS = 0$ in ADCSR, or 256 states when $CKS = 1$. In both cases, the CKS bit should be set according to the $P\phi$ frequency so that the conversion time is within the range shown in table 23.10 in section 23, Electrical Characteristics.

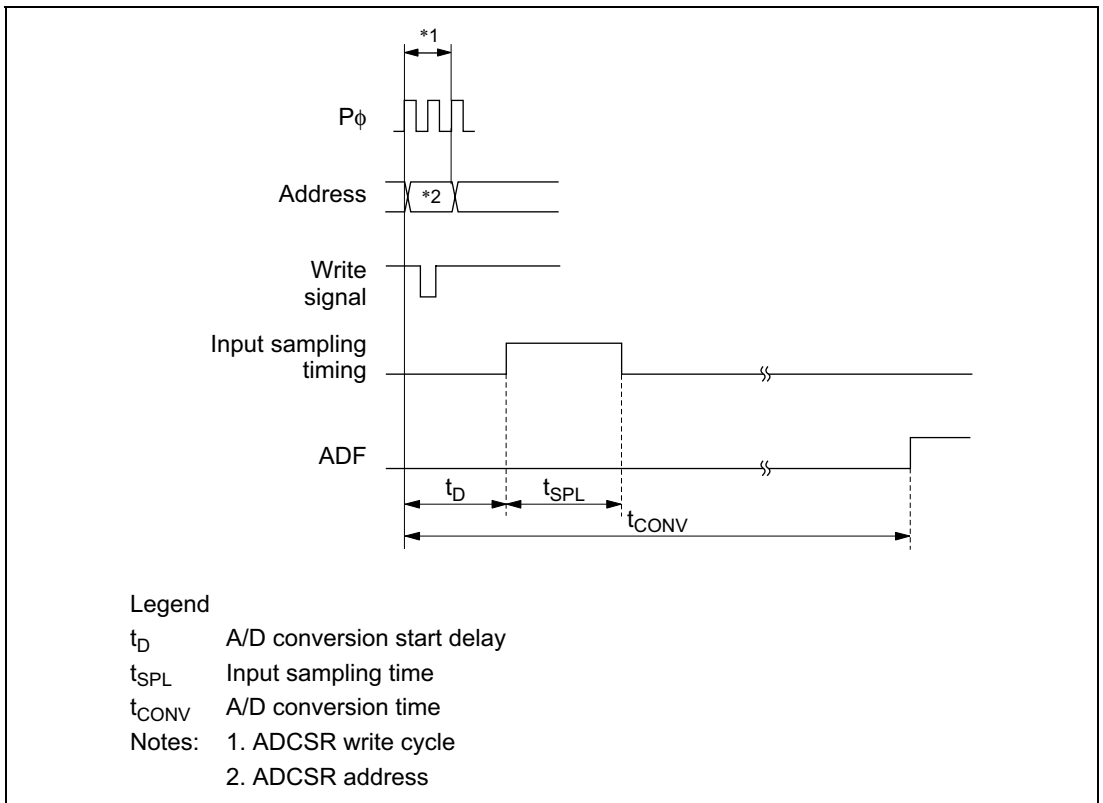

Figure 20.6 A/D Conversion Timing

Table 20.4 A/D Conversion Time (Single Mode)

	Symbol	CKS = 0			CKS = 1		
		Min	Typ	Max	Min	Typ	Max
A/D conversion start delay	t_D	17	—	28	10	—	17
Input sampling time	t_{SPL}	—	129	—	—	65	—
A/D conversion time	t_{CONV}	514	—	525	259	—	266

Note: Values in the table are numbers of states (t_{cyc}).

20.4.5 External Trigger Input Timing

A/D conversion can be externally triggered. When the $\overline{TRGE1}$ and $\overline{TRGE0}$ bits are set to 1 in \overline{ADCR} , external trigger input is enabled at the \overline{ADTRG} pin. A high-to-low transition at the \overline{ADTRG} pin sets the \overline{ADST} bit to 1 in \overline{ADCSR} , starting A/D conversion. Other operations, regardless of the conversion mode, are the same as if the \overline{ADST} bit had been set to 1 by software.

Figure 20.7 shows the timing.

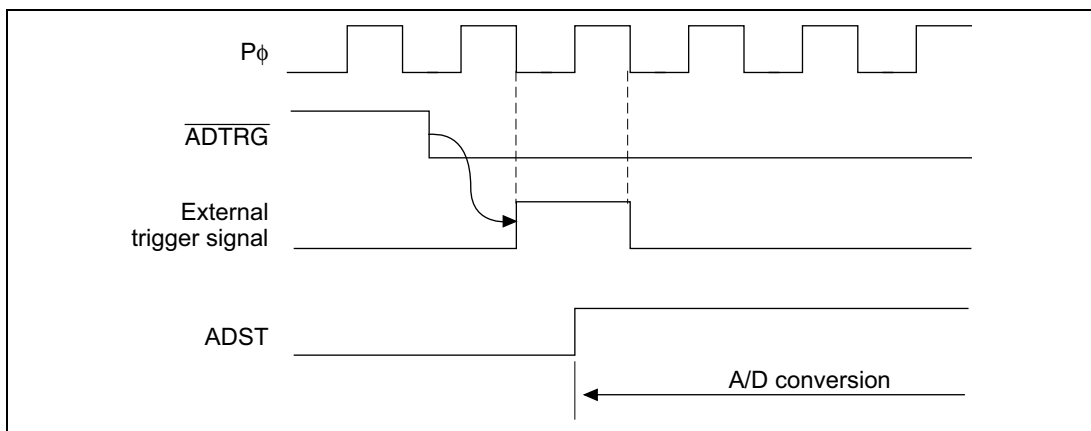

Figure 20.7 External Trigger Input Timing

20.5 Interrupts

The A/D converter generates an interrupt (ADI) at the end of A/D conversion. The ADI interrupt request can be enabled or disabled by the ADIE bit in ADCSR.

20.6 Definitions of A/D Conversion Accuracy

The A/D converter compares an analog value input from an analog input channel with its analog reference value and converts it to 10-bit digital data. The absolute accuracy of this A/D conversion is the deviation between the input analog value and the output digital value. It includes the following errors:

- Offset error
- Full-scale error
- Quantization error
- Nonlinearity error

These four error quantities are explained below with reference to figure 20.8. In the figure, the 10 bits of the A/D converter have been simplified to 3 bits.

Offset error is the deviation between actual and ideal A/D conversion characteristics when the digital output value changes from the minimum (zero voltage) 000000000 (000 in the figure) to 000000001 (001 in the figure)(figure 20.8, item (1)). Full-scale error is the deviation between actual and ideal A/D conversion characteristics when the digital output value changes from the 111111110 (110 in the figure) to the maximum 111111111 (111 in the figure)(figure 20.8, item (2)). Quantization error is the intrinsic error of the A/D converter and is expressed as 1/2 LSB (figure 20.8, item (3)). Nonlinearity error is the deviation between actual and ideal A/D conversion characteristics between zero voltage and full-scale voltage (figure 20.8, item (4)). Note that it does not include offset, full-scale, or quantization error.

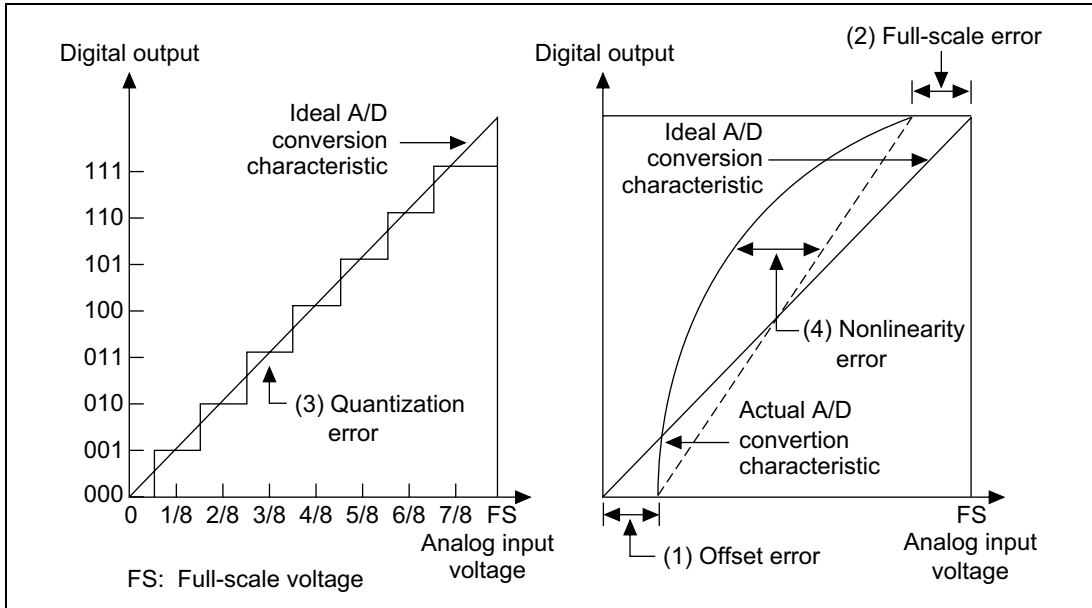

Figure 20.8 Definitions of A/D Conversion Accuracy

20.7 Usage Notes

When using the A/D converter, note the following points.

20.7.1 Setting Analog Input Voltage

- Analog Input Voltage Range: During A/D conversion, the voltages input to the analog input pins ANn should be in the range $AV_{SS} \leq ANn \leq AV_{CC}$ ($n = 0$ to 7).
- Relationships of AV_{CC} and AV_{SS} : AV_{CC} and AV_{SS} should be related as follows: $AV_{CC} = V_{CC} \pm 0.3 \text{ V}$ and $AV_{SS} = V_{SS}$.

20.7.2 Processing of Analog Input Pins

To prevent damage from voltage surges at the analog input pins (AN0 to AN7), connect an input protection circuit like the one shown in figure 20.9. The circuit shown also includes an CR filter to suppress noise. This circuit is shown as an example; the circuit constants should be selected according to actual application conditions. Table 20.5 lists the analog input pin specifications and figure 20.10 shows an equivalent circuit diagram of the analog input ports.

20.7.3 Access Size and Read Data

Table 20.6 shows the relationship between access size and read data. Note the read data obtained with different access sizes, bus widths, and endian modes.

The case is shown here in which H'3FF is obtained when AV_{CC} is input as an analog input. FF is the data containing the upper 8 bits of the conversion result, and C0 is the data containing the lower 2 bits.

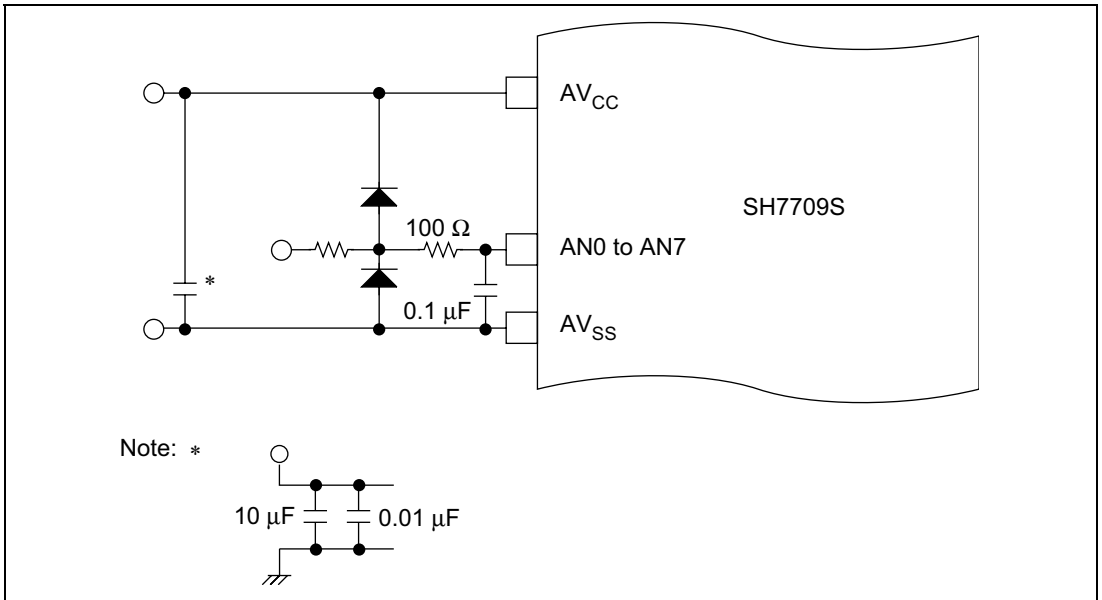

Figure 20.9 Example of Analog Input Protection Circuit

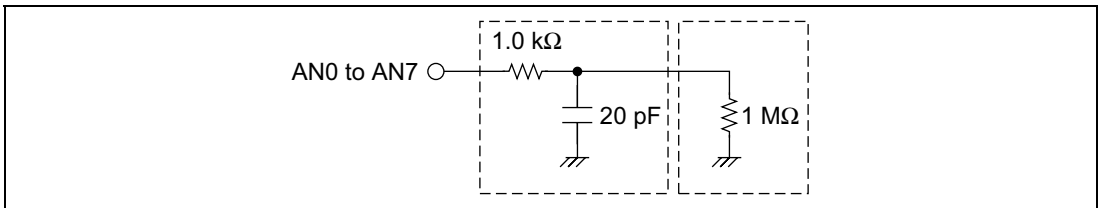

Figure 20.10 Analog Input Pin Equivalent Circuit

Table 20.5 Analog Input Pin Ratings

Item	Min	Max	Unit
Analog input capacitance	—	20	pF
Allowable signal-source impedance	—	5	kΩ

Table 20.6 Relationship between Access Size and Read Data

Access Size	Command	Bus Width					
		32 Bits (D31–D0)		16 Bits (D15–D0)		8 Bits (D7–D0)	
		Endian					
		Big	Little	Big	Little	Big	Little
Byte access	MOV.L#ADDRAH,R9						
	MOV.B@R9,R8	FFFFFFFF	FFFFFFFF	FFFF	FFFF	FF	FF
	MOV.L#ADDRAL,R9						
	MOV.B@R9,R8	C0C0C0C0	C0C0C0C0	C0C0	C0C0	C0	C0
Word access	MOV.L#ADDRAH,R9						
	MOV.W@R9,R8	FFxxFFxx	FFxxFFxx	FFxx	FFxx	FFxx	FF
	MOV.L#ADDRAL,R9						
	MOV.W@R9,R8	C0xxC0xx	C0xxC0xx	C0xx	C0xx	C0xx	xx
Longword access	MOV.L#ADDRAH,R9						
	MOV.L@R9,R8	FFxxC0xx	FFxxC0xx	Ffxx C0xx	C0xx FFxx	FFxx xx C0 xx	xx C0 xx FF
	MOV.L#ADDRAL,R9						
	MOV.L@R9,R8						

In this table: #ADDRAH .EQU H'04000080
 #ADDRAL .EQU H'04000082

Values are shown in hexadecimal for the case where read data is output to an external device via R8.

Section 21 D/A Converter

21.1 Overview

The SH7709S includes a D/A converter with two channels.

21.1.1 Features

D/A converter features are listed below.

- Eight-bit resolution
- Two output channels
- Conversion time: maximum 10 μ s (with 20-pF capacitive load)
- Output voltage: 0 V to AV_{CC}

21.1.2 Block Diagram

Figure 21.1 shows a block diagram of the D/A converter.

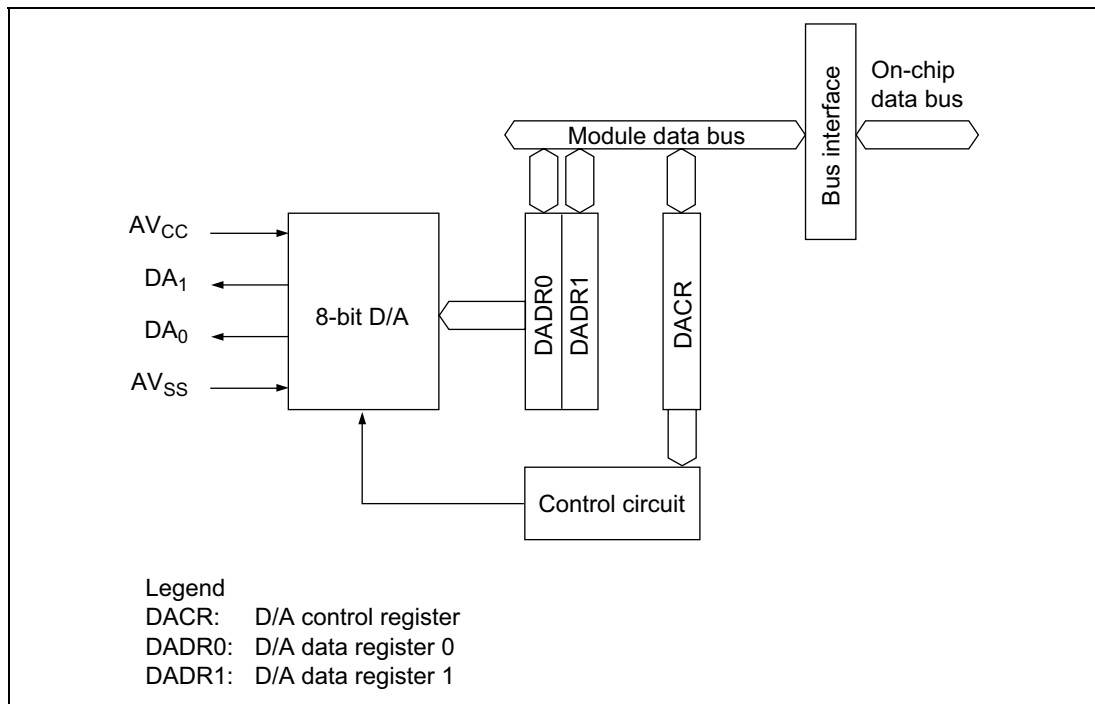

Figure 21.1 Block Diagram D/A Converter

21.1.3 I/O Pins

Table 21.1 summarizes the D/A converter's input and output pins.

Table 21.1 D/A Converter Pins

Pin Name	Abbreviation	I/O	Function
Analog power supply pin	AVcc	Input	Analog power supply
Analog ground pin	AVss	Input	Analog ground and reference voltage
Analog output pin 0	DA0	Output	Analog output, channel 0
Analog output pin 1	DA1	Output	Analog output, channel 1

21.1.4 Register Configuration

Table 21.2 summarizes the D/A converter's registers.

Table 21.2 D/A Converter Registers

Name	Abbreviation	R/W	Initial Value	Address* ¹
D/A data register 0	DADR0	R/W	H'00	H'040000A0 (H'A40000A0)* ²
D/A data register 1	DADR1	R/W	H'00	H'040000A2 (H'A40000A2)* ²
D/A control register	DACR	R/W	H'1F	H'040000A4 (H'A40000A4)* ²

Notes: These registers are located in area 1 of physical space. Therefore, when the cache is on, either access these registers from the P2 area of logical space or else make an appropriate setting using the MMU so that these registers are not cached.

1. Lower 16 bits of the address
2. When address translation by the MMU does not apply, the address in parentheses should be used.

21.2 Register Descriptions

21.2.1 D/A Data Registers 0 and 1 (DADR0/1)

Bit:	7	6	5	4	3	2	1	0
Initial value:	0	0	0	0	0	0	0	0
R/W:	R/W	R/W	R/W	R/W	R/W	R/W	R/W	R/W

The D/A data registers (DADR0 and DADR1) are 8-bit readable/writable registers that store the data to be converted. When analog output is enabled, the D/A data register values are constantly converted and output at the analog output pins.

The D/A data registers are initialized to H'00 by a reset.

21.2.2 D/A Control Register (DACR)

Bit:	7	6	5	4	3	2	1	0
	DAOE1	DAOE0	DAE	—	—	—	—	—
Initial value:	0	0	0	1	1	1	1	1
R/W:	R/W	R/W	R/W	R	R	R	R	R

DACR is an 8-bit readable/writable register that controls the operation of the D/A converter. DACR is initialized to H'1F by a reset.

Bit 7—D/A Output Enable 1 (DAOE1): Controls D/A conversion and analog output.

Bit 7: DAOE1 Description

0	DA1 analog output is disabled	(Initial value)
1	Channel-1 D/A conversion and DA1 analog output are enabled	

Bit 6—D/A Output Enable 0 (DAOE0): Controls D/A conversion and analog output.

Bit 6: DAOE0 Description

0	DA0 analog output is disabled	(Initial value)
1	Channel-0 D/A conversion and DA0 analog output are enabled	

Bit 5—D/A Enable (DAE): Controls D/A conversion, together with bits DAOE0 and DAOE1. When the DAE bit is cleared to 0, D/A conversion is controlled independently in channels 0 and 1. When the chip enters standby mode while D/A conversion is enabled, the D/A output is held and the analog power-supply current is equivalent to that during D/A conversion. To reduce the analog power-supply current in standby mode, clear the DAOE0 and DAOE1 bits and disable the D/A output.

Bit 7: DAOE1	Bit 6: DAOE0	Bit 5: DAE	Description
0	0	—	D/A conversion is disabled in channels 0 and 1 (Initial value)
0	1	0	D/A conversion is enabled in channel 0 D/A conversion is disabled in channel 1
0	1	1	D/A conversion is enabled in channels 0 and 1
1	0	0	D/A conversion is disabled in channel 0 D/A conversion is enabled in channel 1
1	0	1	D/A conversion is enabled in channels 0 and 1
1	1	—	D/A conversion is enabled in channels 0 and 1

When the DAE bit is set to 1, even if bits DAOE0 and DAOE1 in DACR and the ADST bit in ADCSR are cleared to 0, the same current is drawn from the analog power supply as during A/D and D/A conversion.

Bits 4 to 0—Reserved: Read-only bits, always read as 1.

21.3 Operation

The D/A converter has two built-in D/A conversion circuits that can perform conversion independently.

D/A conversion is performed constantly while enabled in DACR. If the DADR0 or DADR1 value is modified, conversion of the new data begins immediately. The conversion results are output when bits DAOE0 and DAOE1 are set to 1.

An example of D/A conversion on channel 0 is given next. Timing is indicated in figure 21.2.

1. Data to be converted is written in DADR0.
2. Bit DAOE0 is set to 1 in DACR. D/A conversion starts and DA0 becomes an output pin. The converted result is output after the conversion time. The output value is $(\text{DADR0 contents}/256) \times AV_{cc}$. Output of this conversion result continues until the value in DADR0 is modified or the DAOE0 bit is cleared to 0.
3. If the DADR0 value is modified, conversion starts immediately, and the result is output after the conversion time.
4. When the DAOE0 bit is cleared to 0, DA0 becomes an input pin.

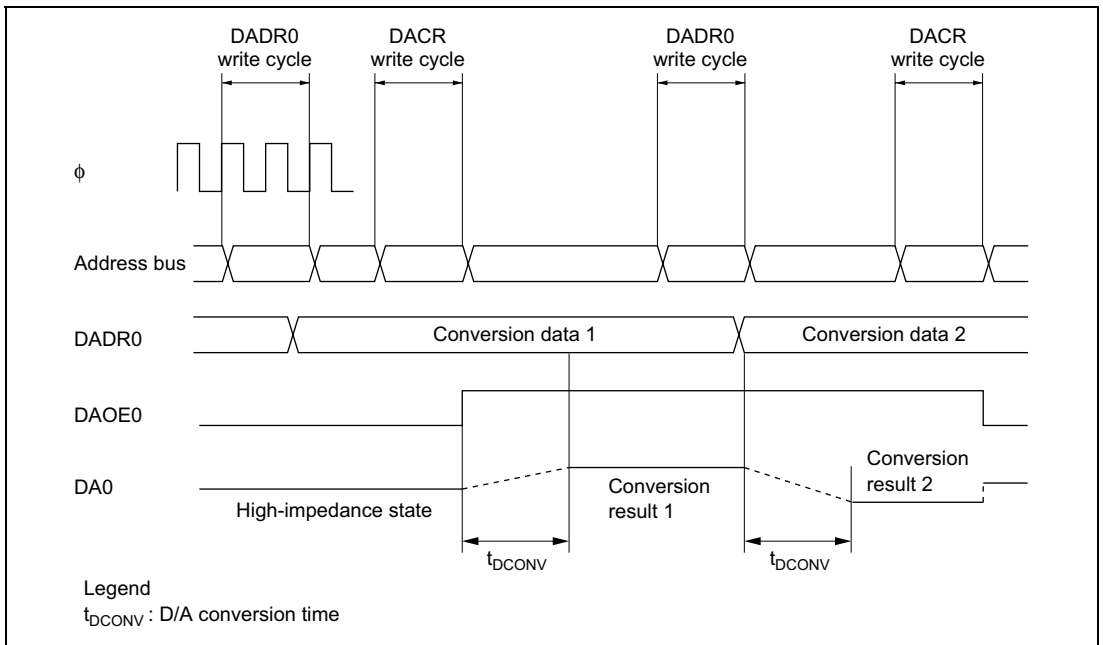

Figure 21.2 Example of D/A Converter Operation

Section 22 User Debugging Interface (UDI)

22.1 Overview

This LSI incorporates a User debugging interface (UDI) and advanced user debugger (AUD) for program debugging.

22.2 User Debugging Interface (UDI)

The UDI (User debugging interface) performs on-chip debugging which is supported by this LSI. The UDI described here is a serial interface which is compatible with JTAG (Joint Test Action Group, IEEE Standard 1149.1 and IEEE Standard Test Access Port and Boundary-Scan Architecture) specifications.

The UDI in the SH7709S supports a boundary scan mode, and is also used for emulator connection.

When using an emulator, UDI functions should not be used. Refer to the emulator manual for the method of connecting the emulator.

22.2.1 Pin Descriptions

TCK: UDI serial data input/output clock pin. Data is serially supplied to the UDI from the data input pin (TDI), and output from the data output pin (TDO), in synchronization with this clock.

TMS: Mode select input pin. The state of the TAP control circuit is determined by changing this signal in synchronization with TCK. The protocol complies with the JTAG standard (IEEE Std. 1149.1).

$\overline{\text{TRST}}$: UDI reset input pin. Input is accepted asynchronously with respect to TCK, and when low, the UDI is reset. See section 22.4.2, Reset Configuration, for more information.

TDI: UDI serial data input pin. Data transfer to the UDI is executed by changing this signal in synchronization with TCK.

TDO: UDI serial data output pin. Data output from the UDI is executed by reading this signal in synchronization with TCK.

$\overline{\text{ASEMD0}}$: ASE mode select pin. If a low level is input at the $\overline{\text{ASEMD0}}$ pin while the $\overline{\text{RESETP}}$ pin is asserted, ASE mode is entered; if a high level is input, normal mode is entered. When using on the user system alone, without an emulator and the UDI, hold this pin at high level. In ASE

mode, boundary scan and emulator functions can be used. The input level at the $\overline{\text{ASEMD0}}$ pin should be held for at least one cycle after $\overline{\text{RESETP}}$ negation.

$\overline{\text{ASEBRKAK}}$: Dedicated emulator pin

22.2.2 Block Diagram

Figure 22.1 shows a block diagram of the UDI.

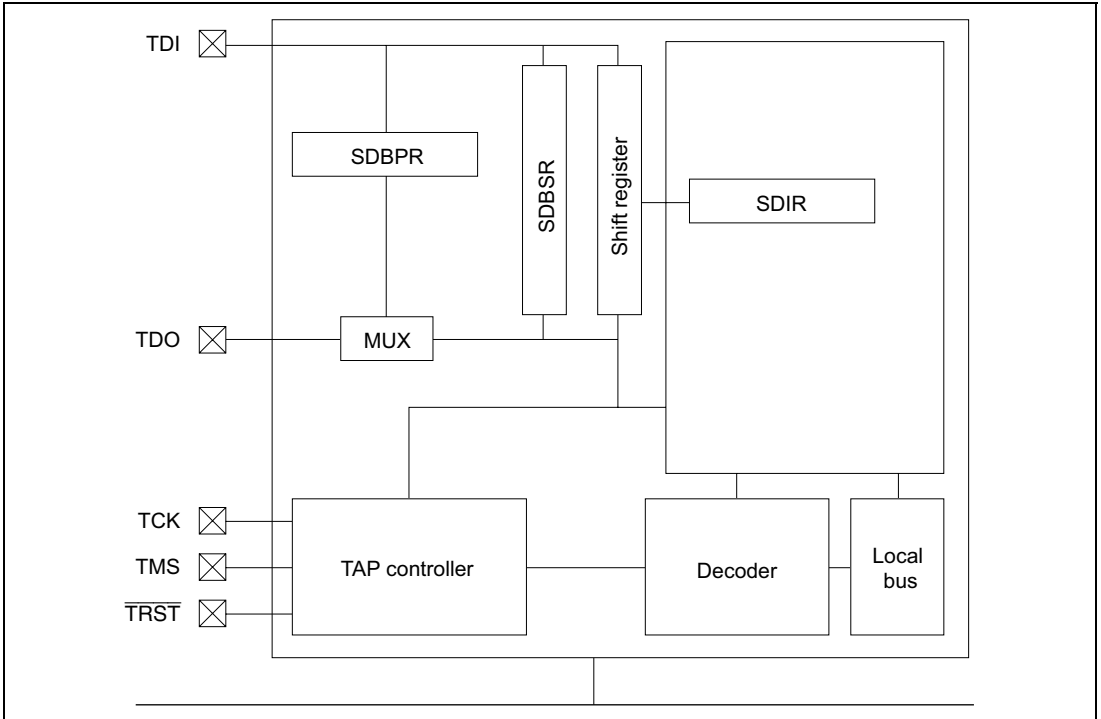

Figure 22.1 Block Diagram of UDI

22.3 Register Descriptions

The UDI has the following registers.

- SDBPR: Bypass register
- SDIR: Instruction register
- SDBSR: Boundary scan register

Table 22.1 shows the UDI register configuration.

Table 22.1 UDI Registers

Name	Abbreviation	CPU Side			UDI Side		Initial Value*
		R/W	Size	Address	R/W	Size	
Bypass register	SDBPR	—	—	—	R/W	1	Undefined
Instruction register	SDIR	R	16	H'04000200	R/W	16	H'FFFF
Boundary register	SDBSR	—	—	—	R/W	—	Undefined

Note: * Initialized when $\overline{\text{TRST}}$ pin is low or when TAP is in the test-logic-reset state.

22.3.1 Bypass Register (SDBPR)

The bypass register is a 1-bit register that cannot be accessed by the CPU. When SDIR is set to the bypass mode, SDBPR is connected between UDI pins TDI and TDO.

22.3.2 Instruction Register (SDIR)

The instruction register (SDIR) is a 16-bit read-only register. The register is in bypass mode in its initial state. It is initialized by $\overline{\text{TRST}}$ assertion or in the TAP test-logic-reset state, and can be written to by the UDI irrespective of the CPU mode. Operation is not guaranteed if a reserved command is set in this register

Bit:	15	14	13	12	11	10	9	8
	TI3	TI2	TI1	TI0	—	—	—	—
Initial value:	1	1	1	1	1	1	1	1
Bit:	7	6	5	4	3	2	1	0
	—	—	—	—	—	—	—	—
Initial value:	1	1	1	1	1	1	1	1

Bits 15 to 12—Test Instruction Bits (TI3 to TI0): Cannot be written by the CPU.

Table 22.2 UDI Commands

Bit 15 to 12				Description
TI3	TI2	TI1	TI0	
0	0	0	0	EXTEST
0	1	0	0	SAMPLE/PRELOAD
0	1	0	1	Reserved
0	1	1	0	UDI reset negate
0	1	1	1	UDI reset assert
1	0	0	—	Reserved
1	0	1	—	UDI interrupt
1	1	0	—	Reserved
1	1	1	0	Reserved
1	1	1	1	Bypass mode (Initial value)
0	0	0	1	Recovery from sleep

Bits 11 to 0—Reserved: These bits are always read as 1.

22.3.3 Boundary Scan Register (SDBSR)

The boundary scan register (SDBSR) is a shift register, located on the PAD, for controlling the input/output pins of the SH7709S.

Using the EXTEST and SAMPLE/PRELOAD commands, a boundary scan test conforming to the JTAG standard can be carried out. Table 22.3 shows the correspondence between the pins of this LSI and boundary scan register bits.

Table 22.3 Pins of this LSI and Boundary Scan Register Bits

Bit	Pin Name	I/O	Bit	Pin Name	I/O
from TDI			308	D1	IN
338	D31/PTB7	IN	307	D0	IN
337	D30/PTB6	IN	306	MD1	IN
336	D29/PTB5	IN	305	MD2	IN
335	D28/PTB4	IN	304	NMI	IN
334	D27/PTB3	IN	303	IRQ0/ $\overline{\text{IRL0}}$ /PTH0	IN
333	D26/PTB2	IN	302	IRQ1/ $\overline{\text{IRL1}}$ /PTH1	IN
332	D25/PTB1	IN	301	IRQ2/ $\overline{\text{IRL2}}$ /PTH2	IN
331	D24/PTB0	IN	300	IRQ3/ $\overline{\text{IRL3}}$ /PTH3	IN
330	D23/PTA7	IN	299	IRQ4/PTH4	IN
329	D22/PTA6	IN	298	D31/PTB7	OUT
328	D21/PTA5	IN	297	D30/PTB6	OUT
327	D20/PTA4	IN	296	D29/PTB5	OUT
326	D19/PTA3	IN	295	D28/PTB4	OUT
325	D18/PTA2	IN	294	D27/PTB3	OUT
324	D17/PTA1	IN	293	D26/PTB2	OUT
323	D16/PTA0	IN	292	D25/PTB1	OUT
322	D15	IN	291	D24/PTB0	OUT
321	D14	IN	290	D23/PTA7	OUT
320	D13	IN	289	D22/PTA6	OUT
319	D12	IN	288	D21/PTA5	OUT
318	D11	IN	287	D20/PTA4	OUT
317	D10	IN	286	D19/PTA3	OUT
316	D9	IN	285	D18/PTA2	OUT
315	D8	IN	284	D17/PTA1	OUT
314	D7	IN	283	D16/PTA0	OUT
313	D6	IN	282	D15	OUT
312	D5	IN	281	D14	OUT
311	D4	IN	280	D13	OUT
310	D3	IN	279	D12	OUT
309	D2	IN	278	D11	OUT

Bit	Pin Name	I/O
277	D10	OUT
276	D9	OUT
275	D8	OUT
274	D7	OUT
273	D6	OUT
272	D5	OUT
271	D4	OUT
270	D3	OUT
269	D2	OUT
268	D1	OUT
267	D0	OUT
266	D31/PTB7	Control
265	D30/PTB6	Control
264	D29/PTB5	Control
263	D28/PTB4	Control
262	D27/PTB3	Control
261	D26/PTB2	Control
260	D25/PTB1	Control
259	D24/PTB0	Control
258	D23/PTA7	Control
257	D22/PTA6	Control
256	D21/PTA5	Control
255	D20/PTA4	Control
254	D19/PTA3	Control
253	D18/PTA2	Control
252	D17/PTA1	Control
251	D16/PTA0	Control
250	D15	Control
249	D14	Control
248	D13	Control

Bit	Pin Name	I/O
247	D12	Control
246	D11	Control
245	D10	Control
244	D9	Control
243	D8	Control
242	D7	Control
241	D6	Control
240	D5	Control
239	D4	Control
238	D3	Control
237	D2	Control
236	D1	Control
235	D0	Control
234	\overline{BS} /PTK4	IN
233	$\overline{WE2}$ /DQMUL/ICIORD/ PTK6	IN
232	$\overline{WE3}$ /DQMUU/ICIORD/ PTK7	IN
231	$\overline{AUDSYNC}$ /PTE7	IN
230	$\overline{CS2}$ /PTK0	IN
229	$\overline{CS3}$ /PTK1	IN
228	$\overline{CS4}$ /PTK2	IN
227	$\overline{CS5}$ /CE1A/PTK3	IN
226	$\overline{CE2A}$ /PTE4	IN
225	$\overline{CE2B}$ /PTE5	IN
224	A0	OUT
223	A1	OUT
222	A2	OUT
221	A3	OUT
220	A4	OUT
219	A5	OUT
218	A6	OUT

Bit	Pin Name	I/O	Bit	Pin Name	I/O
217	A7	OUT	187	$\overline{CS4}/PTK2$	OUT
216	A8	OUT	186	$\overline{CS5}/\overline{CE1A}/PTK3$	OUT
215	A9	OUT	185	$\overline{CS6}/\overline{CE1B}$	OUT
214	A10	OUT	184	$\overline{CE2A}/PTE4$	OUT
213	A11	OUT	183	$\overline{CE2B}/PTE5$	OUT
212	A12	OUT	182	A0	Control
211	A13	OUT	181	A1	Control
210	A14	OUT	180	A2	Control
209	A15	OUT	179	A3	Control
208	A16	OUT	178	A4	Control
207	A17	OUT	177	A5	Control
206	A18	OUT	176	A6	Control
205	A19	OUT	175	A7	Control
204	A20	OUT	174	A8	Control
203	A21	OUT	173	A9	Control
202	A22	OUT	172	A10	Control
201	A23	OUT	171	A11	Control
200	A24	OUT	170	A12	Control
199	A25	OUT	169	A13	Control
198	$\overline{BS}/PTK4$	OUT	168	A14	Control
197	\overline{RD}	OUT	167	A15	Control
196	$\overline{WE0}/DQMLL$	OUT	166	A16	Control
195	$\overline{WE1}/DQMLU/\overline{WE}$	OUT	165	A17	Control
194	$\overline{WE2}/DQMUL/\overline{ICIORD}/PTK6$	OUT	164	A18	Control
193	$\overline{WE3}/DQMUU/\overline{ICIOWR}/PTK7$	OUT	163	A19	Control
192	$\overline{RD}/\overline{WR}$	OUT	162	A20	Control
191	$\overline{AUDSYNC}/PTE7$	OUT	161	A21	Control
190	$\overline{CS0}/MCS0$	OUT	160	A22	Control
189	$\overline{CS2}/PTK0$	OUT	159	A23	Control
188	$\overline{CS3}/PTK1$	OUT	158	A24	Control

Bit	Pin Name	I/O	Bit	Pin Name	I/O
157	A25	Control	127	$\overline{\text{BREQ}}$	IN
156	BS/PTK4	Control	126	$\overline{\text{WAIT}}$	IN
155	$\overline{\text{RD}}$	Control	125	AUDCK/PTH6	IN
154	$\overline{\text{WE0/DQMLL}}$	Control	124	$\overline{\text{IOIS16/PTG7}}$	IN
153	$\overline{\text{WE1/DQMLU/WE}}$	Control	123	$\overline{\text{ASEBRKAK/PTG5}}$	IN
152	$\overline{\text{WE2/DQMUL/ICIORD/PTK6}}$	Control	122	CKIO2/PTG4	IN
151	$\overline{\text{WE3/DQMUU/ICIOWR/PTK7}}$	Control	121	AUDATA3/PTG3	IN
150	$\overline{\text{RD/WR}}$	Control	120	AUDATA2/PTG2	IN
149	$\overline{\text{AUDSYNC/PTE7}}$	Control	119	AUDATA1/PTG1	IN
148	$\overline{\text{CS0/MCS0}}$	Control	118	AUDATA0/PTG0	IN
147	$\overline{\text{CS2/PTK0}}$	Control	117	$\overline{\text{ADTRG/PTH5}}$	IN
146	$\overline{\text{CS3/PTK1}}$	Control	116	$\overline{\text{IRLS3/PTF3/PINT11}}$	IN
145	$\overline{\text{CS4/PTK2}}$	Control	115	$\overline{\text{IRLS2/PTF2/PINT10}}$	IN
144	$\overline{\text{CS5/CE1A/PTK3}}$	Control	114	$\overline{\text{IRLS1/PTF1/PINT9}}$	IN
143	$\overline{\text{CS6/CE1B}}$	Control	113	$\overline{\text{IRLS0/PTF0/PINT8}}$	IN
142	$\overline{\text{CE2A/PTE4}}$	Control	112	MD0	IN
141	$\overline{\text{CE2B/PTE5}}$	Control	111	CKE/PTK5	OUT
140	CKE/PTK5	IN	110	$\overline{\text{RAS3L/PTJ0}}$	OUT
139	$\overline{\text{RAS3L/PTJ0}}$	IN	109	PTJ1	OUT
138	PTJ1	IN	108	$\overline{\text{CASL/PTJ2}}$	OUT
137	$\overline{\text{CASL/PTJ2}}$	IN	107	$\overline{\text{CASU/PTJ3}}$	OUT
136	$\overline{\text{CASU/PTJ3}}$	IN	106	PTJ4	OUT
135	PTJ4	IN	105	PTJ5	OUT
134	PTJ5	IN	104	DACK0/PTD5	OUT
133	DACK0/PTD5	IN	103	DACK1/PTD7	OUT
132	DACK1/PTD7	IN	102	PTE6	OUT
131	PTE6	IN	101	PTE3	OUT
130	PTE3	IN	100	$\overline{\text{RAS3U/PTE2}}$	OUT
129	$\overline{\text{RAS3U/PTE2}}$	IN	99	PTE1	OUT
128	PTE1	IN	98	$\overline{\text{BACK}}$	OUT

Bit	Pin Name	I/O	Bit	Pin Name	I/O
97	ASEBRKAK/PTG5	OUT	65	RxD2/SCPT4	IN
96	AUDATA3/PTG3	OUT	64	WAKEUP/PTD3	IN
95	AUDATA2/PTG2	OUT	63	RESETOUT/PTD2	IN
94	AUDATA1/PTG1	OUT	62	DRAK0/PTD1	IN
93	AUDATA0/PTG0	OUT	61	DRAK1/PTD0	IN
92	CKE/PTK5	Control	60	DREQ0/PTD4	IN
91	RAS3L/PTJ0	Control	59	DREQ1/PTD6	IN
90	PTJ1	Control	58	RxD1/SCPT2	IN
89	CASL/PTJ2	Control	57	CTS2/IRQ5/SCPT7	IN
88	CASU/PTJ3	Control	56	MCS7/PTC7/PINT7	IN
87	PTJ4	Control	55	MCS6/PTC6/PINT6	IN
86	PTJ5	Control	54	MCS5/PTC5/PINT5	IN
85	DACK0/PTD5	Control	53	MCS4/PTC4/PINT4	IN
84	DACK1/PTD7	Control	52	MCS3/PTC3/PINT3	IN
83	PTE6	Control	51	MCS2/PTC2/PINT2	IN
82	PTE3	Control	50	MCS1/PTC1/PINT1	IN
81	RAS3U/PTE2	Control	49	MCS0/PTC0/PINT0	IN
80	PTE1	Control	48	MD3	IN
79	BACK	Control	47	MD4	IN
78	ASEBRKAK/PTG5	Control	46	MD5	IN
77	AUDATA3/PTG3	Control	45	STATUS0/PTJ6	OUT
76	AUDATA2/PTG2	Control	44	STATUS1/PTJ7	OUT
75	AUDATA1/PTG1	Control	43	TCLK/PTH7	OUT
74	AUDATA0/PTG0	Control	42	IRQOUT	OUT
73	STATUS0/PTJ6	IN	41	TxD0/SCPT0	OUT
72	STATUS1/PTJ7	IN	40	SCK0/SCPT1	OUT
71	TCLK/PTH7	IN	39	TxD1/SCPT2	OUT
70	SCK0/SCPT1	IN	38	SCK1/SCPT3	OUT
69	SCK1/SCPT3	IN	37	TxD2/SCPT4	OUT
68	SCK2/SCPT5	IN	36	SCK2/SCPT5	OUT
67	RTS2/SCPT6	IN	35	RTS2/SCPT6	OUT
66	RxD0/SCPT0	IN	34	MCS7/PTC7/PINT7	OUT

22.4 UDI Operation

22.4.1 TAP Controller

Figure 22.2 shows the internal states of the TAP controller. State transitions basically conform with the JTAG standard.

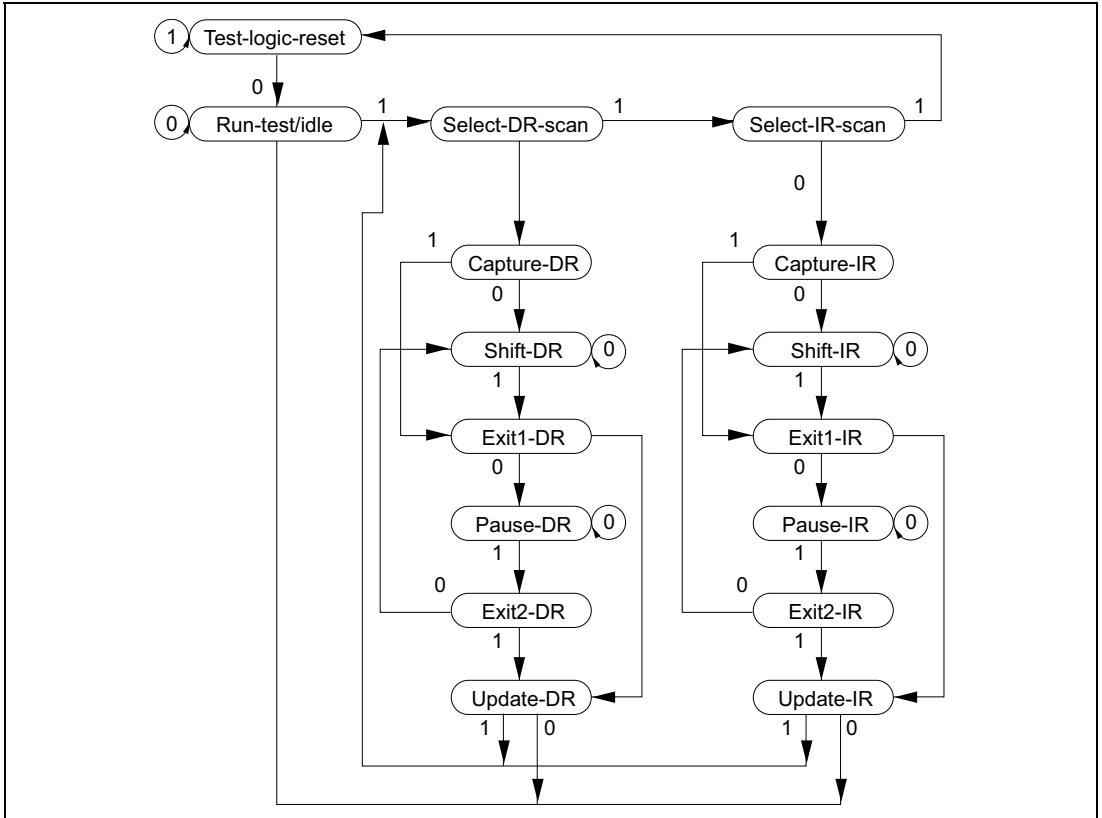

Figure 22.2 TAP Controller State Transitions

Note: The transition condition is the TMS value at the rising edge of TCK. The TDI value is sampled at the rising edge of TCK; shifting occurs at the falling edge of TCK. The TDO value changes at the TCK falling edge. The TDO is at high impedance, except with shift-DR (shift-SR) and shift-IR states. During the change to $\overline{\text{TRST}} = 0$, there is a transition to test-logic-reset asynchronously with TCK.

22.4.2 Reset Configuration

Table 22.4 Reset Configuration

$\overline{\text{ASEMD0}}^{*1}$	$\overline{\text{RESETP}}$	$\overline{\text{TRST}}$	Chip State
High-level	Low-level	Low-level	Normal reset and UDI reset
		High-level	Normal reset
	High-level	Low-level	UDI reset only
		High-level	Normal operation
Low-level	Low-level	Low-level	Reset hold ^{*2}
		High-level	ASE user mode ^{*3} : Normal reset ASE break mode ^{*3} : $\overline{\text{RESETP}}$ assertion masked
	High-level	Low-level	UDI reset only
		High-level	Normal operation

Notes: 1. Selects main chip mode or ASE mode

$\overline{\text{ASEMD0}} = \text{H}$, normal mode

$\overline{\text{ASEMD0}} = \text{L}$, ASE mode

Set $\overline{\text{ASEMD0}} = \text{H}$ when using on the user system alone, without an emulator and the UDI.

2. In ASE mode, reset hold is enabled by driving the $\overline{\text{RESETP}}$ and $\overline{\text{TRST}}$ pins low for a constant cycle. In this state, the CPU does not start up, even if $\overline{\text{RESETP}}$ is driven high. When $\overline{\text{TRST}}$ is driven high, UDI operation is enabled, but the CPU does not start up. The reset hold state is cancelled by the following:
 - Boot request from UDI
 - Another $\overline{\text{RESETP}}$ assert (power-on reset)
3. There are two ASE modes, one for executing software in the emulator's firmware (ASE break mode) and one for executing user software (ASE user mode).

22.4.3 UDI Reset

An UDI reset is executed by setting an UDI reset assert command in SDIR. An UDI reset is of the same kind as a power-on reset. An UDI reset is released by inputting an UDI reset negate command.

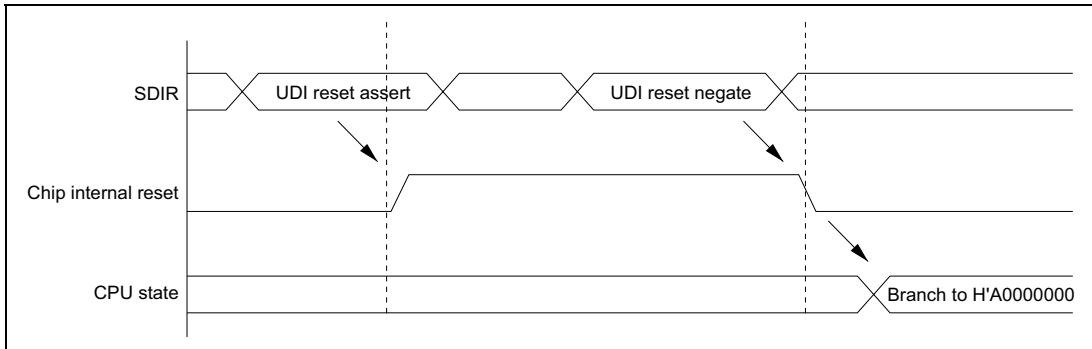

Figure 22.3 UDI Reset

22.4.4 UDI Interrupt

The UDI interrupt function generates an interrupt by setting a command from the UDI in the SDIR. An UDI interrupt is a general exception/interrupt operation, resulting in a branch to an address based on the VBR value plus offset, and with return by the RTE instruction. This interrupt request has a fixed priority level of 15.

UDI interrupts are not accepted in sleep mode or standby mode.

22.4.5 Bypass

The JTAG-based bypass mode for the UDI pins can be selected by setting a command from the UDI in SDIR.

22.4.6 Using UDI to Recover from Sleep Mode

It is possible to recover from sleep mode by setting a command (0001) from the UDI in SDIR.

22.5 Boundary Scan

A command can be set in SDIR by the UDI to place the UDI pins in the boundary scan mode stipulated by JTAG.

22.5.1 Supported Instructions

This LSI supports the three essential instructions defined in the JTAG standard (BYPASS, SAMPLE/PRELOAD, and EXTEST).

BYPASS: The BYPASS instruction is an essential standard instruction that operates the bypass register. This instruction shortens the shift path to speed up serial data transfer involving other chips on the printed circuit board. While this instruction is executing, the test circuit has no effect on the system circuits. The instruction code is 1111.

SAMPLE/PRELOAD: The SAMPLE/PRELOAD instruction inputs values from this LSI's internal circuitry to the boundary scan register, outputs values from the scan path, and loads data onto the scan path. When this instruction is executing, this LSI's input pin signals are transmitted directly to the internal circuitry, and internal circuit values are directly output externally from the output pins. This LSI's system circuits are not affected by execution of this instruction. The instruction code is 0100.

In a SAMPLE operation, a snapshot of a value to be transferred from an input pin to the internal circuitry, or a value to be transferred from the internal circuitry to an output pin, is latched into the boundary scan register and read from the scan path. Snapshot latching is performed in synchronization with the rise of TCK in the Capture-DR state. Snapshot latching does not affect normal operation of this LSI.

In a PRELOAD operation, an initial value is set in the parallel output latch of the boundary scan register from the scan path prior to the EXTEST instruction. Without a PRELOAD operation, when the EXTEST instruction was executed an undefined value would be output from the output pin until completion of the initial scan sequence (transfer to the output latch) (with the EXTEST instruction, the parallel output latch value is constantly output to the output pin).

EXTEST: This instruction is provided to test external circuitry when this LSI is mounted on a printed circuit board. When this instruction is executed, output pins are used to output test data (previously set by the SAMPLE/PRELOAD instruction) from the boundary scan register to the printed circuit board, and input pins are used to latch test results into the boundary scan register from the printed circuit board. If testing is carried out by using the EXTEST instruction N times, the Nth test data is scanned-in when test data (N-1) is scanned out.

Data loaded into the output pin boundary scan register in the Capture-DR state is not used for external circuit testing (it is replaced by a shift operation).

The instruction code is 0000.

22.5.2 Points for Attention

1. Boundary scan mode covers clock-related signals (EXTAL, EXTAL2, XTAL, XTAL2, CKIO).
2. Boundary scan mode does not cover reset-related signals ($\overline{\text{RESETP}}$, $\overline{\text{RESETM}}$, CA).
3. Boundary scan mode does not cover UDI-related signals (TCK, TDI, TDO, TMS, TRST).
4. When a boundary scan test is carried out, ensure that the CKIO clock operates constantly.

The CKIO frequency range is as follows:

Minimum: 1 MHz

Maximum: Maximum frequency for respective clock mode specified in the CPG section

Set pins MD[2:0] to the clock mode to be used.

After powering on, wait for the CKIO clock to stabilize before performing a boundary scan test.

5. Fix the $\overline{\text{RESETP}}$ pin low.
6. Fix the CA pin high, and the $\overline{\text{ASEMD0}}$ pin low.

22.6 Usage Notes

1. An UDI command other than an UDI interrupt, once set, will not be modified as long as another command is not re-issued from the UDI. An UDI interrupt command, however, will be changed to a bypass command once set.
2. Because chip operations are suspended in standby mode, UDI commands are not accepted. However, the TAP controller remains in operation at this time.
3. The UDI is used for emulator connection. Therefore, UDI functions cannot be used when using an emulator.

22.7 Advanced User Debugger (AUD)

The AUD is a function exclusively for use by an emulator. Refer to the User's Manual for the relevant emulator for details of the AUD.

Section 23 Electrical Characteristics

23.1 Absolute Maximum Ratings

Table 23.1 shows the absolute maximum ratings.

Table 23.1 Absolute Maximum Ratings

Item	Symbol	Rating	Unit
Power supply voltage (I/O)	V _{ccQ}	-0.3 to 4.2	V
Power supply voltage (internal)	V _{cc} V _{cc} - PLL1 V _{cc} - PLL2 V _{cc} - RTC	-0.3 to 2.5	V
Input voltage (except port L)	V _{in}	-0.3 to V _{ccQ} + 0.3	V
Input voltage (port L)	V _{in}	-0.3 to AV _{cc} + 0.3	V
Analog power-supply voltage	AV _{cc}	-0.3 to 4.6	V
Analog input voltage	V _{AN}	-0.3 to AV _{cc} + 0.3	V
Operating temperature	T _{opr}	-20 to 75	°C
Storage temperature	T _{str}	-55 to 125	°C

Caution: Operating the chip in excess of the absolute maximum rating may result in permanent damage.

- Order of turning on 1.7 V/1.8 V/1.9 V/2.0 V power (V_{cc}, V_{cc}-PLL1, V_{cc}-PLL2, V_{cc}-RTC) and 3.3 V power (V_{ccQ}, AV_{cc}):
 1. First turn on the 3.3 V power, then turn on the 1.7 V/1.8 V/1.9 V/2.0 V power within 1 ms. This interval should be as short as possible.
 2. Until voltage is applied to all power supplies, a low level is input at the $\overline{\text{RESETP}}$ pin, and CKIO has operated for a maximum of 4 clock cycles, internal circuits remain unsettled, and so pin states are also undefined. The system design must ensure that these undefined states do not cause erroneous system operation. Note that the $\overline{\text{RESETP}}$ pin cannot receive a low level signal while a low level signal is being input to the CA pin.

Waveforms at power-on are shown in the following figure.

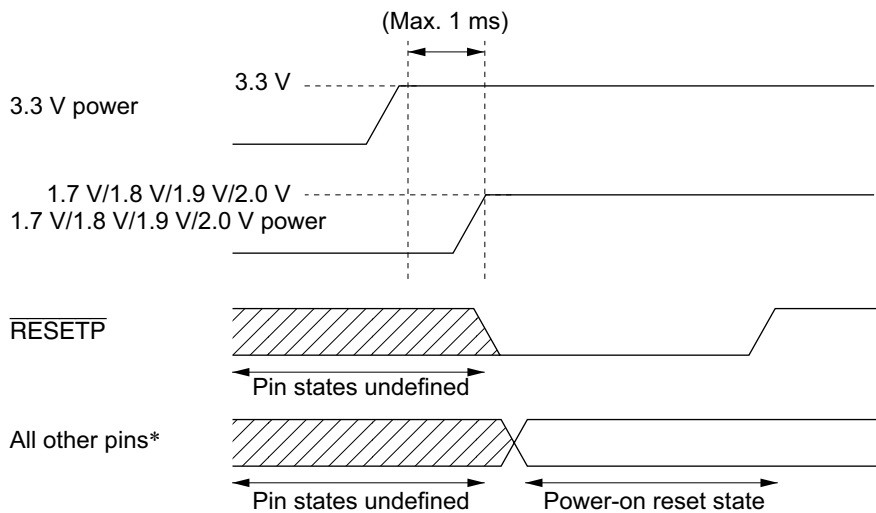

Note: * Except power/GND, clock related, and analog pins

Power-On Sequence

- Power-off order
 1. In the reverse order of powering-on, first turn off the 1.7 V/1.8 V/1.9 V/2.0 V power, then turn off the 3.3 V power within 1 ms. This interval should be as short as possible.
 2. Pin states are undefined while only the 1.7 V/1.8 V/1.9 V/2.0 V power is off. The system design must ensure that these undefined states do not cause erroneous system operation.

23.2 DC Characteristics

Tables 23.2 and 23.3 list DC characteristics.

Table 23.2 DC Characteristics

T_a = -20 to 75°C

Item	Symbol	Min	Typ	Max	Unit	Measurement Conditions	
Power supply voltage	V _{ccQ}	3.0	3.3	3.6	V		
	V _{cc} ,	1.85	2.00	2.15		200 MHz model*	
	V _{cc-PLL1} ,	1.75	1.90	2.05		167 MHz model	
	V _{cc-PLL2} ,	1.65	1.80	2.05		133 MHz model	
	V _{cc-RTC}	1.55	1.70	1.95		100 MHz model	
Current dissipation	Normal operation	I _{cc}	—	410	680	mA	V _{cc} = 2.0 V, I _φ = 200 MHz
			—	330	540		V _{cc} = 1.9 V, I _φ = 167 MHz
			—	250	410		V _{cc} = 1.8 V, I _φ = 133 MHz
			—	190	310		V _{cc} = 1.7 V, I _φ = 100 MHz
			—	20	40		V _{ccQ} = 3.3 V, B _φ = 33 MHz
	Sleep mode* ¹	I _{cc}	—	15	30		* ¹ When there is no other external bus cycle other than the refresh cycle.
			—	10	20		V _{cc} = 1.9 V, V _{ccQ} = 3.3 V B _φ = 33MHz
	Standby mode	I _{cc}	—	40	120	μA	T _a = 25°C (RTC on) V _{ccQ} = 3.3 V, V _{cc} = 1.55 V to 2.15 V
			—	10	30		
		I _{ccQ}	—	290	900		T _a = 25°C (RTC off), Crystal is not used.
			—	10	30		V _{ccQ} = 3.3 V, V _{cc} = 1.55 V to 2.15 V

Item	Symbol	Min	Typ	Max	Unit	Measurement Conditions
Input high voltage	RESETP, RESETM, NMI, IRQ5 to IRQ0, MD5 to MD0, $\overline{\text{IRL3}}$ to $\overline{\text{IRL0}}$, $\overline{\text{IRLS3}}$ to $\overline{\text{IRLS0}}$, PINT15 to PINT0, $\overline{\text{ASEMD0}}$, $\overline{\text{ADTRG}}$, $\overline{\text{TRST}}$, EXTAL, CKIO, RxD1, CA	V_{IH}	—	$V_{\text{CCQ}} + 0.3$	V	
	EXTAL2	—	—	—		When not connecting to a crystal oscillator, connect to Vcc.
	Port L	2.0	—	$A V_{\text{CC}} + 0.3$		
	Other input pins	2.0	—	$V_{\text{CCQ}} + 0.3$		

Item	Symbol	Min	Typ	Max	Unit	Measurement Conditions	
Input low voltage	RESETP, RESETM, NMI, IRQ5–IRQ0, MD5–MD0, IRL3 to IRL0, IRLS3 to IRLS0, PINT15– PINT0, ASEMD0, ADTRG, TRST, EXTAL, CKIO, RxD1, CA	V_{IL}	–0.3	—	V_{CCQ} $\times 0.1$	V	
	EXTAL2	—	—	—		When not connecting to a crystal oscillator, connect to Vcc.	
	Port L	–0.3	—	AV_{CC} $\times 0.2$			
	Other input pins	–0.3	—	V_{CCQ} $\times 0.2$			
Input leak current	All input pins I _{in} I	—	—	1.0	μA	$V_{in} = 0.5$ to $V_{CCQ} - 0.5$ V	
Three-state leak current	I/O, all output pins (off condition)	I _{Isti} I	—	—	1.0	μA	$V_{in} = 0.5$ to $V_{CCQ} - 0.5$ V
Output high voltage	All output pins	V_{OH}	2.4	—	—	V	$V_{CCQ} = 3.0$ V, $I_{OH} = -200$ μA
			2.0	—	—		$V_{CCQ} = 3.0$ V, $I_{OH} = -2$ mA
Output low voltage	All output pins	V_{OL}	—	—	0.55		$V_{CCQ} = 3.6$ V, $I_{OL} = 1.6$ mA
Pull-up resistance	Port pin	R _{pull}	30	60	120	k Ω	
Pin capacity	All pins	C	—	—	10	pF	

Item	Symbol	Min	Typ	Max	Unit	Measurement Conditions
Analog power-supply voltage	AVcc	3.0	3.3	3.6	V	
Analog power-supply current	AIcc	—	0.8	2	mA	
	During A/D and D/A conversion	—	2.4	6	mA	
	Idle	—	1	20	μA	Ta = 25°C

Notes: Even when PLL is not used, always connect Vcc-PLL1 and Vcc-PLL2 to Vcc and connect Vss-PLL1 and Vss-PLL2 to Vss.

Even when RTC is not used, always supply power between Vcc-RTC and Vss-RTC.

AVcc must be under condition of $V_{ccQ} - 0.3 \text{ V} \leq AV_{cc} \leq V_{ccQ} + 0.3 \text{ V}$. If the A/D and D/A converters are not used, do not leave the AVcc and AVss pins open. Connect AVcc to VccQ, and connect AVss to VssQ.

Current dissipation values shown are the values at which all output pins are without load under conditions of $V_{IH \text{ min}} = V_{ccQ} - 0.5 \text{ V}$, $V_{IL \text{ max}} = 0.5 \text{ V}$.

The same voltage should be supplied to Vcc, Vcc-RTC, Vcc-PLL1, and Vcc-PLL2.

* If the IRL and IRLS interrupts are used, the minimum is 1.9 V.

Table 23.3 Permitted Output Current Values

$V_{ccQ} = 3.3 \pm 0.3 \text{ V}$, $V_{cc} = 1.55 \text{ to } 2.15 \text{ V}$, $AV_{cc} = 3.3 \pm 0.3 \text{ V}$, $T_a = -20 \text{ to } 75^\circ\text{C}$

Item	Symbol	Min	Typ	Max	Unit
Output low-level permissible current (per pin)	I_{OL}	—	—	2.0	mA
Output low-level permissible current (total)	$\sum I_{OL}$	—	—	120	mA
Output high-level permissible current (per pin)	$-I_{OH}$	—	—	2.0	mA
Output high-level permissible current (total)	$\sum (-I_{OH})$	—	—	40	mA

Caution: To ensure LSI reliability, do not exceed the value for output current given in table 23.3.

23.3 AC Characteristics

In general, inputting for this LSI should be clock synchronous. Keep the setup and hold times for each input signal unless otherwise specified.

Table 23.4 Operating Frequency Range

$V_{ccQ} = 3.3 \pm 0.3$ V, $V_{ccQ} = 1.55$ to 2.15 V, $AV_{cc} = 3.3 \pm 0.3$ V, $T_a = -20$ to 75°C

Item		Symbol	Min	Typ	Max	Unit	Remarks
Operating frequency	CPU, cache, TLB	f	30	—	200	MHz	200 MHz model
			25		167		167 MHz model
					133		133 MHz model
					100		100 MHz model
External bus			30	—	66.67		200 MHz model
			25				167 MHz model
							133 MHz model
							100 MHz model
Peripheral module			7.5	—	33.34		200 MHz model
			6.25				167 MHz model
							133 MHz model
							100 MHz model

23.3.1 Clock Timing

Table 23.5 Clock Timing

$V_{CCQ} = 3.3 \pm 0.3 \text{ V}$, $V_{CC} = 1.55 \text{ to } 2.15 \text{ V}$, $AV_{CC} = 3.3 \pm 0.3 \text{ V}$, $T_a = -20 \text{ to } 75^\circ\text{C}$

Item	Symbol	Min	Max	Unit	Figure
EXTAL clock input frequency (clock mode 0)	f_{EX}	25	66.67	MHz	23.1
EXTAL clock input cycle time (clock mode 0)	t_{EXcyc}	15	40	ns	
EXTAL clock input frequency (clock mode 1)	f_{EX}	6.25	16.67	MHz	
EXTAL clock input cycle time (clock mode 2)	t_{EXcyc}	60	160	ns	
EXTAL clock input low pulse width	t_{EXL}	1.5	—	ns	
EXTAL clock input high pulse width	t_{EXH}	1.5	—	ns	
EXTAL clock input rise time	t_{EXR}	—	6	ns	
EXTAL clock input fall time	t_{EXF}	—	6	ns	
CKIO clock input frequency	f_{CKI}	20	66	MHz	23.2
CKIO clock input cycle time	t_{CKIcyc}	15.2	40	ns	
CKIO clock input low pulse width	t_{CKIL}	1.5	—	ns	
CKIO clock input high pulse width	t_{CKIH}	1.5	—	ns	
CKIO clock input rise time	t_{CKIR}	—	6	ns	
CKIO clock input fall time	t_{CKIF}	—	6	ns	
CKIO clock output frequency	f_{OP}	25	66	MHz	23.3
CKIO clock output cycle time	t_{cyc}	15.2	40	ns	
CKIO clock output low pulse width	t_{CKOL}	3	—	ns	
CKIO clock output high pulse width	t_{CKOH}	3	—	ns	
CKIO clock output rise time	t_{CKOR}	—	5	ns	
CKIO clock output fall time	t_{CKOF}	—	5	ns	
CKIO2 clock output delay time	t_{CK2D}	-3	3	ns	
CKIO2 clock output rise time	t_{CK20R}	—	7	ns	
CKIO2 clock output fall time	t_{CK20F}	—	7	ns	
Power-on oscillation settling time	t_{OSC1}	10	—	ms	23.4
RESETP setup time	t_{RESPS}	20	—	ns	23.4, 23.5
RESETM setup time	t_{RESMS}	6	—	ns	
RESETP assert time	t_{RESPW}	20	—	t_{cyc}	
RESETM assert time	t_{RESMW}	20	—	t_{cyc}	
Standby return oscillation settling time 1	t_{OSC2}	10	—	ms	23.5
Standby return oscillation settling time 2	t_{OSC3}	10	—	ms	23.6
Standby return oscillation settling time 3	t_{OSC4}	11	—	ms	23.7
PLL synchronization settling time 1 (standby canceled)	t_{PLL1}	100	—	μs	23.8, 23.9
PLL synchronization settling time 2 (multiplication rete modified)	t_{PLL2}	100	—	μs	23.10
IRQ/IRL interrupt determination time (RTC used and standby mode)	t_{IRLSTB}	100	—	μs	23.9

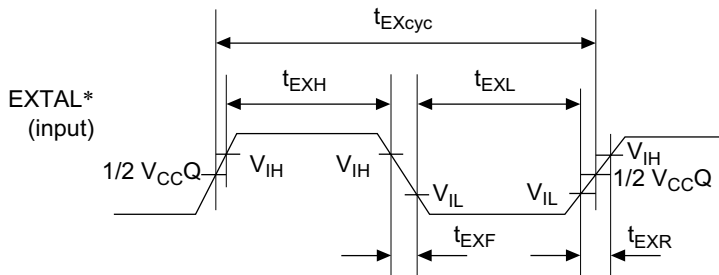

Note: * The clock input from the EXTAL pin.

Figure 23.1 EXTAL Clock Input Timing

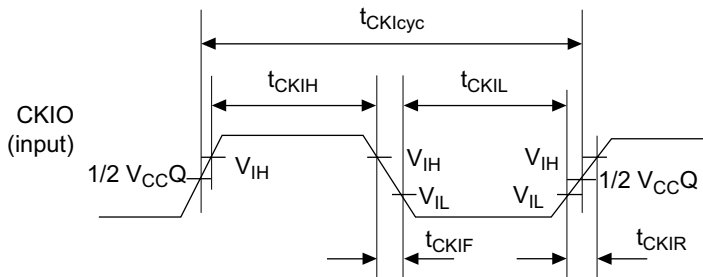

Figure 23.2 CKIO Clock Input Timing

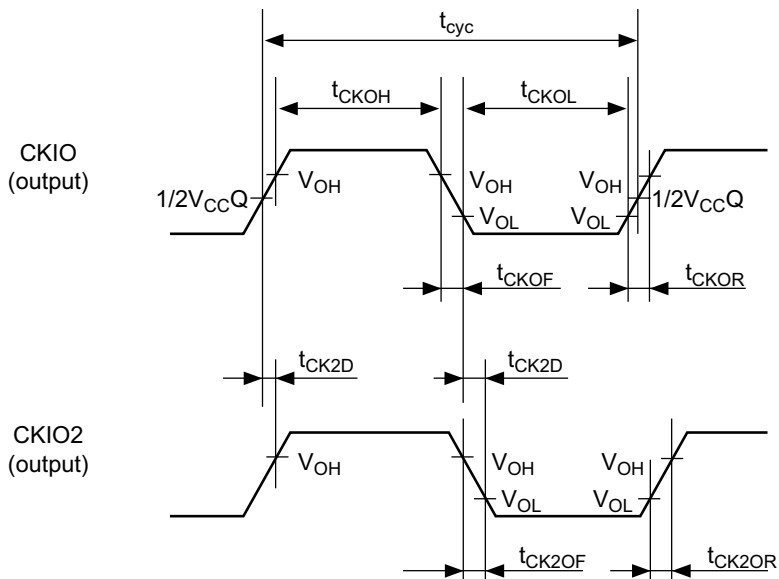

Figure 23.3 CKIO Clock Output Timing

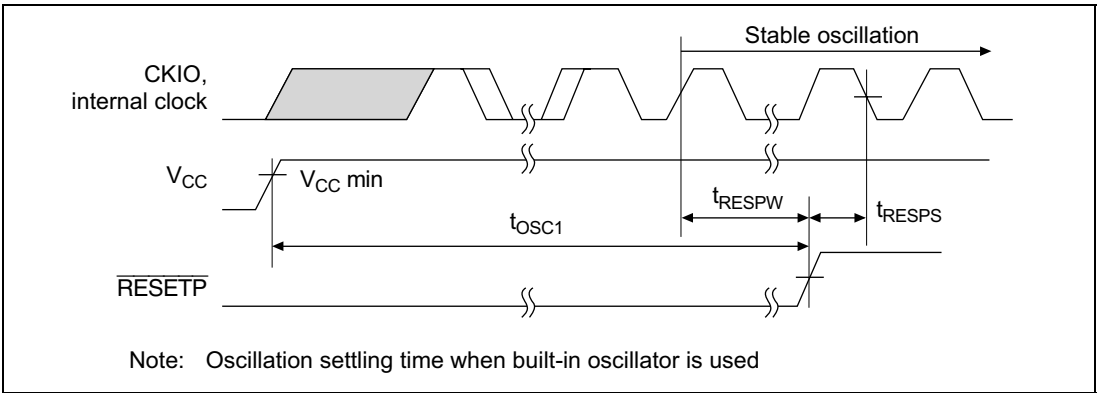

Figure 23.4 Power-on Oscillation Settling Time

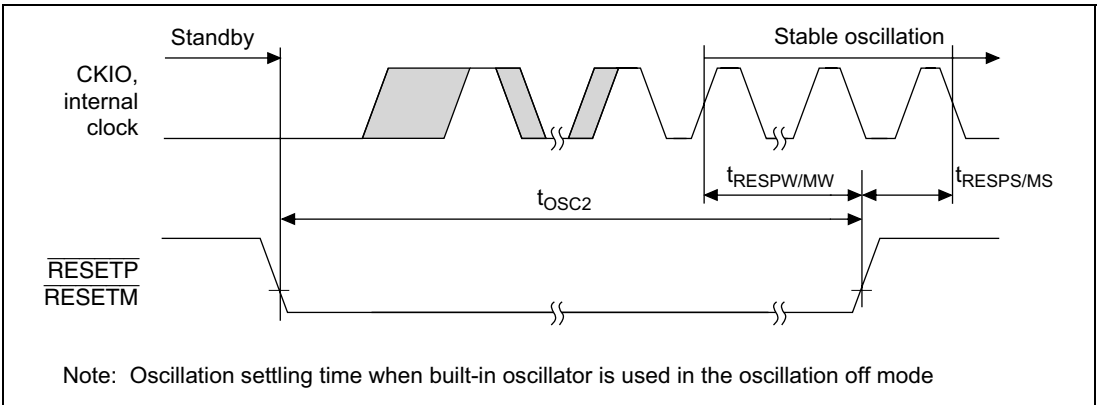
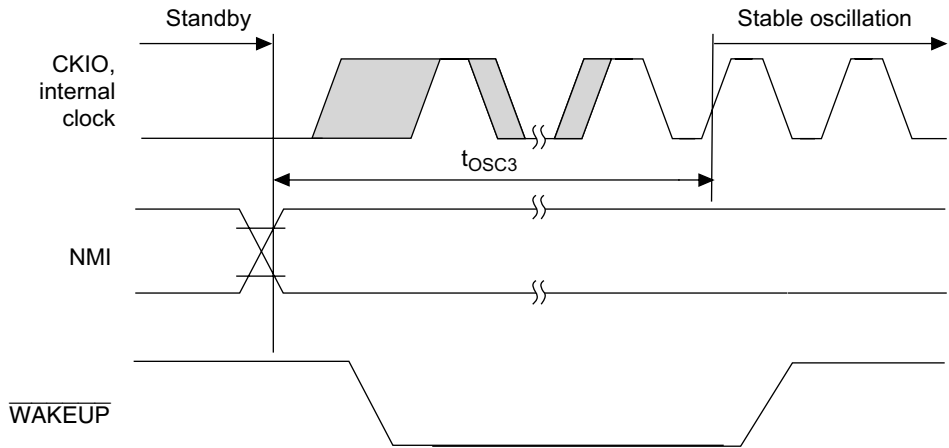
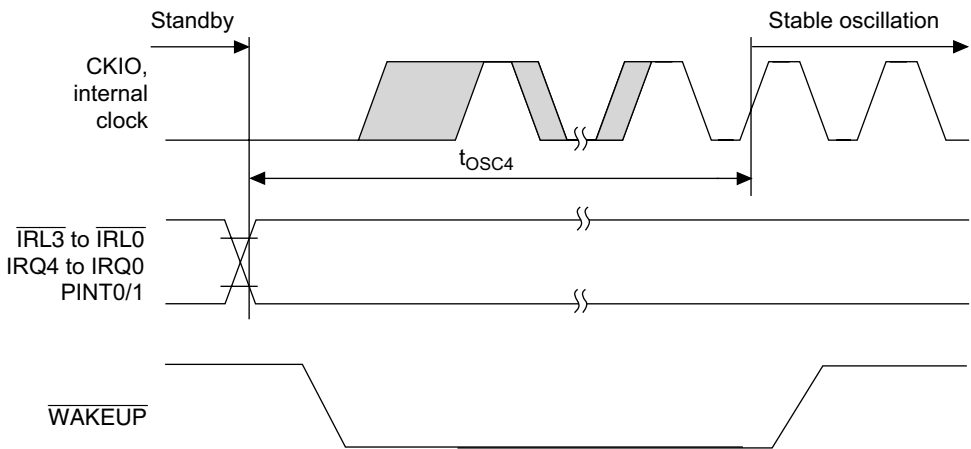

Figure 23.5 Oscillation Settling Time at Standby Return (Return by Reset)



Note: Oscillation settling time when built-in oscillator is used in the oscillation off mode

Figure 23.6 Oscillation Settling Time at Standby Return (Return by NMI)



Note: Oscillation settling time when built-in oscillator is used in the oscillation off mode (only when RTC is used)

Figure 23.7 Oscillation Settling Time at Standby Return (Return by IRQ4 to IRQ0, PINT0/1, IRL3 to IRL0)

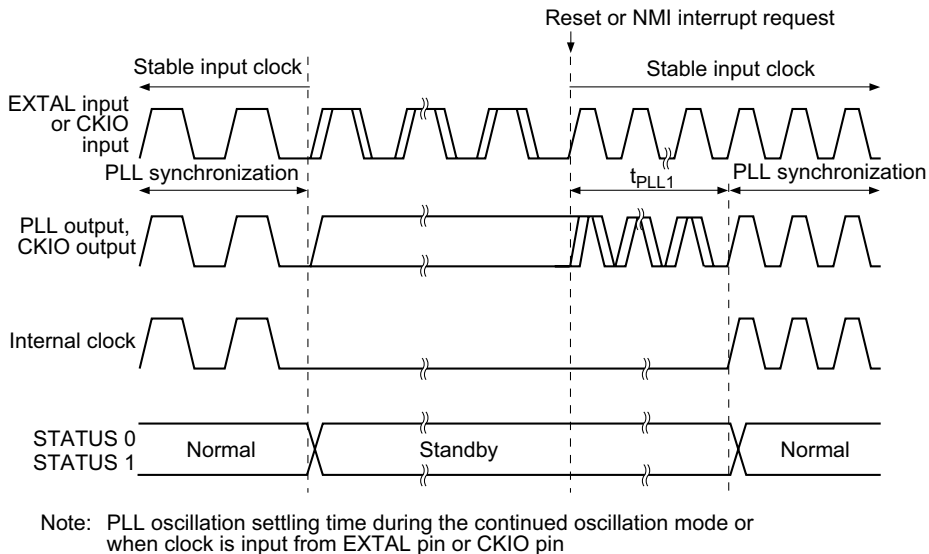

Figure 23.8 PLL Synchronization Settling Time during Standby Recovery (Reset or NMI)

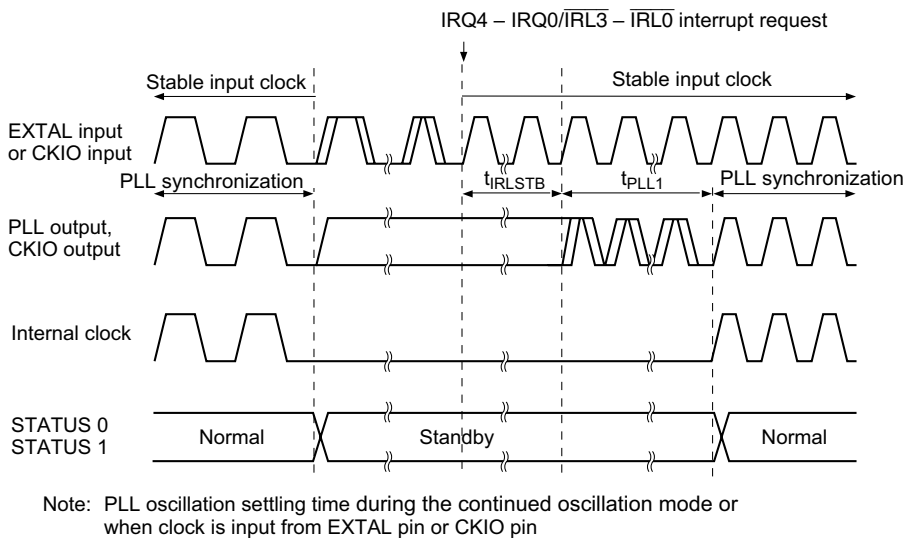
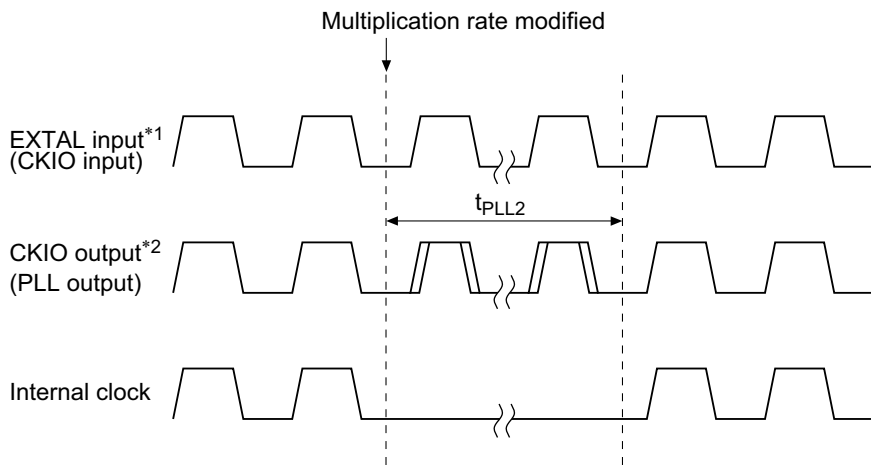

Figure 23.9 PLL Synchronization Settling Time during Standby Recovery (IRQ/IRL or PINT0/PINT1 Interrupt)



- Notes: 1. CKIO input in clock mode 7
 2. PLL output in other than clock mode 7

Figure 23.10 PLL Synchronization Settling Time when Frequency Multiplication Rate Modified

23.3.2 Control Signal Timing

Table 23.6 Control Signal Timing

$V_{CC} = 3.3 \pm 0.3$ V, $V_{CC} = 1.55$ to 2.15 V, $AV_{CC} = 3.3 \pm 0.3$ V, $T_a = -20$ to 75°C

Item	Symbol	Min	Max	Unit	Figure
$\overline{\text{RESETP}}$ pulse width	t_{RESPW}	20 ^{*2}	—	tcyc	23.11,
$\overline{\text{RESETP}}$ setup time ^{*1}	t_{RESPTS}	20	—	ns	23.12
$\overline{\text{RESETP}}$ hold time	t_{RESPH}	4	—	ns	
$\overline{\text{RESETM}}$ pulse width	t_{RESMW}	20 ^{*3}	—	tcyc	
$\overline{\text{RESETM}}$ setup time	t_{RESMS}	6	—	ns	
$\overline{\text{RESETM}}$ hold time	t_{RESMH}	34	—	ns	
$\overline{\text{BREQ}}$ setup time	t_{BREQS}	6	—	ns	23.14
$\overline{\text{BREQ}}$ hold time	t_{BREQH}	4	—	ns	
NMI setup time ^{*1}	t_{NMIS}	10	—	ns	23.12
NMI hold time	t_{NMIH}	4	—	ns	
IRQ5–IRQ0 setup time ^{*1}	t_{IRQS}	10	—	ns	
IRQ5–IRQ0 hold time	t_{IRQH}	4	—	ns	
$\overline{\text{IRQOUT}}$ delay time	t_{IRQOD}	—	10	ns	23.13
$\overline{\text{BACK}}$ delay time	t_{BACKD}	—	10	ns	23.14,
STATUS1, STATUS0 delay time	t_{STD}	—	10	ns	23.15
Bus tri-state delay time 1	t_{BOFF1}	0	15	ns	
Bus tri-state delay time 2	t_{BOFF2}	0	15	ns	
Bus buffer-on time 1	t_{BON1}	0	15	ns	
Bus buffer-on time 2	t_{BON2}	0	15	ns	

- Notes: 1. $\overline{\text{RESETP}}$, NMI, and IRQ5 to IRQ0 are asynchronous. Changes are detected at the clock fall when the setup shown is used. When the setup cannot be used, detection can be delayed until the next clock falls.
2. In the standby mode, $t_{\text{RESPW}} = t_{\text{OSC1}}$ (100 μs) when XTAL oscillation is continued and $t_{\text{RESPW}} = t_{\text{OSC2}}$ (10 ms) when XTAL oscillation is off. In the sleep mode, $t_{\text{RESPW}} = t_{\text{PLL1}}$ (100 μs).
When the clock multiplication ratio is changed, $t_{\text{RESPW}} = t_{\text{PLL1}}$ (100 μs).
3. In the standby mode, $t_{\text{RESMW}} = t_{\text{OSC2}}$ (10 ms). In the sleep mode, $\overline{\text{RESETM}}$ must be kept low until STATUS (0-1) changes to reset (HH). When the clock multiplication ratio is changed, $\overline{\text{RESETM}}$ must be kept low until STATUS (0-1) changes to reset (HH).

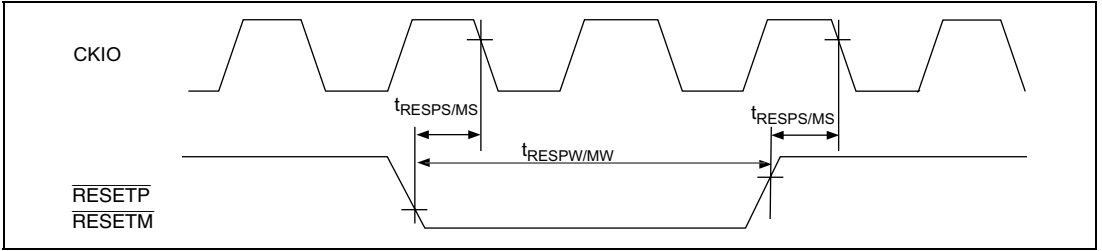

Figure 23.11 Reset Input Timing

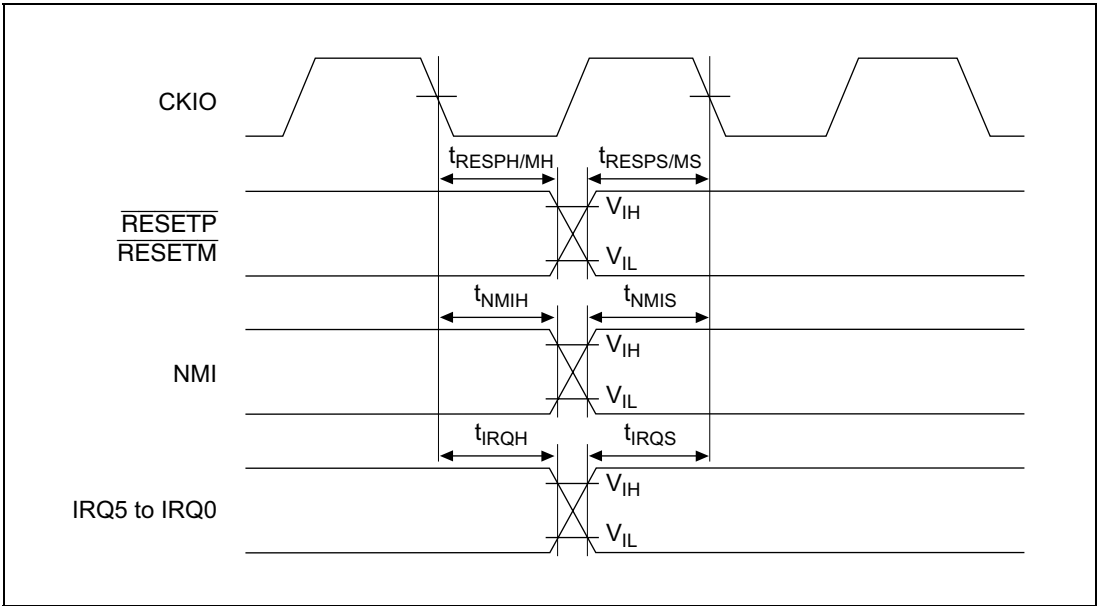

Figure 23.12 Interrupt Signal Input Timing

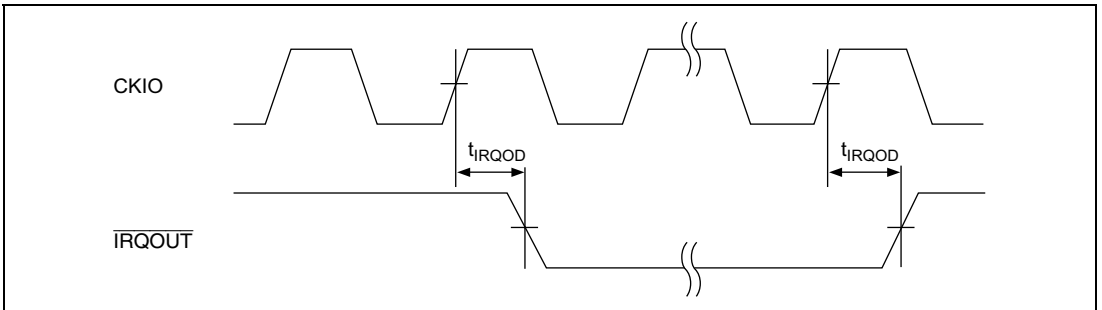

Figure 23.13 $\overline{\text{IRQOUT}}$ Timing

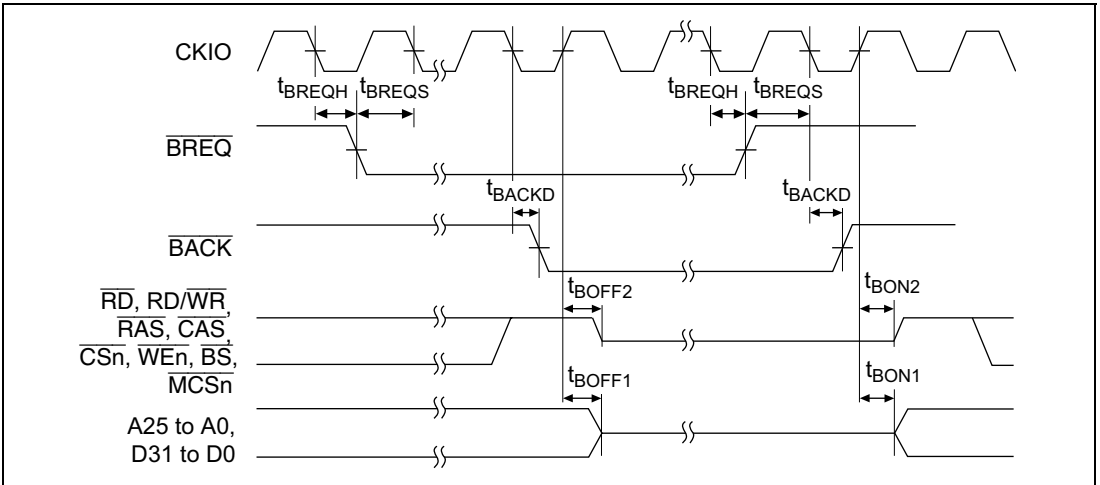

Figure 23.14 Bus Release Timing

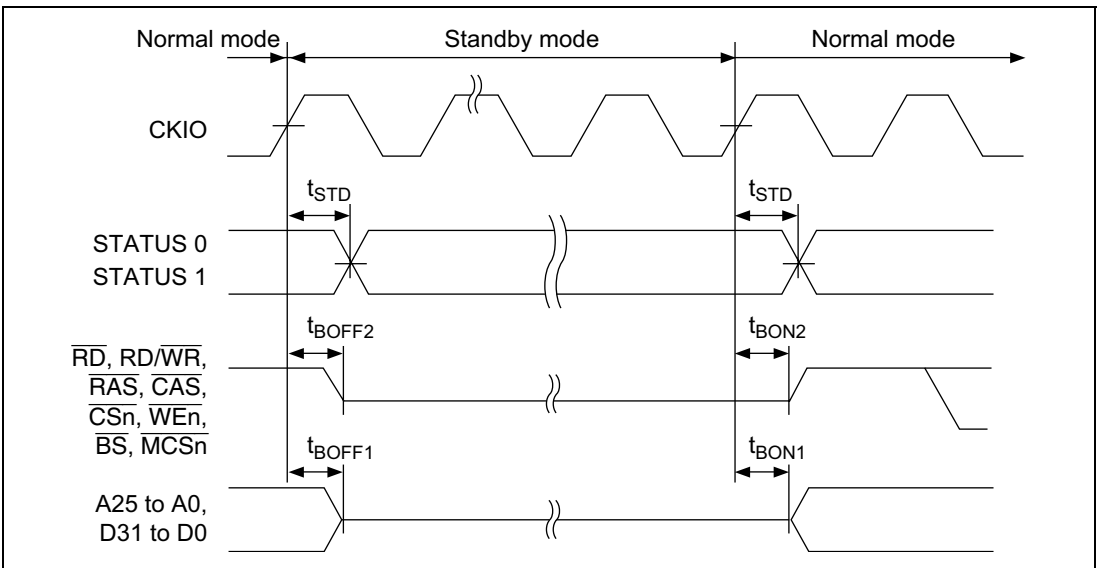

Figure 23.15 Pin Drive Timing at Standby

23.3.3 AC Bus Timing

Table 23.7 Bus Timing

Clock Modes 0/1/2/7, $V_{CCQ} = 3.3 \pm 0.3$ V, $V_{CC} = 1.55$ to 2.15 V, $AV_{CC} = 3.3 \pm 0.3$ V,
 $T_a = -20$ to 75°C

Item	Symbol	Min	Max	Unit	Figure
Address delay time	t_{AD}	1.5	12	ns	23.16–23.36, 23.39–23.46
Address setup time	t_{AS}	0	—	ns	23.16–23.18
Address hold time* ¹	t_{AH}	4	—	ns	23.16–23.21
\overline{BS} delay time	t_{BSD}	—	10	ns	23.16–23.36, 23.40–23.46
\overline{CS} delay time 1	t_{CSD1}	0	10	ns	23.16–23.21, 23.40–23.46
\overline{CS} delay time 2	t_{CSD2}	—	10	ns	23.16–23.21
\overline{CS} delay time (SDRAM access)	t_{CSD3}	1.5	10	ns	23.22–23.39
Read/write delay time	t_{RWD}	1.5	10	ns	23.16–23.46, 23.39–23.46
Read/write hold time	t_{RWH}	0	—	ns	23.16–23.21
Read strobe delay time	t_{RSD}	—	10	ns	23.16–23.21 23.40–23.43
Read data setup time 1	t_{RDS1}	6	—	ns	23.16–23.21, 23.40–23.46
Read data setup time 2	t_{RDS2}	5	—	ns	23.22–23.25, 23.30–23.33
Read data hold time 1* ²	t_{RDH1}	0	—	ns	23.16–23.21, 23.40–23.46
Read data hold time 2	t_{RDH2}	1	—	ns	23.22–23.25, 23.30–23.33
Write enable delay time	t_{WED}	—	10	ns	23.16–23.18, 23.40, 23.41
Write data delay time 1	t_{WDD1}	—	14	ns	23.16–23.18, 23.40, 23.41, 23.44–23.46
Write data delay time 2	t_{WDD2}	1.5	12	ns	23.26–23.29, 23.34–23.36
Write data hold time 1	t_{WDH1}	1.5	—	ns	23.16–23.18, 23.40, 23.41, 23.44–23.46
Write data hold time 2	t_{WDH2}	1.5	—	ns	23.26–23.29, 23.34–23.36
Write data hold time 3	t_{WDH3}	2	—	ns	23.16–23.18
Write data hold time 4	t_{WDH4}	2	—	ns	23.40, 23.41, 23.44–23.46
\overline{WAIT} setup time	t_{WTS}	5	—	ns	23.17–23.21, 23.41, 23.43, 23.45, 23.46
\overline{WAIT} hold time	t_{WTH}	0	—	ns	23.17–23.21, 23.41, 23.43, 23.45, 23.46
\overline{RAS} delay time 2	t_{RASD2}	1.5	10	ns	23.22–23.39
\overline{CAS} delay time 2	t_{CASD2}	1.5	10	ns	23.22–23.39
DQM delay time	t_{DQMD}	1.5	10	ns	23.22–23.36
CKE delay time	t_{CKED}	1.5	10	ns	23.38

Item	Symbol	Min	Max	Unit	Figure
$\overline{\text{CIORD}}$ delay time	t_{ICRSD}	—	10	ns	23.44–23.46
$\overline{\text{CIOWR}}$ delay time	t_{ICWSD}	—	10	ns	23.44–23.46
$\overline{\text{OIS16}}$ setup time	t_{IO16S}	6	—	ns	23.45, 23.46
$\overline{\text{OIS16}}$ hold time	t_{IO16H}	4	—	ns	23.45, 23.46
$\overline{\text{DACK}}$ delay time 1 (Reference for CKIO rise)	t_{DAKD1}	—	10	ns	23.16–23.36, 23.39–23.46
$\overline{\text{DACK}}$ delay time 2 (Reference for CKIO fall)	t_{DAKD2}	—	10	ns	23.16–23.22

- Notes: 1. Specified based on the slowest negate timing for $\overline{\text{CSn}}$, $\overline{\text{RD}}$, or $\overline{\text{WEn}}$
2. Specified based on whichever negate timing is faster, $\overline{\text{CSn}}$ or $\overline{\text{RD}}$.

23.3.4 Basic Timing

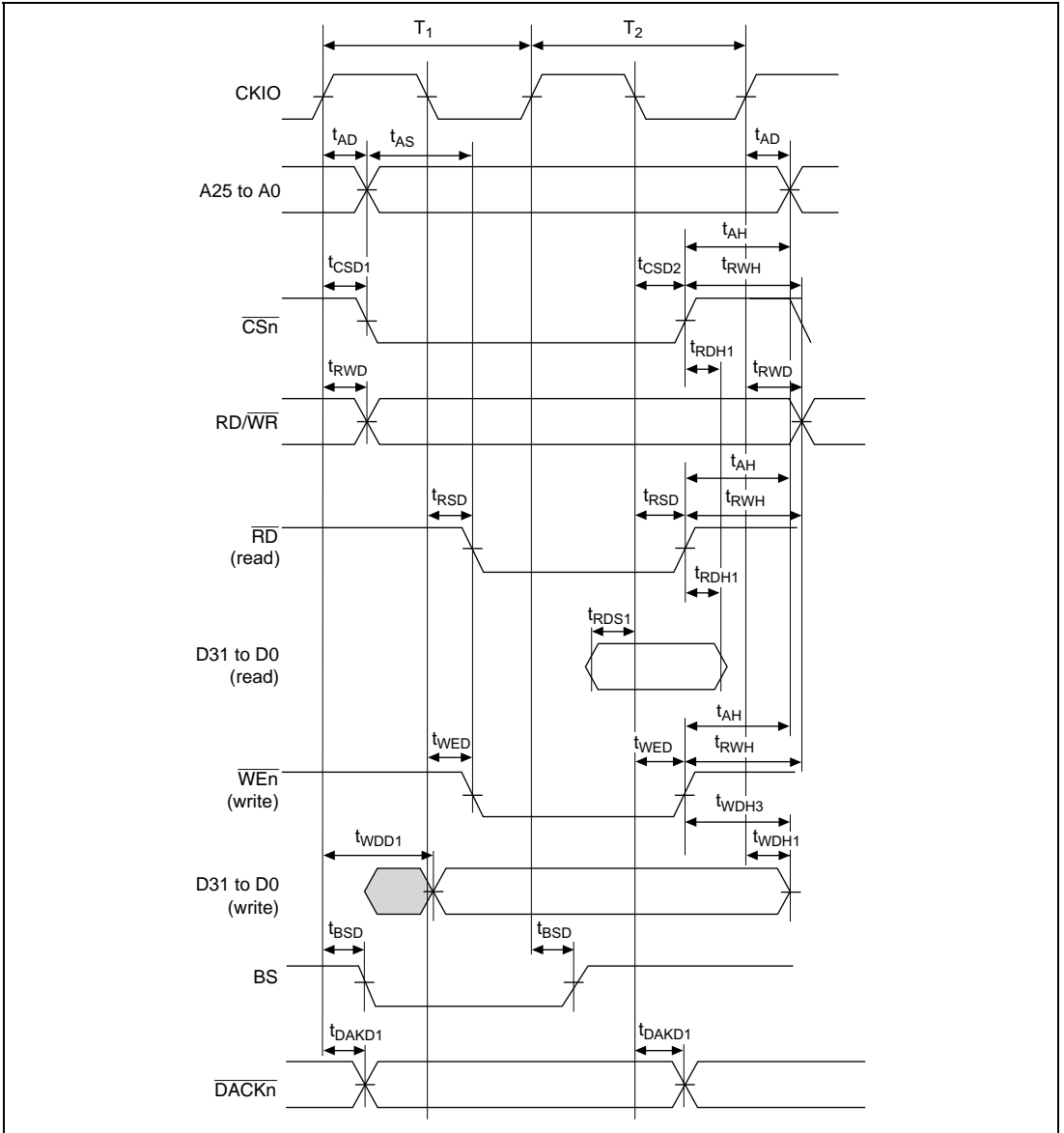

Figure 23.16 Basic Bus Cycle (No Wait)

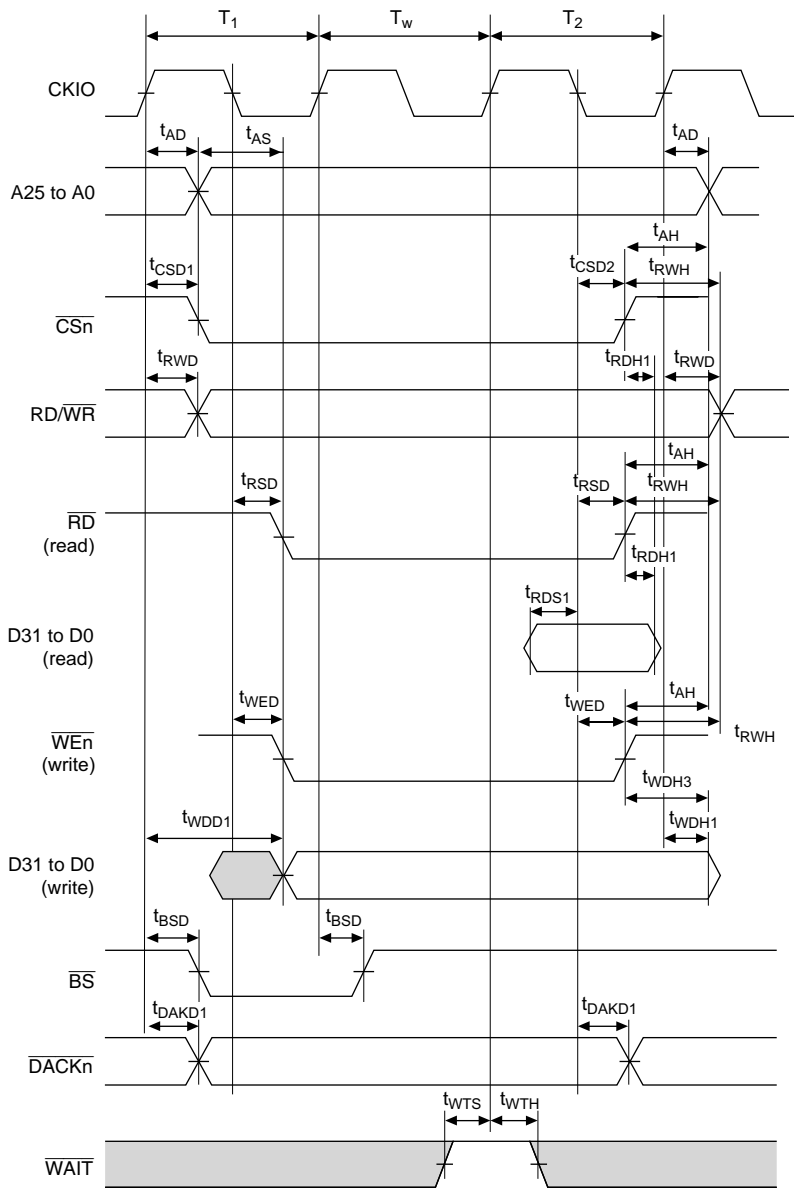

Figure 23.17 Basic Bus Cycle (One Wait)

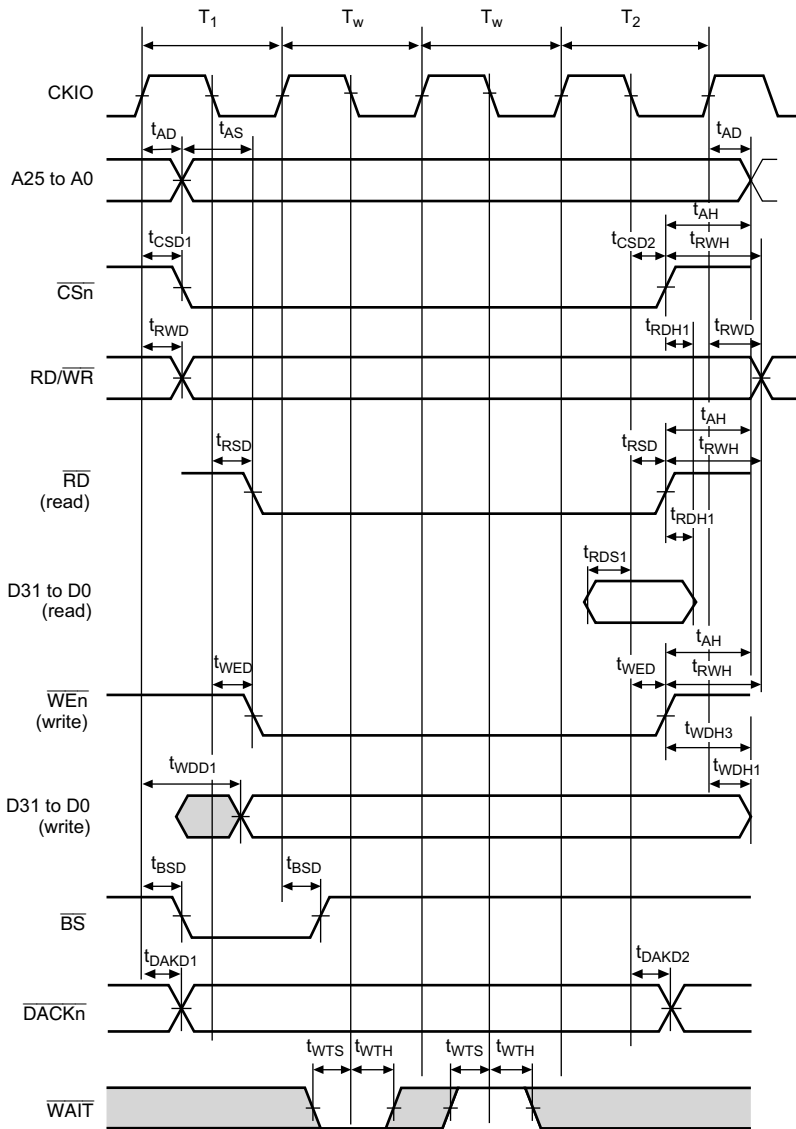
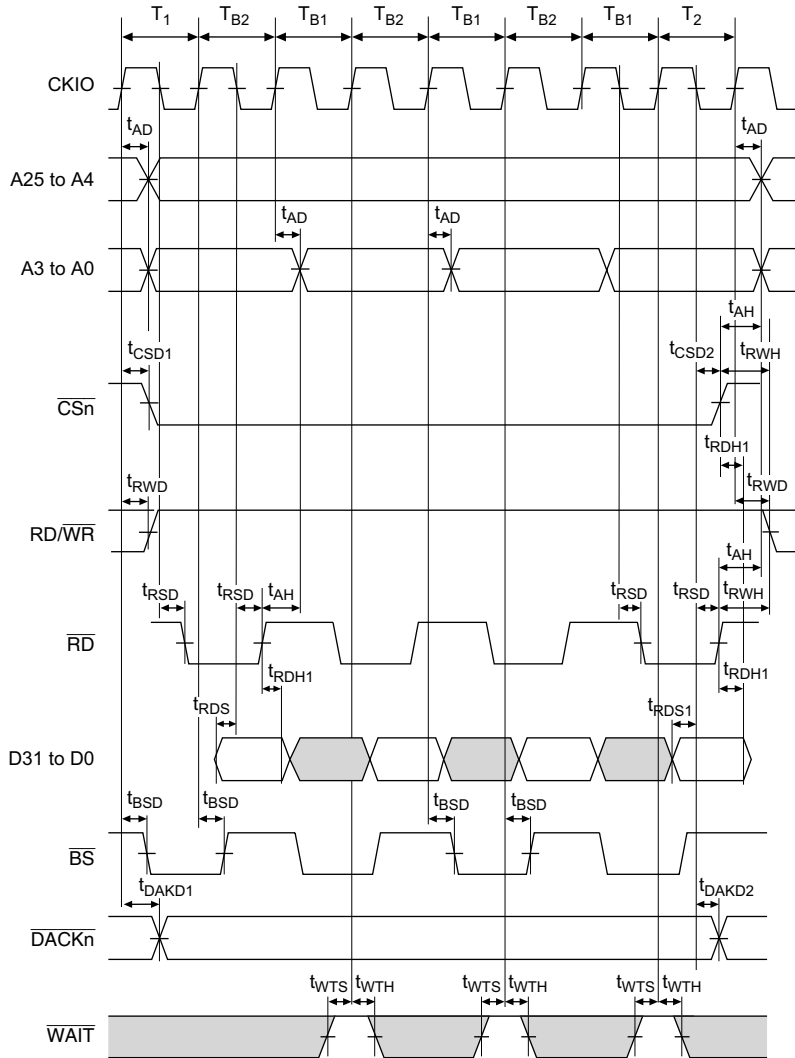

Figure 23.18 Basic Bus Cycle (External Wait, WAITSEL = 1)

23.3.5 Burst ROM Timing



Note: In the write cycle, the basic bus cycle, the basic bus cycle is performed.

Figure 23.19 Burst ROM Bus Cycle (No Wait)

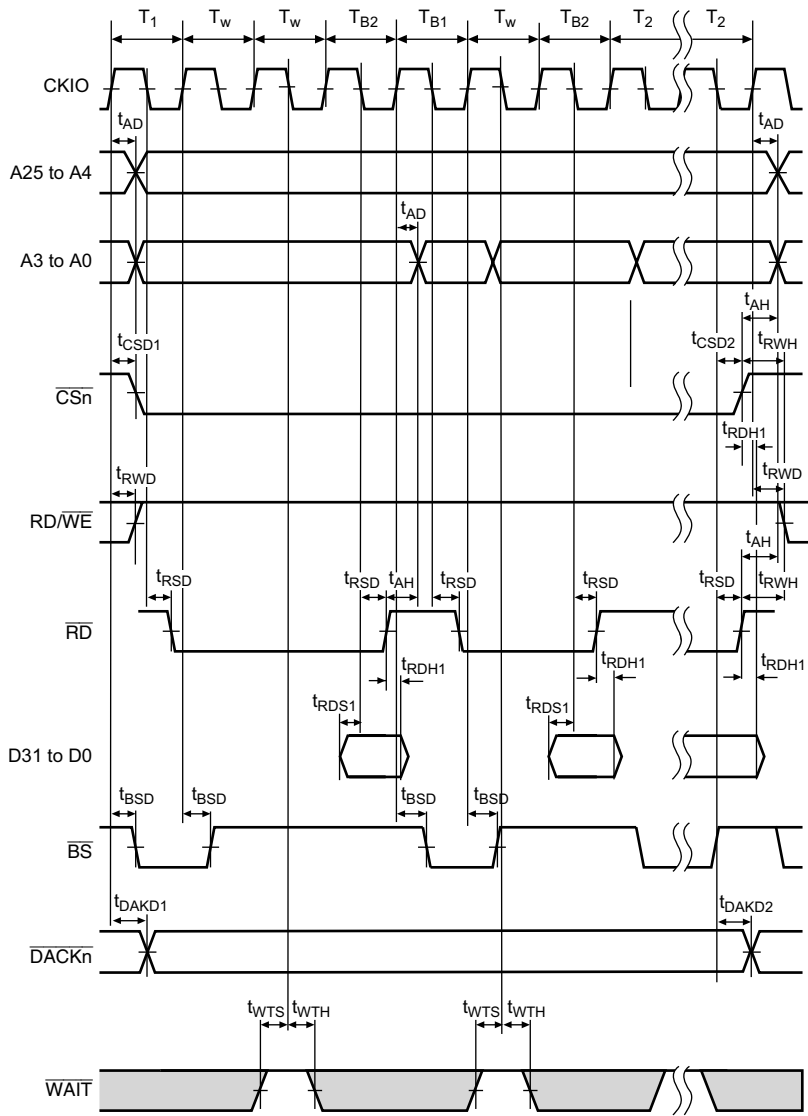

Note: In the write cycle, the basic bus cycle is performed.

Figure 23.20 Burst ROM Bus Cycle (Two Waits)

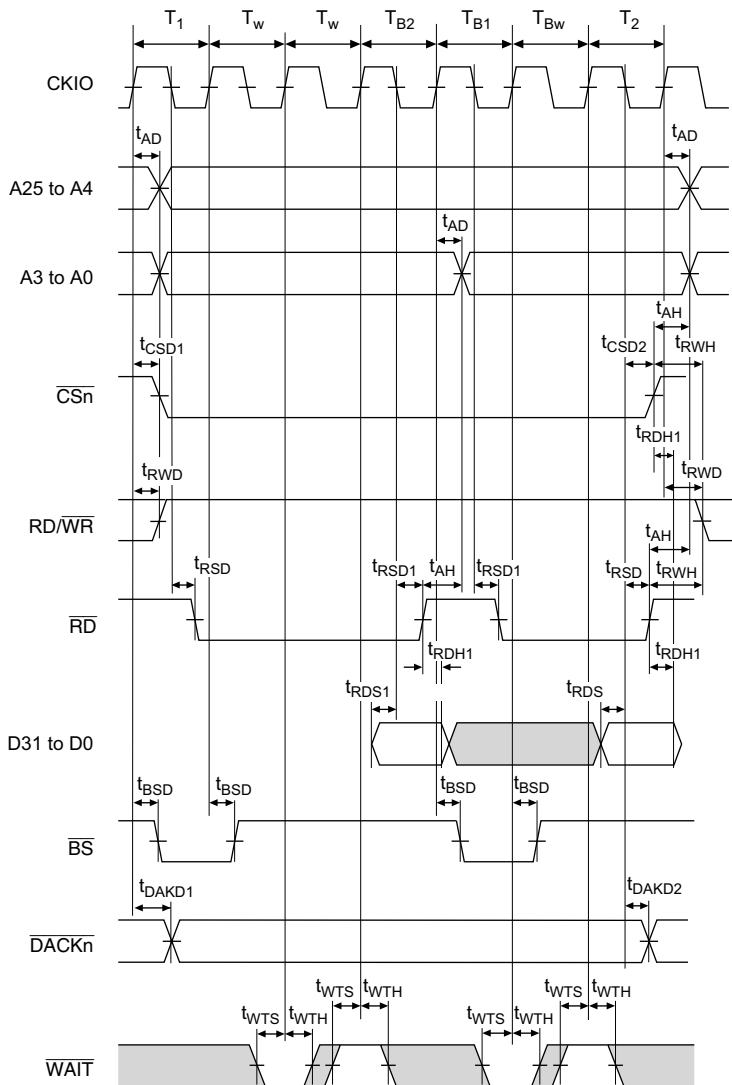

Note: In the write cycle, the basic bus cycle is performed.

Figure 23.21 Burst ROM Bus Cycle (External Wait, WAITSEL = 1)

23.3.6 Synchronous DRAM Timing

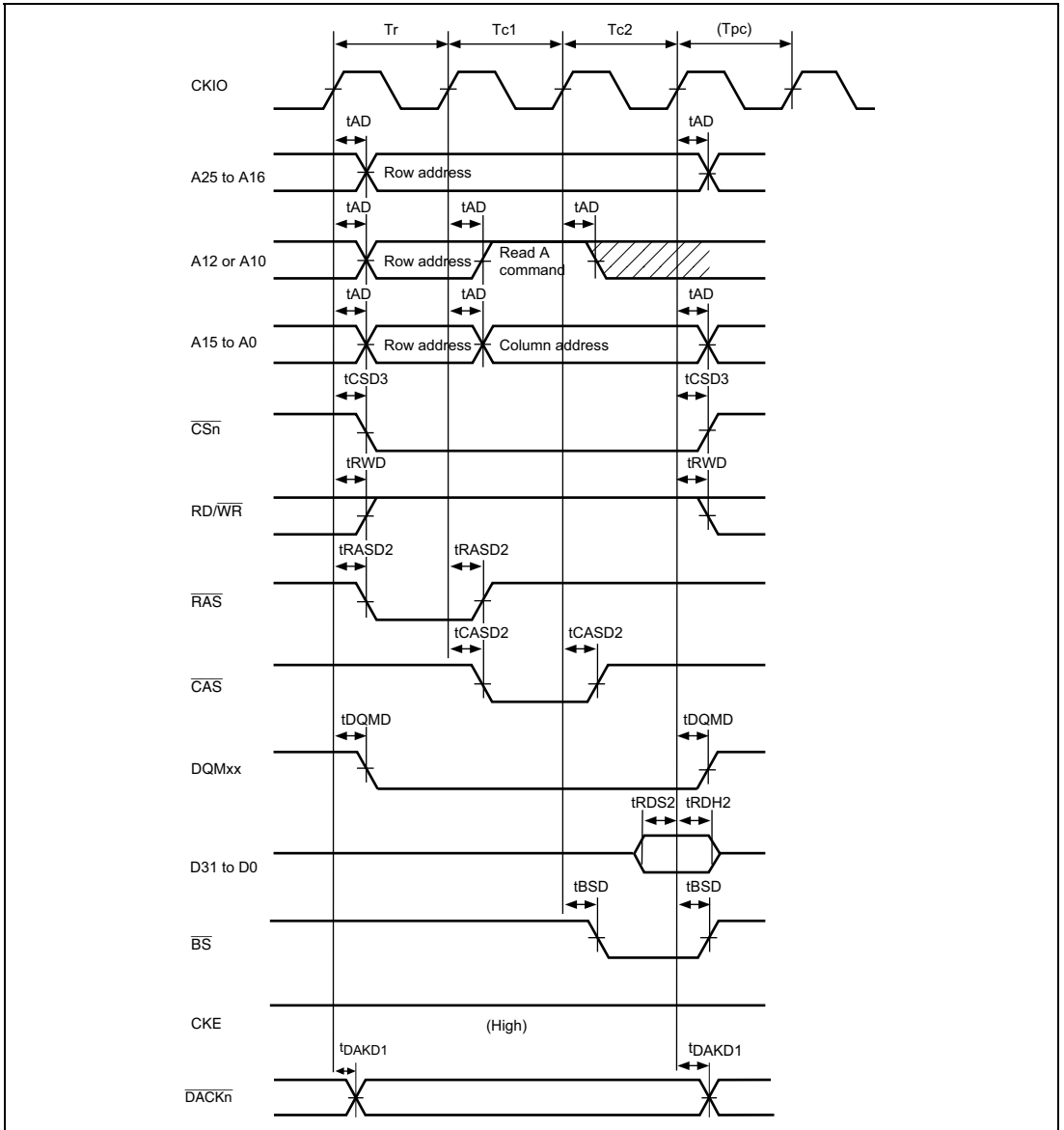

Figure 23.22 Synchronous DRAM Read Bus Cycle (RCD = 0, CAS Latency = 1, TPC = 0)

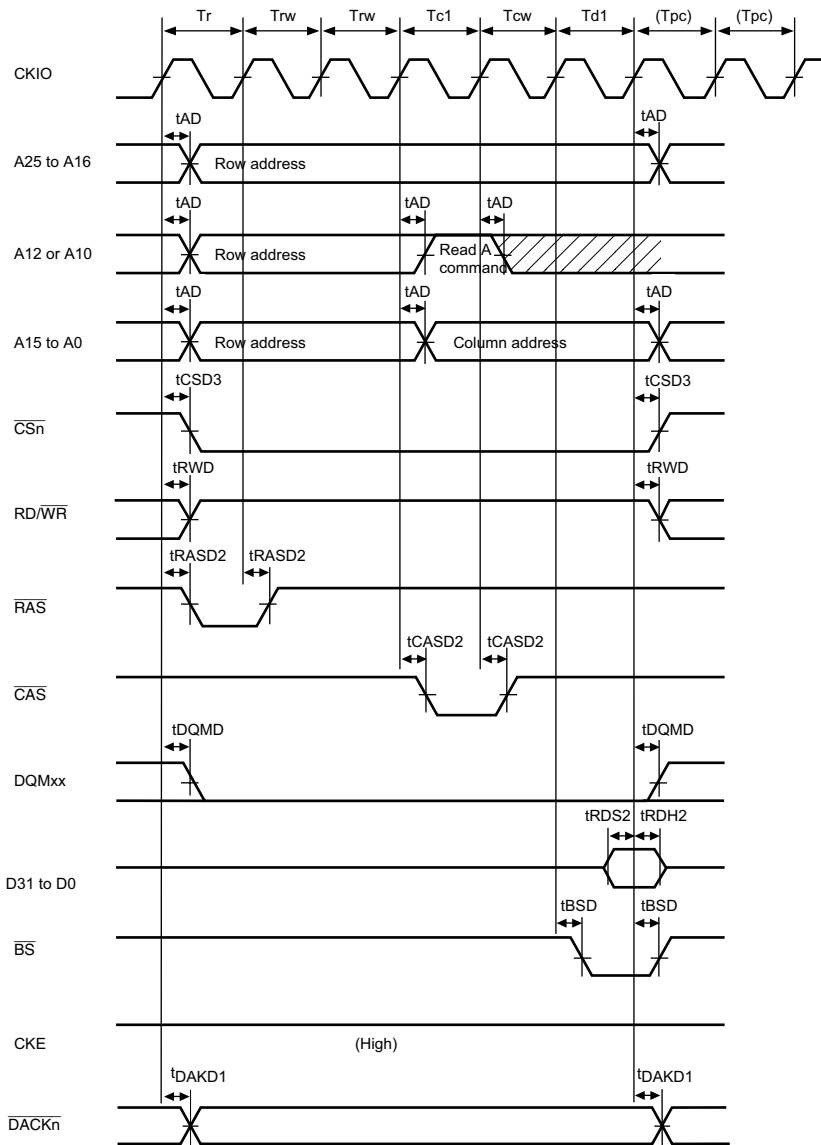

Figure 23.23 Synchronous DRAM Read Bus Cycle (RCD = 2, CAS Latency = 2, TPC = 1)

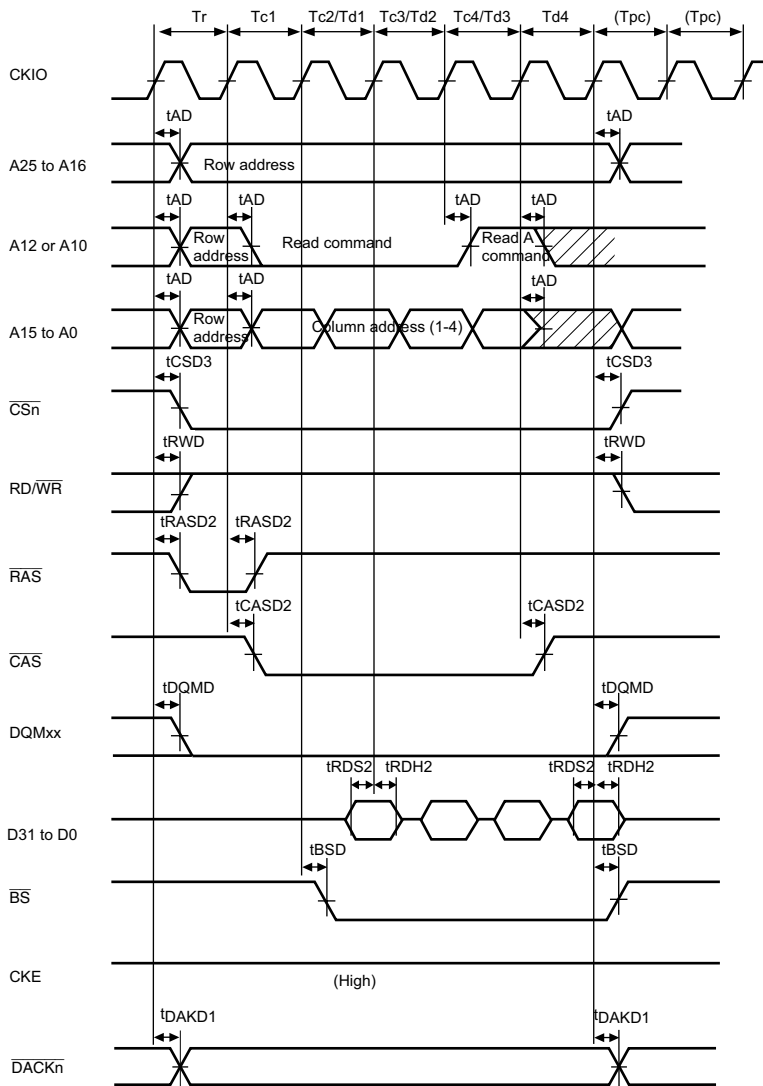

Figure 23.24 Synchronous DRAM Read Bus Cycle (Burst Read (Single Read × 4), RCD = 0, CAS Latency = 1, TPC = 1)

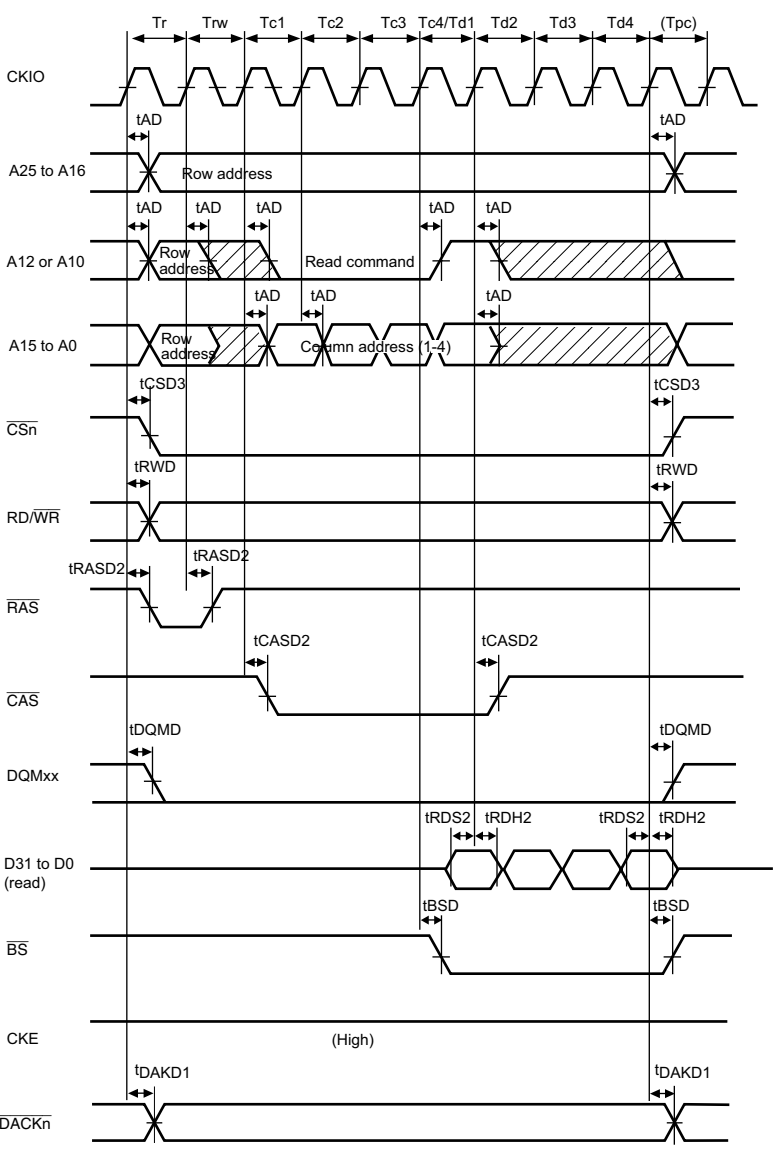

Figure 23.25 Synchronous DRAM Read Bus Cycle (Burst Read (Single Read × 4), RCD = 1, CAS Latency = 3, TPC = 0)

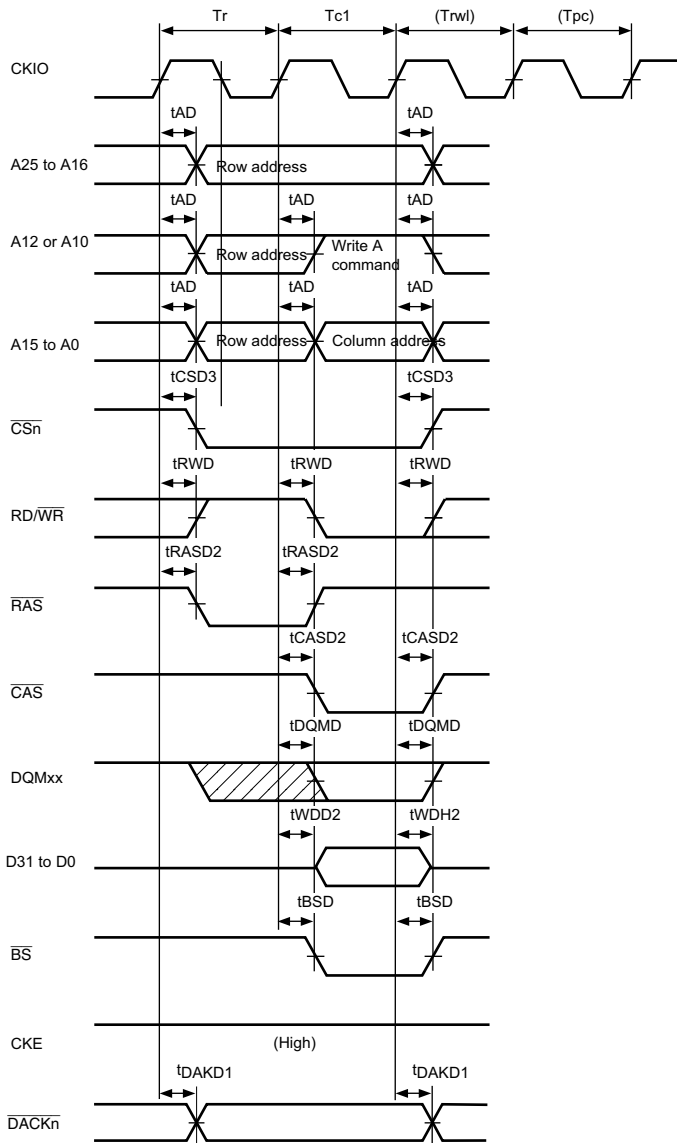

Figure 23.26 Synchronous DRAM Write Bus Cycle (RCD = 0, TPC = 0, TRWL = 0)

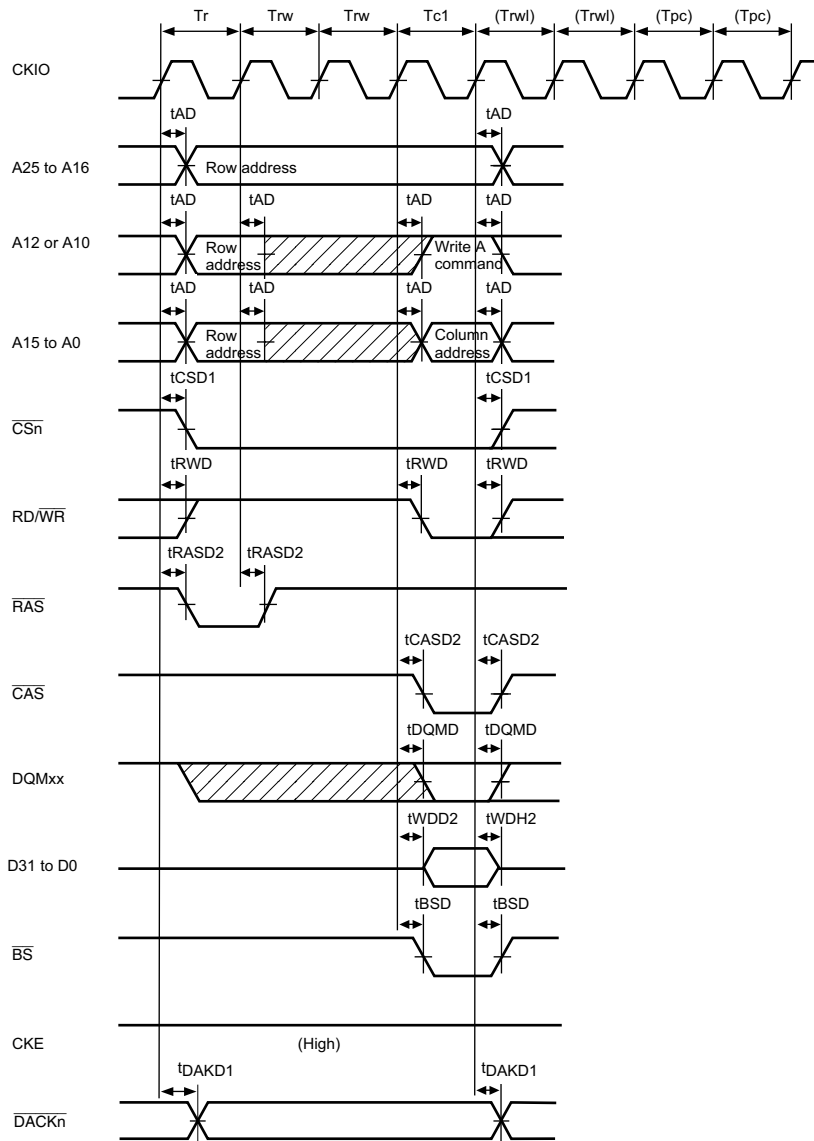

Figure 23.27 Synchronous DRAM Write Bus Cycle (RCD = 2, TPC = 1, TRWL = 1)

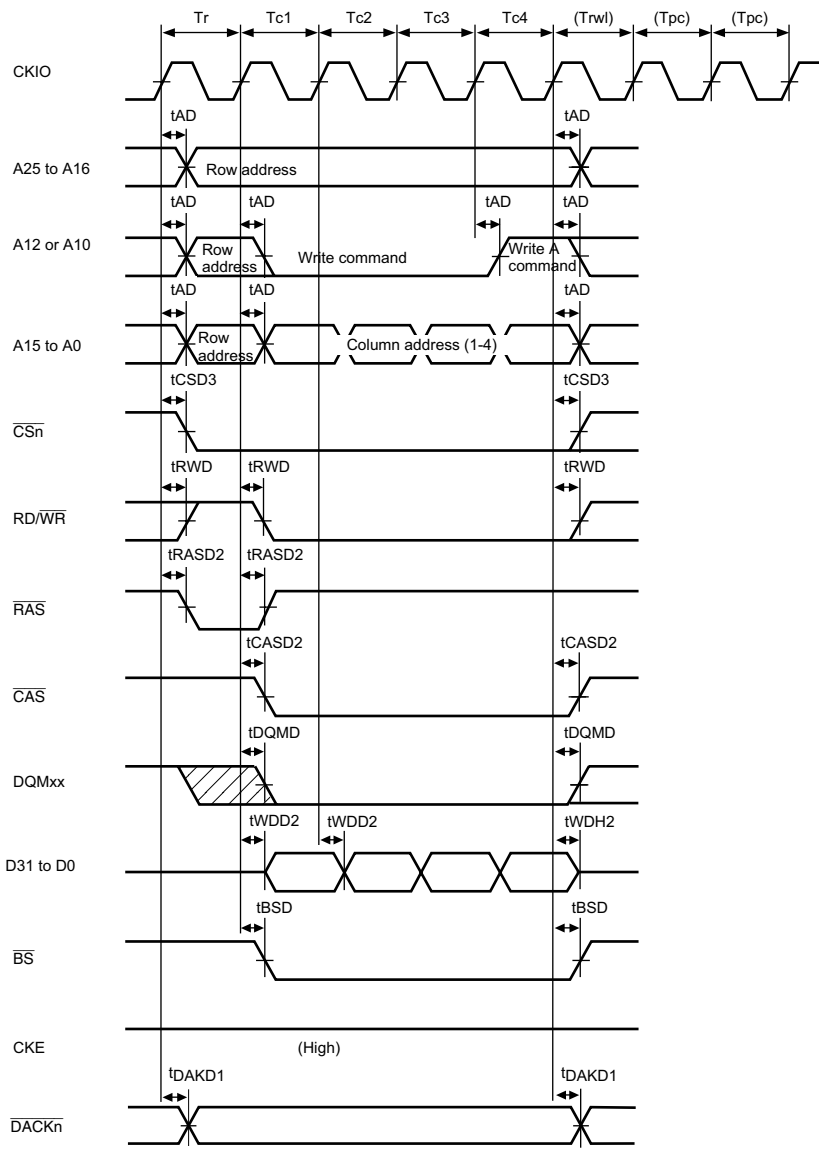

Figure 23.28 Synchronous DRAM Write Bus Cycle (Burst Mode (Single Write × 4), RCD = 0, TPC = 1, TRWL = 0)

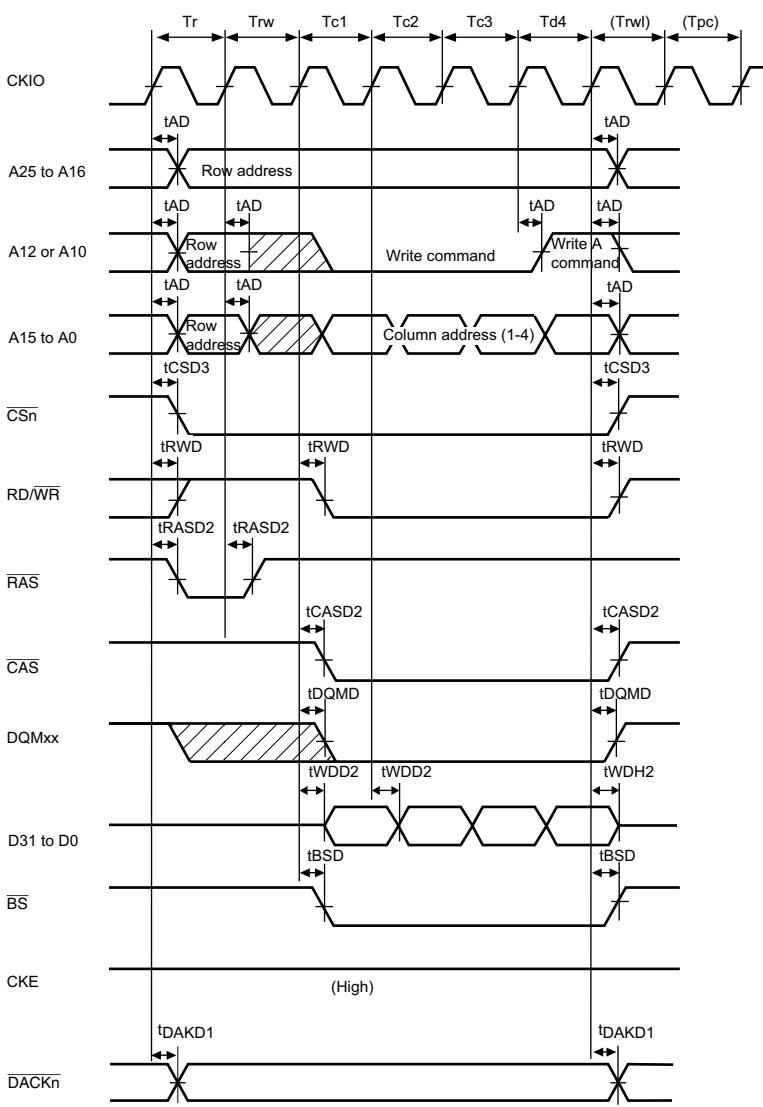
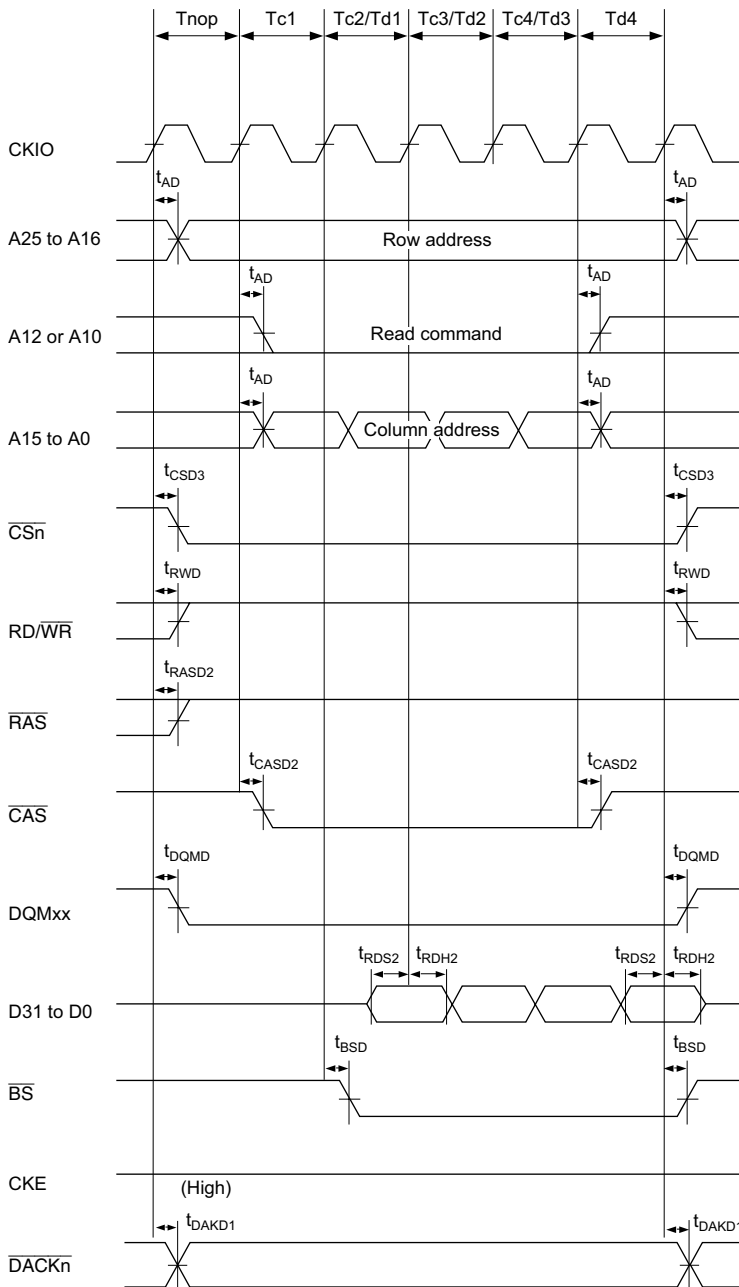
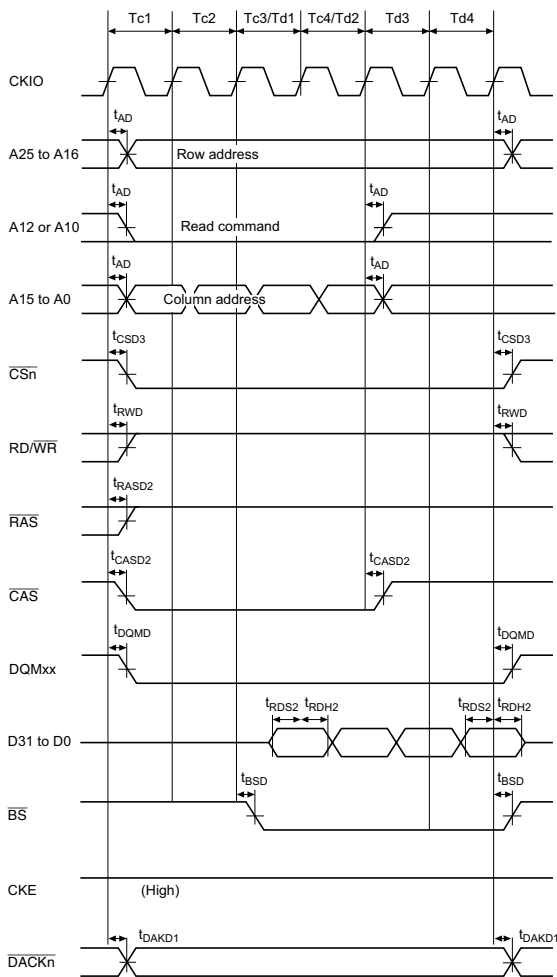

Figure 23.29 Synchronous DRAM Write Bus Cycle (Burst Mode (Single Write × 4), RCD = 1, TPC = 0, TRWL = 0)



**Figure 23.30 Synchronous DRAM Burst Read Bus Cycle
(RAS Down, Same Row Address, CAS Latency = 1)**



**Figure 23.31 Synchronous DRAM Burst Read Bus Cycle
(RAS Down, Same Row Address, CAS Latency = 2)**

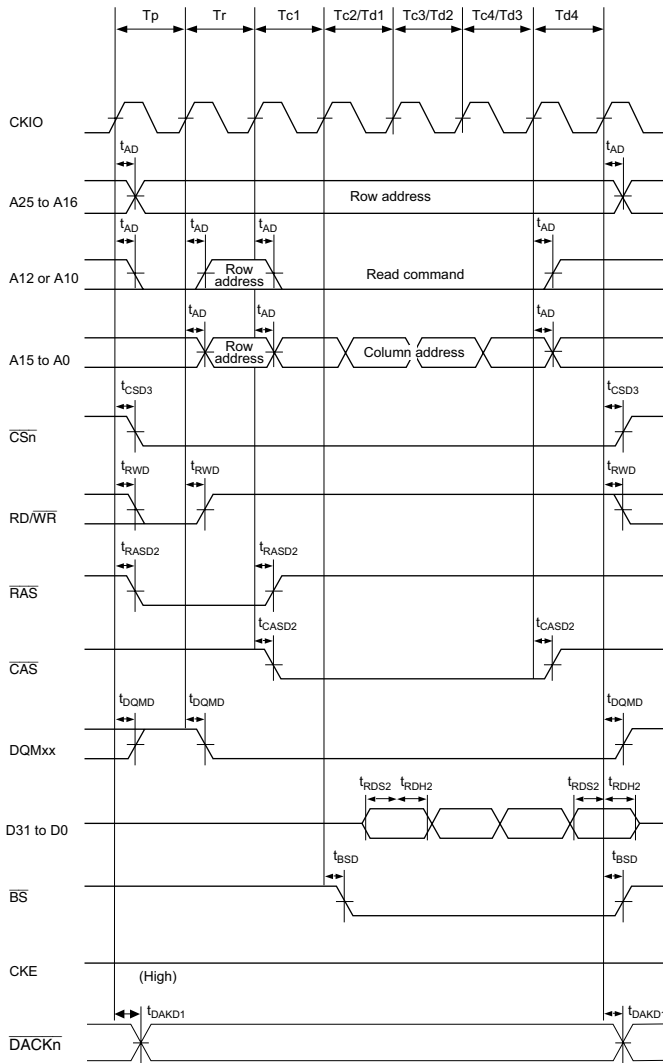

**Figure 23.32 Synchronous DRAM Burst Read Bus Cycle
(RAS Down, Different Row Address, TPC = 0, RCD = 0, CAS Latency = 1)**

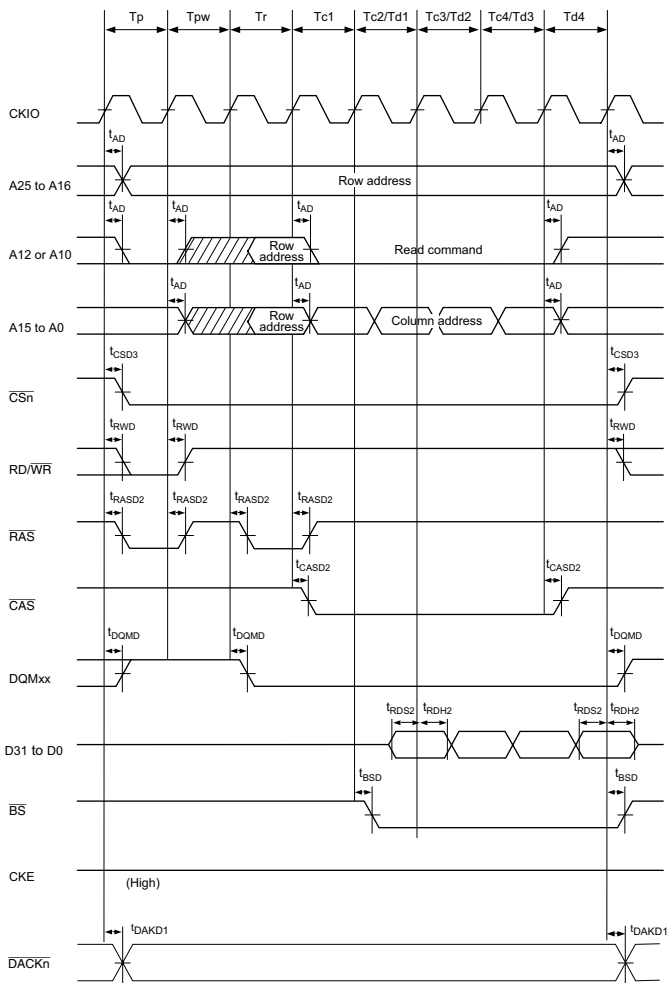

**Figure 23.33 Synchronous DRAM Burst Read Bus Cycle
(RAS Down, Different Row Address, TPC = 1, RCD = 0, CAS Latency = 1)**

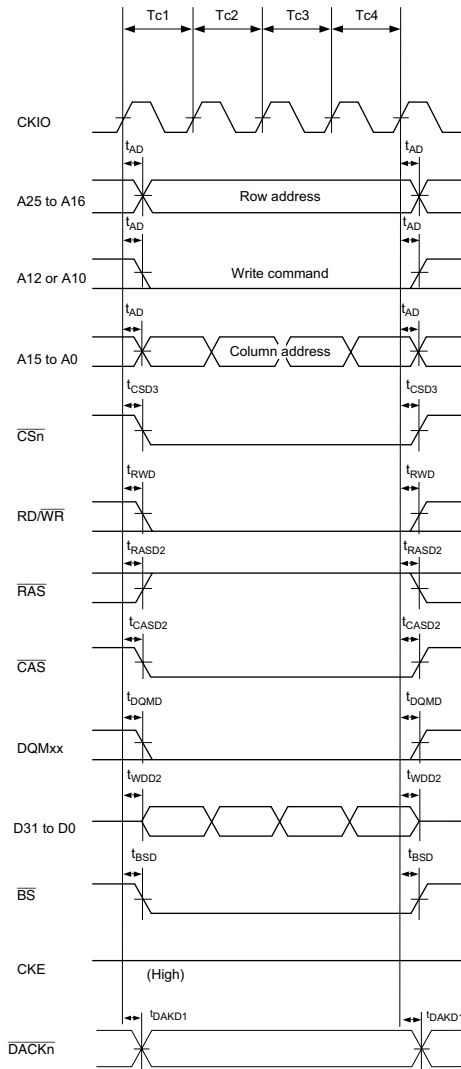

Figure 23.34 Synchronous DRAM Burst Write Bus Cycle (RAS Down, Same Row Address)

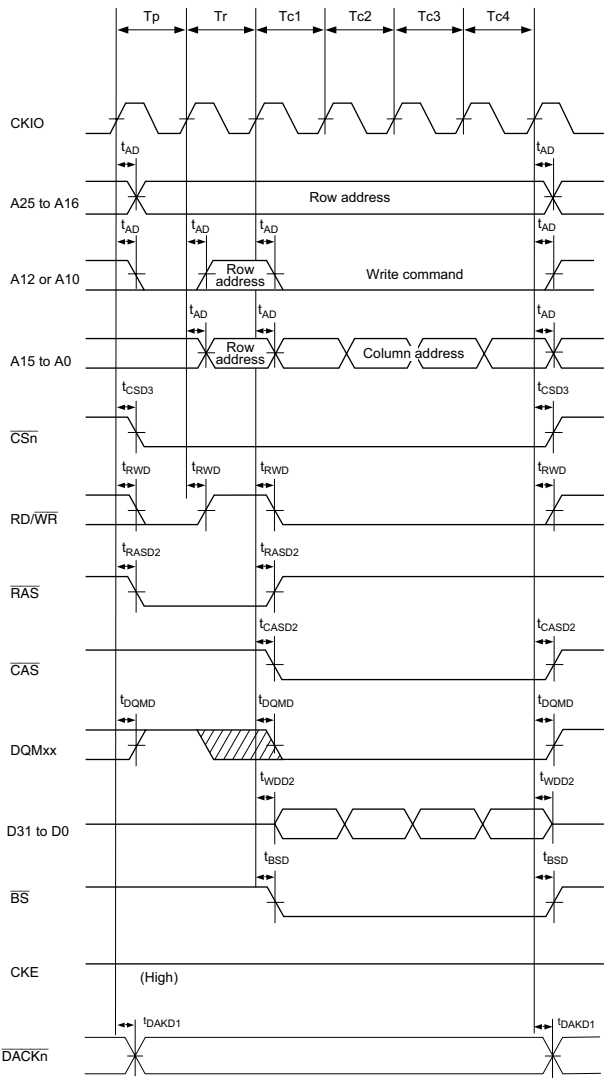

Figure 23.35 Synchronous DRAM Burst Write Bus Cycle (RAS Down, Different Row Address, TPC = 0, RCD = 0)

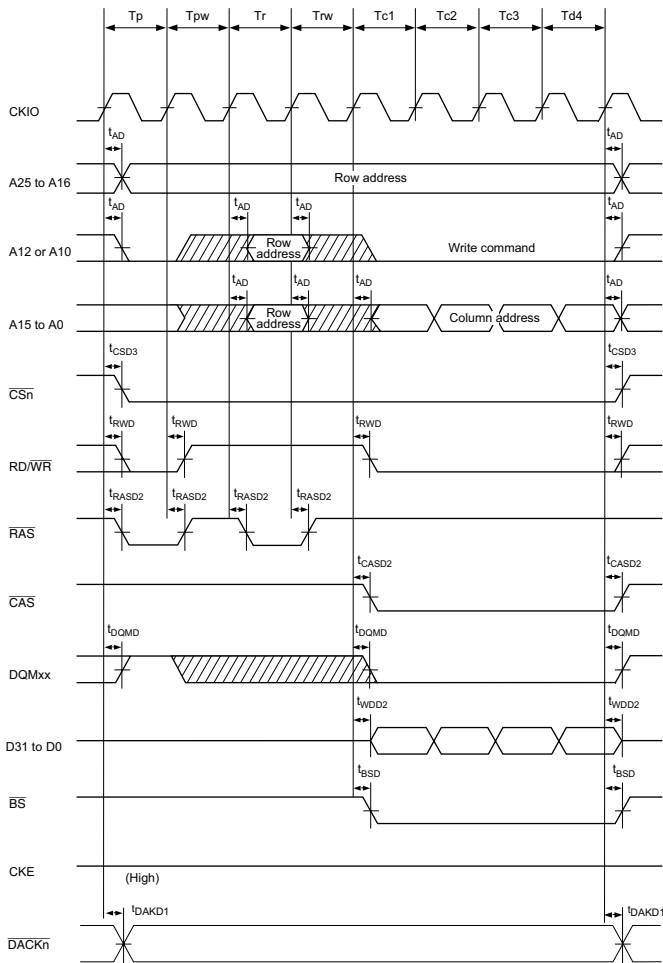

Figure 23.36 Synchronous DRAM Burst Write Bus Cycle (RAS Down, Different Row Address, TPC = 1, RCD = 1)

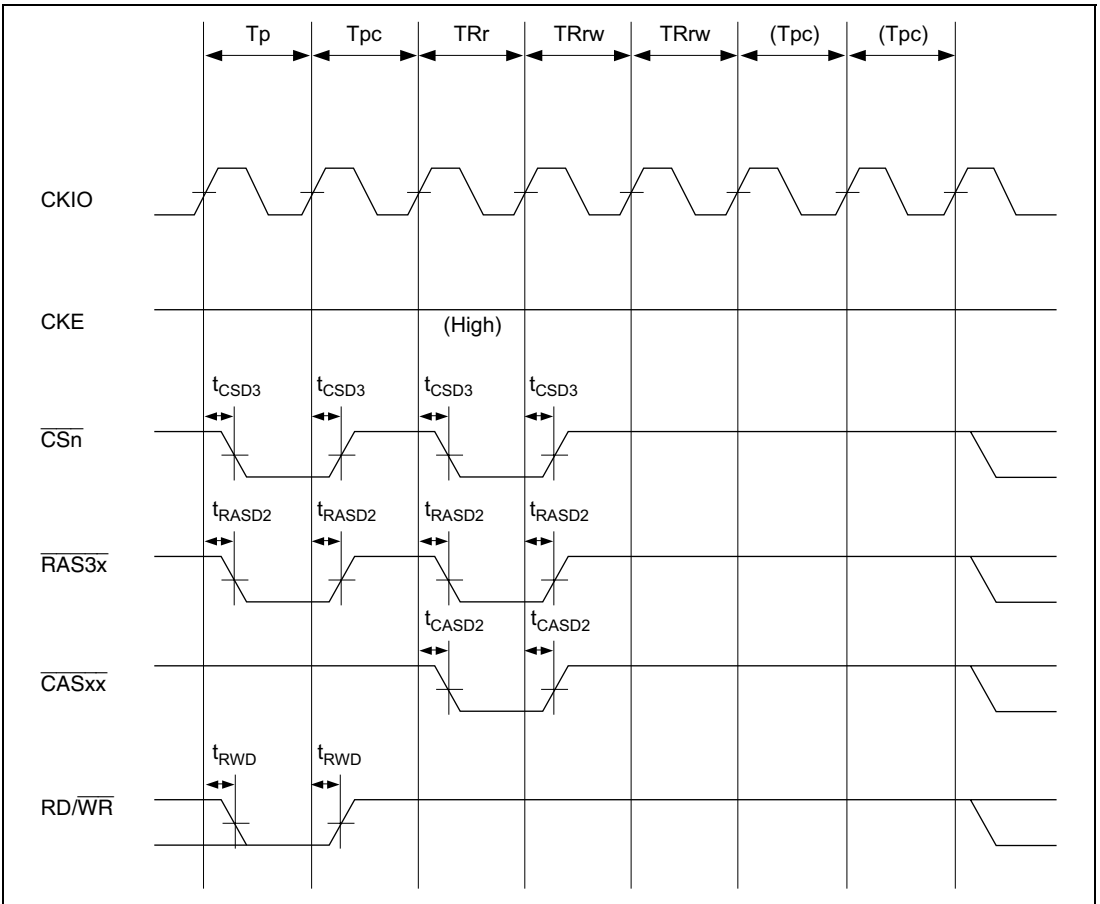

Figure 23.37 Synchronous DRAM Auto-Refresh Timing (TRAS = 1, TPC = 1)

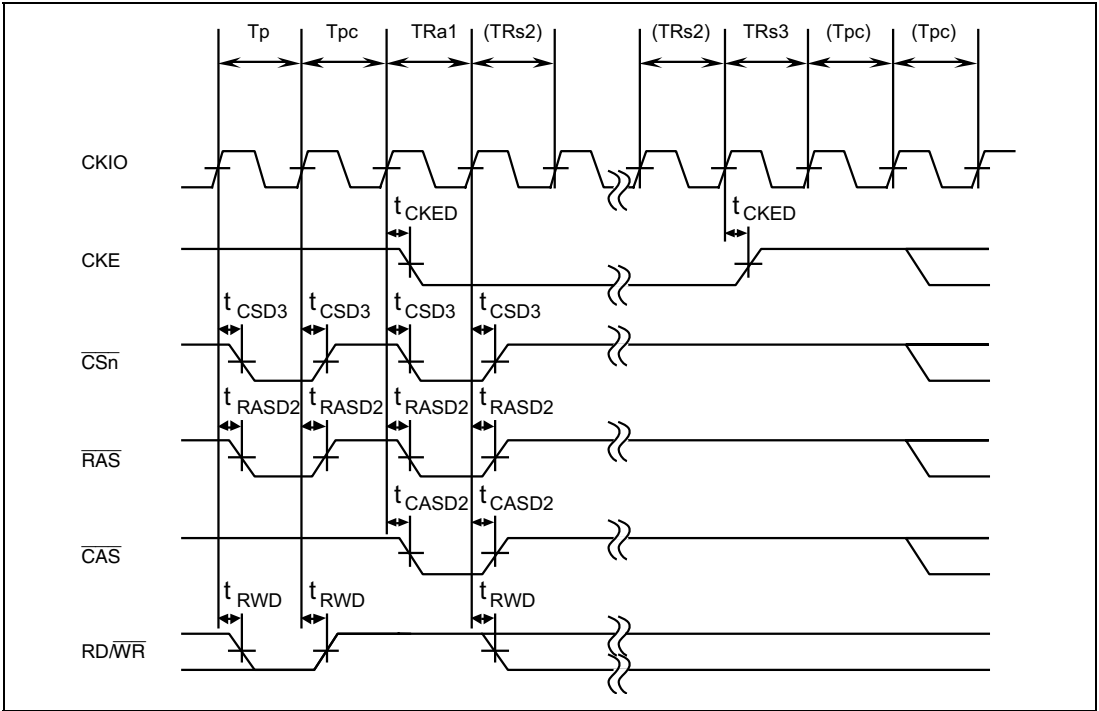

Figure 23.38 Synchronous DRAM Self-Refresh Cycle (TRAS = 1, TPC = 1)

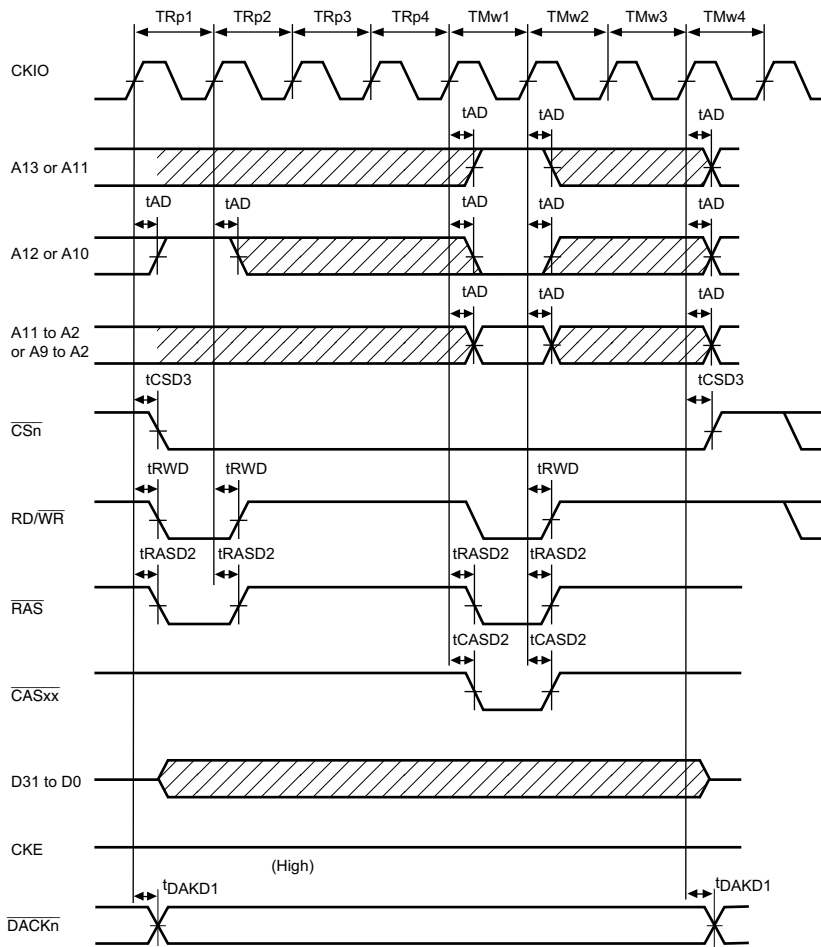

Figure 23.39 Synchronous DRAM Mode Register Write Cycle

23.3.7 PCMCIA Timing

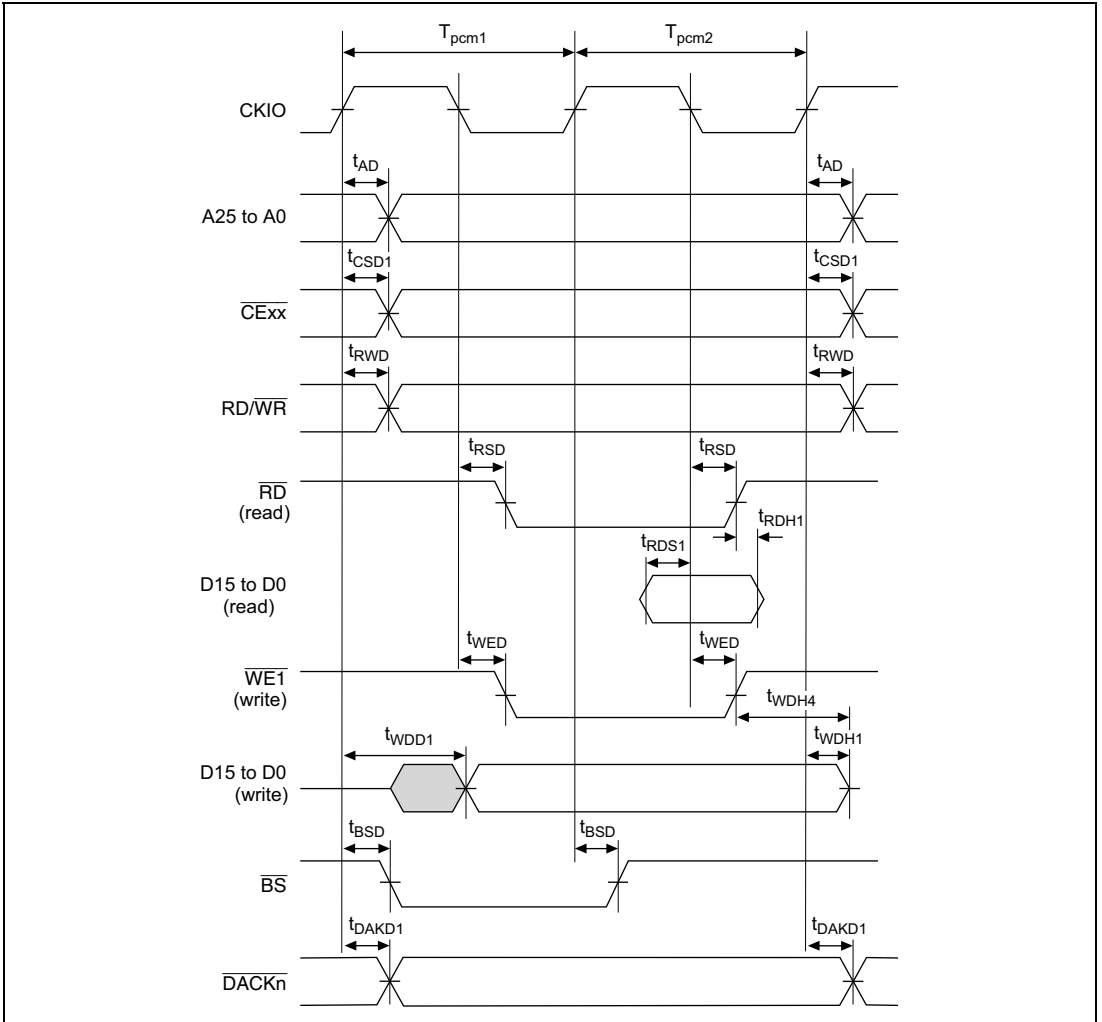

Figure 23.40 PCMCIA Memory Bus Cycle ($TED = 0$, $TEH = 0$, No Wait)

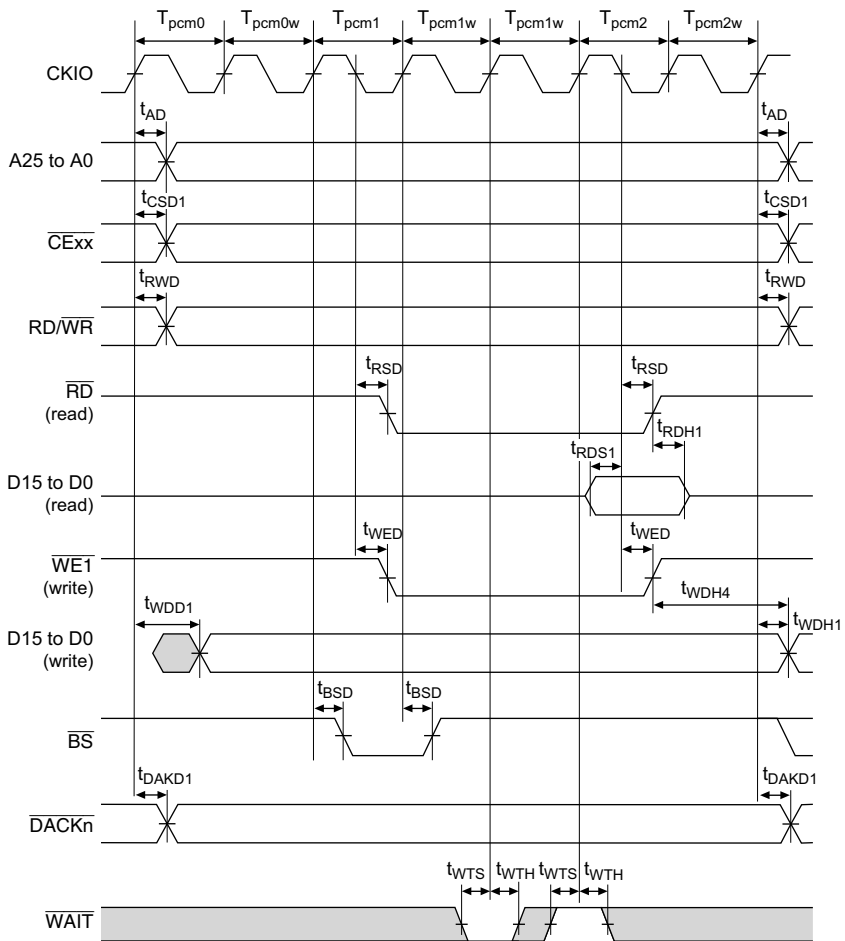
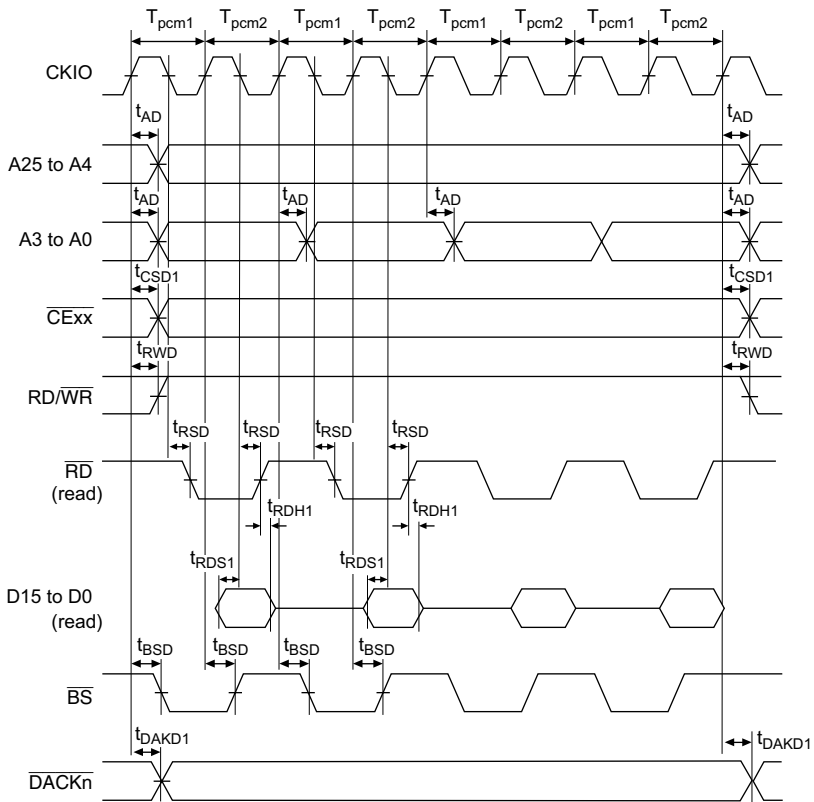
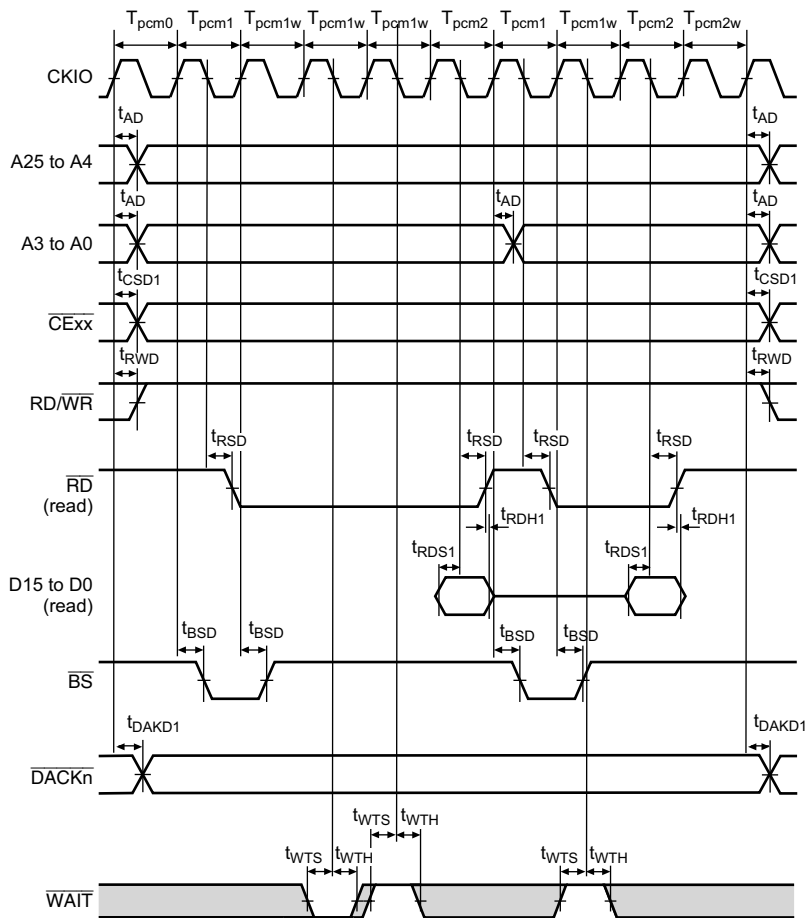

Figure 23.41 PCMCIA Memory Bus Cycle
(TED = 2, TEH = 1, One Wait, External Wait, WAITSEL = 1)



Note: Even though burst mode is set, write cycle operation is the same as in normal mode.

**Figure 23.42 PCMCIA Memory Bus Cycle
(Burst Read, TED = 0, TEH = 0, No Wait)**



Note: Even though burst mode is set, the write cycle operation is the same as in normal mode.

Figure 23.43 PCMCIA Memory Bus Cycle
(Burst Read, TED = 1, TEH = 1, Two Waits, Burst Pitch = 3, WAITSEL = 1)

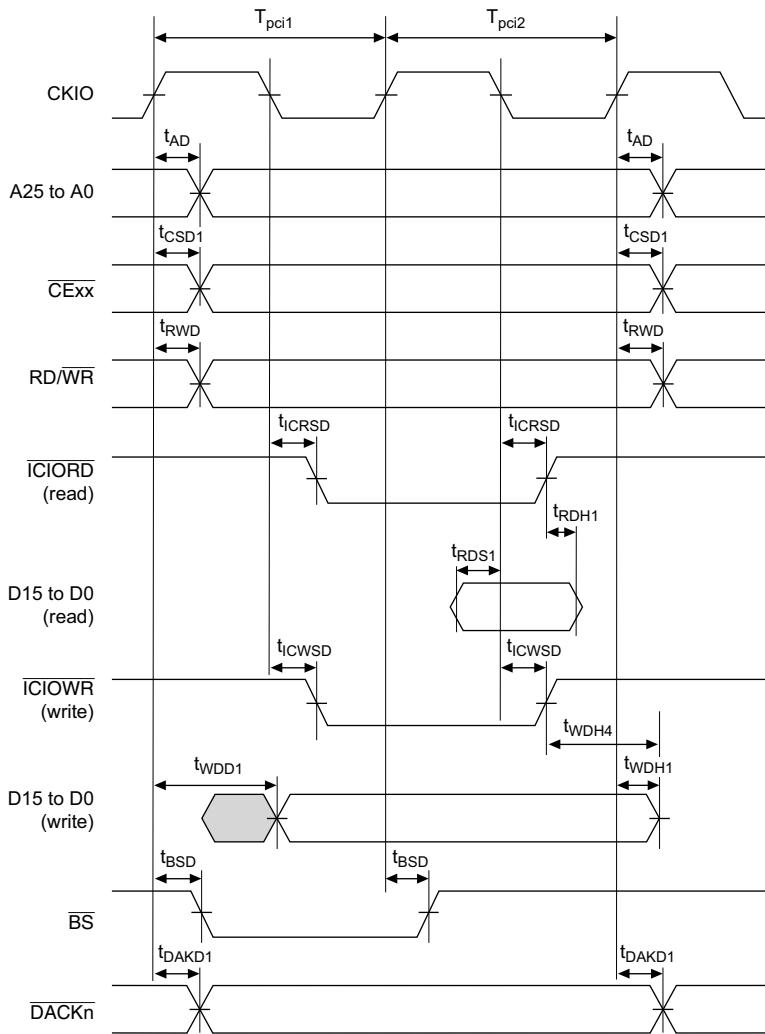

Figure 23.44 PCMCIA I/O Bus Cycle (TED = 0, TEH = 0, No Wait)

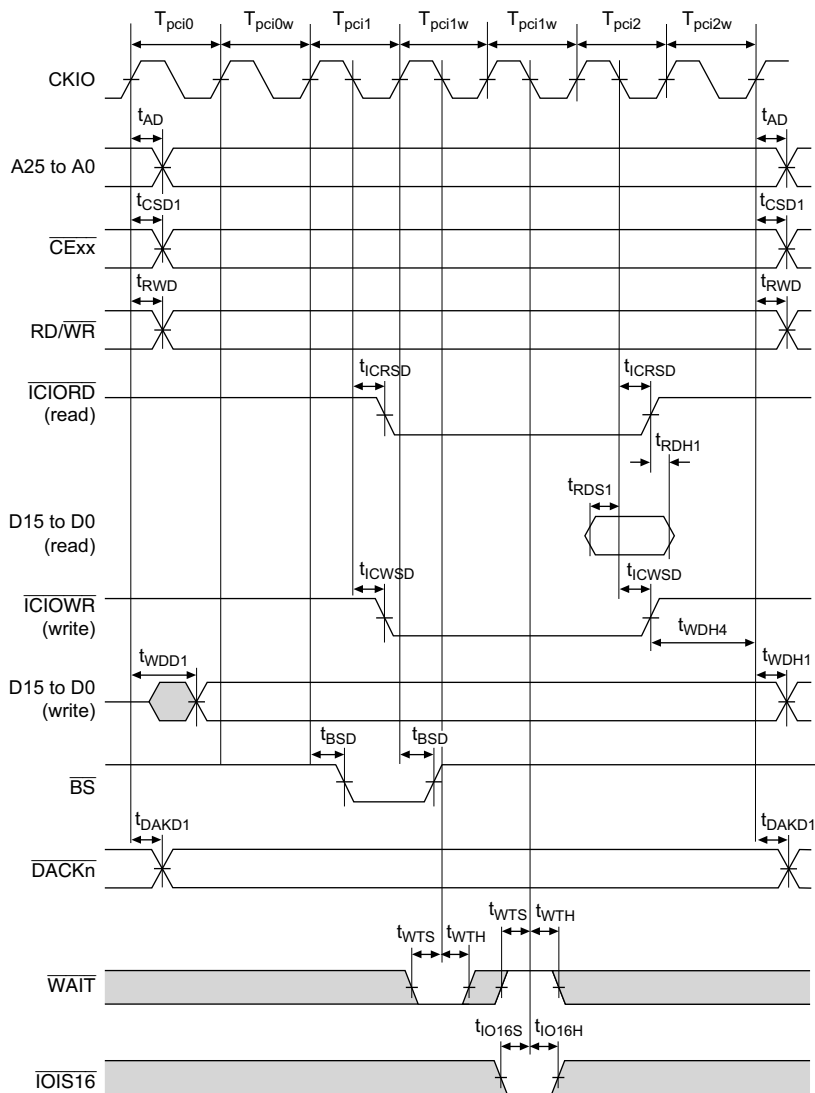

Figure 23.45 PCMCIA I/O Bus Cycle
(TED = 2, TEH = 1, One Wait, External Wait, WAITSEL = 1)

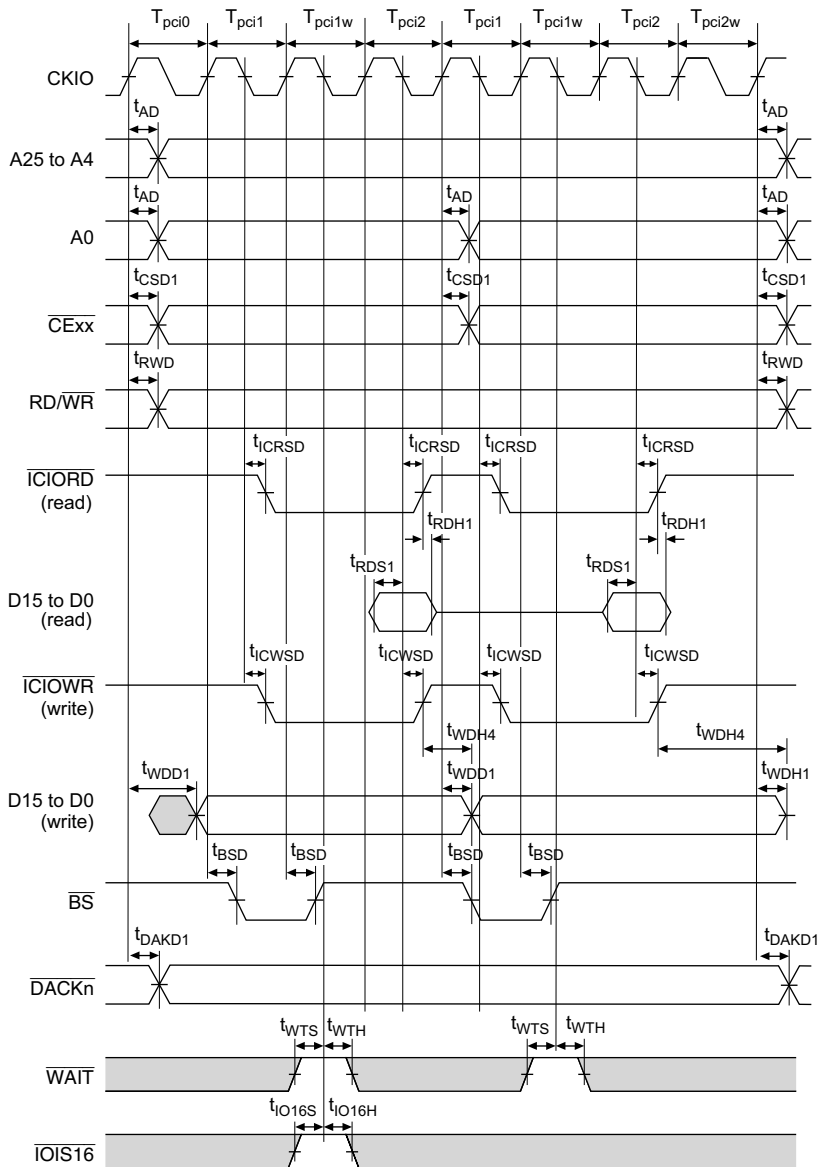

Figure 23.46 PCMCIA I/O Bus Cycle
(TED = 1, TEH = 1, One Wait, Bus Sizing, WAITSEL = 1)

23.3.8 Peripheral Module Signal Timing

Table 23.8 Peripheral Module Signal Timing

$V_{ccQ} = 3.3 \pm 0.3$ V, $V_{cc} = 1.55$ to 2.15 V, $AV_{cc} = 3.3 \pm 0.3$ V, $T_a = -20$ to 75°C

Module	Item	Symbol	Min	Max	Unit	Figure	
TMU, RTC	Timer input setup time	t_{TCLKS}	15	—	ns	23.47	
	Timer clock input setup time	t_{TCKS}	15	—		23.48	
	Timer clock pulse width	Edge specification	t_{TCKWH}	1.5	—	Pcyc	
		Both edge specification	t_{TCKWL}	2.5	—		
	Oscillation settling time	t_{ROSC}	3	—	s	23.49	
SCI	Input clock cycle	Asynchronization	t_{SCYC}	4	—	Pcyc*	23.50
		Clock synchronization		6	—		23.51
	Input clock rise time	t_{SCKR}	—	1.5		23.50	
	Input clock fall time	t_{SCKF}	—	1.5			
	Input clock pulse width	t_{SCKW}	0.4	0.6	tscyc		
	Transmission data delay time	t_{TXD}	—	100	ns	23.51	
	Receive data setup time (clock synchronization)	t_{RXS}	100	—			
	Receive data hold time (clock synchronization)	t_{RXH}	100	—			
	RTS delay time	t_{RTSD}	—	100			
	CTS setup time (clock synchronization)	t_{CTSS}	100	—			
	CTS hold time (clock synchronization)	t_{CTSH}	100	—			
Port	Output data delay time	t_{PORTD}	—	17	ns	23.52	
	Input data setup time	t_{PORTS1}	15	—			
	Input data hold time	t_{PORTH1}	8	—			
	Input data setup time	t_{PORTS2}	tcyc + 15	—			
	Input data hold time	t_{PORTH2}	8	—			
	Input data setup time	t_{PORTS3}	$3 \times \text{tcyc} + 15$	—			
	Input data hold time	t_{PORTH3}	8	—			
DMAC	DREQ setup time	t_{DRQS}	6	—	ns	23.53	
	DREQ hold time	t_{DREQH}	4	—			
	DRAK delay time	t_{DRAKD}	—	10		23.54	

Note: * Pcyc is the P clock cycle.

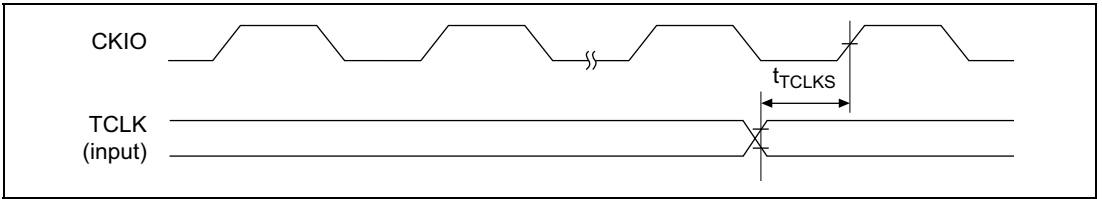

Figure 23.47 TCLK Input Timing

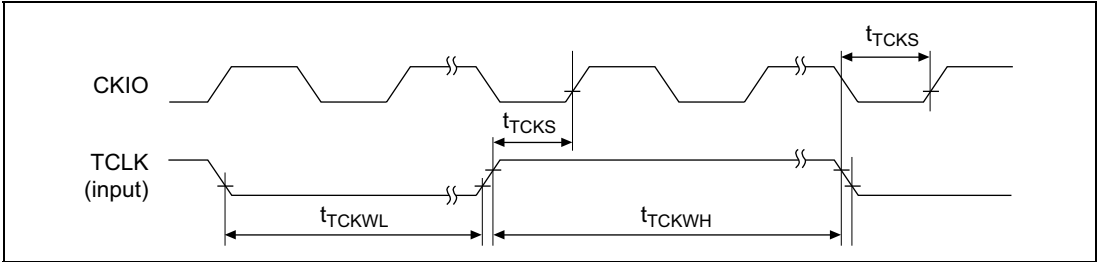

Figure 23.48 TCLK Clock Input Timing

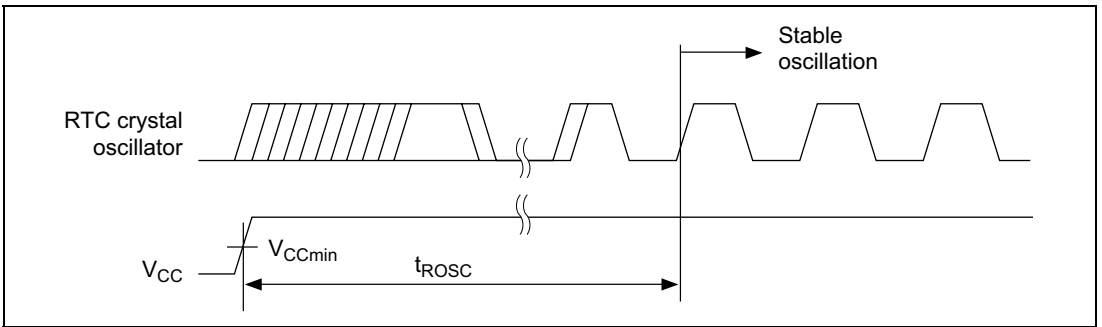

Figure 23.49 Oscillation Settling Time at RTC Crystal Oscillator Power-on

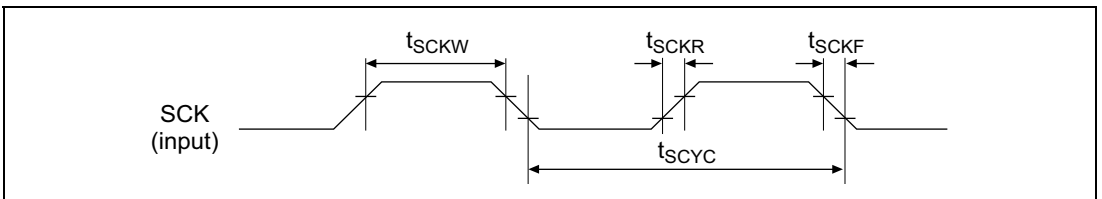

Figure 23.50 SCK Input Clock Timing

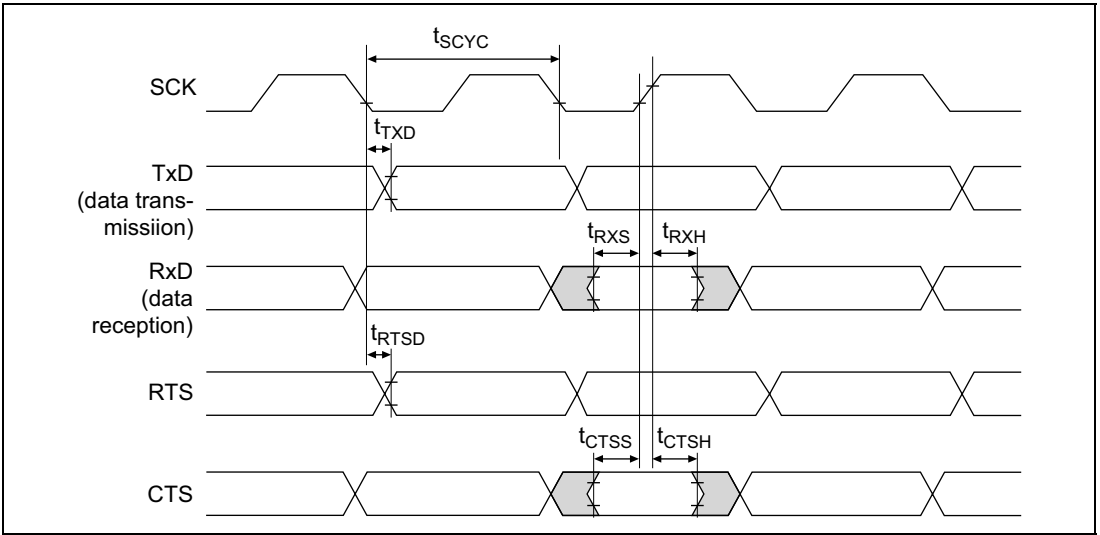

Figure 23.51 SCI I/O Timing in Clock Synchronous Mode

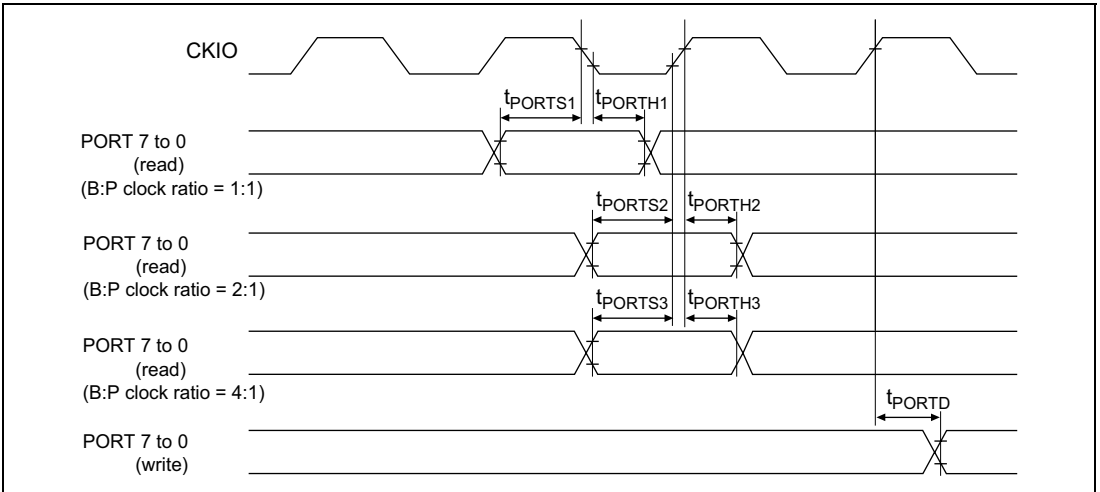

Figure 23.52 I/O Port Timing

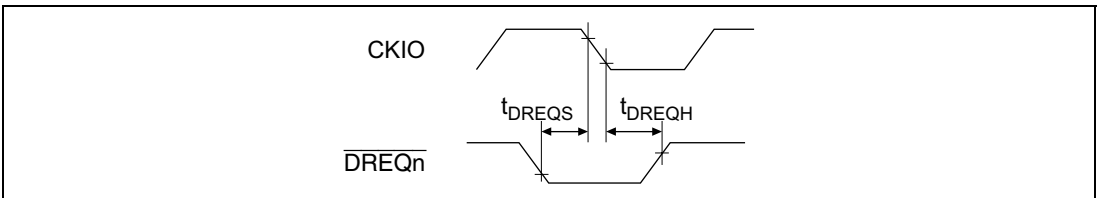

Figure 23.53 \overline{DREQ} Input Timing

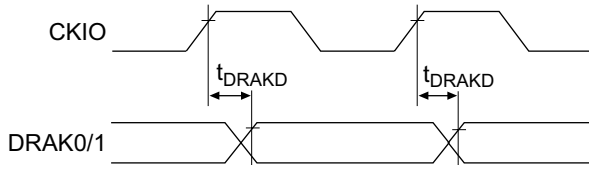

Figure 23.54 DRAK Output Timing

23.3.9 UDI-Related Pin Timing

Table 23.9 UDI-Related Pin Timing

$V_{ccQ} = 3.3 \pm 0.3V$, $V_{cc} = 1.55$ to $2.15 V$, $AV_{cc} = 3.3 \pm 0.3V$, $T_a = -20$ to $75^\circ C$

Item	Symbol	Min	Max	Unit	Figure
TCK cycle time	t_{TCKCYC}	50	—	ns	23.55
TCK high pulse width	t_{TCKH}	12	—	ns	
TCK low pulse width	t_{TCKL}	12	—	ns	
TCK rise/fall time	t_{TCKf}	—	4	ns	
\overline{TRST} setup time	t_{TRSTS}	12	—	ns	23.56
\overline{TRST} hold time	t_{TRSTH}	50	—	t_{cyc}	
TDI setup time	t_{TDIS}	10	—	ns	23.57
TDI hold time	t_{TDIH}	10	—	ns	
TMS setup time	t_{TMSS}	10	—	ns	
TMS hold time	t_{TMSH}	10	—	ns	
TDO delay time	t_{TDOD}	—	16	ns	
$\overline{ASEMD0}$ setup time	t_{ASEMDH}	12	—	ns	23.58
$\overline{ASEMD0}$ hold time	t_{ASEMDS}	12	—	ns	

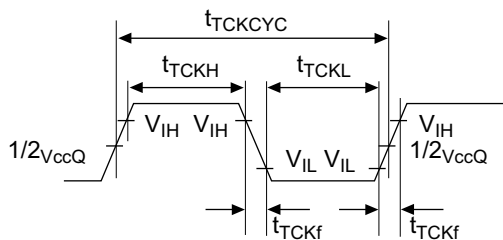

Note: When clock is input from TCK pin

Figure 23.55 TCK Input Timing

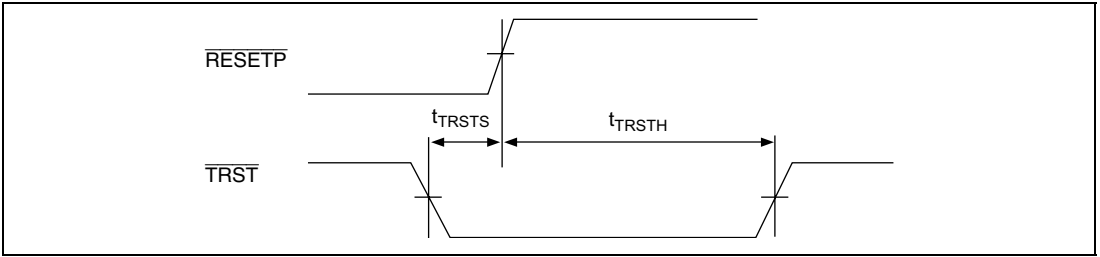

Figure 23.56 $\overline{\text{TRST}}$ Input Timing (Reset Hold)

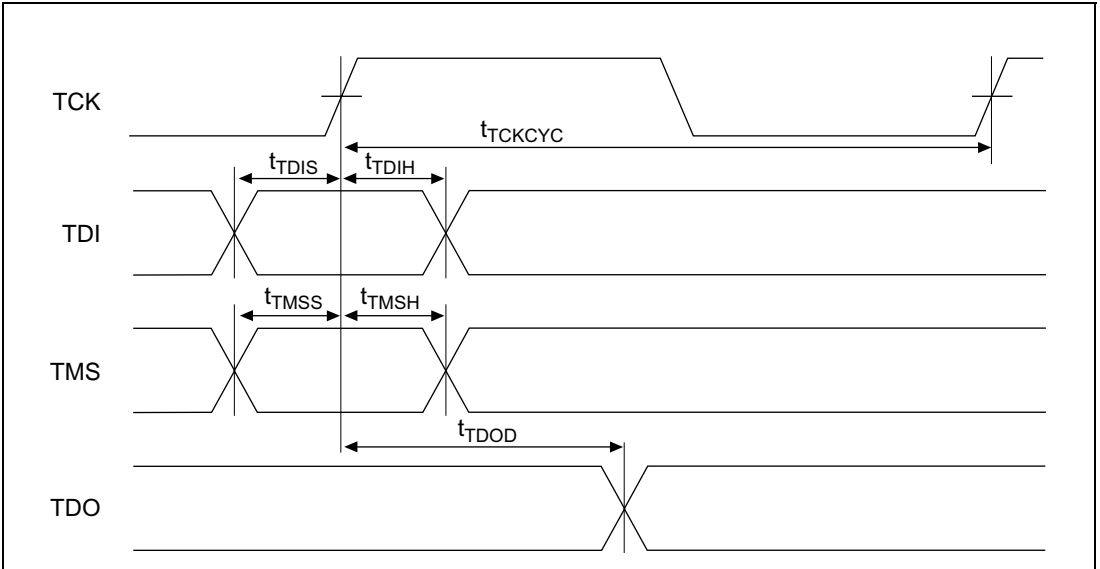

Figure 23.57 UDI Data Transfer Timing

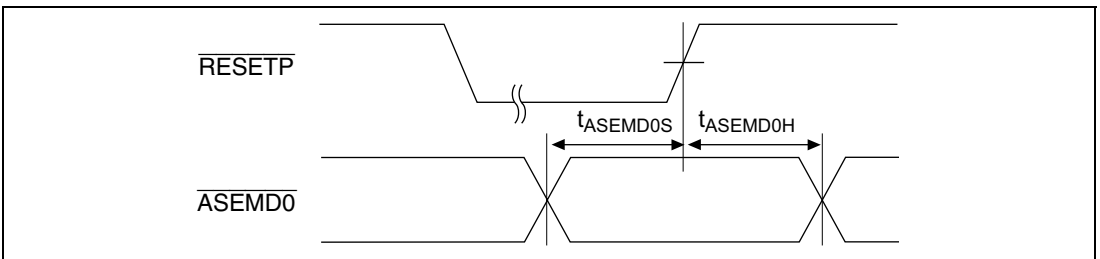
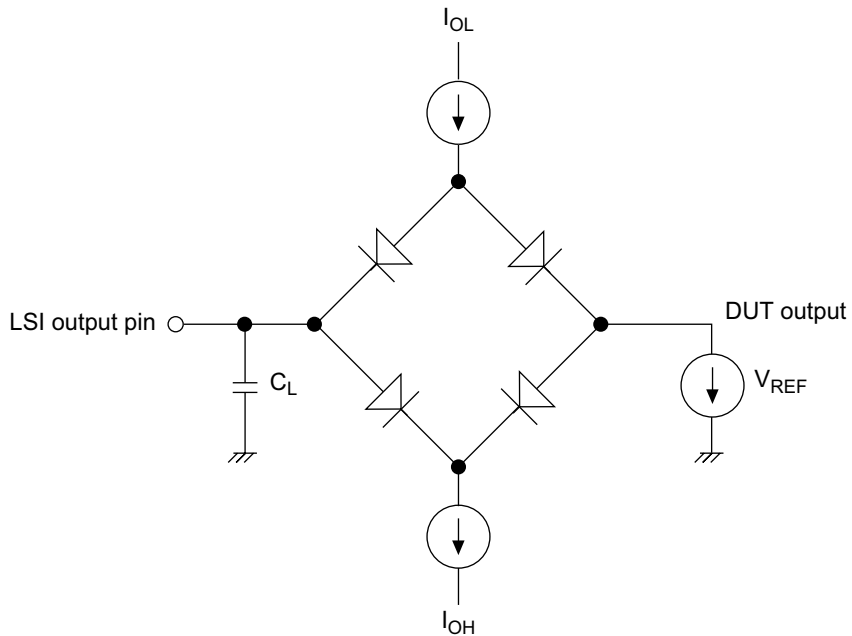

Figure 23.58 $\overline{\text{ASEMDO0}}$ Input Timing

23.3.10 AC Characteristics Measurement Conditions

- I/O signal reference level: $V_{ccQ}/2$ ($V_{ccQ} = 3.3 \pm 0.3$ V, $V_{cc} = 1.55$ to 2.15 V)
- Input pulse level: V_{ss} to 3.0 V (where \overline{RESETP} , \overline{RESETM} , $\overline{ASEND0}$, $\overline{IRLS3}$ to $\overline{IRLS0}$, $\overline{IRL3}$ to $\overline{IRL0}$, \overline{ADTRG} , $\overline{PINT15}$ to $\overline{PINT0}$, \overline{TRST} , $RxD1$, CA , NMI , $\overline{IRQ5}$ – $\overline{IRQ0}$, $CKIO$, and $MD5$ – $MD0$ are within V_{ss} to V_{cc})
- Input rise and fall times: 1 ns



- Notes: 1. C_L is the total value that includes the capacitance of measurement instruments, etc., and is set as follows for each pin.
30pF: $CKIO$, RAS , CAS , $CS0$, $CS2$ – $CS6$, $CE2A$, $CE2B$, $BACK$
50pF: All other pins
2. I_{OL} and I_{OH} are the values shown in table 23.3.

Figure 23.59 Output Load Circuit

23.3.11 Delay Time Variation Due to Load Capacitance

A graph (reference data) of the variation in delay time when a load capacitance greater than that stipulated (30 or 50 pF) is connected to this LSI's pins is shown below. The graph shown in figure 23.60 should be taken into consideration in the design process if the stipulated capacitance is exceeded in connecting an external device.

If the connected load capacitance exceeds the range shown in figure 23.60, the graph will not be a straight line.

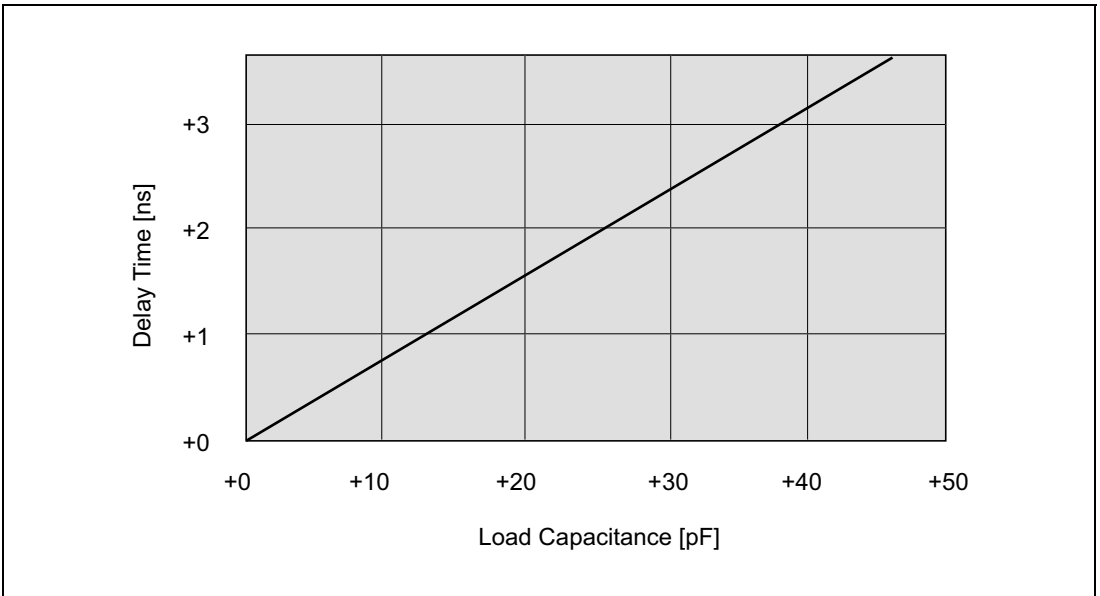

Figure 23.60 Load Capacitance vs. Delay Time

23.4 A/D Converter Characteristics

Table 23.10 lists the A/D converter characteristics.

Table 23.10 A/D Converter Characteristics

$V_{CCQ} = 3.3 \pm 0.3$ V, $V_{CC} = 1.55$ to 2.15 V, $AV_{CC} = 3.3 \pm 0.3$ V, $T_a = -20$ to 75°C

Item	Min	Typ	Max	Unit
Resolution	10	10	10	bits
Conversion time	15	—	—	μs
Analog input capacitance	—	—	20	pF
Permissible signal-source (single-source) impedance	—	—	5	k Ω
Nonlinearity error	—	—	± 3.0	LSB
Offset error	—	—	± 2.0	LSB
Full-scale error	—	—	± 2.0	LSB
Quantization error	—	—	± 0.5	LSB
Absolute accuracy	—	—	± 4.0	LSB

23.5 D/A Converter Characteristics

Table 23.11 lists the D/A converter characteristics.

Table 23.11 D/A Converter Characteristics

$V_{CCQ} = 3.3 \pm 0.3$ V, $V_{CC} = 1.55$ to 2.15 V, $AV_{CC} = 3.3 \pm 0.3$ V, $T_a = -20$ to 75°C

Item	Min	Typ	Max	Unit	Test Conditions
Resolution	8	8	8	bits	
Conversion time	—	—	10.0	μs	20-pF capacitive load
Absolute accuracy	—	± 2.5	± 4.0	LSB	2-M Ω resistance load

Appendix A Pin Functions

A.1 Pin States

Table A.1 shows pin states during resets, power-down states, and the bus-released state.

Table A.1 Pin States during Resets, Power-Down States, and Bus-Released State

Category	Pin	Reset		Power-Down		Bus Released
		Power-On Reset	Manual Reset	Standby	Sleep	
Clock	EXTAL	I	I	I	I	I
	XTAL	O* ¹	O* ¹	O* ¹	O* ¹	O* ¹
	CKIO	IO* ¹	IO* ¹	IO* ¹	IO* ¹	IO* ¹
	EXTAL2	I	I	I	I	I
	XTAL2	O	O	O	O	O
	CAP1, CAP2	—	—	—	—	—
System control	RESETP	I	I	I	I	I
	RESETM	I	I	I	I	I
	BREQ	I	I	I	I	I
	BACK	O	O	O	O	L
	MD[5:0]	I	I	I	I	I
	CA	I	I	I	I	I
	STATUS[1:0]/PTJ[7:6]	O	OP* ²	OP* ²	OP* ²	OP* ²
Interrupt	IRQ[3:0]/IRL[3:0]/PTH[3:0]	V* ⁷	I	I	I	I
	IRQ[4]/ PTH[4]	V* ⁷	I	I	I	I
	NMI	I	I	I	I	I
	IRLS[3:0]/PTF[3:0]/PINT[11:8]	V	I	IZ	I	I
	MCS[7:0]/PTC[7:0]/PINT[7:0]	V	OP* ²	ZH* ¹⁰ K* ²	OP* ²	ZP* ²
	TCK/PTF[4]/PINT[12]	IV	I	IZ	I	I
	TDI/PTF[5]/PINT[13]	IV	I	IZ	I	I
	TMS/PTF[6]/PINT[14]	IV	I	IZ	I	I
	TRST/PTF[7]/PINT[15]	IV	I	IZ	I	I
	IRQOUT	O	O	O	O	O

Category	Pin	Reset		Power-Down		Bus Released
		Power-On Reset	Manual Reset	Standby	Sleep	
Address bus	A[25:0]	Z	O	ZL* ⁹	O	Z
Data bus	D[15:0]	Z	I	Z	IO	Z
	D[23:16]/PTA[7:0]	Z	IP* ²	ZK* ²	IOP* ²	ZP* ²
	D[31:24]/PTB[7:0]	Z	IP* ²	ZK* ²	IOP* ²	ZP* ²
Bus control	CS0/MCS0	H	O	ZH* ¹⁰	O	Z
	CS[2:4]/PTK[0:2]	H	OP* ²	ZH* ¹⁰ K* ²	OP* ²	ZP* ²
	CS5/CE1A/PTK[3]	H	OP* ²	ZH* ¹⁰ K* ²	OP* ²	ZP* ²
	CS6/CE1B	H	O	ZH* ¹⁰	O	Z
	BS/PTK[4]	H	OP* ²	ZH* ¹⁰ K* ²	OP* ²	ZP* ²
	RAS3L/PTJ[0]	H	OP* ²	ZOK* ³	OP* ²	ZOP* ³
	RAS3U/PTE[2]	V	OP* ²	ZOK* ³	OP* ²	ZOP* ³
	CASL/PTJ[2]	H	OP* ²	ZOK* ³	OP* ²	ZOP* ³
	CASU/PTJ[3]	H	OP* ²	ZOK* ³	OP* ²	ZOP* ³
	WE0/DQMLL	H	O	ZH* ¹⁰	O	Z
	WE1/DQMLU/WE	H	O	ZH* ¹⁰	O	Z
	WE2/DQMUL/ICIORD/PTK[6]	H	OP* ²	ZH* ¹⁰ K* ²	OP* ²	ZP* ²
	WE3/DQMUU/ICIOWR/PTK[7]	H	OP* ²	ZH* ¹⁰ K* ²	OP* ²	ZP* ²
	RD/WR	H	O	ZH* ¹⁰	O	Z
	RD	H	O	ZH* ¹⁰	O	Z
	CKE/PTK[5]	H	OP* ²	OK* ²	OP* ²	OP* ²
WAIT	Z	I	Z	I	Z	
DMAC	DREQ0/PTD[4]	V	ZI* ⁶	Z	I	I
	DACK0/PTD[5]	V	OP* ²	ZK* ²	OP* ²	OP* ²
	DRAK0/PTD[1]	V	OP* ²	ZH* ¹⁰ K* ²	OP* ²	OP* ²
	DREQ1/PTD[6]	V	ZI* ⁶	Z	I	I
	DACK1/PTD[7]	V	OP* ²	ZK* ²	OP* ²	OP* ²
	DRAK1/PTD[0]	V	OP* ²	ZH* ¹⁰ K* ²	OP* ²	OP* ²
Timer	TCLK/PTH[7]	V	ZP	IOP* ⁴	IOP* ⁴	IOP* ⁴

Category	Pin	Reset		Power-Down		Bus Released
		Power-On Reset	Manual Reset	Standby	Sleep	
SCI/Smart card without FIFO	RxD0/SCPT[0]	Z	ZI ^{*6}	Z	IZ ^{*5}	IZ ^{*5}
	TxD0/SCPT[0]	Z	ZO ^{*6}	ZK ^{*2}	OZ ^{*5}	OZ ^{*5}
	SCK0/SCPT[1]	V	ZP ^{*2}	ZK ^{*2}	IOP ^{*4}	IOP ^{*4}
SCIF/IrDA with FIFO	RxD1/SCPT[2]	Z	ZI ^{*6}	Z	IZ ^{*5}	IZ ^{*5}
	TxD1/SCPT[2]	Z	ZO ^{*6}	ZK ^{*2}	OZ ^{*5}	OZ ^{*5}
	SCK1/SCPT[3]	V	ZP ^{*2}	ZK ^{*2}	IOP ^{*4}	IOP ^{*4}
SCIF with FIFO	RxD2/SCPT[4]	Z	ZI ^{*6}	Z	IZ ^{*5}	IZ ^{*5}
	TxD2/SCPT[4]	Z	ZO ^{*6}	ZK ^{*2}	OZ ^{*5}	OZ ^{*5}
	SCK2/SCPT[5]	V	ZP ^{*2}	ZK ^{*2}	IOP ^{*4}	IOP ^{*4}
	RTS2/SCPT[6]	V	OP ^{*2}	ZK ^{*2}	OP ^{*2}	OP ^{*2}
	CTS2/IRQ5/SCPT[7]	V ^{*7}	ZI ^{*6}	I	I	I
Port	AUDSYN \bar{C} /PTE[7]	OV	OP ^{*2}	OK ^{*2}	OP ^{*2}	OP ^{*2}
	CE2B \bar{B} /PTE[5]	V	OP ^{*2}	ZH ^{*10} K ^{*2}	OP ^{*2}	ZP ^{*2}
	CE2A \bar{A} /PTE[4]	V	OP ^{*2}	ZH ^{*10} K ^{*2}	OP ^{*2}	ZP ^{*2}
	TDO/PTE[0]	OV	OP ^{*2}	OK ^{*2}	OP ^{*2}	OP ^{*2}
	I \bar{O} IS1 $\bar{6}$ /PTG[7]	V	I	Z	I	I
	PTG[5:0]	V	I	Z	I	I
	AUDCK/PHT[6]	V	I	Z	I	I
	ADTRG \bar{G} /PTH[5]	V ^{*7}	I	IZ	I	I
	WAKEUP \bar{P} /PTD[3]	V	OP ^{*2}	OK ^{*2}	OP ^{*2}	ZP ^{*2}
	RESETOUT/PTD[2]	O	OP ^{*2}	ZK ^{*2}	OP ^{*2}	OP ^{*2}
	AUDATA[3:0]/PTG[3:0]	OV	OK	OK	OK	OK
	CKIO2/PTG[4]	V	OI	OZ	OI	OI
	ASEBRKAK \bar{K} /PTG[5]	OV	OI	OZ	OI	OI
	ASEMD0 \bar{D} /PTG[6]	I	I	Z	I	I
	PTJ[1]	H	OP ^{*2}	ZOK ^{*3}	OP ^{*2}	ZOP ^{*3}
	PTE[1]	V	OP ^{*2}	ZOK ^{*3}	OP ^{*2}	ZOP ^{*3}
	PTE[6]	V	OP ^{*2}	ZOK ^{*3}	OP ^{*2}	ZOP ^{*3}
	PTE[3]	V	OP ^{*2}	ZOK ^{*3}	OP ^{*2}	ZOP ^{*3}
	PTJ[4]	H	OP ^{*2}	ZOK ^{*3}	OP ^{*2}	ZOP ^{*3}
	PTJ[5]	H	OP ^{*2}	ZOK ^{*3}	OP ^{*2}	ZOP ^{*3}

Category	Pin	Reset		Power-Down		Bus Released
		Power-On Reset	Manual Reset	Standby	Sleep	
Analog	AN[5:0]/PTL[5:0]	Z	ZI ^{*6}	Z	I	I
	AN[6:7]/DA[1:0]/PTL[6:7]	Z	ZI ^{*6}	OZ ^{*11}	IO ^{*8}	IO ^{*8}

I: Input

O: Output

H: High-level output

L: Low-level output

Z: High impedance

P: Input or output depending on register setting

K: Input pin is high impedance, output pin holds its state

V: I/O buffer off, pull-up MOS on

- Notes:
1. Depending on the clock mode (MD2–MD0 setting).
 2. K or P when the port function is used.
 3. K or P when the port function is used. Z or O when the port function is not used depending on register setting.
 4. K or P when the port function is used. I or O when the port function is not used depending on register setting.
 5. Depending on register setting.
 6. I or O when the port function is used.
 7. Input Schmitt buffers of IRQ[5.0] and ADTRG on; other input buffers off.
 8. O when DA output is enabled; otherwise I depending on register setting.
 9. In standby mode, Z or L depending on register setting.
 10. In standby mode, Z or H depending on register setting.
 11. O when DA output is enabled; Z otherwise.

A.2 Pin Specifications

Table A.2 shows the pin specifications.

Table A.2 Pin Specifications

Pin	Pin No. (FP-208C, FP-208E)	Pin No. (BP-240A)	I/O	Function
MD5	197	C6	I	Operating mode pin (endian mode)
MD4, MD3	196, 195	D6, A7	I	Operating mode pin (area 0 bus width)
MD2 to MD0	2, 1, 144	C2, D2,G19	I	Operating mode pin (clock mode)
RAS3L/PTJ[0]	106	U18	I/O	RAS (SDRAM) / I/O port
PTJ[1]	107	U19	I/O	I/O port
CE2A/PTE[4]	103	V17	I/O	PCMCIA CE2A / I/O port
CE2B/PTE[5]	104	V16	I/O	PCMCIA CE2B / I/O port
RXD0/SCPT[0]	171	B13	I	Serial port 0 data input / input port
RXD1/SCPT[2]	172	C13	I	Serial port 1 data input / input port
RXD2/SCPT[4]	174	B12	I	Serial port 2 data input / input port
TXD0/SCPT[0]	164	C15	O	Serial port 0 data output / output port
TXD1/SCPT[2]	166	A14	O	Serial port 1 data output / output port
TXD2/SCPT[4]	168	C14	O	Serial port 2 data output / output port
SCK0/SCPT[1]	165	D15	I/O	Serial port 0 clock input/output / I/O port
SCK1/SCPT[3]	167	B14	I/O	Serial port 1 clock input/output / I/O port
SCK2/SCPT[5]	169	D14	I/O	Serial port 2 clock input/output / I/O port
RTS2/SCPT[6]	170	A13	I/O	Serial port 2 transfer request / I/O port
STATUS1/PTJ[7]	158	B17	I/O	Processor state / I/O port
STATUS0/PTJ[6]	157	B16	I/O	Processor state / I/O port

Pin	Pin No. (FP-208C, FP-208E)	Pin No. (BP-240A)	I/O	Function
A25 to A0	86, 84, 82, 80, 78 to 72, 70, 68 to 60, 58, 56 to 53	V12, T12, V11, W10, V10, U9, T9, V9, W9, T8, U8, W8, U7, V7, W7, T6, U6, V6, W6, T5, U5, W5, W4, V5, V3, V4	O	Address bus
D31 to D24/ PTB[7] to PTB[0]	13 to 18, 20, 22	F4, G1, G2, G3, G4, H1, H3, J1	I/O	Data bus / I/O port
D23 to D16/ PTA[7] to PTA[0]	23 to 26, 28, 30 to 32	J2, J4, J3, K2, K1, L2, L1, M4	I/O	Data bus / I/O port
D15 to D0	34, 36 to 44, 46, 48 to 52	M2, N4, N3, N2, N1, P4, P3, P2, P1, R4, T4, T3, T1, R2, U2, T2	I/O	Data bus
$\overline{\text{MCS}}[7:0]/$ $\overline{\text{PTC}}[7:0]/$ $\overline{\text{PINT}}[7:0]$	177 to 180, 185 to 188	B11, D11, C11, B10, D9, B9, A9, D8	I/O	Mask ROM chip select / I/O port / port interrupt request
$\overline{\text{WAKEUP}}/\text{PTD}[3]$	182	D10	I/O	Wakeup / I/O port
$\overline{\text{RESETOUT}}/$ $\text{PTD}[2]$	184	C9	I/O	Reset output / I/O port
$\overline{\text{DRAK0}}/\text{PTD}[1]$	189	C8	I/O	DMA control pin / I/O port
$\overline{\text{DRAK1}}/\text{PTD}[0]$	190	B8	I/O	DMA control pin / I/O port
$\overline{\text{DREQ0}}/\text{PTD}[4]$	191	A8	I	DMA transfer request 0 / input port
$\overline{\text{DREQ1}}/\text{PTD}[6]$	192	D7	I	DMA transfer request 1 / input port
$\overline{\text{AN}}[5:0]/\text{PTL}[5:0]$	204 to 199	C4, A5, D4, C5, D5, A6	I	Analog input pin / input port
$\overline{\text{AN}}[7:6]/\text{DA}[1:0]/$ $\text{PTL}[7:6]$	207, 206	B3, B5	I/O	Analog I/O pin / input port
$\overline{\text{CS6}}/\text{CE1B}$	102	V15	O	Chip select 6 / PCMCIA CE1B
$\overline{\text{CS5}}/\text{CE1A}/$ $\text{PTK}[3]$	101	W16	I/O	Chip select 5 / PCMCIA CE2B / I/O port
$\overline{\text{CS4}}/\text{PTK}[2]$	100	U16	I/O	Chip select 4 / I/O port
$\overline{\text{CS3}}/\text{PTK}[1]$	99	W15	I/O	Chip select 3 / I/O port

Pin	Pin No. (FP-208C, FP-208E)	Pin No. (BP-240A)	I/O	Function
$\overline{CS2}/PTK[0]$	98	T16	I/O	Chip select 2 / I/O port
$\overline{CS0}/MCS0$	96	T15	O	Chip select 0 / Mask ROM chip select 0
$\overline{BS}/PTK[4]$	87	W12	I/O	Bus cycle start / I/O port
PTJ[5]	113	R17	I/O	I/O port
PTJ[4]	112	U17	I/O	I/O port
$\overline{CASU}/PTJ[3]$	110	T17	I/O	CAS(SDRAM) / I/O port
$\overline{CASL}/PTJ[2]$	108	R18	I/O	CAS(SDRAM) / I/O port
$\overline{DACK0}/PTD[5]$	114	R16	I/O	DMA transfer strobe 0 / I/O port
$\overline{DACK1}/PTD[7]$	115	P19	I/O	DMA transfer strobe 1 / I/O port
\overline{RD}	88	T13	O	Read strobe pin
$\overline{WE0}/DQMLL$	89	U13	O	D7–D0 select signal/ DQM(SDRAM)
$\overline{WE1}/DQMLU/\overline{WE}$	90	V13	O	D15–D8 select signal / DQM(SDRAM)/ PCMCIA \overline{WE} signal
$\overline{WE2}/DQMUL/ICIOR\overline{D}/PTK[6]$	91	W13	I/O	D23–D16 select signal / DQM(SDRAM) / PCMCIA \overline{IORD} signal / I/O port
$\overline{WE3}/DQMUU/ICIOR\overline{WR}/PTK[7]$	92	T14	I/O	D31–D24 select signal /DQM(SDRAM) / PCMCIA \overline{IOWR} signal / I/O port
RD/WR	93	U14	O	Read/write select signal
AUDSYN\overline{C}/ PTE[7]	94	V14	I/O	AUD synchronous I/O port
PTE[6]	116	P18	I/O	I/O port
PTE[3]	117	P17	I/O	I/O port
$\overline{RAS3U}/PTE[2]$	118	P16	I/O	RAS(SDRAM) / I/O port
PTE[1]	119	N19	I/O	I/O port
TDO/PTE[0]	120	N18	I/O	Test data output I/O port
\overline{RESETM}	124	M18	I	Manual reset input
ADTRG\overline{C}/PTH[5]	125	M17	I	ADC trigger request / Input port
$\overline{IOIS16}/PTG[7]$	126	M16	I	I/O for PC card / input port
ASMD\overline{O}/PTG[6]	127	L19	I	ASE mode / input port
ASEBRKAK/ PTG[5]	128	L18	I	ASE break accept / input port

Pin	Pin No. (FP-208C, FP-208E)	Pin No. (BP-240A)	I/O	Function
CKIO2/PTG[4]	129	L16	I/O	System clock output / input port
AUDATA[3]/ PTG[3]	130	L17	I	AUD data / input port
AUDATA[2]/ PTG[2]	131	K18	I	AUD data / input port
AUDATA[1]/ PTG[1]	133	K19	I	AUD data / input port
AUDATA[0]/ PTG[0]	135	J18	I	AUD data / input port
TRST/PTF[7]/ PINT[15]	136	J19	I	Test reset / input port / port interrupt request
TMS/PTF[6]/ PINT[14]	137	H16	I	Test mode switch / input port / port interrupt request
TDI/PTF[5]/ PINT[13]	138	H17	I	Test data input / input port / port interrupt request
TCK/PTF[4]/ PINT[12]	139	H18	I	Test clock / input port / port interrupt request
IRLS[3:0]/ PTF[3:0]/ PINT[11:8]	140 to 143	H19, G16, G17, G18	I	External interrupt request / input port / port interrupt request
AUDCK/PTH[6]	151	D16	I	AUD clock / input port
WAIT	123	M19	I	Hardware wait request
BREQ	122	N16	I	Bus request
BACK	121	N17	O	Bus acknowledge
IRQOUT	160	A16	O	Interrupt / refresh request output
RESETP	193	C7	I	Power-on reset input
NMI	7	C3	I	Nonmaskable interrupt request
IRQ[3:0]/IRL[3:0]/ PTH[3:0]	11 to 8	F2, F1, E4, E3	I	External interrupt request / external interrupt source / input port
IRQ4/PTH[4]	12	F3	I	External interrupt request / input port
CTS2/IRQ5/ SCPT[7]	176	A11	I	Serial port 2 transfer enable / external interrupt request / input port
TCLK/PTH[7]	159	B15	I/O	Clock I/O (for TMU/RTC) / I/O port
EXTAL	156	D18	I	External clock / crystal oscillator pin
XTAL	155	C18	O	Crystal oscillator pin
CAP1	146	F17	—	External capacitance pin (for PLL1)
CAP2	149	E16	—	External capacitance pin (for PLL2)

Pin	Pin No. (FP-208C, FP-208E)	Pin No. (BP-240A)	I/O	Function
CKIO	162	A15	I/O	System clock I/O
XTAL2	4	D1	O	Crystal oscillator pin (for on-chip RTC)
EXTAL2	5	D3	I	Crystal oscillator pin (for on-chip RTC)
CKE/PTK[5]	105	T18	I/O	CK enable for SDRAM / I/O port
CA	194	B7	I	Setting hardware standby pin
V _{CCQ}	21, 35, 47, 59, 71, 85, 97, 111, 163, 183	H4, M1, R1, U3, V8, U15, R19, C17, A10, U12	Power supply	Power supply (3.3 V)
V _{CC-RTC}	3	E2	Power supply	RTC oscillator power supply (2.0/1.9/1.8/1.7 V)
V _{CC-PLL1} V _{CC-PLL2}	145 150	F16, E17	Power supply	PLL power supply (2.0/1.9/1.8/1.7 V)
AV _{CC}	205	A4	Power supply	Analog power supply (3.3 V)
V _{SSQ}	19, 33, 45, 57, 69, 83, 95, 109, 161, 181	H2, M3, R3, T7, U4, W11, W14, T19, C16, C10	Power supply	Power supply (0 V)
V _{CC}	29, 81, 134, 154, 175	L3, L4, U11, T11, J17, J16, E18, C19, C12, D12	Power supply	Internal power supply (2.0/1.9/1.8/1.7 V)
V _{SS}	27, 79, 132, 152, 153, 173	K3, K4, U10, T10, K17, K16, E19, D17, D19, A12, D13	Power supply	Internal power supply (0 V)
V _{SS-RTC}	6	E1	Power supply	RTC-oscillator power supply (0 V)
V _{SS-PLL1} V _{SS-PLL2}	147 148	F18 F19	Power supply	PLL power supply (0 V)
AV _{SS}	198, 208	B6, B4	Power supply	Analog power supply (0 V)

Note: Except in hardware standby mode, power must be supplied constantly to all power supply pins. In hardware standby mode, power must be supplied to V_{CC-RTC} and V_{SS-RTC} at least.

A.3 Treatment of Unused Pins

- When RTC is not used
 - EXTAL2: Pull up (2.0/1.9/1.8/1.7 V)
 - XTAL2: Leave unconnected
 - V_{CC}-RTC: Power supply (2.0/1.9/1.8/1.7 V)
 - V_{SS}-RTC: Power supply (0 V)
- When PLL2 is not used
 - CAP2: Leave unconnected
 - V_{CC}-PLL2: Power supply (2.0/1.9/1.8/1.7 V)
 - V_{SS}-PLL2: Power supply (0 V)
- When on-chip crystal oscillator is not used
 - XTAL: Leave unconnected
- When EXTAL pin is not used
 - EXTAL: Pull up (3.3 V)
- When A/D converter is not used
 - AN[7:0]: Leave unconnected
 - AV_{CC}: Power supply (3.3 V)
 - AV_{SS}: Power supply (0 V)
- When UDI is not used
 - ASEMD0: Pull up (3.3 V)

A.4 Pin States in Access to Each Address Space

Table A.3 Pin States (Ordinary Memory/Little Endian)

Pin		8-Bit Bus Width	16-Bit Bus Width		
		Byte/Word/Longword Access	Byte Access (Address 2n)	Byte Access (Address 2n + 1)	Word/Longword Access
CS $\bar{6}$ to CS $\bar{2}$, CS $\bar{0}$		Enabled	Enabled	Enabled	Enabled
RD	R	Low	Low	Low	Low
	W	High	High	High	High
RD/WR	R	High	High	High	High
	W	Low	Low	Low	Low
BS		Enabled	Enabled	Enabled	Enabled
RAS3U/PTE[2]		High	High	High	High
RAS3L/PTJ[0]		High	High	High	High
CASL/PTJ[2]		High	High	High	High
CASU/PTJ[3]		High	High	High	High
WE0/DQMLL	R	High	High	High	High
	W	Low	Low	High	Low
WE1/DQMLU/WE	R	High	High	High	High
	W	High	High	Low	Low
WE2/DQMUL/ICIORD/PTK[6]	R	High	High	High	High
	W	High	High	High	High
WE3/DQMUU/ICIOWR/PTK[7]	R	High	High	High	High
	W	High	High	High	High
CE2A/PTE[4]		High	High	High	High
CE2B/PTE[5]		High	High	High	High
CKE/PTK[5]		Disabled	Disabled	Disabled	Disabled
WAIT		Enabled* ¹	Enabled* ¹	Enabled* ¹	Enabled* ¹
IOIS16/PTG[7]		Disabled	Disabled	Disabled	Disabled
A25 to A0		Address	Address	Address	Address
D7 to D0		Valid data	Valid data	Invalid data	Valid data
D15 to D8		High-Z* ²	Invalid data	Valid data	Valid data
D31 to D16		High-Z* ²	High-Z* ²	High-Z* ²	High-Z* ²

Pin		32-Bit Bus Width						
		Byte Access (Address 4n)	Byte Access (Address 4n + 1)	Byte Access (Address 4n + 2)	Byte Access (Address 4n + 3)	Word Access (Address 4n)	Word Access (Address 4n + 2)	Longword Access
CS6 to CS2, CS0		Enabled	Enabled	Enabled	Enabled	Enabled	Enabled	Enabled
RD	R	Low	Low	Low	Low	Low	Low	Low
	W	High	High	High	High	High	High	High
RD/WR	R	High	High	High	High	High	High	High
	W	Low	Low	Low	Low	Low	Low	Low
BS		Enabled	Enabled	Enabled	Enabled	Enabled	Enabled	Enabled
RAS3U/PTE[2]		High	High	High	High	High	High	High
RAS3L/PTJ[0]		High	High	High	High	High	High	High
CASL/PTJ[2]		High	High	High	High	High	High	High
CASU/PTJ[3]		High	High	High	High	High	High	High
WE0/DQMLL	R	High	High	High	High	High	High	High
	W	Low	High	High	High	Low	High	Low
WE1/DQMLU/WE	R	High	High	High	High	High	High	High
	W	High	Low	High	High	Low	High	Low
WE2/DQMUL/ICIORD/PTK[6]	R	High	High	High	High	High	High	High
	W	High	High	Low	High	High	Low	Low
WE3/DQMUU/ICIORW/PTK[7]	R	High	High	High	High	High	High	High
	W	High	High	High	Low	High	Low	Low
CE2A/PTE[4]		High	High	High	High	High	High	High
CE2B/PTE[5]		High	High	High	High	High	High	High
CKE/PTK[5]		Disabled	Disabled	Disabled	Disabled	Disabled	Disabled	Disabled
WAIT		Enabled*1	Enabled*1	Enabled*1	Enabled*1	Enabled*1	Enabled*1	Enabled*1
IOIS16/PTG[7]		Disabled	Disabled	Disabled	Disabled	Disabled	Disabled	Disabled
A25 to A0		Address	Address	Address	Address	Address	Address	Address
D7 to D0		Valid data	Invalid data	Invalid data	Invalid data	Valid data	Invalid data	Valid data
D15 to D8		Invalid data	Valid data	Invalid data	Invalid data	Valid data	Invalid data	Valid data
D23 to D16		Invalid data	Invalid data	Valid data	Invalid data	Invalid data	Valid data	Valid data
D31 to D24		Invalid data	Invalid data	Invalid data	Valid data	Invalid data	Valid data	Valid data

Notes: 1. Disabled when WCR2 register wait setting is 0.

2. Unused data pins should be switched to the port function, or pulled up.

Table A.4 Pin States (Ordinary Memory/Big Endian)

Pin		8-Bit Bus Width	16-Bit Bus Width		
		Byte/Word/Longword Access	Byte Access (Address 2n)	Byte Access (Address 2n + 1)	Word/Longword Access
CS6 to CS2, CS0		Enabled	Enabled	Enabled	Enabled
RD	R	Low	Low	Low	Low
	W	High	High	High	High
RD/WR	R	High	High	High	High
	W	Low	Low	Low	Low
BS		Enabled	Enabled	Enabled	Enabled
RAS3U/PTE[2]		High	High	High	High
RAS3L/PTJ[0]		High	High	High	High
CASL/PTJ[2]		High	High	High	High
CASU/PTJ[3]		High	High	High	High
WE0/DQMLL	R	High	High	High	High
	W	Low	High	Low	Low
WE1/DQMLU/WE	R	High	High	High	High
	W	High	Low	High	Low
WE2/DQMUL/ICIORD/PTK[6]	R	High	High	High	High
	W	High	High	High	High
WE3/DQMUU/ICIOWR/PTK[7]	R	High	High	High	High
	W	High	High	High	High
CE2A/PTE[4]		High	High	High	High
CE2B/PTE[5]		High	High	High	High
CKE/PTK[5]		Disabled	Disabled	Disabled	Disabled
WAIT		Enabled*1	Enabled*1	Enabled*1	Enabled*1
IOIS16/PTG[7]		Disabled	Disabled	Disabled	Disabled
A25 to A0		Address	Address	Address	Address
D7 to D0		Valid data	Invalid data	Valid data	Valid data
D15 to D8		High-Z*2	Valid data	Invalid data	Valid data
D31 to D16		High-Z*2	High-Z*2	High-Z*2	High-Z*2

Pin		32-Bit Bus Width						
		Byte Access (Address 4n)	Byte Access (Address 4n + 1)	Byte Access (Address 4n + 2)	Byte Access (Address 4n + 3)	Word Access (Address 4n)	Word Access (Address 4n + 2)	Longword Access
CS6 to CS2, CS0		Enabled	Enabled	Enabled	Enabled	Enabled	Enabled	Enabled
RD	R	Low	Low	Low	Low	Low	Low	Low
	W	High	High	High	High	High	High	High
RD/WR	R	High	High	High	High	High	High	High
	W	Low	Low	Low	Low	Low	Low	Low
BS		Enabled	Enabled	Enabled	Enabled	Enabled	Enabled	Enabled
RAS3U/PTE[2]		High	High	High	High	High	High	High
RAS3L/PTJ[0]		High	High	High	High	High	High	High
CASL/PTJ[2]		High	High	High	High	High	High	High
CASU/PTJ[3]		High	High	High	High	High	High	High
WE0/DQMLL	R	High	High	High	High	High	High	High
	W	High	High	High	Low	High	Low	Low
WE1/DQMLU/WE	R	High	High	High	High	High	High	High
	W	High	High	Low	High	High	Low	Low
WE2/DQMUL/ICIORD/PTK[6]	R	High	High	High	High	High	High	High
	W	High	Low	High	High	Low	High	Low
WE3/DQMUU/ICIOWR/PTK[7]	R	High	High	High	High	High	High	High
	W	Low	High	High	High	Low	High	Low
CE2A/PTE[4]		High	High	High	High	High	High	High
CE2B/PTE[5]		High	High	High	High	High	High	High
CKE/PTK[5]		Disabled	Disabled	Disabled	Disabled	Disabled	Disabled	Disabled
WAIT		Enabled*1	Enabled*1	Enabled*1	Enabled*1	Enabled*1	Enabled*1	Enabled*1
IOIS16/PTG[7]		Disabled	Disabled	Disabled	Disabled	Disabled	Disabled	Disabled
A25 to A0		Address	Address	Address	Address	Address	Address	Address
D7 to D0		Invalid data	Invalid data	Invalid data	Valid data	Invalid data	Valid data	Valid data
D15 to D8		Invalid data	Invalid data	Valid data	Invalid data	Invalid data	Valid data	Valid data
D23 to D16		Invalid data	Valid data	Invalid data	Invalid data	Valid data	Invalid data	Valid data
D31 to D24		Valid data	Invalid data	Invalid data	Invalid data	Valid data	Invalid data	Valid data

Notes: 1. Disabled when WCR2 register wait setting is 0.

2. Unused data pins should be switched to the port function, or pulled up.

Table A.5 Pin States (Burst ROM/Little Endian)

Pin		8-Bit Bus Width	16-Bit Bus Width		
		Byte/Word/Longword Access	Byte Access (Address 2n)	Byte Access (Address 2n + 1)	Word/Longword Access
CS6 to CS2, CS0		Enabled	Enabled	Enabled	Enabled
RD	R	Low	Low	Low	Low
	W	—	—	—	—
RD/WR	R	High	High	High	High
	W	—	—	—	—
BS		Enabled	Enabled	Enabled	Enabled
RAS3U/PTE[2]		High	High	High	High
RAS3L/PTJ[0]		High	High	High	High
CASL/PTJ[2]		High	High	High	High
CASU/PTJ[3]		High	High	High	High
WE0/DQMLL	R	High	High	High	High
	W	—	—	—	—
WE1/DQMLU/WE	R	High	High	High	High
	W	—	—	—	—
WE2/DQMUL/ICIORD/PTK[6]	R	High	High	High	High
	W	—	—	—	—
WE3/DQMUU/ICIOWR/PTK[7]	R	High	High	High	High
	W	—	—	—	—
CE2A/PTE[4]		High	High	High	High
CE2B/PTE[5]		High	High	High	High
CKE/PTK[5]		Disabled	Disabled	Disabled	Disabled
WAIT		Enabled*1	Enabled*1	Enabled*1	Enabled*1
IOIS16/PTG[7]		Disabled	Disabled	Disabled	Disabled
A25 to A0		Address	Address	Address	Address
D7 to D0		Valid data	Valid data	Invalid data	Valid data
D15 to D8		High-Z*2	Invalid data	Valid data	Valid data
D31 to D16		High-Z*2	High-Z*2	High-Z*2	High-Z*2

Pin		32-Bit Bus Width						
		Byte Access (Address 4n)	Byte Access (Address 4n + 1)	Byte Access (Address 4n + 2)	Byte Access (Address 4n + 3)	Word Access (Address 4n)	Word Access (Address 4n + 2)	Longword Access
CS6 to CS2, CS0		Enabled	Enabled	Enabled	Enabled	Enabled	Enabled	Enabled
RD	R	Low	Low	Low	Low	Low	Low	Low
	W	—	—	—	—	—	—	—
RD/WR	R	High	High	High	High	High	High	High
	W	—	—	—	—	—	—	—
BS		Enabled	Enabled	Enabled	Enabled	Enabled	Enabled	Enabled
RAS3U/PTE[2]		High	High	High	High	High	High	High
RAS3L/PTJ[0]		High	High	High	High	High	High	High
CASL/PTJ[2]		High	High	High	High	High	High	High
CASU/PTJ[3]		High	High	High	High	High	High	High
WE0/DQMLL	R	High	High	High	High	High	High	High
	W	—	—	—	—	—	—	—
WE1/DQMLU/WE	R	High	High	High	High	High	High	High
	W	—	—	—	—	—	—	—
WE2/DQMUL/ICIORD/PTK[6]	R	High	High	High	High	High	High	High
	W	—	—	—	—	—	—	—
WE3/DQMUU/ICIORW/PTK[7]	R	High	High	High	High	High	High	High
	W	—	—	—	—	—	—	—
CE2A/PTE[4]		High	High	High	High	High	High	High
CE2B/PTE[5]		High	High	High	High	High	High	High
CKE/PTK[5]		Disabled	Disabled	Disabled	Disabled	Disabled	Disabled	Disabled
WAIT		Enabled*1	Enabled*1	Enabled*1	Enabled*1	Enabled*1	Enabled*1	Enabled*1
IOIS16/PTG[7]		Disabled	Disabled	Disabled	Disabled	Disabled	Disabled	Disabled
A25 to A0		Address	Address	Address	Address	Address	Address	Address
D7 to D0		Valid data	Invalid data	Invalid data	Invalid data	Valid data	Invalid data	Valid data
D15 to D8		Invalid data	Valid data	Invalid data	Invalid data	Valid data	Invalid data	Valid data
D23 to D16		Invalid data	Invalid data	Valid data	Invalid data	Invalid data	Valid data	Valid data
D31 to D24		Invalid data	Invalid data	Invalid data	Valid data	Invalid data	Valid data	Valid data

Notes: 1. Disabled when WCR2 register wait setting is 0.

2. Unused data pins should be switched to the port function, or pulled up.

Table A.6 Pin States (Burst ROM/Big Endian)

Pin		8-Bit Bus Width	16-Bit Bus Width		
		Byte/Word/Longword Access	Byte Access (Address 2n)	Byte Access (Address 2n + 1)	Word/Longword Access
CS6 to CS2, CS0		Enabled	Enabled	Enabled	Enabled
RD	R	Low	Low	Low	Low
	W	—	—	—	—
RD/WR	R	High	High	High	High
	W	—	—	—	—
BS		Enabled	Enabled	Enabled	Enabled
RAS3U/PTE[2]		High	High	High	High
RAS3L/PTJ[0]		High	High	High	High
CASL/PTJ[2]		High	High	High	High
CASU/PTJ[3]		High	High	High	High
WE0/DQMLL	R	High	High	High	High
	W	—	—	—	—
WE1/DQMLU/WE	R	High	High	High	High
	W	—	—	—	—
WE2/DQMUL/ICIORD/PTK[6]	R	High	High	High	High
	W	—	—	—	—
WE3/DQMUU/ICIOWR/PTK[7]	R	High	High	High	High
	W	—	—	—	—
CE2A/PTE[4]		High	High	High	High
CE2B/PTE[5]		High	High	High	High
CKE/PTK[5]		Disabled	Disabled	Disabled	Disabled
WAIT		Enabled*1	Enabled*1	Enabled*1	Enabled*1
IOIS16/PTG[7]		Disabled	Disabled	Disabled	Disabled
A25 to A0		Address	Address	Address	Address
D7 to D0		Valid data	Invalid data	Valid data	Valid data
D15 to D8		High-Z*2	Valid data	Invalid data	Valid data
D31 to D16		High-Z*2	High-Z*2	High-Z*2	High-Z*2

Pin		32-Bit Bus Width						
		Byte Access (Address 4n)	Byte Access (Address 4n + 1)	Byte Access (Address 4n + 2)	Byte Access (Address 4n + 3)	Word Access (Address 4n)	Word Access (Address 4n + 2)	Longword Access
CS6 to CS2, CS0		Enabled	Enabled	Enabled	Enabled	Enabled	Enabled	Enabled
RD	R	Low	Low	Low	Low	Low	Low	Low
	W	—	—	—	—	—	—	—
RD/WR	R	High	High	High	High	High	High	High
	W	—	—	—	—	—	—	—
BS		Enabled	Enabled	Enabled	Enabled	Enabled	Enabled	Enabled
RAS3U/PTE[2]		High	High	High	High	High	High	High
RAS3L/PTJ[0]		High	High	High	High	High	High	High
CASL/PTJ[2]		High	High	High	High	High	High	High
CASU/PTJ[3]		High	High	High	High	High	High	High
WE0/DQMLL	R	High	High	High	High	High	High	High
	W	—	—	—	—	—	—	—
WE1/DQMLU/WE	R	High	High	High	High	High	High	High
	W	—	—	—	—	—	—	—
WE2/DQMUL/ICIORD/PTK[6]	R	High	High	High	High	High	High	High
	W	—	—	—	—	—	—	—
WE3/DQMUU/ICIORW/PTK[7]	R	High	High	High	High	High	High	High
	W	—	—	—	—	—	—	—
CE2A/PTE[4]		High	High	High	High	High	High	High
CE2B/PTE[5]		High	High	High	High	High	High	High
CKE/PTK[5]		Disabled	Disabled	Disabled	Disabled	Disabled	Disabled	Disabled
WAIT		Enabled*1	Enabled*1	Enabled*1	Enabled*1	Enabled*1	Enabled*1	Enabled*1
IOIS16/PTG[7]		Disabled	Disabled	Disabled	Disabled	Disabled	Disabled	Disabled
A25 to A0		Address	Address	Address	Address	Address	Address	Address
D7 to D0		Invalid data	Invalid data	Invalid data	Valid data	Invalid data	Valid data	Valid data
D15 to D8		Invalid data	Invalid data	Valid data	Invalid data	Invalid data	Valid data	Valid data
D23 to D16		Invalid data	Valid data	Invalid data	Invalid data	Valid data	Invalid data	Valid data
D31 to D24		Valid data	Invalid data	Invalid data	Invalid data	Valid data	Invalid data	Valid data

Notes: 1. Disabled when WCR2 register wait setting is 0.

2. Unused data pins should be switched to the port function, or pulled up.

Table A.7 Pin States (Synchronous DRAM/Little Endian)

Pin		32-Bit Bus Width						
		Byte Access (Address 4n)	Byte Access (Address 4n + 1)	Byte Access (Address 4n + 2)	Byte Access (Address 4n + 3)	Word Access (Address 4n)	Word Access (Address 4n + 2)	Longword Access
CS6 to CS2, CS0		Enabled	Enabled	Enabled	Enabled	Enabled	Enabled	Enabled
RD	R	High	High	High	High	High	High	High
	W	High	High	High	High	High	High	High
RD/WR	R	High	High	High	High	High	High	High
	W	Low	Low	Low	Low	Low	Low	Low
BS		Enabled	Enabled	Enabled	Enabled	Enabled	Enabled	Enabled
RAS3U/PTE[2]		High/Low*1	High/Low*1	High/Low*1	High/Low*1	High/Low*1	High/Low*1	High/Low*1
RAS3L/PTJ[0]		Low/High*1	Low/High*1	Low/High*1	Low/High*1	Low/High*1	Low/High*1	Low/High*1
CASL/PTJ[2]		Low	Low	Low	Low	Low	Low	Low
CASU/PTJ[3]		High	High	High	High	High	High	High
WE0/DQMLL	R	Low	High	High	High	Low	High	Low
	W	Low	High	High	High	Low	High	Low
WE1/DQMLU/WE	R	High	Low	High	High	Low	High	Low
	W	High	Low	High	High	Low	High	Low
WE2/DQMUL/ICIORD/PTK[6]	R	High	High	Low	High	High	Low	Low
	W	High	High	Low	High	High	Low	Low
WE3/DQMUU/ICIOWR/PTK[7]	R	High	High	High	Low	High	Low	Low
	W	High	High	High	Low	High	Low	Low
CE2A/PTE[4]		High	High	High	High	High	High	High
CE2B/PTE[5]		High	High	High	High	High	High	High
CKE/PTK[5]		High*2	High*2	High*2	High*2	High*2	High*2	High*2
WAIT		Disabled	Disabled	Disabled	Disabled	Disabled	Disabled	Disabled
IOIS16/PTG[7]		Disabled	Disabled	Disabled	Disabled	Disabled	Disabled	Disabled
A25 to A0		Address command	Address command	Address command	Address command	Address command	Address command	Address command
D7 to D0		Valid data	Invalid data	Invalid data	Invalid data	Valid data	Invalid data	Valid data
D15 to D8		Invalid data	Valid data	Invalid data	Invalid data	Valid data	Invalid data	Valid data
D23 to D16		Invalid data	Invalid data	Valid data	Invalid data	Invalid data	Valid data	Valid data
D31 to D24		Invalid data	Invalid data	Invalid data	Valid data	Invalid data	Valid data	Valid data

Notes: 1. Lower 32-MB access/ Upper 32-MB access/64-MB access

2. Normally high. Low in self-refreshing.

Table A.8 Pin States (Synchronous DRAM/Big Endian)

Pin		32-Bit Bus Width						
		Byte Access (Address 4n)	Byte Access (Address 4n + 1)	Byte Access (Address 4n + 2)	Byte Access (Address 4n + 3)	Word Access (Address 4n)	Word Access (Address 4n + 2)	Longword Access
CS6 to CS2, CS0		Enabled	Enabled	Enabled	Enabled	Enabled	Enabled	Enabled
RD	R	High	High	High	High	High	High	High
	W	High	High	High	High	High	High	High
RD/WR	R	High	High	High	High	High	High	High
	W	Low	Low	Low	Low	Low	Low	Low
BS		Enabled	Enabled	Enabled	Enabled	Enabled	Enabled	Enabled
RAS3U/PTE[2]		High/Low*1	High/Low*1	High/Low*1	High/Low*1	High/Low*1	High/Low*1	High/Low*1
RAS3L/PTJ[0]		Low/High*1	Low/High*1	Low/High*1	Low/High*1	Low/High*1	Low/High*1	Low/High*1
CASL/PTJ[2]		Low	Low	Low	Low	Low	Low	Low
CASU/PTJ[3]		High	High	High	High	High	High	High
WE0/DQMLL	R	High	High	High	Low	High	Low	Low
	W	High	High	High	Low	High	Low	Low
WE1/DQMLU/WE	R	High	High	Low	High	High	Low	Low
	W	High	High	Low	High	High	Low	Low
WE2/DQMUL/ICORD/PTK[6]	R	High	Low	High	High	Low	High	Low
	W	High	Low	High	High	Low	High	Low
WE3/DQMUU/ICOWR/PTK[7]	R	Low	High	High	High	Low	High	Low
	W	Low	High	High	High	Low	High	Low
CE2A/PTE[4]		High	High	High	High	High	High	High
CE2B/PTE[5]		High	High	High	High	High	High	High
CKE/PTK[5]		High*2	High*2	High*2	High*2	High*2	High*2	High*2
WAIT		Disabled	Disabled	Disabled	Disabled	Disabled	Disabled	Disabled
IOIS16/PTG[7]		Disabled	Disabled	Disabled	Disabled	Disabled	Disabled	Disabled
A25 to A0		Address command	Address command	Address command	Address command	Address command	Address command	Address command
D7 to D0		Invalid data	Invalid data	Invalid data	Valid data	Invalid data	Valid data	Valid data
D15 to D8		Invalid data	Invalid data	Valid data	Invalid data	Invalid data	Valid data	Valid data
D23 to D16		Invalid data	Valid data	Invalid data	Invalid data	Valid data	Invalid data	Valid data
D31 to D24		Valid data	Invalid data	Invalid data	Invalid data	Valid data	Invalid data	Valid data

Notes: 1. Lower 32-MB access/ Upper 32-MB access/64-MB access

2. Normally high. Low in self-refreshing.

Table A.9 Pin States (PCMCIA/Little Endian)

Pin		PCMCIA Memory Interface (Area 5)				PCMCIA/IO Interface (Area 5)			
		8-Bit Bus Width	16-Bit Bus Width			8-Bit Bus Width	16-Bit Bus Width		
		Byte/Word/Long-word Access	Byte Access (Address 2n)	Byte Access (Address 2n + 1)	Word/Long-word Access	Byte/Word/Long-word Access	Byte Access (Address 2n)	Byte Access (Address 2n + 1)	Word/Long-word Access
CS6 to CS2, CS0		Enabled	Enabled	High	Enabled	Enabled	Enabled	High	Enabled
RD	R	Low	Low	Low	Low	High	High	High	High
	W	High	High	High	High	High	High	High	High
RD/WR	R	High	High	High	High	High	High	High	High
	W	Low	Low	Low	Low	Low	Low	Low	Low
BS		Enabled	Enabled	Enabled	Enabled	Enabled	Enabled	Enabled	Enabled
RAS3U/PTE[2]		High	High	High	High	High	High	High	High
RAS3L/PTJ[0]		High	High	High	High	High	High	High	High
CASL/PTJ[2]		High	High	High	High	High	High	High	High
CASU/PTJ[3]		High	High	High	High	High	High	High	High
WE0/DQMLL	R	High	High	High	High	High	High	High	High
	W	High	High	High	High	High	High	High	High
WE1/DQMLU/WE	R	High	High	High	High	High	High	High	High
	W	Low	Low	Low	Low	High	High	High	High
WE2/DQMUL/ICORD/PTK[6]	R	High	High	High	High	Low	Low	Low	Low
	W	High	High	High	High	High	High	High	High
WE3/DQMUU/ICIORW/PTK[7]	R	High	High	High	High	High	High	High	High
	W	High	High	High	High	Low	Low	Low	Low
CE2A/PTE[4]		High	High	Low	Low	High	High	Low	Low
CE2B/PTE[5]		High	High	High	High	High	High	High	High
CKE/PTK[5]		Disabled	Disabled	Disabled	Disabled	Disabled	Disabled	Disabled	Disabled
WAIT		Enabled*1	Enabled*1	Enabled*1	Enabled*1	Enabled*1	Enabled*1	Enabled*1	Enabled*1
IOIS16/PTG[7]		Disabled	Disabled	Disabled	Disabled	Disabled	Disabled	Enabled	Enabled
A25 to A0		Address	Address	Address	Address	Address	Address	Address	Address
D7 to D0		Valid data	Valid data	Invalid data	Valid data	Valid data	Valid data	Invalid data	Valid data
D15 to D8		High-Z*2	Invalid data	Valid data	Valid data	High-Z*2	Invalid data	Valid data	Valid data
D31 to D16		High-Z*2	High-Z*2	High-Z*2	High-Z*2	High-Z*2	High-Z*2	High-Z*2	High-Z*2

Pin		PCMCIA Memory Interface (Area 6)				PCMCIA/IO Interface (Area 6)			
		8-Bit Bus Width	16-Bit Bus Width			8-Bit Bus Width	16-Bit Bus Width		
		Byte/Word/Long-word Access	Byte Access (Address 2n)	Byte Access (Address 2n + 1)	Word/Long-word Access	Byte/Word/Long-word Access	Byte Access (Address 2n)	Byte Access (Address 2n+1)	Word/Long-word Access
CS6 to CS2, CS0		Enabled	Enabled	High	Enabled	Enabled	Enabled	High	Enabled
RD	R	Low	Low	Low	Low	High	High	High	High
	W	High	High	High	High	High	High	High	High
RD/WR	R	High	High	High	High	High	High	High	High
	W	Low	Low	Low	Low	Low	Low	Low	Low
BS		Enabled	Enabled	Enabled	Enabled	Enabled	Enabled	Enabled	Enabled
RAS3U/PTE[2]		High	High	High	High	High	High	High	High
RAS3L/PTJ[0]		High	High	High	High	High	High	High	High
CASL/PTJ[2]		High	High	High	High	High	High	High	High
CASU/PTJ[3]		High	High	High	High	High	High	High	High
WE0/DQMLL	R	High	High	High	High	High	High	High	High
	W	High	High	High	High	High	High	High	High
WE1/DQMLU/WE	R	High	High	High	High	High	High	High	High
	W	Low	Low	Low	Low	High	High	High	High
WE2/DQMUL/ICIORD/PTK[6]	R	High	High	High	High	Low	Low	Low	Low
	W	High	High	High	High	High	High	High	High
WE3/DQMUU/CIOWR/PTK[7]	R	High	High	High	High	High	High	High	High
	W	High	High	High	High	Low	Low	Low	Low
CE2A/PTE[4]		High	High	High	High	High	High	High	High
CE2B/PTE[5]		High	High	Low	Low	High	High	Low	Low
CKE/PTK[5]		Disabled	Disabled	Disabled	Disabled	Disabled	Disabled	Disabled	Disabled
WAIT		Enabled*1	Enabled*1	Enabled*1	Enabled*1	Enabled*1	Enabled*1	Enabled*1	Enabled*1
IOIS16/PTG[7]		Disabled	Disabled	Disabled	Disabled	Disabled	Disabled	Enabled	Enabled
A25 to A0		Address	Address	Address	Address	Address	Address	Address	Address
D7 to D0		Valid data	Valid data	Invalid data	Valid data	Valid data	Valid data	Invalid data	Valid data
D15 to D8		High-Z*2	Invalid data	Valid data	Valid data	High-Z*2	Invalid data	Valid data	Valid data
D31 to D16		High-Z*2	High-Z*2	High-Z*2	High-Z*2	High-Z*2	High-Z*2	High-Z*2	High-Z*2

Notes: 1. Disabled when WCR2 register wait setting is 0.

2. Unused data pins should be switched to the port function, or pulled up.

Table A.10 Pin States (PCMCIA/Big Endian)

Pin	PCMCIA Memory Interface (Area 5)				PCMCIA I/O Interface (Area 5)				
	8-Bit Bus Width	16-Bit Bus Width			8-Bit Bus Width	16-Bit Bus Width			
	Byte/Word/Long-word Access	Byte Access (Address 2n)	Byte Access (Address 2n + 1)	Word/Long-word Access	Byte/Word/Long-word Access	Byte Access (Address 2n)	Byte Access (Address 2n + 1)	Word/Long-word Access	
$\overline{CS6}$ to $\overline{CS2}$, $\overline{CS0}$	Enabled	Enabled	High	Enabled	Enabled	Enabled	High	Enabled	
\overline{RD}	R	Low	Low	Low	Low	High	High	High	High
	W	High	High	High	High	High	High	High	High
$\overline{RD}/\overline{WR}$	R	High	High	High	High	High	High	High	High
	W	Low	Low	Low	Low	Low	Low	Low	Low
\overline{BS}	Enabled	Enabled	Enabled	Enabled	Enabled	Enabled	Enabled	Enabled	
$\overline{RAS3U}/PTE[2]$	High	High	High	High	High	High	High	High	
$\overline{RAS3L}/PTJ[0]$	High	High	High	High	High	High	High	High	
$\overline{CASL}/PTJ[2]$	High	High	High	High	High	High	High	High	
$\overline{CASU}/PTJ[3]$	High	High	High	High	High	High	High	High	
$\overline{WE0}/DQMLL$	R	High	High	High	High	High	High	High	High
	W	High	High	High	High	High	High	High	High
$\overline{WE1}/DQMLU/\overline{WE}$	R	High	High	High	High	High	High	High	High
	W	Low	Low	Low	Low	High	High	High	High
$\overline{WE2}/DQMUL/\overline{ICIORD}/PTK[6]$	R	High	High	High	High	Low	Low	Low	Low
	W	High	High	High	High	High	High	High	High
$\overline{WE3}/DQMUU/\overline{ICIOWR}/PTK[7]$	R	High	High	High	High	High	High	High	High
	W	High	High	High	High	Low	Low	Low	Low
$\overline{CE2A}/PTE[4]$	High	High	Low	Low	High	High	Low	Low	
$\overline{CE2B}/PTE[5]$	High	High	High	High	High	High	High	High	
$\overline{CKE}/PTK[5]$	Disabled	Disabled	Disabled	Disabled	Disabled	Disabled	Disabled	Disabled	
\overline{WAIT}	Enabled*1	Enabled*1	Enabled*1	Enabled*1	Enabled*1	Enabled*1	Enabled*1	Enabled*1	
$\overline{IOIS16}/PTG[7]$	Disabled	Disabled	Disabled	Disabled	Disabled	Disabled	Disabled	Disabled	
A25 to A0	Address	Address	Address	Address	Address	Address	Address	Address	
D7 to D0	Valid data	Invalid data	Valid data	Valid data	Valid data	Invalid data	Valid data	Valid data	
D15 to D8	High-Z*2	Valid data	Invalid data	Valid data	High-Z*2	Valid data	Invalid data	Valid data	
D31 to D16	High-Z*2	High-Z*2	High-Z*2	High-Z*2	High-Z*2	High-Z*2	High-Z*2	High-Z*2	

Pin		PCMCIA Memory Interface (Area 6)				PCMCIA/IO Interface (Area 6)			
		8-Bit Bus Width	16-Bit Bus Width			8-Bit Bus Width	16-Bit Bus Width		
		Byte/Word/Long-word Access	Byte Access (Address 2n)	Byte Access (Address 2n + 1)	Word/Long-word Access	Byte/Word/Long-word Access	Byte Access (Address 2n)	Byte Access (Address 2n+1)	Word/Long-word Access
CS6 to CS2, CS0		Enabled	Enabled	High	Enabled	Enabled	Enabled	High	Enabled
RD	R	Low	Low	Low	Low	High	High	High	High
	W	High	High	High	High	High	High	High	High
RD/WR	R	High	High	High	High	High	High	High	High
	W	Low	Low	Low	Low	Low	Low	Low	Low
BS		Enabled	Enabled	Enabled	Enabled	Enabled	Enabled	Enabled	Enabled
RAS3U/PTE[2]		High	High	High	High	High	High	High	High
RAS3L/PTJ[0]		High	High	High	High	High	High	High	High
CASL/PTJ[2]		High	High	High	High	High	High	High	High
CASU/PTJ[3]		High	High	High	High	High	High	High	High
WE0/DQMLL	R	High	High	High	High	High	High	High	High
	W	High	High	High	High	High	High	High	High
WE1/DQMLU/WE	R	High	High	High	High	High	High	High	High
	W	Low	Low	Low	Low	High	High	High	High
WE2/DQMUL/ICIORD/PTK[6]	R	High	High	High	High	Low	Low	Low	Low
	W	High	High	High	High	High	High	High	High
WE3/DQMUU/ICIORW/PTK[7]	R	High	High	High	High	High	High	High	High
	W	High	High	High	High	Low	Low	Low	Low
CE2A/PTE[4]		High	High	High	High	High	High	High	High
CE2B/PTE[5]		High	High	Low	Low	High	High	Low	Low
CKE/PTK[5]		Disabled	Disabled	Disabled	Disabled	Disabled	Disabled	Disabled	Disabled
WAIT		Enabled*1	Enabled*1	Enabled*1	Enabled*1	Enabled*1	Enabled*1	Enabled*1	Enabled*1
IOIS16/PTG[7]		Disabled	Disabled	Disabled	Disabled	Disabled	Disabled	Enabled	Enabled
A25 to A0		Address	Address	Address	Address	Address	Address	Address	Address
D7 to D0		Valid data	Invalid data	Valid data	Valid data	Valid data	Invalid data	Valid data	Valid data
D15 to D8		High-Z*2	Valid data	Invalid data	Valid data	High-Z*2	Valid data	Invalid data	Valid data
D31 to D16		High-Z*2	High-Z*2	High-Z*2	High-Z*2	High-Z*2	High-Z*2	High-Z*2	High-Z*2

Notes: 1. Disabled when WCR2 register wait setting is 0.

2. Unused data pins should be switched to the port function, or pulled up.

Appendix B Memory-Mapped Control Registers

B.1 Register Address Map

Table B.1 Memory-Mapped Control Registers

Control Register	Module* ¹	Bus* ²	Address* ⁴	Size (Bits)	Access Size (Bits) ³ .
PTEH	CCN	L	FFFFFFF0	32	32
PTEL	CCN	L	FFFFFFF4	32	32
TTB	CCN	L	FFFFFFF8	32	32
TEA	CCN	L	FFFFFFFC	32	32
MMUCR	CCN	L	FFFFFFE0	32	32
BASRA	CCN	L	FFFFFFE4	32	32
BASRB	CCN	L	FFFFFFE8	32	32
CCR	CCN	L	FFFFFFEC	32	32
CCR2	CCN	I	4000B0	32	32
TRA	CCN	L	FFFFFFD0	32	32
EXPEVT	CCN	L	FFFFFFD4	32	32
INTEVT	CCN	L	FFFFFFD8	32	32
BARA	UBC	L	FFFFFFB0	32	32
BAMRA	UBC	L	FFFFFFB4	32	32
BBRA	UBC	L	FFFFFFB8	16	16
BARB	UBC	L	FFFFFFA0	32	32
BAMRB	UBC	L	FFFFFFA4	32	32
BBRB	UBC	L	FFFFFFA8	16	16
BDRB	UBC	L	FFFFFF90	32	32
BDMRB	UBC	L	FFFFFF94	32	32
BRCR	UBC	L	FFFFFF98	16	16
BETR	UBC	L	FFFFFF9C	16	16
BRSR	UBC	L	FFFFFFAC	32	32
BRDR	UBC	L	FFFFFFBC	32	32
FRQCR	CPG	I	FFFFFF80	16	16
STBCR	CPG	I	FFFFFF82	8	8
STBCR2	CPG	I	FFFFFF88	8	8
WTCNT	CPG	I	FFFFFF84	8	16

Control Register	Module* ¹	Bus* ²	Address* ⁴	Size (Bits)	Access Size (Bits)* ³
WTCSR	CPG	I	FFFFFF86	8	16
BCR1	BSC	I	FFFFFF60	16	16
BCR2	BSC	I	FFFFFF62	16	16
WCR1	BSC	I	FFFFFF64	16	16
WCR2	BSC	I	FFFFFF66	16	16
MCR	BSC	I	FFFFFF68	16	16
PCR	BSC	I	FFFFFF6C	16	16
RTCSR	BSC	I	FFFFFF6E	16	16
RTCNT	BSC	I	FFFFFF70	16	16
RTCOR	BSC	I	FFFFFF72	16	16
RFCR	BSC	I	FFFFFF74	16	16
SDMR	BSC	I	FFFD000– FFFFFFF	—	8
MCSCR0	BSC	I	FFFFFF50	16	16
MCSCR1	BSC	I	FFFFFF52	16	16
MCSCR2	BSC	I	FFFFFF54	16	16
MCSCR3	BSC	I	FFFFFF56	16	16
MCSCR4	BSC	I	FFFFFF58	16	16
MCSCR5	BSC	I	FFFFFF5A	16	16
MCSCR6	BSC	I	FFFFFF5C	16	16
MCSCR7	BSC	I	FFFFFF5E	16	16
R64CNT	RTC	P	FFFFFEC0	8	8
RSECCNT	RTC	P	FFFFFEC2	8	8
RMINCNT	RTC	P	FFFFFEC4	8	8
RHRCNT	RTC	P	FFFFFEC6	8	8
RWKCNT	RTC	P	FFFFFEC8	8	8
RDAYCNT	RTC	P	FFFFFECA	8	8
RMONCNT	RTC	P	FFFFFECC	8	8
RYRCNT	RTC	P	FFFFFECE	8	8
RSECAR	RTC	P	FFFFFED0	8	8
RMINAR	RTC	P	FFFFFED2	8	8
RHRAR	RTC	P	FFFFFED4	8	8

Control Register	Module* ¹	Bus* ²	Address* ⁴	Size (Bits)	Access Size (Bits)* ³
RWKAR	RTC	P	FFFFFFED6	8	8
RDAYAR	RTC	P	FFFFFFED8	8	8
RMONAR	RTC	P	FFFFFFEDA	8	8
RCR1	RTC	P	FFFFFFEDC	8	8
RCR2	RTC	P	FFFFFFEDE	8	8
ICR0	INTC	I	FFFFFFEE0	16	16
IPRA	INTC	I	FFFFFFEE2	16	16
IPRB	INTC	I	FFFFFFEE4	16	16
TOCR	TMU	P	FFFFFFE90	8	8
TSTR	TMU	P	FFFFFFE92	8	8
TCOR0	TMU	P	FFFFFFE94	32	32
TCNT0	TMU	P	FFFFFFE98	32	32
TCR0	TMU	P	FFFFFFE9C	16	16
TCOR1	TMU	P	FFFFFFEA0	32	32
TCNT1	TMU	P	FFFFFFEA4	32	32
TCR1	TMU	P	FFFFFFEA8	16	16
TCOR2	TMU	P	FFFFFFEAC	32	32
TCNT2	TMU	P	FFFFFFEB0	32	32
TCR2	TMU	P	FFFFFFEB4	16	16
TCPR2	TMU	P	FFFFFFEB8	32	32
SCSMR	SCI	P	FFFFFFE80	8	8
SCBRR	SCI	P	FFFFFFE82	8	8
SCSCR	SCI	P	FFFFFFE84	8	8
SCTDR	SCI	P	FFFFFFE86	8	8
SCSSR	SCI	P	FFFFFFE88	8	8
SCRDR	SCI	P	FFFFFFE8A	8	8
SCSCMR	SCI	P	FFFFFFE8C	8	8
INTEVT2	INTC	I	4000000	32	32
IRR0	INTC	I	4000004	16	8
IRR1	INTC	I	4000006	16	8
IRR2	INTC	I	4000008	16	8

Control Register	Module ^{*1}	Bus ^{*2}	Address ^{*4}	Size (Bits)	Access Size (Bits) ^{*3}
ICR1	INTC	I	4000010	16	16
ICR2	INTC	I	4000012	16	16
PINTER	INTC	I	4000014	16	16
IPRC	INTC	I	4000016	16	16
IPRD	INTC	I	4000018	16	16
IPRE	INTC	I	400001A	16	16
SAR0	DMAC	P	4000020	32	16,32
DAR0	DMAC	P	4000024	32	16,32
DMATCR0	DMAC	P	4000028	32	16,32
CHCR0	DMAC	P	400002C	32	8,16,32
SAR1	DMAC	P	4000030	32	16,32
DAR1	DMAC	P	4000034	32	16,32
DMATCR1	DMAC	P	4000038	32	16,32
CHCR1	DMAC	P	400003C	32	8,16,32
SAR2	DMAC	P	4000040	32	16,32
DAR2	DMAC	P	4000044	32	16,32
DMATCR2	DMAC	P	4000048	32	16,32
CHCR2	DMAC	P	400004C	32	8,16,32
SAR3	DMAC	P	4000050	32	16,32
DAR3	DMAC	P	4000054	32	16,32
DMATCR3	DMAC	P	4000058	32	16,32
CHCR3	DMAC	P	400005C	32	8,16,32
DMAOR	DMAC	P	4000060	16	8,16
CMSTR	CMT	P	4000070	16	8,16,32
CMCSR	CMT	P	4000072	16	8,16,32
CMCNT	CMT	P	4000074	16	8,16,32
CMCOR	CMT	P	4000076	16	8,16,32
ADDRAH	A/D	P	4000080	8	8,16,32 ^{*5} ^{*6}
ADDRAL	A/D	P	4000082	8	8,16 ^{*5}
ADDRBH	A/D	P	4000084	8	8,16,32 ^{*5} ^{*6}
ADDRBL	A/D	P	4000086	8	8,16 ^{*5}
ADDRCH	A/D	P	4000088	8	8,16,32 ^{*5} ^{*6}

Control Register	Module* ¹	Bus* ²	Address* ⁴	Size (Bits)	Access Size (Bits)* ³
ADDRCL	A/D	P	400008A	8	8,16* ⁵
ADDRDH	A/D	P	400008C	8	8,16,32* ⁵ * ⁶
ADDRDL	A/D	P	400008E	8	8,16* ⁵
ADCSR	A/D	P	4000090	8	8,16,32* ⁵ * ⁶
ADCR	A/D	P	4000092	8	8,16
DADR0	D/A	P	40000A0	8	8,16,32* ⁵ * ⁶
DADR1	D/A	P	40000A2	8	8,16* ⁵
DACR	D/A	P	40000A4	8	8,16,32
PACR	PORT	P	4000100	16	16
PBCR	PORT	P	4000102	16	16
PCCR	PORT	P	4000104	16	16
PDCR	PORT	P	4000106	16	16
PECR	PORT	P	4000108	16	16
PFCR	PORT	P	400010A	16	16
PGCR	PORT	P	400010C	16	16
PHCR	PORT	P	400010E	16	16
PJCR	PORT	P	4000110	16	16
PKCR	PORT	P	4000112	16	16
PLCR	PORT	P	4000114	16	16
SCPCR	PORT	P	4000116	16	16
PADR	PORT	P	4000120	8	8
PBDR	PORT	P	4000122	8	8
PCDR	PORT	P	4000124	8	8
PDDR	PORT	P	4000126	8	8
PEDR	PORT	P	4000128	8	8
PFDR	PORT	P	400012A	8	8
PGDR	PORT	P	400012C	8	8
PHDR	PORT	P	400012E	8	8
PJDR	PORT	P	4000130	8	8
PKDR	PORT	P	4000132	8	8
PLDR	PORT	P	4000134	8	8
SCPDR	PORT	P	4000136	8	8

Control Register	Module* ¹	Bus* ²	Address* ⁴	Size (Bits)	Access Size (Bits)* ³
SCSMR1	IrDA	P	4000140	8	8
SCBRR1	IrDA	P	4000142	8	8
SCSCR1	IrDA	P	4000144	8	8
SCFTDR1	IrDA	P	4000146	8	8
SCSSR1	IrDA	P	4000148	16	16
SCFRDR1	IrDA	P	400014A	8	8
SCFCR1	IrDA	P	400014C	8	8
SCFDR1	IrDA	P	400014E	16	16
SCSMR2	SCIF	P	4000150	8	8
SCBRR2	SCIF	P	4000152	8	8
SCSCR2	SCIF	P	4000154	8	8
SCFTDR2	SCIF	P	4000156	8	8
SCSSR2	SCIF	P	4000158	16	16
SCFRDR2	SCIF	P	400015A	8	8
SCFCR2	SCIF	P	400015C	8	8
SCFDR2	SCIF	P	400015E	16	16
SDIR	UDI	I	4000200	16	16

Notes: 1. Modules:

CCN: Cache controller UBC: User break controller
 CPG: Clock pulse generator BSC: Bus state controller
 RTC: Realtime clock INTC: Interrupt controller
 TMU: Timer unit SCI: Serial communication interface

2. Internal buses:

L: CPU, CCN, cache, TLB connected
 I: BSC, cache, DMAC, INTC, CPG, and UDI connected
 P: BSC and peripheral modules (RTC, TMU, SCI, SCIF, IrDA, A/D, D/A, DMAC, PORT, CMT) connected

- The access size shown is for control register access (read/write). An incorrect result will be obtained if a different size from that shown is used for access.
- To exclude area 1 control registers from address translation by the MMU, set the first 3 bits of the logical address to 101, to locate the registers in the P2 space.
- With 16-bit access, it is not possible to read data in two registers simultaneously.
- With 32-bit access, it is possible to read data in the register at [accessed address + 2] simultaneously.

B.2 Register Bits

Table B.2 Register Bits

Register	Bit 7	Bit 6	Bit 5	Bit 4	Bit 3	Bit 2	Bit 1	Bit 0	Module
SDMR	—	—	—	—					BSC
SCSMR	C/A	CHR	PE	O/E	STOP	MP	CKS1	CKS0	SCI
SCBRR									SCI
SCSCR	TIE	RIE	TE	RE	MPIE	TEIE	CKE1	CKE0	SCI
SCTDR									SCI
SCSSR	TDRE	RDRF	ORER	FER	PER	TEND	MPB	MPBT	SCI
SCRDR									SCI
SCSCMR	—	—	—	—	SDIR	SINV	—	SMIF	SCI
TOCR	—	—	—	—	—	—	—	TCOE	TMU
TSTR	—	—	—	—	—	STR2	STR1	STR0	TMU
TCOR0									TMU
TCNT0									TMU
TCR0	—	—	—	—	—	—	—	UNF	TMU
	—	—	UNIE	CKEG1	CKEG0	TPSC2	TPSC1	TPSC0	
TCOR1									TMU
TCNT1									TMU

Register	Bit 7	Bit 6	Bit 5	Bit 4	Bit 3	Bit 2	Bit 1	Bit 0	Module	
TCR1	—	—	—	—	—	—	—	UNF	TMU	
	—	—	UNIE	CKEG1	CKEG0	TPSC2	TPSC1	TPSC0		
TCOR2									TMU	
TCNT2									TMU	
TCR2	—	—	—	—	—	—	ICPF	UNF	TMU	
	ICPE1	ICPE0	UNIE	CKEG1	CKEG0	TPSC2	TPSC1	TPSC0		
TCPR2									TMU	
R64CNT	—	1 Hz	2 Hz	4 Hz	8 Hz	16 Hz	32 Hz	64 Hz	RTC	
RSECCNT	—	10 sec			1 sec				RTC	
RMINCNT	—	10 min			1 min				RTC	
RHRCNT	—	—	10 hours		1 hour				RTC	
RWKCNT	—	—	—	—	—	Day of week			RTC	
RDAYCNT	—	—	10 days			1 day				RTC
RMONCNT	—	—	—	10 months	1 month				RTC	
RYRCNT	10 years				1 year				RTC	
RSECAR	ENB	10 sec			1 sec				RTC	
RMINAR	ENB	10 min			1 min				RTC	
RWKAR	ENB	—	—	—	—	Day of week			RTC	
RHRAR	ENB	—	10 hours		1 hour				RTC	
RDAYAR	ENB	—	10 days			1 day				RTC
RMONAR	ENB	—	—	10 months	1 month				RTC	

Register	Bit 7	Bit 6	Bit 5	Bit 4	Bit 3	Bit 2	Bit 1	Bit 0	Module
RCR1	CF	—	—	CIE	AIE	—	—	AF	RTC
RCR2	PEF	PES2	PES1	PES0	RTCEN	ADJ	RESET	START	RTC
ICR0	NML	—	—	—	—	—	—	NMIE	INTC
	—	—	—	—	—	—	—	—	
IPRA	TMU0				TMU1				INTC
	TMU2				RTC				
IPRB	WDT				REF				INTC
	SCI				—	—	—	—	
BCR1	PULA	PULD	HIZMEM	HIZCNT	ENDIAN	A0BST1	A0BST0	A5BST1	BSC
	A5BST0	A6BST1	A6BST0	DRAMTP2	DRAMTP1	DRAMTP0	A5PCM	A6PCM	
BCR2	—	—	A6SZ1	A6SZ0	A5SZ1	A5SZ0	A4SZ1	A4SZ0	BSC
	A3SZ1	A3SZ0	A2SZ1	A2SZ0	—	—	—	—	
WCR1	WAITSEL	—	A6IW1	A6IW0	A5IW1	A5IW0	A4IW1	A4IW0	BSC
	A3IW1	A3IW0	A2IW1	A2IW0	—	—	A0IW1	A0IW0	
WCR2	A6W2	A6W1	A6W0	A5W2	A5W1	A5W0	A4W2	A4W1	BSC
	A4W0	A3W1	A3W0	A2W1	A2W0	A0W2	A0W1	A0W0	
MCR	TPC1	TPC0	RCD1	RCD0	TRWL1	TRWL0	TRAS1	TRAS0	BSC
	RASD	AMX3	AMX2	AMX1	AMX0	RFSH	RMODE	—	
PCR	A6W3	A5W3	—	—	A5TED2	A6TED2	A5TEH2	A6TEH2	BSC
	A5TED1	A5TED0	A6TED1	A6TED0	A5TEH1	A5TEH0	A6TEH1	A6TEH0	
RTCSR	—	—	—	—	—	—	—	—	BSC
	CMF	CMIE	CKS2	CKS1	CKS0	OVF	OVIE	LMTS	
RTCNT	—	—	—	—	—	—	—	—	BSC
	—	—	—	—	—	—	—	—	
RTCOR	—	—	—	—	—	—	—	—	BSC
	—	—	—	—	—	—	—	—	

Register	Bit 7	Bit 6	Bit 5	Bit 4	Bit 3	Bit 2	Bit 1	Bit 0	Module
RFCR	—	—	—	—	—	—	—	—	BSC
FRQCR	STC2	IFC2	PFC2	—	—	—	SLPFRQ	CKOEN	CPG
	PLLEN	PSTBY	STC1	STC0	IFC1	IFC0	PFC1	PFC0	
STBCR	STBY	—	—	STBXTL	—	MSTP2	MSTP1	MSTP0	CPG
STBCR2	MSTP9	MDCHG	MSTP8	MSTP7	MSTP6	MSTP5	MSTP4	MSTP3	CPG
WTCNT									CPG
WTCR	TME	WT/IT	RSTS	WOVF	IOVF	CKS2	CKS1	CKS0	CPG
BDRB									UBC
BDMRB									UBC
BRDR	—	—	—	—	—	—	—	—	UBC
	—	—	BASMA	BASMB	—	—	—	—	
	SCMFCA	SCMFCB	SCMFDA	SCMFDB	PCTE	PCBA	—	—	
	DBEB	PCBB	—	—	SEQ	—	—	ETBE	
BARB									UBC
BAMRB	—	—	—	—	—	BASM	BAM	BAM	UBC
BBRB	—	—	—	—	—	—	—	—	UBC
	CDB1	CDB0	IDB1	IDB0	RWB1	RWB0	SZB1	SZB0	
BARA									UBC

Register	Bit 7	Bit 6	Bit 5	Bit 4	Bit 3	Bit 2	Bit 1	Bit 0	Module
BAMRA									UBC
BBRA	—	—	—	—	—	—	—	—	UBC
	CDA1	CDA0	IDA1	IDA0	RWA1	RWA0	SZA1	SZA0	
BETR	—	—	—	—					UBC
BRSR	SVF	PID2	PID1	PID0	BSA27	BSA26	BSA25	BSA24	UBC
	BSA23	BSA22	BSA21	BSA20	BSA19	BSA18	BSA17	BSA16	
	BSA15	BSA14	BSA13	BSA12	BSA11	BSA10	BSA9	BSA8	
	BSA7	BSA6	BSA5	BSA4	BSA3	BSA2	BSA1	BSA0	
BRDR	DVF	—	—	—	BDA27	BDA26	BDA25	BDA24	UBC
	BDA23	BDA22	BDA21	BDA20	BDA19	BDA18	BDA17	BDA16	
	BDA15	BDA14	BDA13	BDA12	BDA11	BDA10	BDA9	BDA8	
	BDA7	BDA6	BDA5	BDA4	BDA3	BDA2	BDA1	BDA0	
TRA	—	—	—	—	—	—	—	—	CCN
	—	—	—	—	—	—	—	—	
	—	—	—	—	—	—	—	—	
							—	—	
EXPEVT	—	—	—	—	—	—	—	—	CCN
	—	—	—	—	—	—	—	—	
	—	—	—	—					
INTEVT	—	—	—	—	—	—	—	—	CCN
	—	—	—	—	—	—	—	—	
	—	—	—	—					
MMUCR	—	—	—	—	—	—	—	—	CCN
	—	—	—	—	—	—	—	—	
	—	—	—	—	—	—	—	SV	
	—	—	RC	RC	—	TF	IX	AT	

Register	Bit 7	Bit 6	Bit 5	Bit 4	Bit 3	Bit 2	Bit 1	Bit 0	Module
BASRA									UBC
BASRB									UBC
CCR	—	—	—	—	—	—	—	—	CCN
	—	—	—	—	—	—	—	—	
	—	—	—	—	—	—	—	—	
	—	—	0	0	CF	CB	WT	CE	
CDR2									CCN
							W3LOAD	W3LOCK	
							W2LOAD	W2LOCK	
PTEH									CCN
							—	—	
PTEL									CCN
							—	V	
	—	PR	PR	SZ	C	D	SH	—	
TTB									CCN
TEA									CCN
INTEVT2									INTC

Register	Bit 7	Bit 6	Bit 5	Bit 4	Bit 3	Bit 2	Bit 1	Bit 0	Module
IRR0									INTC
	PINT0R	PINT1R	IRQ5R	IRQ4R	IRQ3R	IRQ2R	IRQ1R	IRQ0R	
IRR1									INTC
	TXI1R	BRI1R	RXI1R	ERI1R	DEI3R	DEI2R	DEI1R	DEI0R	
IRR2									INTC
	—	—	—	ADIR	TXI2R	BRI2R	RXI2R	ERI2R	
ICR1	MAI	IRQLVL	BLMSK	—	IRQ51S	IRQ50S	IRQ41S	IRQ40S	INTC
	IRQ31S	IRQ30S	IRQ21S	IRQ20S	IRQ11S	IRQ10S	IRQ01S	IRQ00S	
ICR2	PINT15S	PINT14S	PINT13S	PINT12S	PINT11S	PINT10S	PINT9S	PINT8S	INTC
	PINT7S	PINT6S	PINT5S	PINT4S	PINT3S	PINT2S	PINT1S	PINT0S	
PINTER	PINT15E	PINT14E	PINT13E	PINT12E	PINT11E	PINT10E	PINT9E	PINT8E	INTC
	PINT7E	PINT6E	PINT5E	PINT4E	PINT3E	PINT2E	PINT1E	PINT0E	
IPRC	IRQ3 level				IRQ2 level				INTC
	IRQ1 level				IRQ0 level				
IPRD	PINT0 to 7 level				PINT8 to 15 level				INTC
	IRQ5 level				IRQ4 level				
IPRE	DMAC level				IrDA level				INTC
	SCIF level				A/D level				
SAR0									DMAC
DAR0									DMAC
DMATCR0	—	—	—	—	—	—	—	—	DMAC

Register	Bit 7	Bit 6	Bit 5	Bit 4	Bit 3	Bit 2	Bit 1	Bit 0	Module
CHCR0	—	—	—	—	—	—	—	—	DMAC
	—	—	—	—	—	RL	AM	AL	
	DM1	DM0	SM1	SM0	RS3	RS2	RS1	RS0	
	—	DS	TM	TS1	TS0	IE	TE	DE	
SAR1									DMAC
DAR1									DMAC
DMATCR1	—	—	—	—	—	—	—	—	DMAC
CHCR1	—	—	—	—	—	—	—	—	DMAC
	—	—	—	—	—	RL	AM	AL	
	DM1	DM0	SM1	SM0	RS3	RS2	RS1	RS0	
	—	DS	TM	TS1	TS0	IE	TE	DE	
SAR2									DMAC
DAR2									DMAC
DMATCR2	—	—	—	—	—	—	—	—	DMAC

Register	Bit 7	Bit 6	Bit 5	Bit 4	Bit 3	Bit 2	Bit 1	Bit 0	Module
CHCR2	—	—	—	—	—	—	—	—	DMAC
	—	—	—	—	RO	—	—	—	
	DM1	DM0	SM1	SM0	RS3	RS2	RS1	RS0	
	—	—	TM	TS1	TS0	IE	TE	DE	
SAR3									DMAC
DAR3									DMAC
DMATCR3	—	—	—	—	—	—	—	—	DMAC
CHCR3	—	—	—	—	—	—	—	—	DMAC
	—	—	—	DI	—	—	—	—	
	DM1	DM0	SM1	SM0	RS3	RS2	RS1	RS0	
	—	—	TM	TS1	TS0	IE	TE	DE	
DMAOR	—	—	—	—	—	—	PR1	PR0	DMAC
	—	—	—	—	—	AE	NMIF	DME	
CMSTR	—	—	—	—	—	—	—	—	CMT
	—	—	—	—	—	—	—	STR	
CMCSR	—	—	—	—	—	—	—	—	CMT
	CMF	—	—	—	—	—	CKS1	CKS0	
CMCNT									CMT
CMCOR									CMT
ADDRAH	AD9	AD8	AD7	AD6	AD5	AD4	AD3	AD2	A/DC
ADDRAL	AD1	AD0	—	—	—	—	—	—	A/DC

Register	Bit 7	Bit 6	Bit 5	Bit 4	Bit 3	Bit 2	Bit 1	Bit 0	Module
ADDRBH	AD9	AD8	AD7	AD6	AD5	AD4	AD3	AD2	A/DC
ADDRBL	AD1	AD0	—	—	—	—	—	—	A/DC
ADDRCH	AD9	AD8	AD7	AD6	AD5	AD4	AD3	AD2	A/DC
ADDRCL	AD1	AD0	—	—	—	—	—	—	A/DC
ADDRDH	AD9	AD8	AD7	AD6	AD5	AD4	AD3	AD2	A/DC
ADDRDL	AD1	AD0	—	—	—	—	—	—	A/DC
ADCSR	ADF	ADE	ADST	MULT1	CKS	CH2	CH1	CH0	A/DC
ADCR	TRGE1	TRGE2	SCN	RESVD1	RESVD2	—	—	—	A/DC
DADR0									D/AC
DADR1									D/AC
DACR	DAOE1	DAOE0	DAE	—	—	—	—	—	D/AC
PACR	PA7M D1	PA7M D0	PA6M D1	PA6M D0	PA5M D1	PA5M D0	PA4M D1	PA4M D0	PORT
	PA3M D1	PA3M D0	PA2M D1	PA2M D0	PA1M D1	PA1M D0	PA0M D1	PA0M D0	
PBCR	PB7M D1	PB7M D0	PB6M D1	PB6M D0	PB5M D1	PB5M D0	PB4M D1	PB4M D0	PORT
	PB3M D1	PB3M D0	PB2M D1	PB2M D0	PB1M D1	PB1M D0	PB0M D1	PB0M D0	
PCDR	PC7M D1	PC7M D0	PC6M D1	PC6M D0	PC5M D1	PC5M D0	PC4M D1	PC4M D0	PORT
	PC3M D1	PC3M D0	PC2M D1	PC2M D0	PC1M D1	PC1M D0	PC0M D1	PC0M D0	
PDCR	PD7M D1	PD7M D0	PD6M D1	PD6M D0	PD5M D1	PD5M D0	PD4M D1	PD4M D0	PORT
	PD3M D1	PD3M D0	PD2M D1	PD2M D0	PD1M D1	PD1M D0	PD0M D1	PD0M D0	
PECR	PE7M D1	PE7M D0	PE6M D1	PE6M D0	PE5M D1	PE5M D0	PE4M D1	PE4M D0	PORT
	PE3M D1	PE3M D0	PE2M D1	PE2M D0	PE1M D1	PE1M D0	PE0M D1	PE0M D0	
PFCR	PF7M D1	PF7M D0	PF6M D1	PF6M D0	PF5M D1	PF5M D0	PF4M D1	PF4M D0	PORT
	PF3M D1	PF3M D0	PF2M D1	PF2M D0	PF1M D1	PF1M D0	PF0M D1	PF0M D0	

Register	Bit 7	Bit 6	Bit 5	Bit 4	Bit 3	Bit 2	Bit 1	Bit 0	Module
PGCR	PG7M D1	PG7M D0	PG6M D1	PG6M D0	PG5M D1	PG5M D0	PG4M D1	PG4M D0	PORT
	PG3M D1	PG3M D0	PG2M D1	PG2M D0	PG1M D1	PG1M D0	PG0M D1	PG0M D0	
PHCR	PH7M D1	PH7M D0	PH6M D1	PH6M D0	PH5M D1	PH5M D0	PH4M D1	PH4M D0	PORT
	PH3M D1	PH3M D0	PH2M D1	PH2M D0	PH1M D1	PH1M D0	PH0M D1	PH0M D0	
PJCR	PJ7M D1	PJ7M D0	PJ6M D1	PJ6M D0	PJ5M D1	PJ5M D0	PJ4M D1	PJ4M D0	PORT
	PJ3M D1	PJ3M D0	PJ2M D1	PJ2M D0	PJ1M D1	PJ1M D0	PJ0M D1	PJ0M D0	
PKCR	PK7M D1	PK7M D0	PK6M D1	PK6M D0	PK5M D1	PK5M D0	PK4M D1	PK4M D0	PORT
	PK3M D1	PK3M D0	PK2M D1	PK2M D0	PK1M D1	PK1M D0	PK0M D1	PK0M D0	
PLCR	PL7M D1	PL7M D0	PL6M D1	PL6M D0	PL5M D1	PL5M D0	PL4M D1	PL4M D0	PORT
	PL3M D1	PL3M D0	PL2M D1	PL2M D0	PL1M D1	PL1M D0	PL0M D1	PL0M D0	
SCPCR	SCP7M D1	SCP7M D0	SCP6M D1	SCP6M D0	SCP5M D1	SCP5M D0	SCP4M D1	SCP4M D0	PORT
	SCP3M D1	SCP3M D0	SCP2M D1	SCP2M D0	SCP1M D1	SCP1M D0	SCP0M D1	SCP0M D0	
PADR	PA7DT	PA6DT	PA5DT	PA4DT	PA3DT	PA2DT	PA1DT	PA0DT	PORT
PBDR	PB7DT	PB6DT	PB5DT	PB4DT	PB3DT	PB2DT	PB1DT	PB0DT	PORT
PCDR	PC7DT	PC6DT	PC5DT	PC4DT	PC3DT	PC2DT	PC1DT	PC0DT	PORT
PDDR	PD7DT	PD6DT	PD5DT	PD4DT	PD3DT	PD2DT	PD1DT	PD0DT	PORT
PEDR	PE7DT	PE6DT	PE5DT	PE4DT	PE3DT	PE2DT	PE1DT	PE0DT	PORT
PFDR	PF7DT	PF6DT	PF5DT	PF4DT	PF3DT	PF2DT	PF1DT	PF0DT	PORT
PGDR	PG7DT	PG6DT	PG5DT	PG4DT	PG3DT	PG2DT	PG1DT	PG0DT	PORT
PHDR	PH7DT	PH6DT	PH5DT	PH4DT	PH3DT	PH2DT	PH1DT	PH0DT	PORT
PJDR	PJ7DT	PJ6DT	PJ5DT	PJ4DT	PJ3DT	PJ2DT	PJ1DT	PJ0DT	PORT
PKDR	PK7DT	PK6DT	PK5DT	PK4DT	PK3DT	PK2DT	PK1DT	PK0DT	PORT
PLDR	PL7DT	PL6DT	PL5DT	PL4DT	PL3DT	PL2DT	PL1DT	PL0DT	PORT
SCPDR	SCP7DT	SCP6DT	SCP5DT	SCP4DT	SCP3DT	SCP2DT	SCP1DT	SCP0DT	PORT

Register	BIT7	BIT6	BIT5	BIT4	BIT3	BIT2	BIT1	BIT0	Module
SDIR	TI3	TI2	TI1	TI0	—	—	—	—	UDI
	—	—	—	—	—	—	—	—	
SCSMR1	IRM0D	ICK3	ICK2	ICK1	ICK0	PSEL	CKS1	CKS0	IrDA
SCBRR1									IrDA
SCSCR1	TIE	RIE	TE	RE	—	—	CKE1	CKE0	IrDA
SCFTDR1									IrDA
SCSSR1	PER3	PER2	PER1	PER0	FER3	FER2	FER1	FER0	IrDA
	ER	TEND	TDFE	BRK	FER	PER	RDF	DR	
SCFRDR1									IrDA
SCFCR1	RTRG1	RTRG0	TTRG1	TTRG0	MCE	TFRST	RFRST	LOOP	IrDA
SCFDR1	—	—	—	T4	T3	T2	T1	T0	IrDA
	—	—	—	R4	R3	R2	R1	R0	
SCSMR2	—	CHR	PE	O/E	STOP	—	CKS1	CKS0	SCIF
SCBRR2									SCIF
SCSCR2	TIE	RIE	TE	RE	—	—	CKE1	CKE0	SCIF
SCFTDR2									SCIF
SCSSR2	PER3	PER2	PER1	PER0	FER3	FER2	FER1	FER0	SCIF
	ER	TEND	TDFE	BRK	FER	PER	RDF	DR	
SCFRDR2									SCIF
SCFCR2	RTRG1	RTRG0	TTRG1	TTRG0	MCE	TFRST	RFRST	LOOP	SCIF
SCFDR2	—	—	—	T4	T3	T2	T1	T0	SCIF
	—	—	—	R4	R3	R2	R1	R0	

Legend

MMU: Memory management unit
 UBC: User break controller
 CPG: Clock pulse generator
 BSC: Bus state controller
 RTC: Realtime clock
 INTC: Interrupt controller
 TMU: Timer unit
 SC1: Serial communication interface controller
 IrDA: Serial communication interface with IrDA
 SCIF: Serial communication interface with FIFO
 CCN: Cache controller
 DMAC: Direct memory access controller
 ADC: Analog to Digital converter
 DAC: Digital to Analog converter
 PORT: Port controller
 UDI: User debugging interface

Appendix C Product Lineup

Table C.1 SH7709S Models

Abbr.	Power Supply Voltage		Operating Frequency	Model Marking	Package
	I/O	Internal			
SH7709S	3.3±0.3 V	2.0±0.15 V	200 MHz	HD6417709SHF200B	208-pin plastic HQFP (FP-208E)
		1.9±0.15 V	167 MHz	HD6417709SF167B	208-pin plastic LQFP (FP-208C)
				HD6417709SBP167B	240-pin CSP (BP-240A)
		1.8+0.25 V 1.8–0.15 V	133 MHz	HD6417709SF133B	208-pin plastic LQFP (FP-208C)
				HD6417709SBP133B	240-pin CSP (BP-240A)
		1.7+0.25 V 1.7–0.15 V	100 MHz	HD6417709SF100B	208-pin plastic LQFP (FP-208C)
				HD6417709SBP100B	240-pin CSP (BP-240A)

Appendix D Package Dimensions

Figures D.1 to D.3 show the SH7709S package dimensions.

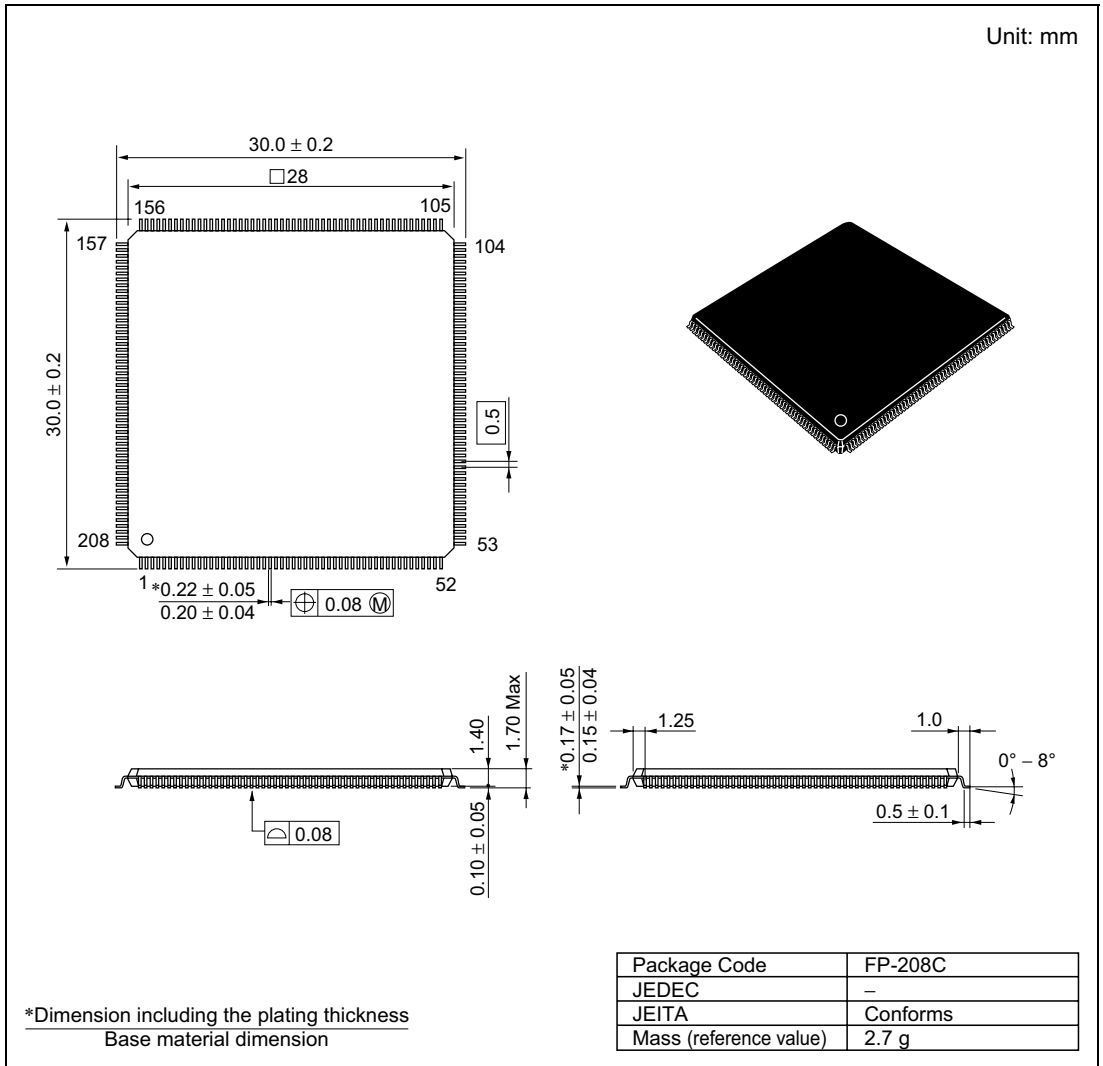
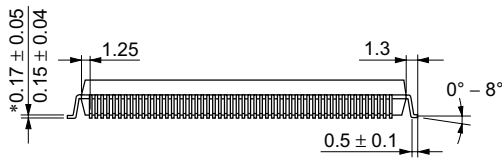
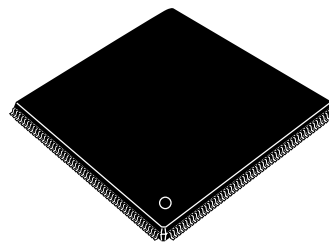
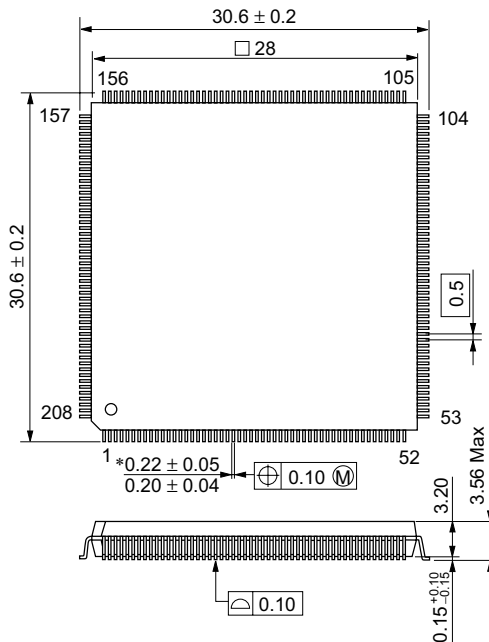

Figure D.1 Package Dimensions (FP-208C)

Unit: mm



*Dimension including the plating thickness
Base material dimension

Package Code	FP-208E
JEDEC	-
JEITA	Conforms
Mass (reference value)	5.3 g

Figure D.2 Package Dimensions (FP-208E)

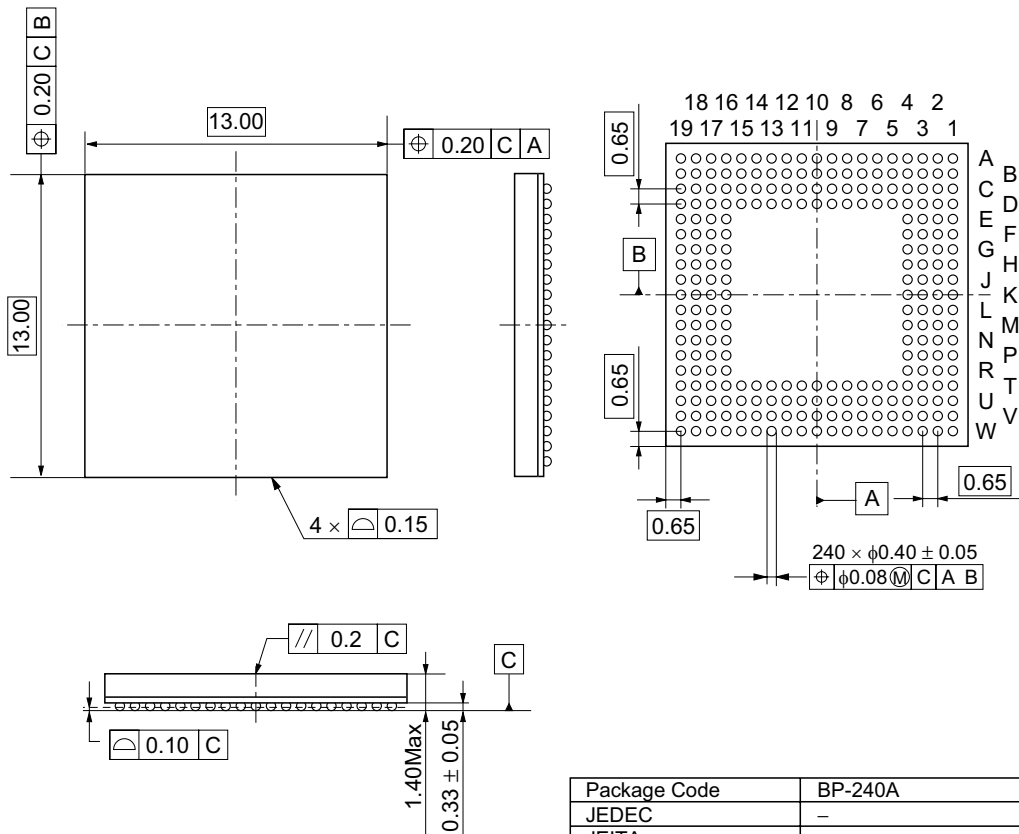
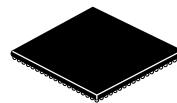

Package Code	BP-240A
JEDEC	-
JEITA	-
Mass (reference value)	0.4 g

Figure D.3 Package Dimensions (BP-240A)

SH7709S Group Hardware Manual

Publication Date: 1st Edition, September 2001
Rev.5.00, September 18, 2003

Published by: Sales Strategic Planning Div.
Renesas Technology Corp.

Edited by: Technical Documentation & Information Department
Renesas Kodaira Semiconductor Co., Ltd.

Renesas Technology Corp. Sales Strategic Planning Div. Nippon Bldg., 2-6-2, Ohte-machi, Chiyoda-ku, Tokyo 100-0004, Japan



RENESAS SALES OFFICES

<http://www.renesas.com>

Renesas Technology America, Inc.

450 Holger Way, San Jose, CA 95134-1368, U.S.A
Tel: <1> (408) 382-7500 Fax: <1> (408) 382-7501

Renesas Technology Europe Limited.

Dukes Meadow, Millboard Road, Bourne End, Buckinghamshire, SL8 5FH, United Kingdom
Tel: <44> (1628) 585 100, Fax: <44> (1628) 585 900

Renesas Technology Europe GmbH

Dornacher Str. 3, D-85622 Feldkirchen, Germany
Tel: <49> (89) 380 70 0, Fax: <49> (89) 929 30 11

Renesas Technology Hong Kong Ltd.

7/F., North Tower, World Finance Centre, Harbour City, Canton Road, Hong Kong
Tel: <852> 2265-6688, Fax: <852> 2375-6836

Renesas Technology Taiwan Co., Ltd.

FL 10, #99, Fu-Hsing N. Rd., Taipei, Taiwan
Tel: <886> (2) 2715-2888, Fax: <886> (2) 2713-2999

Renesas Technology (Shanghai) Co., Ltd.

26/F., Ruijin Building, No.205 Maoming Road (S), Shanghai 200020, China
Tel: <86> (21) 6472-1001, Fax: <86> (21) 6415-2952

Renesas Technology Singapore Pte. Ltd.

1, Harbour Front Avenue, #06-10, Keppel Bay Tower, Singapore 098632
Tel: <65> 6213-0200, Fax: <65> 6278-8001

SH7709S Group Hardware Manual



Renesas Electronics Corporation

1753, Shimonumabe, Nakahara-ku, Kawasaki-shi, Kanagawa 211-8668 Japan

REJ09B0081-05000