

CATALOG LISTING LDVS-5 [1] [2] [3] [4] [5]

1 NUMBER OF PLUNGER

CODE	NUMBER OF PLUNGER
2	2
3	3
4	4

2 TYPE OF ACTUATOR

CODE	TYPE OF PLUNGER
0	BEVEL
1	ROLLER

3 LOCATION OF CONDUIT HOLES, FURNISHED

CODE	LOCATION OF CONDUIT HOLES	CONDUIT PARTS
2	SIDE SURFACE OF HOUSING (2)	ATTACHED: 1 PLUG
4	MOUNTING SURFACE (2) AND SIDE SURFACE OF HOUSING (2)	ASSEMBLED: 2 O-RINGS (G30) 2 EACH PLUGS AND SEALS IN MOUNTING SURFACE 2 PLUGS IN SIDE SURFACE OF HOUSING

4 SCRAPER MATERIAL

CODE	MATERIAL
S	NITRILE RUBBER
V	FLUORINE RUBBER

5 CONTACT MATERIAL AND ELECTRICAL RATINGS
(STANDARD AND IEC ELECTRICAL RATINGS ARE BOTH INDICATED ON THE SWITCH BODY.)

CODE	CONTACT MATERIAL	ELECTRICAL RATING	EN60947-5-1, IEC 60947-5-1
~	SILVER	Y15 5A-AC250V	Y226 1.5A-AC250V AC-15 0.5A-DC 30V DC-12
K	GOLD ALLOY	Y93 0.1A-AC125V 0.1A-DC 30V	Y93 0.1A-AC125 V AC-12 0.1A-DC 30 V DC-12

LDVS-5*[0]***
(BEVEL PLUNGER)

CHARACTERISTICS	
OPERATING FORCE	14.7N max.
RELEASE FORCE	3.0N min.
PRETRAVEL	1.5 max.
MOVEMENT DIFFERENTIAL	0.2 max.
OVERTRAVEL	SEE SWITCH SPECIFICATIONS

NUMBER OF PLUNGER	L
2	58
3	70
4	82

- NOTES
- HOUSING AND COVER ARE MADE OF ALUMINUM ALLOY FINISHED WITH GRAY HAMMER TONE PAINT.
 - WHEN PIPING, REMOVE SEALING PLUG ASSEMBLED IN CONDUIT.
 - WHEN USING WITH MOUNTING SURFACE UPWARD, REMOVE SEALING PLUG TO PREVENT COOLANT FROM STAYING IN CONCAVITY.
 - USE LEAD WIRES HAVING 0.5 TO 2.5mm² CROSS SECTIONAL AREA WITH RING OR SPADE TYPE INSULATED CRIMP TERMINAL FOR M3 SCREW. THE WIDTH OF TERMINAL SHALL BE LESS THAN 7.5.
 - DO NOT WIRE MORE THAN 2 WIRES TO EACH TERMINAL WITHOUT CRIMP TERMINAL IN CASE OF MULTIPLE WIRES. USE INSULATED RING TYPE CRIMP TERMINAL FOR M3 SCREW (WIDTH OF TERMINAL TIP SHALL BE 7.5 MAX).
 - TERMINAL IDENTIFICATIONS AND SWITCH ARE MARKED ON TERMINAL BLOCKS NUMBERS.
 - DOG WIDTH SHALL BE MORE THAN 8.
 - PLUNGER SHOULD CONTACT WITH MATING DOG WITH ITS TOTAL WIDTH (REFER TO FIG 1).

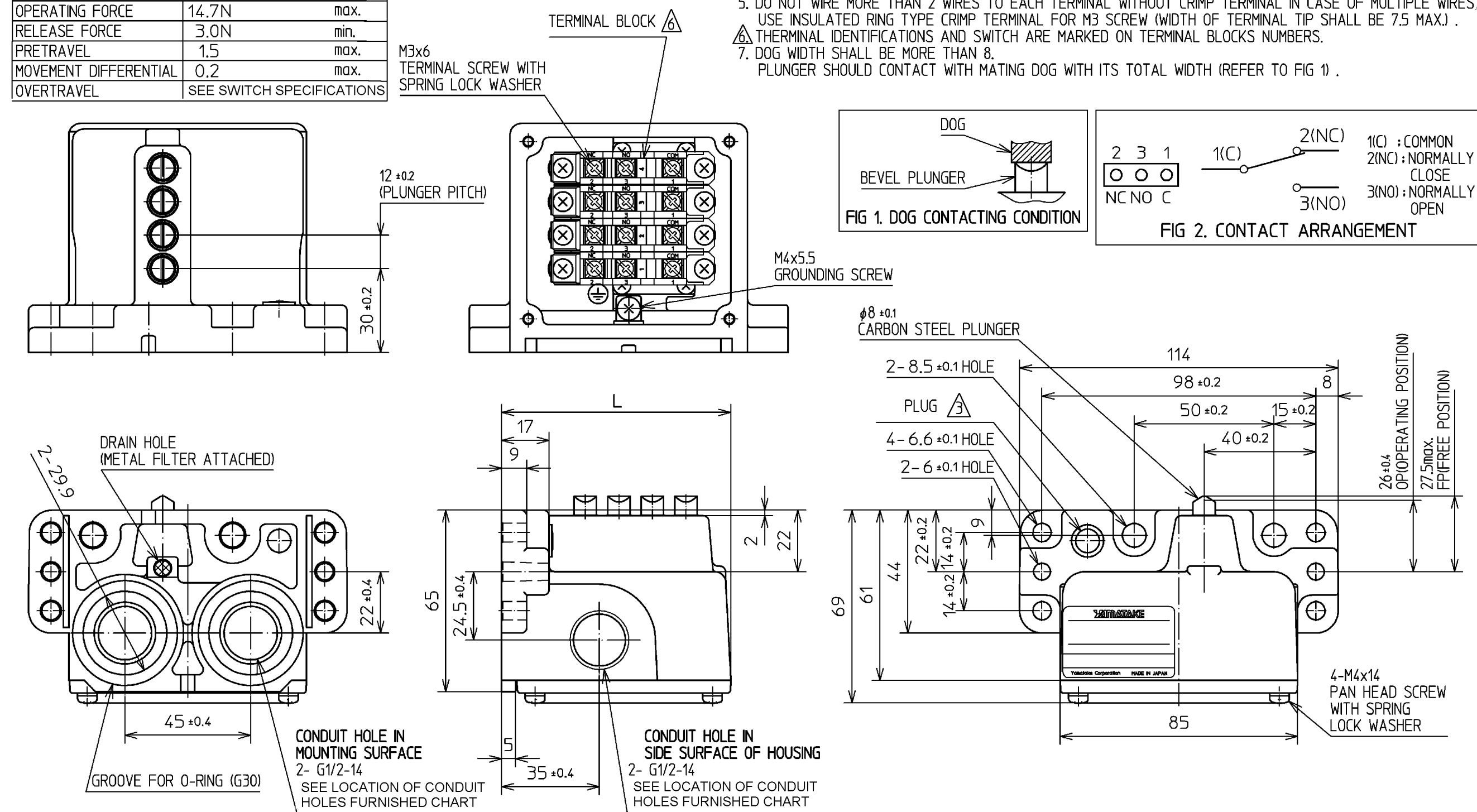

TOLERANCE UNLESS NOTED: +/- 0.4

PRECAUTIONS

- MOUNTING**
 - TIGHTEN EACH PORTION OF LIMIT SWITCH AT APPROPRIATE TORQUE SPECIFIED IN THIS SPECIFICATION.
 - OVER-TIGHTENING MAY DAMAGE THE SCREW THREADS OR OTHER PARTS.
 - LOOSE-TIGHTENING MAY CAUSE POOR SEALING OF SWITCH AND DECREASE IN VARIOUS PERFORMANCE.
 - DO NOT LEAVE OR USE THE SWITCH WITH COVER AND CONDUIT LEFT OPEN.
 - INGRESS OF WATER OR DUST MAY CAUSE OPERATION FAILURE.
 - DO NOT USE SILICONE RUBBER INSULATED CABLE, SILICONE ADHESIVES OR SILICONE-CONTAINED GREASE. THEY MAY CAUSE ELECTRICAL CONTACT FAILURE.
- WIRING**
 - DO NOT PERFORM WIRING WHILE POWER IS ON IT MAY CAUSE ELECTRICAL SHOCK OR SUDDEN MACHINE START.
 - USE INSULATED CRIMP TERMINALS FOR WIRING, AND TAKE CARE THAT THE TERMINAL AND WIRE SHALL NOT TOUCH COVER FAILUER TO DO SO, MAY CAUSE DIFFICULTY IN COVER MOUNTING OR CAUSE EARTHING TROUBLE.
 - USE SEAL CONNECTOR (SEPARATE ORDER, PA1 SERIES) OR FLEXIBLE PIPE (PA3 SERIES) FOR CONDUIT TO GET SEALING PERFORMANCE NOT LESS THAN IP67 OR EQUIVALENT.
 - BE SURE TO MOUNT THE COVER AND CONDUIT TIGHTLY.
 - POOR MOUNTING MAY CAUSE INSULATION FAILURE DUE TO DECREASE IN SEALING PERFORMANCE. AS A RESULT, THE SWITCH WOULD NOT SATISFY ITS OPERATION PERFORMANCE.
- ADJUSTMENT**
 - DO NOT APPLY EXCESSIVE FORCE (MORE THAN 5 TIMES OF OPERATING FORCE) TO THE ACTUATOR BEYOND THE LIMIT OF ITS TRAVEL IT MAY BREAK THE SWITCH.
 - OVERTRAVEL MUST BE 70 TO 100% OF THE RATED VALUE.
 - SMALL OVERTRAVEL MAY CAUSE CHATTERING OF CONTACT OR CONTACT FAILURE BY VIBRATION OR SHOCK.

LDVS-5*[1]***
(ROLLER PLUNGER)

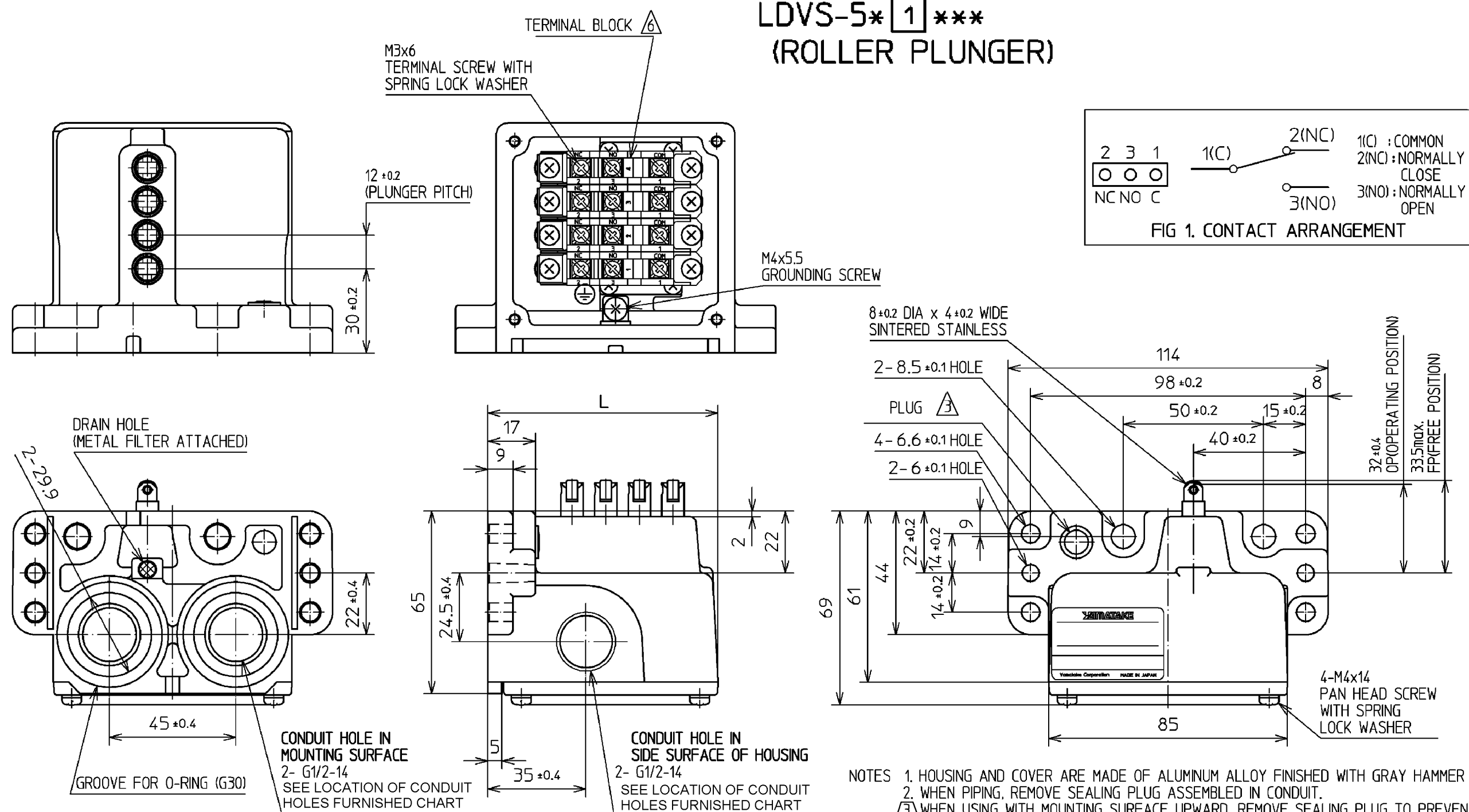
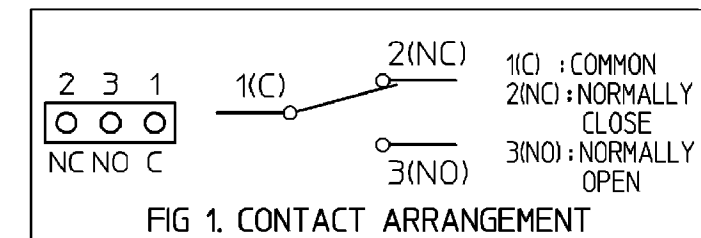

TOLERANCE UNLESS NOTED: +/- 0.4

- NOTES
- HOUSING AND COVER ARE MADE OF ALUMINUM ALLOY FINISHED WITH GRAY HAMMER TONE PAINT.
 - WHEN PIPING, REMOVE SEALING PLUG ASSEMBLED IN CONDUIT.
 - WHEN USING WITH MOUNTING SURFACE UPWARD, REMOVE SEALING PLUG TO PREVENT COOLANT FROM STAYING IN CONCAVITY.
 - USE LEAD WIRES HAVING 0.5 TO 2.5mm² CROSS SECTIONAL AREA WITH RING OR SPADE TYPE INSULATED CRIMP TERMINAL FOR M3 SCREW. THE WIDTH OF TERMINAL SHALL BE LESS THAN 7.5.
 - DO NOT WIRE MORE THAN 2 WIRES TO EACH TERMINAL WITHOUT CRIMP TERMINAL IN CASE OF MULTIPLE WIRES. USE INSULATED RING TYPE CRIMP TERMINAL FOR M3 SCREW (WIDTH OF TERMINAL TIP SHALL BE 7.5 MAX).
 - TERMINAL IDENTIFICATIONS AND SWITCH ARE MARKED ON TERMINAL BLOCKS NUMBERS.

CHARACTERISTICS	
OPERATING FORCE	14.7N max.
RELEASE FORCE	3.0N min.
PRETRAVEL	1.5 max.
MOVEMENT DIFFERENTIAL	0.2 max.
OVERTRAVEL	SEE SWITCH SPECIFICATIONS

NUMBER OF PLUNGER	L
2	58
3	70
4	82

SWITCH SPECIFICATIONS

- STANDARDS**
 - Conform to: JIS C 4508 IEC 60947-5-1
 - Approved by: EN60947-5-1(TUV)
- STRUCTURE**
 - Type of Contact: SPDT
 - Shape of Terminal: Silver (M3 pan head screw with lock washer)
 - Shape of Contact: Silver, Rivet, Gold Alloy, Cross point, IP67 (IEC 60529)
 - Protective Structure: Degree 3 (EN60947-5-1)
 - Environment pollution degree: Degree 3 (EN60947-5-1)
- ELECTRICAL CHARACTERISTICS**

(1) GENERAL PERFORMANCE

Portions to be measured	Insulation Resistance (500VDC megger)	Dielectric Strength (50-60Hz, for 1 minute)
Between unconnected terminals	100 MΩ min.	600 VAC
Between each terminal and non-live metal part	100 MΩ min.	1500 VAC
Between each terminal and ground	100 MΩ min.	1500 VAC

(2) PERFORMANCE PER EN60947-5-1 AND IEC 60947-5-1

 - Rated operational voltages: Silver Contacts: 250VAC, 30VDC; Gold Alloy Contacts: 125VAC, 15VDC
 - Rated frequency: 45-65Hz and "cc"
 - Rated insulation voltage (Ui): 250 VAC
 - Rated impulse withstand voltage (Uimp): 4000V
 - Conventional free air thermal current (Ith): Silver Contacts: 5A; Gold Alloy Contacts: 0.5A
 - Short circuit protective device: Fast acting fuse 10A (Bussmann ABC10 or equivalent), 100A (at resistive load), Category III (IEC 60204-1)
- MECHANICAL CHARACTERISTICS** (Value at 25° dog angle)
 - Actuator Strength, Withstand 5 times O.F. in the operating direction for 1 minute.
 - Terminal Strength, Withstand 0.6N·m tightening torque applied for 1 minute.
 - Shock: Silver Contacts: 600 m/s²; Gold Alloy Contacts: 400 m/s²
 - Misoperation of the contact shall be 1 ms max. in the free position and the total travel position.
 - Vibration: Peak-to-peak amplitude 15 mm. Vibration frequency 10 to 55 Hz for continuous 2 hours. Misoperation of the contact shall be 1 ms max. in the free position and the total travel position.
 - Allowable Operating Speed, 0.07 mm/s to 0.5 mm/s. The lowest speed, Unstable condition of the contact shall be 0.1s max. The highest speed, The actuator shall not damage.
 - Mechanical Operating Frequency, 120 cycles/minute max.
- LIFE**
 - Mechanical Life, 5000k cycles min. at "0.T." of 70 to 100% of the rating
 - Electrical Life, The conditions at operation frequency of 20 cycles a minute are satisfied.

Contact material	Condition	Operation cycle
Silver	5A-250 VAC	50K cycles min.
	3A-250 VDC	100K cycles min.
	0.2A-125 VDC	200K cycles min.
Gold Alloy	0.1A-125 VAC	200K cycles min.
- ENVIRONMENTAL CHARACTERISTICS**
 - Operating Temperature, -10 to +70 °C (at no freezing)
 - Operating Humidity, 98%RH max.
- MOUNTING**
 - Recommended Tightening Torque: For mounting the switch to panel: 6 to 8 N·m (M6 cap screw); For mounting the terminal to switch: 0.4 to 0.6 N·m (M3); For mounting the cover to housing: 1.3 to 1.7 N·m (M4)
 - For mounting the plug to conduit hole in mounting surface: 0.6-0.8 N·m (G1/2)
 - For mounting the plug to conduit hole in side surface: 0.2-0.5 N·m (G1/2)

DESIGN UNITS: MM	DRAWN	VKR	24FEB05
TOLERANCES UNLESS NOTED:	CHECK	AK	24MAR05
NO PLACE	1,000		
ONE PLACE	0.4		
TWO PLACE	0.15		
THREE PLACE	0.005		
FOUR PLACE	0.0005		
ANGLES	3		
THIRD ANGLE PROJECTION			

INTERPRET PER ASME Y14.5M-1994 OTHER HONEYWELL ENGINEERING STANDARDS MAY APPLY	SCALE	NTS
--	-------	-----

Honeywell	
MULTIPLE LIMIT SWITCH	
TITLE	LDVS-5 SERIES CHART 1
SIZE	D
TYPE	I
DRAWING NAME	LDVS-5 SERIES CHART 1
SCALE	NTS
SHEET	1 OF 1