

To our customers,

---

## Old Company Name in Catalogs and Other Documents

---

On April 1<sup>st</sup>, 2010, NEC Electronics Corporation merged with Renesas Technology Corporation, and Renesas Electronics Corporation took over all the business of both companies. Therefore, although the old company name remains in this document, it is a valid Renesas Electronics document. We appreciate your understanding.

Renesas Electronics website: <http://www.renesas.com>

April 1<sup>st</sup>, 2010  
Renesas Electronics Corporation

Issued by: Renesas Electronics Corporation (<http://www.renesas.com>)

Send any inquiries to <http://www.renesas.com/inquiry>.

## Notice

1. All information included in this document is current as of the date this document is issued. Such information, however, is subject to change without any prior notice. Before purchasing or using any Renesas Electronics products listed herein, please confirm the latest product information with a Renesas Electronics sales office. Also, please pay regular and careful attention to additional and different information to be disclosed by Renesas Electronics such as that disclosed through our website.
2. Renesas Electronics does not assume any liability for infringement of patents, copyrights, or other intellectual property rights of third parties by or arising from the use of Renesas Electronics products or technical information described in this document. No license, express, implied or otherwise, is granted hereby under any patents, copyrights or other intellectual property rights of Renesas Electronics or others.
3. You should not alter, modify, copy, or otherwise misappropriate any Renesas Electronics product, whether in whole or in part.
4. Descriptions of circuits, software and other related information in this document are provided only to illustrate the operation of semiconductor products and application examples. You are fully responsible for the incorporation of these circuits, software, and information in the design of your equipment. Renesas Electronics assumes no responsibility for any losses incurred by you or third parties arising from the use of these circuits, software, or information.
5. When exporting the products or technology described in this document, you should comply with the applicable export control laws and regulations and follow the procedures required by such laws and regulations. You should not use Renesas Electronics products or the technology described in this document for any purpose relating to military applications or use by the military, including but not limited to the development of weapons of mass destruction. Renesas Electronics products and technology may not be used for or incorporated into any products or systems whose manufacture, use, or sale is prohibited under any applicable domestic or foreign laws or regulations.
6. Renesas Electronics has used reasonable care in preparing the information included in this document, but Renesas Electronics does not warrant that such information is error free. Renesas Electronics assumes no liability whatsoever for any damages incurred by you resulting from errors in or omissions from the information included herein.
7. Renesas Electronics products are classified according to the following three quality grades: "Standard", "High Quality", and "Specific". The recommended applications for each Renesas Electronics product depends on the product's quality grade, as indicated below. You must check the quality grade of each Renesas Electronics product before using it in a particular application. You may not use any Renesas Electronics product for any application categorized as "Specific" without the prior written consent of Renesas Electronics. Further, you may not use any Renesas Electronics product for any application for which it is not intended without the prior written consent of Renesas Electronics. Renesas Electronics shall not be in any way liable for any damages or losses incurred by you or third parties arising from the use of any Renesas Electronics product for an application categorized as "Specific" or for which the product is not intended where you have failed to obtain the prior written consent of Renesas Electronics. The quality grade of each Renesas Electronics product is "Standard" unless otherwise expressly specified in a Renesas Electronics data sheets or data books, etc.

"Standard": Computers; office equipment; communications equipment; test and measurement equipment; audio and visual equipment; home electronic appliances; machine tools; personal electronic equipment; and industrial robots.

"High Quality": Transportation equipment (automobiles, trains, ships, etc.); traffic control systems; anti-disaster systems; anti-crime systems; safety equipment; and medical equipment not specifically designed for life support.

"Specific": Aircraft; aerospace equipment; submersible repeaters; nuclear reactor control systems; medical equipment or systems for life support (e.g. artificial life support devices or systems), surgical implantations, or healthcare intervention (e.g. excision, etc.), and any other applications or purposes that pose a direct threat to human life.

8. You should use the Renesas Electronics products described in this document within the range specified by Renesas Electronics, especially with respect to the maximum rating, operating supply voltage range, movement power voltage range, heat radiation characteristics, installation and other product characteristics. Renesas Electronics shall have no liability for malfunctions or damages arising out of the use of Renesas Electronics products beyond such specified ranges.
9. Although Renesas Electronics endeavors to improve the quality and reliability of its products, semiconductor products have specific characteristics such as the occurrence of failure at a certain rate and malfunctions under certain use conditions. Further, Renesas Electronics products are not subject to radiation resistance design. Please be sure to implement safety measures to guard them against the possibility of physical injury, and injury or damage caused by fire in the event of the failure of a Renesas Electronics product, such as safety design for hardware and software including but not limited to redundancy, fire control and malfunction prevention, appropriate treatment for aging degradation or any other appropriate measures. Because the evaluation of microcomputer software alone is very difficult, please evaluate the safety of the final products or system manufactured by you.
10. Please contact a Renesas Electronics sales office for details as to environmental matters such as the environmental compatibility of each Renesas Electronics product. Please use Renesas Electronics products in compliance with all applicable laws and regulations that regulate the inclusion or use of controlled substances, including without limitation, the EU RoHS Directive. Renesas Electronics assumes no liability for damages or losses occurring as a result of your noncompliance with applicable laws and regulations.
11. This document may not be reproduced or duplicated, in any form, in whole or in part, without prior written consent of Renesas Electronics.
12. Please contact a Renesas Electronics sales office if you have any questions regarding the information contained in this document or Renesas Electronics products, or if you have any other inquiries.

(Note 1) "Renesas Electronics" as used in this document means Renesas Electronics Corporation and also includes its majority-owned subsidiaries.

(Note 2) "Renesas Electronics product(s)" means any product developed or manufactured by or for Renesas Electronics.

The revision list can be viewed directly by clicking the title page. The revision list summarizes the locations of revisions and additions. Details should always be checked by referring to the relevant text.

# H8S/2218 Group, H8S/2212 Group

## Hardware Manual

### Renesas 16-Bit Single-Chip Microcomputer H8S Family/H8S/2200 Series

H8S/2218	HD64F2218 HD64F2218U HD6432217
H8S/2218C	HD64F2218CU HD64F2217CU
H8S/2212	HD64F2212 HD64F2212U HD64F2211 HD64F2211U HD6432211 HD6432210 HD6432210S
H8S/2212C	HD64F2212CU HD64F2211CU HD64F2210CU

## Notes regarding these materials

1. This document is provided for reference purposes only so that Renesas customers may select the appropriate Renesas products for their use. Renesas neither makes warranties or representations with respect to the accuracy or completeness of the information contained in this document nor grants any license to any intellectual property rights or any other rights of Renesas or any third party with respect to the information in this document.
2. Renesas shall have no liability for damages or infringement of any intellectual property or other rights arising out of the use of any information in this document, including, but not limited to, product data, diagrams, charts, programs, algorithms, and application circuit examples.
3. You should not use the products or the technology described in this document for the purpose of military applications such as the development of weapons of mass destruction or for the purpose of any other military use. When exporting the products or technology described herein, you should follow the applicable export control laws and regulations, and procedures required by such laws and regulations.
4. All information included in this document such as product data, diagrams, charts, programs, algorithms, and application circuit examples, is current as of the date this document is issued. Such information, however, is subject to change without any prior notice. Before purchasing or using any Renesas products listed in this document, please confirm the latest product information with a Renesas sales office. Also, please pay regular and careful attention to additional and different information to be disclosed by Renesas such as that disclosed through our website. (<http://www.renesas.com>)
5. Renesas has used reasonable care in compiling the information included in this document, but Renesas assumes no liability whatsoever for any damages incurred as a result of errors or omissions in the information included in this document.
6. When using or otherwise relying on the information in this document, you should evaluate the information in light of the total system before deciding about the applicability of such information to the intended application. Renesas makes no representations, warranties or guaranties regarding the suitability of its products for any particular application and specifically disclaims any liability arising out of the application and use of the information in this document or Renesas products.
7. With the exception of products specified by Renesas as suitable for automobile applications, Renesas products are not designed, manufactured or tested for applications or otherwise in systems the failure or malfunction of which may cause a direct threat to human life or create a risk of human injury or which require especially high quality and reliability such as safety systems, or equipment or systems for transportation and traffic, healthcare, combustion control, aerospace and aeronautics, nuclear power, or undersea communication transmission. If you are considering the use of our products for such purposes, please contact a Renesas sales office beforehand. Renesas shall have no liability for damages arising out of the uses set forth above.
8. Notwithstanding the preceding paragraph, you should not use Renesas products for the purposes listed below:
  - (1) artificial life support devices or systems
  - (2) surgical implantations
  - (3) healthcare intervention (e.g., excision, administration of medication, etc.)
  - (4) any other purposes that pose a direct threat to human lifeRenesas shall have no liability for damages arising out of the uses set forth in the above and purchasers who elect to use Renesas products in any of the foregoing applications shall indemnify and hold harmless Renesas Technology Corp., its affiliated companies and their officers, directors, and employees against any and all damages arising out of such applications.
9. You should use the products described herein within the range specified by Renesas, especially with respect to the maximum rating, operating supply voltage range, movement power voltage range, heat radiation characteristics, installation and other product characteristics. Renesas shall have no liability for malfunctions or damages arising out of the use of Renesas products beyond such specified ranges.
10. Although Renesas endeavors to improve the quality and reliability of its products, IC products have specific characteristics such as the occurrence of failure at a certain rate and malfunctions under certain use conditions. Please be sure to implement safety measures to guard against the possibility of physical injury, and injury or damage caused by fire in the event of the failure of a Renesas product, such as safety design for hardware and software including but not limited to redundancy, fire control and malfunction prevention, appropriate treatment for aging degradation or any other applicable measures. Among others, since the evaluation of microcomputer software alone is very difficult, please evaluate the safety of the final products or system manufactured by you.
11. In case Renesas products listed in this document are detached from the products to which the Renesas products are attached or affixed, the risk of accident such as swallowing by infants and small children is very high. You should implement safety measures so that Renesas products may not be easily detached from your products. Renesas shall have no liability for damages arising out of such detachment.
12. This document may not be reproduced or duplicated, in any form, in whole or in part, without prior written approval from Renesas.
13. Please contact a Renesas sales office if you have any questions regarding the information contained in this document, Renesas semiconductor products, or if you have any other inquiries.

# General Precautions in the Handling of MPU/MCU Products

The following usage notes are applicable to all MPU/MCU products from Renesas. For detailed usage notes on the products covered by this manual, refer to the relevant sections of the manual. If the descriptions under General Precautions in the Handling of MPU/MCU Products and in the body of the manual differ from each other, the description in the body of the manual takes precedence.

## 1. Handling of Unused Pins

Handle unused pins in accord with the directions given under Handling of Unused Pins in the manual.

- The input pins of CMOS products are generally in the high-impedance state. In operation with an unused pin in the open-circuit state, extra electromagnetic noise is induced in the vicinity of LSI, an associated shoot-through current flows internally, and malfunctions may occur due to the false recognition of the pin state as an input signal. Unused pins should be handled as described under Handling of Unused Pins in the manual.

## 2. Processing at Power-on

The state of the product is undefined at the moment when power is supplied.

- The states of internal circuits in the LSI are indeterminate and the states of register settings and pins are undefined at the moment when power is supplied.

In a finished product where the reset signal is applied to the external reset pin, the states of pins are not guaranteed from the moment when power is supplied until the reset process is completed.

In a similar way, the states of pins in a product that is reset by an on-chip power-on reset function are not guaranteed from the moment when power is supplied until the power reaches the level at which resetting has been specified.

## 3. Prohibition of Access to Reserved Addresses

Access to reserved addresses is prohibited.

- The reserved addresses are provided for the possible future expansion of functions. Do not access these addresses; the correct operation of LSI is not guaranteed if they are accessed.

## 4. Clock Signals

After applying a reset, only release the reset line after the operating clock signal has become stable. When switching the clock signal during program execution, wait until the target clock signal has stabilized.

- When the clock signal is generated with an external resonator (or from an external oscillator) during a reset, ensure that the reset line is only released after full stabilization of the clock signal. Moreover, when switching to a clock signal produced with an external resonator (or by an external oscillator) while program execution is in progress, wait until the target clock signal is stable.

## 5. Differences between Products

Before changing from one product to another, i.e. to one with a different type number, confirm that the change will not lead to problems.

- The characteristics of MPU/MCU in the same group but having different type numbers may differ because of the differences in internal memory capacity and layout pattern. When changing to products of different type numbers, implement a system-evaluation test for each of the products.

# Configuration of This Manual

This manual comprises the following items:

1. General Precautions on Handling of Product
2. Configuration of This Manual
3. Preface
4. Main Revisions for This Edition (only for revised versions)

The list of revisions is a summary of points that have been revised or added to earlier versions. This does not include all of the revised contents. For details, see the actual locations in this manual.

5. Contents
6. Overview
7. Description of Functional Modules
  - CPU and System-Control Modules
  - On-Chip Peripheral Modules

The configuration of the functional description of each module differs according to the module. However, the generic style includes the following items:

- i) Feature
- ii) Input/Output Pin
- iii) Register Description
- iv) Operation
- v) Usage Note

When designing an application system that includes this LSI, take notes into account. Each section includes notes in relation to the descriptions given, and usage notes are given, as required, as the final part of each section.

8. List of Registers
9. Electrical Characteristics
10. Appendix
11. Index

# Preface

This LSI is a microcomputer (MCU) made up of the H8S/2000 CPU with Renesas Technology's original architecture as its core, and the peripheral functions required to configure a system.

The H8S/2000 CPU has an internal 32-bit configuration, sixteen 16-bit general registers, and a simple and optimized instruction set for high-speed operation. The H8S/2000 CPU can handle a 16-Mbyte linear address space.

This LSI is equipped with ROM and RAM, a direct memory access controller (DMAC), a bus master, a 16-bit timer pulse unit (TPU), a watchdog timer (WDT), a realtime clock (RTC), a universal serial bus (USB), two types of serial communication interfaces (SCIs), an A/D converter, and I/O ports as on-chip peripheral modules for system configuration.

A single-power flash memory (F-ZTAT™\*) version and masked ROM version are available for this LSI's ROM. The F-ZTAT version provides flexibility as it can be reprogrammed in no time to cope with all situations from the early stages of mass production to full-scale mass production. This is particularly applicable to application devices with specifications that will most probably change.

This manual describes this LSI's hardware.

Note: \* F-ZTAT is a trademark of Renesas Technology, Corp.

**Target Users:** This manual was written for users who will be using the H8S/2218 Group and H8S/2212 Group in the design of application systems. Target users are expected to understand the fundamentals of electrical circuits, logical circuits, and microcomputers.

**Objective:** This manual was written to explain the hardware functions and electrical characteristics of the H8S/2218 Group and H8S/2212 Group to the target users. Refer to the H8S/2600 Series, H8S/2000 Series Software Manual for a detailed description of the instruction set.

Notes on reading this manual:

- In order to understand the overall functions of the chip  
Read the manual according to the contents. This manual can be roughly categorized into parts on the CPU, system control functions, peripheral functions and electrical characteristics.
- In order to understand the details of the CPU's functions  
Read the H8S/2600 Series, H8S/2000 Series Software Manual.

- In order to understand the details of a register when its name is known  
Read the index that is the final part of the manual to find the page number of the entry on the register. The addresses, bits, and initial values of the registers are summarized in section 21, List of Registers.  
Examples: Register name: The following notation is used for cases when the same or a similar function, e.g. 16-bit timer pulse unit or serial communication, is implemented on more than one channel: XXX\_N (XXX is the register name and N is the channel number)  
Bit order: The MSB is on the left and the LSB is on the right.  
Number notation: Binary is B'xxxx, hexadecimal is H'xxxx.  
Signal notation: An overbar is added to a low-active signal:  $\overline{\text{xxxx}}$

Related Manuals: The latest versions of all related manuals are available from our web site. Please ensure you have the latest versions of all documents you require.  
<http://www.renesas.com/>

H8S/2218 Group, H8S/2212 Group Manuals:

Document Title	Document No.
H8S/2218 Group, H8S/2212 Group Hardware Manual	This manual
H8S/2600 Series, H8S/2000 Series Software Manual	REJ09B0139

User's Manuals for Development Tools:

Document Title	Document No.
H8S, H8/300 Series C/C++ Compiler, Assembler, Optimizing Linkage Editor Compiler Package Ver. 6.01 User's Manual	REJ10B0161
H8S, H8/300 Series Simulator/Debugger (for Windows) User's Manual	REJ10B0211
H8S, H8/300 Series High-performance Embedded Workshop, High-performance Debugging Interface Tutorial	ADE-702-231
High-performance Embedded Workshop User's Manual	ADE-702-201

Application Notes:

Document Title	Document No.
H8S, H8/300 Series C/C++ Compiler Package Application Note	REJ05B0464

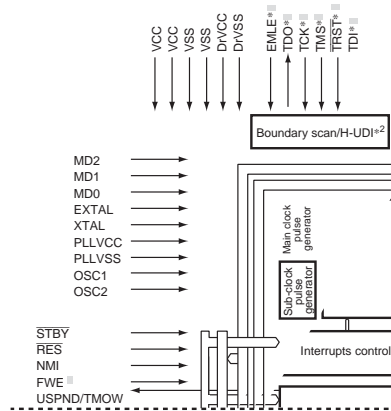


# Main Revisions for This Edition

Item	Page	Revision (See Manual for Details)																																															
1.1 Overview	1	Table amended																																															
• On-chip memory		<p>H8S/2218 Group</p> <table border="1"> <thead> <tr> <th>ROM</th> <th>Part No.</th> <th>ROM</th> <th>RAM</th> <th>Remarks</th> </tr> </thead> <tbody> <tr> <td rowspan="4">Flash memory Version</td> <td>HD64F2218</td> <td>128 kbytes</td> <td>12 kbytes</td> <td>SCI boot mode</td> </tr> <tr> <td>HD64F2218U</td> <td>128 kbytes</td> <td>12 kbytes</td> <td>USB boot mode</td> </tr> <tr> <td>HD64F2218CU</td> <td>128 kbytes</td> <td>12 kbytes</td> <td>USB boot mode</td> </tr> <tr> <td>HD64F2217CU</td> <td>64 kbytes</td> <td>12 kbytes</td> <td>USB boot mode</td> </tr> <tr> <td>Masked ROM Version</td> <td>HD6432217</td> <td>64 kbytes</td> <td>8 kbytes</td> <td>—</td> </tr> </tbody> </table>	ROM	Part No.	ROM	RAM	Remarks	Flash memory Version	HD64F2218	128 kbytes	12 kbytes	SCI boot mode	HD64F2218U	128 kbytes	12 kbytes	USB boot mode	HD64F2218CU	128 kbytes	12 kbytes	USB boot mode	HD64F2217CU	64 kbytes	12 kbytes	USB boot mode	Masked ROM Version	HD6432217	64 kbytes	8 kbytes	—																				
ROM	Part No.	ROM	RAM	Remarks																																													
Flash memory Version	HD64F2218	128 kbytes	12 kbytes	SCI boot mode																																													
	HD64F2218U	128 kbytes	12 kbytes	USB boot mode																																													
	HD64F2218CU	128 kbytes	12 kbytes	USB boot mode																																													
	HD64F2217CU	64 kbytes	12 kbytes	USB boot mode																																													
Masked ROM Version	HD6432217	64 kbytes	8 kbytes	—																																													
	2	Table amended																																															
		<p>H8S/2212 Group</p> <table border="1"> <thead> <tr> <th>ROM</th> <th>Part No.</th> <th>ROM</th> <th>RAM</th> <th>Remarks</th> </tr> </thead> <tbody> <tr> <td rowspan="7">Flash memory Version</td> <td>HD64F2212</td> <td>128 kbytes</td> <td>12 kbytes</td> <td>SCI boot mode</td> </tr> <tr> <td>HD64F2212U</td> <td>128 kbytes</td> <td>12 kbytes</td> <td>USB boot mode</td> </tr> <tr> <td>HD64F2212CU</td> <td>128 kbytes</td> <td>12 kbytes</td> <td>USB boot mode</td> </tr> <tr> <td>HD64F2211</td> <td>64 kbytes</td> <td>8 kbytes</td> <td>SCI boot mode</td> </tr> <tr> <td>HD64F2211U</td> <td>64 kbytes</td> <td>8 kbytes</td> <td>USB boot mode</td> </tr> <tr> <td>HD64F2211CU</td> <td>64 kbytes</td> <td>8 kbytes</td> <td>USB boot mode</td> </tr> <tr> <td>HD64F2210CU</td> <td>32 kbytes</td> <td>8 kbytes</td> <td>USB boot mode</td> </tr> <tr> <td rowspan="3">Masked ROM Version</td> <td>HD6432211</td> <td>64 kbytes</td> <td>8 kbytes</td> <td>—</td> </tr> <tr> <td>HD6432210</td> <td>32 kbytes</td> <td>4 kbytes</td> <td>—</td> </tr> <tr> <td>HD6432210S</td> <td>32 kbytes</td> <td>4 kbytes</td> <td>—</td> </tr> </tbody> </table>	ROM	Part No.	ROM	RAM	Remarks	Flash memory Version	HD64F2212	128 kbytes	12 kbytes	SCI boot mode	HD64F2212U	128 kbytes	12 kbytes	USB boot mode	HD64F2212CU	128 kbytes	12 kbytes	USB boot mode	HD64F2211	64 kbytes	8 kbytes	SCI boot mode	HD64F2211U	64 kbytes	8 kbytes	USB boot mode	HD64F2211CU	64 kbytes	8 kbytes	USB boot mode	HD64F2210CU	32 kbytes	8 kbytes	USB boot mode	Masked ROM Version	HD6432211	64 kbytes	8 kbytes	—	HD6432210	32 kbytes	4 kbytes	—	HD6432210S	32 kbytes	4 kbytes	—
ROM	Part No.	ROM	RAM	Remarks																																													
Flash memory Version	HD64F2212	128 kbytes	12 kbytes	SCI boot mode																																													
	HD64F2212U	128 kbytes	12 kbytes	USB boot mode																																													
	HD64F2212CU	128 kbytes	12 kbytes	USB boot mode																																													
	HD64F2211	64 kbytes	8 kbytes	SCI boot mode																																													
	HD64F2211U	64 kbytes	8 kbytes	USB boot mode																																													
	HD64F2211CU	64 kbytes	8 kbytes	USB boot mode																																													
	HD64F2210CU	32 kbytes	8 kbytes	USB boot mode																																													
Masked ROM Version	HD6432211	64 kbytes	8 kbytes	—																																													
	HD6432210	32 kbytes	4 kbytes	—																																													
	HD6432210S	32 kbytes	4 kbytes	—																																													
1.2 Internal Block Diagram	3	<p>Description amended</p> <p>The internal block diagram of the HD64F2218, HD64F2218U, HD64F2218CU and HD64F2217CU is shown in figure 1.1. The internal block diagram of the HD6432217 is shown in figure 1.2. The internal block diagram of the HD64F2212, HD64F2212U, HD64F2212CU, HD64F2211, HD64F2211U, HD64F2211CU and HD64F2210CU is shown in figure 1.3.</p>																																															

1.2 Internal Block Diagram                      3                      Title and figure amended

Figure 1.1 Internal Block Diagram of HD64F2218, HD64F2218U, HD64F2218CU and HD642217CU



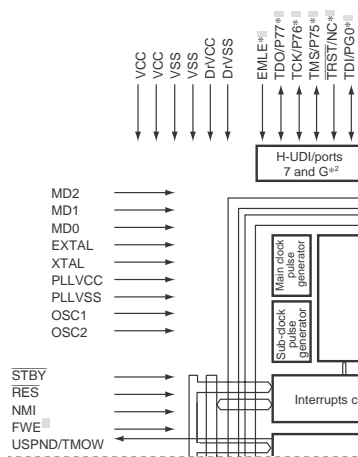
Note \*1 shown below deleted

Notes: 1. The FWE pin is provided only in the HD64F2218 and HD64F2218U.

Figure 1.2 Internal Block Diagram of HD6432217                      4                      Note amended

1. The FWE pin is provided only in the flash memory version.

Figure 1.3 Internal Block Diagram of HD64F2212, HD64F2212U, HD64F2212CU, HD64F2211, HD64F2211U, HD64F2211CU and HD64F2210CU                      5                      Title and figure amended



Note \*1 shown below deleted

Notes: 1. The FWE pin is provided only in the HD64F2212, HD64F2212U, HD64F2211 and HD64F2211U.

Item	Page	Revision (See Manual for Details)
------	------	-----------------------------------

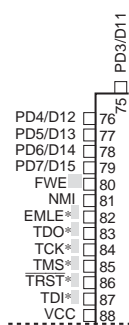
1.2 Internal Block Diagram 6 Note amended  
 1. The FWE pin is provided only in the flash memory version.

Figure 1.4 Internal Block Diagram of HD6432211, HD6432210 and HD6432210S

1.3 Pin Arrangements 7 Description amended  
 The pin arrangements of the HD64F2218, HD64F2218U, HD64F2218CU and HD64F2217CU are shown in figures 1.5 and 1.6. The pin arrangements of the HD6432217 are shown in figures 1.7 and 1.8. The pin arrangements of the HD64F2212, HD64F2212U, HD64F2212CU, HD64F2211, HD64F2211U, HD64F2211CU and HD64F2210CU are shown in figures 1.9 and 1.11.

Figure 1.5 Pin Arrangements of HD64F2218, HD64F2218U, HD64F2218CU and HD64F2217CU (TFP-100G, TFP-100GV)

Title and figure amended



Note \*1 shown below deleted

Notes: 1. The FWE pin is provided only in the HD64F2218, and HD64F2218U.

Figure 1.6 Pin Arrangements of HD64F2218, HD64F2218U, HD64F2218CU and HD64F2217CU (BP-112, BP-112V)

8 Title and figure amended

	A	B	C	D
11	NC	PD3/D11	PD0/D8	PE5/D5
10	PD5/D13	PD4/D12	PD2/D10	PE7/D7
9	FWE <sup>*1</sup>	PD7/D15	NC	PD1/D9
8	TDO <sup>*1</sup>	EMLE <sup>*1</sup>	NMI	PD6/D14
7	TRST <sup>*1</sup>	TDI <sup>*1</sup>	TMS <sup>*1</sup>	TCK <sup>*1</sup>
6	PF7/φ	VSS	VCC	PF6/AS

Note \*1 shown below deleted

Notes: 1. The FWE pin is provided only in the HD64F2218, andHD64F2218U.

Figure 1.7 Pin Arrangements of HD6432217 (TFP-100G, TFP-100GV)

9 Note amended

1. The FWE pin is provided only in the flash memory version.

Figure 1.8 Pin Arrangements of HD6432217 (BP-112, BP-112V)

10 Note amended

1. The FWE pin is provided only in the flash memory version.

Figure 1.9 Pin Arrangements of HD64F2212, HD64F2212U, HD64F2212CU, HD64F2211, HD64F2211U, HD64F2211CU and HD64F2210CU (FP-64E, FP-64EV)

11 Title and figure amended

	PE7	
	48	
FWE	□	49
NMI	□	50
EMLE <sup>*1</sup>	□	51
TDO/P77 <sup>*1</sup>	□	52
TCK/P76 <sup>*1</sup>	□	53
TMS/P75 <sup>*1</sup>	□	54
TRST/NC <sup>*1</sup>	□	55
TDI/PG0 <sup>*1</sup>	□	56
VCC	□	57

Note \*1 shown below deleted

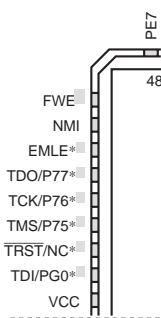
Notes: 1. The FWE pin is provided only in the HD64F2212, HD64F2212U, HD64F2211 andHD64F2211U.

Item	Page	Revision (See Manual for Details)
------	------	-----------------------------------

1.3 Pin Arrangement	12	Note amended 1. The FWE pin is provided only in the flash memory version.
---------------------	----	--

Figure 1.10 Pin Arrangements of HD6432211, HD6432210 and HD6432210S (FP-64E, FP-64EV)

Figure 1.11 Pin Arrangements of HD64F2212, HD64F2212U, HD64F2212CU, HD64F2211, HD64F2211U, HD64F2211CU and HD64F2210CU (TNP-64B, TNP-64BV)	13	Title and figure amended
--	----	--------------------------



Note \*1 shown below deleted

Notes: 1. The FWE pin is provided only in the HD64F2212, HD64F2212U, HD64F2211 and HD64F2211U.

Figure 1.12 Pin Arrangements of HD6432211, HD6432210 and HD6432210S (TNP-64B, TNP-64BV)	14	Note amended 1. The FWE pin is provided only in the flash memory version.
---	----	--

1.5 Pin Functions	26	Table amended
-------------------	----	---------------

Type	Symbol	Pin No.			I/O	Function
		TFP-100G, TFP-100GV	BP-112, BP-112V	FP-64E, FP-64EV, TNP-64B, TNP-64BV		
Boundary scan	TMS	85	C7	54	Input	Control signal input pin for the boundary scan
(Supported only by the HD64F2218, HD64F2218U, HD64F2218CU and HD64F2217CU)	TCK	84	D7	53	Input	Clock input pin for the boundary scan
	TDO	83	A8	52	Output	Data output pin for the boundary scan
	TDI	87	B7	56	Input	Data input pin for the boundary scan
	TRST	86	A7	55	Input	Reset pin for the TAP controller

Item	Page	Revision (See Manual for Details)
3.4 Memory Map in Each Operating Mode Figure 3.1 Memory Map in Each Operating Mode for HD64F2218, HD64F2218U and HD64F2218CU	77	Title amended
Figure 3.2 Memory Map in Each Operating Mode for HD64F2217CU	78	Figure added
Figure 3.4 Memory Map in Each Operating Mode for HD64F2212, HD64F2212U, HD64F2212CU, HD64F2211, HD64F2211U, HD64F2211CU, HD64F2210CU, HD6432211, HD6432210 and HD6432210S	80	Figure replaced
4.3 Reset	83	Notes amended Notes: TRST in the HD64F2218, HD64F2218U, HD64F2218CU and HD64F2217CU, which incorporate a boundary scan function, should be brought low when power is on.

12.3.7 Serial Status Register (SSR) 377 to 379

- Normal Serial Communication Interface Mode (When SMIF in SCMR is 0)

Note added

Bit	Bit Name	Initial Value	R/W	Description
7	TDRE	1	R/(W)* <sup>1</sup>	Transmit Data Register Empty ..... [Clearing conditions] • When 0 is written to TDRE after reading TDRE = 1* <sup>2</sup> .....
6	RDRF	0	R/(W)* <sup>1</sup>	Receive Data Register Full ..... [Clearing conditions] • When 0 is written to RDRF after reading RDRF = 1* <sup>2</sup> .....
5	ORER	0	R/(W)* <sup>1</sup>	Overrun Error ..... [Clearing condition] • When 0 is written to ORER after reading ORER = 1* <sup>2</sup> .....
4	FER	0	R/(W)* <sup>1</sup>	Framing Error ..... [Clearing condition] • When 0 is written to FER after reading FER = 1* <sup>2</sup> .....
3	PER	0	R/(W)* <sup>1</sup>	Parity Error ..... [Clearing condition] • When 0 is written to PER after reading PER = 1* <sup>2</sup> .....

Note: 1. The write value should always be 0 to clear the flag.  
2. To clear the flag by the CPU on the HD6432210S, reread the flag after writing 0 to it.

- Smart Card Interface 380 Mode (When SMIF in <sup>383</sup>SCMR is 1)

Note added

Bit	Bit Name	Initial Value	R/W	Description
7	TDRE	1	R/(W)* <sup>1</sup>	Transmit Data Register Empty ..... [Clearing conditions] • When 0 is written to TDRE after reading TDRE = 1* <sup>2</sup> .....
6	RDRF	0	R/(W)* <sup>1</sup>	Receive Data Register Full ..... [Clearing conditions] • When 0 is written to RDRF after reading RDRF = 1* <sup>2</sup> .....
5	ORER	0	R/(W)* <sup>1</sup>	Overrun Error ..... [Clearing condition] • When 0 is written to ORER after reading ORER = 1* <sup>2</sup> .....
4	ERS	0	R/(W)* <sup>1</sup>	Error Signal Status ..... [Clearing condition] • When 0 is written to ERS after reading ERS = 1* <sup>2</sup> .....
3	PER	0	R/(W)* <sup>1</sup>	Parity Error ..... [Clearing condition] • When 0 is written to PER after reading PER = 1* <sup>2</sup> .....

Note: 1. The write value should always be 0 to clear the flag.  
2. To clear the flag by the CPU on the HD6432210S, reread the flag after writing 0 to it.

12.3.11 Bit Rate Register (BRR)      401      Table amended

- Table 12.6 BRR Settings for Various Bit Rates (Clocked Synchronous Mode)

Bit Rate (bps)	Operating Frequency $\phi$ (MHz)					
	2		.....		24	
	n	N	n		n	N
110	3	70	—	.....		
250	2	124	2	.....		
500	1	249	2	.....	—	—
1 k	1	124	1	.....	—	—
2.5 k	0	199	1	.....	2	149
5 k	0	99	0	.....	2	74
10 k	0	49	0	.....	1	149
25 k	0	19	0	.....	0	239
50 k	0	9	0	.....	0	119
100 k	0	4	0	.....	0	59
250 k	0	1	0	.....	0	23
500 k	0	0*	0	.....	0	11
1 M			0	.....	0	5
2 M				.....	0	2
2.5 M				.....	■	■
4 M				.....		
5 M				.....	■	■
6 M				.....	0	0*

12.4.2. Receive Data Sampling Timing and Reception Margin in Asynchronous Mode      405

Figure 12.6 Receive Data Sampling Timing in Asynchronous Mode

Note added

Note: \* In this example the value of the ABCS bit in SEMRA\_0 is 0. When ABCS is set to 1, the basic clock frequency is eight times the bit rate and the receive data is sampled at the fourth rising edge of the basic clock.

Section 13 Boundary Scan Function      449

Description amended

The HD64F2218, HD64F2218U, HD64F2218CU and HD64F2217CU incorporate a boundary scan function, which is a serial I/O interface based on the JTAG (Joint Test Action Group, IEEE Std. 1149.1 and IEEE Standard Test Access Port and Boundary Scan Architecture).



Item	Page	Revision (See Manual for Details)															
13.3.2 IDCODE Register (IDCODE)	454	Description amended ...The HD64F2218, HD64F2218U, HD64F2218CU and HD64F2217CU output fixed codes H'002A200F from the TDO. ...															
Table 13.3 IDCODE Register Configuration		Table amended  <table border="1"> <thead> <tr> <th>Bits</th> </tr> </thead> <tbody> <tr> <td>HD64F2218, HD64F2218U, HD64F2218CU and HD64F2217CU codes</td> </tr> <tr> <td>Contents</td> </tr> </tbody> </table>	Bits	HD64F2218, HD64F2218U, HD64F2218CU and HD64F2217CU codes	Contents												
Bits																	
HD64F2218, HD64F2218U, HD64F2218CU and HD64F2217CU codes																	
Contents																	
14.3.5 USB FIFO Clear Register 0 (UFCLR0)	475 to 476	Bit Table amended  <table border="1"> <thead> <tr> <th>Bit</th> <th>Bit Name</th> <th>Initial Value</th> <th>R/W</th> <th>Description</th> </tr> </thead> <tbody> <tr> <td>7, 6</td> <td>—</td> <td>All 0</td> <td>R</td> <td>Reserved These bits are always read-modified.</td> </tr> <tr> <td>5</td> <td>EP2CLR</td> <td>0</td> <td>W</td> <td>EP2 Clear* 0: Performs no operation. 1: Clears EP2 OUT FIFO.</td> </tr> </tbody> </table>	Bit	Bit Name	Initial Value	R/W	Description	7, 6	—	All 0	R	Reserved These bits are always read-modified.	5	EP2CLR	0	W	EP2 Clear* 0: Performs no operation. 1: Clears EP2 OUT FIFO.
Bit	Bit Name	Initial Value	R/W	Description													
7, 6	—	All 0	R	Reserved These bits are always read-modified.													
5	EP2CLR	0	W	EP2 Clear* 0: Performs no operation. 1: Clears EP2 OUT FIFO.													
		Note added  <p>Note:* When DMA writes are enabled (EP2T1 set to 1 and EP2T0 set to 0 or 1 in UDMAR), it is not possible to clear the data in the FIFO by writing 1 to EP2CLR. To clear the data in the FIFO, disable DMA transfers (clear EP2T1 and EP2T0 in UDMAR to 0) and then write 1 to EP2CLR.</p>															
14.8.16 Clearing the FIFO when DMA Transfer Is Enabled	533	Description added When DMA transfer is enabled (EP2T1 = 1 and EP2T0 = 0 or 1 in UDMAR) at endpoint 2, it is not possible to clear OUTFIFO in EP2. It is necessary to disable DMA transfer (EP2T1 = 0 and EP2T0 = 0 in UDMAR) before clearing the FIFO.															
Section 16 RAM	551	Description amended The HD64F2218, HD64F2218U, and HD64F2218CU have 12 kbytes of on-chip high-speed static RAM. The HD6432217, HD64F2211, HD64F2211U, and HD64F2211CU have 8 kbytes of on-chip high-speed static RAM. The HD6432210 and HD6432210S have 4 kbytes of on-chip high-speed static RAM. The RAM is connected to the CPU by a 16-bit data bus, enabling one-state access by the CPU to both byte data and word data.															

Table amended

Product Class	ROM Type	RAM Size	RAM Address
H8S/2218 Group	HD64F2218	Flash memory Version	12 kbytes
	HD64F2218U		
	HD64F2218CU		
	HD64F2217CU		
	HD6432217	Masked ROM Version	8 kbytes
H8S/2212 Group	HDF64F2212	Flash memory Version	12 kbytes
	HDF64F2212U		
	HDF64F2212CU		
	HD64F2211		8 kbytes
	HD64F2211U		
	HD64F2211CU		
	HD64F2210CU		
	HD6432211	Masked ROM Version	8 kbytes
			H'FFD000 to H'FFEFBF H'FFFC00 to H'FFFEFBF
	HD6432210		4 kbytes
	HD6432210S		H'FFE000 to H'FFEFBF H'FFFC00 to H'FFFEFBF

Table amended

- Size:

Product Class	ROM Size	ROM Address
H8S/2218 Group	HD64F2218, HD64F2218U	128 kbytes
	HD64F2218CU	
	HD64F2217CU	64 kbytes
H8S/2212 Group	HD64F2212, HD64F2212U	128 kbytes
	HD64F2212CU	
	HD64F2211, HD64F2211U	64 kbytes
	HD64F2211CU	
	HD64F2210CU	32 kbytes

- Two flash memory operating modes

Description amended

— Boot mode

SCI boot mode: HD64F2218, HD64F2212, and HD64F2211

USB boot mode: HD64F2218U, HD64F2218CU, HD64F2217CU, HD64F2212U, HD64F2212CU, HD64F2211U, HD64F2211CU and HD64F2210CU

Item	Page	Revision (See Manual for Details)																								
17.1 Features	554	Note amended																								
Figure 17.1 Block Diagram of Flash Memory		Note: * 128 kbytes in the HD64F2218, HD64F2218U, HD64F2218CU, HD64F2212, HD64F2212U and HD64F2212CU; 64 kbytes in the HD64F2217CU, HD64F2211, HD64F2211U and HD64F2211CU. 32 kbytes in the HD64F2210CU																								
17.3 Block Configuration	558	Description amended																								
Figure 17.5 Flash Memory Block Configuration (HD64F2218, HD64F2218U, HD64F2218CU, HD64F2212, HD64F2212U, HD64F2212CU)		Figure 17.5 shows the block configuration of 128-kbyte flash memory in the HD64F2218, HD64F2218U, HD64F2218CU, HD64F2212, HD64F2212U and HD64F2212CU.  Title amended																								
17.6 Flash Memory Block Configuration (HD64F2217CU, HD64F2211, HD64F2211U, HD64F2211CU)	559	Description and title amended																								
Figure 17.6 Flash Memory Block Configuration (HD64F2217CU, HD64F2211, HD64F2211U, HD64F2211CU)		Figure 17.6 shows the block configuration of 64-kbyte flash memory in the HD64F2217CU, HD64F2211, HD64F2211U and HD64F2211CU.																								
17.7 Flash Memory Block Configuration (HD64F2210CU)	560	Figure and description added																								
Figure 17.7 Flash Memory Block Configuration (HD64F2210CU)																										
17.4 Input/Output Pins	561	Table amended																								
Table 17.2 Pin Configuration																										
<table border="1"> <thead> <tr> <th>Pin Name</th> <th>I/O</th> <th>Function</th> <th></th> </tr> </thead> <tbody> <tr> <td>USD+, USD-</td> <td>Input/output</td> <td>USB data input/output</td> <td>HD64F2218U, HD64F2218CU,</td> </tr> <tr> <td>VBUS</td> <td>Input</td> <td>USB cable connect/cut detect</td> <td>HD64F2217CU,</td> </tr> <tr> <td>UBPM</td> <td>Input</td> <td>USB bus power mode/self power mode select</td> <td>HD64F2212U, HD64F2212CU, HD64F2211U</td> </tr> <tr> <td>USPND</td> <td>Output</td> <td>USB suspend output</td> <td></td> </tr> <tr> <td>P36 (PUPD+)</td> <td>Output</td> <td>D+ pull-up control</td> <td></td> </tr> </tbody> </table>			Pin Name	I/O	Function		USD+, USD-	Input/output	USB data input/output	HD64F2218U, HD64F2218CU,	VBUS	Input	USB cable connect/cut detect	HD64F2217CU,	UBPM	Input	USB bus power mode/self power mode select	HD64F2212U, HD64F2212CU, HD64F2211U	USPND	Output	USB suspend output		P36 (PUPD+)	Output	D+ pull-up control	
Pin Name	I/O	Function																								
USD+, USD-	Input/output	USB data input/output	HD64F2218U, HD64F2218CU,																							
VBUS	Input	USB cable connect/cut detect	HD64F2217CU,																							
UBPM	Input	USB bus power mode/self power mode select	HD64F2212U, HD64F2212CU, HD64F2211U																							
USPND	Output	USB suspend output																								
P36 (PUPD+)	Output	D+ pull-up control																								

Item	Page	Revision (See Manual for Details)
17.6 On-Board Programming Modes Table 17.3 Setting On-Board Programming Modes	567	Table amended
		<div style="border: 1px dashed black; padding: 5px;"> <p><b>Mode</b></p> <p>SCI boot mode (HD64F2218, HD64F2212, HD64F2211)</p> <p>USB boot mode (HD64F2218U, HD64F2218CU, HD64F2217CU, HD64F2212U, HD64F2212CU, HD64F2211U, HD64F2211CU, HD64F2210CU)</p> </div>
17.6.1 SCI Boot Mode (HD64F2218, HD64F2212, and HD64F2211)	569	<p>Description amended</p> <p>5. In boot mode, a part of the on-chip RAM area (four kbytes) is used by the boot program. The area to which the programming control program is transferred from the host is 8 kbytes (H'FFC000 to H'FFDFFF) in the HD64F2218 and HD64F2212 and 4 kbytes (H'FFD000 to H'FFDFFF) in the HD64F2211. The boot program area cannot be used until the execution state in boot mode switches to the programming control program.</p>
17.6.2 USB Boot Mode (HD64F2218U, HD64F2212U, and HD64F2211U)	573	<p>Description amended</p> <p>4. In boot mode, the 4-kbyte on-chip RAM area H'FFE000 to H'FFEFBF is used by the boot program. The programming control program is transferred from the host stored in the 8-kbyte area H'FFC000 to H'FFDFFF in the HD64F2218U, HD64F2218CU, HD64F2212U, and HD64F2212CU and the 4-kbyte area H'FFD000 to H'FFDFFF in the HD64F2211U, HD64F2211CU and HD64F2210CU.</p>

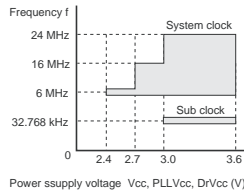
## 22.2 Power Supply Voltage and Operating Frequency Range

### Figure 22.1 Power Supply Voltage and Operating Ranges

658

Figure amended

(1) Mask ROM versions (except for HD6432210S)

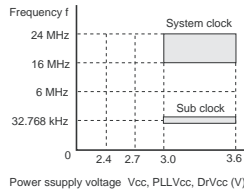


Condition A:  $V_{cc} = PLLV_{cc} = DrV_{cc} = 2.4$  to  $3.6V$   
 $V_{ref} = 2.4V$  to  $V_{cc}$   
 $V_{ss} = PLLV_{ss} = DrV_{ss} = 0V$   
 $f = 32.768$  kHz,  $6$  MHz  
 $T_a = -20$  to  $+75$  (Regular specifications)  
 $T_a = -40$  to  $+85$  (Wide-range specifications)

Condition B:  $V_{cc} = PLLV_{cc} = DrV_{cc} = 2.7$  to  $3.6V$   
 $V_{ref} = 2.7V$  to  $V_{cc}$   
 $V_{ss} = PLLV_{ss} = DrV_{ss} = 0V$   
 $f = 32.768$  kHz,  $6$  to  $16$  MHz  
 $T_a = -20$  to  $+75$  (Regular specifications)  
 $T_a = -40$  to  $+85$  (Wide-range specifications)

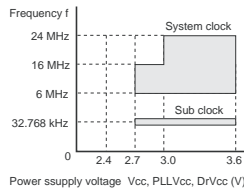
Condition C:  $V_{cc} = PLLV_{cc} = DrV_{cc} = 3.0$  to  $3.6V$   
 $V_{ref} = 3.0V$  to  $V_{cc}$   
 $V_{ss} = PLLV_{ss} = DrV_{ss} = 0V$   
 $f = 32.768$  kHz,  $6$  to  $24$  MHz  
 $T_a = -20$  to  $+75$  (Regular specifications)  
 $T_a = -40$  to  $+85$  (Wide-range specifications)

(2) Masked ROM version (HD6432210S)



Condition D:  $V_{cc} = PLLV_{cc} = DrV_{cc} = 3.0$  to  $3.6V$   
 $V_{ref} = 3.0V$  to  $V_{cc}$   
 $V_{ss} = PLLV_{ss} = DrV_{ss} = 0V$   
 $f = 32.768$  kHz,  $16$  to  $24$  MHz  
 $T_a = -20$  to  $+75$  (Regular specifications)  
 $T_a = -40$  to  $+85$  (Wide-range specifications)

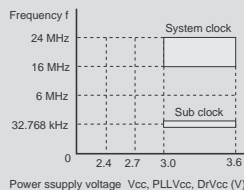
(3) F-ZTAT versions (except for H8S/2218C, H8S/2212C)



Condition A: None  
 Condition B:  $V_{cc} = PLLV_{cc} = DrV_{cc} = 2.7$  to  $3.6V$   
 $V_{ref} = 2.7V$  to  $V_{cc}$   
 $V_{ss} = PLLV_{ss} = DrV_{ss} = 0V$   
 $f = 32.768$  kHz,  $6$  to  $16$  MHz  
 $T_a = -20$  to  $+75$  (Regular specifications)  
 $T_a = -40$  to  $+85$  (Wide-range specifications)

Condition C:  $V_{cc} = PLLV_{cc} = DrV_{cc} = 3.0$  to  $3.6V$   
 $V_{ref} = 3.0V$  to  $V_{cc}$   
 $V_{ss} = PLLV_{ss} = DrV_{ss} = 0V$   
 $f = 32.768$  kHz,  $6$  to  $24$  MHz  
 $T_a = -20$  to  $+75$  (Regular specifications)  
 $T_a = -40$  to  $+85$  (Wide-range specifications)

(4) F-ZTAT versions (H8S/2218C, H8S/2212C)



Condition D:  $V_{cc} = PLLV_{cc} = DrV_{cc} = 3.0$  to  $3.6V$   
 $V_{ref} = 3.0V$  to  $V_{cc}$   
 $V_{ss} = PLLV_{ss} = DrV_{ss} = 0V$   
 $f = 32.768$  kHz,  $6$  to  $24$  MHz  
 $T_a = -20$  to  $+75$  (Regular specifications)  
 $T_a = -40$  to  $+85$  (Wide-range specifications)

(5) When using the on-chip USB

**Item**                      **Page**                      **Revision (See Manual for Details)**

B. Product Model      689 to  
Lineup                      690                      Table amended

Product Class	Part No.	Model Name	Marking	Package (code)
H8S/2218 Group	Flash memory Version	HD64F2218	HD64F2218TF24      F2218TF24	100-pin TQFP (TFP-100G, TFP-100GV)
			HD64F2218BR24      64F2218BR24	112-pin P-LFBGA (BP-112, BP-112V)
-----				
		HD64F2218CU	HD64F2218CUTF24      F2218CUTF24	100-pin TQFP (TFP-100GV)
			HD64F2218CUBR24      64F2218CUBR24	112-pin P-LFBGA (BP-112V)
		HD64F2217CU	HD64F2217CUTF24      F2217CUTF24	100-pin TQFP (TFP-100GV)
			HD64F2217CUBR24      64F2217CUBR24	112-pin P-LFBGA (BP-112V)
-----				
	Masked ROM	HD6432217	HD6432217(***)TF      2217(***)TF	100-pin TQFP (TFP-100G, TFP-100GV)
-----				
H8S/2212 Group	Flash memory Version	HD64F2212	HD64F2212FP24      2212FP24	64-pin LQFP (FP-64E, FP-64EV)
				HD64F2212NP24      F2212NP24
		HD64F2212U	HD64F2212UFP24      2212UFP24	64-pin LQFP (FP-64E, FP-64EV)
				HD64F2212UNP24      F2212UNP24
		HD64F2212CU	HD64F2212CUFP24      2212CUFP24	64-pin LQFP (FP-64EV)
				HD64F2212CUNP24      F2212CUNP24
		HD64F2211	HD64F2211FP24      2211FP24	64-pin LQFP
		HD64F2211U	HD64F2211UFP24      2211UFP24	64-pin LQFP (FP-64E, FP-64EV)
				HD64F2211UNP24      F2211UNP24
		HD64F2211CU	HD64F2211CUFP24      2211CUFP24	64-pin LQFP (FP-64EV)
	HD64F2211CUNP24      F2211CUNP24		64-pin VQFN (TNP-64BV)	
HD64F2210CU	HD64F2210CUFP24      2210CUFP24	64-pin LQFP (FP-64EV)		
		HD64F2210CUNP24      F2210CUNP24	64-pin VQFN (TNP-64BV)	
-----				

All trademarks and registered trademarks are the property of their respective owners.



# Contents

Section 1 Overview .....	1
1.1 Overview .....	1
1.2 Internal Block Diagram .....	3
1.3 Pin Arrangements .....	7
1.4 Pin Functions in Each Operating Mode .....	15
1.5 Pin Functions .....	21
Section 2 CPU .....	31
2.1 Features .....	31
2.1.1 Differences between H8S/2600 CPU and H8S/2000 CPU .....	32
2.1.2 Differences from H8/300 CPU .....	33
2.1.3 Differences from H8/300H CPU .....	33
2.2 CPU Operating Modes .....	34
2.2.1 Normal Mode .....	34
2.2.2 Advanced Mode .....	36
2.3 Address Space .....	38
2.4 Register Configuration .....	39
2.4.1 General Registers .....	40
2.4.2 Program Counter (PC) .....	41
2.4.3 Extended Control Register (EXR) .....	41
2.4.4 Condition-Code Register (CCR) .....	42
2.4.5 Initial Register Values .....	43
2.5 Data Formats .....	43
2.5.1 General Register Data Formats .....	43
2.5.2 Memory Data Formats .....	45
2.6 Instruction Set .....	45
2.6.1 Table of Instructions Classified by Function .....	47
2.6.2 Basic Instruction Formats .....	57
2.7 Addressing Modes and Effective Address Calculation .....	58
2.7.1 Register Direct—Rn .....	58
2.7.2 Register Indirect—@ERn .....	58
2.7.3 Register Indirect with Displacement—@(d:16, ERn) or @(d:32, ERn) .....	59
2.7.4 Register Indirect with Post-Increment or Pre-Decrement—@ERn+ or @-ERn ..	59
2.7.5 Absolute Address—@aa:8, @aa:16, @aa:24, or @aa:32 .....	59
2.7.6 Immediate—#xx:8, #xx:16, or #xx:32 .....	60
2.7.7 Program-Counter Relative—@(d:8, PC) or @(d:16, PC) .....	60
2.7.8 Memory Indirect—@@aa:8 .....	61
2.7.9 Effective Address Calculation .....	62

2.8	Processing States .....	64
2.9	Usage Notes.....	66
2.9.1	Note on TAS Instruction Usage .....	66
2.9.2	STM/LTM Instruction Usage.....	66
2.9.3	Note on Bit Manipulation Instructions .....	66
2.9.4	Accessing Registers Containing Write-Only Bits .....	68
 Section 3 MCU Operating Modes.....		71
3.1	Operating Mode Selection.....	71
3.2	Register Descriptions.....	72
3.2.1	Mode Control Register (MDCR).....	72
3.2.2	System Control Register (SYSCR) .....	72
3.3	Operating Mode Descriptions.....	74
3.3.1	Mode 4 (Supported Only by the H8S/2218 Group).....	74
3.3.2	Mode 5 (Supported Only by the H8S/2218 Group).....	74
3.3.3	Mode 6 (Supported Only by the H8S/2218 Group).....	75
3.3.4	Mode 7 .....	75
3.3.5	Pin Functions.....	76
3.4	Memory Map in Each Operating Mode.....	77
 Section 4 Exception Handling.....		81
4.1	Exception Handling Types and Priority .....	81
4.2	Exception Sources and Exception Vector Table.....	81
4.3	Reset.....	83
4.3.1	Reset Types .....	83
4.3.2	Reset Exception Handling.....	84
4.3.3	Interrupts after Reset .....	86
4.3.4	State of On-Chip Peripheral Modules after Reset Release .....	86
4.4	Traces .....	87
4.5	Interrupts .....	87
4.6	Trap Instruction .....	88
4.7	Stack Status after Exception Handling .....	89
4.8	Notes on Use of the Stack .....	90
 Section 5 Interrupt Controller.....		91
5.1	Features .....	91
5.2	Input/Output Pins .....	93
5.3	Register Descriptions.....	93
5.3.1	Interrupt Priority Registers A to G, J, K, M (IPRA to IPRG, IPRJ, IPRK, IPRM) .....	94
5.3.2	IRQ Enable Register (IER).....	95



5.3.3	IRQ Sense Control Registers H and L (ISCRH, ISCLR).....	96
5.3.4	IRQ Status Register (ISR).....	98
5.4	Interrupt Sources.....	99
5.4.1	External Interrupts.....	99
5.4.2	Internal Interrupts.....	100
5.5	Interrupt Exception Handling Vector Table.....	101
5.6	Interrupt Control Modes and Interrupt Operation.....	103
5.6.1	Interrupt Control Mode 0.....	103
5.6.2	Interrupt Control Mode 2.....	105
5.6.3	Interrupt Exception Handling Sequence.....	107
5.6.4	Interrupt Response Times.....	108
5.6.5	DMAC Activation by Interrupt.....	109
5.7	Usage Notes.....	112
5.7.1	Contention between Interrupt Generation and Disabling.....	112
5.7.2	Instructions that Disable Interrupts.....	113
5.7.3	Times when Interrupts Are Disabled.....	113
5.7.4	Interrupts during Execution of EEPMOV Instruction.....	113
5.7.5	IRQ Interrupt.....	113
5.7.6	NMI Interrupt Usage Notes.....	114
Section 6 Bus Controller.....		115
6.1	Features.....	115
6.2	Input/Output Pins.....	117
6.3	Register Descriptions.....	118
6.3.1	Bus Width Control Register (ABWCR).....	118
6.3.2	Access State Control Register (ASTCR).....	119
6.3.3	Wait Control Registers H and L (WCRH, WCRL).....	120
6.3.4	Bus Control Register H (BCRH).....	124
6.3.5	Bus Control Register L (BCRL).....	125
6.3.6	Pin Function Control Register (PFCR).....	126
6.4	Bus Control.....	127
6.4.1	Area Divisions.....	127
6.4.2	Bus Specifications.....	128
6.4.3	Bus Interface for Each Area.....	129
6.4.4	Chip Select Signals.....	130
6.5	Basic Timing.....	131
6.5.1	On-Chip Memory (ROM, RAM) Access Timing.....	131
6.5.2	On-Chip Peripheral Module Access Timing.....	132
6.5.3	External Address Space Access Timing.....	133
6.6	Basic Bus Interface.....	134
6.6.1	Data Size and Data Alignment (Supported Only by the H8S/2218 Group).....	134

6.6.2	Valid Strobes .....	135
6.6.3	Basic Timing .....	136
6.6.4	Wait Control .....	145
6.7	Burst ROM Interface .....	147
6.7.1	Basic Timing .....	147
6.7.2	Wait Control .....	149
6.8	Idle Cycle .....	149
6.9	Bus Release .....	153
6.9.1	Bus Release Usage Note.....	154
6.10	Bus Arbitration .....	155
6.10.1	Operation .....	155
6.10.2	Bus Transfer Timing .....	155
6.10.3	External Bus Release Usage Note .....	156
6.11	Resets and the Bus Controller .....	156
<b>Section 7 DMA Controller (DMAC).....</b>		<b>157</b>
7.1	Features .....	157
7.2	Register Configuration .....	159
7.3	Register Descriptions.....	161
7.3.1	Memory Address Registers (MAR).....	161
7.3.2	I/O Address Register (IOAR).....	161
7.3.3	Execute Transfer Count Register (ETCR).....	162
7.3.4	DMA Control Register (DMACR).....	163
7.3.5	DMA Band Control Register (DMABCR).....	169
7.4	Operation.....	177
7.4.1	Transfer Modes .....	177
7.4.2	Sequential Mode.....	178
7.4.3	Idle Mode .....	181
7.4.4	Repeat Mode .....	183
7.4.5	Normal Mode .....	186
7.4.6	Block Transfer Mode.....	189
7.4.7	DMAC Activation Sources .....	194
7.4.8	Basic DMAC Bus Cycles.....	196
7.4.9	DMAC Bus Cycles (Dual Address Mode).....	197
7.4.10	DMAC Multi-Channel Operation.....	202
7.4.11	Relation between the DMAC and External Bus Requests.....	203
7.4.12	NMI Interrupts and DMAC.....	203
7.4.13	Forced Termination of DMAC Operation .....	204
7.4.14	Clearing Full Address Mode .....	205
7.5	Interrupts .....	206
7.6	Usage Notes.....	207

7.6.1	DMAC Register Access during Operation.....	207
7.6.2	Module Stop.....	208
7.6.3	Medium-Speed Mode.....	208
7.6.4	Activation Source Acceptance.....	209
7.6.5	Internal Interrupt after End of Transfer.....	209
7.6.6	Channel Re-Setting.....	209
<b>Section 8 I/O Ports .....</b>		<b>211</b>
8.1	Port 1.....	216
8.1.1	Port 1 Data Direction Register (P1DDR).....	216
8.1.2	Port 1 Data Register (P1DR).....	217
8.1.3	Port 1 Register (PORT1).....	217
8.1.4	Pin Functions .....	218
8.2	Port 3.....	223
8.2.1	Port 3 Data Direction Register (P3DDR).....	223
8.2.2	Port 3 Data Register (P3DR).....	224
8.2.3	Port 3 Register (PORT3).....	224
8.2.4	Port 3 Open-Drain Control Register (P3ODR).....	225
8.2.5	Pin Functions .....	225
8.3	Port 4.....	227
8.3.1	Port 4 Register (PORT4).....	227
8.3.2	Pin Function.....	227
8.4	Port 7.....	228
8.4.1	Port 7 Data Direction Register (P7DDR).....	228
8.4.2	Port 7 Data Register (P7DR).....	229
8.4.3	Port 7 Register (PORT7).....	230
8.4.4	Pin Functions .....	231
8.5	Port 9.....	232
8.5.1	Port 9 Register (PORT9).....	232
8.5.2	Pin Function.....	232
8.6	Port A.....	233
8.6.1	Port A Data Direction Register (PADDR).....	233
8.6.2	Port A Data Register (PADR).....	234
8.6.3	Port A Register (PORTA).....	234
8.6.4	Port A Pull-Up MOS Control Register (PAPCR).....	235
8.6.5	Port A Open-Drain Control Register (PAODR).....	235
8.6.6	Pin Functions .....	236
8.6.7	Port A Input Pull-Up MOS States.....	238
8.7	Port B (H8S/2218 Group Only).....	239
8.7.1	Port B Data Direction Register (PBDDR).....	239
8.7.2	Port B Data Register (PBDR).....	240

8.7.3	Port B Register (PORTB).....	240
8.7.4	Port B Pull-Up MOS Control Register (PBPCR).....	241
8.7.5	Pin Functions.....	242
8.7.6	Port B Input Pull-Up MOS States .....	244
8.8	Port C (H8S/2218 Group Only).....	245
8.8.1	Port C Data Direction Register (PCDDR).....	245
8.8.2	Port C Data Register (PCDR).....	246
8.8.3	Port C Register (PORTC).....	246
8.8.4	Port C Pull-Up MOS Control Register (PCPCR).....	247
8.8.5	Pin Functions.....	247
8.8.6	Port C Input Pull-Up MOS States .....	249
8.9	Port D (H8S/2218 Group Only).....	250
8.9.1	Port D Data Direction Register (PDDDR) .....	250
8.9.2	Port D Data Register (PDDR) .....	251
8.9.3	Port D Register (PORTD) .....	251
8.9.4	Port D Pull-Up MOS Control Register (PDPCR).....	252
8.9.5	Pin Functions.....	252
8.9.6	Port D Input Pull-Up MOS States .....	254
8.10	Port E.....	255
8.10.1	Port E Data Direction Register (PEDDR) .....	255
8.10.2	Port E Data Register (PEDR) .....	256
8.10.3	Port E Register (PORTE) .....	256
8.10.4	Port E Pull-Up MOS Control Register (PEPCR) .....	257
8.10.5	Pin Functions.....	257
8.10.6	Port E Input Pull-Up MOS States.....	260
8.11	Port F.....	261
8.11.1	Port F Data Direction Register (PFDDR).....	262
8.11.2	Port F Data Register (PFDR).....	263
8.11.3	Port F Register (PORTF).....	263
8.11.4	Clock Output Control Register (OUTCR).....	264
8.11.5	Pin Functions.....	264
8.12	Port G .....	267
8.12.1	Port G Data Direction Register (PGDDR) .....	268
8.12.2	Port G Data Register (PGDR) .....	269
8.12.3	Port G Register (PORTG) .....	269
8.12.4	Pin Functions.....	270
8.13	Handling of Unused Pins.....	271
Section 9 16-Bit Timer Pulse Unit (TPU).....		273
9.1	Features .....	273
9.2	Input/Output Pins .....	277

9.3	Register Descriptions .....	278
9.3.1	Timer Control Register (TCR) .....	279
9.3.2	Timer Mode Register (TMDR) .....	282
9.3.3	Timer I/O Control Register (TIOR) .....	284
9.3.4	Timer Interrupt Enable Register (TIER) .....	293
9.3.5	Timer Status Register (TSR) .....	294
9.3.6	Timer Counter (TCNT) .....	297
9.3.7	Timer General Register (TGR) .....	297
9.3.8	Timer Start Register (TSTR) .....	297
9.3.9	Timer Synchro Register (TSYR) .....	298
9.4	Interface to Bus Master .....	299
9.4.1	16-Bit Registers .....	299
9.4.2	8-Bit Registers .....	299
9.5	Operation .....	301
9.5.1	Basic Functions .....	301
9.5.2	Synchronous Operation .....	307
9.5.3	Buffer Operation .....	309
9.5.4	PWM Modes .....	313
9.5.5	Phase Counting Mode .....	317
9.6	Interrupts .....	322
9.6.1	Interrupt Source and Priority .....	322
9.6.2	DMAC Activation .....	323
9.6.3	A/D Converter Activation .....	323
9.7	Operation Timing .....	324
9.7.1	Input/Output Timing .....	324
9.7.2	Interrupt Signal Timing .....	327
9.8	Usage Notes .....	331
Section 10 Watchdog Timer (WDT) .....		339
10.1	Features .....	339
10.2	Register Descriptions .....	340
10.2.1	Timer Counter (TCNT) .....	340
10.2.2	Timer Control/Status Register (TCSR) .....	340
10.2.3	Reset Control/Status Register (RSTCSR) .....	342
10.3	Operation .....	343
10.3.1	Watchdog Timer Mode .....	343
10.3.2	Timing of Setting of Watchdog Timer Overflow Flag (WOVF) .....	344
10.3.3	Interval Timer Mode .....	344
10.3.4	Timing of Setting of Overflow Flag (OVF) .....	345
10.4	Interrupts .....	345
10.5	Usage Notes .....	346

10.5.1	Notes on Register Access .....	346
10.5.2	Contention between Timer Counter (TCNT) Write and Increment.....	347
10.5.3	Changing Value of CKS2 to CKS0 .....	348
10.5.4	Switching between Watchdog Timer Mode and Interval Timer Mode .....	348
10.5.5	Internal Reset in Watchdog Timer Mode .....	348
10.5.6	OVF Flag Clearing in Interval Timer Mode.....	348
<b>Section 11 Realtime Clock (RTC) .....</b>		<b>349</b>
11.1	Features .....	349
11.2	Input/Output Pin .....	350
11.3	Register Descriptions.....	350
11.3.1	Second Data Register (RSECDR) .....	350
11.3.2	Minute Data Register (RMINDR) .....	351
11.3.3	Hour Data Register (RHRDR).....	352
11.3.4	Day-of-Week Data Register (RWKDR).....	353
11.3.5	RTC Control Register 1 (RTCCR1) .....	354
11.3.6	RTC Control Register 2 (RTCCR2) .....	355
11.3.7	Clock Source Select Register (RTCCSR) .....	356
11.3.8	Extended Module Stop Register (EXMDLSTP) .....	357
11.4	Operation.....	358
11.4.1	Initial Settings of Registers after Power-On and Resetting Procedure .....	358
11.4.2	Time Data Reading Procedure.....	359
11.5	Interrupt Source.....	360
11.6	Operating State in Each Mode.....	361
11.7	Usage Notes.....	362
<b>Section 12 Serial Communication Interface.....</b>		<b>363</b>
12.1	Features .....	363
12.1.1	Block Diagram .....	365
12.2	Input/Output Pins .....	367
12.3	Register Descriptions.....	367
12.3.1	Receive Shift Register (RSR).....	368
12.3.2	Receive Data Register (RDR) .....	368
12.3.3	Transmit Data Register (TDR).....	368
12.3.4	Transmit Shift Register (TSR).....	368
12.3.5	Serial Mode Register (SMR).....	369
12.3.6	Serial Control Register (SCR).....	373
12.3.7	Serial Status Register (SSR).....	377
12.3.8	Smart Card Mode Register (SCMR) .....	383
12.3.9	Serial Extended Mode Register A_0 (SEMRA_0).....	384
12.3.10	Serial Extended Mode Register B_0 (SEMRB_0) .....	386

12.3.11	Bit Rate Register (BRR) .....	395
12.4	Operation in Asynchronous Mode .....	403
12.4.1	Data Transfer Format .....	404
12.4.2	Receive Data Sampling Timing and Reception Margin in Asynchronous Mode .....	405
12.4.3	Clock .....	406
12.4.4	SCI Initialization (Asynchronous Mode) .....	407
12.4.5	Data Transmission (Asynchronous Mode) .....	408
12.4.6	Serial Data Reception (Asynchronous Mode) .....	410
12.5	Multiprocessor Communication Function .....	413
12.5.1	Multiprocessor Serial Data Transmission .....	415
12.5.2	Multiprocessor Serial Data Reception .....	416
12.6	Operation in Clocked Synchronous Mode .....	419
12.6.1	Clock .....	419
12.6.2	SCI Initialization (Clocked Synchronous Mode) .....	420
12.6.3	Serial Data Transmission (Clocked Synchronous Mode) .....	421
12.6.4	Serial Data Reception (Clocked Synchronous Mode) .....	424
12.6.5	Simultaneous Serial Data Transmission and Reception (Clocked Synchronous Mode) .....	425
12.7	Operation in Smart Card Interface .....	427
12.7.1	Pin Connection Example .....	427
12.7.2	Data Format (Except for Block Transfer Mode) .....	428
12.7.3	Clock .....	429
12.7.4	Block Transfer Mode .....	429
12.7.5	Receive Data Sampling Timing and Reception Margin .....	430
12.7.6	Initialization .....	431
12.7.7	Serial Data Transmission (Except for Block Transfer Mode) .....	432
12.7.8	Serial Data Reception (Except for Block Transfer Mode) .....	435
12.7.9	Clock Output Control .....	436
12.8	SCI Select Function (Clocked Synchronous Mode) .....	438
12.9	Interrupts .....	440
12.9.1	Interrupts in Normal Serial Communication Interface Mode .....	440
12.9.2	Interrupts in Smart Card Interface Mode .....	441
12.10	Usage Notes .....	441
12.10.1	Module Stop Mode Setting .....	441
12.10.2	Break Detection and Processing (Asynchronous Mode Only) .....	441
12.10.3	Mark State and Break Detection (Asynchronous Mode Only) .....	442
12.10.4	Receive Error Flags and Transmit Operations (Clocked Synchronous Mode Only) .....	442
12.10.5	Restrictions on Use of DMAC .....	442
12.10.6	Operation in Case of Mode Transition .....	443
12.10.7	Switching from SCK Pin Function to Port Pin Function: .....	447

Section 13	Boundary Scan Function .....	449
13.1	Features .....	449
13.2	Pin Configuration .....	451
13.3	Register Descriptions.....	452
13.3.1	Instruction Register (INSTR) .....	452
13.3.2	IDCODE Register (IDCODE).....	454
13.3.3	BYPASS Register (BYPASS).....	454
13.3.4	Boundary Scan Register (BSCANR).....	454
13.4	Boundary Scan Function Operation .....	462
13.4.1	TAP Controller .....	462
13.5	Usage Notes.....	463
Section 14	Universal Serial Bus (USB).....	465
14.1	Features .....	465
14.2	Input/Output Pins .....	467
14.3	Register Descriptions.....	467
14.3.1	USB Control Register (UCTLR).....	468
14.3.2	USB DMAC Transfer Request Register (UDMAR).....	471
14.3.3	USB Device Resume Register (UDRR).....	472
14.3.4	USB Trigger Register 0 (UTRG0) .....	473
14.3.5	USB FIFO Clear Register 0 (UFCLR0).....	475
14.3.6	USB Endpoint Stall Register 0 (UESTL0).....	476
14.3.7	USB Endpoint Stall Register 1 (UESTL1).....	477
14.3.8	USB Endpoint Data Register 0s (UEDR0s).....	477
14.3.9	USB Endpoint Data Register 0i (UEDR0i).....	477
14.3.10	USB Endpoint Data Register 0o (UEDR0o).....	478
14.3.11	USB Endpoint Data Register 3 (UEDR3).....	478
14.3.12	USB Endpoint Data Register 1 (UEDR1).....	478
14.3.13	USB Endpoint Data Register 2 (UEDR2).....	479
14.3.14	USB Endpoint Receive Data Size Register 0o (UESZ0o).....	479
14.3.15	USB Endpoint Receive Data Size Register 2 (UESZ2).....	479
14.3.16	USB Interrupt Flag Register 0 (UIFR0).....	480
14.3.17	USB Interrupt Flag Register 1 (UIFR1).....	482
14.3.18	USB Interrupt Flag Register 3 (UIFR3).....	483
14.3.19	USB Interrupt Enable Register 0 (UIER0).....	484
14.3.20	USB Interrupt Enable Register 1 (UIER1).....	485
14.3.21	USB Interrupt Enable Register 3 (UIER3).....	485
14.3.22	USB Interrupt Select Register 0 (UISR0).....	486
14.3.23	USB Interrupt Select Register 1 (UISR1).....	486
14.3.24	USB Interrupt Select Register 3 (UISR3).....	487
14.3.25	USB Data Status Register (UDSR).....	487



14.3.26	USB Configuration Value Register (UCVR)	488
14.3.27	USB Test Register 0 (UTSTR0)	489
14.3.28	USB Test Register 1 (UTSTR1)	490
14.3.29	USB Test Registers 2 and A to F (UTSTR2, UTSTRA to UTSTRF)	492
14.3.30	Module Stop Control Register B (MSTPCRB)	492
14.3.31	Extended Module Stop Register (EXMDLSTP)	493
14.4	Interrupt Sources	494
14.5	Communication Operation	497
14.5.1	Initialization	497
14.5.2	USB Cable Connection/Disconnection	498
14.5.3	Suspend and Resume Operations	502
14.5.4	Control Transfer	506
14.5.5	Interrupt-In Transfer (Endpoint 3)	512
14.5.6	Bulk-In Transfer (Dual FIFOs) (Endpoint 1)	513
14.5.7	Bulk-Out Transfer (Dual FIFOs) (Endpoint 2)	515
14.5.8	Processing of USB Standard Commands and Class/Vendor Commands	516
14.5.9	Stall Operations	517
14.6	DMA Transfer Specifications	520
14.6.1	DMAC Transfer by USB Request	520
14.6.2	DMA Transfer by Auto-Request	522
14.7	USB External Circuit Example	525
14.8	Usage Notes	527
14.8.1	Emulator Usage Notes	527
14.8.2	Bus Interface	527
14.8.3	Operating Frequency	527
14.8.4	Setup Data Reception	528
14.8.5	FIFO Clear	528
14.8.6	$\overline{\text{IRQ6}}$ Interrupt	528
14.8.7	Data Register Overread or Overwrite	528
14.8.8	Reset	529
14.8.9	EP0 Interrupt Sources Assignment	529
14.8.10	Level Shifter for VBUS and $\overline{\text{IRQx}}$ Pins	530
14.8.11	USB Endpoint Data Read and Write	530
14.8.12	Restrictions on Entering and Canceling Power-Down Mode	530
14.8.13	USB External Circuit Example	532
14.8.14	Pin Processing when USB Not Used	533
14.8.15	Notes on TR Interrupt	533
14.8.16	Clearing the FIFO when DMA Transfer Is Enabled	533
Section 15 A/D Converter		535
15.1	Features	535

15.2	Input/Output Pins .....	537
15.3	Register Descriptions.....	537
15.3.1	A/D Data Registers A to D (ADDRA to ADDRD).....	538
15.3.2	A/D Control/Status Register (ADCSR).....	538
15.3.3	A/D Control Register (ADCR).....	540
15.4	Interface to Bus Master .....	541
15.5	Operation.....	542
15.5.1	Single Mode .....	542
15.5.2	Scan Mode.....	543
15.5.3	Input Sampling and A/D Conversion Time.....	544
15.5.4	External Trigger Input Timing .....	545
15.6	Interrupts .....	546
15.7	A/D Conversion Precision Definitions .....	546
15.8	Usage Notes.....	548
15.8.1	Module Stop Mode Setting.....	548
15.8.2	Permissible Signal Source Impedance.....	548
15.8.3	Influences on Absolute Precision .....	548
15.8.4	Range of Analog Power Supply and Other Pin Settings .....	549
15.8.5	Notes on Board Design.....	549
Section 16 RAM.....		551
Section 17 Flash Memory (F-ZTAT Version).....		553
17.1	Features .....	553
17.2	Mode Transitions.....	555
17.3	Block Configuration .....	558
17.4	Input/Output Pins .....	561
17.5	Register Descriptions.....	561
17.5.1	Flash Memory Control Register 1 (FLMCR1) .....	562
17.5.2	Flash Memory Control Register 2 (FLMCR2).....	563
17.5.3	Erase Block Register 1 (EBR1).....	564
17.5.4	Erase Block Register 2 (EBR2).....	564
17.5.5	RAM Emulation Register (RAMER) .....	565
17.5.6	Serial Control Register X (SCRX) .....	566
17.6	On-Board Programming Modes .....	567
17.6.1	SCI Boot Mode (HD64F2218, HD64F2212, and HD64F2211).....	567
17.6.2	USB Boot Mode (HD64F2218U, HD64F2212U, and HD64F2211U).....	571
17.6.3	Programming/Erasing in User Program Mode .....	576
17.7	Flash Memory Emulation in RAM.....	577
17.8	Flash Memory Programming/Erasing.....	579
17.8.1	Program/Program-Verify.....	579

17.8.2	Erase/Erase-Verify .....	581
17.9	Program/Erase Protection.....	583
17.9.1	Hardware Protection .....	583
17.9.2	Software Protection.....	583
17.9.3	Error Protection.....	583
17.10	Interrupt Handling when Programming/Erasing Flash Memory.....	584
17.11	Programmer Mode .....	585
17.12	Power-Down States for Flash Memory .....	586
17.13	Flash Memory Programming and Erasing Precautions .....	587
17.14	Note on Switching from F-ZTAT Version to Masked ROM Version .....	592
<b>Section 18</b>	<b>Masked ROM .....</b>	<b>593</b>
18.1	Features.....	593
<b>Section 19</b>	<b>Clock Pulse Generator .....</b>	<b>595</b>
19.1	Register Descriptions .....	596
19.1.1	System Clock Control Register (SCKCR).....	596
19.1.2	Low Power Control Register (LPWRCR).....	597
19.2	System Clock Oscillator.....	600
19.2.1	Connecting a Crystal Resonator.....	600
19.2.2	Inputting External Clock.....	601
19.3	Duty Adjustment Circuit.....	602
19.4	Medium-Speed Clock Divider .....	602
19.5	Bus Master Clock Selection Circuit .....	602
19.6	Subclock Oscillator .....	603
19.6.1	Connecting 32.768-kHz Crystal Resonator.....	603
19.6.2	Handling Pins when Subclock Not Required.....	603
19.7	Subclock Waveform Generation Circuit.....	604
19.8	PLL Circuit for USB.....	604
19.9	Usage Notes .....	605
19.9.1	Note on Crystal Resonator .....	605
19.9.2	Note on Board Design.....	605
19.9.3	Note on Switchover of External Clock .....	605
<b>Section 20</b>	<b>Power-Down Modes.....</b>	<b>607</b>
20.1	Register Descriptions .....	611
20.1.1	Standby Control Register (SBYCR) .....	611
20.1.2	Timer Control/Status Register (TCSR_1).....	613
20.1.3	Module Stop Control Registers A to C (MSTPCRA to MSTPCRC).....	614
20.1.4	Extended Module Stop Register (EXMDLSTP).....	617
20.2	Medium-Speed Mode.....	617

20.3	Sleep Mode.....	618
20.3.1	Transition to Sleep Mode .....	618
20.3.2	Exiting Sleep Mode.....	618
20.4	Software Standby Mode .....	619
20.4.1	Transition to Software Standby Mode.....	619
20.4.2	Clearing Software Standby Mode .....	619
20.4.3	Setting Oscillation Stabilization Time after Clearing Software Standby Mode ...	620
20.4.4	Software Standby Mode Application Example .....	620
20.5	Hardware Standby Mode.....	621
20.5.1	Transition to Hardware Standby Mode .....	621
20.5.2	Clearing Hardware Standby Mode .....	621
20.5.3	Hardware Standby Mode Timing .....	622
20.5.4	Hardware Standby Mode Timings.....	622
20.6	Module Stop Mode.....	623
20.7	Watch Mode .....	624
20.7.1	Transition to Watch Mode.....	624
20.7.2	Exiting Watch Mode .....	624
20.8	Subsleep Mode .....	625
20.8.1	Transition to Sleep Mode .....	625
20.8.2	Exiting Subsleep Mode .....	625
20.9	Subactive Mode.....	626
20.9.1	Transition to Subactive Mode .....	626
20.9.2	Exiting Subactive Mode .....	626
20.10	Direct Transitions .....	627
20.10.1	Direct Transitions from High-Speed Mode to Subactive Mode .....	627
20.10.2	Direct Transitions from Subactive Mode to High-Speed Mode .....	627
20.11	$\phi$ Clock Output Disabling Function.....	627
20.12	Usage Notes.....	628
20.12.1	I/O Port Status .....	628
20.12.2	Current Dissipation during Oscillation Stabilization Wait Period.....	628
20.12.3	Flash Memory Module Stop.....	628
20.12.4	DMAC Module Stop .....	628
20.12.5	On-Chip Peripheral Module Interrupt .....	628
20.12.6	Entering Subactive/Watch Mode and DMAC and DTC Module Stop.....	629
20.12.7	Writing to MSTPCR.....	629
Section 21 List of Registers .....		631
21.1	Register Addresses (Address Order) .....	632
21.2	Register Bits .....	640
21.3	Register States in Each Operating Mode .....	649

Section 22	Electrical Characteristics.....	657
22.1	Absolute Maximum Ratings .....	657
22.2	Power Supply Voltage and Operating Frequency Range .....	658
22.3	DC Characteristics .....	659
22.4	AC Characteristics .....	663
	22.4.1 Clock Timing .....	664
	22.4.2 Control Signal Timing .....	666
	22.4.3 Bus Timing .....	668
	22.4.4 Timing of On-Chip Supporting Modules.....	675
22.5	USB Characteristics .....	680
22.6	A/D Conversion Characteristics.....	682
22.7	Flash Memory Characteristics.....	683
22.8	Usage Note.....	684
Appendix	.....	685
A.	I/O Port States in Each Processing State.....	685
B.	Product Model Lineup .....	689
C.	Package Dimensions .....	691
Index	.....	695



# Figures

## Section 1 Overview

Figure 1.1	Internal Block Diagram of HD64F2218, HD64F2218U, HD64F2218CU and HD642217CU.....	3
Figure 1.2	Internal Block Diagram of HD6432217 .....	4
Figure 1.3	Internal Block Diagram of HD64F2212, HD64F2212U, HD64F2212CU, HD64F2211, HD64F2211U, HD64F2211CU and HD64F2210CU.....	5
Figure 1.4	Internal Block Diagram of HD6432211, HD6432210 and HD6432210S.....	6
Figure 1.5	Pin Arrangements of HD64F2218, HD64F2218U, HD64F2218CU and HD64F2217CU (TFP-100G, TFP-100GV).....	7
Figure 1.6	Pin Arrangements of HD64F2218, HD64F2218U, HD64F2218CU and HD64F2217CU (BP-112, BP-112V).....	8
Figure 1.7	Pin Arrangements of HD6432217 (TFP-100G, TFP-100GV).....	9
Figure 1.8	Pin Arrangements of HD6432217 (BP-112, BP-112V) .....	10
Figure 1.9	Pin Arrangements of HD64F2212, HD64F2212U, HD64F2212CU, HD64F2211, HD64F2211U, HD64F2211CU and HD64F2210CU (FP-64E, FP-64EV).....	11
Figure 1.10	Pin Arrangements of HD6432211, HD6432210 and HD6432210S (FP-64E, FP-64EV).....	12
Figure 1.11	Pin Arrangements of HD64F2212, HD64F2212U, HD64F2212CU, HD64F2211, HD64F2211U, HD64F2211CU and HD64F2210CU (TNP-64B, TNP-64BV) .....	13
Figure 1.12	Pin Arrangements of HD6432211, HD6432210 and HD6432210S (TNP-64B, TNP-64BV) .....	14

## Section 2 CPU

Figure 2.1	Exception Vector Table (Normal Mode).....	35
Figure 2.2	Stack Structure in Normal Mode.....	35
Figure 2.3	Exception Vector Table (Advanced Mode).....	36
Figure 2.4	Stack Structure in Advanced Mode.....	37
Figure 2.5	Memory Map.....	38
Figure 2.6	CPU Registers .....	39
Figure 2.7	Usage of General Registers .....	40
Figure 2.8	Stack.....	41
Figure 2.9	General Register Data Formats (1).....	44
Figure 2.9	General Register Data Formats (2).....	44
Figure 2.10	Memory Data Formats.....	45
Figure 2.11	Instruction Formats (Examples) .....	57
Figure 2.12	Branch Address Specification in Memory Indirect Mode .....	61
Figure 2.13	State Transitions.....	65
Figure 2.14	Flowchart of Method for Accessing Registers Containing Write-Only Bits.....	69

<b>Section 3</b>	<b>MCU Operating Modes</b>	
Figure 3.1	Memory Map in Each Operating Mode for HD64F2218, HD64F2218U and HD64F2218CU .....	77
Figure 3.2	Memory Map in Each Operating Mode for HD64F2217CU .....	78
Figure 3.3	Memory Map in Each Operating Mode for HD6432217 .....	79
Figure 3.4	Memory Map in Each Operating Mode for HD64F2212, HD64F2212U, HD64F2212CU, HD64F2211, HD64F2211U, HD64F2211CU, HD64F2210CU, HD6432211, HD6432210 and HD6432210S .....	80
<b>Section 4</b>	<b>Exception Handling</b>	
Figure 4.1	Reset Sequence (Mode 4) .....	85
Figure 4.2	Reset Sequence (Modes 6 and 7) .....	86
Figure 4.3	Stack Status after Exception Handling .....	89
Figure 4.4	Operation when SP Value Is Odd .....	90
<b>Section 5</b>	<b>Interrupt Controller</b>	
Figure 5.1	Block Diagram of Interrupt Controller .....	92
Figure 5.2	Block Diagram of Interrupts IRQn .....	99
Figure 5.3	Timing of Setting IRQnF .....	100
Figure 5.4	Flowchart of Procedure Up to Interrupt Acceptance in Interrupt Control Mode 0 .....	104
Figure 5.5	Flowchart of Procedure Up to Interrupt Acceptance in Interrupt Control Mode 2 .....	106
Figure 5.6	Interrupt Exception Handling .....	107
Figure 5.7	Interrupt Control for DMAC .....	110
Figure 5.8	Contention between Interrupt Generation and Disabling .....	112
<b>Section 6</b>	<b>Bus Controller</b>	
Figure 6.1	Block Diagram of Bus Controller .....	116
Figure 6.2	Overview of Area Divisions .....	127
Figure 6.3	$\overline{CS}_n$ Signal Output Timing (n = 0 to 5) .....	130
Figure 6.4	On-Chip Memory Access Cycle .....	131
Figure 6.5	Pin States during On-Chip Memory Access .....	132
Figure 6.6	On-Chip Peripheral Module Access Cycle .....	132
Figure 6.7	Pin States during On-Chip Peripheral Module Access .....	133
Figure 6.8	Access Sizes and Data Alignment Control (8-Bit Access Space) .....	134
Figure 6.9	Access Sizes and Data Alignment Control (16-Bit Access Space) .....	135
Figure 6.10	Bus Timing for 8-Bit 2-State Access Space .....	136
Figure 6.11	Bus Timing for 8-Bit 3-State Access Space (Except Area 6) .....	137
Figure 6.12	Bus Timing for Area 6 and RTC .....	138
Figure 6.13	Bus Timing for 16-Bit 2-State Access Space (1) (Even Address Byte Access) .....	139



Figure 6.14	Bus Timing for 16-Bit 2-State Access Space (2) (Odd Address Byte Access) .....	140
Figure 6.15	Bus Timing for 16-Bit 2-State Access Space (3) (Word Access).....	141
Figure 6.16	Bus Timing for 16-Bit 3-State Access Space (1) (Even Address Byte Access) .....	142
Figure 6.17	Bus Timing for 16-Bit 3-State Access Space (2) (Odd Address Byte Access) .....	143
Figure 6.18	Bus Timing for 16-Bit 3-State Access Space (3) (Word Access).....	144
Figure 6.19	Example of Wait State Insertion Timing .....	146
Figure 6.20	Example of Burst ROM Access Timing (When AST0 = BRSTS1 = 1).....	148
Figure 6.21	Example of Burst ROM Access Timing (When AST0 = BRSTS1 = 0).....	148
Figure 6.22	Example of Idle Cycle Operation (1) .....	150
Figure 6.23	Example of Idle Cycle Operation (2) .....	151
Figure 6.24	Relationship between Chip Select ( $\overline{CS}$ ) and Read ( $\overline{RD}$ ).....	152
Figure 6.25	Bus-Released State Transition Timing .....	154

## Section 7 DMA Controller (DMAC)

Figure 7.1	Block Diagram of DMAC .....	158
Figure 7.2	Operation in Sequential Mode.....	179
Figure 7.3	Example of Sequential Mode Setting Procedure .....	180
Figure 7.4	Operation in Idle Mode .....	181
Figure 7.5	Example of Idle Mode Setting Procedure.....	182
Figure 7.6	Operation in Repeat mode.....	184
Figure 7.7	Example of Repeat Mode Setting Procedure.....	185
Figure 7.8	Operation in Normal Mode .....	187
Figure 7.9	Example of Normal Mode Setting Procedure.....	188
Figure 7.10	Operation in Block Transfer Mode (BLKDIR = 0).....	190
Figure 7.11	Operation in Block Transfer Mode (BLKDIR = 1).....	191
Figure 7.12	Operation Flow in Block Transfer Mode .....	192
Figure 7.13	Example of Block Transfer Mode Setting Procedure.....	193
Figure 7.14	Example of DMA Transfer Bus Timing.....	196
Figure 7.15	Example of Short Address Mode Transfer.....	197
Figure 7.16	Example of Full Address Mode (Cycle Steal) Transfer .....	198
Figure 7.17	Example of Full Address Mode (Burst Mode) Transfer.....	199
Figure 7.18	Example of Full Address Mode (Block Transfer Mode) Transfer .....	200
Figure 7.19	Example of DREQ Level Activated Normal Mode Transfer .....	201
Figure 7.20	Example of Multi-Channel Transfer .....	202
Figure 7.21	Example of Procedure for Continuing Transfer on Channel Interrupted by NMI Interrupt .....	204
Figure 7.22	Example of Procedure for Forcibly Terminating DMAC Operation.....	204
Figure 7.23	Example of Procedure for Clearing Full Address Mode .....	205
Figure 7.24	Block Diagram of Transfer End/Transfer Break Interrupt .....	206
Figure 7.25	DMAC Register Update Timing .....	207
Figure 7.26	Contention between DMAC Register Update and CPU Read.....	208

Section 9	16-Bit Timer Pulse Unit (TPU)	
Figure 9.1	Block Diagram of TPU	274
Figure 9.2	16-Bit Register Access Operation [Bus Master ↔ TCNT (16 Bits)]	299
Figure 9.3	8-Bit Register Access Operation [Bus Master ↔ TCR (Upper 8 Bits)]	300
Figure 9.4	8-Bit Register Access Operation [Bus Master ↔ TMDR (Lower 8 Bits)]	300
Figure 9.5	8-Bit Register Access Operation [Bus Master ↔ TCR and TMDR (16 Bits)]	300
Figure 9.6	Example of Counter Operation Setting Procedure	301
Figure 9.7	Free-Running Counter Operation	302
Figure 9.8	Periodic Counter Operation	303
Figure 9.9	Example of Setting Procedure for Waveform Output by Compare Match	303
Figure 9.10	Example of 0 Output/1 Output Operation	304
Figure 9.11	Example of Toggle Output Operation	304
Figure 9.12	Example of Input Capture Operation Setting Procedure	305
Figure 9.13	Example of Input Capture Operation	306
Figure 9.14	Example of Synchronous Operation Setting Procedure	307
Figure 9.15	Example of Synchronous Operation	308
Figure 9.16	Compare Match Buffer Operation	309
Figure 9.17	Input Capture Buffer Operation	309
Figure 9.18	Example of Buffer Operation Setting Procedure	310
Figure 9.19	Example of Buffer Operation (1)	311
Figure 9.20	Example of Buffer Operation (2)	312
Figure 9.21	Example of PWM Mode Setting Procedure	314
Figure 9.22	Example of PWM Mode Operation (1)	315
Figure 9.23	Example of PWM Mode Operation (2)	315
Figure 9.24	Example of PWM Mode Operation (3)	316
Figure 9.25	Example of Phase Counting Mode Setting Procedure	317
Figure 9.26	Example of Phase Counting Mode 1 Operation	318
Figure 9.27	Example of Phase Counting Mode 2 Operation	319
Figure 9.28	Example of Phase Counting Mode 3 Operation	320
Figure 9.29	Example of Phase Counting Mode 4 Operation	321
Figure 9.30	Count Timing in Internal Clock Operation	324
Figure 9.31	Count Timing in External Clock Operation	324
Figure 9.32	Output Compare Output Timing	325
Figure 9.33	Input Capture Input Signal Timing	325
Figure 9.34	Counter Clear Timing (Compare Match)	326
Figure 9.35	Counter Clear Timing (Input Capture)	326
Figure 9.36	Buffer Operation Timing (Compare Match)	327
Figure 9.37	Buffer Operation Timing (Input Capture)	327
Figure 9.38	TGI Interrupt Timing (Compare Match)	328
Figure 9.39	TGI Interrupt Timing (Input Capture)	328
Figure 9.40	TCIV Interrupt Setting Timing	329

Figure 9.41	TCIU Interrupt Setting Timing.....	329
Figure 9.42	Timing for Status Flag Clearing by CPU .....	330
Figure 9.43	Timing for Status Flag Clearing by DMAC Activation .....	330
Figure 9.44	Phase Difference, Overlap, and Pulse Width in Phase Counting Mode .....	331
Figure 9.45	Contention between TCNT Write and Clear Operations.....	332
Figure 9.46	Contention between TCNT Write and Increment Operations .....	332
Figure 9.47	Contention between TGR Write and Compare Match.....	333
Figure 9.48	Contention between Buffer Register Write and Compare Match.....	334
Figure 9.49	Contention between TGR Read and Input Capture .....	334
Figure 9.50	Contention between TGR Write and Input Capture .....	335
Figure 9.51	Contention between Buffer Register Write and Input Capture.....	336
Figure 9.52	Contention between Overflow and Counter Clearing .....	336
Figure 9.53	Contention between TCNT Write and Overflow.....	337

## Section 10 Watchdog Timer (WDT)

Figure 10.1	Block Diagram of WDT .....	340
Figure 10.2	Operation in Watchdog Timer Mode.....	343
Figure 10.3	Timing of WOVF Setting.....	344
Figure 10.4	Operation in Interval Timer Mode .....	344
Figure 10.5	Timing of OVF Setting.....	345
Figure 10.6	Format of Data Written to TCNT and TCSR .....	346
Figure 10.7	Format of Data Written to RSTCSR (Example of WDT0) .....	347
Figure 10.8	Contention between TCNT Write and Increment.....	347

## Section 11 Realtime Clock (RTC)

Figure 11.1	Block Diagram of RTC .....	349
Figure 11.2	Definition of Time Expression .....	354
Figure 11.3	Initial Setting Procedure.....	358
Figure 11.4	Example: Reading of Inaccurate Time Data.....	359
Figure 11.5	Initializing Procedure in Using RTC Interrupt.....	361
Figure 11.6	Example of RTC Interrupt Handling Routine .....	361

## Section 12 Serial Communication Interface

Figure 12.1	Block Diagram of SCI_0.....	365
Figure 12.2	Block Diagram of SCI_2.....	366
Figure 12.3	Examples of Base Clock when Average Transfer Rate Is Selected (1).....	388
Figure 12.3	Examples of Base Clock when Average Transfer Rate Is Selected (2).....	389
Figure 12.3	Examples of Base Clock when Average Transfer Rate Is Selected (3).....	390
Figure 12.4	Example of Average Transfer Rate Setting when TPU Clock Is Input (1).....	391
Figure 12.4	Example of Average Transfer Rate Setting when TPU Clock Is Input (2).....	392
Figure 12.4	Example of Average Transfer Rate Setting when TPU Clock Is Input (3).....	393

Figure 12.4	Example of Average Transfer Rate Setting when TPU Clock Is Input (4)	394
Figure 12.5	Data Format in Asynchronous Communication (Example with 8-Bit Data, Parity, Two Stop Bits)	403
Figure 12.6	Receive Data Sampling Timing in Asynchronous Mode	405
Figure 12.7	Relationship between Output Clock and Transfer Data Phase (Asynchronous Mode)	406
Figure 12.8	Sample SCI Initialization Flowchart	407
Figure 12.9	Example of Operation in Transmission in Asynchronous Mode (Example with 8-Bit Data, Parity, One Stop Bit)	408
Figure 12.10	Sample Serial Data Transmission Flowchart	409
Figure 12.11	Example of SCI Operation in Reception (Example with 8-Bit Data, Parity, One Stop Bit)	410
Figure 12.12	Sample Serial Data Reception Flowchart (1)	411
Figure 12.12	Sample Serial Data Reception Flowchart (2)	412
Figure 12.13	Example of Communication Using Multiprocessor Format (Transmission of Data H'AA to Receiving Station A)	414
Figure 12.14	Sample Multiprocessor Serial Data Transmission Flowchart	415
Figure 12.15	Example of SCI Operation in Reception (Example with 8-Bit Data, Multiprocessor Bit, One Stop Bit)	416
Figure 12.16	Sample Multiprocessor Serial Data Reception Flowchart (1)	417
Figure 12.16	Sample Multiprocessor Serial Data Reception Flowchart (2)	418
Figure 12.17	Data Format in Synchronous Communication (For LSB-First)	419
Figure 12.18	Sample SCI Initialization Flowchart	420
Figure 12.19	Sample SCI Transmission Operation in Clocked Synchronous Mode	422
Figure 12.20	Sample Serial Data Transmission Flowchart	423
Figure 12.21	Example of SCI Operation in Reception	424
Figure 12.22	Sample Serial Data Reception Flowchart	425
Figure 12.23	Sample Flowchart of Simultaneous Serial Data Transmit and Receive Operations	426
Figure 12.24	Schematic Diagram of Smart Card Interface Pin Connections	427
Figure 12.25	Normal Smart Card Interface Data Format	428
Figure 12.26	Direct Convention ( $SDIR = SINV = O/\bar{E} = 0$ )	428
Figure 12.27	Inverse Convention ( $SDIR = SINV = O/\bar{E} = 1$ )	429
Figure 12.28	Receive Data Sampling Timing in Smart Card Mode (Using Clock of 372 Times the Transfer Rate)	430
Figure 12.29	Retransfer Operation in SCI Transmit Mode	433
Figure 12.30	TEND Flag Generation Timing in Transmission Operation	433
Figure 12.31	Example of Transmission Processing Flow	434
Figure 12.32	Retransfer Operation in SCI Receive Mode	435
Figure 12.33	Example of Reception Processing Flow	436
Figure 12.34	Timing for Fixing Clock Output Level	436

Figure 12.35 Clock Halt and Restart Procedure .....	437
Figure 12.36 Example of Communication Using the SCI Select Function .....	438
Figure 12.37 Example of Communication Using the SCI Select Function .....	439
Figure 12.38 Example of Clocked Synchronous Transmission by DMAC .....	442
Figure 12.39 Sample Flowchart for Mode Transition during Transmission .....	444
Figure 12.40 Port Pin State of Asynchronous Transmission Using Internal Clock .....	444
Figure 12.41 Port Pin State of Synchronous Transmission Using Internal Clock .....	445
Figure 12.42 Sample Flowchart for Mode Transition during Reception .....	446
Figure 12.43 Operation when Switching from SCK Pin Function to Port Pin Function .....	447
Figure 12.44 Operation when Switching from SCK Pin Function to Port Pin Function (Example of Preventing Low-Level Output).....	448

## Section 13 Boundary Scan Function

Figure 13.1 Block Diagram of Boundary Scan Function.....	450
Figure 13.2 Boundary Scan Register Configuration.....	455
Figure 13.3 TAP Controller Status Transition.....	462
Figure 13.4 Recommended Reset Signal Design.....	463
Figure 13.5 Serial Data Input/Output .....	463

## Section 14 Universal Serial Bus (USB)

Figure 14.1 Block Diagram of USB .....	466
Figure 14.2 USB Initialization.....	497
Figure 14.3 USB Cable Connection (When USB Module Stop or Power-Down Mode Is not Used).....	498
Figure 14.4 USB Cable Connection (When USB Module Stop or Power-Down Mode Is Used).....	499
Figure 14.5 USB Cable Disconnection (When USB Module Stop or Power-Down Mode Is not Used).....	500
Figure 14.6 USB Cable Disconnection (When USB Module Stop or Power-Down Mode Is Used).....	501
Figure 14.7 Example Flowchart of Suspend and Resume Operations.....	502
Figure 14.8 Example Flowchart of Suspend and Resume Interrupt Processing .....	503
Figure 14.9 Example Flowchart of Suspend and Remote-Wakeup Operations.....	504
Figure 14.10 Example Flowchart of Remote-Wakeup Interrupt Processing .....	505
Figure 14.11 Control Transfer Stage Configuration .....	506
Figure 14.12 Setup Stage Operation .....	507
Figure 14.13 Data Stage Operation (Control-In) .....	508
Figure 14.14 Data Stage Operation (Control-Out).....	509
Figure 14.15 Status Stage Operation (Control-In) .....	510
Figure 14.16 Status Stage Operation (Control-Out) .....	511
Figure 14.17 EP3 Interrupt-In Transfer Operation .....	512

Figure 14.18 EP1 Bulk-In Transfer Operation.....	514
Figure 14.19 EP2 Bulk-Out Transfer Operation .....	515
Figure 14.20 Forcible Stall by Firmware .....	518
Figure 14.21 Automatic Stall by USB Function Module .....	519
Figure 14.22 EP1PKTE Operation in UTRG0.....	521
Figure 14.23 EP2RDFN Operation in UTRG0 .....	522
Figure 14.24 EP1PKTE Operation in UTRG0 (Auto-Request) .....	523
Figure 14.25 EP2RDFN Operation in UTRG0 (Auto-Request) .....	524
Figure 14.26 USB External Circuit in Bus-Powered Mode .....	525
Figure 14.27 USB External Circuit in Self-Powered Mode .....	526
Figure 14.28 Flowchart .....	531
Figure 14.29 Timing Chart.....	532
Figure 14.30 TR Interrupt Flag Set Timing .....	533

## Section 15 A/D Converter

Figure 15.1 Block Diagram of A/D Converter.....	536
Figure 15.2 Access to ADDR (When Reading H'AA40).....	541
Figure 15.3 A/D Conversion Timing (Single-Chip Mode, Channel 1 Selected).....	542
Figure 15.4 A/D Conversion Timing (Scan Mode, Channels AN0 to AN2 Selected) .....	543
Figure 15.5 A/D Conversion Timing .....	544
Figure 15.6 External Trigger Input Timing.....	545
Figure 15.7 A/D Conversion Precision Definitions (1).....	547
Figure 15.8 A/D Conversion Precision Definitions (2).....	547
Figure 15.9 Example of Analog Input Circuit.....	548
Figure 15.10 Analog Input Pin Equivalent Circuit.....	549

## Section 17 Flash Memory (F-ZTAT Version)

Figure 17.1 Block Diagram of Flash Memory .....	554
Figure 17.2 Flash Memory State Transitions .....	555
Figure 17.3 Boot Mode (Sample).....	556
Figure 17.4 User Program Mode (Sample) .....	557
Figure 17.5 Flash Memory Block Configuration (HD64F2218, HD64F2218U, HD64F2218CU, HD64F2212, HD64F2212U, HD64F2212CU).....	558
Figure 17.6 Flash Memory Block Configuration (HD64F2217CU, HD64F2211, HD64F2211U, HD64F2211CU) .....	559
Figure 17.7 Flash Memory Block Configuration (HD64F2210CU) .....	560
Figure 17.8 System Configuration in SCI Boot Mode.....	568
Figure 17.9 System Configuration Diagram when Using USB Boot Mode.....	572
Figure 17.10 Programming/Erasing Flowchart Example in User Program Mode .....	576
Figure 17.11 Flowchart for Flash Memory Emulation in RAM.....	577
Figure 17.12 Example of RAM Overlap Operation .....	578

Figure 17.13 Program/Program-Verify Flowchart.....	580
Figure 17.14 Erase/Erase-Verify Flowchart .....	582
Figure 17.15 Memory Map in Programmer Mode.....	585
Figure 17.16 Power-On/Off Timing (Boot Mode).....	589
Figure 17.17 Power-On/Off Timing (User Program Mode).....	590
Figure 17.18 Mode Transition Timing (Example: Boot Mode → User Mode ↔ User Program Mode).....	591
 <b>Section 18 Masked ROM</b>	
Figure 18.1 Block Diagram of On-Chip Masked ROM (64 kbytes).....	593
 <b>Section 19 Clock Pulse Generator</b>	
Figure 19.1 Block Diagram of Clock Pulse Generator .....	595
Figure 19.2 Connection of Crystal Resonator (Example).....	600
Figure 19.3 Crystal Resonator Equivalent Circuit .....	600
Figure 19.4 External Clock Input (Examples) .....	601
Figure 19.5 External Clock Input Timing.....	602
Figure 19.6 Example Connection of 32.768-kHz Quartz Oscillator.....	603
Figure 19.7 Equivalence Circuit for 32.768-kHz Oscillator .....	603
Figure 19.8 Pin Handling when Subclock Not Required.....	603
Figure 19.9 Example of PLL Circuit .....	604
Figure 19.10 Note on Board Design of Oscillator Circuit .....	605
Figure 19.11 Example of External Clock Switching Circuit .....	606
Figure 19.12 Example of External Clock Switchover Timing.....	606
 <b>Section 20 Power-Down Modes</b>	
Figure 20.1 Mode Transition Diagram .....	609
Figure 20.2 Example of Flash Memory Module Stop Mode Usage .....	616
Figure 20.3 Medium-Speed Mode Transition and Clearance Timing .....	618
Figure 20.4 Software Standby Mode Application Example .....	621
Figure 20.5 Hardware Standby Mode Timing (Example) .....	622
Figure 20.6 Timing of Transition to Hardware Standby Mode .....	622
Figure 20.7 Timing of Recovery from Hardware Standby Mode.....	623
 <b>Section 2 Electrical Characteristics</b>	
Figure 22.1 Power Supply Voltage and Operating Ranges.....	658
Figure 22.2 Output Load Circuit.....	663
Figure 22.3 System Clock Timing.....	665
Figure 22.4 Oscillation Stabilization Timing.....	665
Figure 22.5 Reset Input Timing.....	667
Figure 22.6 Interrupt Input Timing.....	667

Figure 22.7 Basic Bus Timing (Two-State Access) .....	670
Figure 22.8 Basic Bus Timing (Three-State Access) .....	671
Figure 22.9 Basic Bus Timing (Three-State Access with One Wait State).....	672
Figure 22.10 Burst ROM Access Timing (Two-State Access) .....	673
Figure 22.11 External Bus Release Timing .....	674
Figure 22.12 I/O Port Input/Output Timing .....	677
Figure 22.13 TPU Input/Output Timing .....	677
Figure 22.14 TPU Clock Input Timing .....	677
Figure 22.15 SCK Clock Input Timing.....	678
Figure 22.16 SCI Input/Output Timing (Clock Synchronous Mode).....	678
Figure 22.17 A/D Converter External Trigger Input Timing .....	678
Figure 22.18 Boundary Scan TCK Input Timing .....	678
Figure 22.19 Boundary Scan $\overline{\text{TRST}}$ Input Timing (At Reset Hold).....	678
Figure 22.20 Boundary Scan Data Transmission Timing .....	679
Figure 22.21 Data Signal Timing.....	681
Figure 22.22 Test Load Circuit .....	681

## Appendix

Figure C.1 TFP-100G and TFP-100GV Package Dimensions .....	691
Figure C.2 BP-112 and BP-112V Package Dimensions .....	692
Figure C.3 FP-64E and FP-64EV Package Dimensions .....	693
Figure C.4 TNP-64B and TNP-64BV Package Dimensions .....	694



# Tables

<b>Section 1</b>	<b>Overview</b>	
Table 1.1	Pin Functions in Each Operating Mode for H8S/2218 Group.....	15
Table 1.2	Pin Functions in Each Operating Mode for H8S/2212 Group.....	18
<b>Section 2</b>	<b>CPU</b>	
Table 2.1	Instruction Classification.....	46
Table 2.2	Operation Notation.....	47
Table 2.3	Data Transfer Instructions.....	48
Table 2.4	Arithmetic Operations Instructions.....	49
Table 2.5	Logic Operations Instructions.....	50
Table 2.6	Shift Instructions.....	51
Table 2.7	Bit Manipulation Instructions.....	52
Table 2.8	Branch Instructions.....	54
Table 2.9	System Control Instruction.....	55
Table 2.10	Block Data Transfer Instruction.....	56
Table 2.11	Addressing Modes.....	58
Table 2.12	Absolute Address Access Ranges.....	60
Table 2.13	Effective Address Calculation.....	62
<b>Section 3</b>	<b>MCU Operating Modes</b>	
Table 3.1	MCU Operating Mode Selection.....	71
Table 3.2	Pin Functions in Each Operating Mode.....	76
<b>Section 4</b>	<b>Exception Handling</b>	
Table 4.1	Exception Types and Priority.....	81
Table 4.2	Exception Handling Vector Table.....	82
Table 4.3	Reset Types.....	84
Table 4.4	Status of CCR and EXR after Trace Exception Handling.....	87
Table 4.5	Status of CCR and EXR after Trap Instruction Exception Handling.....	88
<b>Section 5</b>	<b>Interrupt Controller</b>	
Table 5.1	Pin Configuration.....	93
Table 5.2	Interrupt Sources, Vector Addresses, and Interrupt Priorities.....	101
Table 5.3	Interrupt Control Modes.....	103
Table 5.4	Interrupt Response Times.....	108
Table 5.5	Number of States in Interrupt Handling Routine Execution Statuses.....	109
Table 5.6	Interrupt Source Selection and Clearing Control.....	111

## Section 6 Bus Controller

Table 6.1	Pin Configuration.....	117
Table 6.2	Bus Specifications for Each Area (Basic Bus Interface) .....	129
Table 6.3	Data Buses Used and Valid Strokes.....	135
Table 6.4	Pin States in Idle Cycle.....	152
Table 6.5	Pin States in Bus Released State.....	153

## Section 7 DMA Controller (DMAC)

Table 7.1	Short Address Mode and Full Address Mode (For 1 Channel: Example of Channel 0).....	160
Table 7.2	DMAC Transfer Modes.....	177
Table 7.3	Register Functions in Sequential Mode.....	178
Table 7.4	Register Functions in Idle Mode.....	181
Table 7.5	Register Functions in Repeat Mode.....	183
Table 7.6	Register Functions in Normal Mode.....	186
Table 7.7	Register Functions in Block Transfer Mode.....	189
Table 7.8	DMAC Activation Sources.....	194
Table 7.9	DMAC Channel Priority Order.....	202
Table 7.10	Interrupt Source Priority Order.....	206

## Section 8 I/O Ports

Table 8.1	Port Functions of H8S/2218 Group.....	211
Table 8.2	Port Functions of H8S/2212 Group.....	214
Table 8.3	P17 Pin Function.....	218
Table 8.4	P16 Pin Function.....	218
Table 8.5	P15 Pin Function.....	218
Table 8.6	P14 Pin Function.....	219
Table 8.7	P13 Pin Function.....	219
Table 8.8	P12 Pin Function.....	219
Table 8.9	P11 Pin Function.....	220
Table 8.10	P10 Pin Function.....	220
Table 8.11	P17 Pin Function.....	220
Table 8.12	P16 Pin Function.....	221
Table 8.13	P15 Pin Function.....	221
Table 8.14	P14 Pin Function.....	221
Table 8.15	P13 Pin Function.....	222
Table 8.16	P12 Pin Function.....	222
Table 8.17	P11 Pin Function.....	222
Table 8.18	P10 Pin Function.....	222
Table 8.19	P36 Pin Function.....	225
Table 8.20	P32 Pin Function.....	226

Table 8.21	P31 Pin Function .....	226
Table 8.22	P30 Pin Function .....	226
Table 8.23	P74 Pin Function .....	231
Table 8.24	P71 Pin Function .....	231
Table 8.25	P70 Pin Function .....	231
Table 8.26	P77 Pin Function .....	231
Table 8.27	P76 Pin Function .....	232
Table 8.28	P75 Pin Function .....	232
Table 8.29	PA3 Pin Function .....	236
Table 8.30	PA2 Pin Function .....	236
Table 8.31	PA1 Pin Function .....	237
Table 8.32	PA0 Pin Function .....	237
Table 8.33	PA3 Pin Function .....	237
Table 8.34	PA2 Pin Function .....	238
Table 8.35	PA1 Pin Function .....	238
Table 8.36	Input Pull-Up MOS States (Port A).....	238
Table 8.37	PB7 Pin Function .....	242
Table 8.38	PB6 Pin Function .....	242
Table 8.39	PB5 Pin Function .....	242
Table 8.40	PB4 Pin Function .....	243
Table 8.41	PB3 Pin Function .....	243
Table 8.42	PB2 Pin Function .....	243
Table 8.43	PB1 Pin Function .....	243
Table 8.44	PB0 Pin Function .....	244
Table 8.45	Input Pull-Up MOS States (Port B).....	244
Table 8.46	PC7 Pin Function .....	247
Table 8.47	PC6 Pin Function .....	247
Table 8.48	PC5 Pin Function .....	248
Table 8.49	PC4 Pin Function .....	248
Table 8.50	PC3 Pin Function .....	248
Table 8.51	PC2 Pin Function .....	248
Table 8.52	PC1 Pin Function .....	248
Table 8.53	PC0 Pin Function .....	249
Table 8.54	Input Pull-Up MOS States (Port C).....	249
Table 8.55	PD7 Pin Function .....	252
Table 8.56	PD6 Pin Function .....	252
Table 8.57	PD5 Pin Function .....	252
Table 8.58	PD4 Pin Function .....	253
Table 8.59	PD3 Pin Function .....	253
Table 8.60	PD2 Pin Function .....	253
Table 8.61	PD1 Pin Function .....	253

Table 8.62	PD0 Pin Function.....	253
Table 8.63	Input Pull-Up MOS States (Port D).....	254
Table 8.64	PE7 Pin Function.....	257
Table 8.65	PE6 Pin Function.....	257
Table 8.66	PE5 Pin Function.....	258
Table 8.67	PE4 Pin Function.....	258
Table 8.68	PE3 Pin Function.....	258
Table 8.69	PE2 Pin Function.....	258
Table 8.70	PE1 Pin Function.....	259
Table 8.71	PE0 Pin Function.....	259
Table 8.72	PE7 Pin Function.....	259
Table 8.73	PE6 Pin Function.....	259
Table 8.74	PE5 Pin Function.....	259
Table 8.75	PE4 Pin Function.....	260
Table 8.76	PE3 Pin Function.....	260
Table 8.77	PE2 Pin Function.....	260
Table 8.78	PE1 Pin Function.....	260
Table 8.79	PE0 Pin Function.....	260
Table 8.80	Input Pull-Up MOS States (Port E).....	261
Table 8.81	PF7 Pin Function.....	264
Table 8.82	PF6 Pin Function.....	264
Table 8.83	PF5 Pin Function.....	265
Table 8.84	PF4 Pin Function.....	265
Table 8.85	PF3 Pin Function.....	265
Table 8.86	PF2 Pin Function.....	265
Table 8.87	PF1 Pin Function.....	266
Table 8.88	PF0 Pin Function.....	266
Table 8.89	PF7 Pin Function.....	266
Table 8.90	PF3 Pin Function.....	267
Table 8.91	PF0 Pin Function.....	267
Table 8.92	PG4 Pin Function.....	270
Table 8.93	PG3 Pin Function.....	270
Table 8.94	PG2 Pin Function.....	270
Table 8.95	PG1 Pin Function.....	270
Table 8.96	PG1 Pin Function.....	271
Table 8.97	PG0 Pin Function.....	271
Table 8.98	Examples of Ways to Handle Unused Input Pins.....	272

## Section 9 16-Bit Timer Pulse Unit (TPU)

Table 9.1	TPU Functions.....	275
Table 9.2	Pin Configuration.....	277

Table 9.3	CCLR2 to CCLR0 (channel 0).....	280
Table 9.4	CCLR2 to CCLR0 (channels 1 and 2).....	280
Table 9.5	TPSC2 to TPSC0 (channel 0).....	281
Table 9.6	TPSC2 to TPSC0 (channel 1).....	281
Table 9.7	TPSC2 to TPSC0 (channel 2).....	282
Table 9.8	MD3 to MD0.....	283
Table 9.9	TIORH_0 (channel 0).....	285
Table 9.10	TIORH_0 (channel 0).....	286
Table 9.11	TIORL_0 (channel 0).....	287
Table 9.12	TIORL_0 (channel 0).....	288
Table 9.13	TIOR_1 (channel 1).....	289
Table 9.14	TIOR_1 (channel 1).....	290
Table 9.15	TIOR_2 (channel 2).....	291
Table 9.16	TIOR_2 (channel 2).....	292
Table 9.17	Register Combinations in Buffer Operation.....	309
Table 9.18	PWM Output Registers and Output Pins.....	314
Table 9.19	Phase Counting Mode Clock Input Pins.....	317
Table 9.20	Up/Down-Count Conditions in Phase Counting Mode 1.....	318
Table 9.21	Up/Down-Count Conditions in Phase Counting Mode 2.....	319
Table 9.22	Up/Down-Count Conditions in Phase Counting Mode 3.....	320
Table 9.23	Up/Down-Count Conditions in Phase Counting Mode 4.....	321
Table 9.24	TPU Interrupts.....	322
<b>Section 10 Watchdog Timer (WDT)</b>		
Table 10.1	WDT Interrupt Source.....	345
<b>Section 11 Realtime Clock (RTC)</b>		
Table 11.1	Pin Configuration.....	350
Table 11.2	Interrupt Source.....	360
Table 11.3	Operating State in Each Mode.....	362
<b>Section 12 Serial Communication Interface</b>		
Table 12.1	Pin Configuration.....	367
Table 12.2	Relationships between the N Setting in BRR and Bit Rate B.....	395
Table 12.3	BRR Settings for Various Bit Rates (Asynchronous Mode).....	396
Table 12.4	Maximum Bit Rate for Each Frequency (Asynchronous Mode).....	399
Table 12.5	Maximum Bit Rate with External Clock Input (Asynchronous Mode).....	400
Table 12.6	BRR Settings for Various Bit Rates (Clocked Synchronous Mode).....	401
Table 12.7	Maximum Bit Rate with External Clock Input (Clocked Synchronous Mode).....	401
Table 12.8	BRR Settings for Various Bit Rates (Smart Card Interface Mode, when n = 0 and S = 372).....	402

Table 12.9	Maximum Bit Rate at Various Frequencies (Smart Card Interface Mode).....	402
Table 12.10	Serial Transfer Formats (Asynchronous Mode).....	404
Table 12.11	SSR Status Flags and Receive Data Handling.....	411
Table 12.12	SCI Interrupt Sources.....	440
Table 12.13	Interrupt Sources in Smart Card Interface Mode.....	441

## Section 13 Boundary Scan Function

Table 13.1	Pin Configuration.....	451
Table 13.2	Instruction Configuration.....	452
Table 13.3	IDCODE Register Configuration.....	454
Table 13.4	Correspondence between LSI Pins and Boundary Scan Register.....	455

## Section 14 Universal Serial Bus (USB)

Table 14.1	Pin Configuration.....	467
Table 14.2	Relationship between UTSTR0 Setting and Pin Output.....	490
Table 14.3	Relationship between Pin Input and UTSTR1 Monitoring Value.....	491
Table 14.4	Interrupt Sources.....	495
Table 14.5	Command Decoding by Firmware.....	516

## Section 15 A/D Converter

Table 15.1	Pin Configuration.....	537
Table 15.2	Analog Input Channels and Corresponding ADDR Registers.....	538
Table 15.3	A/D Conversion Time (Single Mode).....	545
Table 15.4	A/D Conversion Time (Scan Mode).....	545
Table 15.5	A/D Converter Interrupt Source.....	546
Table 15.6	Analog Pin Specifications.....	549

## Section 17 Flash Memory (F-ZTAT Version)

Table 17.1	Differences between Boot Mode and User Program Mode.....	555
Table 17.2	Pin Configuration.....	561
Table 17.3	Setting On-Board Programming Modes.....	567
Table 17.4	Boot Mode Operation.....	570
Table 17.5	System Clock Frequencies for which Automatic Adjustment of LSI Bit Rate Is Possible.....	570
Table 17.6	Enumeration Information.....	571
Table 17.7	USB Boot Mode Operation.....	574
Table 17.8	Flash Memory Operating States.....	586
Table 17.9	Registers Present in F-ZTAT Version but Absent in Masked ROM Version.....	592

## Section 19 Clock Pulse Generator

Table 19.1	Damping Resistance Value.....	600
------------	-------------------------------	-----

Table 19.2	Crystal Resonator Characteristics.....	600
Table 19.3	External Clock Input Conditions.....	601
Table 19.4	External Clock Input Conditions when Duty Adjustment Circuit Is not Used.....	602

## Section 20 Power-Down Modes

Table 20.1	LSI Internal States in Each Mode.....	608
Table 20.2	Transition Conditions of Power-Down Modes.....	610
Table 20.3	Oscillation Stabilization Time Settings.....	620
Table 20.4	$\phi$ Pin State in Each Processing State.....	627

## Section 22 Electrical Characteristics

Table 22.1	Absolute Maximum Ratings.....	657
Table 22.2	DC Characteristics.....	659
Table 22.3	Permissible Output Currents.....	662
Table 22.4	Clock Timing.....	664
Table 22.5	Control Signal Timing.....	666
Table 22.6	Bus Timing.....	668
Table 22.7	Timing of On-Chip Supporting Modules.....	675
Table 22.8	USB Characteristics (USD+ and USD- pins) when On-Chip USB Transceiver Is Used.....	680
Table 22.9	A/D Conversion Characteristics.....	682
Table 22.10	Flash Memory Characteristics.....	683





# Section 1 Overview

## 1.1 Overview

- High-speed H8S/2000 central processing unit with 16-bit architecture
  - Upward-compatible with H8/300 and H8/300H CPUs on an object level
  - Sixteen 16-bit general registers
  - 65 basic instructions
- Various peripheral functions
  - DMA controller (DMAC)
  - 16-bit timer-pulse unit (TPU)
  - Watchdog timer (WDT)
  - Realtime clock (RTC)
  - Serial communication interface (SCI)
  - Boundary scan
  - Universal serial bus (USB)
  - 10-bit A/D converter
  - High-performance user debugging interface (H-UDI)
  - Clock pulse generator
- On-chip memory
  - H8S/2218 Group

ROM	Part No.	ROM	RAM	Remarks
Flash memory Version	HD64F2218	128 kbytes	12 kbytes	SCI boot mode
	HD64F2218U	128 kbytes	12 kbytes	USB boot mode
	HD64F2218CU	128 kbytes	12 kbytes	USB boot mode
	HD64F2217CU	64 kbytes	12 kbytes	USB boot mode
Masked ROM Version	HD6432217	64 kbytes	8 kbytes	—

## H8S/2212 Group

ROM	Part No.	ROM	RAM	Remarks
Flash memory Version	HD64F2212	128 kbytes	12 kbytes	SCI boot mode
	HD64F2212U	128 kbytes	12 kbytes	USB boot mode
	HD64F2212CU	128 kbytes	12 kbytes	USB boot mode
	HD64F2211	64 kbytes	8 kbytes	SCI boot mode
	HD64F2211U	64 kbytes	8 kbytes	USB boot mode
	HD64F2211CU	64 kbytes	8 kbytes	USB boot mode
	HD64F2210CU	32 kbytes	8 kbytes	USB boot mode
Masked ROM Version	HD6432211	64 kbytes	8 kbytes	—
	HD6432210	32 kbytes	4 kbytes	—
	HD6432210S	32 kbytes	4 kbytes	—

- General I/O ports

I/O pins: 69 for the H8S/2218 Group, 37 for the H8S/2212 Group

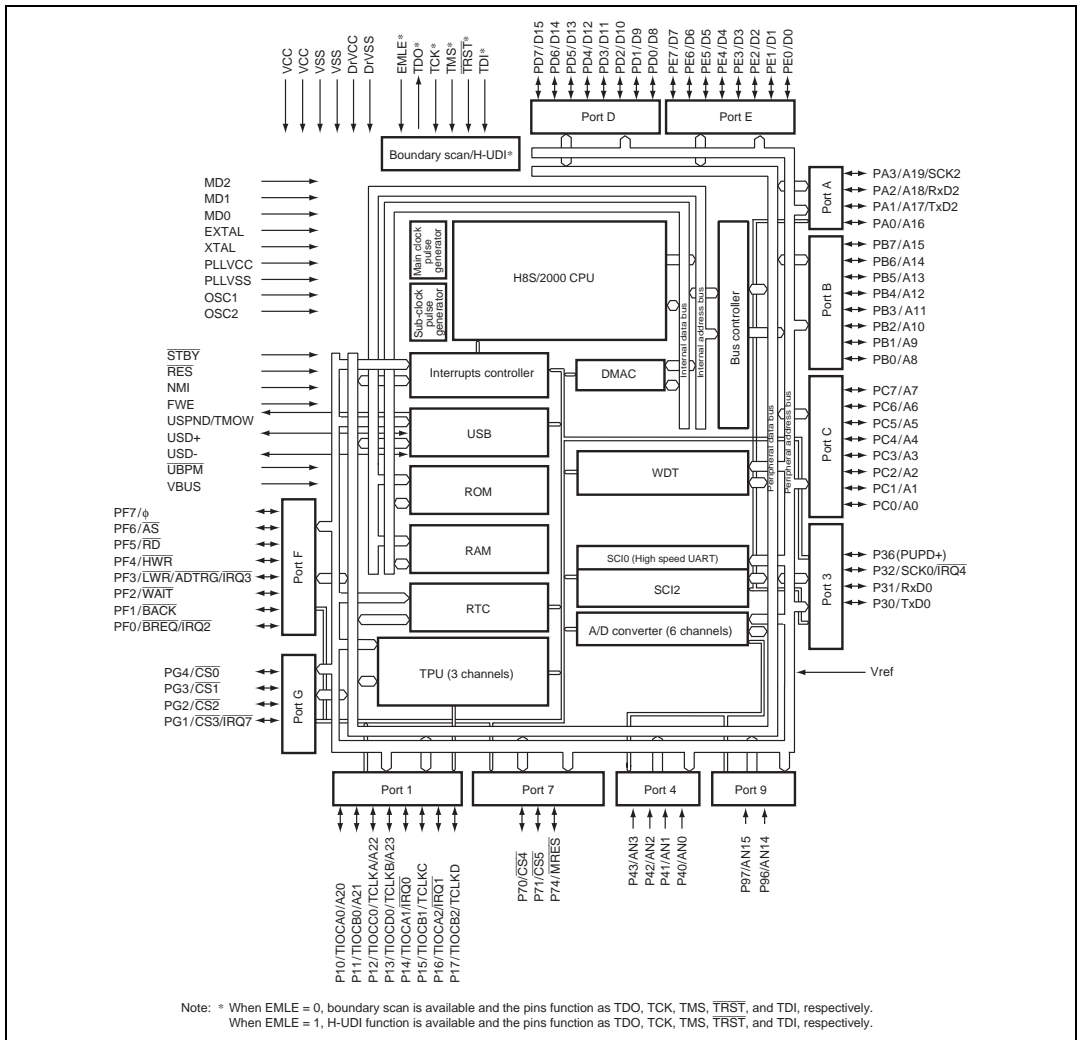
- Supports various power-down states
- Compact package

Package	Code*	Body Size	Pin Pitch	Remarks
TQFP-100	TFP-100G, TFP-100GV	12.0 × 12.0 mm	0.4 mm	H8S/2218 Group
P-LFBGA-112	BP-112, BP-112V	10.0 × 10.0 mm	0.8 mm	
LQFP-64	FP-64E, FP-64EV	10.0 × 10.0 mm	0.5 mm	H8S/2212 Group
VQFN-64	TNP-64B, TNP-64BV	8.0 × 8.0 mm	0.4 mm	

Note: \* A V appended to the end of the package code indicates a lead-free version.

## 1.2 Internal Block Diagram

The internal block diagram of the HD64F2218, HD64F2218U, HD64F2218CU and HD64F2217CU is shown in figure 1.1. The internal block diagram of the HD6432217 is shown in figure 1.2. The internal block diagram of the HD64F2212, HD64F2212U, HD64F2212CU, HD64F2211, HD64F2211U, HD64F2211CU and HD64F2210CU is shown in figure 1.3. The internal block diagram of the HD6432211, HD6432210 and HD6432210S is shown in figure 1.4.



**Figure 1.1 Internal Block Diagram of HD64F2218, HD64F2218U, HD64F2218CU and HD642217CU**

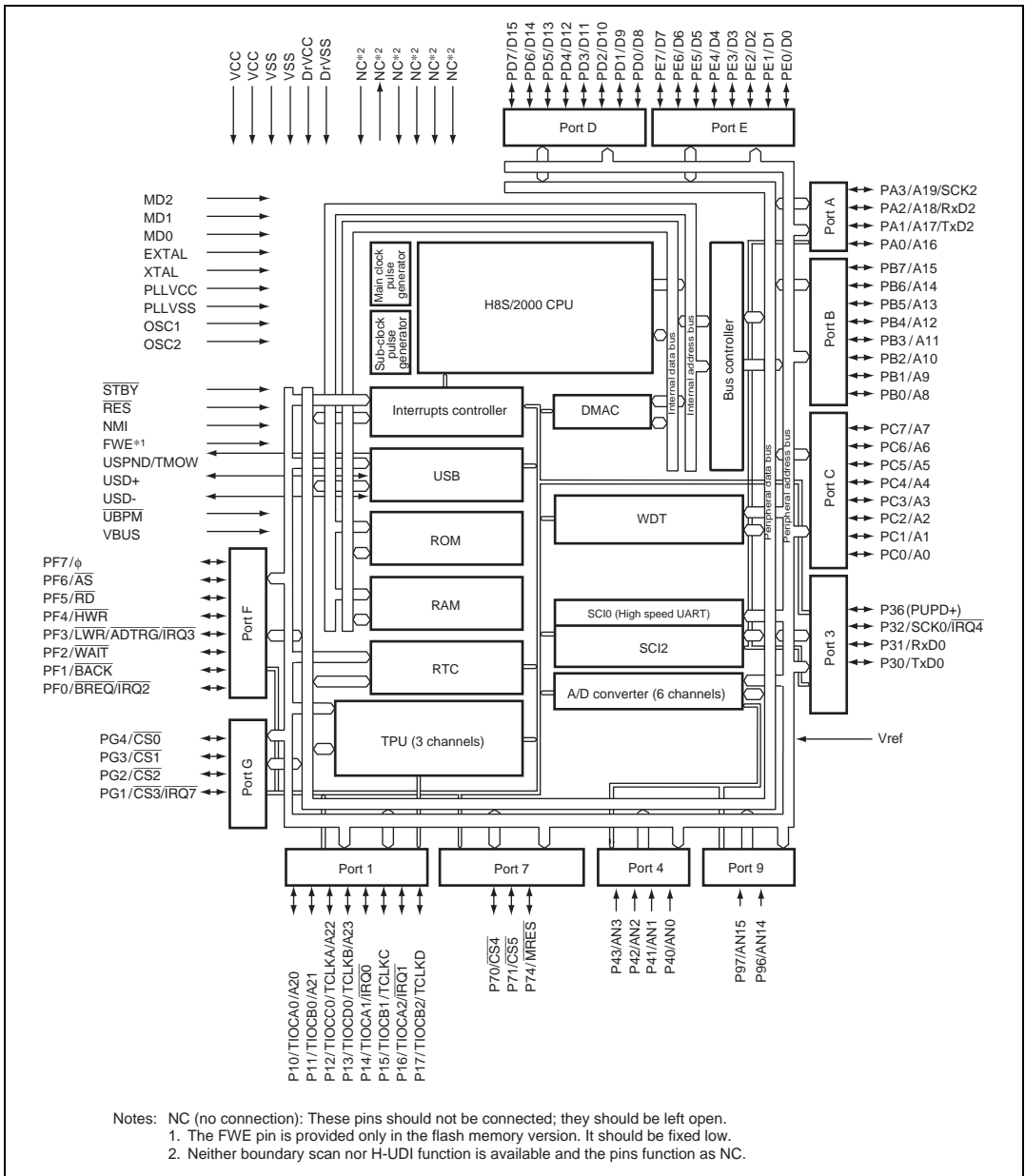
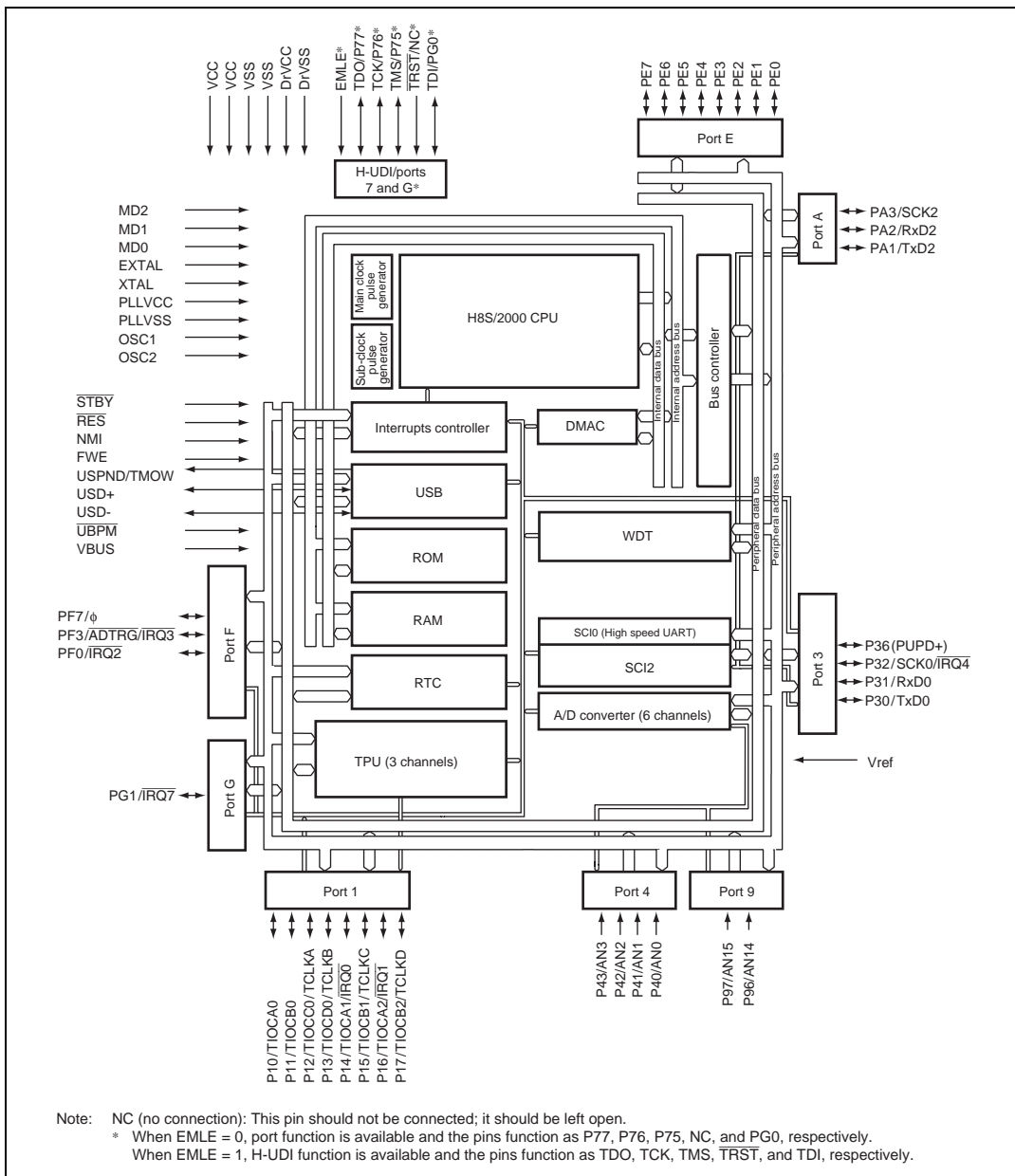


Figure 1.2 Internal Block Diagram of HD6432217



**Figure 1.3 Internal Block Diagram of HD64F2212, HD64F2212U, HD64F2212CU, HD64F2211, HD64F2211U, HD64F2211CU and HD64F2210CU**

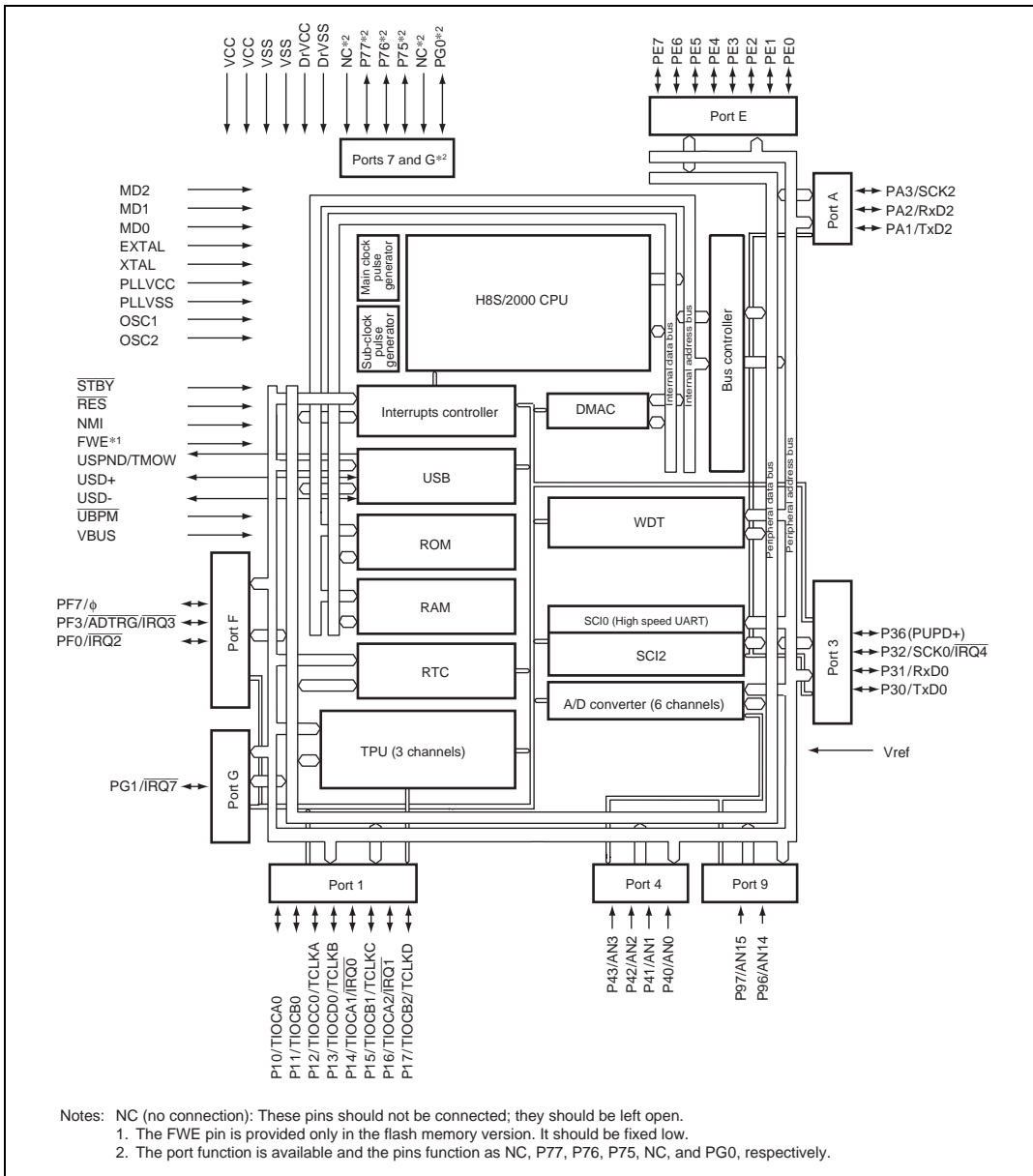
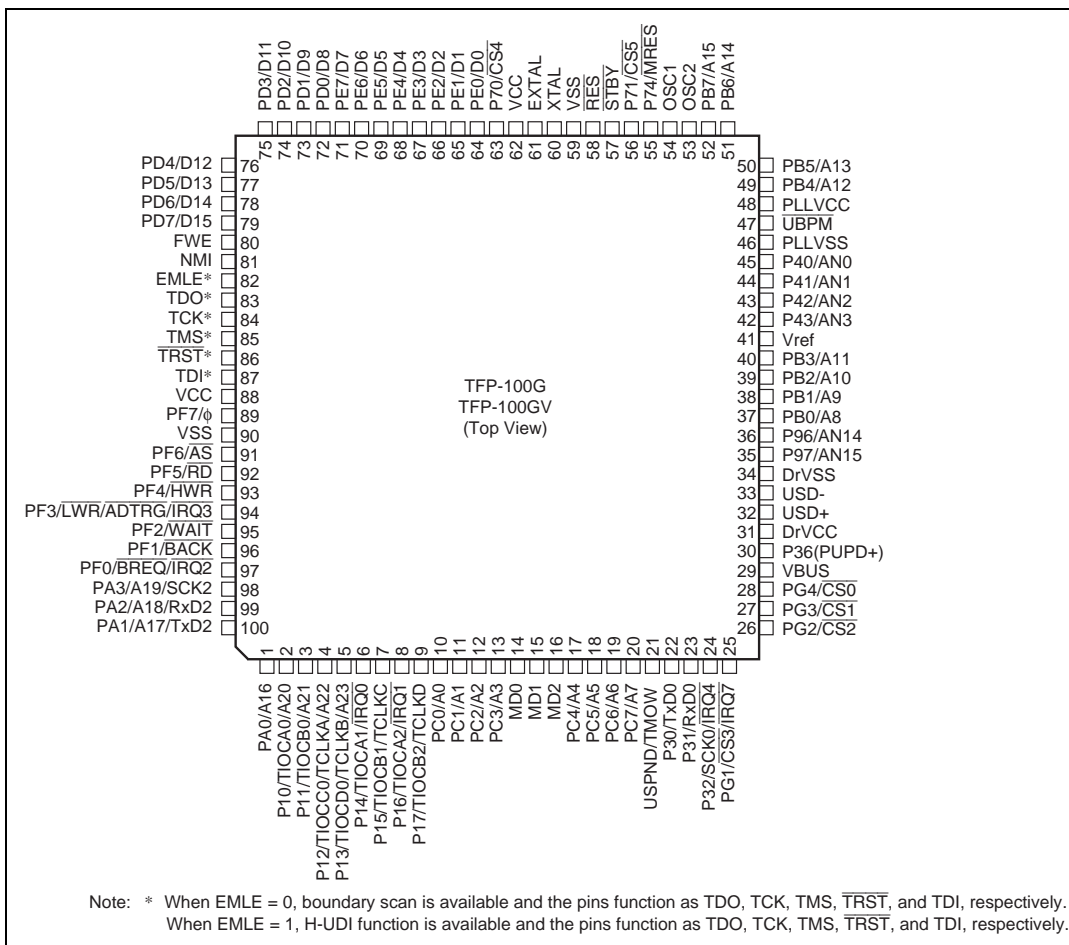


Figure 1.4 Internal Block Diagram of HD6432211, HD6432210 and HD6432210S

### 1.3 Pin Arrangements

The pin arrangements of the HD64F2218, HD64F2218U, HD64F2218CU and HD64F2217CU are shown in figures 1.5 and 1.6. The pin arrangements of the HD6432217 are shown in figures 1.7 and 1.8. The pin arrangements of the HD64F2212, HD64F2212U, HD64F2212CU, HD64F2211, HD64F2211U, HD64F2211CU and HD64F2210CU are shown in figures 1.9 and 1.11. The pin arrangements of the HD6432211, HD6432210 and HD6432210S is shown in figures 1.10 and 1.12.



**Figure 1.5 Pin Arrangements of HD64F2218, HD64F2218U, HD64F2218CU and HD64F2217CU (TFP-100G, TFP-100GV)**

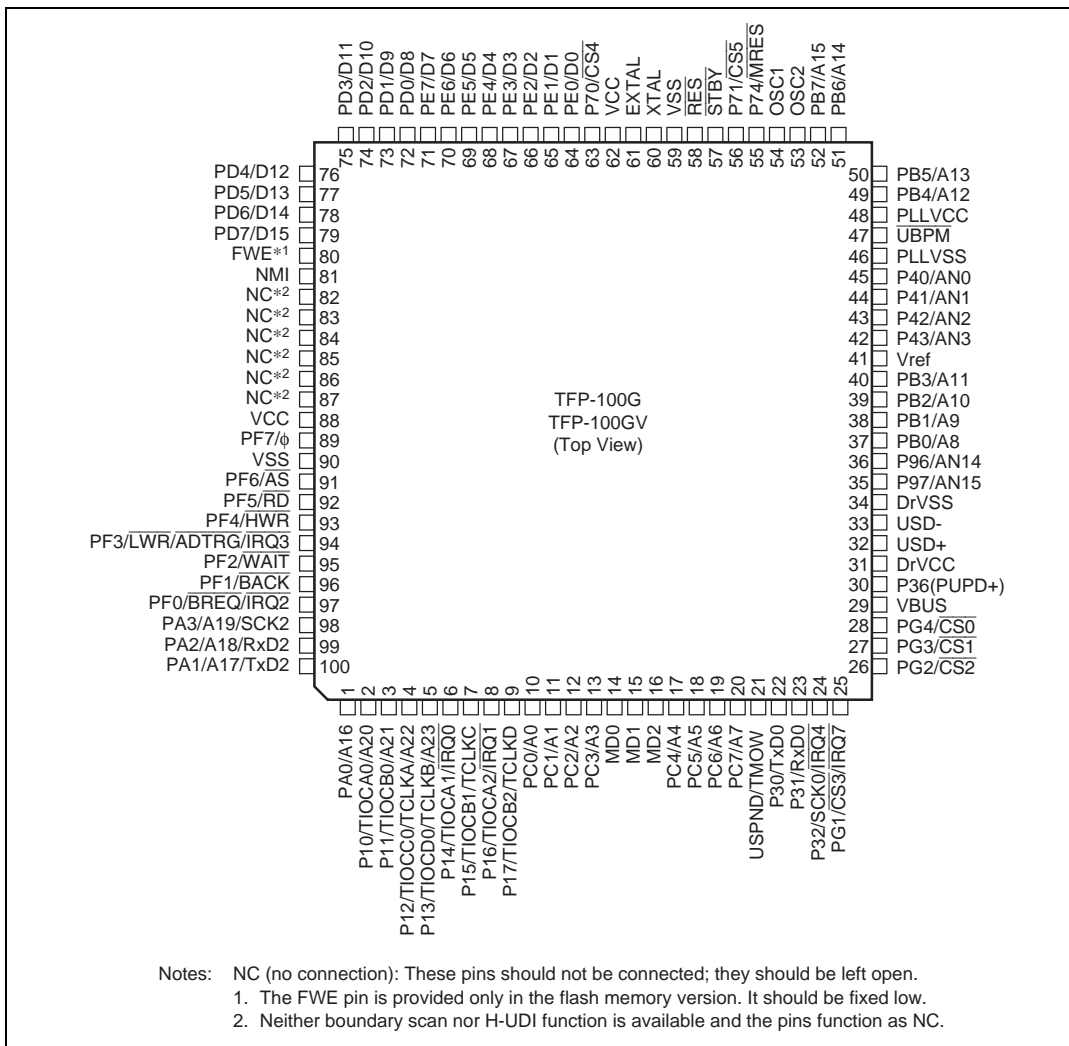
	A	B	C	D	E	F	G	H	J	K	L
11	NC	PD3/D11	PD0/D8	PE5/D5	PE2/D2	P70/ $\overline{CS4}$	XTAL	$\overline{STBY}$	OSC1	PB7/A15	NC
10	PD5/D13	PD4/D12	PD2/D10	PE7/D7	PE3/D3	PE0/D0	EXTAL	P71/ $\overline{CS5}$	OSC2	PB6/A14	PB5/A13
9	FWE	PD7/D15	NC	PD1/D9	PE4/D4	VCC	VSS	P74/ $\overline{MRES}$	NC	PB4/A12	$\overline{UBPM}$
8	TDO*	EMLE*	NMI	PD6/D14	PE6/D6	PE1/D1	$\overline{RES}$	NC	PLLVCC	PLLVSS	P41/AN1
7	$\overline{TRST}^*$	TDI*	TMS*	TCK*	BP-112 BP-112V (Top view)			P40/AN0	P42/AN2	P43/AN3	NC
6	PF7/ $\phi$	VSS	VCC	PF6/ $\overline{AS}$				Vref	PB1/A9	PB3/A11	PB2/A10
5	PF5/ $\overline{RD}$	PF4/ $\overline{HWR}$	PF3/ $\overline{LWR}$ / ADTRG/ IRQ3	PF1/ $\overline{BACK}$				DrVSS	P97/ AN15	PB0/A8	P96/ AN14
4	PF2/ $\overline{WAIT}$	PF0/ $\overline{BREQ}$ / IRQ2	PA2/A18/ RxD2	P11/ TIOCB0/ A21	P17/ TIOCB2/ TCLKD	MD2	USPND/ TMOW	PG4/ $\overline{CS0}$	DrVCC	USD+	USD-
3	PA3/A19/ SCK2	PA1/A17/ TxD2	NC	P14/ TIOCA1/ IRQ0	PC0/A0	PC3/A3	PC6/A6	P32/ SCK0/ IRQ4	NC	VBUS	P36 (PUDP+)
2	NC	PA0/A16	P12/ TIOCC0/ TCLKA/ A22	P15/ TIOCB1/ TCLKC	PC2/A2	MD1	PC5/A5	P30/TxD0	PG1/ $\overline{CS3}$ / IRQ7	PG2/ $\overline{CS2}$	PG3/ $\overline{CS1}$
1	NC	P10/ TIOCA0/ A20	P13/ TIOCD0/ TCLKB/ A23	P16/ TIOCA2/ IRQ1	PC1/A1	MD0	PC4/A4	PC7/A7	P31/RxD0	NC	NC
	A	B	C	D	E	F	G	H	J	K	L

INDEX ↗

Notes: NC (no connection): These pins should not be connected; they should be left open.  
 \* When EMLE = 0, boundary scan is available and the pins function as TDO, TCK, TMS, TRST, and TDI, respectively.  
 When EMLE = 1, H-UDI function is available and the pins function as TDO, TCK, TMS,  $\overline{TRST}$ , and TDI, respectively.

**Figure 1.6 Pin Arrangements of HD64F2218, HD64F2218U, HD64F2218CU and HD64F2217CU (BP-112, BP-112V)**





Notes: NC (no connection): These pins should not be connected; they should be left open.

1. The FWE pin is provided only in the flash memory version. It should be fixed low.

2. Neither boundary scan nor H-UDI function is available and the pins function as NC.

**Figure 1.7 Pin Arrangements of HD6432217 (TFP-100G, TFP-100GV)**

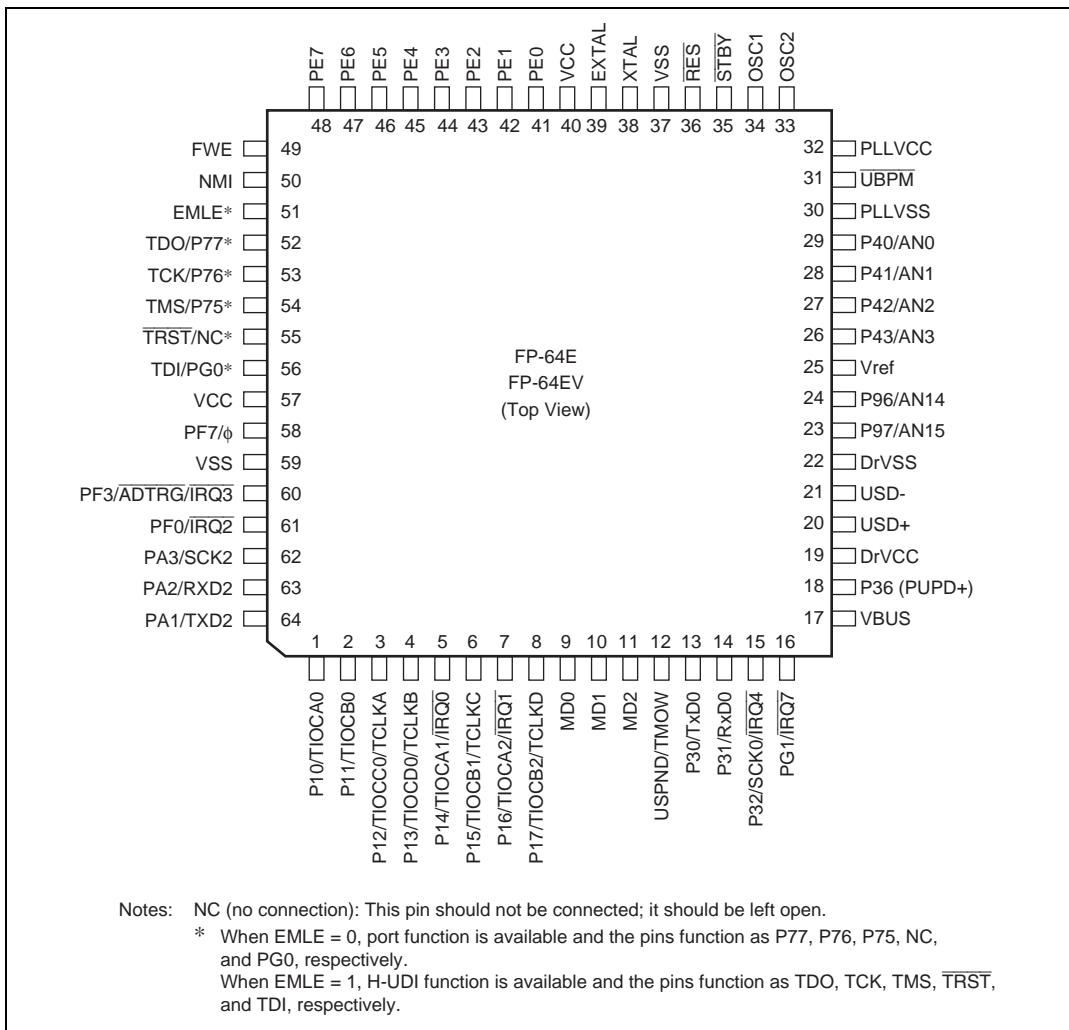
	A	B	C	D	E	F	G	H	J	K	L		
11	NC	PD3/D11	PD0/D8	PE5/D5	PE2/D2	P70/ $\overline{CS4}$	XTAL	$\overline{STBY}$	OSC1	PB7/A15	NC		
10	PD5/D13	PD4/D12	PD2/D10	PE7/D7	PE3/D3	PE0/D0	EXTAL	P71/ $\overline{CS5}$	OSC2	PB6/A14	PB5/A13		
9	FWE <sup>*1</sup>	PD7/D15	NC	PD1/D9	PE4/D4	VCC	VSS	P74/ MRES	NC	PB4/A12	$\overline{UBPM}$		
8	NC <sup>*2</sup>	NC <sup>*2</sup>	NMI	PD6/D14	PE6/D6	PE1/D1	$\overline{RES}$	NC	PLLVCC	PLLVSS	P41/AN1		
7	NC <sup>*2</sup>	NC <sup>*2</sup>	NC <sup>*2</sup>	NC <sup>*2</sup>	BP-112 BP-112V (Top view)			P40/AN0	P42/AN2	P43/AN3	NC		
6	PF7/ $\phi$	VSS	VCC	PF6/ $\overline{AS}$				Vref	PB1/A9	PB3/A11	PB2/A10		
5	PF5/ $\overline{RD}$	PF4/ $\overline{HWR}$	PF3/ $\overline{LWR}$ / ADTRG/ IRQ3	PF1/ BACK				DrVSS	P97/ AN15	PB0/A8	P96/ AN14		
4	PF2/ $\overline{WAIT}$	PF0/ $\overline{BREQ}$ / IRQ2	PA2/A18/ RxD2	P11/ TIOCB0/ A21	P17/ TIOCB2/ TCLKD	MD2	USPND/ TMOW	PG4/ $\overline{CS0}$	DrVCC	USD+	USD-		
3	PA3/A19/ SCK2	PA1/A17/ TxD2	NC	P14/ TIOCA1/ IRQ0	PC0/A0	PC3/A3	PC6/A6	P32/ SCK0/ IRQ4	NC	VBUS	P36 (PUDP+)		
2	NC	PA0/A16	P12/ TIOCC0/ TCLKA/ A22	P15/ TIOCB1/ TCLKC	PC2/A2	MD1	PC5/A5	P30/TxD0	PG1/ CS3/ IRQ7	PG2/ $\overline{CS2}$	PG3/ $\overline{CS1}$		
1	NC	P10/ TIOCA0/ A20	P13/ TIOCD0/ TCLKB/ A23	P16/ TIOCA2/ IRQ1	PC1/A1	MD0	PC4/A4	PC7/A7	P31/RxD0	NC	NC		
	A	B	C	D	E	F	G	H	J	K	L		

INDEX

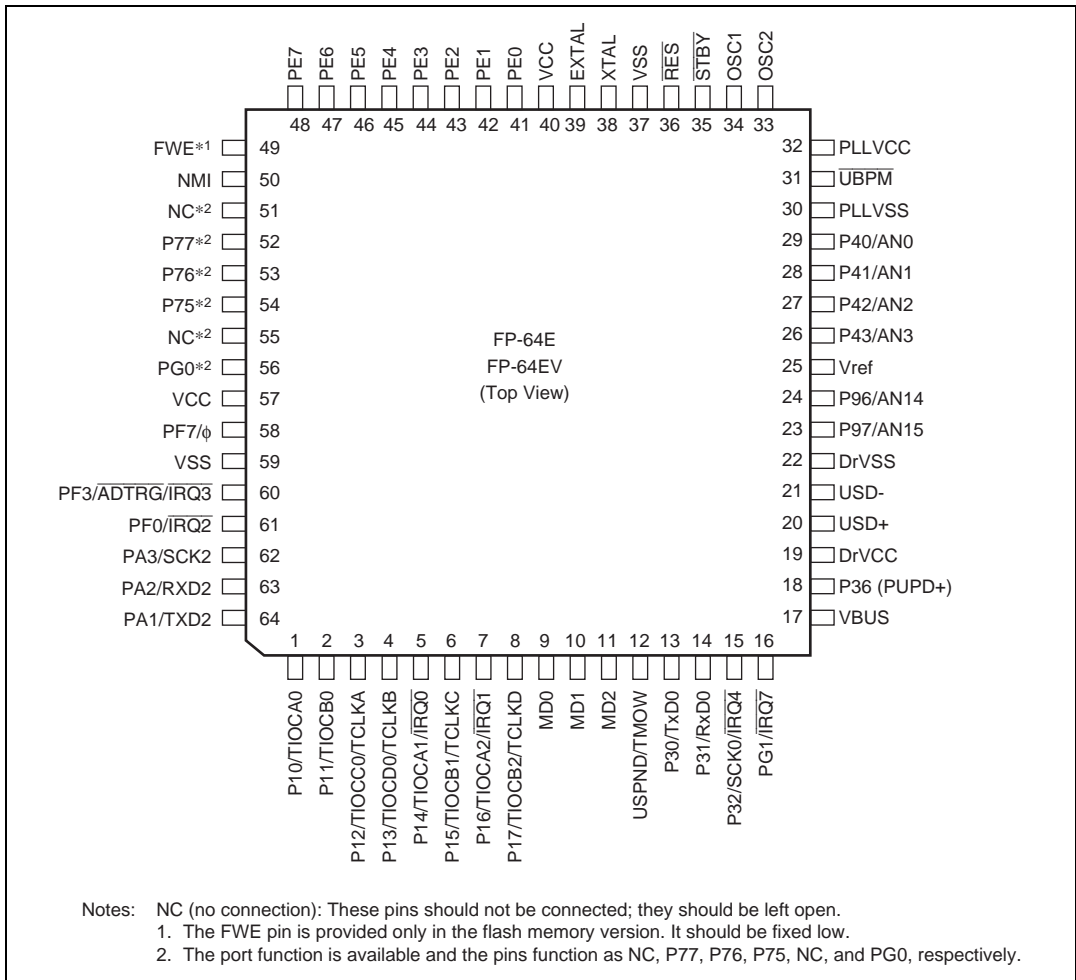
Notes: NC (no connection): These pins should not be connected; they should be left open.

1. The FWE pin is provided only in the flash memory version. It should be fixed low.
2. Neither boundary scan nor H-UDI function is available and the pins function as NC.

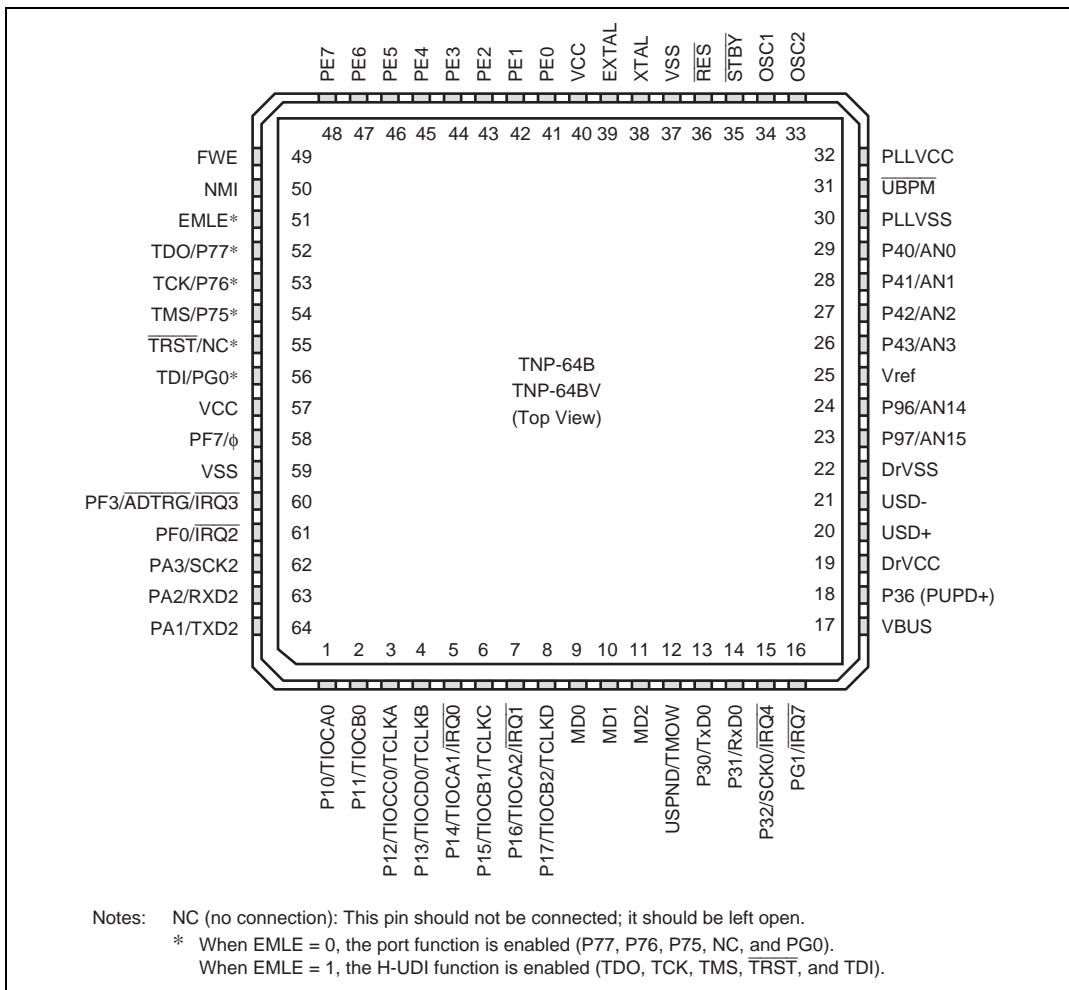
**Figure 1.8 Pin Arrangements of HD6432217 (BP-112, BP-112V)**



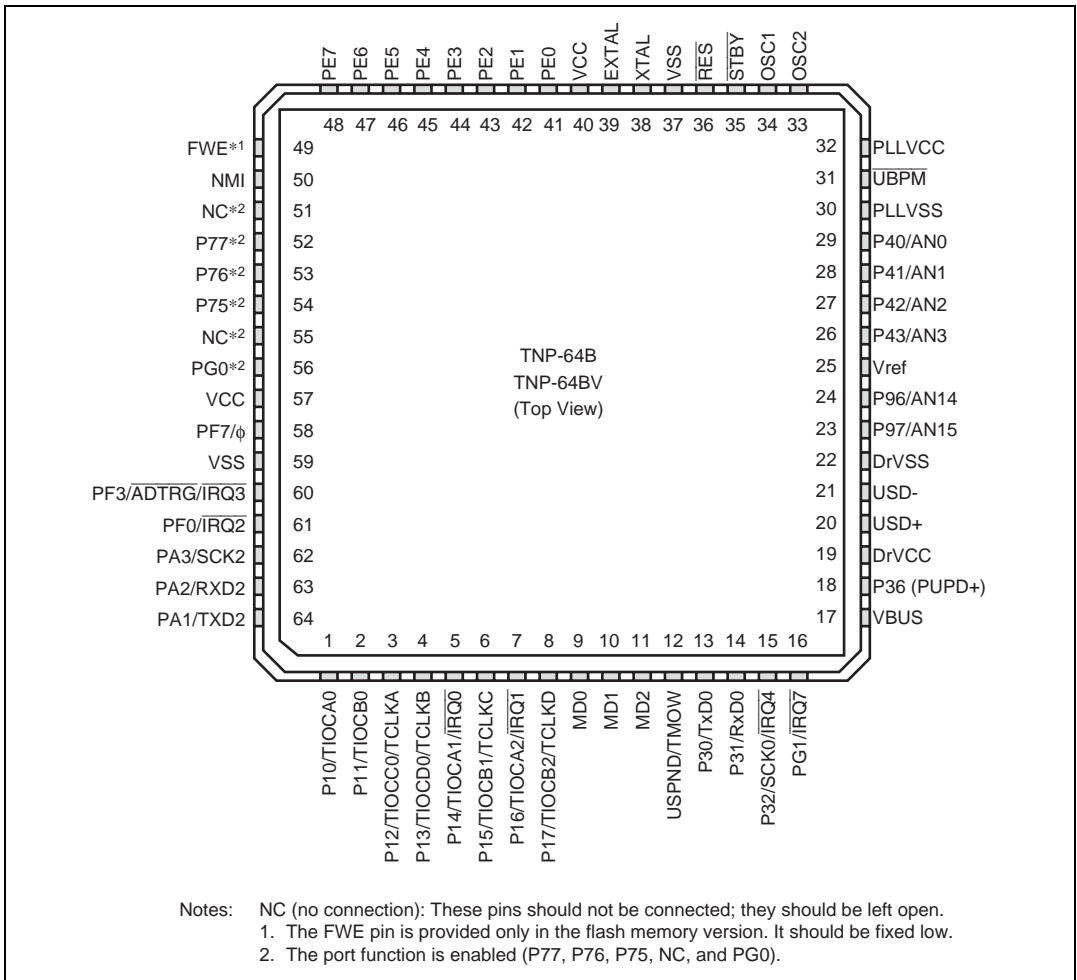
**Figure 1.9 Pin Arrangements of HD64F2212, HD64F2212U, HD64F2212CU, HD64F2211, HD64F2211U, HD64F2211CU and HD64F2210CU (FP-64E, FP-64EV)**



**Figure 1.10 Pin Arrangements of HD6432211, HD6432210 and HD6432210S (FP-64E, FP-64EV)**



**Figure 1.11 Pin Arrangements of HD64F2212, HD64F2212U, HD64F2212CU, HD64F2211, HD64F2211U, HD64F2211CU and HD64F2210CU (TNP-64B, TNP-64BV)**



**Figure 1.12 Pin Arrangements of HD6432211, HD6432210 and HD6432210S (TNP-64B, TNP-64BV)**

## 1.4 Pin Functions in Each Operating Mode

Table 1.1 shows the pin functions in each operating mode for the H8S/2218 Group, and table 1.2 shows that for the H8S/2212 Group.

**Table 1.1 Pin Functions in Each Operating Mode for H8S/2218 Group**

Pin No.	Pin Name*					Programmer Mode
	TFP-100G, BP-112, TFP-100GV BP-112V	Modes 4, 5	Mode 6	Mode 7		
1	B2	PA0/A16	PA0/A16	PA0		NC
2	B1	P10/TIOCA0/A20	P10/TIOCA0/A20	P10/TIOCA0		A2
3	D4	P11/TIOCB0/A21	P11/TIOCB0/A21	P11/TIOCB0		A3
4	C2	P12/TIOCC0/TCLKA/A22	P12/TIOCC0/TCLKA/A22	P12/TIOCC0/TCLKA		A4
5	C1	P13/TIOCD0/TCLKB/A23	P13/TIOCD0/TCLKB/A23	P13/TIOCD0/TCLKB		A5
6	D3	P14/TIOCA1/ $\overline{\text{IRQ0}}$	P14/TIOCA1/ $\overline{\text{IRQ0}}$	P14/TIOCA1/ $\overline{\text{IRQ0}}$		VSS
7	D2	P15/TIOCB1/TCLKC	P15/TIOCB1/TCLKC	P15/TIOCB1/TCLKC		$\overline{\text{WE}}$
8	D1	P16/TIOCA2/ $\overline{\text{IRQ1}}$	P16/TIOCA2/ $\overline{\text{IRQ1}}$	P16/TIOCA2/ $\overline{\text{IRQ1}}$		VSS
9	E4	P17/TIOCB2/TCLKD	P17/TIOCB2/TCLKD	P17/TIOCB2/TCLKD		$\overline{\text{CE}}$
10	E3	A0	PC0/A0	PC0		NC
11	E1	A1	PC1/A1	PC1		NC
12	E2	A2	PC2/A2	PC2		NC
13	F3	A3	PC3/A3	PC3		NC
14	F1	MD0	MD0	MD0		VSS
15	F2	MD1	MD1	MD1		VSS
16	F4	MD2	MD2	MD2		VSS
17	G1	A4	PC4/A4	PC4		NC
18	G2	A5	PC5/A5	PC5		NC
19	G3	A6	PC6/A6	PC6		NC
20	H1	A7	PC7/A7	PC7		NC
21	G4	USPND/TMOW	USPND/TMOW	USPND/TMOW		NC
22	H2	P30/TxD0	P30/TxD0	P30/TxD0		A10
23	J1	P31/RxD0	P31/RxD0	P31/RxD0		A11
24	H3	P32/SCK0/ $\overline{\text{IRQ4}}$	P32/SCK0/ $\overline{\text{IRQ4}}$	P32/SCK0/ $\overline{\text{IRQ4}}$		A12
25	J2	PG1/ $\overline{\text{CS3}}$ / $\overline{\text{IRQ7}}$	PG1/ $\overline{\text{CS3}}$ / $\overline{\text{IRQ7}}$	PG1/ $\overline{\text{IRQ7}}$		A15

Pin No.		Pin Name*			Programmer Mode
TFP-100G, BP-112, TFP-100GV	BP-112V	Modes 4, 5	Mode 6	Mode 7	
26	K2	PG2/CS $\bar{2}$	PG2/CS $\bar{2}$	PG2	NC
27	L2	PG3/CS $\bar{1}$	PG3/CS $\bar{1}$	PG3	NC
28	H4	PG4/CS $\bar{0}$	PG4/CS $\bar{0}$	PG4	NC
29	K3	VBUS	VBUS	VBUS	VSS
30	L3	P36 (PUDP+)	P36 (PUDP+)	P36 (PUDP+)	A16
31	J4	DrVCC	DrVCC	DrVCC	VCC
32	K4	USD+	USD+	USD+	NC
33	L4	USD-	USD-	USD-	NC
34	H5	DrVSS	DrVSS	DrVSS	VSS
35	J5	P97/AN15	P97/AN15	P97/AN15	A7
36	L5	P96/AN14	P96/AN14	P96/AN14	A6
37	K5	PB0/A8	PB0/A8	PB0	NC
38	J6	PB1/A9	PB1/A9	PB1	NC
39	L6	PB2/A10	PB2/A10	PB2	NC
40	K6	PB3/A11	PB3/A11	PB3	NC
41	H6	Vref	Vref	Vref	VCC
42	K7	P43/AN3	P43/AN3	P43/AN3	A14
43	J7	P42/AN2	P42/AN2	P42/AN2	A13
44	L8	P41/AN1	P41/AN1	P41/AN1	A9
45	H7	P40/AN0	P40/AN0	P40/AN0	A8
46	K8	PLLVSS	PLLVSS	PLLVSS	VSS
47	L9	UBPM	UBPM	UBPM	A17
48	J8	PLLVCC	PLLVCC	PLLVCC	VCC
49	K9	PB4/A12	PB4/A12	PB4	NC
50	L10	PB5/A13	PB5/A13	PB5	NC
51	K10	PB6/A14	PB6/A14	PB6	NC
52	K11	PB7/A15	PB7/A15	PB7	NC
53	J10	OSC2	OSC2	OSC2	NC
54	J11	OSC1	OSC1	OSC1	VCC
55	H9	P74/MRES	P74/MRES	P74/MRES	NC



Pin No.		Pin Name*			
TFP-100G, BP-112,	TFP-100GV BP-112V	Modes 4, 5	Mode 6	Mode 7	Programmer Mode
56	H10	P71/CS5	P71/CS5	P71	NC
57	H11	STBY	STBY	STBY	VCC
58	G8	RES	RES	RES	RES
59	G9	VSS	VSS	VSS	VSS
60	G11	XTAL	XTAL	XTAL	XTAL
61	G10	EXTAL	EXTAL	EXTAL	EXTAL
62	F9	VCC	VCC	VCC	VCC
63	F11	P70/CS4	P70/CS4	P70	NC
64	F10	PE0/D0	PE0/D0	PE0	D0
65	F8	PE1/D1	PE1/D1	PE1	D1
66	E11	PE2/D2	PE2/D2	PE2	D2
67	E10	PE3/D3	PE3/D3	PE3	D3
68	E9	PE4/D4	PE4/D4	PE4	D4
69	D11	PE5/D5	PE5/D5	PE5	D5
70	E8	PE6/D6	PE6/D6	PE6	D6
71	D10	PE7/D7	PE7/D7	PE7	D7
72	C11	D8	D8	PD0	NC
73	D9	D9	D9	PD1	NC
74	C10	D10	D10	PD2	NC
75	B11	D11	D11	PD3	NC
76	B10	D12	D12	PD4	NC
77	A10	D13	D13	PD5	NC
78	D8	D14	D14	PD6	NC
79	B9	D15	D15	PD7	NC
80	A9	FWE	FWE	FWE	FWE
81	C8	NMI	NMI	NMI	VCC
82	B8	EMLE/NC	EMLE/NC	EMLE/NC	VSS
83	A8	TDO/NC	TDO/NC	TDO/NC	NC
84	D7	TCK/NC	TCK/NC	TCK/NC	VCC
85	C7	TMS/NC	TMS/NC	TMS/NC	VCC

Pin No.		Pin Name*			
TFP-100G, BP-112, TFP-100GV BP-112V		Modes 4, 5	Mode 6	Mode 7	Programmer Mode
86	A7	$\overline{\text{TRST}}/\text{NC}$	$\overline{\text{TRST}}/\text{NC}$	$\overline{\text{TRST}}/\text{NC}$	RES
87	B7	TDI/NC	TDI/NC	TDI/NC	VSS
88	C6	VCC	VCC	VCC	VCC
89	A6	PF7/ $\phi$	PF7/ $\phi$	PF7/ $\phi$	NC
90	B6	VSS	VSS	VSS	VSS
91	D6	$\overline{\text{AS}}$	$\overline{\text{AS}}$	PF6	NC
92	A5	$\overline{\text{RD}}$	$\overline{\text{RD}}$	PF5	NC
93	B5	$\overline{\text{HWR}}$	$\overline{\text{HWR}}$	PF4	NC
94	C5	PF3/LWR/ADTRG/IRQ3	PF3/LWR/ADTRG/IRQ3	PF3/ADTRG/IRQ3	VCC
95	A4	PF2/WAIT	PF2/WAIT	PF2	NC
96	D5	PF1/BACK	PF1/BACK	PF1	NC
97	B4	PF0/BREQ/IRQ2	PF0/BREQ/IRQ2	PF0/IRQ2	VCC
98	A3	PA3/A19/SCK2	PA3/A19/SCK2	PA3/SCK2	A1
99	C4	PA2/A18/RxD2	PA2/A18/RxD2	PA2/RxD2	A0
100	B3	PA1/A17/TxD2	PA1/A17/TxD2	PA1/TxD2	$\overline{\text{OE}}$

Note: \* The NC should be left open.

**Table 1.2 Pin Functions in Each Operating Mode for H8S/2212 Group**

Pin No.		Pin Name*
FP-64E, FP-64EV, TNP-64B, TNP-64BV		Mode 7 Programmer Mode
1	P10/TIOCA0	A2
2	P11/TIOCB0	A3
3	P12/TIOCC0/TCLKA	A4
4	P13/TIOCD0/TCLKB	A5
5	P14/TIOCA1/ $\overline{\text{IRQ0}}$	VSS
6	P15/TIOCB1/TCLKC	$\overline{\text{WE}}$
7	P16/TIOCA2/ $\overline{\text{IRQ1}}$	VSS
8	P17/TIOCB2/TCLKD	$\overline{\text{CE}}$
9	MD0	VSS

Pin No.	Pin Name*	
<b>FP-64E, FP-64EV, TNP-64B, TNP-64BV</b>	<b>Mode 7</b>	<b>Programmer Mode</b>
10	MD1	VSS
11	MD2	VSS
12	USPND/TMOW	NC
13	P30/TxD0	A10
14	P31/RxD0	A11
15	P32/SCK0/IRQ4	A12
16	PG1/IRQ7	A15
17	VBUS	VSS
18	P36(PD+)	A16
19	DrVCC	VCC
20	USD+	NC
21	USD-	NC
22	DrVSS	VSS
23	P97/AN15	A7
24	P96/AN14	A6
25	Vref	VCC
26	P43/AN3	A14
27	P42/AN2	A13
28	P41/AN1	A9
29	P40/AN0	A8
30	PLL VSS	VSS
31	UBPM	A17
32	PLL VCC	VCC
33	OSC2	NC
34	OSC1	VCC
35	STBY	VCC
36	RES	RES
37	VSS	VSS
38	XTAL	XTAL

Pin No.		Pin Name*
<b>FP-64E, FP-64EV, TNP-64B, TNP-64BV</b>	<b>Mode 7</b>	<b>Programmer Mode</b>
39	EXTAL	EXTAL
40	VCC	VCC
41	PE0	D0
42	PE1	D1
43	PE2	D2
44	PE3	D3
45	PE4	D4
46	PE5	D5
47	PE6	D6
48	PE7	D7
49	FWE	FWE
50	NMI	VCC
51	EMLE/NC	VSS
52	TDO/P77	NC
53	TCK/P76	VCC
54	TMS/P75	VCC
55	$\overline{\text{TRST}}/\text{NC}$	$\overline{\text{RES}}$
56	TDI/PG0	VSS
57	VCC	VCC
58	PF7/ $\phi$	NC
59	VSS	VSS
60	$\overline{\text{PF3/ADTRG/IRQ3}}$	VCC
61	$\overline{\text{PF0/IRQ2}}$	VCC
62	PA3/SCK2	A1
63	PA2/RxD2	A0
64	PA1/TxD2	$\overline{\text{OE}}$

Note: \* The NC should be left open.

## 1.5 Pin Functions

Type	Symbol	Pin No.			I/O	Function
		TFP-100G, TFP-100GV	BP-112, BP-112V	FP-64E, FP-64EV, TNP-64B, TNP-64BV		
Power supply	VCC	62	F9	40	Input	Power supply pins. Connect all these pins to the system power supply.
		88	C6	57		
	VSS	59	G9	37	Input	Ground pins. Connect all these pins to the system power supply (0 V).
		90	B6	59		
PLLVCC	48	J8	32	Input	Power supply pin for an on-chip PLL oscillator. Connect this pin to the system power supply.	
PLLVSS	46	K8	30	Input	Ground pin for an on-chip PLL oscillator	
Clock	XTAL	60	G11	38	Input	For connection to a crystal resonator. For examples of crystal resonator connection and external clock input, see section 19, Clock Pulse Generator.
	EXTAL	61	G10	39	Input	For connection to a crystal resonator. An external clock can be supplied from the EXTAL pin. For examples of crystal resonator connection and external clock input, see section 19, Clock Pulse Generator.
	OSC1	54	J11	34	Input	For connection to a 32.768-kHz crystal resonator. For examples of crystal resonator connection, see section 19, Clock Pulse Generator.
	OSC2	53	J10	33		
	$\phi$	89	A6	58	Output	Supplies the system clock to external devices.
Operating mode control	MD2	16	F4	11	Input	Set the operating mode. Inputs at these pins cannot be modified during operation.  Sets the operating mode. Inputs at these pins should not be changed during operation. Except for mode changing, be sure to fix the levels of the mode pins (MD2 to MD0) by pulling them down or pulling them up until the power turns off.
	MD1	15	F2	10		
	MD0	14	F1	9		

Type	Symbol	Pin No.			I/O	Function
		TFP-100G, TFP-100GV	BP-112, BP-112V	FP-64E, FP-64EV, TNP-64B, TNP-64BV		
System control	$\overline{\text{RES}}^*$	58	G8	36	Input	Reset pin. When this pin is driven low, the chip is reset.
	$\overline{\text{STBY}}^*$	57	H11	35	Input	When this pin is driven low, a transition is made to hardware standby mode.
	$\overline{\text{MRES}}$	55	H9	—	Input	When this pin is driven low, a transition is made to manual reset mode. (Supported only by the H8S/2218 Group)
	$\overline{\text{BREQ}}$	97	B4	—	Input	Used by an external bus master to issue a bus request to this LSI (Supported only by the H8S/2218 Group)
	$\overline{\text{BACK}}$	96	D5	—	Output	Indicates that the bus has been released to an external bus master. (Supported only by the H8S/2218 Group)
	FWE	80	A9	49	Input	Pin for use by flash memory. This pin is only used in the flash memory version. In the masked ROM version, it should be connected to the system power supply (0 V).
	EMLE	82	B8	51	Input	Emulator enable When E10A is not used, connect this pin to the system power supply (0 V). When E10A is used, this pin should be fixed high.
Interrupts	$\text{NMI}^*$	81	C8	50	Input	Nonmaskable interrupt pin. If this pin is not used, it should be fixed high.
	$\overline{\text{IRQ7}}$	25	J2	16	Input	These pins request a maskable interrupt.
	$\overline{\text{IRQ4}}$	24	H3	15		
	$\overline{\text{IRQ3}}$	94	C5	60		
	$\overline{\text{IRQ2}}$	97	B4	61		
	$\overline{\text{IRQ1}}$	8	D1	7		
	$\overline{\text{IRQ0}}$	6	D3	5		

Type	Symbol	Pin No.			I/O	Function
		TFP-100G, TFP-100GV	BP-112, BP-112V	FP-64E, FP-64EV, TNP-64B, TNP-64BV		
Address bus	A23	5	C1	—	Output	These pins output an address. (Supported only by the H8S/2218 Group)
	A22	4	C2	—		
	A21	3	D4	—		
	A20	2	B1	—		
	A19	98	A3	—		
	A18	99	C4	—		
	A17	100	B3	—		
	A16	1	B2	—		
	A15	52	K11	—		
	A14	51	K10	—		
	A13	50	L10	—		
	A12	49	K9	—		
	A11	40	K6	—		
	A10	39	L6	—		
	A9	38	J6	—		
	A8	37	K5	—		
	A7	20	H1	—		
	A6	19	G3	—		
	A5	18	G2	—		
	A4	17	G1	—		
A3	13	F3	—			
A2	12	E2	—			
A1	11	E1	—			
A0	10	E3	—			

Type	Symbol	Pin No.			I/O	Function
		TFP-100G, TFP-100GV	BP-112, BP-112V	FP-64E, FP-64EV, TNP-64B, TNP-64BV		
Data bus	D15	79	B9	—	I/O	These pins constitute a bi-directional data bus. (Supported only by the H8S/2218 Group)
	D14	78	D8	—		
	D13	77	A10	—		
	D12	76	B10	—		
	D11	75	B11	—		
	D10	74	C10	—		
	D9	73	D9	—		
	D8	72	C11	—		
	D7	71	D10	—		
	D6	70	E8	—		
	D5	69	D11	—		
	D4	68	E9	—		
	D3	67	E10	—		
	D2	66	E11	—		
	D1	65	F8	—		
D0	64	F10	—			
Bus control	$\overline{CS5}$	56	H10	—	Output	Signals for selecting areas 5 to 0 in the external address space. (Supported only by the H8S/2218 Group)
	$\overline{CS4}$	63	F11	—		
	$\overline{CS3}$	25	J2	—		
	$\overline{CS2}$	26	K2	—		
	$\overline{CS1}$	27	L2	—		
	$\overline{CS0}$	28	H4	—		
	$\overline{AS}$	91	D6	—		
$\overline{RD}$	92	A5	—	Output	When this pin is low, it indicates that the external address space can be read. (Supported only by the H8S/2218 Group)	



Type	Symbol	Pin No.			I/O	Function
		TFP-100G, TFP-100GV	BP-112, BP-112V	FP-64E, FP-64EV, TNP-64B, TNP-64BV		
Bus control	$\overline{\text{HWR}}$	93	B5	—	Output	A strobe signal that writes to external address space and indicates that the upper half (D15 to D8) of the data bus is enabled. (Supported only by the H8S/2218 Group)
	$\overline{\text{LWR}}$	94	C5	—	Output	A strobe signal that writes to external address space and indicates that the lower half (D7 to D0) of the data bus is enabled. (Supported only by the H8S/2218 Group)
	$\overline{\text{WAIT}}$	95	A4	—	Input	Requests insertion of a wait state in the bus cycle when accessing external 3-state address space. (Supported only by the H8S/2218 Group)
16-bit timer pulse unit (TPU)	TCLKA	4	C2	3	Input	TPU external clock input pins
	TCLKB	5	C1	4		
	TCLKC	7	D2	6		
	TCLKD	9	E4	8		
	TIOCA0	2	B1	1	I/O	The TGRA_0 to TGRD_0 input capture input/output compare output/PWM output pins
	TIOCB0	3	D4	2		
	TIOCC0	4	C2	3		
	TIOCD0	5	C1	4		
TIOCA1	6	D3	5	I/O	The TGRA_1 and TGRB_1 input capture input/output compare output/PWM output pins	
TIOCB1	7	D2	6			
TIOCA2	8	D1	7	I/O	The TGRA_2 and TGRB_2 input capture input/output compare output/PWM output pins	
TIOCB2	9	E4	8			
Realtime clock (RTC)	TMOW	21	G4	12	Output	The divided clock output pin

Type	Symbol	Pin No.			I/O	Function
		TFP-100G, TFP-100GV	BP-112, BP-112V	FP-64E, FP-64EV, TNP-64B, TNP-64BV		
Serial communication interface (SCI)	TxD2	100	B3	64	Output	Data output pins
	TxD0	22	H2	13		
	RxD2	99	C4	63	Input	Data input pins
	RxD0	23	J1	14		
	SCK2	98	A3	62	I/O	Clock input/output pins
	SCK0	24	H3	15		
A/D converter	AN15	35	J5	23	Input	Analog input pins for the A/D converter
	AN14	36	L5	24		
	AN3	42	K7	26		
	AN2	43	J7	27		
	AN1	44	L8	28		
	AN0	45	H7	29		
	ADTRG	94	C5	60	Input	Pin for input of an external trigger to start A/D conversion
	Vref	41	H6	25	Input	The reference voltage input pin for the A/D converter. When the A/D converter is not used, this pin should be connected to the system power supply (VCC).
Boundary scan (Supported only by the HD64F2218, HD64F2218U, HD64F2218CU and HD64F2217CU)	TMS	85	C7	54	Input	Control signal input pin for the boundary scan
	TCK	84	D7	53	Input	Clock input pin for the boundary scan
	TDO	83	A8	52	Output	Data output pin for the boundary scan
	TDI	87	B7	56	Input	Data input pin for the boundary scan
	TRST	86	A7	55	Input	Reset pin for the TAP controller
USB	DrVCC	31	J4	19	Input	Power supply pin for the on-chip transceiver. Connect this pin to the system power supply.
	DrVSS	34	H5	22	Input	Ground pin for the on-chip transceiver.

Type	Symbol	Pin No.			I/O	Function
		TFP-100G, TFP-100GV	BP-112, BP-112V	FP-64E, FP-64EV, TNP-64B, TNP-64BV		
USB	USD+*	32	K4	20	I/O	USB data I/O pin
	USD-*	33	L4	21		
	VBUS*	29	K3	17	Input	Connection/disconnection detecting input pin for the USB cable
	USPND	21	G4	12	Output	USB suspend output This pin is driven high when a transition is made to suspend state.
	$\overline{\text{UBPM}}$	47	L9	31	Input	Bus power/self power mode setting Input When the USB is used in bus power mode, this input pin must be fixed low. When the USB is used in self power mode, this input pin must be fixed high.
	P36 (PUPD+)	30	L3	18	I/O	Use as D+ signal pull-up control pin.
I/O port	P17	9	E4	8	I/O	8-bit I/O pins
	P16	8	D1	7		
	P15	7	D2	6		
	P14	6	D3	5		
	P13	5	C1	4		
	P12	4	C2	3		
	P11	3	D4	2		
	P10	2	B1	1		
	P36	30	L3	18	I/O	4-bit I/O pins (Use P36 as D+ signal pull-up control pin of USB.)
	P32	24	H3	15		
	P31	23	J1	14		
	P30	22	H2	13		
	P43	42	K7	26	Input	4-bit input pins
	P42	43	J7	27		
	P41	44	L8	28		
P40	45	H7	29			

Type	Symbol	Pin No.			I/O	Function
		TFP-100G, TFP-100GV	BP-112, BP-112V	FP-64E, FP-64EV, TNP-64B, TNP-64BV		
I/O port	P77	—	—	52	I/O	3-bit I/O pins
	P76	—	—	53		
	P75	—	—	54		
	P74	55	H9	—		
	P71	56	H10	—		
	P70	63	F11	—		
	P97	35	J5	23		
P96	36	L5	24			
PA3	98	A3	62	I/O	4-bit I/O pins for the H8S/2218 Group. 3-bit I/O pins for the H8S/2212 Group.	
PA2	99	C4	63			
PA1	100	B3	64			
PA0	1	B2	—			
PB7	52	K11	—	I/O	8-bit I/O pins (Supported only by the H8S/2218 Group)	
PB6	51	K10	—			
PB5	50	L10	—			
PB4	49	K9	—			
PB3	40	K6	—			
PB2	39	L6	—			
PB1	38	J6	—			
PB0	37	K5	—			
PC7	20	H1	—	I/O	8-bit I/O pins (Supported only by the H8S/2218 Group)	
PC6	19	G3	—			
PC5	18	G2	—			
PC4	17	G1	—			
PC3	13	F3	—			
PC2	12	E2	—			
PC1	11	E1	—			
PC0	10	E3	—			

Type	Symbol	Pin No.			I/O	Function
		TFP-100G, TFP-100GV	BP-112, BP-112V	FP-64E, FP-64EV, TNP-64B, TNP-64BV		
I/O port	PD7	79	B9	—	I/O	8-bit I/O pins (Supported only by the H8S/2218 Group)
	PD6	78	D8	—		
	PD5	77	A10	—		
	PD4	76	B10	—		
	PD3	75	B11	—		
	PD2	74	C10	—		
	PD1	73	D9	—		
	PD0	72	C11	—		
PE7	71	D10	48	I/O	8-bit I/O pins	
PE6	70	E8	47			
PE5	69	D11	46			
PE4	68	E9	45			
PE3	67	E10	44			
PE2	66	E11	43			
PE1	65	F8	42			
PE0	64	F10	41			
PF7	89	A6	58	I/O	8-bit I/O pins for the H8S/2218 Group. 3-bit I/O pins for the H8S/2212 Group.	
PF6	91	D6	—			
PF5	92	A5	—			
PF4	93	B5	—			
PF3	94	C5	60			
PF2	95	A4	—			
PF1	96	D5	—			
PF0	97	B4	61			
PG4	28	H4	—	I/O	4-bit I/O pins for the H8S/2218 Group. 2-bit I/O pins for the H8S/2212 Group.	
PG3	27	L2	—			
PG2	26	K2	—			
PG1	25	J2	16			
PG0	—	—	56			

Note: \* Anti-noise measures should be taken to prevent malfunction.



## Section 2 CPU

The H8S/2000 CPU is a high-speed central processing unit with an internal 32-bit architecture that is upward compatible with the H8/300 and H8/300H CPUs. The H8S/2000 CPU has sixteen 16-bit general registers, can address a 16-Mbyte linear address space, and is ideal for realtime control.

This section describes the H8S/2000 CPU. The usable modes and address spaces differ depending on the product. For details on each product, refer to section 3, MCU Operating Modes.

### 2.1 Features

- Upward-compatible with H8/300 and H8/300H CPUs
  - Can execute H8/300 and H8/300H CPU object programs
- General-register architecture
  - Sixteen 16-bit general registers also usable as sixteen 8-bit registers or eight 32-bit registers
- Sixty-five basic instructions
  - 8/16/32-bit arithmetic and logic instructions
  - Multiply and divide instructions
  - Powerful bit-manipulation instructions
- Eight addressing modes
  - Register direct [Rn]
  - Register indirect [ $@ERn$ ]
  - Register indirect with displacement [ $@(d:16,ERn)$  or  $@(d:32,ERn)$ ]
  - Register indirect with post-increment or pre-decrement [ $@ERn+$  or  $@-ERn$ ]
  - Absolute address [ $@aa:8$ ,  $@aa:16$ ,  $@aa:24$ , or  $@aa:32$ ]
  - Immediate [ $\#xx:8$ ,  $\#xx:16$ , or  $\#xx:32$ ]
  - Program-counter relative [ $@(d:8,PC)$  or  $@(d:16,PC)$ ]
  - Memory indirect [ $@@aa:8$ ]
- 16-Mbyte address space
  - Program: 16 Mbytes
  - Data: 16 Mbytes
- High-speed operation
  - All frequently-used instructions execute in one or two states
  - 8/16/32-bit register-register add/subtract: 1 state
  - $8 \times 8$ -bit register-register multiply: 12 states
  - $16 \div 8$ -bit register-register divide: 12 states

- $16 \times 16$ -bit register-register multiply: 20 states
- $32 \div 16$ -bit register-register divide: 20 states
- Two CPU operating modes
  - Normal mode\*
  - Advanced mode

Note: \* Normal mode is not available in this LSI.

- Power-down state
  - Transition to power-down state by SLEEP instruction
  - CPU clock speed selection

### 2.1.1 Differences between H8S/2600 CPU and H8S/2000 CPU

The differences between the H8S/2600 CPU and the H8S/2000 CPU are as shown below.

- Register configuration
  - The MAC register is supported only by the H8S/2600 CPU.
- Basic instructions
  - The four instructions MAC, CLRMAC, LDMAC, and STMAC are supported only by the H8S/2600 CPU.
- The number of execution states of the MULXU and MULXS instructions

Instruction	Mnemonic	Execution States	
		H8S/2600	H8S/2000
MULXU	MULXU.B Rs, Rd	3	12
	MULXU.W Rs, ERd	4	20
MULXS	MULXS.B Rs, Rd	4	13
	MULXS.W Rs, ERd	5	21

In addition, there are differences in address space, CCR and EXR register functions, power-down modes, etc., depending on the model.



### 2.1.2 Differences from H8/300 CPU

In comparison to the H8/300 CPU, the H8S/2000 CPU has the following enhancements.

- More general registers and control registers
  - Eight 16-bit extended registers, and one 8-bit and two 32-bit control registers, have been added.
- Extended address space
  - Normal mode supports the same 64-kbyte address space as the H8/300 CPU.
  - Advanced mode supports a maximum 16-Mbyte address space.
- Enhanced addressing
  - The addressing modes have been enhanced to make effective use of the 16-Mbyte address space.
- Enhanced instructions
  - Addressing modes of bit-manipulation instructions have been enhanced.
  - Signed multiply and divide instructions have been added.
  - Two-bit shift instructions have been added.
  - Instructions for saving and restoring multiple registers have been added.
  - A test and set instruction has been added.
- Higher speed
  - Basic instructions execute twice as fast.

### 2.1.3 Differences from H8/300H CPU

In comparison to the H8/300H CPU, the H8S/2000 CPU has the following enhancements.

- Additional control register
  - One 8-bit control registers have been added.
- Enhanced instructions
  - Addressing modes of bit-manipulation instructions have been enhanced.
  - Two-bit shift instructions have been added.
  - Instructions for saving and restoring multiple registers have been added.
  - A test and set instruction has been added.
- Higher speed
  - Basic instructions execute twice as fast.

## 2.2 CPU Operating Modes

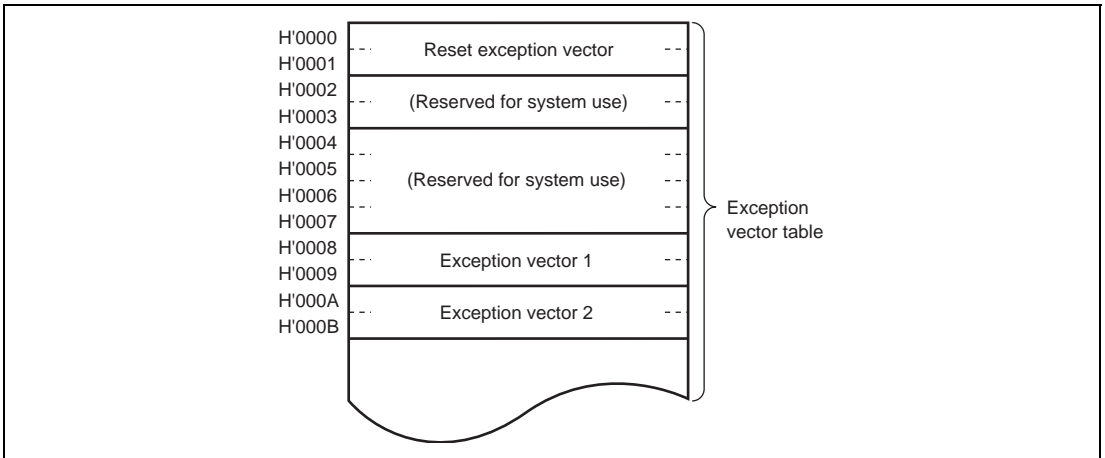
The H8S/2000 CPU has two operating modes: normal and advanced. Normal mode supports a maximum 64-kbyte address space. Advanced mode supports a maximum 16-Mbyte total address space. The mode is selected by the mode pins.

### 2.2.1 Normal Mode

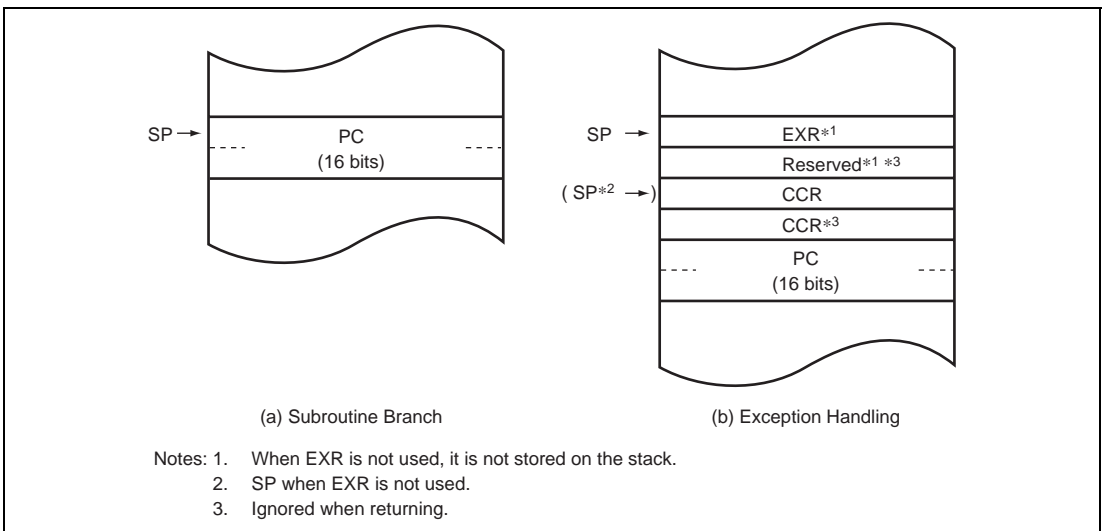
The exception vector table and stack have the same structure as in the H8/300 CPU.

- **Address Space**  
A maximum address space of 64 kbytes can be accessed.
- **Extended Registers (En)**  
The extended registers (E0 to E7) can be used as 16-bit registers, or as the upper 16-bit segments of 32-bit registers. When En is used as a 16-bit register it can contain any value, even when the corresponding general register (Rn) is used as an address register. If the general register is referenced in the register indirect addressing mode with pre-decrement (@-Rn) or post-increment (@Rn+) and a carry or borrow occurs, however, the value in the corresponding extended register (En) will be affected.
- **Instruction Set**  
All instructions and addressing modes can be used. Only the lower 16 bits of effective addresses (EA) are valid.
- **Exception Vector Table and Memory Indirect Branch Addresses**  
In normal mode the top area starting at H'0000 is allocated to the exception vector table. One branch address is stored per 16 bits. The exception vector table in normal mode is shown in figure 2.1. For details of the exception vector table, see section 4, Exception Handling.  
The memory indirect addressing mode (@@aa:8) employed in the JMP and JSR instructions uses an 8-bit absolute address included in the instruction code to specify a memory operand that contains a branch address. In normal mode the operand is a 16-bit (word) operand, providing a 16-bit branch address. Branch addresses can be stored in the top area from H'0000 to H'00FF. Note that this area is also used for the exception vector table.
- **Stack Structure**  
When the program counter (PC) is pushed onto the stack in a subroutine call, and the PC, condition-code register (CCR), and extended control register (EXR) are pushed onto the stack in exception handling, they are stored as shown in figure 2.2. EXR is not pushed onto the stack in interrupt control mode 0. For details, see section 4, Exception Handling.

Note: Normal mode is not available in this LSI.



**Figure 2.1 Exception Vector Table (Normal Mode)**



**Figure 2.2 Stack Structure in Normal Mode**

## 2.2.2 Advanced Mode

- Address Space

Linear access is provided to a 16-Mbyte maximum address space.

- Extended Registers (En)

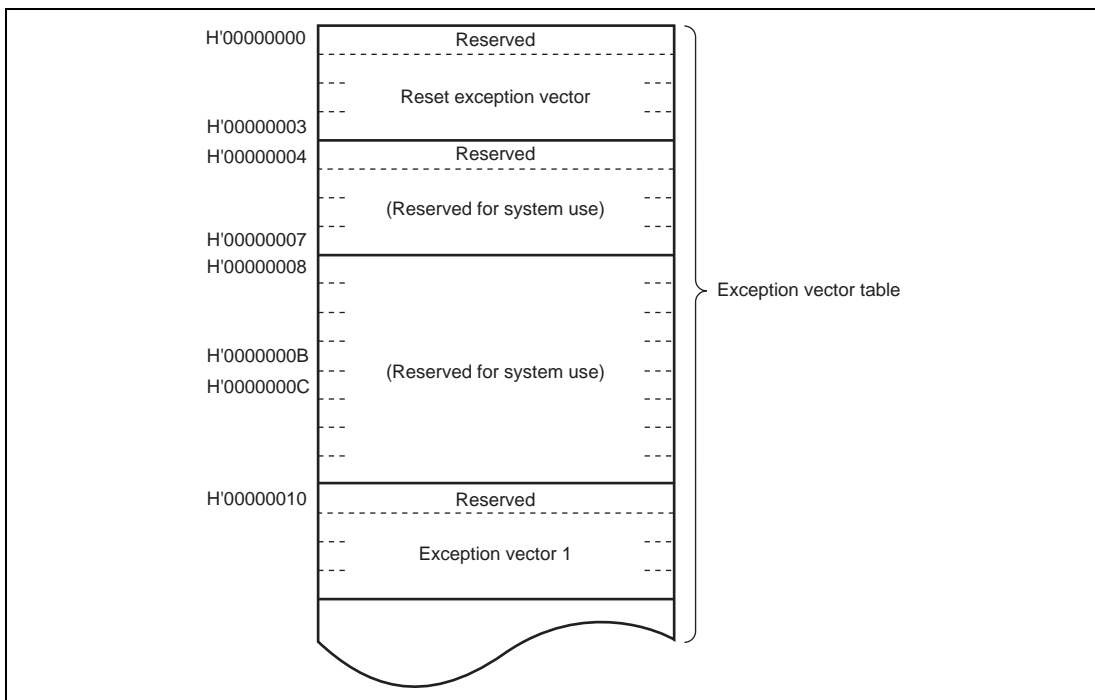
The extended registers (E0 to E7) can be used as 16-bit registers, or as the upper 16-bit segments of 32-bit registers or address registers.

- Instruction Set

All instructions and addressing modes can be used.

- Exception Vector Table and Memory Indirect Branch Addresses

In advanced mode the top area starting at H'00000000 is allocated to the exception vector table in units of 32 bits. In each 32 bits, the upper 8 bits are ignored and a branch address is stored in the lower 24 bits (figure 2.3). For details of the exception vector table, see section 4, Exception Handling.

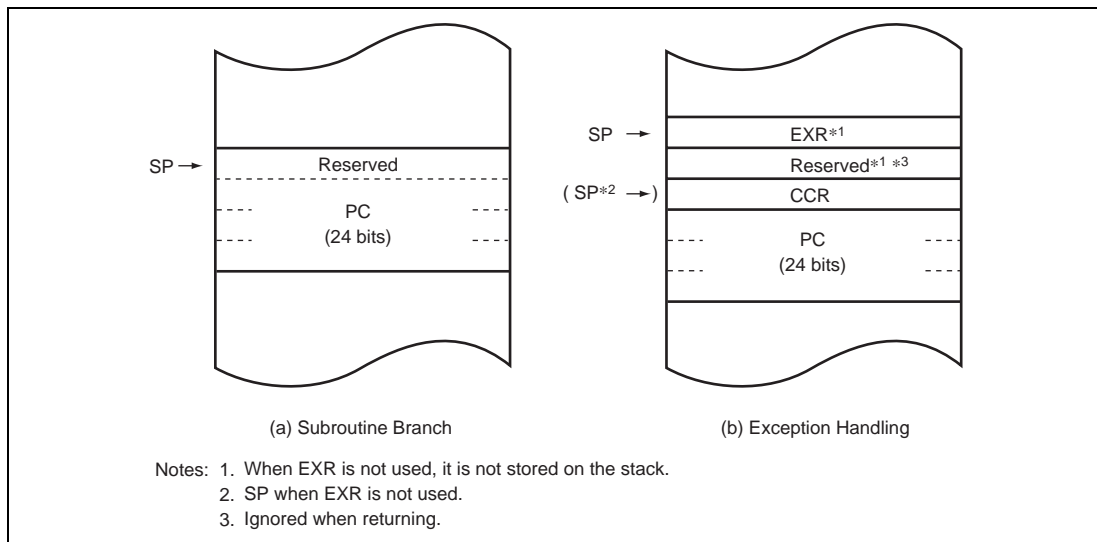


**Figure 2.3 Exception Vector Table (Advanced Mode)**

The memory indirect addressing mode (@@aa:8) employed in the JMP and JSR instructions uses an 8-bit absolute address included in the instruction code to specify a memory operand that contains a branch address. In advanced mode the operand is a 32-bit longword operand, providing a 32-bit branch address. The upper 8 bits of these 32 bits are a reserved area that is regarded as H'00. Branch addresses can be stored in the area from H'00000000 to H'000000FF. Note that the first part of this range is also the exception vector table.

- Stack Structure

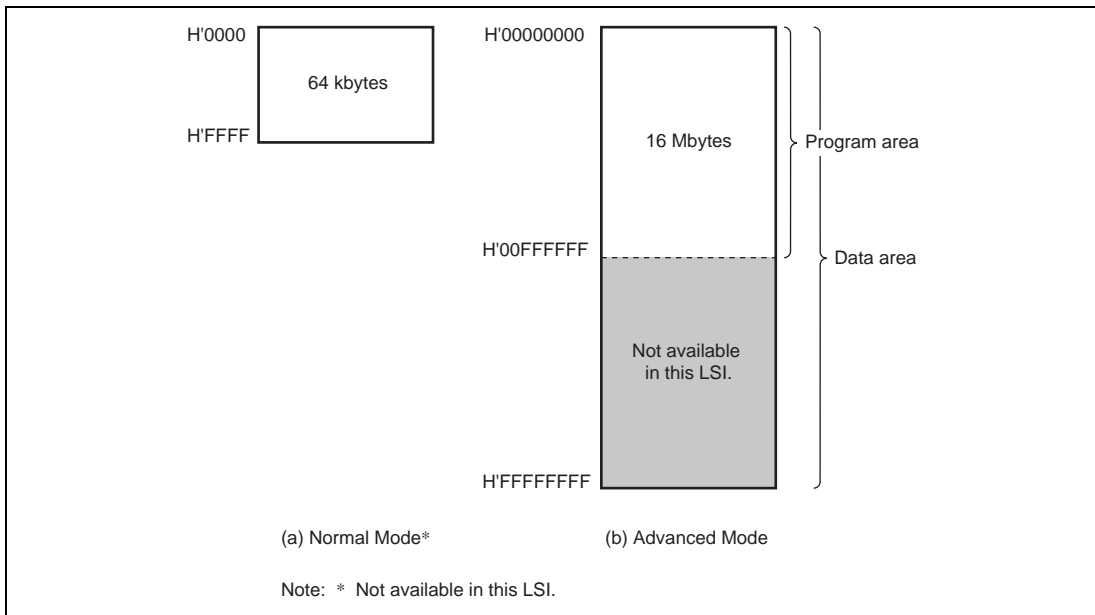
In advanced mode, when the program counter (PC) is pushed onto the stack in a subroutine call, and the PC, condition-code register (CCR), and extended control register (EXR) are pushed onto the stack in exception handling, they are stored as shown in figure 2.4. When EXR is invalid, it is not pushed onto the stack. For details, see section 4, Exception Handling.



**Figure 2.4 Stack Structure in Advanced Mode**

## 2.3 Address Space

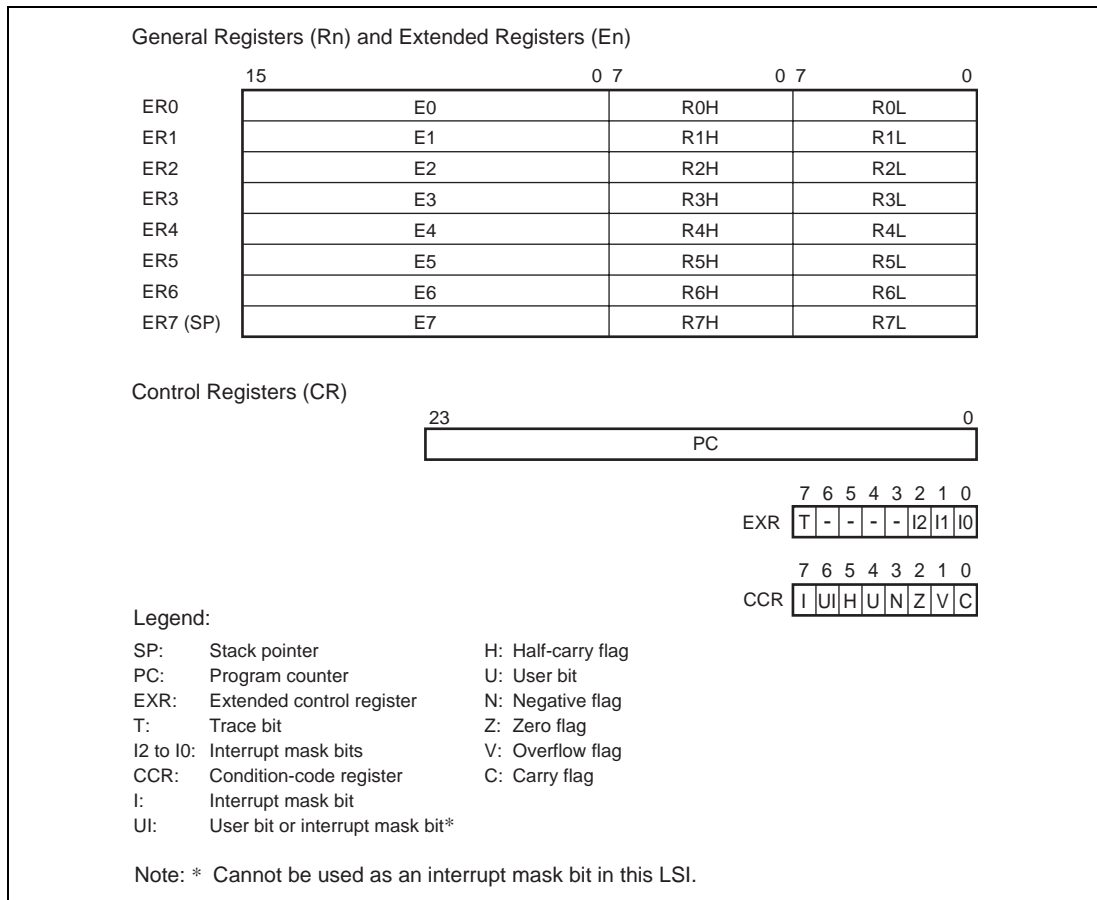
Figure 2.5 shows a memory map of the H8S/2000 CPU. The H8S/2000 CPU provides linear access to a maximum 64-kbyte address space in normal mode, and a maximum 16-Mbyte (architecturally 4-Gbyte) address space in advanced mode. The usable modes and address spaces differ depending on the product. For details on each product, refer to section 3, MCU Operating Modes.



**Figure 2.5 Memory Map**

## 2.4 Register Configuration

The H8S/2000 CPU has the internal registers shown in figure 2.6. There are two types of registers: general registers and control registers. Control registers are a 24-bit program counter (PC), an 8-bit extended control register (EXR), and an 8-bit condition code register (CCR).



**Figure 2.6 CPU Registers**

## 2.4.1 General Registers

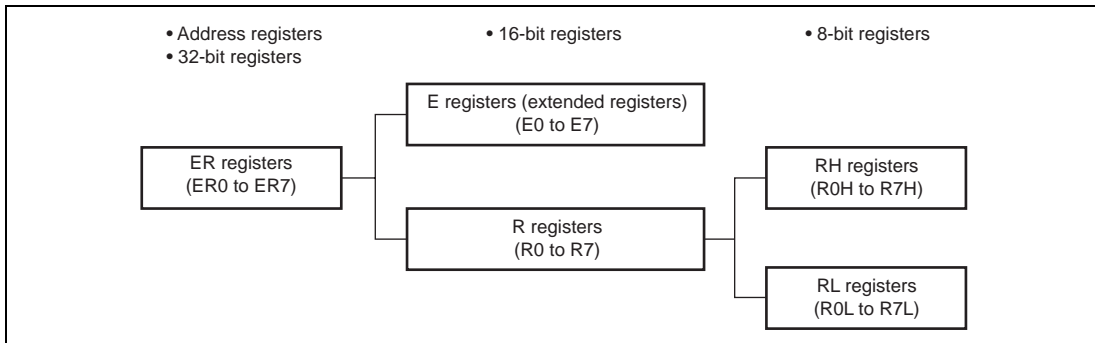
The H8S/2000 CPU has eight 32-bit general registers. These general registers are all functionally alike and can be used as both address registers and data registers. When a general register is used as a data register, it can be accessed as a 32-bit, 16-bit, or 8-bit register. Figure 2.7 illustrates the usage of the general registers. When the general registers are used as 32-bit registers or address registers, they are designated by the letters ER (ER0 to ER7).

The ER registers divide into 16-bit general registers designated by the letters E (E0 to E7) and R (R0 to R7). These registers are functionally equivalent, providing a maximum sixteen 16-bit registers. The E registers (E0 to E7) are also referred to as extended registers.

The R registers divide into 8-bit general registers designated by the letters RH (R0H to R7H) and RL (R0L to R7L). These registers are functionally equivalent, providing a maximum sixteen 8-bit registers.

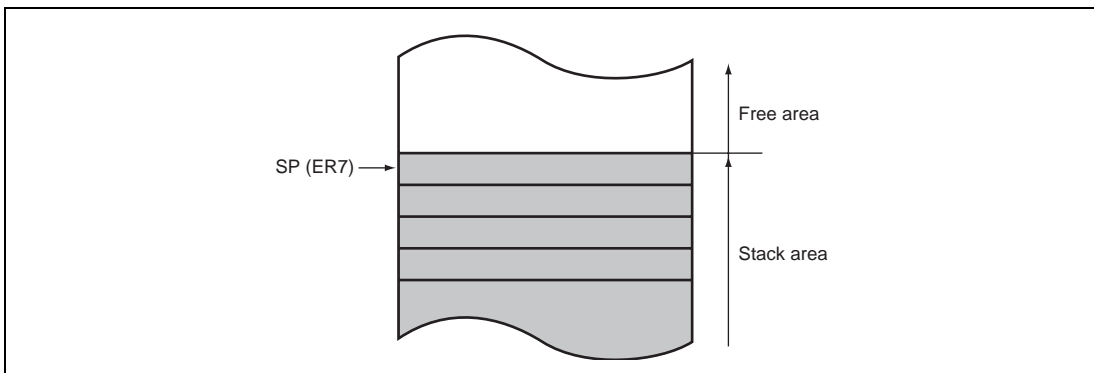
The usage of each register can be selected independently.

General register ER7 has the function of stack pointer (SP) in addition to its general-register function, and is used implicitly in exception handling and subroutine calls. Figure 2.8 shows the stack.



**Figure 2.7 Usage of General Registers**





**Figure 2.8 Stack**

### 2.4.2 Program Counter (PC)

This 24-bit counter indicates the address of the next instruction the CPU will execute. The length of all CPU instructions is two bytes (one word), so the least significant PC bit is ignored. (When an instruction is fetched, the least significant PC bit is regarded as 0.)

### 2.4.3 Extended Control Register (EXR)

EXR is an 8-bit register that manipulates the LDC, STC, ANDC, ORC, and XORC instructions. When these instructions except for the STC instruction is executed, all interrupts including NMI will be masked for three states after execution is completed.

Bit	Bit Name	Initial Value	R/W	Description
7	T	0	R/W	Trace Bit When this bit is set to 1, a trace exception is generated each time an instruction is executed. When this bit is cleared to 0, instructions are executed in sequence.
6 to 3	–	All 1	–	Reserved These bits are always read as 1.
2	I2	1	R/W	These bits designate the interrupt mask level (0 to 7). For details, refer to section 5, Interrupt Controller.
1	I1			
0	I0			

### 2.4.4 Condition-Code Register (CCR)

This 8-bit register contains internal CPU status information, including an interrupt mask bit (I) and half-carry (H), negative (N), zero (Z), overflow (V), and carry (C) flags.

Operations can be performed on the CCR bits by the LDC, STC, ANDC, ORC, and XORC instructions. The N, Z, V, and C flags are used as branching conditions for conditional branch (Bcc) instructions.

Bit	Bit Name	Initial Value	R/W	Description
7	I	1	R/W	<p>Interrupt Mask Bit</p> <p>Masks interrupts other than NMI when set to 1. NMI is accepted regardless of the I bit setting. The I bit is set to 1 by hardware at the start of an exception-handling sequence. For details, refer to section 5, Interrupt Controller.</p>
6	UI	undefined	R/W	<p>User Bit or Interrupt Mask Bit</p> <p>Can be written and read by software using the LDC, STC, ANDC, ORC, and XORC instructions. This bit cannot be used as an interrupt mask bit in this LSI.</p>
5	H	undefined	R/W	<p>Half-Carry Flag</p> <p>When the ADD.B, ADDX.B, SUB.B, SUBX.B, CMP.B or NEG.B instruction is executed, this flag is set to 1 if there is a carry or borrow at bit 3, and cleared to 0 otherwise. When the ADD.W, SUB.W, CMP.W, or NEG.W instruction is executed, the H flag is set to 1 if there is a carry or borrow at bit 11, and cleared to 0 otherwise. When the ADD.L, SUB.L, CMP.L, or NEG.L instruction is executed, the H flag is set to 1 if there is a carry or borrow at bit 27, and cleared to 0 otherwise.</p>
4	U	undefined	R/W	<p>User Bit</p> <p>Can be written and read by software using the LDC, STC, ANDC, ORC, and XORC instructions.</p>
3	N	undefined	R/W	<p>Negative Flag</p> <p>Stores the value of the most significant bit of data as a sign bit.</p>
2	Z	undefined	R/W	<p>Zero Flag</p> <p>Set to 1 to indicate zero data, and cleared to 0 to indicate non-zero data.</p>

Bit	Bit Name	Initial Value	R/W	Description
1	V	undefined	R/W	<p>Overflow Flag</p> <p>Set to 1 when an arithmetic overflow occurs, and cleared to 0 at other times.</p>
0	C	undefined	R/W	<p>Carry Flag</p> <p>Set to 1 when a carry occurs, and cleared to 0 otherwise.</p> <p>Used by:</p> <ul style="list-style-type: none"> <li>• Add instructions, to indicate a carry</li> <li>• Subtract instructions, to indicate a carry</li> <li>• Shift and rotate instructions, to indicate a carry</li> </ul> <p>The carry flag is also used as a bit accumulator by bit manipulation instructions.</p>

### 2.4.5 Initial Register Values

Reset exception handling loads the CPU's program counter (PC) from the vector table, clears the trace bit in EXR to 0, and sets the interrupt mask bits in CCR and EXR to 1. The other CCR bits and the general registers are not initialized. In particular, the stack pointer (ER7) is not initialized.

The stack pointer should therefore be initialized by an MOV.L instruction executed immediately after a reset.

## 2.5 Data Formats

The H8S/2000 CPU can process 1-bit, 4-bit (BCD), 8-bit (byte), 16-bit (word), and 32-bit (longword) data. Bit-manipulation instructions operate on 1-bit data by accessing bit  $n$  ( $n = 0, 1, 2, \dots, 7$ ) of byte operand data. The DAA and DAS decimal-adjust instructions treat byte data as two digits of 4-bit BCD data.

### 2.5.1 General Register Data Formats

Figure 2.9 shows the data formats in general registers.

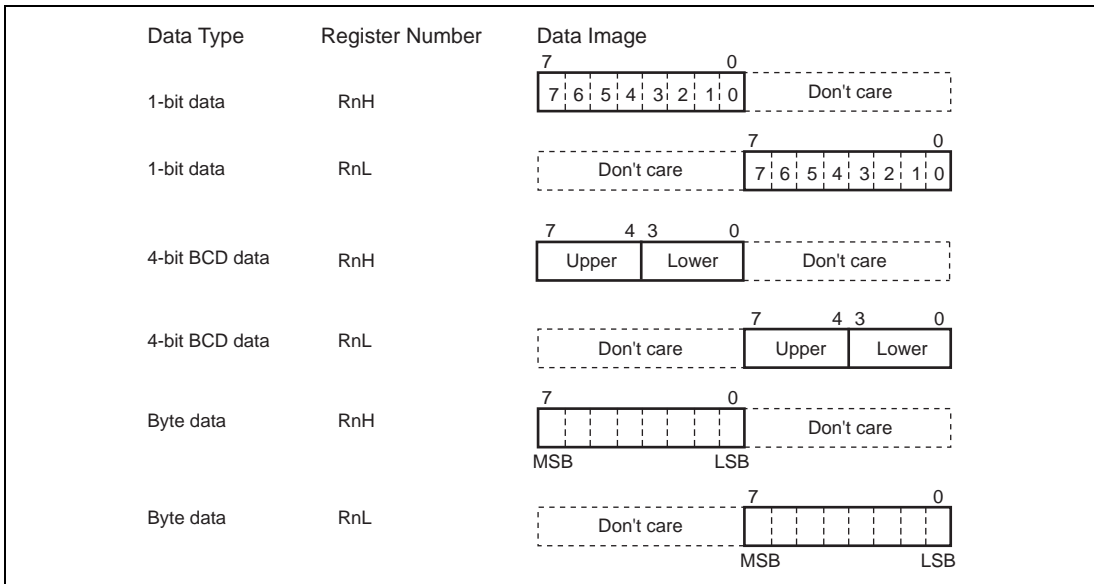


Figure 2.9 General Register Data Formats (1)

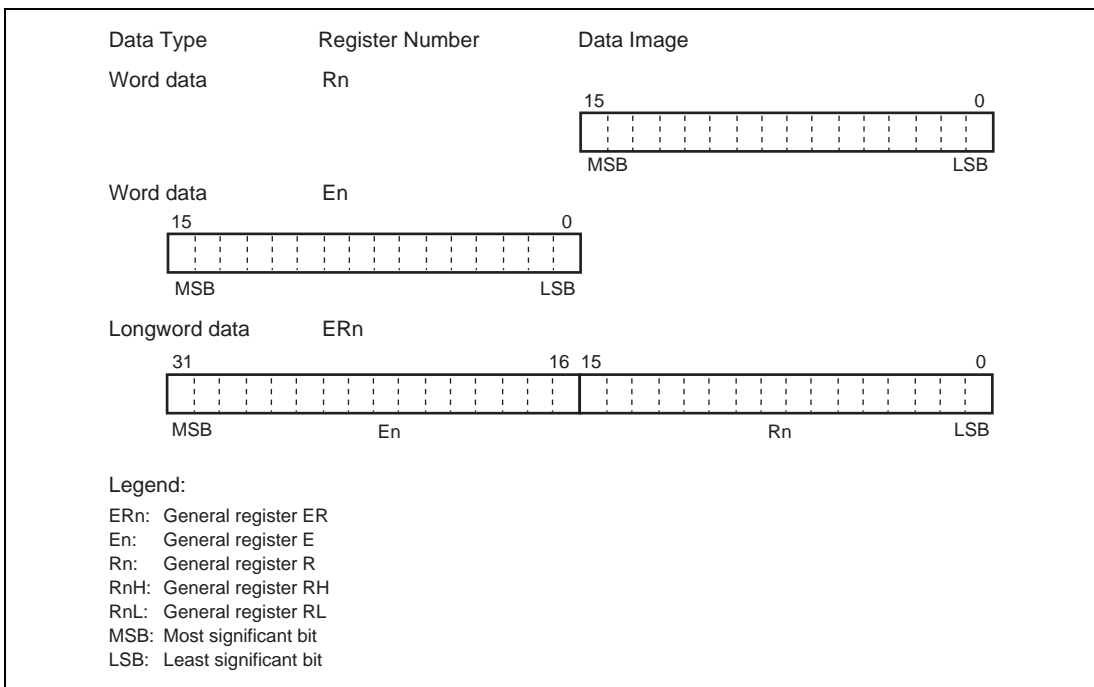


Figure 2.9 General Register Data Formats (2)



**Table 2.1 Instruction Classification**

Function	Instructions	Size	Types
Data transfer	MOV	B/W/L	5
	POP* <sup>1</sup> , PUSH* <sup>1</sup>	W/L	
	LDM* <sup>5</sup> , STM* <sup>5</sup>	L	
	MOVFPE* <sup>3</sup> , MOVTPPE* <sup>3</sup>	B	
Arithmetic operations	ADD, SUB, CMP, NEG	B/W/L	19
	ADDX, SUBX, DAA, DAS	B	
	INC, DEC	B/W/L	
	ADDS, SUBS	L	
	MULXU, DIVXU, MULXS, DIVXS	B/W	
	EXTU, EXTS	W/L	
	TAS* <sup>4</sup>	B	
Logic operations	AND, OR, XOR, NOT	B/W/L	4
Shift	SHAL, SHAR, SHLL, SHLR, ROTL, ROTR, ROTXL, ROTXR	B/W/L	8
Bit manipulation	BSET, BCLR, BNOT, BTST, BLD, BILD, BST, BIST, BAND, B BIAND, BOR, BIOR, BXOR, BIXOR	B	14
Branch	Bcc* <sup>2</sup> , JMP, BSR, JSR, RTS	–	5
System control	TRAPA, RTE, SLEEP, LDC, STC, ANDC, ORC, XORC, NOP	–	9
Block data transfer	EEPMOV	–	1
			Total: 65

Legend: B: Byte size  
W: Word size  
L: Longword size

- Notes: 1. POP.W Rn and PUSH.W Rn are identical to MOV.W @SP+, Rn and MOV.W Rn, @-SP. POP.L ERn and PUSH.L ERn are identical to MOV.L @SP+, ERn and MOV.L ERn, @-SP.
2. Bcc is the general name for conditional branch instructions.
3. Cannot be used in this LSI.
4. Only register ER0, ER1, ER4, or ER5 should be used when using the TAS instruction.
5. ER7 is used as a stack pointer in STM and LDM instructions. ER7, therefore, should not be used as a saving (STM) or restoring (LDM) register.

## 2.6.1 Table of Instructions Classified by Function

Tables 2.3 to 2.10 summarizes the instructions in each functional category. The notation used in tables 2.3 to 2.10 is defined below.

**Table 2.2 Operation Notation**

Symbol	Description
Rd	General register (destination)*
Rs	General register (source) *
Rn	General register*
ERn	General register (32-bit register)
(EAd)	Destination operand
(EAs)	Source operand
EXR	Extended control register
CCR	Condition-code register
N	N (negative) flag in CCR
Z	Z (zero) flag in CCR
V	V (overflow) flag in CCR
C	C (carry) flag in CCR
PC	Program counter
SP	Stack pointer
#IMM	Immediate data
disp	Displacement
+	Addition
-	Subtraction
×	Multiplication
÷	Division
^	Logical AND
∨	Logical OR
⊕	Logical exclusive OR
→	Move
~	NOT (logical complement)
:8/:16/:24/:32	8-, 16-, 24-, or 32-bit length

Note: \* General registers include 8-bit registers (R0H to R7H, R0L to R7L), 16-bit registers (R0 to R7, E0 to E7), and 32-bit registers (ER0 to ER7).

**Table 2.3 Data Transfer Instructions**

<b>Instruction</b>	<b>Size*<sup>1</sup></b>	<b>Function</b>
MOV	B/W/L	(EAs) → Rd, Rs → (EAd) Moves data between two general registers or between a general register and memory, or moves immediate data to a general register.
MOVFPPE	B	Cannot be used in this LSI.
MOVTPE	B	Cannot be used in this LSI.
POP	W/L	@SP+ → Rn Pops a general register from the stack. POP.W Rn is identical to MOV.W @SP+, Rn. POP.L ERn is identical to MOV.L @SP+, ERn
PUSH	W/L	Rn → @-SP Pushes a general register onto the stack. PUSH.W Rn is identical to MOV.W Rn, @-SP. PUSH.L ERn is identical to MOV.L ERn, @-SP.
LDM* <sup>2</sup>	L	@SP+ → Rn (register list) Pops two or more general registers from the stack.
STM* <sup>2</sup>	L	Rn (register list) → @-SP Pushes two or more general registers onto the stack.

Notes: 1. Size refers to the operand size.

B: Byte

W: Word

L: Longword

2. ER7 is used as a stack pointer in STM and LDM instructions. ER7, therefore, should not be used as a saving (STM) or restoring (LDM) register.



**Table 2.4 Arithmetic Operations Instructions**

<b>Instruction</b>	<b>Size*<sup>1</sup></b>	<b>Function</b>
ADD SUB	B/W/L	$Rd \pm Rs \rightarrow Rd$ , $Rd \pm \#IMM \rightarrow Rd$ Performs addition or subtraction on data in two general registers, or on immediate data and data in a general register. (Immediate byte data cannot be subtracted from byte data in a general register. Use the SUBX or ADD instruction.)
ADDX SUBX	B	$Rd \pm Rs \pm C \rightarrow Rd$ , $Rd \pm \#IMM \pm C \rightarrow Rd$ Performs addition or subtraction with carry or borrow on byte data in two general registers, or on immediate data and data in a general register.
INC DEC	B/W/L	$Rd \pm 1 \rightarrow Rd$ , $Rd \pm 2 \rightarrow Rd$ Increments or decrements a general register by 1 or 2. (Byte operands can be incremented or decremented by 1 only.)
ADDS SUBS	L	$Rd \pm 1 \rightarrow Rd$ , $Rd \pm 2 \rightarrow Rd$ , $Rd \pm 4 \rightarrow Rd$ Adds or subtracts the value 1,2, or 4 to or from data in a 32-bit register.
DAA DAS	B	$Rd$ (decimal adjust) $\rightarrow Rd$ Decimal-adjusts an addition or subtraction result in a general register by referring to the OCR to produce 4-bit BCD data.
MULXU	B/W	$Rd \times Rs \rightarrow Rd$ Performs unsigned multiplication on data in two general registers: either 8 bits $\times$ 8 bits $\rightarrow$ 16 bits or 16 bits $\times$ 16 bits $\rightarrow$ 32 bits.
MULXS	B/W	$Rd \times Rs \rightarrow Rd$ Performs signed multiplication on data in two general registers: either 8 bits $\times$ 8 bits $\rightarrow$ 16 bits or 16 bits $\times$ 16 bits $\rightarrow$ 32 bits.
DIVXU	B/W	$Rd \div Rs \rightarrow Rd$ Performs unsigned division on data in two general registers: either 16 bits $\div$ 8 bits $\rightarrow$ 8-bit quotient and 8-bit remainder or 32 bits $\div$ 16 bits $\rightarrow$ 16-bit quotient and 16-bit remainder.
DIVXS	B/W	$Rd \div Rs \rightarrow Rd$ Performs signed division on data in two general registers: either 16 bits $\div$ 8 bits $\rightarrow$ 8-bit quotient and 8-bit remainder or 32 bits $\div$ 16 bits $\rightarrow$ 16-bit quotient and 16-bit remainder.
CMP	B/W/L	$Rd - Rs$ , $Rd - \#IMM$ Compares data in a general register with data in another general register or with immediate data, and sets CCR bits according to the result.

Instruction	Size* <sup>1</sup>	Function
NEG	B/W/L	0 – Rd → Rd Takes the two's complement (arithmetic complement) of data in a general register.
EXTU	W/L	Rd (zero extension) → Rd Extends the lower 8 bits of a 16-bit register to word size, or the lower 16 bits of a 32-bit register to longword size, by padding with zeros on the left.
EXTS	W/L	Rd (sign extension) → Rd Extends the lower 8 bits of a 16-bit register to word size, or the lower 16 bits of a 32-bit register to longword size, by extending the sign bit.
TAS* <sup>2</sup>	B	@ERd – 0, 1 → (<bit 7> of @ERd) Tests memory contents, and sets the most significant bit (bit 7) to 1.

Notes: 1. Size refers to the operand size.

B: Byte

W: Word

L: Longword

2. Only register ER0, ER1, ER4, or ER5 should be used when using the TAS instruction.

**Table 2.5 Logic Operations Instructions**

Instruction	Size*	Function
AND	B/W/L	Rd $\wedge$ Rs → Rd, Rd $\wedge$ #IMM → Rd Performs a logical AND operation on a general register and another general register or immediate data.
OR	B/W/L	Rd $\vee$ Rs → Rd, Rd $\vee$ #IMM → Rd Performs a logical OR operation on a general register and another general register or immediate data.
XOR	B/W/L	Rd $\oplus$ Rs → Rd, Rd $\oplus$ #IMM → Rd Performs a logical exclusive OR operation on a general register and another general register or immediate data.
NOT	B/W/L	$\sim$ Rd → Rd Takes the one's complement (logical complement) of general register contents.

Note: \* Size refers to the operand size.

B: Byte

W: Word

L: Longword

**Table 2.6 Shift Instructions**

<b>Instruction</b>	<b>Size*</b>	<b>Function</b>
SHAL	B/W/L	Rd (shift) → Rd
SHAR		Performs an arithmetic shift on general register contents. 1-bit or 2 bit shift is possible.
SHLL	B/W/L	Rd (shift) → Rd
SHLR		Performs an logical shift on general register contents. 1-bit or 2 bit shift is possible.
ROTL	B/W/L	Rd (rotate) → Rd
ROTR		Rotates general register contents. 1-bit or 2 bit rotation is possible.
ROTXL	B/W/L	Rd (rotate) → Rd
ROTXR		Rotates general register contents through the carry flag. 1-bit or 2 bit rotation is possible.

Note: \*Size refers to the operand size.

B: Byte

W: Word

L: Longword

**Table 2.7 Bit Manipulation Instructions**

<b>Instruction</b>	<b>Size*</b>	<b>Function</b>
BSET	B	$1 \rightarrow (\text{<bit-No.> of <EAd>})$ Sets a specified bit in a general register or memory operand to 1. The bit number is specified by 3-bit immediate data or the lower three bits of a general register.
BCLR	B	$0 \rightarrow (\text{<bit-No.> of <EAd>})$ Clears a specified bit in a general register or memory operand to 0. The bit number is specified by 3-bit immediate data or the lower three bits of a general register.
BNOT	B	$\sim (\text{<bit-No.> of <EAd>}) \rightarrow (\text{<bit-No.> of <EAd>})$ Inverts a specified bit in a general register or memory operand. The bit number is specified by 3-bit immediate data or the lower three bits of a general register.
BTST	B	$\sim (\text{<bit-No.> of <EAd>}) \rightarrow Z$ Tests a specified bit in a general register or memory operand and sets or clears the Z flag accordingly. The bit number is specified by 3-bit immediate data or the lower three bits of a general register.
BAND	B	$C \wedge (\text{<bit-No.> of <EAd>}) \rightarrow C$ ANDs the carry flag with a specified bit in a general register or memory operand and stores the result in the carry flag.
BIAND	B	$C \wedge \sim (\text{<bit-No.> of <EAd>}) \rightarrow C$ ANDs the carry flag with the inverse of a specified bit in a general register or memory operand and stores the result in the carry flag. The bit number is specified by 3-bit immediate data.
BOR	B	$C \vee (\text{<bit-No.> of <EAd>}) \rightarrow C$ ORs the carry flag with a specified bit in a general register or memory operand and stores the result in the carry flag.
BIOR	B	$C \vee \sim (\text{<bit-No.> of <EAd>}) \rightarrow C$ ORs the carry flag with the inverse of a specified bit in a general register or memory operand and stores the result in the carry flag. The bit number is specified by 3-bit immediate data.

Note: \* Size refers to the operand size.

B: Byte

Instruction	Size*	Function
BXOR	B	$C \oplus (\text{<bit-No.> of <EAd>}) \rightarrow C$ Exclusive-ORs the carry flag with a specified bit in a general register or memory operand and stores the result in the carry flag.
BIXOR	B	$C \oplus \sim (\text{<bit-No.> of <EAd>}) \rightarrow C$ Exclusive-ORs the carry flag with the inverse of a specified bit in a general register or memory operand and stores the result in the carry flag. The bit number is specified by 3-bit immediate data.
BLD	B	$(\text{<bit-No.> of <EAd>}) \rightarrow C$ Transfers a specified bit in a general register or memory to the carry flag.
BILD	B	$\sim (\text{<bit-No.> of <EAd>}) \rightarrow C$ Transfers the inverse of a specified bit in a general register or memory operand to the carry flag. The bit number is specified by 3-bit immediate data.
BST	B	$C \rightarrow (\text{<bit-No.> of <EAd>})$ Transfers the carry flag value to a specified bit in a general register or memory operand.
BIST	B	$\sim C \rightarrow (\text{<bit-No.> of <EAd>})$ Transfers the inverse of the carry flag value to a specified bit in a general register or memory operand. The bit number is specified by 3-bit immediate data.

Note:\* Size refers to the operand size.

B: Byte

**Table 2.8 Branch Instructions**

<b>Instruction</b>	<b>Size</b>	<b>Function</b>																																																			
Bcc	–	Branches to a specified address if a specified condition is true. The branching conditions are listed below.																																																			
		<table border="1"> <thead> <tr> <th><b>Mnemonic</b></th> <th><b>Description</b></th> <th><b>Condition</b></th> </tr> </thead> <tbody> <tr> <td>BRA (BT)</td> <td>Always (true)</td> <td>Always</td> </tr> <tr> <td>BRN (BF)</td> <td>Never (false)</td> <td>Never</td> </tr> <tr> <td>BHI</td> <td>High</td> <td><math>C \vee Z = 0</math></td> </tr> <tr> <td>BLS</td> <td>Low or same</td> <td><math>C \vee Z = 1</math></td> </tr> <tr> <td>BCC (BHS)</td> <td>Carry clear (high or same)</td> <td><math>C = 0</math></td> </tr> <tr> <td>BCS (BLO)</td> <td>Carry set (low)</td> <td><math>C = 1</math></td> </tr> <tr> <td>BNE</td> <td>Not equal</td> <td><math>Z = 0</math></td> </tr> <tr> <td>BEQ</td> <td>Equal</td> <td><math>Z = 1</math></td> </tr> <tr> <td>BVC</td> <td>Overflow clear</td> <td><math>V = 0</math></td> </tr> <tr> <td>BVS</td> <td>Overflow set</td> <td><math>V = 1</math></td> </tr> <tr> <td>BPL</td> <td>Plus</td> <td><math>N = 0</math></td> </tr> <tr> <td>BMI</td> <td>Minus</td> <td><math>N = 1</math></td> </tr> <tr> <td>BGE</td> <td>Greater or equal</td> <td><math>N \oplus V = 0</math></td> </tr> <tr> <td>BLT</td> <td>Less than</td> <td><math>N \oplus V = 1</math></td> </tr> <tr> <td>BGT</td> <td>Greater than</td> <td><math>Z \vee (N \oplus V) = 0</math></td> </tr> <tr> <td>BLE</td> <td>Less or equal</td> <td><math>Z \vee (N \oplus V) = 1</math></td> </tr> </tbody> </table>	<b>Mnemonic</b>	<b>Description</b>	<b>Condition</b>	BRA (BT)	Always (true)	Always	BRN (BF)	Never (false)	Never	BHI	High	$C \vee Z = 0$	BLS	Low or same	$C \vee Z = 1$	BCC (BHS)	Carry clear (high or same)	$C = 0$	BCS (BLO)	Carry set (low)	$C = 1$	BNE	Not equal	$Z = 0$	BEQ	Equal	$Z = 1$	BVC	Overflow clear	$V = 0$	BVS	Overflow set	$V = 1$	BPL	Plus	$N = 0$	BMI	Minus	$N = 1$	BGE	Greater or equal	$N \oplus V = 0$	BLT	Less than	$N \oplus V = 1$	BGT	Greater than	$Z \vee (N \oplus V) = 0$	BLE	Less or equal	$Z \vee (N \oplus V) = 1$
<b>Mnemonic</b>	<b>Description</b>	<b>Condition</b>																																																			
BRA (BT)	Always (true)	Always																																																			
BRN (BF)	Never (false)	Never																																																			
BHI	High	$C \vee Z = 0$																																																			
BLS	Low or same	$C \vee Z = 1$																																																			
BCC (BHS)	Carry clear (high or same)	$C = 0$																																																			
BCS (BLO)	Carry set (low)	$C = 1$																																																			
BNE	Not equal	$Z = 0$																																																			
BEQ	Equal	$Z = 1$																																																			
BVC	Overflow clear	$V = 0$																																																			
BVS	Overflow set	$V = 1$																																																			
BPL	Plus	$N = 0$																																																			
BMI	Minus	$N = 1$																																																			
BGE	Greater or equal	$N \oplus V = 0$																																																			
BLT	Less than	$N \oplus V = 1$																																																			
BGT	Greater than	$Z \vee (N \oplus V) = 0$																																																			
BLE	Less or equal	$Z \vee (N \oplus V) = 1$																																																			
JMP	–	Branches unconditionally to a specified address.																																																			
BSR	–	Branches to a subroutine at a specified address																																																			
JSR	–	Branches to a subroutine at a specified address																																																			
RTS	–	Returns from a subroutine																																																			

**Table 2.9 System Control Instruction**

<b>Instruction</b>	<b>Size*</b>	<b>Function</b>
TRAPA	–	Starts trap-instruction exception handling.
RTE	–	Returns from an exception-handling routine.
SLEEP	–	Causes a transition to a power-down state.
LDC	B/W	(EAs) → CCR, (EAs) → EXR Moves the source operand contents or immediate data to CCR or EXR. Although CCR and EXR are 8-bit registers, word-size transfers are performed between them and memory. The upper 8 bits are valid.
STC	B/W	CCR → (EAd), EXR → (EAd) Transfers CCR or EXR contents to a general register or memory. Although CCR and EXR are 8-bit registers, word-size transfers are performed between them and memory. The upper 8 bits are valid.
ANDC	B	CCR ∧ #IMM → CCR, EXR ∧ #IMM → EXR Logically ANDs the CCR or EXR contents with immediate data.
ORC	B	CCR ∨ #IMM → CCR, EXR ∨ #IMM → EXR Logically ORs the CCR or EXR contents with immediate data.
XORC	B	CCR ⊕ #IMM → CCR, EXR ⊕ #IMM → EXR Logically exclusive-ORs the CCR or EXR contents with immediate data.
NOP	–	PC + 2 → PC Only increments the program counter.

Note:\* Size refers to the operand size.

B: Byte

W: Word

**Table 2.10 Block Data Transfer Instruction**

<b>Instruction</b>	<b>Size</b>	<b>Function</b>
EEPMOV.B	–	if R4L $\neq$ 0 then Repeat @ER5+ $\rightarrow$ @ER6+ R4L–1 $\rightarrow$ R4L Until R4L = 0 else next;
EEPMOV.W	–	if R4 $\neq$ 0 then Repeat @ER5+ $\rightarrow$ @ER6+ R4–1 $\rightarrow$ R4 Until R4 = 0 else next;

Transfer a data block. Starting from the address set in ER5, transfers data for the number of bytes set in R4L or R4 to the address location set in ER6.

Execution of the next instruction begins as soon as the transfer is completed.

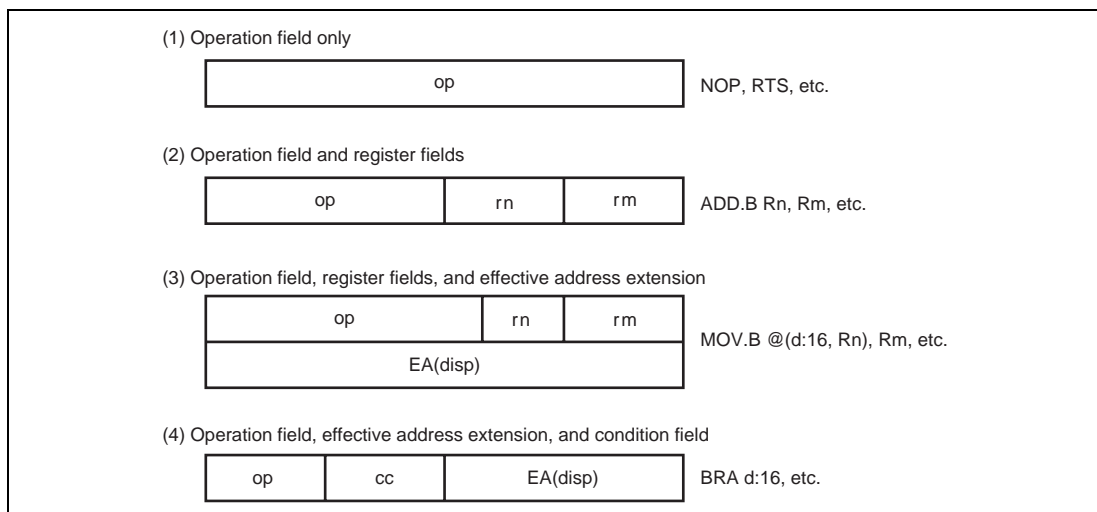


## 2.6.2 Basic Instruction Formats

The H8S/2000 CPU instructions consist of 2-byte (1-word) units. An instruction consists of an operation field (op), a register field (r), an effective address extension (EA), and a condition field (cc).

Figure 2.11 shows examples of instruction formats.

- **Operation Field**  
Indicates the function of the instruction, the addressing mode, and the operation to be carried out on the operand. The operation field always includes the first four bits of the instruction. Some instructions have two operation fields.
- **Register Field**  
Specifies a general register. Address registers are specified by 3 bits, data registers by 3 bits or 4 bits. Some instructions have two register fields. Some have no register field.
- **Effective Address Extension**  
8, 16, or 32 bits specifying immediate data, an absolute address, or a displacement.
- **Condition Field**  
Specifies the branching condition of Bcc instructions.



**Figure 2.11 Instruction Formats (Examples)**

## 2.7 Addressing Modes and Effective Address Calculation

The H8S/2000 CPU supports the eight addressing modes listed in table 2.11. Each instruction uses a subset of these addressing modes. Arithmetic and logic instructions can use the register direct and immediate modes. Data transfer instructions can use all addressing modes except program-counter relative and memory indirect. Bit manipulation instructions use register direct, register indirect, or absolute addressing mode to specify an operand, and register direct (BSET, BCLR, BNOT, and BTST instructions) or immediate (3-bit) addressing mode to specify a bit number in the operand.

**Table 2.11 Addressing Modes**

No.	Addressing Mode	Symbol
1	Register direct	Rn
2	Register indirect	@ERn
3	Register indirect with displacement	@(d:16,ERn)/@(d:32,ERn)
4	Register indirect with post-increment Register indirect with pre-decrement	@ERn+ @-ERn
5	Absolute address	@aa:8/@aa:16/@aa:24/@aa:32
6	Immediate	#xx:8/#xx:16/#xx:32
7	Program-counter relative	@(d:8,PC)/@(d:16,PC)
8	Memory indirect	@@aa:8

### 2.7.1 Register Direct—Rn

The register field of the instruction specifies an 8-, 16-, or 32-bit general register containing the operand. R0H to R7H and R0L to R7L can be specified as 8-bit registers. R0 to R7 and E0 to E7 can be specified as 16-bit registers. ER0 to ER7 can be specified as 32-bit registers.

### 2.7.2 Register Indirect—@ERn

The register field of the instruction code specifies an address register (ERn) which contains the address of the operand on memory. If the address is a program instruction address, the lower 24 bits are valid and the upper 8 bits are all assumed to be 0 (H'00).

### 2.7.3 Register Indirect with Displacement— $@(d:16, ERn)$ or $@(d:32, ERn)$

A 16-bit or 32-bit displacement contained in the instruction is added to an address register ( $ERn$ ) specified by the register field of the instruction, and the sum gives the address of a memory operand. A 16-bit displacement is sign-extended when added.

### 2.7.4 Register Indirect with Post-Increment or Pre-Decrement— $@ERn+$ or $@-ERn$

**Register Indirect with Post-Increment— $@ERn+$ :** The register field of the instruction code specifies an address register ( $ERn$ ) which contains the address of a memory operand. After the operand is accessed, 1, 2, or 4 is added to the address register contents and the sum is stored in the address register. The value added is 1 for byte access, 2 for word transfer instruction, or 4 for longword transfer instruction. For word or longword transfer instruction, the register value should be even.

**Register Indirect with Pre-Decrement— $@-ERn$ :** The value 1, 2, or 4 is subtracted from an address register ( $ERn$ ) specified by the register field in the instruction code, and the result becomes the address of a memory operand. The result is also stored in the address register. The value subtracted is 1 for byte access, 2 for word transfer instruction, or 4 for longword transfer instruction. For word or longword transfer instruction, the register value should be even.

### 2.7.5 Absolute Address— $@aa:8$ , $@aa:16$ , $@aa:24$ , or $@aa:32$

The instruction code contains the absolute address of a memory operand. The absolute address may be 8 bits long ( $@aa:8$ ), 16 bits long ( $@aa:16$ ), 24 bits long ( $@aa:24$ ), or 32 bits long ( $@aa:32$ ). Table 2.12 indicates the accessible absolute address ranges.

To access data, the absolute address should be 8 bits ( $@aa:8$ ), 16 bits ( $@aa:16$ ), or 32 bits ( $@aa:32$ ) long. For an 8-bit absolute address, the upper 24 bits are all assumed to be 1 (H'FFFF). For a 16-bit absolute address the upper 16 bits are a sign extension. A 32-bit absolute address can access the entire address space.

A 24-bit absolute address ( $@aa:24$ ) indicates the address of a program instruction. The upper 8 bits are all assumed to be 0 (H'00).

**Table 2.12 Absolute Address Access Ranges**

<b>Absolute Address</b>		<b>Normal Mode*</b>	<b>Advanced Mode</b>
Data address	8 bits (@aa:8)	H'FF00 to H'FFFF	H'FFFF00 to H'FFFFFF
	16 bits (@aa:16)	H'0000 to H'FFFF	H'000000 to H'007FFF, H'FF8000 to H'FFFFFF
	32 bits (@aa:32)		H'000000 to H'FFFFFF
Program instruction address	24 bits (@aa:24)		

Note: \* Not available in this LSI.

### 2.7.6 Immediate—#xx:8, #xx:16, or #xx:32

The instruction contains 8-bit (#xx:8), 16-bit (#xx:16), or 32-bit (#xx:32) immediate data as an operand.

The ADDS, SUBS, INC, and DEC instructions contain immediate data implicitly. Some bit manipulation instructions contain 3-bit immediate data in the instruction code, specifying a bit number. The TRAPA instruction contains 2-bit immediate data in its instruction code, specifying a vector address.

### 2.7.7 Program-Counter Relative—@(d:8, PC) or @(d:16, PC)

This mode is used in the Bcc and BSR instructions. An 8-bit or 16-bit displacement contained in the instruction is sign-extended and added to the 24-bit PC contents to generate a branch address.

Only the lower 24 bits of this branch address are valid; the upper 8 bits are all assumed to be 0 (H'00). The PC value to which the displacement is added is the address of the first byte of the next instruction, so the possible branching range is -126 to +128 bytes (-63 to +64 words) or -32766 to +32768 bytes (-16383 to +16384 words) from the branch instruction. The resulting value should be an even number.

### 2.7.8 Memory Indirect—@@aa:8

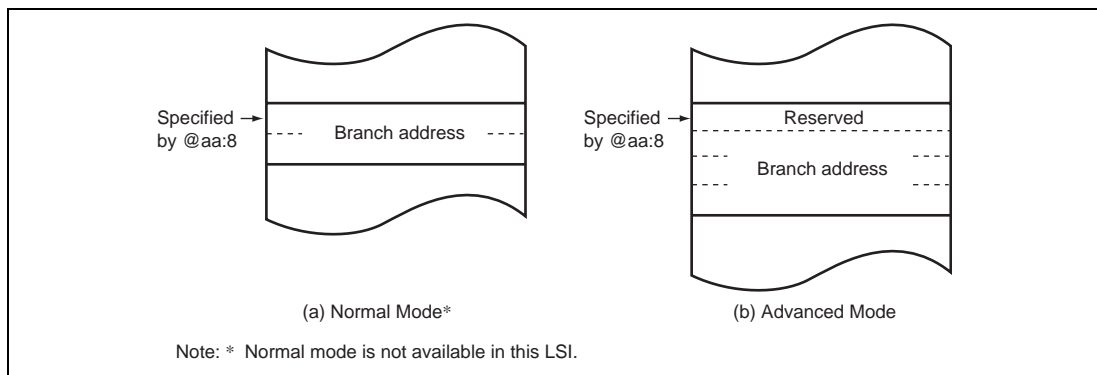
This mode can be used by the JMP and JSR instructions. The instruction code contains an 8-bit absolute address specifying a memory operand. This memory operand contains a branch address.

The upper bits of the absolute address are all assumed to be 0, so the address range is 0 to 255 (H'0000 to H'00FF in normal mode\*, H'000000 to H'0000FF in advanced mode). In normal mode the memory operand is a word operand and the branch address is 16 bits long. In advanced mode the memory operand is a longword operand, the first byte of which is assumed to be H'00.

Note that the first part of the address range is also the exception vector area. For further details, refer to section 4, Exception Handling.

If an odd address is specified in word or longword memory access, or as a branch address, the least significant bit is regarded as 0, causing data to be accessed or instruction code to be fetched at the address preceding the specified address. (For further information, see section 2.5.2, Memory Data Formats.)

Note: \* Not available in this LSI.

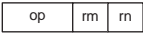
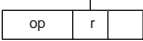

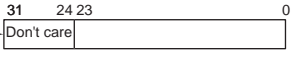

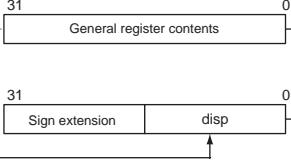

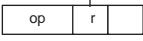
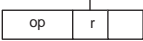
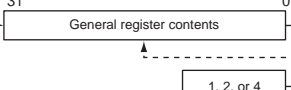
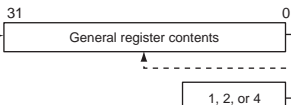

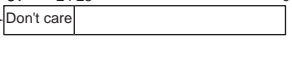


**Figure 2.12 Branch Address Specification in Memory Indirect Mode**

## 2.7.9 Effective Address Calculation

Table 2.13 indicates how effective addresses are calculated in each addressing mode. In normal mode the upper 8 bits of the effective address are ignored in order to generate a 16-bit address.

**Table 2.13 Effective Address Calculation**

No	Addressing Mode and Instruction Format	Effective Address Calculation	Effective Address (EA)								
1	Register direct (Rn) 		Operand is general register contents.								
2	Register indirect (@ERn) 										
3	Register indirect with displacement @d:(d:16,ERn) or @:(d:32,ERn) 										
4	Register indirect with post-increment or pre-decrement •Register indirect with post-increment @ERn+  •Register indirect with pre-decrement @-ERn 	  <table border="1" data-bbox="463 970 704 1050"> <thead> <tr> <th>Operand Size</th> <th>Offset</th> </tr> </thead> <tbody> <tr> <td>Byte</td> <td>1</td> </tr> <tr> <td>Word</td> <td>2</td> </tr> <tr> <td>Longword</td> <td>4</td> </tr> </tbody> </table>	Operand Size	Offset	Byte	1	Word	2	Longword	4	 
Operand Size	Offset										
Byte	1										
Word	2										
Longword	4										

No	Addressing Mode and Instruction Format	Effective Address Calculation	Effective Address (EA)
5	Absolute address @aa:8 		
	@aa:16 		
	@aa:24 		
	@aa:32 		
6	Immediate #xx:8/#xx:16/#xx:32 		Operand is immediate data.
7	Program-counter relative @(d:8,PC)/@(d:16,PC) 		
8	Memory indirect @aa:8 •Normal mode* 		
	•Advanced mode 		

Note: \* Normal mode is not available in this LSI.

## 2.8 Processing States

The H8S/2000 CPU has five main processing states: the reset state, exception handling state, program execution state, bus-released state, and power-down state. Figure 2.13 indicates the state transitions.

- **Reset State**

In this state the CPU and internal peripheral modules are all initialized and stop. When the  $\overline{\text{RES}}$  input goes low all current processing stops and the CPU enters the reset state. All interrupts are masked in the reset state. Reset exception handling starts when the  $\overline{\text{RES}}$  signal changes from low to high. For details, refer to section 4, Exception Handling.

The reset state can also be entered by a watchdog timer overflow.

- **Exception-Handling State**

The exception-handling state is a transient state that occurs when the CPU alters the normal processing flow due to an exception source, such as, a reset, trace, interrupt, or trap instruction. The CPU fetches a start address (vector) from the exception vector table and branches to that address. For further details, refer to section 4, Exception Handling.

- **Program Execution State**

In this state the CPU executes program instructions in sequence.

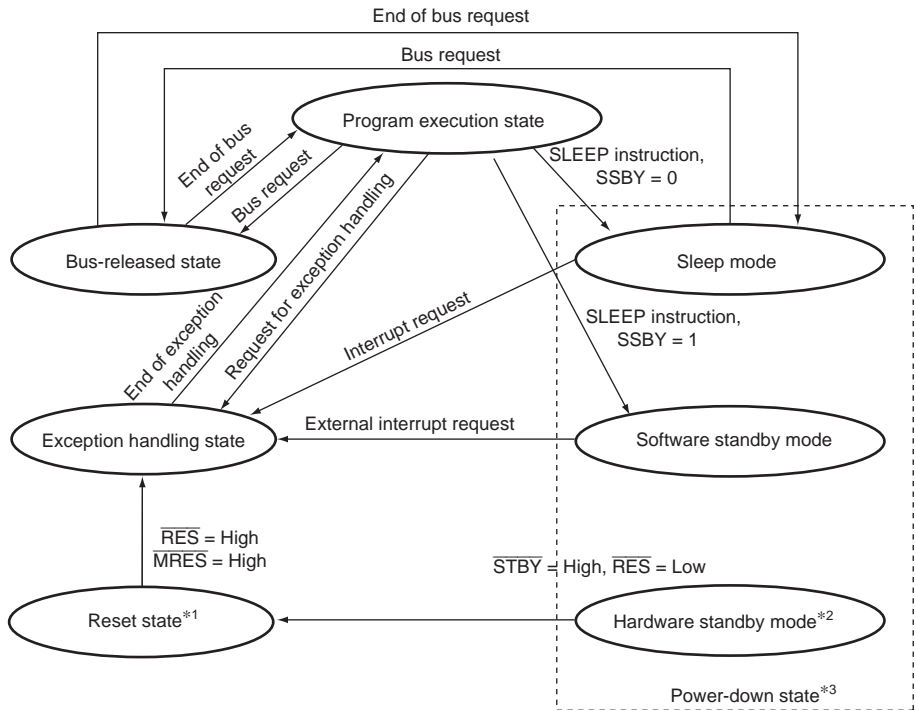
- **Bus-Released State**

In a product which has a bus master other than the CPU, such as a direct memory access controller (DMAC) and a data transfer controller (DTC), the bus-released state occurs when the bus has been released in response to a bus request from a bus master other than the CPU. While the bus is released, the CPU halts operations.

- **Power-Down State**

This is a power-down state in which the CPU stops operating. The program stop state occurs when a SLEEP instruction is executed or the CPU enters hardware standby mode. For details, refer to section 20, Power-Down Modes.





- Notes:
1. From any state except hardware standby mode, a transition to the reset state occurs whenever  $\overline{RES}$  goes low. A transition can also be made to the reset state when the watchdog timer overflows. From any state except hardware standby mode and power-on reset state, a transition to the manual reset state occurs whenever  $\overline{MRES}$  goes low.
  2. From any state, a transition to hardware standby mode occurs when  $\overline{STBY}$  goes low.
  3. Apart from these states, there are also the watch mode, subactive mode, and the subsleep mode. See section 20, Power-Down Modes.

**Figure 2.13 State Transitions**

## 2.9 Usage Notes

### 2.9.1 Note on TAS Instruction Usage

Only register ER0, ER1, ER4, or ER5 should be used when using the TAS instruction. The TAS instruction is not generated by the Renesas Technology H8S and H8/300 Series C/C++ compilers. If the TAS instruction is used as a user-defined intrinsic function, ensure that only register ER0, ER1, ER4, or ER5 is used.

### 2.9.2 STM/LTM Instruction Usage

With the STM or LDM instruction, the ER7 register is used as the stack pointer, and thus cannot be used as a register that allows save (STM) or restore (LDM) operation.

With a single STM or LDM instruction, two to four registers can be saved or restored. The available registers are as follows:

For two registers: ER0 and ER1, ER2 and ER3, or ER4 and ER5

For three registers: ER0 to ER2, or ER4 to ER6

For four registers: ER0 to ER3

For the Renesas Technology H8S or H8/300 Series C/C++ Compiler, the STM/LDM instruction including ER7 is not created.

### 2.9.3 Note on Bit Manipulation Instructions

Using bit manipulation instructions on registers containing write-only bits can result in the bits that should have been manipulated not being manipulated as intended or in the wrong bits being manipulated.

Reading data from a register containing write-only bits may return fixed or undefined values. Consequently, bit manipulation instructions that use the read values to perform operations (BNOT, BTST, BAND, BIAND, BOR, BIOR, BXOR, BIXOR, BLD, and BILD) will not work properly.

In addition, bit manipulation instructions that write data following operations based on the data values read (BSET, BCLR, BNOT, BST, and BIST) may change the values of bits unrelated to the intended bit manipulation. Therefore, caution is necessary when using bit manipulation instructions on registers containing write-only bits.

The instructions BSET, BCLR, BNOT, BST, and BIST perform the following operations in the order shown:

1. Read data in byte units
2. Perform bit manipulation on the read data according to the instruction
3. Write data in byte units

Example: Using the BCLR instruction to clear pin 14 only of P1DDR for port 1

P1DDR is an 8-bit register that contains write-only bits. It is used to specify the I/O setting of the individual pins in port 1. Reading produces invalid data. Attempting to read from P1DDR returns undefined values.

In this example, the BCLR instruction is used to set pin 14 as an input port. Let us assume that pins 17 to 14 are presently set as output pins and pins 13 to 10 are set as input pins. Thus, the value of P1DDR is initially H'F0.

	<b>P17</b>	<b>P16</b>	<b>P15</b>	<b>P14</b>	<b>P13</b>	<b>P12</b>	<b>P11</b>	<b>P10</b>
I/O	Output	Output	Output	Output	Input	Input	Input	Input
P1DDR	1	1	1	1	0	0	0	0

To change pin 14 from an output pin to an input pin, the value of bit 4 in P1DDR must be changed from 1 to 0 (H'F0 to H'E0). Now assume that the BCLR instruction is used to clear bit 4 in P1DDR to 0.

```
BCLR    #4, @P1DDR
```

However, using the above bit manipulation instruction on the write-only register P1DDR can cause problems, as described below.

The BCLR instruction first reads data from P1DDR in byte units, but in this case the read values are undefined. These undefined values can be 0 or 1 for each bit in the register, but there is no way of telling which. Since all of the bits in P1DDR are write-only, undefined values are returned for all of the bits when the register is read. In this example the value of P1DDR is H'F0, but we will assume that the value returned when the register was read is H'F8, which would give bit 3 a value of 1.

	P17	P16	P15	P14	P13	P12	P11	P10
I/O	Output	Output	Output	Output	Input	Input	Input	Input
P1DDR	1	1	1	1	0	0	0	0
Read value	1	1	1	1	1	0	0	0

The BCLR instruction performs bit manipulation on the read value, which is H'F8 in this example. It clears bit 4 to 0.

	P17	P16	P15	P14	P13	P12	P11	P10
I/O	Output	Output	Output	Output	Input	Input	Input	Input
P1DDR	1	1	1	1	0	0	0	0
After bit manipulation	1	1	1	0	1	0	0	0

Following bit manipulation the data is written to P1DDR and the BCLR instruction terminates.

	P17	P16	P15	P14	P13	P12	P11	P10
I/O	Output	Output	Output	Input	Output	Input	Input	Input
P1DDR	1	1	1	0	1	0	0	0
Write value	1	1	1	0	1	0	0	0

The contents of P1DDR should have been overwritten with a value of H'E0, but in fact a value of H'E8 was written to the register. This changed pin 13, which should have been an input pin, to an output pin. In this example we assumed that the value of bit 1 in P1DDR was 1. However, since the values of bits 7 to 0 in P1DDR are all undefined when read, there is the possibility that individual bit values could be changed from 0 to 1 or from 1 to 0. To prevent this from happening, the recommendations in section 2.9.4, Accessing Registers Containing Write-Only Bits, should be followed when changing the values of registers containing write-only bits.

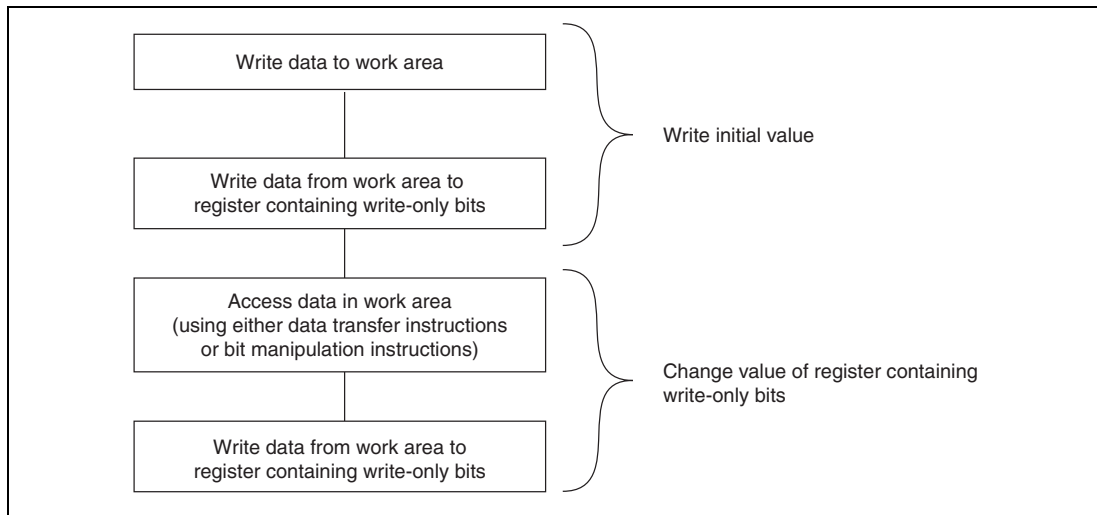
In addition, the BCLR instruction can be used to clear flags in internal I/O registers to 0. In such cases it is not necessary to read the relevant flag beforehand so long as it is clear that it has been set to 1 by an interrupt processing routine or the like.

#### 2.9.4 Accessing Registers Containing Write-Only Bits

Using data transfer instructions or bit manipulation instructions on registers containing write-only bits can result in undefined values being read. To prevent the reading of undefined values, the procedure described below should be used to access registers containing write-only bits.

In order to write to a register containing write-only bits, set aside a work area in memory (in on-chip RAM, for example) and write the data to be manipulated to it. After accessing and manipulating the data in the work area in memory, write the resulting data to the register containing write-only bits.

Figure 2.14 Example Flowchart of Method for Accessing Registers Containing Write-Only Bits



**Figure 2.14 Flowchart of Method for Accessing Registers Containing Write-Only Bits**

Example: Clearing pin 14 only of P1DDR for port 1

P1DDR is an 8-bit register that contains write-only bits. It is used to specify the I/O setting of the individual pins in port 1. Reading produces invalid data. Attempting to read from P1DDR returns undefined values.

In this example, the BCLR instruction is used to set pin 14 as an input port. To start, the initial value H'F0 to be written to P1DDR is written ahead of time to the work area (RAM0) in memory.

```

MOV.B    #H'F0,  R0L
MOV.B    R0L,    @RAM0
MOV.B    R0L,    @P1DDR
  
```

	P17	P16	P15	P14	P13	P12	P11	P10
I/O	Output	Output	Output	Output	Input	Input	Input	Input
P1DDR	1	1	1	1	0	0	0	0
RAM0	1	1	1	1	0	0	0	0

To change pin 14 from an output pin to an input pin, the value of bit 4 in P1DDR must be changed from 1 to 0 (H'F0 to H'E0). Here the BCLR instruction will be used to clear bit 4 in P1DDR to 0.

```
BCLR    #4,    @RAM0
```

	P17	P16	P15	P14	P13	P12	P11	P10
I/O	Output	Output	Output	Output	Input	Input	Input	Input
P1DDR	1	1	1	1	0	0	0	0
RAM0	1	1	1	0	0	0	0	0

Since RAM0 is a read/write area of memory, performing the above bit manipulation using the BCLR instruction causes only bit 4 in RAM0 to be cleared to 0. The value of RAM0 is then written to P1DDR.

```
MOV.B   @RAM0,  R0L
MOV.B   R0L,    @P1DDR
```

	P17	P16	P15	P14	P13	P12	P11	P10
I/O	Output	Output	Output	Input	Input	Input	Input	Input
P1DDR	1	1	1	0	0	0	0	0
RAM0	1	1	1	0	0	0	0	0

By using the above procedure to access registers containing write-only bits, it is possible to create programs that are not dependent on the type of instructions used.

## Section 3 MCU Operating Modes

### 3.1 Operating Mode Selection

This LSI supports four operating modes (modes 4 to 7). These modes enable selection of the CPU operating mode, enabling/disabling of on-chip ROM, and the initial bus width setting, by setting the mode pins (MD2 to MD0) as show in table 3.1. Modes 4 to 6 are external extended modes that allow access to the external memory and peripheral devices. In external extended mode, 8-bit or 16-bit address space can be set for each area depending on the bus controller setting after program execution starts. If 16-bit access is selected for any one area, 16-bit bus mode is set; if 8-bit access is selected for all areas, 8-bit bus mode is set. In mode 7, the external address space cannot be used. Do not change the mode pin settings during operation. Only mode 7 is available in the H8S/2212 Group.

**Table 3.1 MCU Operating Mode Selection**

MCU Operating Mode	MD2	MD1	MD0	CPU Operating Mode	Description	On-chip ROM	External Data Bus	
							Initial Value	Maximum Value
4	1	0	0	Advanced mode	On-chip ROM disabled, extended mode	Disabled	16 bits	16 bits
5	1	0	1	Advanced mode	On-chip ROM disabled, extended mode	Disabled	8 bits	16 bits
6	1	1	0	Advanced mode	On-chip ROM enabled, extended mode	Enabled	8 bits	16 bits
7	1	1	1	Advanced mode	Single-chip mode	Enabled	–	–

Note: When using the E6000 emulator:

- Mode 7 is not available in the H8S/2218 Group. (The E6000 emulator does not support mode 7.)
- Note following restrictions to use the RTC and USB in mode 6.  
Specify PFCR so that A9 and A8 are output on the PB1 and PB0 pins.  
Set H'FF in PCDDR so that A7 to A0 are output on the PC7 to PC0 pins.

## 3.2 Register Descriptions

The following registers are related to the operating mode.

- Mode control register (MDCR)
- System control register (SYSCR)

### 3.2.1 Mode Control Register (MDCR)

MDCR is used to monitor the current operating mode of this LSI. MDCR should not be modified.

Bit	Bit Name	Initial Value	R/W	Description
7 to 4	—	Undefined	—	Reserved These bits are always read as undefined value and cannot be modified.
3	FWE	—* <sup>1</sup>	R	Flash Programming Enable Reflects the input level at the FWE pin. This bit functions same as the FWE bit in the FLMCR1 register.
2	MDS2	—* <sup>1</sup>	R	Mode Select 2 to 0
1	MDS1	—* <sup>1</sup>	R	These bits indicate the input levels at pins MD2 to MD0 (the current operating mode). Bits MDS2 to MDS0 correspond to MD2 to MD0. MDS2 to MDS0 are read-only bits and they cannot be written to. The mode pin (MD2 to MD0) input levels are latched into these bits when MDCR is read.  These latches are canceled by a power-on reset, but maintained at manual reset* <sup>2</sup> .
0	MDS0	—* <sup>1</sup>	R	

Notes: 1. Determined by the FWE and MD2 to MD0 pin settings.  
2. Supported only by the H8S/2218 Group.

### 3.2.2 System Control Register (SYSCR)

SYSCR is used to select the interrupt control mode and the detected edge for NMI, select the MRES input pin\* enable or disable, and enables or disables on-chip RAM.



Bit	Bit Name	Initial Value	R/W	Description
7	–	0	R/W	Reserved The write value should always be 0.
6	–	0	–	Reserved This bit is always read as 0 and cannot be modified.
5	INTM1	0	R/W	These bits select the control mode of the interrupt controller. For details of the interrupt control modes, see section 5.6, Interrupt Control Modes and Interrupt Operation. 00: Interrupt control mode 0 01: Setting prohibited 10: Interrupt control mode 2 11: Setting prohibited
4	INTM0	0	R/W	
3	NMIEG	0	R/W	NMI Edge Select Selects the valid edge of the NMI interrupt input. 0: An interrupt is requested at the falling edge of NMI input 1: An interrupt is requested at the rising edge of NMI input
2	MRESE	0	R/W	Manual Reset Select Enables or disables the $\overline{\text{MRES}}$ pin* input. 0: Manual reset is disabled 1: Manual reset is enabled The $\overline{\text{MRES}}$ input pin* can be used.
1	–	0	–	Reserved This bit is always read as 0 and cannot be modified.
0	RAME	1	R/W	RAM Enable Enables or disables the on-chip RAM. The RAME bit is initialized when the reset status is released. 0: On-chip RAM is disabled 1: On-chip RAM is enabled

Note: \* Supported only by the H8S/2218 Group.

## 3.3 Operating Mode Descriptions

### 3.3.1 Mode 4 (Supported Only by the H8S/2218 Group)

The CPU can access a 16-Mbyte address space in advanced mode. The on-chip ROM is disabled.

Pins P13 to P10, and ports A, B, and C function as an address bus, ports D and E function as a data bus, and part of port F carries bus control signals.

Pins P13 to P11 function as input ports immediately after a reset. Pin 10 and ports A and B function as address (A20 to A8) outputs immediately after a reset. Address (A23 to A21) output can be enabled or disabled by bits AE3 to AE0 in the pin function control register (PFCR) regardless of the corresponding data direction register (DDR) values. Pins for which address output is disabled among pins P13 to P10 and in ports A and B become port outputs when the corresponding DDR bits are set to 1.

Port C always has an address (A7 to A0) output function.

The initial bus mode after a reset is 16 bits, with 16-bit access to all areas. However, note that if 8-bit access is designated by the bus controller for all areas, the bus mode switches to 8 bits.

### 3.3.2 Mode 5 (Supported Only by the H8S/2218 Group)

The CPU can access a 16-Mbyte address space in advanced mode. The on-chip ROM is disabled.

Pins P13 to P10, and ports A, B, and C function as an address bus, ports D and E function as a data bus, and part of port F carries bus control signals.

Pins P13 to P11 function as input ports immediately after a reset. Pin 10 and ports A and B function as address (A20 to A8) outputs immediately after a reset. Address (A23 to A21) output can be enabled or disabled by bits AE3 to AE0 in the pin function control register (PFCR) regardless of the corresponding data direction register (DDR) values. Pins for which address output is disabled among pins P13 to P10 and in ports A and B become port outputs when the corresponding DDR bits are set to 1.

Port C always has an address (A7 to A0) output function.

The initial bus mode after a reset is 8 bits, with 8-bit access to all areas. However, note that if 16-bit access is designated by the bus controller for any area, the bus mode switches to 16 bits and port E becomes a data bus.

### 3.3.3 Mode 6 (Supported Only by the H8S/2218 Group)

The CPU can access a 16-Mbyte address space in advanced mode. The on-chip ROM is enabled.

Pins P13 to P10, and ports A, B and C function as input ports immediately after a reset. Address (A23 to A8) output can be enabled or disabled by bits AE3 to AE0 in the pin function control register (PFCR) regardless of the corresponding data direction register (DDR) values. Pins for which address output is disabled among pins P13 to P10 and in ports A and B become port outputs when the corresponding DDR bits are set to 1.

Port C is an input port immediately after a reset. Addresses A7 to A0 are output by setting the corresponding DDR bits to 1.

Ports D and E function as a data bus, and part of port F carries data bus signals.

The initial bus mode after a reset is 8 bits, with 8-bit access to all areas. However, note that if 16-bit access is designated by the bus controller for any area, the bus mode switches to 16 bits and port E becomes a data bus.

### 3.3.4 Mode 7

The CPU can access a 16-Mbyte address space in advanced mode. The on-chip ROM is enabled, but external addresses cannot be accessed.

All I/O ports are available for use as input-output ports.

### 3.3.5 Pin Functions

The pin functions of ports 1, and A to F vary depending on the operating mode. Table 3.2 shows their functions in each operating mode.

**Table 3.2 Pin Functions in Each Operating Mode**

Port		Mode 4	Mode 5	Mode 6	Mode 7
Port 1	P13 to P11	P*/A	P*/A	P*/A	P
	P10	P/A*	P/A*	P*/A	P
Port A	PA3 to PA0	P/A*	P/A*	P*/A	P
Port B		P/A*	P/A*	P*/A	P
Port C		A	A	P*/A	P
Port D		D	D	D	P
Port E		P/D*	P*/D	P*/D	P
Port F	PF7	P/C*	P/C*	P/C*	P*/C
	PF6 to PF4	C	C	C	P
	PF3	P/C*	P*/C	P*/C	
	PF2 to PF0	P*/C	P*/C	P*/C	

Legend:

P: I/O port

A: Address bus output

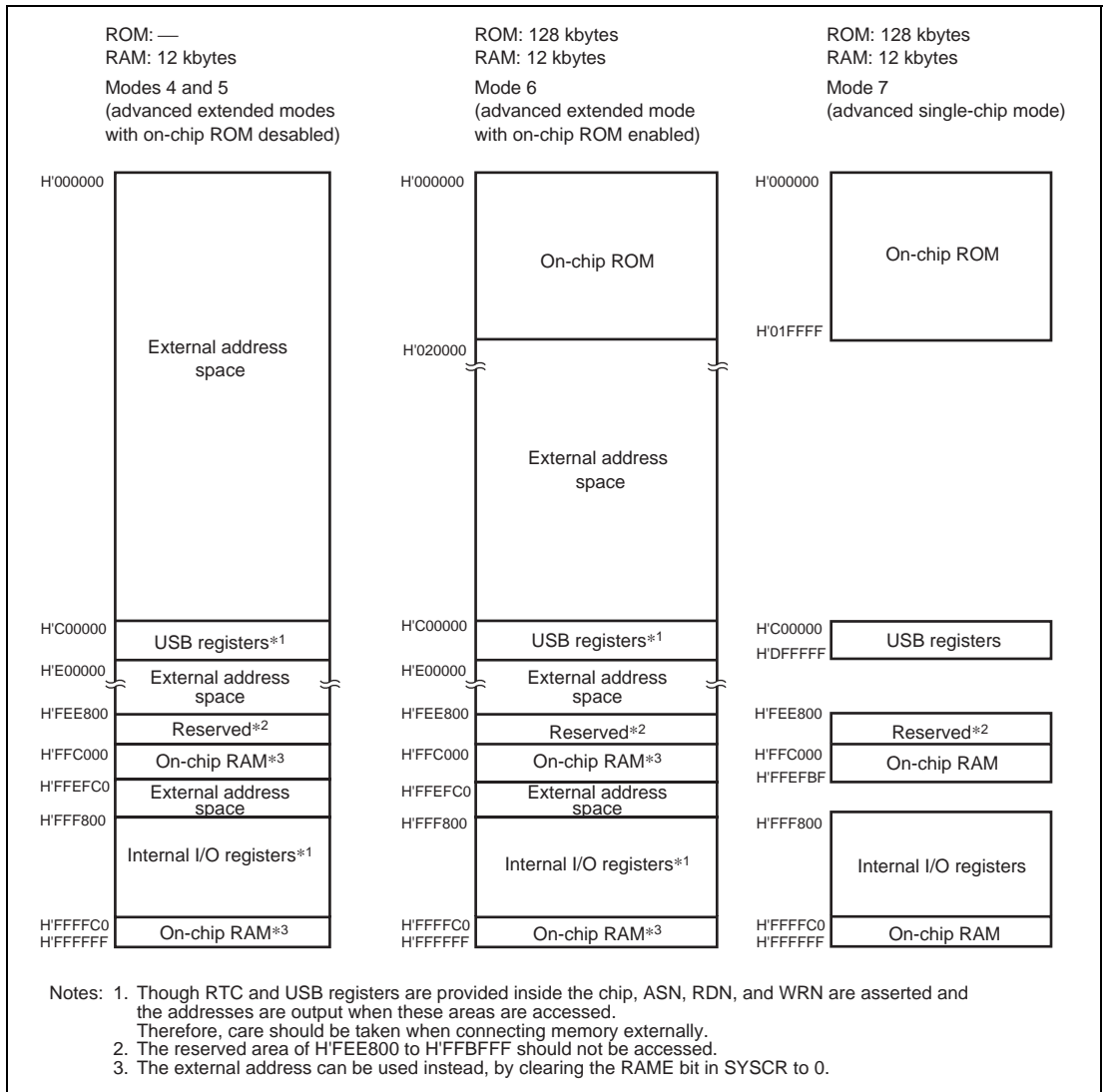
D: Data bus I/O

C: Control signals, clock I/O

\*: After reset

### 3.4 Memory Map in Each Operating Mode

Figures 3.1 to 3.4 show the memory map in each operation mode, respectively.



**Figure 3.1 Memory Map in Each Operating Mode for HD64F2218, HD64F2218U and HD64F2218CU**

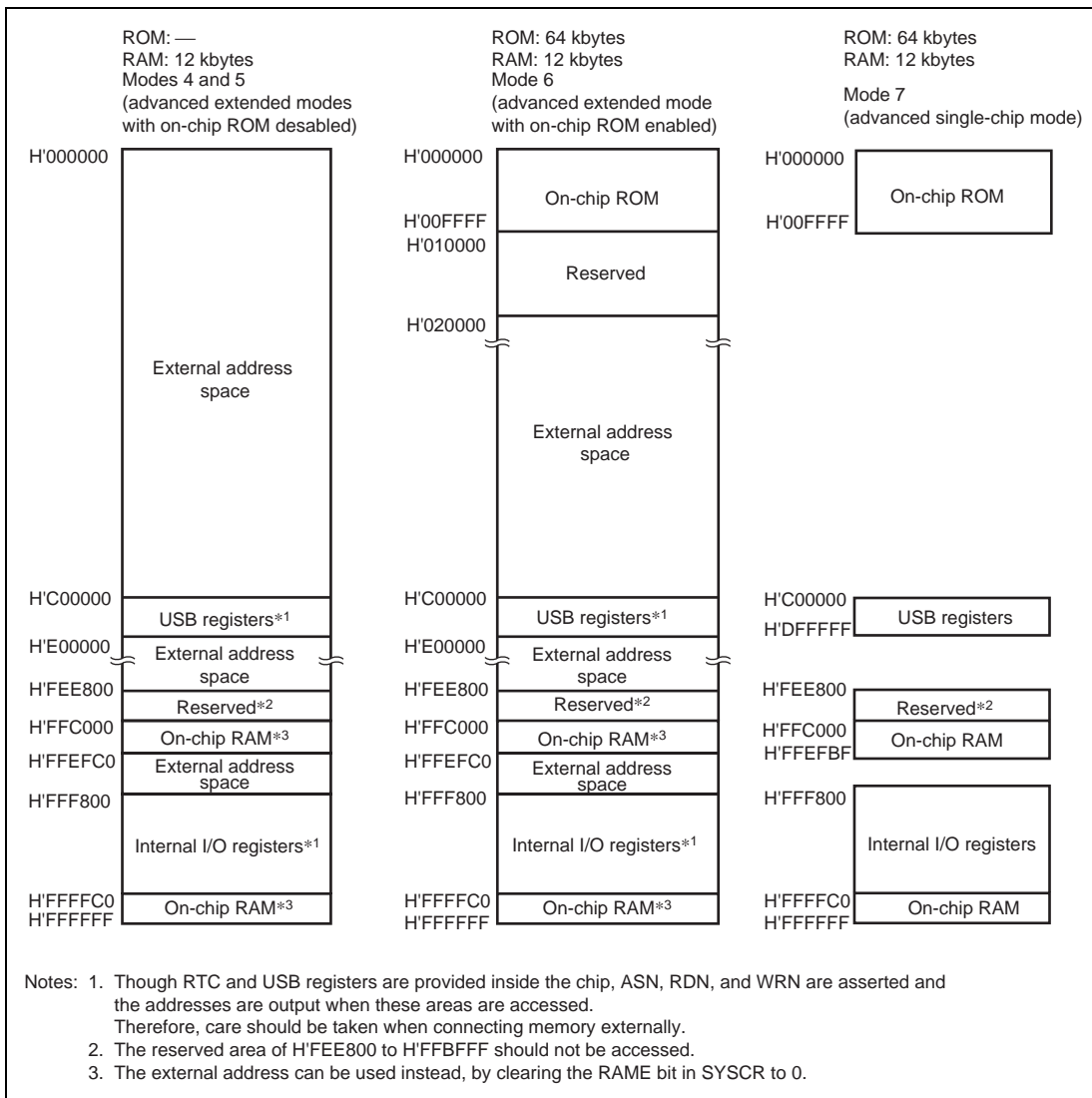
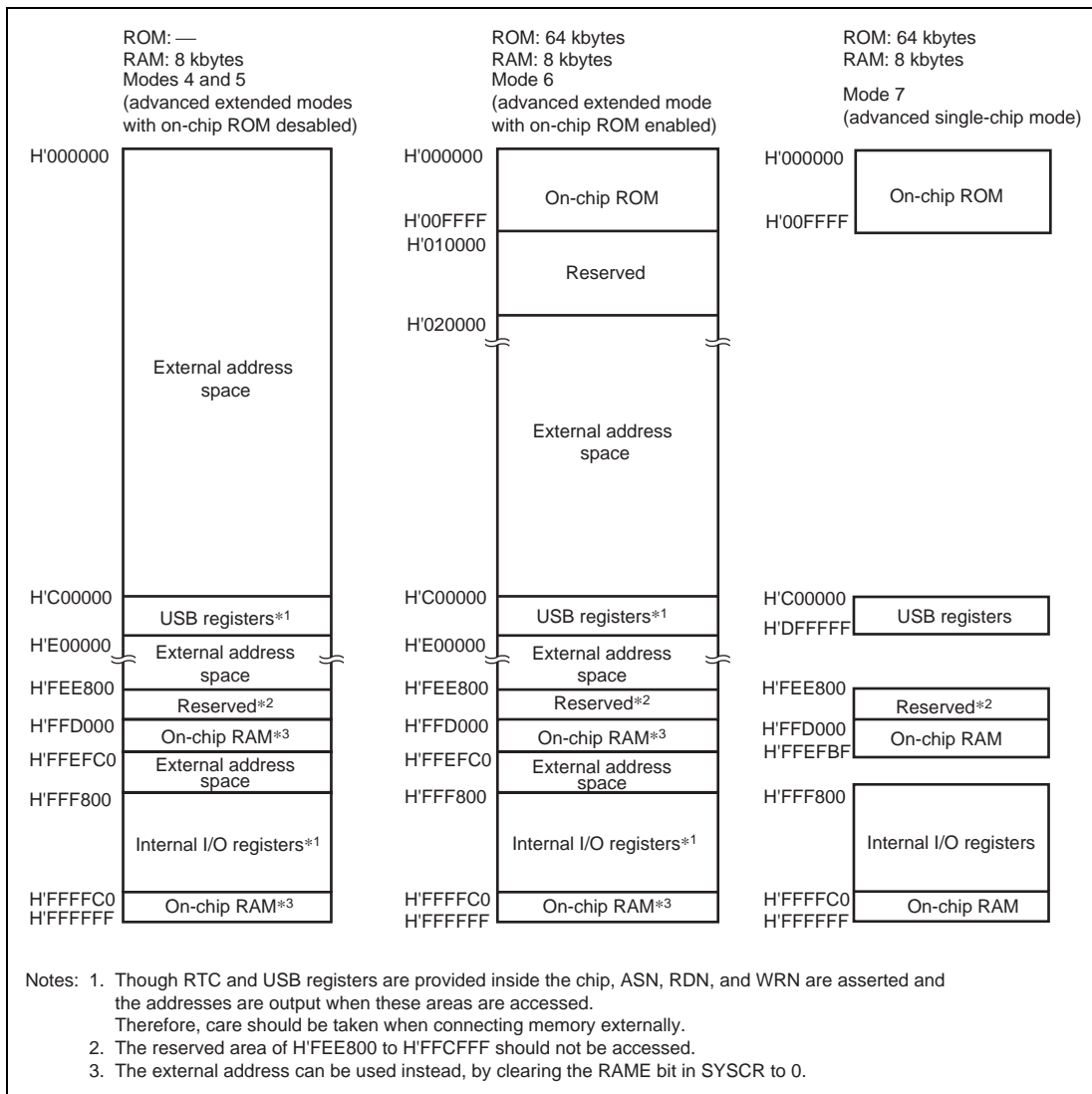
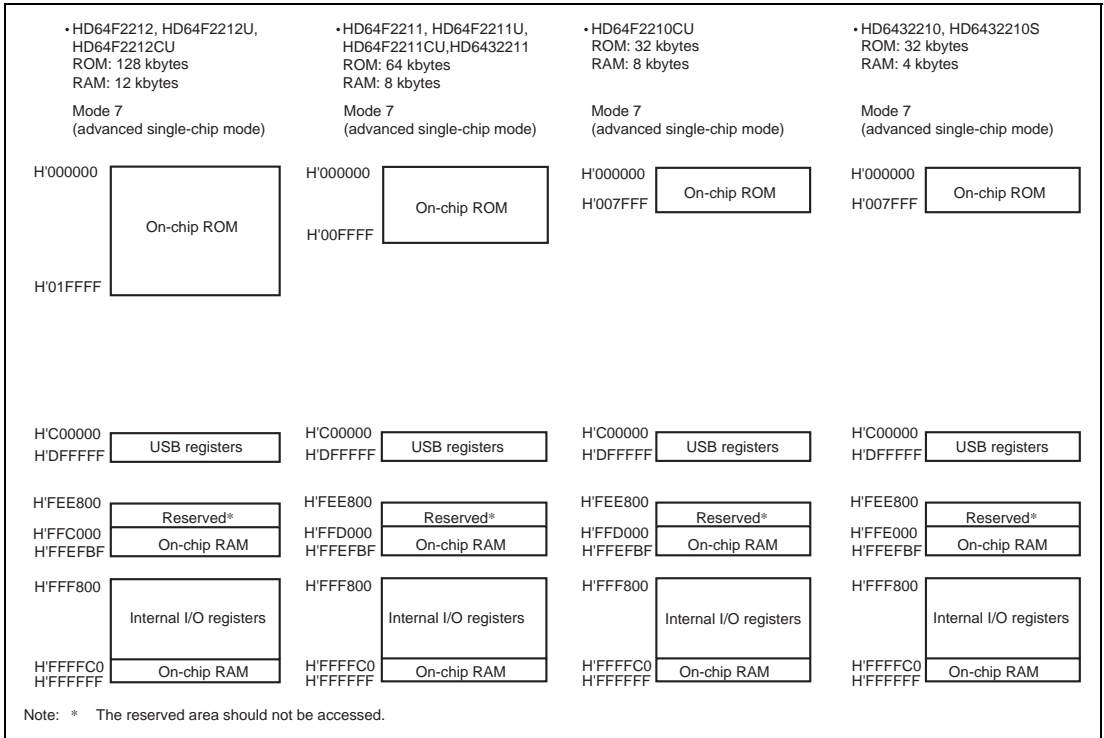


Figure 3.2 Memory Map in Each Operating Mode for HD64F2217CU



**Figure 3.3 Memory Map in Each Operating Mode for HD6432217**



**Figure 3.4 Memory Map in Each Operating Mode for HD64F2212, HD64F2212U, HD64F2212CU, HD64F2211, HD64F2211U, HD64F2211CU, HD64F2210CU, HD6432211, HD6432210 and HD6432210S**



## Section 4 Exception Handling

### 4.1 Exception Handling Types and Priority

As table 4.1 indicates, exception handling may be caused by a reset, trace, trap instruction, or interrupt. Exception handling is prioritized as shown in table 4.1. If two or more exceptions occur simultaneously, they are accepted and processed in order of priority. Exception sources, the stack structure, and operation of the CPU vary depending on the interrupt control mode. For details on the interrupt control mode, refer to section 5, Interrupt Controller.

**Table 4.1 Exception Types and Priority**

Priority	Exception Type	Start of Exception Handling
High ↑	Reset	Starts immediately after a low-to-high transition at the $\overline{\text{RES}}$ or $\overline{\text{MRES}}$ * pin, or when the watchdog timer overflows. The CPU enters the reset state when the $\overline{\text{RES}}$ pin is low. The CPU enters the manual reset state when the $\overline{\text{MRES}}$ pin* is low.
	Trace	Starts when execution of the current instruction or exception handling ends, if the trace (T) bit in the EXR is set to 1. This is enabled only in trace interrupt control mode 2. Trace exception processing is not performed after RTE instruction execution.
	Interrupt	Starts when execution of the current instruction or exception handling ends, if an interrupt request has been issued. Note that after executing the ANDC, ORC, XORC, or LDC instruction or at the completion of reset exception processing, no interrupt is detected.
Low	Trap instruction (TRAPA)	Started by execution of a trap instruction (TRAPA). Trap exception processing is always accepted in program execution state.

Note: \* Supported only by the H8S/2218 Group.

### 4.2 Exception Sources and Exception Vector Table

Different vector addresses are assigned to different exception sources. Table 4.2 lists the exception sources and their vector addresses. Since the usable modes differ depending on the product, for details on each product, refer to section 3, MCU Operating Modes.

Table 4.2 Exception Handling Vector Table

Exception Source	Vector Number	Vector Address* <sup>1</sup>		
		Normal Mode* <sup>4</sup>	Advanced Mode	
Power-on reset	0	H'0000 to H'0001	H'0000 to H'0003	
Manual reset	1	H'0002 to H'0003	H'0004 to H'0007	
Reserved for system use	2	H'0004 to H'0005	H'0008 to H'000B	
	3	H'0006 to H'0007	H'000C to H'000F	
	4	H'0008 to H'0019	H'0010 to H'0013	
Trace	5	H'000A to H'000B	H'0014 to H'0017	
Direct transitions* <sup>2</sup>	6	H'000C to H'000D	H'0018 to H'001B	
External interrupt (NMI)	7	H'000E to H'000F	H'001C to H'001F	
Trap instruction	#0	8	H'0010 to H'0011	H'0020 to H'0023
	#1	9	H'0012 to H'0013	H'0024 to H'0027
	#2	10	H'0014 to H'0015	H'0028 to H'002B
	#3	11	H'0016 to H'0017	H'002C to H'002F
Reserved for system use	12	H'0018 to H'0019	H'0030 to H'0033	
	13	H'001A to H'001B	H'0034 to H'0037	
	14	H'001C to H'001D	H'0038 to H'003B	
	15	H'001E to H'001F	H'003C to H'003F	
External interrupt	IRQ0	16	H'0020 to H'0021	H'0040 to H'0043
External interrupt	IRQ1	17	H'0022 to H'0023	H'0044 to H'0047
External interrupt	IRQ2	18	H'0024 to H'0025	H'0048 to H'004B
External interrupt	IRQ3	19	H'0026 to H'0027	H'004C to H'004F
External interrupt	IRQ4	20	H'0028 to H'0029	H'0050 to H'0053
RTC interrupt	IRQ5	21	H'002A to H'002B	H'0054 to H'0057
USB interrupt	IRQ6	22	H'002C to H'002D	H'0058 to H'005B
External interrupt	IRQ7	23	H'002E to H'002F	H'005C to H'005F
Internal interrupt* <sup>3</sup>	24	H'0030 to H'0031	H'0060 to H'0063	
	127	H'00FE to H'00FF	H'01FC to H'01FF	

Notes: 1. Lower 16 bits of the address.

2. For direct transfer, see section 20.10, Direct Transitions.

3. For details of internal interrupt vectors, see section 5.5, Interrupt Exception Handling Vector Table.

4. Not available in this LSI.

## 4.3 Reset

A reset has the highest exception priority.

When the  $\overline{\text{RES}}$  or  $\overline{\text{MRES}}^*$  pin goes low, all processing halts and this LSI enters the reset state. To ensure that this LSI is reset, hold the  $\overline{\text{RES}}$  pin low for at least 20 ms at power-up or hold the  $\overline{\text{RES}}$  or  $\overline{\text{MRES}}^*$  pin low for at least 20 states during operation.

A reset initializes the internal state of the CPU and the registers of on-chip peripheral modules.

This LSI can also be reset by overflow of the watchdog timer. For details, see section 10, Watchdog Timer (WDT).

Immediately after a reset, interrupt control mode 0 is set.

Notes:  $\overline{\text{TRST}}$  in the HD64F2218, HD64F2218U, HD64F2218CU and HD64F2217CU, which incorporate a boundary scan function, should be brought low when power is on. For details, see section 13, Boundary Scan Function.

\* Supported only by the H8S/2218 Group.

### 4.3.1 Reset Types

A reset can be of either of two types for the H8S/2218 Group: a power-on reset or a manual reset. A reset for the H8S/2212 Group is power-on reset. Reset types are shown in table 4.3. A power-on reset should be used when powering on.

The internal state of the CPU is initialized by either type of reset. A power-on reset also initializes all the registers in the on-chip peripheral modules, while a manual reset initializes all the registers in the on-chip peripheral modules except for the bus controller and I/O ports, which retain their previous states.

With a manual reset, since the on-chip peripheral modules are initialized, ports used as on-chip peripheral module I/O pins are switched to I/O ports controlled by DDR and DR.

**Table 4.3 Reset Types**

Type	Reset Transition Condition		Internal State	
	$\overline{\text{MRES}}$	$\overline{\text{RES}}$	CPU	On-Chip Peripheral Modules
Power-on reset	x	Low	Initialized	Initialized
Manual reset	Low	High	Initialized	Initialized, except for bus controller and I/O ports

Legend:

x: Don't care

A reset caused by the watchdog timer can also be of either of two types: a power-on reset or a manual reset.

When the  $\overline{\text{MRES}}$  pin\* is used,  $\overline{\text{MRES}}$  pin\* input must be enabled by setting the MRESE bit to 1 in SYSCR.

Note:\* Supported only by the H8S/2218 Group.

#### 4.3.2 Reset Exception Handling

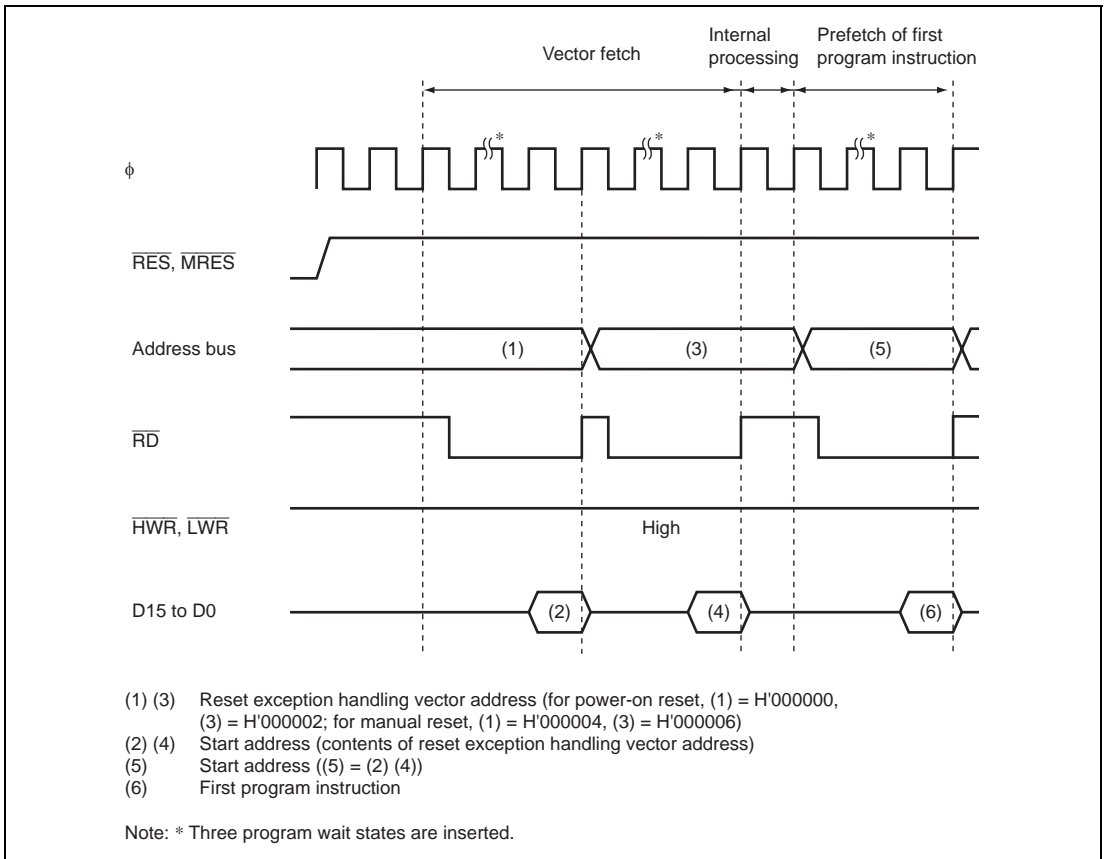
When the  $\overline{\text{RES}}$  or  $\overline{\text{MRES}}$ \* pin goes low, this LSI enters the reset. To ensure that this LSI is reset, hold the  $\overline{\text{RES}}$  pin low for at least 20 ms at power-up. To reset the chip during operation, hold the  $\overline{\text{RES}}$  or  $\overline{\text{MRES}}$ \* pin low for at least 20 states.

When the  $\overline{\text{RES}}$  or  $\overline{\text{MRES}}$ \* pin goes high after being held low for the necessary time, this LSI starts reset exception handling as follows.

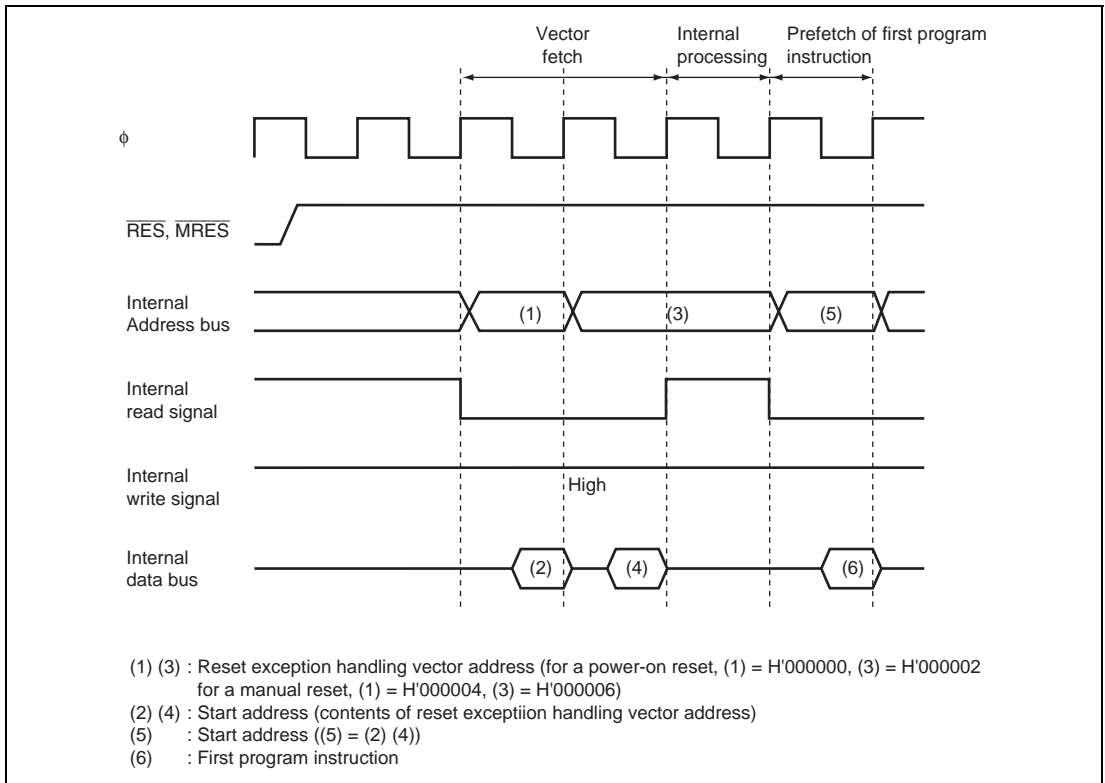
1. The internal state of the CPU and the registers of the on-chip peripheral modules are initialized, the T bit is cleared to 0 in EXR, and the I bit is set to 1 in EXR and CCR.
2. The reset exception handling vector address is read and transferred to the PC, and program execution starts from the address indicated by the PC.

Note: \*Supported only by the H8S/2218 Group.

Figures 4.1 and 4.2 show examples of the reset sequence.



**Figure 4.1 Reset Sequence (Mode 4)**



**Figure 4.2 Reset Sequence (Modes 6 and 7)**

### 4.3.3 Interrupts after Reset

If an interrupt is accepted after a reset but before the stack pointer (SP) is initialized, the PC and CCR will not be saved correctly, leading to a program crash. To prevent this, all interrupt requests, including NMI, are disabled immediately after a reset. Since the first instruction of a program is always executed immediately after the reset state ends, make sure that this instruction initializes the stack pointer (example: `MOV.L #xx: 32,SP`).

### 4.3.4 State of On-Chip Peripheral Modules after Reset Release

After reset release, MSTPCRA, MSTPCRB, and MSTPCRC are initialized and all modules except the DMAC enter module stop mode. Consequently, on-chip peripheral module registers cannot be read from or written to. Register reading and writing is enabled when module stop mode is exited.

## 4.4 Traces

Traces are enabled in interrupt control mode 2. Trace mode is not activated in interrupt control mode 0, irrespective of the state of the T bit. For details of interrupt control modes, see section 5, Interrupt Controller.

If the T bit in EXR is set to 1, trace mode is activated. In trace mode, a trace exception occurs on completion of each instruction. Trace mode is not affected by interrupt masking. Table 4.4 shows the state of CCR and EXR after execution of trace exception handling. Trace mode is canceled by clearing the T bit in EXR to 0. The T bit saved on the stack retains its value of 1, and when control is returned from the trace exception handling routine by the RTE instruction, trace mode resumes.

Trace exception handling is not carried out after execution of the RTE instruction.

Interrupts are accepted even within the trace exception handling routine.

**Table 4.4 Status of CCR and EXR after Trace Exception Handling**

Interrupt Control Mode	CCR			EXR
	I	UI	I2 to I0	T
0	Trace exception handling cannot be used.			
2	1	–	–	0

Legend:

1: Set to 1

0: Cleared to 0

–: Retains value prior to execution.

## 4.5 Interrupts

Interrupts are controlled by the interrupt controller. The interrupt controller has two interrupt control modes and can assign interrupts other than NMI to eight priority/mask levels to enable multiplexed interrupt control. The source to start interrupt exception handling and the vector address differ depending on the product. For details, refer to section 5, Interrupt Controller.

The interrupt exception handling is as follows:

1. The values in the program counter (PC), condition code register (CCR), and extended control register (EXR) are saved in the stack.
2. The interrupt mask bit is updated and the T bit is cleared.
3. A vector address corresponding to the interrupt source is generated, the start address is loaded from the vector table to the PC, and program execution starts from that address.

## 4.6 Trap Instruction

Trap instruction exception handling starts when a TRAPA instruction is executed. Trap instruction exception handling can be executed at all times in the program execution state.

The trap instruction exception handling is as follows:

1. The values in the program counter (PC), condition code register (CCR), and extended control register (EXR) are saved in the stack.
2. The interrupt mask bit is updated and the T bit is cleared.
3. A vector address corresponding to the interrupt source is generated, the start address is loaded from the vector table to the PC, and program execution starts from that address.

The TRAPA instruction fetches a start address from a vector table entry corresponding to a vector number from 0 to 3, as specified in the instruction code.

Table 4.5 shows the status of CCR and EXR after execution of trap instruction exception handling.

**Table 4.5 Status of CCR and EXR after Trap Instruction Exception Handling**

Interrupt Control Mode	CCR			EXR
	I	UI	I2 to I0	T
0	1	–	–	–
2	1	–	–	0

Legend:

1: Set to 1

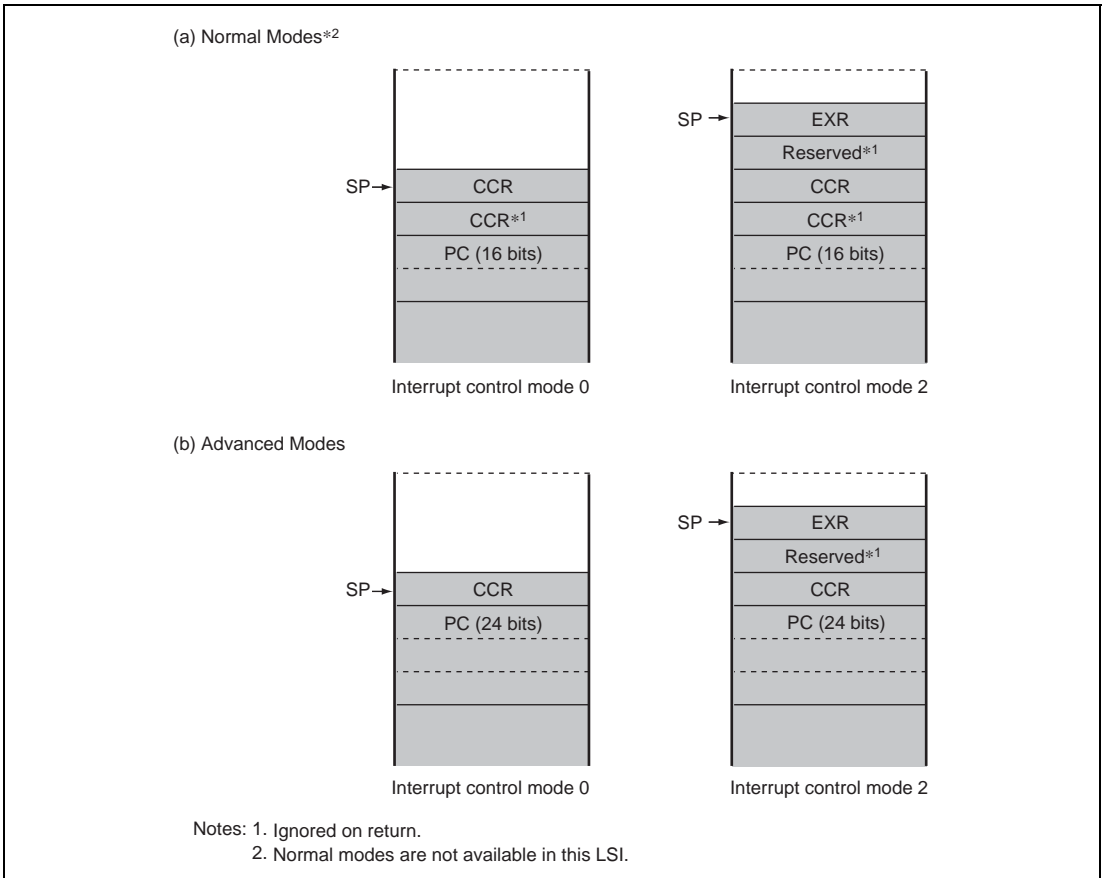
0: Cleared to 0

–: Retains value prior to execution.



## 4.7 Stack Status after Exception Handling

Figure 4.3 shows the stack after completion of trap instruction exception handling and interrupt exception handling.



**Figure 4.3 Stack Status after Exception Handling**

## 4.8 Notes on Use of the Stack

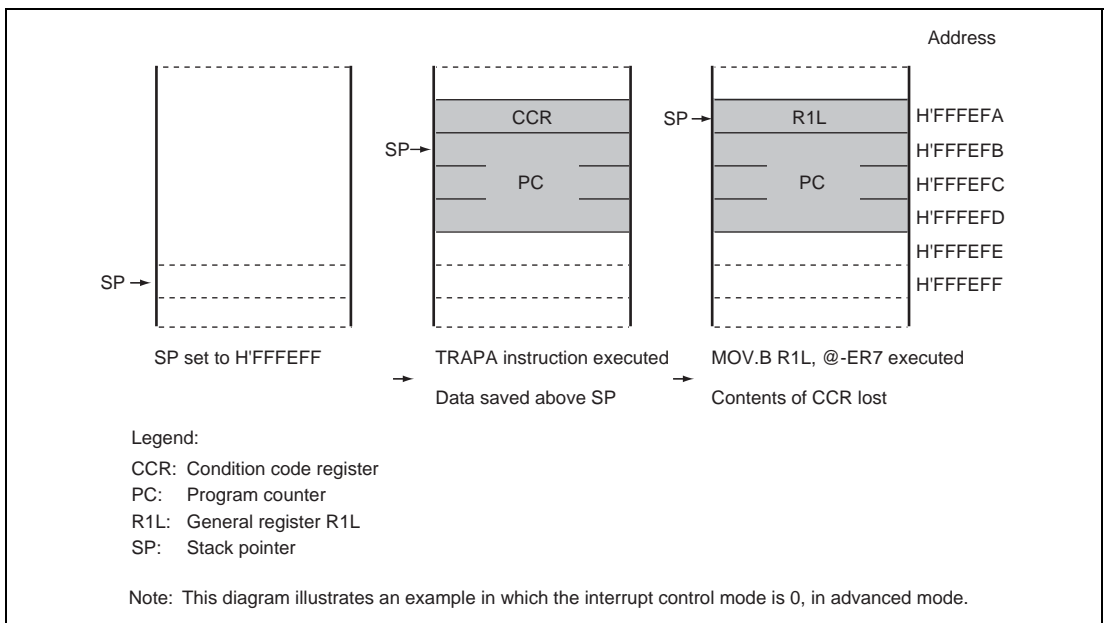
When accessing word data or longword data, this LSI assumes that the lowest address bit is 0. The stack should always be accessed by word transfer instruction or longword transfer instruction, and the value of the stack pointer (SP: ER7) should always be kept even. Use the following instructions to save registers:

```
PUSH.W Rn (or MOV.W Rn, @-SP)
PUSH.L ERn (or MOV.L ERn, @-SP)
```

Use the following instructions to restore registers:

```
POP.W Rn (or MOV.W @SP+, Rn)
POP.L ERn (or MOV.L @SP+, ERn)
```

Setting SP to an odd value may lead to a malfunction. Figure 4.4 shows an example of what happens when the SP value is odd.



**Figure 4.4 Operation when SP Value Is Odd**

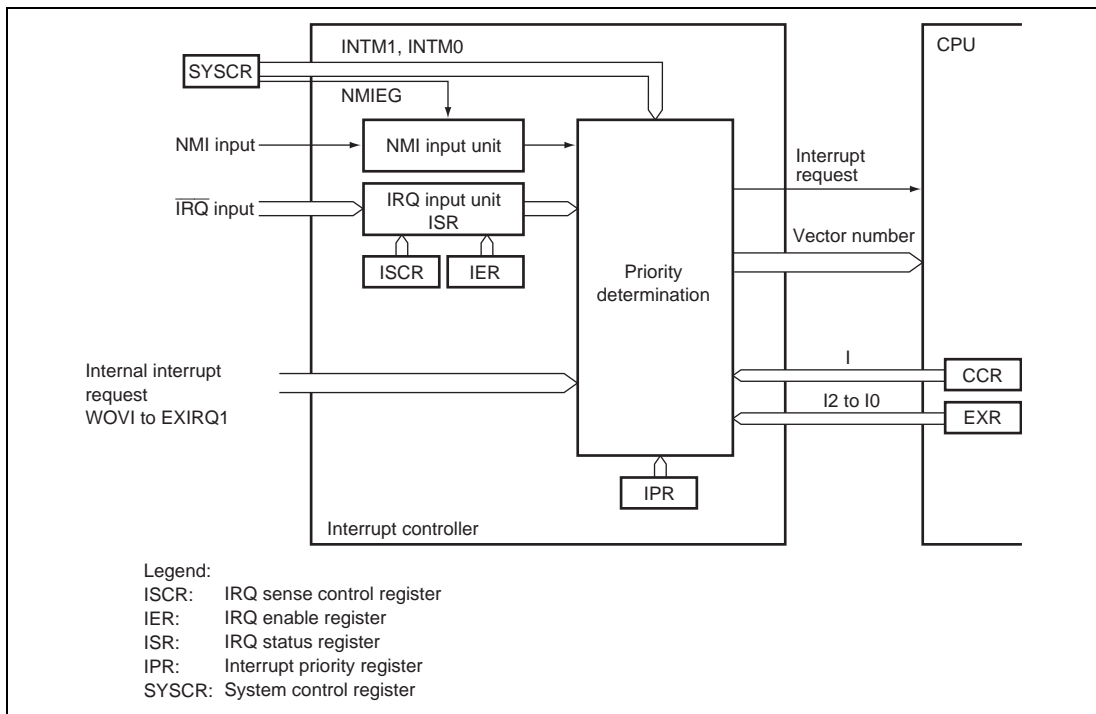
---

## Section 5 Interrupt Controller

### 5.1 Features

- Two interrupt control modes
  - Any of two interrupt control modes can be set by means of the INTM1 and INTM0 bits in the system control register (SYSCR).
- Priorities settable with IPR
  - An interrupt priority register (IPR) is provided for setting interrupt priorities. Eight priority levels can be set for each module for all interrupts except NMI. NMI is assigned the highest priority level of 8, and can be accepted at all times.
- Independent vector addresses
  - All interrupt sources are assigned independent vector addresses, making it unnecessary for the source to be identified in the interrupt handling routine.
- Seven external interrupts (NMI,  $\overline{\text{IRQ}}7$ , and  $\overline{\text{IRQ}}4$  to  $\overline{\text{IRQ}}0$ )
  - NMI is the highest-priority interrupt, and is accepted at all times. Rising edge or falling edge can be selected for NMI. Falling edge, rising edge, or both edge detection, or level sensing, can be selected for  $\overline{\text{IRQ}}7$  and  $\overline{\text{IRQ}}4$  to  $\overline{\text{IRQ}}0$ .  $\overline{\text{IRQ}}6$  is an interrupt only for the on-chip USB.  $\overline{\text{IRQ}}5$  is an interrupt only for the on-chip RTC.
- DMAC control
  - DMAC activation is performed by means of interrupts.

A block diagram of the interrupt controller is shown in figure 5.1.



**Figure 5.1 Block Diagram of Interrupt Controller**

## 5.2 Input/Output Pins

Table 5.1 summarizes the pins of the interrupt controller.

**Table 5.1 Pin Configuration**

Name	I/O	Function
NMI	Input	Nonmaskable external interrupt Rising or falling edge can be selected
$\overline{\text{IRQ7}}$	Input	Maskable external interrupts
$\overline{\text{IRQ4}}$	Input	Rising, falling, or both edges, or level sensing can be selected ( $\overline{\text{IRQ6}}$ is an interrupt signal only for the on-chip USB. $\overline{\text{IRQ5}}$ is an interrupt signal only for the on-chip RTC.)
$\overline{\text{IRQ3}}$	Input	
$\overline{\text{IRQ2}}$	Input	
$\overline{\text{IRQ1}}$	Input	
$\overline{\text{IRQ0}}$	Input	

## 5.3 Register Descriptions

The interrupt controller has the following registers. For details on the system control register, refer to section 3.2.2, System Control Register (SYSCR).

- System control register (SYSCR)
- IRQ sense control register H (ISCRH)
- IRQ sense control register L (ISCRL)
- IRQ enable register (IER)
- IRQ status register (ISR)
- Interrupt priority register A (IPRA)
- Interrupt priority register B (IPRB)
- Interrupt priority register C (IPRC)
- Interrupt priority register D (IPRD)
- Interrupt priority register E (IPRE)
- Interrupt priority register F (IPRF)
- Interrupt priority register G (IPRG)
- Interrupt priority register J (IPRJ)
- Interrupt priority register K (IPRK)
- Interrupt priority register M (IPRM)

### 5.3.1 Interrupt Priority Registers A to G, J, K, M (IPRA to IPRG, IPRJ, IPRK, IPRM)

The IPR registers set priorities (levels 7 to 0) for interrupts other than NMI.

The correspondence between interrupt sources and IPR settings is shown in section 5.5, Interrupt Exception Handling Vector Table. Setting a value in the range from H'0 to H'7 in the 3-bit groups of bits 6 to 4 and 2 to 0 sets the priority of the corresponding interrupt.

Bit	Bit Name	Initial Value	R/W	Description
7	–	0	–	Reserved This bit is always read as 0 and cannot be modified.
6	IPR6	1	R/W	These bits set the priority of the corresponding interrupt source.
5	IPR5	1	R/W	
4	IPR4	1	R/W	
				000: Priority level 0 (Lowest) 001: Priority level 1 010: Priority level 2 011: Priority level 3 100: Priority level 4 101: Priority level 5 110: Priority level 6 111: Priority level 7 (Highest)
3	–	0	–	Reserved This bit is always read as 0 and cannot be modified.
2	IPR2	1	R/W	These bits set the priority of the corresponding interrupt source.
1	IPR1	1	R/W	
0	IPR0	1	R/W	
				000: Priority level 0 (Lowest) 001: Priority level 1 010: Priority level 2 011: Priority level 3 100: Priority level 4 101: Priority level 5 110: Priority level 6 111: Priority level 7 (Highest)

### 5.3.2 IRQ Enable Register (IER)

IER controls enabling and disabling of interrupt requests IRQ7 to IRQ0.

Bit	Bit Name	Initial Value	R/W	Description
7	IRQ7E	0	R/W	IRQ7 Enable The IRQ7 interrupt request is enabled when this bit is 1.
6	IRQ6E	0	R/W	IRQ6 Enable* <sup>1</sup> The IRQ6 interrupt request is enabled when this bit is 1.
5	IRQ5E	0	R/W	IRQ5 Enable* <sup>2</sup> The IRQ5 interrupt request is enabled when this bit is 1.
4	IRQ4E	0	R/W	IRQ4 Enable The IRQ4 interrupt request is enabled when this bit is 1.
3	IRQ3E	0	R/W	IRQ3 Enable The IRQ3 interrupt request is enabled when this bit is 1.
2	IRQ2E	0	R/W	IRQ2 Enable The IRQ2 interrupt request is enabled when this bit is 1.
1	IRQ1E	0	R/W	IRQ1 Enable The IRQ1 interrupt request is enabled when this bit is 1.
0	IRQ0E	0	R/W	IRQ0 Enable The IRQ0 interrupt request is enabled when this bit is 1.

Notes: 1. IRQ6 is an interrupt only for the on-chip USB.  
2. IRQ5 is an interrupt only for the on-chip RTC.

### 5.3.3 IRQ Sense Control Registers H and L (ISCRH, ISCLR)

The ISCR registers select the source that generates an interrupt request at pins  $\overline{\text{IRQ7}}$  to  $\overline{\text{IRQ0}}$ .

Bit	Bit Name	Initial Value	R/W	Description
15	IRQ7SCB	0	R/W	IRQ7 Sense Control B
14	IRQ7SCA	0	R/W	IRQ7 Sense Control A 00: Interrupt request generated at $\overline{\text{IRQ7}}$ input low level 01: Interrupt request generated at falling edge of $\overline{\text{IRQ7}}$ input 10: Interrupt request generated rising edge of $\overline{\text{IRQ7}}$ input 11: Interrupt request generated at both falling and rising edges of $\overline{\text{IRQ7}}$ input
13	IRQ6SCB	0	R/W	IRQ6* <sup>1</sup> Sense Control B
12	IRQ6SCA	0	R/W	IRQ6* <sup>1</sup> Sense Control A 00: Setting prohibited when using on-chip USB suspend or resume interrupt 01: Interrupt request generated at falling edge of $\overline{\text{IRQ6}}$ input 1x: Setting prohibited
11	IRQ5SCB	0	R/W	IRQ5* <sup>2</sup> Sense Control B
10	IRQ5SCA	0	R/W	IRQ5* <sup>2</sup> Sense Control A 00: Setting prohibited when using RTC interrupt 01: Interrupt request generated at falling edge of $\overline{\text{IRQ5}}$ input 1x: Setting prohibited
9	IRQ4SCB	0	R/W	IRQ4 Sense Control B
8	IRQ4SCA	0	R/W	IRQ4 Sense Control A 00: Interrupt request generated at $\overline{\text{IRQ4}}$ input low level 01: Interrupt request generated at falling edge of $\overline{\text{IRQ4}}$ input 10: Interrupt request generated at rising edge of $\overline{\text{IRQ4}}$ input 11: Interrupt request generated at both falling and rising edges of $\overline{\text{IRQ4}}$ input



Bit	Bit Name	Initial Value	R/W	Description
7	IRQ3SCB	0	R/W	IRQ3 Sense Control B
6	IRQ3SCA	0	R/W	IRQ3 Sense Control A 00: Interrupt request generated at $\overline{\text{IRQ3}}$ input low level 01: Interrupt request generated at falling edge of $\overline{\text{IRQ3}}$ input 10: Interrupt request generated at rising edge of $\overline{\text{IRQ3}}$ input 11: Interrupt request generated at both falling and rising edges of $\overline{\text{IRQ3}}$ input
5	IRQ2SCB	0	R/W	IRQ2 Sense Control B
4	IRQ2SCA	0	R/W	IRQ2 Sense Control A 00: Interrupt request generated at $\overline{\text{IRQ2}}$ input low level 01: Interrupt request generated at falling edge of $\overline{\text{IRQ2}}$ input 10: Interrupt request generated at rising edge of $\overline{\text{IRQ2}}$ input 11: Interrupt request generated at both falling and rising edges of $\overline{\text{IRQ2}}$ input
3	IRQ1SCB	0	R/W	IRQ1 Sense Control B
2	IRQ1SCA	0	R/W	IRQ1 Sense Control A 00: Interrupt request generated at $\overline{\text{IRQ1}}$ input low level 01: Interrupt request generated at falling edge of $\overline{\text{IRQ1}}$ input 10: Interrupt request generated at rising edge of $\overline{\text{IRQ1}}$ input 11: Interrupt request generated at both falling and rising edges of $\overline{\text{IRQ1}}$ input

Bit	Bit Name	Initial Value	R/W	Description
1	IRQ0SCB	0	R/W	IRQ0 Sense Control B
0	IRQ0SCA	0	R/W	IRQ0 Sense Control A
				00: Interrupt request generated at $\overline{\text{IRQ0}}$ input low level
				01: Interrupt request generated at falling edge of $\overline{\text{IRQ0}}$ input
				10: Interrupt request generated at rising edge of $\overline{\text{IRQ0}}$ input
				11: Interrupt request generated at both falling and rising edges of $\overline{\text{IRQ0}}$ input

Legend:

x: Don't care

Notes: 1. IRQ6 is an interrupt only for the on-chip USB.  
2. IRQ5 is an interrupt only for the on-chip RTC.

### 5.3.4 IRQ Status Register (ISR)

ISR indicates the status of IRQ7 to IRQ0 interrupt requests.

Bit	Bit Name	Initial Value	R/W	Description
7	IRQ7F	0	R/(W)*	[Setting condition]
6	IRQ6F	0	R/(W)*	When the interrupt source selected by the ISCR registers occurs
5	IRQ5F	0	R/(W)*	[Clearing conditions]
4	IRQ4F	0	R/(W)*	<ul style="list-style-type: none"> <li>Cleared by reading IRQnF flag when IRQnF = 1, then writing 0 to IRQnF flag</li> </ul>
3	IRQ3F	0	R/(W)*	
2	IRQ2F	0	R/(W)*	<ul style="list-style-type: none"> <li>When interrupt exception handling is executed when low-level detection is set and , <math>\overline{\text{IRQn}}</math> input is high</li> </ul>
1	IRQ1F	0	R/(W)*	
0	IRQ0F	0	R/(W)*	<ul style="list-style-type: none"> <li>When IRQn interrupt exception handling is executed when falling, rising, or both-edge detection is set</li> </ul>

Note: \* Only 0 can be written, to clear flags.

## 5.4 Interrupt Sources

### 5.4.1 External Interrupts

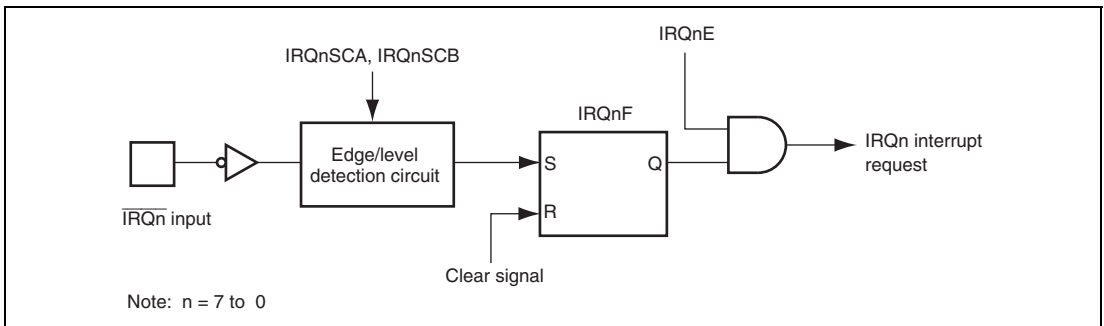
There are seven external interrupts: NMI, IRQ7, and IRQ4 to IRQ0. These interrupts can be used to restore this LSI from software standby mode. Though IRQ5 is only for the on-chip RTC and IRQ6 is only for the on-chip USB, the interrupts can be used to restore this LSI from software standby mode. IRQ5 and IRQ6 are functionally same as IRQ7 and IRQ4 to IRQ0.

**NMI Interrupt:** NMI is the highest-priority interrupt, and is always accepted by the CPU regardless of the interrupt control mode or the status of the CPU interrupt mask bits. The NMIEG bit in SYSCR can be used to select whether an interrupt is requested at a rising edge or a falling edge on the NMI pin.

**IRQ7 to IRQ0 Interrupts:** Interrupts IRQ7 to IRQ0 are requested by an input signal at pins  $\overline{\text{IRQ}}_7$  to  $\overline{\text{IRQ}}_0$ . Interrupts IRQ7 to IRQ0 have the following features:

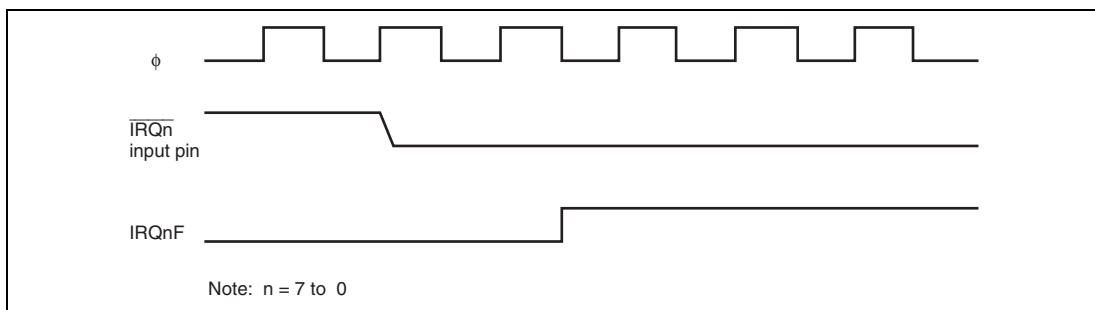
- Using ISCR, it is possible to select whether an interrupt is generated by a low level, falling edge, rising edge, or both edges, at pins  $\overline{\text{IRQ}}_7$  to  $\overline{\text{IRQ}}_0$
- Enabling or disabling of interrupt requests IRQ7 to IRQ0 can be selected with IER.
- The interrupt priority level can be set with IPR.
- The status of interrupt requests IRQ7 to IRQ0 is indicated in ISR. ISR flags can be cleared to 0 by software.

A block diagram of IRQ<sub>n</sub> interrupts is shown in figure 5.2.



**Figure 5.2 Block Diagram of Interrupts IRQ<sub>n</sub>**

The set timing for IRQnF is shown in figure 5.3.



**Figure 5.3 Timing of Setting IRQnF**

The detection of IRQn interrupts does not depend on whether the relevant pin has been set for input or output. However, when a pin is used as an external interrupt input pin, do not clear the corresponding DDR to 0; and use the pin as an I/O pin for another function. IRQnF interrupt request flag is set when the setting condition is satisfied, regardless of IER settings. Accordingly, refer to only necessary flags.

## 5.4.2 Internal Interrupts

The sources for internal interrupts from on—chip peripheral modules have the following features:

- For each on—chip peripheral module there are flags that indicate the interrupt request status, and enable bits that select enabling or disabling of these interrupts. If both of these are set to 1 for a particular interrupt source, an interrupt request is issued to the interrupt controller.
- The interrupt priority level can be set by means of IPR.
- The DMAC can be activated by a TPU, SCI, or other interrupt request.
- When the DMAC is activated by an interrupt request, it is not affected by the interrupt control mode or CPU interrupt mask bit.

## 5.5 Interrupt Exception Handling Vector Table

Table 5.2 shows interrupt exception handling sources, vector addresses, and interrupt priorities.

For default priorities, the lower the vector number, the higher the priority. Priorities among modules can be set by means of the IPR. Modules set at the same priority will conform to their default priorities. Priorities within a module are fixed.

**Table 5.2 Interrupt Sources, Vector Addresses, and Interrupt Priorities**

Interrupt Source	Origin of Interrupt Source	Vector Number	Vector Address*		Priority
			Advanced Mode	IPR	
External pins	NMI	7	H'001C		High ↑
	IRQ0	16	H'0040	IPRA6 to IPRA4	
	IRQ1	17	H'0044	IPRA2 to IPRA0	
	IRQ2	18	H'0048	IPRB6 to IPRB4	
	IRQ3	19	H'004C		
	IRQ4	20	H'0050	IPRB2 to IPRB0	
RTC	IRQ5	21	H'0054		
USB	IRQ6	22	H'0058	IPRC6 to IPRC4	
External pins	IRQ7	23	H'005C		
Watchdog Timer	WOVI	25	H'0064	IPRD6 to IPRD4	
A/D	ADI	28	H'0070	IPRE2 to IPRE0	
TPU channel 0	TGI0A	32	H'0080	IPRF6 to IPRF4	
	TGI0B	33	H'0084		
	TGI0C	34	H'0088		
	TGI0D	35	H'008C		
	TGI0V	36	H'0090		
TPU channel 1	TGI1A	40	H'00A0	IPRF2 to IPRF0	
	TGI1B	41	H'00A4		
	TGI1V	42	H'00A8		
	TGI1U	43	H'00AC		Low

Interrupt Source	Origin of Interrupt Source	Vector Number	Vector Address*		Priority
			Advanced Mode	IPR	
TPU channel 2	TGI2A	44	H'00B0	IPRG6 to IPRG4	High ↑
	TGI2B	45	H'00B4		
	TGI2V	46	H'00B8		
	TGI2U	47	H'00BC		
DMAC	DEND0A	72	H'0120	IPRJ6 to IPRJ4	
	DEND0B	73	H'0124		
	DEND1A	74	H'0128		
	DEND1B	75	H'012C		
SCI channel 0	ERI0	80	H'0140	IPRJ2 to IPRJ0	
	RXI0	81	H'0144		
	TXI0	82	H'0148		
	TEI0	83	H'014C		
SCI channel 2	ERI2	88	H'0160	IPRK2 to IPRK0	
	RXI2	89	H'0164		
	TXI2	90	H'0168		
	TEI2	91	H'016C		
USB	EXIRQ0	104	H'01A0	IPRM6 to IPRM4	Low
	EXIRQ1	105	H'01A4		

Note: \* Lower 16 bits of the start address.

## 5.6 Interrupt Control Modes and Interrupt Operation

The interrupt controller has two modes: interrupt control mode 0 and interrupt control mode 2.

Interrupt operations differ depending on the interrupt control mode. The interrupt control mode is selected by SYSCR. Table 5.3 shows the differences between interrupt control mode 0 and interrupt control mode 2.

**Table 5.3 Interrupt Control Modes**

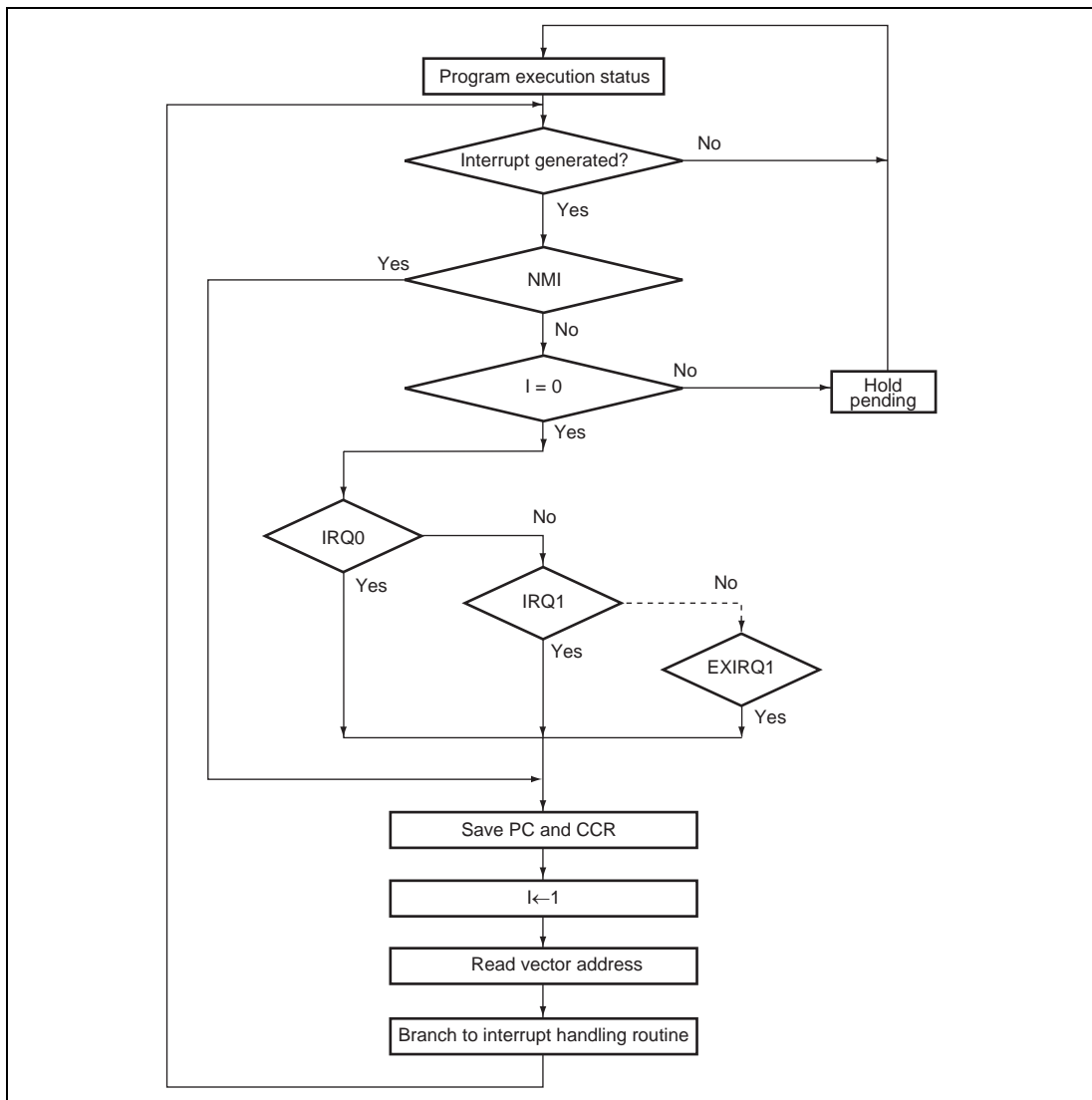
Interrupt Control Mode	Priority Setting Register	Interrupt Mask Bits	Description
0	Default	I	The priority of interrupt sources are fixed at the default settings. Interrupt sources except for NMI is masked by the I bit.
2	IPR	I2 to I0	8-level interrupt mask control is performed by bits I2 to I0. 8 priority levels other than NMI can be set with IPR.

### 5.6.1 Interrupt Control Mode 0

In interrupt control mode 0, interrupt requests except for NMI is masked by the I bit of CCR in the CPU. Figure 5.4 shows a flowchart of the interrupt acceptance operation in this case.

1. If an interrupt source occurs when the corresponding interrupt enable bit is set to 1, an interrupt request is sent to the interrupt controller.
2. If the I bit is set to 1, only an NMI interrupt is accepted, and other interrupt requests are held pending. If the I bit is cleared, an interrupt request is accepted.
3. Interrupt requests are sent to the interrupt controller, the highest-ranked interrupt according to the priority system is accepted, and other interrupt requests are held pending.
4. When the CPU accepts an interrupt request, it starts interrupt exception handling after execution of the current instruction has been completed.
5. The PC and CCR are saved to the stack area by interrupt exception handling. The PC saved on the stack shows the address of the first instruction to be executed after returning from the interrupt handling routine.
6. Next, the I bit in CCR is set to 1. This masks all interrupts except NMI.

7. The CPU generates a vector address for the accepted interrupt and starts execution of the interrupt handling routine at the address indicated by the contents of the vector address in the vector table.



**Figure 5.4 Flowchart of Procedure Up to Interrupt Acceptance in Interrupt Control Mode 0**

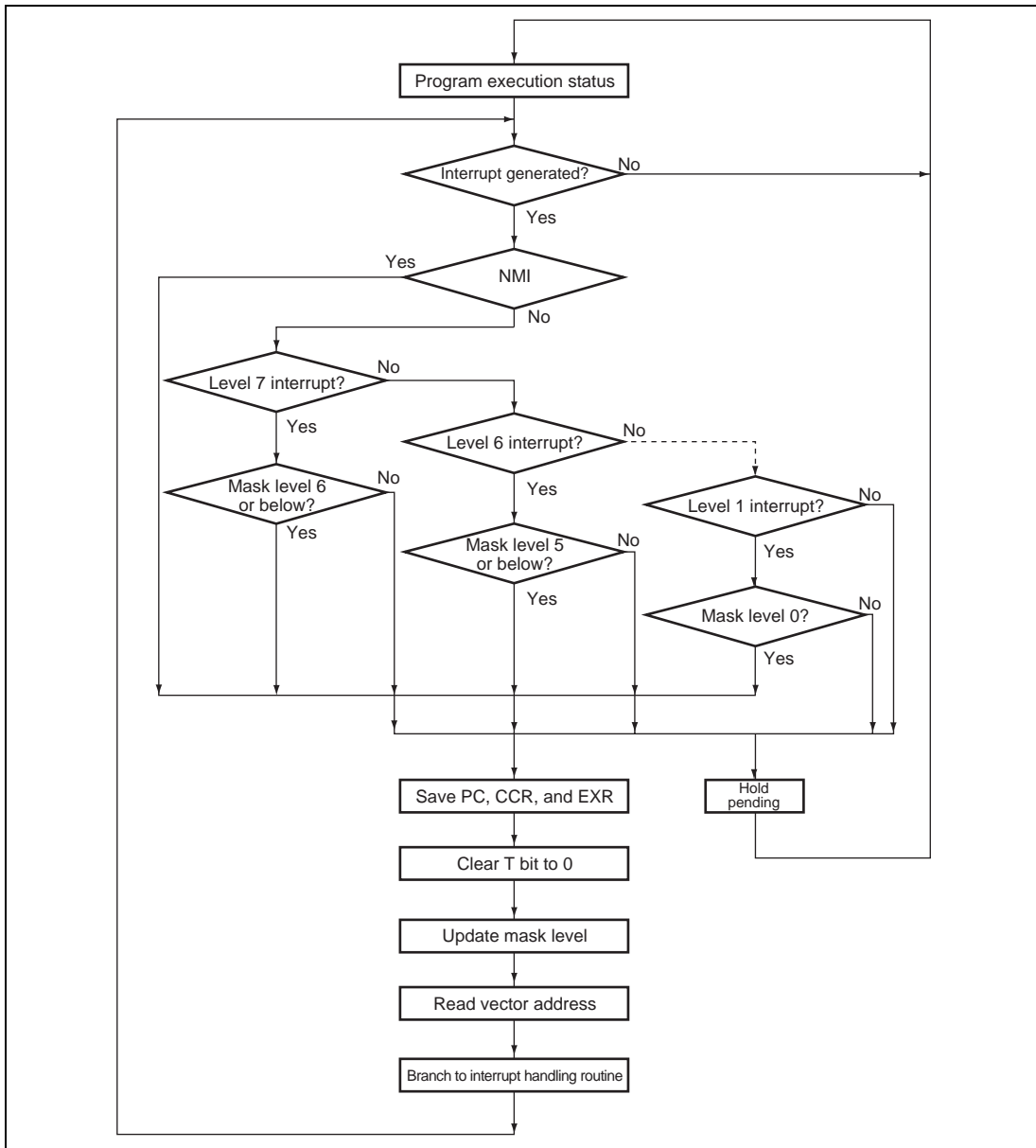


## 5.6.2 Interrupt Control Mode 2

In interrupt control mode 2, mask control is done in eight levels for interrupt requests except for NMI by comparing the EXR interrupt mask level (I2 to I0 bits) in the CPU and the IPR setting.

Figure 5.5 shows a flowchart of the interrupt acceptance operation in this case.

1. If an interrupt source occurs when the corresponding interrupt enable bit is set to 1, an interrupt request is sent to the interrupt controller.
2. When interrupt requests are sent to the interrupt controller, the interrupt with the highest priority according to the interrupt priority levels set in IPR is selected, and lower-priority interrupt requests are held pending. If a number of interrupt requests with the same priority are generated at the same time, the interrupt request with the highest priority according to the priority system shown in table 5.2 is selected.
3. Next, the priority of the selected interrupt request is compared with the interrupt mask level set in EXR. An interrupt request with a priority no higher than the mask level set at that time is held pending, and only an interrupt request with a priority higher than the interrupt mask level is accepted.
4. When the CPU accepts an interrupt request, it starts interrupt exception handling after execution of the current instruction has been completed.
5. The PC, CCR, and EXR are saved to the stack area by interrupt exception handling. The PC saved on the stack shows the address of the first instruction to be executed after returning from the interrupt handling routine.
6. The T bit in EXR is cleared to 0. The interrupt mask level is rewritten with the priority level of the accepted interrupt.  
If the accepted interrupt is NMI, the interrupt mask level is set to H'7.
7. The CPU generates a vector address for the accepted interrupt and starts execution of the interrupt handling routine at the address indicated by the contents of the vector address in the vector table.



**Figure 5.5 Flowchart of Procedure Up to Interrupt Acceptance in Interrupt Control Mode 2**

### 5.6.3 Interrupt Exception Handling Sequence

Figure 5.6 shows the interrupt exception handling sequence. The example shown is for the case where interrupt control mode 0 is set in advanced mode, and the program area and stack area are in on-chip memory.

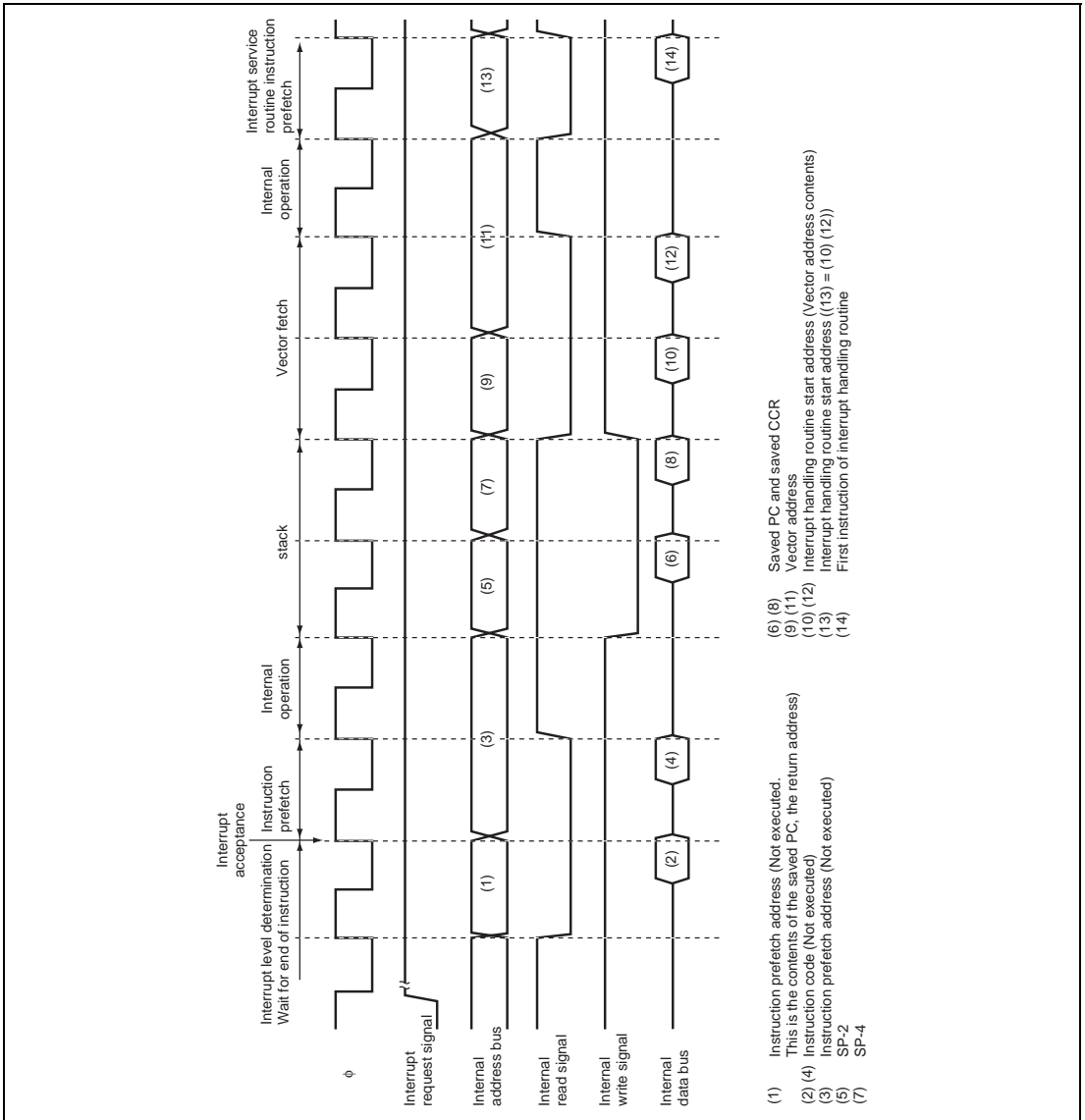


Figure 5.6 Interrupt Exception Handling

### 5.6.4 Interrupt Response Times

Table 5.4 shows interrupt response times — the interval between generation of an interrupt request and execution of the first instruction in the interrupt handling routine. The execution status symbols used in table 5.4 are explained in table 5.5.

This LSI is capable of fast word transfer to on-chip memory, and have the program area in on-chip ROM and the stack area in on-chip RAM, enabling high-speed processing.

**Table 5.4 Interrupt Response Times**

No.	Execution State	Normal Mode* <sup>5</sup>		Advanced Mode	
		Interrupt Control Mode 0	Interrupt Control Mode 2	Interrupt Control Mode 0	Interrupt Control Mode 2
1	Interrupt priority determination* <sup>1</sup>	3	3	3	3
2	Number of wait states until executing instruction ends* <sup>2</sup>	1 to 19+2·S <sub>I</sub>	1 to 19+2·S <sub>I</sub>	1 to 19+2·S <sub>I</sub>	1 to 19+2·S <sub>I</sub>
3	PC, CCR, EXR stack save	2·S <sub>K</sub>	3·S <sub>K</sub>	2·S <sub>K</sub>	3·S <sub>K</sub>
4	Vector fetch	S <sub>I</sub>	S <sub>I</sub>	2·S <sub>I</sub>	2·S <sub>I</sub>
5	Instruction fetch* <sup>3</sup>	2·S <sub>I</sub>	2·S <sub>I</sub>	2·S <sub>I</sub>	2·S <sub>I</sub>
6	Internal processing* <sup>4</sup>	2	2	2	2
Total	(using on-chip memory)	11 to 31	12 to 32	12 to 32	13 to 33

- Notes: 1. Two states in case of internal interrupt.  
 2. Refers to MULXS and DIVXS instructions.  
 3. Prefetch after interrupt acceptance and interrupt handling routine prefetch.  
 4. Internal processing after interrupt acceptance and internal processing after vector fetch.  
 5. Not available in this LSI.

**Table 5.5 Number of States in Interrupt Handling Routine Execution Statuses**

Symbol		Object of Access				
		Internal Memory	External Device			
			8-Bit Bus		16-Bit Bus	
			2-State Access	3-State Access	2-State Access	3-State Access
Instruction fetch	$S_I$	1	4	6 + 2m	2	3 + m
Branch address read	$S_J$					
Stack manipulation	$S_K$					

Legend:

m: Number of wait states in an external device access.

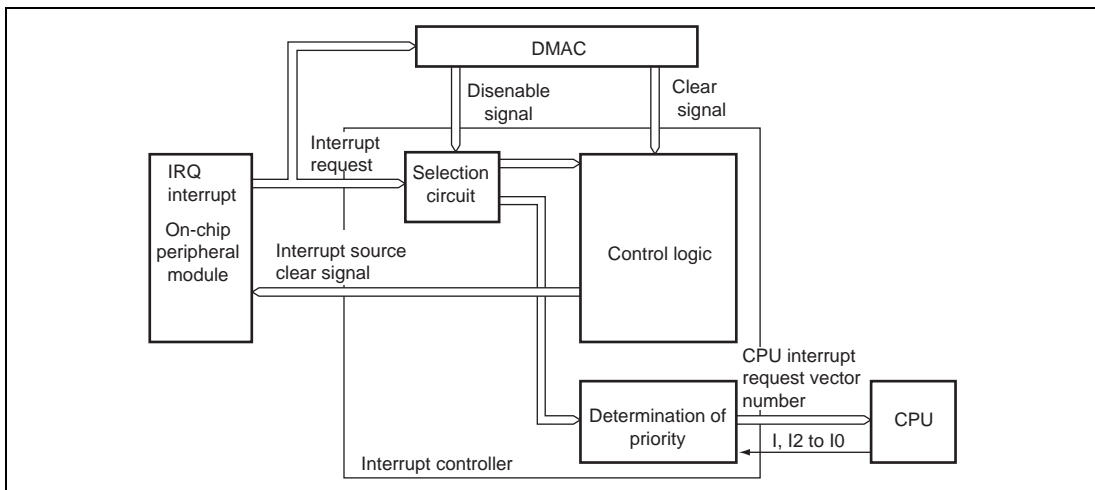
### 5.6.5 DMAC Activation by Interrupt

The DMAC can be activated by an interrupt. In this case, the following options are available:

- Interrupt request to CPU
- Activation request to DMAC
- Selection of a number of the above

For details of interrupt requests that can be used with to activate the DMAC, see section 7, DMA Controller (DMAC).

Figure 5.7 shows a block diagram of the interrupt controller of DMAC.



**Figure 5.7 Interrupt Control for DMAC**

**Selection of Interrupt Source:** An activation factor is directly input to each channel of the DMAC. The activation factors for each channel of the DMAC are selected by the DTF3 to DTF0 bits of DMACR. The DTA bit of DMABCR can be used to select whether the selected activation factors are managed by the DMAC. By setting the DTA bit to 1, the interrupt factor which was the activation factor for that DMAC cannot act as the CPU interrupt factor.

Interrupt factors other than the interrupts managed by the DMAC is CPU interrupt request.

**Determination of Priority:** The activation source is directly input to each channel of DMAC.

**Operation Order:** If the same interrupt is selected as the DMAC activation factor or CPU interrupt factor, these operate independently. They operate in accordance with the respective operating states and bus priorities.

Table 5.6 shows the interrupt factor clear control and selection of interrupt factors by specification of the DTA bit of DMAC's DMABCR.

**Table 5.6 Interrupt Source Selection and Clearing Control****Settings**

<b>DMAC</b>		<b>Interrupt Sources Selection/Clearing Control</b>	
<b>DTA</b>	<b>DMAC</b>	<b>CPU</b>	
0	Δ	O	
1	O	X	

## Legend:

- O: The relevant interrupt is used. Interrupt source clearing is performed.  
(The CPU should clear the source flag in the interrupt handling routine.)
- Δ: The relevant interrupt is used. The interrupt source is not cleared.
- X: The relevant bit cannot be used.

**Notes on Use:** The SCI interrupt source is cleared when the DMAC reads or writes to the prescribed register, and is not dependent upon the DTA bit.

## 5.7 Usage Notes

### 5.7.1 Contention between Interrupt Generation and Disabling

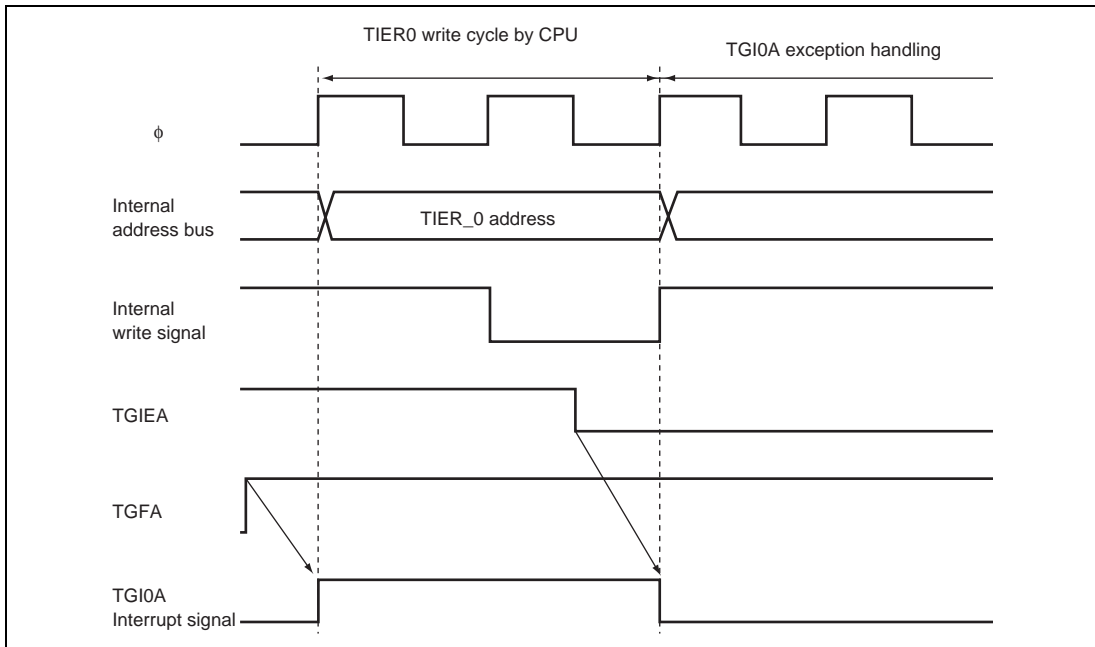
When an interrupt enable bit is cleared to 0 to disable interrupts, the disabling becomes effective after execution of the instruction.

When an interrupt enable bit is cleared to 0 by an instruction such as BCLR or MOV, if an interrupt is generated during execution of the instruction, the interrupt concerned will still be enabled on completion of the instruction, and so interrupt exception handling for that interrupt will be executed on completion of the instruction. However, if there is an interrupt request of higher priority than that interrupt, interrupt exception handling will be executed for the higher-priority interrupt, and the lower-priority interrupt will be ignored.

The same also applies when an interrupt source flag is cleared to 0.

Figure 5.8 shows an example in which the TGIEA bit in the TPU's TIER\_0 is cleared to 0.

The above contention will not occur if an enable bit or interrupt source flag is cleared to 0 while the interrupt is masked.



**Figure 5.8 Contention between Interrupt Generation and Disabling**



### 5.7.2 Instructions that Disable Interrupts

Instructions that disable interrupts are LDC, ANDC, ORC, and XORC. After any of these instructions is executed, all interrupts including NMI are disabled and the next instruction is always executed. When the I bit is set by one of these instructions, the new value becomes valid two states after execution of the instruction ends.

### 5.7.3 Times when Interrupts Are Disabled

There are times when interrupt acceptance is disabled by the interrupt controller.

The interrupt controller disables interrupt acceptance for a 3-state period after the CPU has updated the mask level with an LDC, ANDC, ORC, or XORC instruction.

### 5.7.4 Interrupts during Execution of EEPMOV Instruction

Interrupt operation differs between the EEPMOV.B instruction and the EEPMOV.W instruction.

With the EEPMOV.B instruction, an interrupt request (including NMI) issued during the transfer is not accepted until the move is completed.

With the EEPMOV.W instruction, if an interrupt request is issued during the transfer, interrupt exception handling starts at a break in the transfer cycle. The PC value saved on the stack in this case is the address of the next instruction.

Therefore, if an interrupt is generated during execution of an EEPMOV.W instruction, the following coding should be used.

```
L1: EEPMOV.W
    MOV.W  R4, R4
    BNE   L1
```

### 5.7.5 IRQ Interrupt

When operating by clock input, acceptance of input to an IRQ is synchronized with the clock. In software standby mode and watch mode, the input is accepted asynchronously. For details on the input conditions, see section 22.4.2, Control Signal Timing.

### 5.7.6 NMI Interrupt Usage Notes

The NMI interrupt is part of the exception processing performed cooperatively by the LSI's internal interrupt controller and the CPU when the system is operating normally under the specified electrical conditions. No operations, including NMI interrupts, are guaranteed when operation is not normal (runaway status) due to software problems or abnormal input to the LSI's pins. In such cases, the LSI may be restored to the normal program execution state by applying an external reset.

## Section 6 Bus Controller

This LSI has a built-in bus controller (BSC) that manages the external address space divided into eight areas. The bus controller also has a bus arbitration function, and controls the operation of the internal bus masters: the CPU and DMA controller (DMAC).

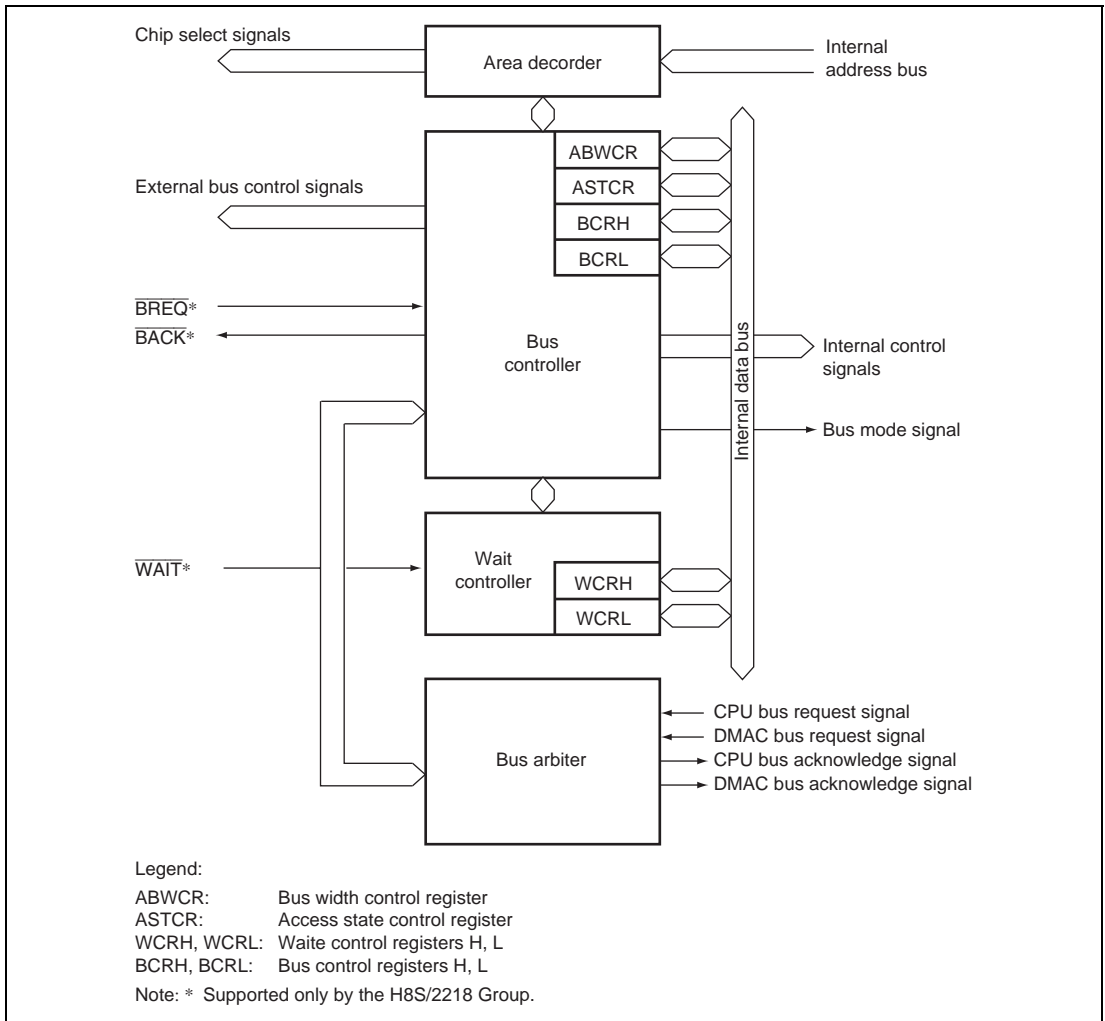
### 6.1 Features

- Manages external address space in area units
  - Manages the external space as 8 areas of 2-Mbytes
  - Bus specifications can be set independently for each area
  - Burst ROM interface can be set
- Basic bus interface\*<sup>1</sup>
  - Chip select ( $\overline{CS0}$  to  $\overline{CS5}$ ) can be output for areas 0 to 5\*<sup>2</sup>
  - 8-bit access or 16-bit access can be selected for each area
  - 2-state access or 3-state access can be selected for each area
  - Program wait states can be inserted for each area
- Burst ROM interface\*<sup>2</sup>
  - Burst ROM interface can be selected for area 0
  - One or two states can be selected for the burst cycle
- Idle cycle insertion\*<sup>2</sup>
  - Idle cycle can be inserted between consecutive read accesses to different areas
  - Idle cycle can be inserted before a write access to an external area immediately after a read access to an external area
- Bus arbitration
  - The on-chip bus arbiter arbitrates bus mastership among CPU and DMAC
- Other features
  - External bus release function\*<sup>2</sup>

Notes: 1. Chip select  $\overline{CS6}$  in area 6 is for the on-chip USB. Therefore it cannot be used as an external area. 8-bit bus mode, 3-state access, and no program wait state should be set for area 6. Access to the RTC related registers (address: H'FFFF40 to H'FFFF5F) follows the specification of area 7. 8-bit access, 3-state access, and no program wait state should be set for area 7.

2. These functions are not available in the H8S/2212 Group.

Figure 6.1 shows a block diagram of the bus controller.



**Figure 6.1 Block Diagram of Bus Controller**

## 6.2 Input/Output Pins

Table 6.1 summarizes the pins of the bus controller.

These pins are supported only by the H8S/2218 Group.

**Table 6.1 Pin Configuration**

Name	Symbol	I/O	Function
Address strove	$\overline{AS}$	Output	Strobe signal indicating that address output on address bus is enabled.
Read	$\overline{RD}$	Output	Strobe signal indicating that external space is being read.
High write	$\overline{HWR}$	Output	Strobe signal indicating that external space is to be written, and upper half (D15 to D8) of data bus is enabled.
Low write	$\overline{LWR}$	Output	Strobe signal indicating that external space is to be written, and lower half (D7 to D0) of data bus is enabled.
Chip select 0 to 5	$\overline{CS0}$ to $\overline{CS5}$	Output	Strobe signal indicating that areas 0 to 5 are selected.
Wait	$\overline{WAIT}$	Input	Wait request signal when accessing external 3-state access space.
Bus request	$\overline{BREQ}$	Input	Request signal that releases bus to external device.
Bus request acknowledge	$\overline{BACK}$	Output	Acknowledge signal indicating that bus has been released.

## 6.3 Register Descriptions

The following shows the registers of the bus controller.

- Bus width control register (ABWCR)
- Access state control register (ASTCR)
- Wait control register H (WCRH)
- Wait control register L (WCRL)
- Bus control register H (BCRH)
- Bus control register L (BCRL)
- Pin function control register (PFCR)

### 6.3.1 Bus Width Control Register (ABWCR)

ABWCR designates each area for either 8-bit access or 16-bit access.

ABWCR sets the data bus width for the external memory space. The bus width for on-chip memory and internal I/O registers except for the on-chip USB and RTC is fixed regardless of the settings in ABWCR.

Bit	Bit Name	Initial Value	R/W	Description
7	ABW7* <sup>2</sup>	1/0* <sup>1</sup>	R/W	Area 7 to 0 Bus Width Control:
6	ABW6* <sup>2</sup>	1/0* <sup>1</sup>	R/W	These bits select whether the corresponding area is to be designated for 8-bit access or 16-bit access.
5	ABW5	1/0* <sup>1</sup>	R/W	
4	ABW4	1/0* <sup>1</sup>	R/W	0: Area n is designated for 16-bit access
3	ABW3	1/0* <sup>1</sup>	R/W	1: Area n is designated for 8-bit access
2	ABW2	1/0* <sup>1</sup>	R/W	Legend: n = 7 to 0
1	ABW1	1/0* <sup>1</sup>	R/W	
0	ABW0	1/0* <sup>1</sup>	R/W	

- Notes:
1. In modes 5 to 7, initial value of each bit is 1. In mode 4, initial value of each bit is 0. These bits should be set to 1 in the H8S/2212 Group.
  2. The on-chip USB and on-chip RTC are allocated to area 6 and area 7, respectively. Therefore, these bits should be set to 1.

### 6.3.2 Access State Control Register (ASTCR)

ASTCR designates each area as either a 2-state access space or a 3-state access space.

ASTCR sets the number of access states for the external memory space. The number of access states for on-chip memory and internal I/O registers except for the on-chip USB is fixed regardless of the settings in ASTCR.

Bit	Bit Name	Initial Value	R/W	Description
7	AST7*	1	R/W	Area 7 to 0 Access State Control:
6	AST6*	1	R/W	These bits select whether the corresponding area is to be designated as a 2-state access space or a 3-state access space. Wait state insertion is enabled or disabled at the same time.
5	AST5	1	R/W	
4	AST4	1	R/W	0: Area n is designated for 2-state access Wait state insertion in area n external space is disabled
3	AST3	1	R/W	
2	AST2	1	R/W	1: Area n is designated for 3-state access Wait state insertion in area n external space is enabled
1	AST1	1	R/W	
0	AST0	1	R/W	

Legend: n = 7 to 0

Note: \* The on-chip USB and on-chip RTC are allocated to area 6 and area 7, respectively. Therefore, these bits should be set to 1.

### 6.3.3 Wait Control Registers H and L (WCRH, WCRL)

WCRH and WCRL select the number of program wait states for each area.

Program waits are not inserted in the case of on-chip memory or internal I/O registers except for the on-chip USB.

- WCRH

Bit	Bit Name	Initial Value	R/W	Description
7	W71*	1	R/W	Area 7 Wait Control 1 and 0
6	W70*	1	R/W	These bits select the number of program wait states when area 7 in external space is accessed while the AST7 bit in ASTCR is set to 1. 00: Program wait not inserted when external space area 7 is accessed 01: 1 program wait state inserted when external space area 7 is accessed 10: 2 program wait states inserted when external space area 7 is accessed 11: 3 program wait states inserted when external space area 7 is accessed
5	W61*	1	R/W	Area 6 Wait Control 1 and 0
4	W60*	1	R/W	These bits select the number of program wait states when area 6 in external space is accessed while the AST6 bit in ASTCR is set to 1. 00: Program wait not inserted when external space area 6 is accessed 01: 1 program wait state inserted when external space area 6 is accessed 10: 2 program wait states inserted when external space area 6 is accessed 11: 3 program wait states inserted when external space area 6 is accessed

Note: \* The on-chip USB and on-chip RTC are allocated to area 6 and area 7, respectively. Therefore, these bits should be set to 0.



Bit	Bit Name	Initial Value	R/W	Description
3	W51	1	R/W	Area 5 Wait Control 1 and 0
2	W50	1	R/W	<p>These bits select the number of program wait states when area 5 in external space is accessed while the AST5 bit in ASTCR is set to 1.</p> <p>00: Program wait not inserted when external space area 5 is accessed</p> <p>01: 1 program wait state inserted when external space area 5 is accessed</p> <p>10: 2 program wait states inserted when external space area 5 is accessed</p> <p>11: 3 program wait states inserted when external space area 5 is accessed</p>
1	W41	1	R/W	Area 4 Wait Control 1 and 0
0	W40	1	R/W	<p>These bits select the number of program wait states when area 4 in external space is accessed while the AST4 bit in ASTCR is set to 1.</p> <p>00: Program wait not inserted when external space area 4 is accessed</p> <p>01: 1 program wait state inserted when external space area 4 is accessed</p> <p>10: 2 program wait states inserted when external space area 4 is accessed</p> <p>11: 3 program wait states inserted when external space area 4 is accessed</p>

- WCRL

Bit	Bit Name	Initial Value	R/W	Description
7	W31	1	R/W	Area 3 Wait Control 1 and 0
6	W30	1	R/W	<p>These bits select the number of program wait states when area 3 in external space is accessed while the AST3 bit in ASTCR is set to 1.</p> <p>00: Program wait not inserted when external space area 3 is accessed</p> <p>01: 1 program wait state inserted when external space area 3 is accessed</p> <p>10: 2 program wait states inserted when external space area 3 is accessed</p> <p>11: 3 program wait states inserted when external space area 3 is accessed</p>
5	W21	1	R/W	Area 2 Wait Control 1 and 0
4	W20	1	R/W	<p>These bits select the number of program wait states when area 2 in external space is accessed while the AST2 bit in ASTCR is set to 1.</p> <p>00: Program wait not inserted when external space area 2 is accessed</p> <p>01: 1 program wait state inserted when external space area 2 is accessed</p> <p>10: 2 program wait states inserted when external space area 2 is accessed</p> <p>11: 3 program wait states inserted when external space area 2 is accessed</p>

Bit	Bit Name	Initial Value	R/W	Description
3	W11	1	R/W	Area 1 Wait Control 1 and 0
2	W10	1	R/W	<p>These bits select the number of program wait states when area 1 in external space is accessed while the AST1 bit in ASTCR is set to 1.</p> <p>00: Program wait not inserted when external space area 1 is accessed</p> <p>01: 1 program wait state inserted when external space area 1 is accessed</p> <p>10: 2 program wait states inserted when external space area 1 is accessed</p> <p>11: 3 program wait states inserted when external space area 1 is accessed</p>
1	W01	1	R/W	Area 0 Wait Control 1 and 0
0	W00	1	R/W	<p>These bits select the number of program wait states when area 0 in external space is accessed while the AST0 bit in ASTCR is set to 1.</p> <p>00: Program wait not inserted when external space area 0 is accessed</p> <p>01: 1 program wait state inserted when external space area 0 is accessed</p> <p>10: 2 program wait states inserted when external space area 0 is accessed</p> <p>11: 3 program wait states inserted when external space area 0 is accessed</p>

### 6.3.4 Bus Control Register H (BCRH)

BCRH selects enabling or disabling of idle cycle insertion, and the memory interface for area 0. This register should be set initial value and not be modified in the H8S/2212 Group.

Bit	Bit Name	Initial Value	R/W	Description
7	ICIS1	1	R/W	<p>Idle Cycle Insert 1:</p> <p>Selects whether or not one idle cycle state is to be inserted between bus cycles when successive external read cycles are performed in different areas.</p> <p>0: Idle cycle not inserted in case of successive external read cycles in different areas</p> <p>1: Idle cycle inserted in case of successive external read cycles in different areas</p>
6	ICIS0	1	R/W	<p>Idle Cycle Insert 0:</p> <p>Selects whether or not one idle cycle state is to be inserted between bus cycles when successive external read and write cycles are performed.</p> <p>0: Idle cycle not inserted in case of successive external read and write cycles</p> <p>1: Idle cycle inserted in case of successive external read and write cycles</p>
5	BRSTRM	0	R/W	<p>Burst ROM enable:</p> <p>Selects whether area 0 is used as a burst ROM interface.</p> <p>0: Area 0 is basic bus interface</p> <p>1: Area 0 is burst ROM interface</p>
4	BRSTS1	1	R/W	<p>Burst Cycle Select 1:</p> <p>Selects the number of burst cycles for the burst ROM interface.</p> <p>0: Burst cycle comprises 1 state</p> <p>1: Burst cycle comprises 2 states</p>
3	BRSTS0	0	R/W	<p>Burst Cycle Select 0:</p> <p>Selects the number of words that can be accessed in a burst ROM interface burst access.</p> <p>0: Max. 4 words in burst access</p> <p>1: Max. 8 words in burst access</p>
2 to 0	–	All 0	R/W	<p>Reserved</p> <p>The write value should always be 0.</p>

### 6.3.5 Bus Control Register L (BCRL)

BCRL performs selection of the external bus-released state protocol, and enabling or disabling of  $\overline{\text{WAIT}}$  pin input.

The functions selected by this register are available only in the H8S/2218 Group. This register should not be modified in the H8S/2212 Group.

Bit	Bit Name	Initial Value	R/W	Description
7	BRLE*	0	R/W	Bus Release Enable Enables or disables external bus release. 0: External bus release is disabled. $\overline{\text{BREQ}}$ and $\overline{\text{BACK}}$ can be used as I/O ports. 1: External bus release is enabled.
6	–	0	R/W	Reserved The write value should always be 0.
5	–	0	–	Reserved This bit is always read as 0 and cannot be modified.
4	–	0	R/W	Reserved The write value should always be 0.
3	–	1	R/W	Reserved The write value should always be 1.
2, 1	–	All 0	R/W	Reserved The write value should always be 0.
0	WAITE*	0	R/W	WAIT Pin Enable Selects enabling or disabling of wait input by the $\overline{\text{WAIT}}$ pin. 0: Wait input by $\overline{\text{WAIT}}$ pin disabled. $\overline{\text{WAIT}}$ pin can be used as I/O port. 1: Wait input by $\overline{\text{WAIT}}$ pin enabled.

Note: \* These bits should be set to 0 in the H8S/2212 Group.

### 6.3.6 Pin Function Control Register (PFCR)

PFCR performs address output control in external extended mode. When using the USB with the emulator (E6000), enable the A8 and A9 output by setting AE3 to AE0 to 0010.

Bit	Bit Name	Initial Value	R/W	Description
7 to	—	Undefined	R/W	Reserved
4				The write value should always be 0.
3	AE3	1/0*	R/W	Address Output Enable 3 to 0
2	AE2	1/0*	R/W	These bits select enabling or disabling of address outputs A8 to A23 in ROMless extended mode and modes with ROM.
1	AE1	0	R/W	
0	AE0	1/0*	R/W	When a pin is enabled for address output, the address is output regardless of the corresponding DDR setting. When a pin is disabled for address output, it becomes an output port when the corresponding DDR bit is set to 1. 0000: A8 to A23 output disabled (initial value of mode 6 and 7) 0001: A8 output enabled; A9 to A23 output disabled 0010: A8, A9 output enabled; A10 to A23 output disabled 0011: A8 to A10 output enabled; A11 to A23 output disabled 0100: A8 to A11 output enabled; A12 to A23 output disabled 0101: A8 to A12 output enabled; A13 to A23 output disabled 0110: A8 to A13 output enabled; A14 to A23 output disabled 0111: A8 to A14 output enabled; A15 to A23 output disabled 1000: A8 to A15 output enabled; A16 to A23 output disabled 1001: A8 to A16 output enabled; A17 to A23 output disabled 1010: A8 to A17 output enabled; A18 to A23 output disabled 1011: A8 to A18 output enabled; A19 to A23 output disabled 1100: A8 to A19 output enabled; A20 to A23 output disabled 1101: A8 to A20 output enabled; A21 to A23 output disabled (initial value of modes 4 and 5) 1110: A8 to A21 output enabled; A22, A23 output disabled 1111: A8 to A23 output enabled

Note: \* In modes 4 and 5, initial value of each bit is 1. In modes 6 and 7, initial value of each bit is 0.

## 6.4 Bus Control

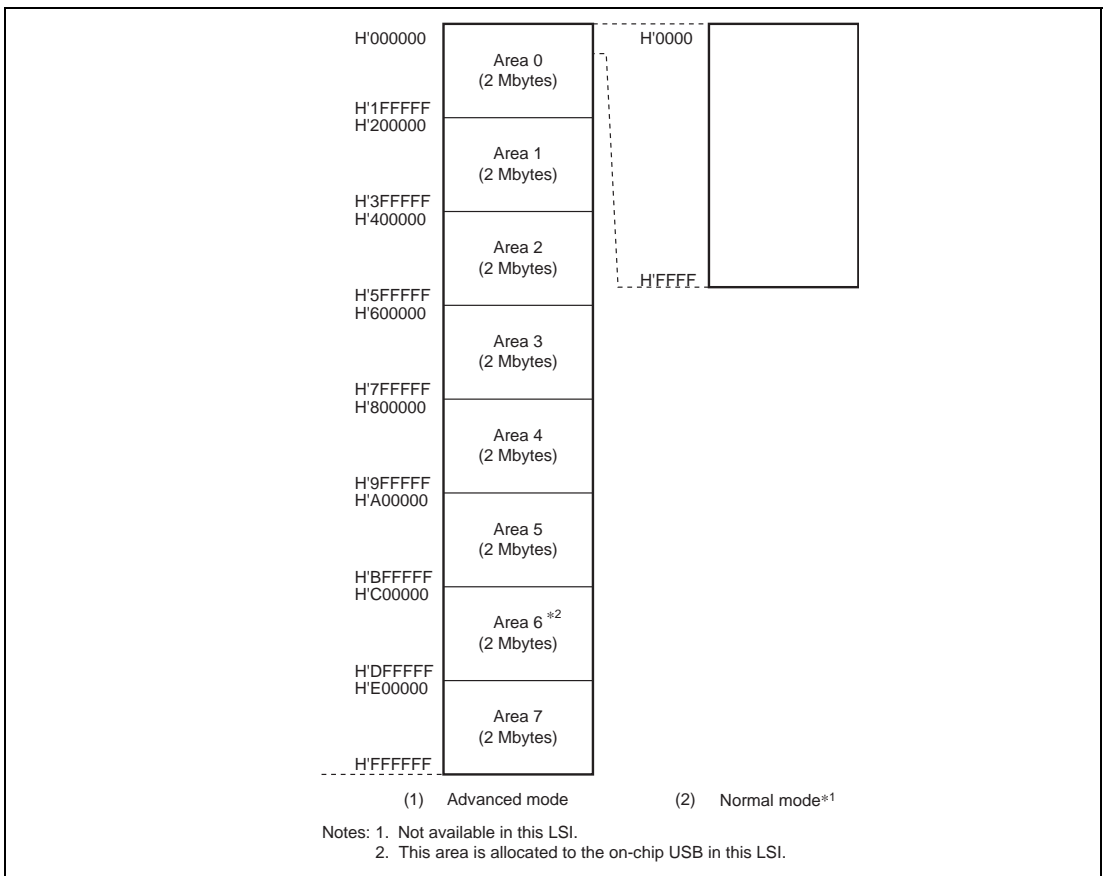
### 6.4.1 Area Divisions

In advanced mode, the bus controller partitions the 16 Mbytes address space into eight areas, 0 to 7, in 2-Mbyte units, and performs bus control for external space in area units. In normal mode\*, it controls a 64-kbyte address space comprising part of area 0.

Figure 6.2 shows an outline of the memory map.

Chip select signals ( $\overline{CS0}$  to  $\overline{CS5}$ ) can be output for areas 0 to 5.

Note: \* Not available in this LSI.



**Figure 6.2 Overview of Area Divisions**

### 6.4.2 Bus Specifications

The external space bus specifications consist of three elements: bus width, number of access states, and number of program wait states.

The bus width and number of access states for memory and internal I/O registers except for the on-chip USB and RTC are fixed, and are not affected by the bus controller.

**Bus Width:** A bus width of 8 or 16 bits can be selected with ABWCR. An area for which an 8-bit bus is selected functions as an 8-bit access space, and an area for which a 16-bit bus is selected functions as a 16-bit access space.

If all areas are designated for 8-bit access, 8-bit bus mode is set; if any area is designated for 16-bit access, 16-bit bus mode is set. When the burst ROM interface is designated, 16-bit bus mode is always set. 8-bit bus mode should be set for area 6 and area 7 in this LSI.

**Number of Access States:** Two or three access states can be selected with ASTCR.

An area for which 2-state access is selected functions as a 2-state access space, and an area for which 3-state access is selected functions as a 3-state access space.

With the burst ROM interface, the number of access states may be determined without regard to ASTCR.

When 2-state access space is designated, wait insertion is disabled.

Area 6 and area 7 should be set to function as a 3-state access space in this LSI.

**Number of Program Wait States:** When 3-state access space is designated by ASTCR, the number of program wait states to be inserted automatically is selected with WCRH and WCRL.

From 0 to 3 program wait states can be selected.

The number of program wait states in area 6 and area 7 should be set to 0 in this LSI.



**Table 6.2 Bus Specifications for Each Area (Basic Bus Interface)**

ABWCR	ASTCR	WCRH, WCRL		Bus Specifications (Basic Bus Interface)		
		Wn1	Wn0	Bus Width	Number of Access States	Number of Program Wait States
0	0	—	—	16	2	0
	1	0	0		3	0
			1			1
		1	0			2
			1			3
1	0	—	—	8	2	0
	1	0	0		3	0
			1			1
		1	0			2
			1			3

### 6.4.3 Bus Interface for Each Area

The initial state of each area is basic bus interface, 3-state access space. The initial bus width is selected according to the operating mode. The bus specifications described here cover basic items only, and the sections on each memory interface (section 6.6, Basic Bus Interface and section 6.7, Burst ROM Interface) should be referred to for further details. Note that the ROM is always enabled and no external extended mode in the H8S/2212 Group.

**Area 0:** Area 0 includes on-chip ROM, and in ROM-disabled extended mode, all of area 0 is external space. In ROM-enabled extended mode, the space excluding on-chip ROM is external space.

When area 0 external space is accessed, the  $\overline{CS0}$  signal can be output.

Either basic bus interface or burst ROM interface can be selected for area 0.

**Areas 1 to 6:** In external extended mode, all of areas 1 to 6 is external space. When area 1 to 5 external space is accessed, the  $\overline{CS1}$  to  $\overline{CS5}$  pin signals respectively can be output. Only the basic bus interface can be used for areas 1 to 5. Area 6 is only for the on-chip USB. For details, see section 14, Universal Serial Bus (USB).

**Area 7:** Area 7 includes the on-chip RAM and internal I/O registers. In external extended mode, the space excluding the reserved area (for details, see section 3.4, Memory Map in Each Operating Mode) the on-chip RAM and internal I/O registers except on-chip RTC, is external space. The on-chip RAM is enabled when the RAME bit in the system control register (SYSCR) is set to 1; when

the RAME bit is cleared to 0, the on-chip RAM is disabled and the corresponding space becomes external space.

Only the basic bus interface can be used for the area 7.

#### 6.4.4 Chip Select Signals

In the H8S/2218 Group chip select signals ( $\overline{CS0}$  to  $\overline{CS5}$ ) can be output to areas 0 to 5, the signal being driven low when the corresponding external space area is accessed. Figure 6.3 shows an example of  $\overline{CSn}$  ( $n = 0$  to 5) output timing. Enabling or disabling of the  $\overline{CSn}$  signal is performed by setting the data direction register (DDR) for the port corresponding to the particular  $\overline{CSn}$  pin.

In ROM-disabled extended mode, the  $\overline{CS0}$  pin is placed in the output state after a power-on reset. Pins  $\overline{CS1}$  to  $\overline{CS5}$  are placed in the input state after a power-on reset, and so the corresponding DDR should be set to 1 when outputting signals  $\overline{CS1}$  to  $\overline{CS5}$ .

In ROM-enabled extended mode, pins  $\overline{CS0}$  to  $\overline{CS5}$  are all placed in the input state after a power-on reset, and so the corresponding DDR should be set to 1 when outputting signals  $\overline{CS0}$  to  $\overline{CS5}$ . For details, see section 8, I/O Ports.

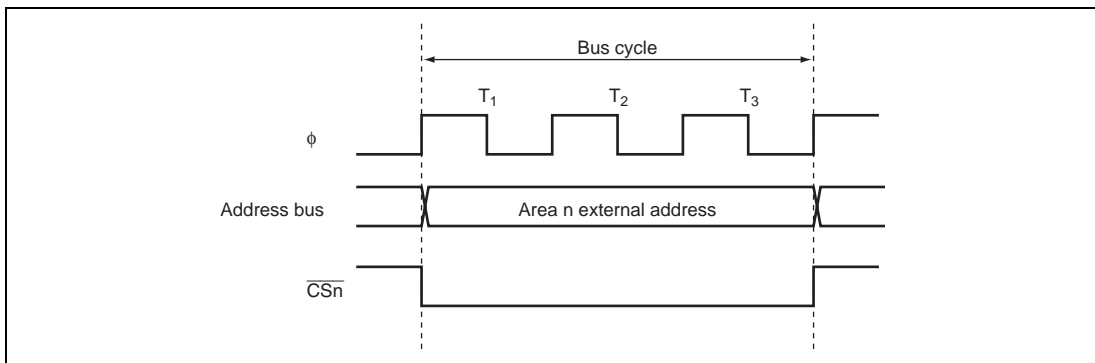


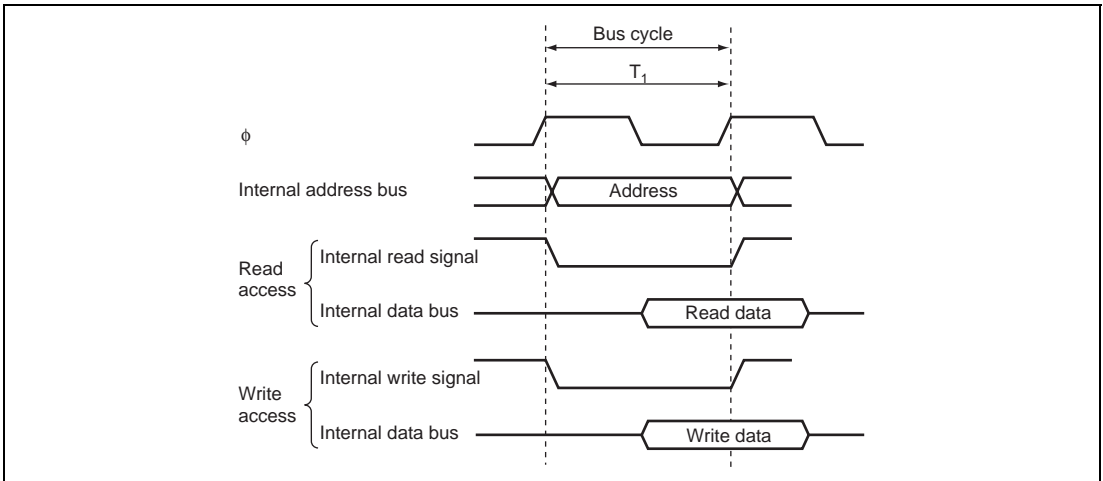
Figure 6.3  $\overline{CSn}$  Signal Output Timing ( $n = 0$  to 5)

## 6.5 Basic Timing

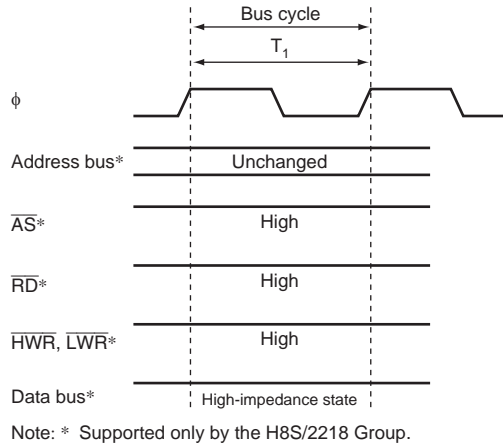
The CPU is driven by a system clock ( $\phi$ ), denoted by the symbol  $\phi$ . The period from one rising edge of  $\phi$  to the next is referred to as a "state." The memory cycle or bus cycle consists of one, two, or three states. Different methods are used to access on-chip memory, on-chip peripheral modules, and the external address space.

### 6.5.1 On-Chip Memory (ROM, RAM) Access Timing

On-chip memory is accessed in one state. The data bus is 16 bits wide, permitting both byte and word transfer instruction. Figure 6.4 shows the on-chip memory access cycle. Figure 6.5 shows the pin states.



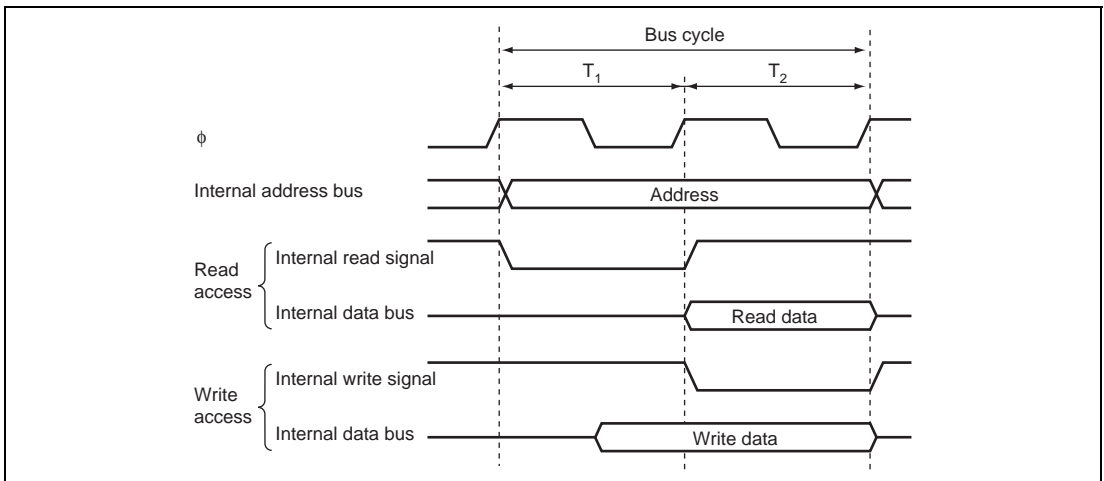
**Figure 6.4 On-Chip Memory Access Cycle**



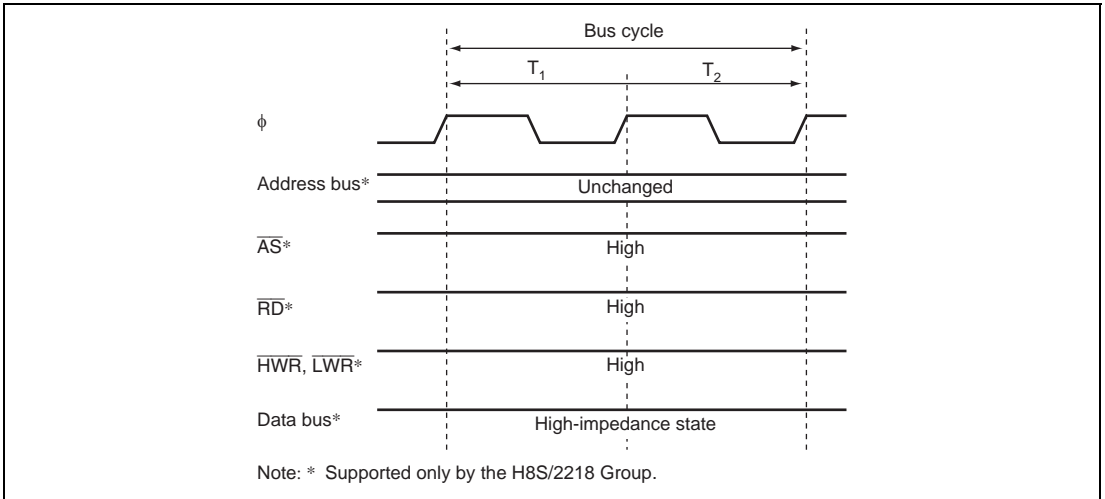
**Figure 6.5 Pin States during On-Chip Memory Access**

### 6.5.2 On-Chip Peripheral Module Access Timing

The on-chip peripheral modules are accessed in two states except on-chip USB and RTC. The data bus is either 8 bits or 16 bits wide, depending on the particular internal I/O register being accessed. Figure 6.6 shows the access timing for the on-chip peripheral modules. Figure 6.7 shows the pin states.



**Figure 6.6 On-Chip Peripheral Module Access Cycle**



**Figure 6.7 Pin States during On-Chip Peripheral Module Access**

### 6.5.3 External Address Space Access Timing

The external address space is accessed with an 8-bit or 16-bit data bus width in a two-state or three-state bus cycle. In three-state access, wait states can be inserted. For further details, refer to section 6.6.3, Basic Timing.

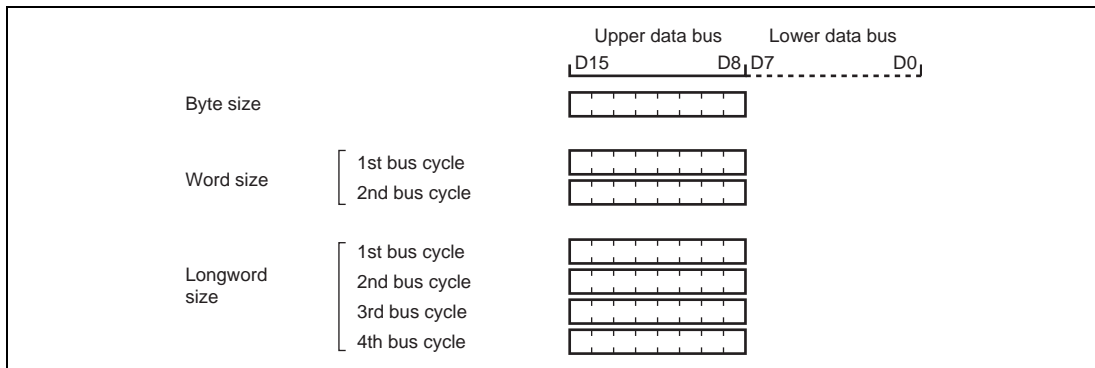
## 6.6 Basic Bus Interface

The basic bus interface enables direct connection of ROM, SRAM, and so on.

### 6.6.1 Data Size and Data Alignment (Supported Only by the H8S/2218 Group)

Data sizes for the CPU and other internal bus masters are byte, word, and longword. The bus controller has a data alignment function, and when accessing external space, controls whether the upper data bus (D15 to D8) or lower data bus (D7 to D0) is used according to the bus specifications for the area being accessed (8-bit access space or 16-bit access space) and the data size.

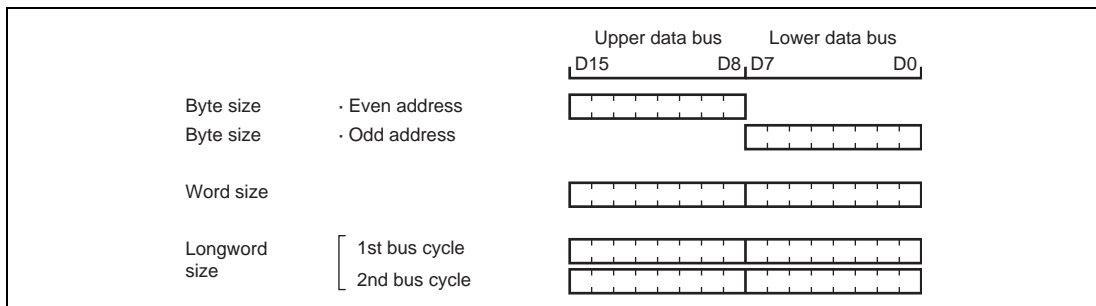
**8-Bit Access Space:** Figure 6.8 illustrates data alignment control for the 8-bit access space. With the 8-bit access space, the upper data bus (D15 to D8) is always used for accesses. The amount of data that can be accessed at one time is one byte: a word transfer instruction is performed as two-byte accesses, and a longword transfer instruction, as four-byte accesses.



**Figure 6.8 Access Sizes and Data Alignment Control (8-Bit Access Space)**

**16-Bit Access Space:** Figure 6.9 illustrates data alignment control for the 16-bit access space. With the 16-bit access space, the upper data bus (D15 to D8) and lower data bus (D7 to D0) are used for accesses. The amount of data that can be accessed at one time is one byte or one word, and a longword transfer instruction is executed as two word transfer instructions.

In byte access, whether the upper or lower data bus is used is determined by whether the address is even or odd. The upper data bus is used for an even address, and the lower data bus for an odd address.



**Figure 6.9 Access Sizes and Data Alignment Control (16-Bit Access Space)**

### 6.6.2 Valid Strobes

Table 6.3 shows the data buses used and valid strobes for the access spaces in the H8S/2218 Group.

In a read, the  $\overline{RD}$  signal is valid without discrimination between the upper and lower halves of the data bus.

In a write, the  $\overline{HWR}$  signal is valid for the upper half of the data bus, and the  $\overline{LWR}$  signal for the lower half.

The  $\overline{RD}$ ,  $\overline{HWR}$ , and  $\overline{LWR}$  signals are not available in the H8S/2212 Group.

**Table 6.3 Data Buses Used and Valid Strobes**

Area	Access Size	Read/Write	Address	Valid Strobe	Upper Data Bus (D15 to D8)	Lower Data Bus (D7 to D0)
8-bit access space	Byte	Read	–	$\overline{RD}$	Valid	Invalid
		Write	–	$\overline{HWR}$		Hi-Z
16-bit access space	Byte	Read	Even	$\overline{RD}$	Valid	Invalid
			Odd		Invalid	Valid
	Write	Even	$\overline{HWR}$	Valid	Hi-Z	
		Odd	$\overline{LWR}$	Hi-Z	Valid	
Word	Read	–	$\overline{RD}$	Valid	Valid	
		Write	–	$\overline{HWR}$ , $\overline{LWR}$		

Notes:

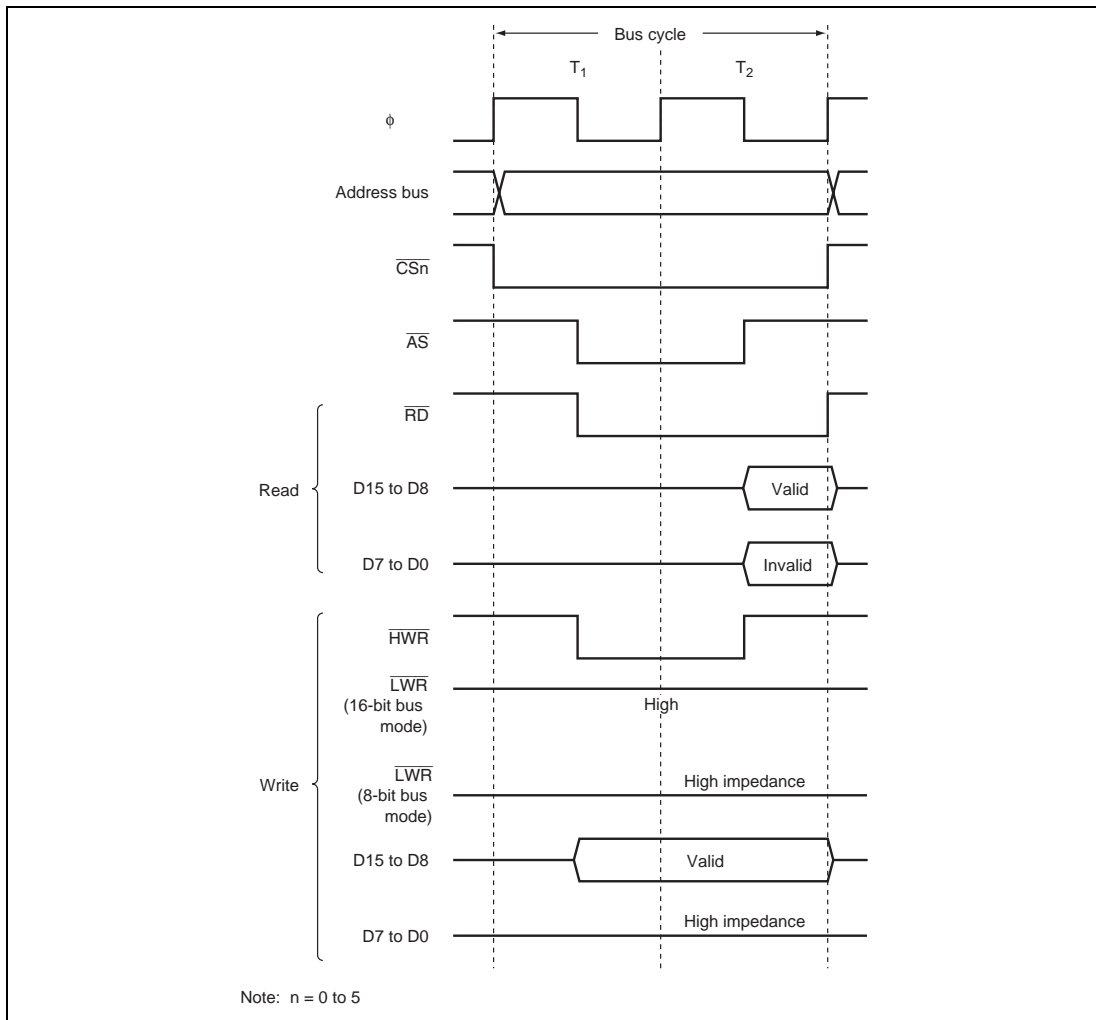
Hi-Z: High impedance.

Invalid: Input state: input value is ignored.

### 6.6.3 Basic Timing

**8-Bit 2-State Access Space:** Figure 6.10 shows the bus timing for an 8-bit 2-state access space in the H8S/2218 Group. When an 8-bit access space is accessed, the upper half (D15 to D8) of the data bus is used.

Wait states cannot be inserted.

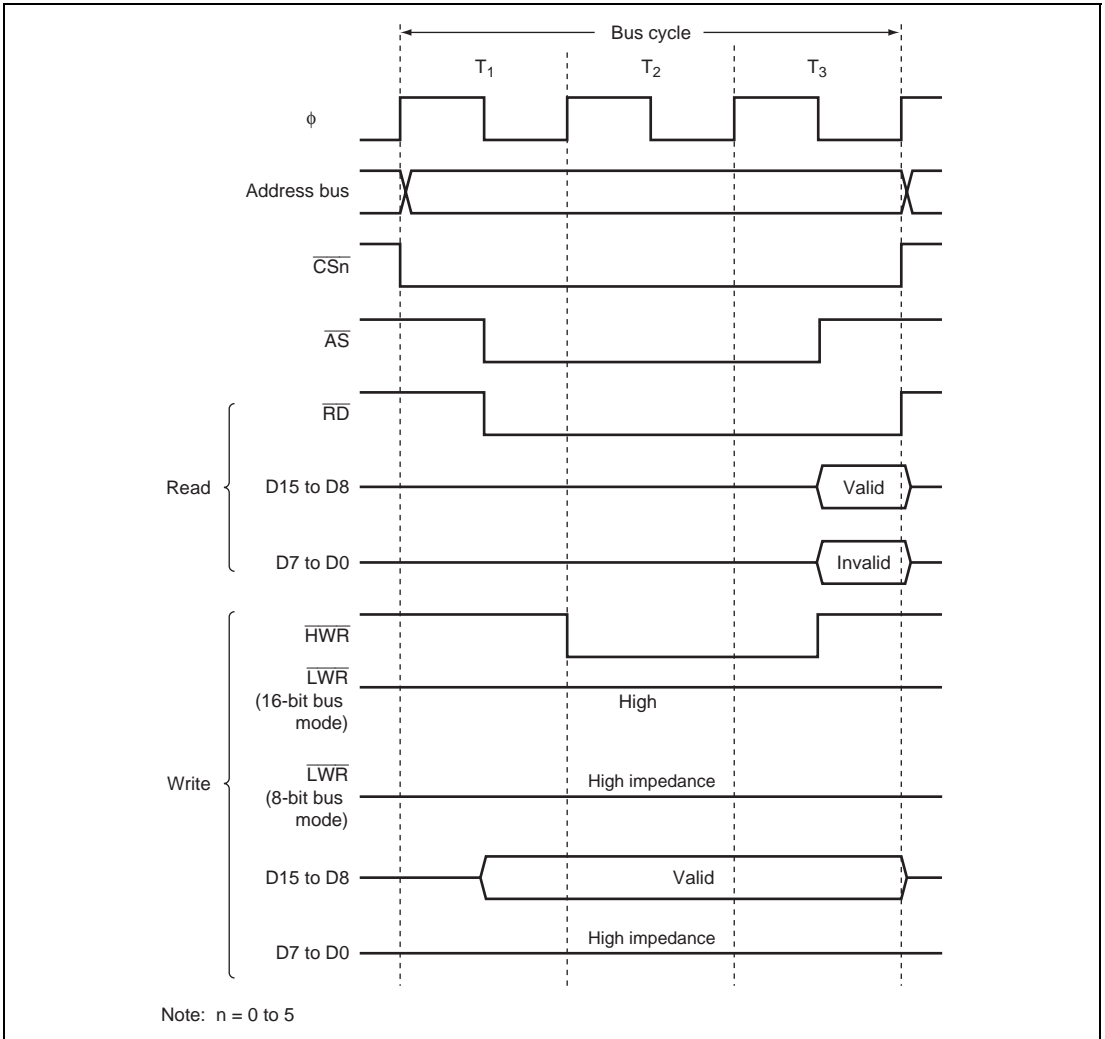


**Figure 6.10 Bus Timing for 8-Bit 2-State Access Space**



**8-Bit 3-State Access Space (Except Area 6):** Figure 6.11 shows the bus timing for an 8-bit 3-state access space in the H8S/2218 Group. When an 8-bit access space is accessed, the upper half (D15 to D8) of the data bus is used.

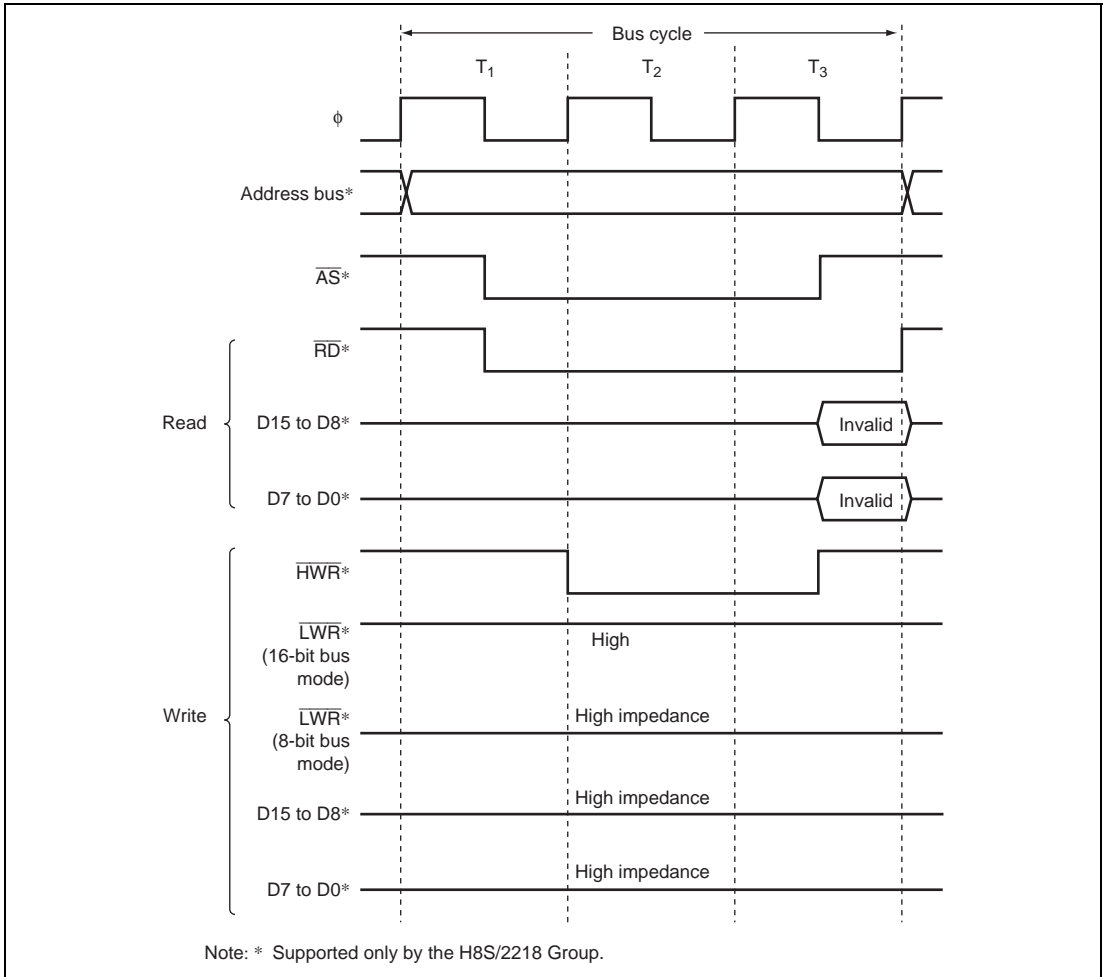
Wait states can be inserted.



**Figure 6.11 Bus Timing for 8-Bit 3-State Access Space (Except Area 6)**

**8-Bit 3-State Access Space (Area 6 and RTC):** Figure 6.12 shows the bus timing for area 6 and RTC area (address = H'FFFF40 to H'FFFF5F). When the areas are accessed, the data bus cannot be used.

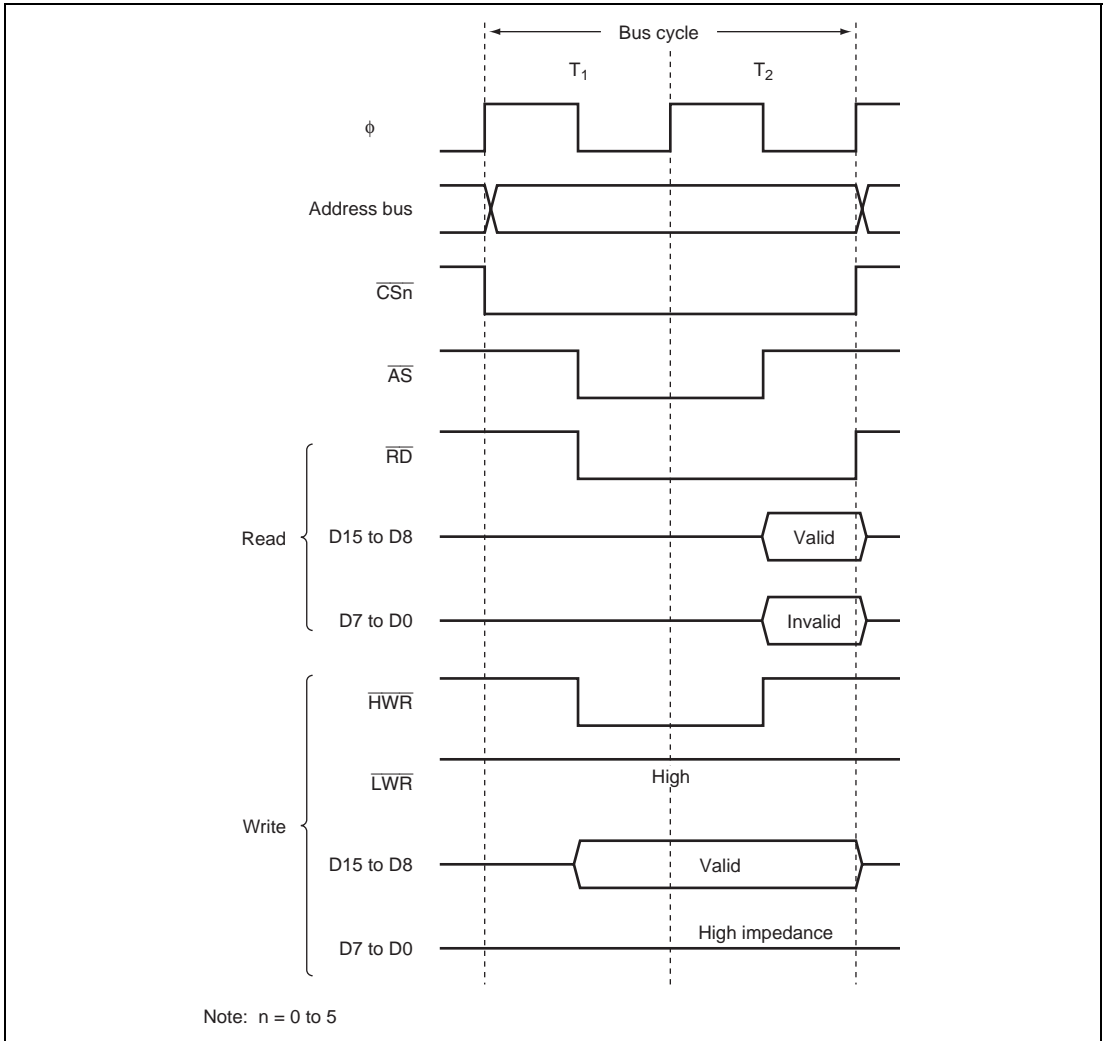
Wait states cannot be inserted.



**Figure 6.12 Bus Timing for Area 6 and RTC**

**16-Bit 2-State Access Space:** Figures 6.13 to 6.15 show bus timings for a 16-bit 2-state access space in the H8S/2218 Group. When a 16-bit access space is accessed, the upper half (D15 to D8) of the data bus is used for the even address, and the lower half (D7 to D0) for the odd address.

Wait states cannot be inserted.



**Figure 6.13 Bus Timing for 16-Bit 2-State Access Space (1) (Even Address Byte Access)**

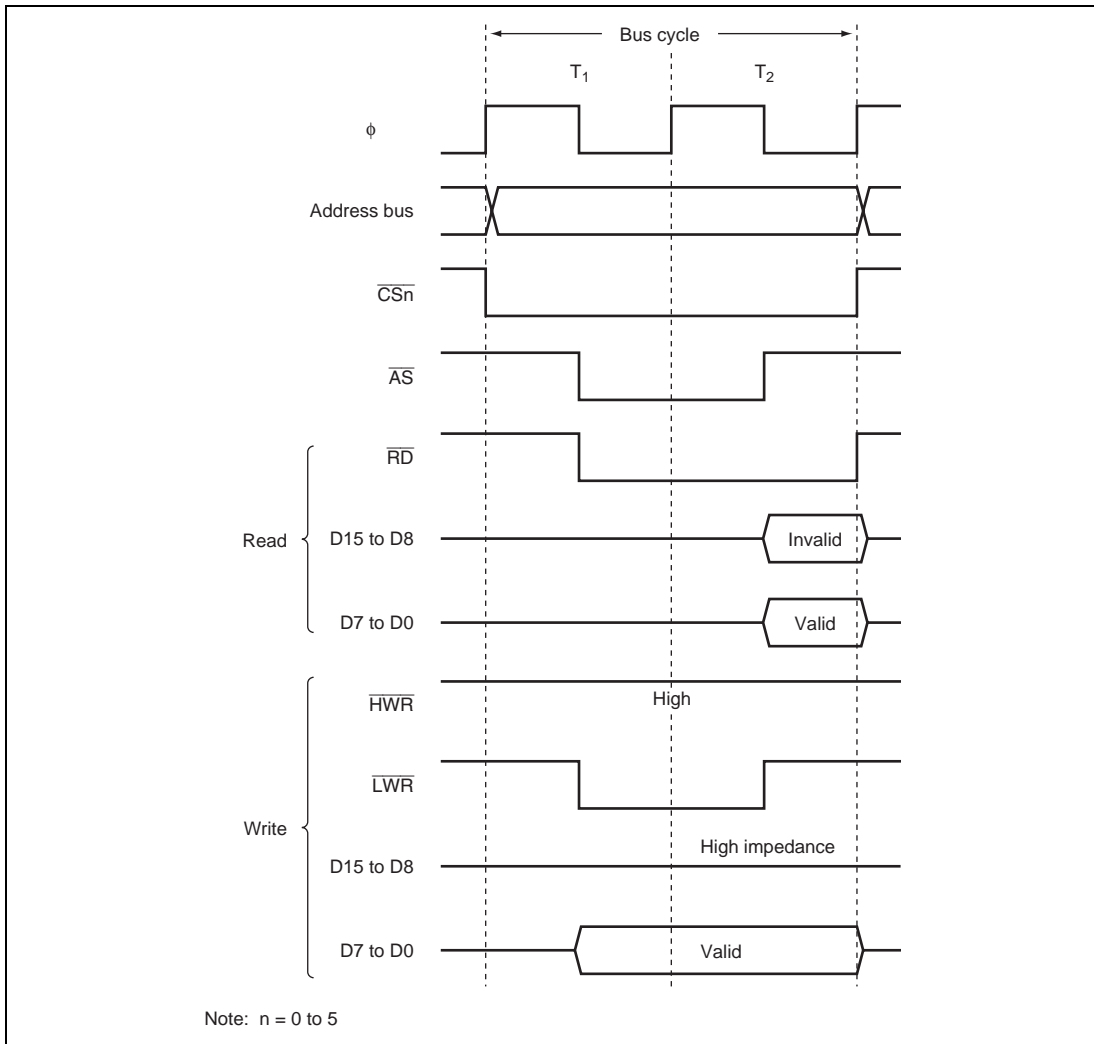
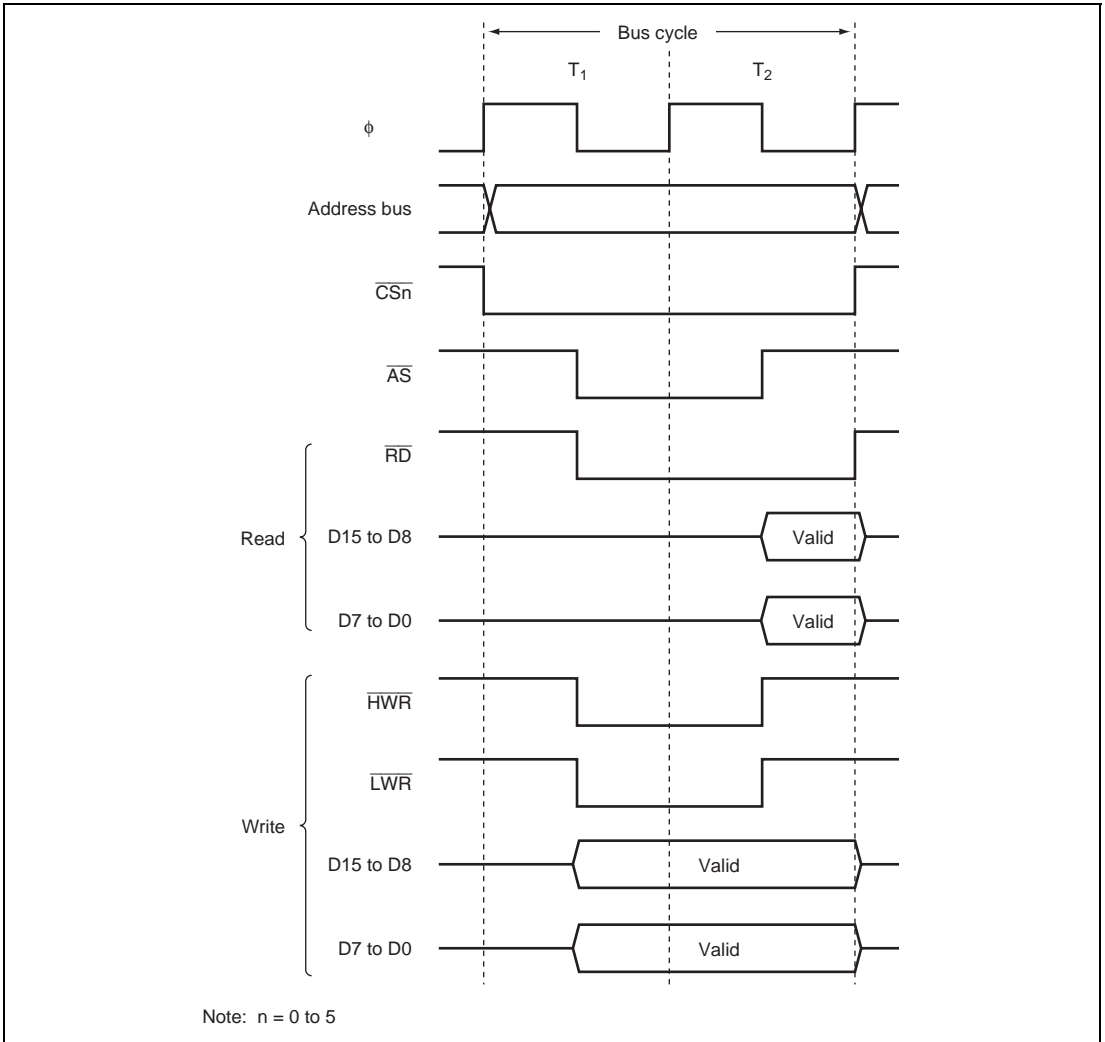


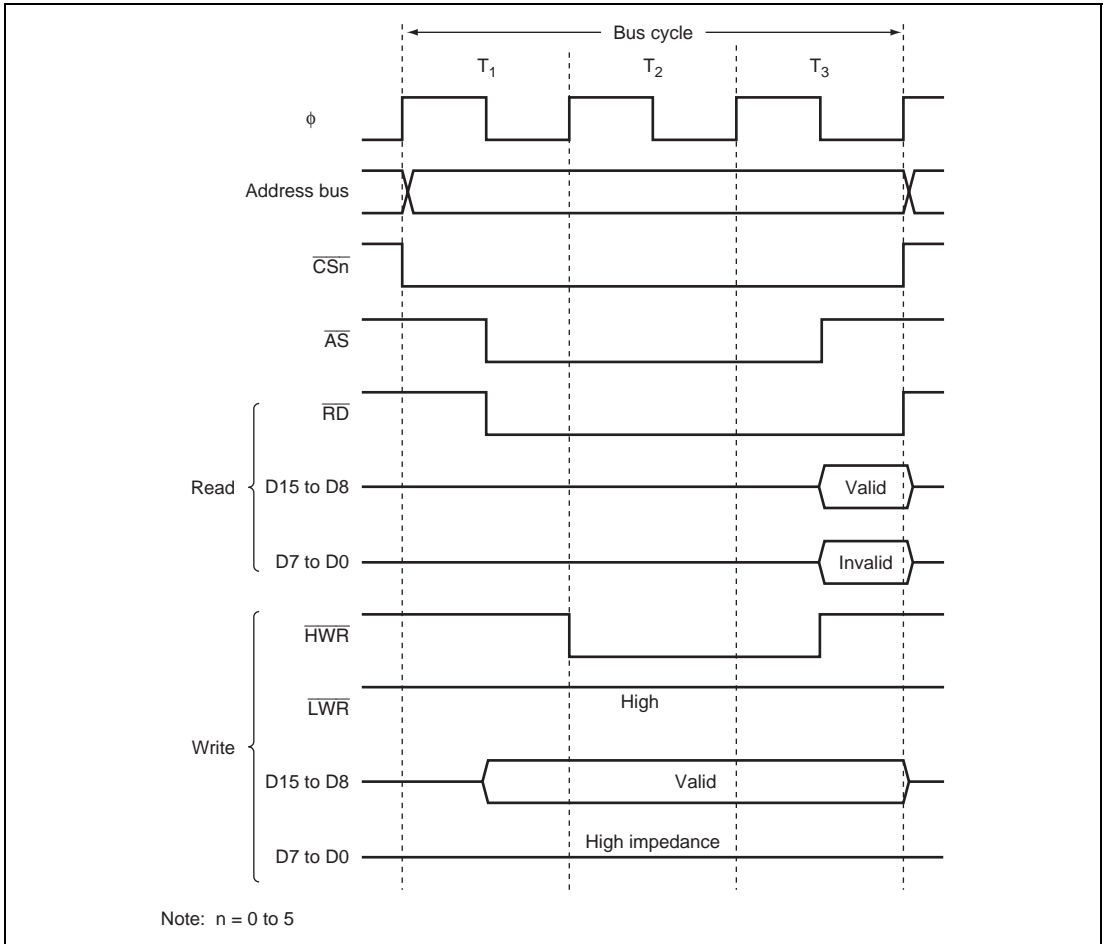
Figure 6.14 Bus Timing for 16-Bit 2-State Access Space (2) (Odd Address Byte Access)



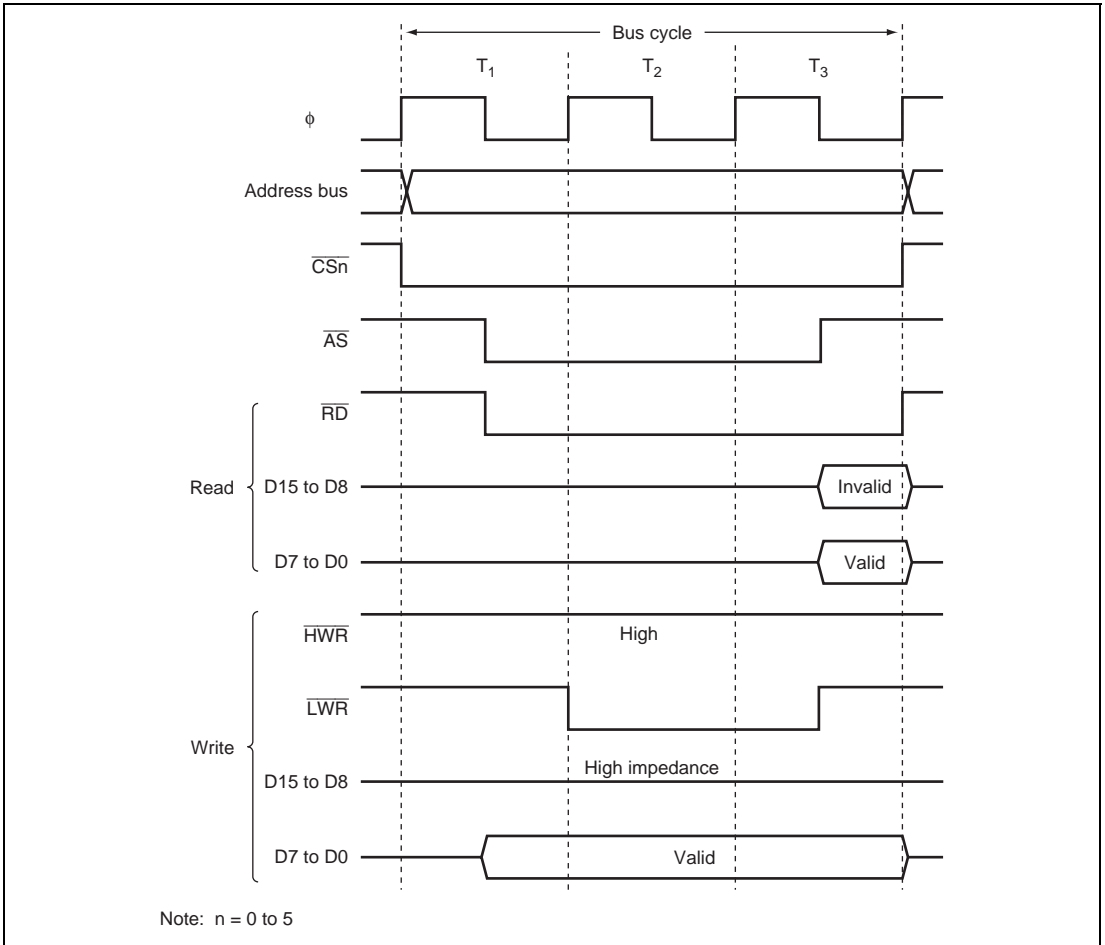
**Figure 6.15 Bus Timing for 16-Bit 2-State Access Space (3) (Word Access)**

**16-Bit 3-State Access Space:** Figures 6.16 to 6.18 show bus timings for a 16-bit 3-state access space in the H8S/2218 Group. When a 16-bit access space is accessed, the upper half (D15 to D8) of the data bus is used for the even address, and the lower half (D7 to D0) for the odd address.

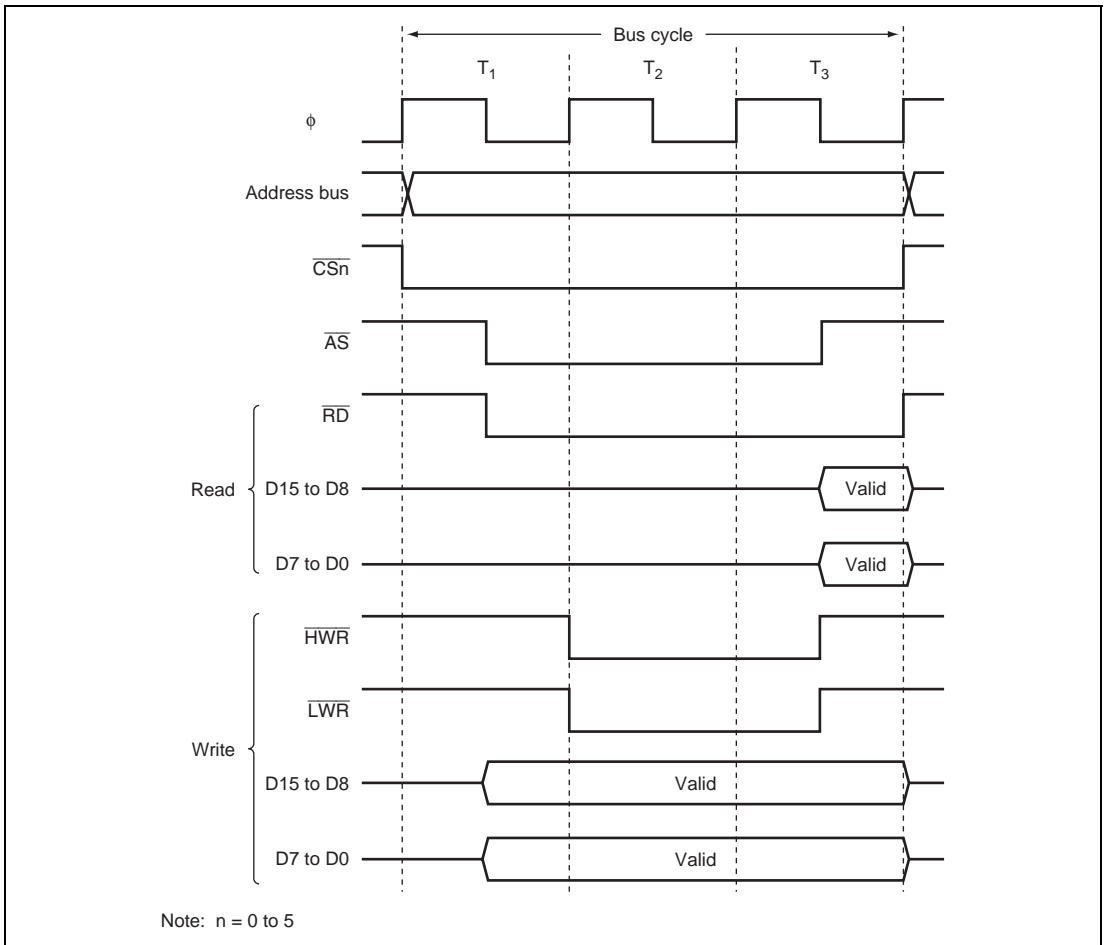
Wait states can be inserted.



**Figure 6.16 Bus Timing for 16-Bit 3-State Access Space (1) (Even Address Byte Access)**



**Figure 6.17 Bus Timing for 16-Bit 3-State Access Space (2) (Odd Address Byte Access)**



**Figure 6.18 Bus Timing for 16-Bit 3-State Access Space (3) (Word Access)**



#### 6.6.4 Wait Control

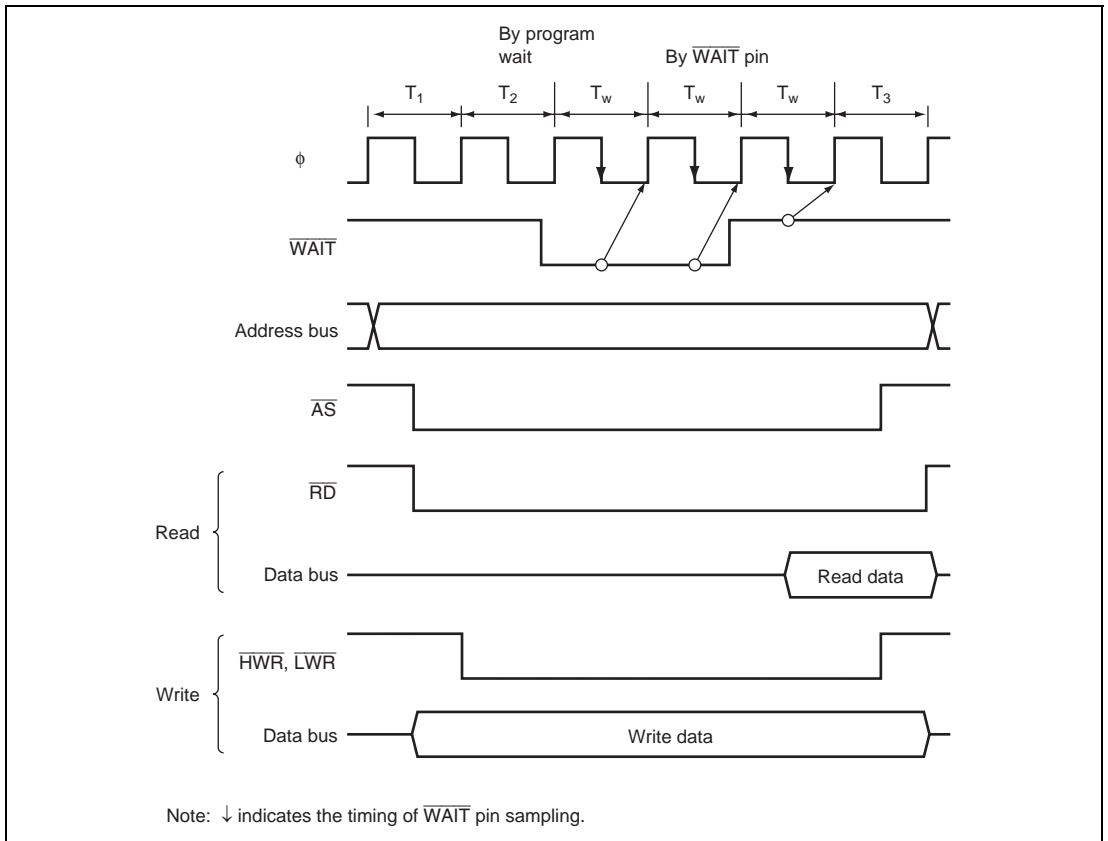
When accessing external space, this LSI can extend the bus cycle by inserting one or more wait states ( $T_w$ ). There are two ways of inserting wait states: program wait insertion and pin wait insertion using the  $\overline{\text{WAIT}}$  pin.

**Program Wait Insertion:** From 0 to 3 wait states can be inserted automatically between the  $T_2$  state and  $T_3$  state on an individual area basis in 3-state access space, according to the settings of WCRH and WCRL.

**Pin Wait Insertion:** Setting the WAITE bit in BCRH to 1 enables wait insertion by means of the  $\overline{\text{WAIT}}$  pin in the H8S/2218 Group. When external space is accessed in this state, program wait insertion is first carried out according to the settings in WCRH and WCRL. Then, if the  $\overline{\text{WAIT}}$  pin is low at the falling edge of  $\phi$  in the last  $T_2$  or  $T_w$  state, a  $T_w$  state is inserted. If the  $\overline{\text{WAIT}}$  pin is held low,  $T_w$  states are inserted until it goes high.

Figure 6.19 shows an example of wait state insertion timing.

In the H8S/2212 Group, the WAITE bit in BCRH should not be set to 1.



**Figure 6.19 Example of Wait State Insertion Timing**

## 6.7 Burst ROM Interface

With the H8S/2218 Group, external space area 0 can be designated as burst ROM space, and burst ROM interfacing can be performed. The burst ROM space interface enables 16-bit configuration ROM with burst access capability to be accessed at high speed.

Area 0 can be designated as burst ROM space by means of the BRSTRM bit in BCRH.

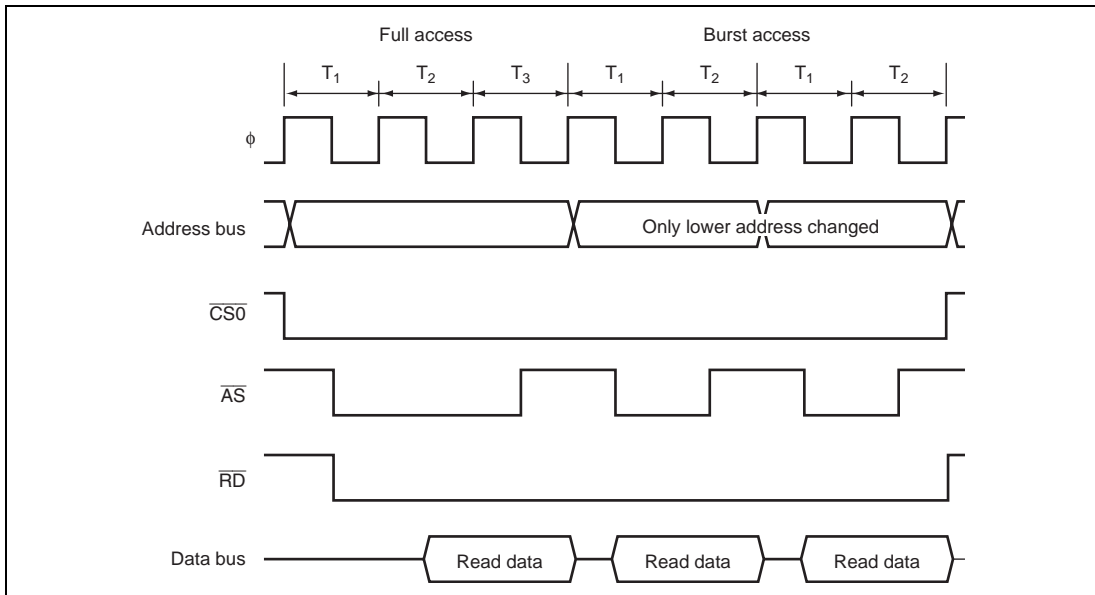
Consecutive burst accesses of a maximum of 4 words or 8 words can be performed for CPU instruction fetches only. One or two states can be selected for burst access.

### 6.7.1 Basic Timing

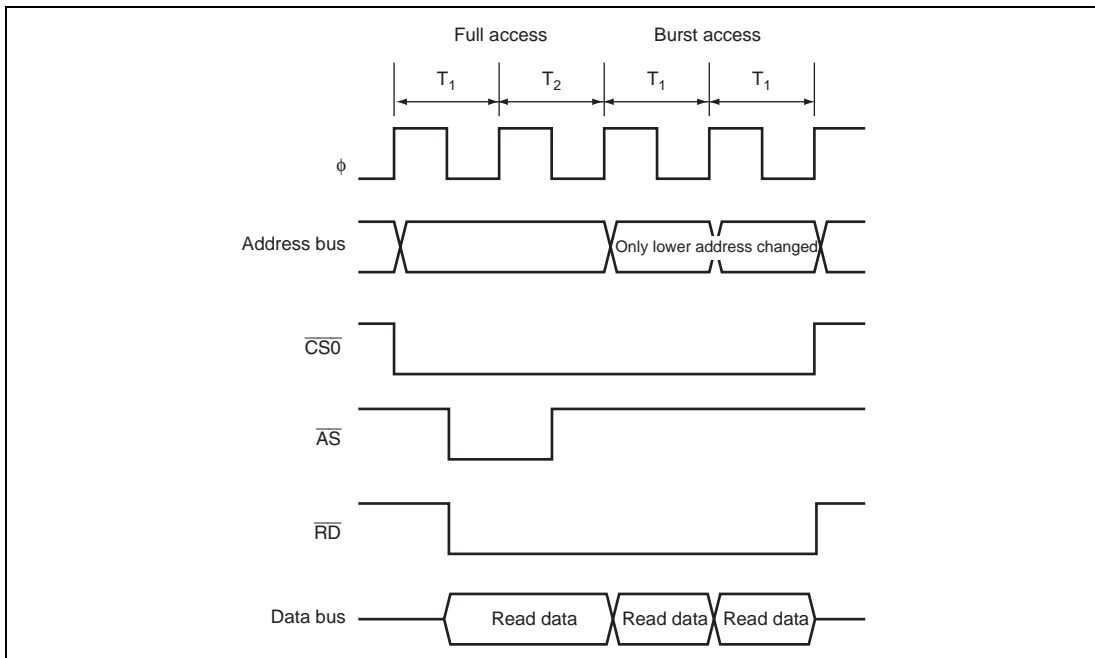
The number of states in the initial cycle (full access) of the burst ROM interface is in accordance with the setting of the AST0 bit in ASTCR. Also, when the AST0 bit is set to 1, wait state insertion is possible. One or two states can be selected for the burst cycle, according to the setting of the BRSTS1 bit in BCRH. Wait states cannot be inserted. When area 0 is designated as burst ROM space, it becomes 16-bit access space regardless of the setting of the ABW0 bit in ABWCR.

When the BRSTS0 bit in BCRH is cleared to 0, burst access of up to 4 words is performed; when the BRSTS0 bit is set to 1, burst access of up to 8 words is performed.

The basic access timing for burst ROM space is shown in figures 6.20 and 6.21. The timing shown in figure 6.20 is for the case where the AST0 and BRSTS1 bits are both set to 1, and that in figure 6.21 is for the case where both these bits are cleared to 0.



**Figure 6.20 Example of Burst ROM Access Timing (When  $AST0 = BRSTS1 = 1$ )**



**Figure 6.21 Example of Burst ROM Access Timing (When  $AST0 = BRSTS1 = 0$ )**

### 6.7.2 Wait Control

As with the basic bus interface, either program wait insertion or pin wait insertion using the  $\overline{\text{WAIT}}$  pin can be used in the initial cycle (full access) of the burst ROM interface. See section 6.6.4, Wait Control.

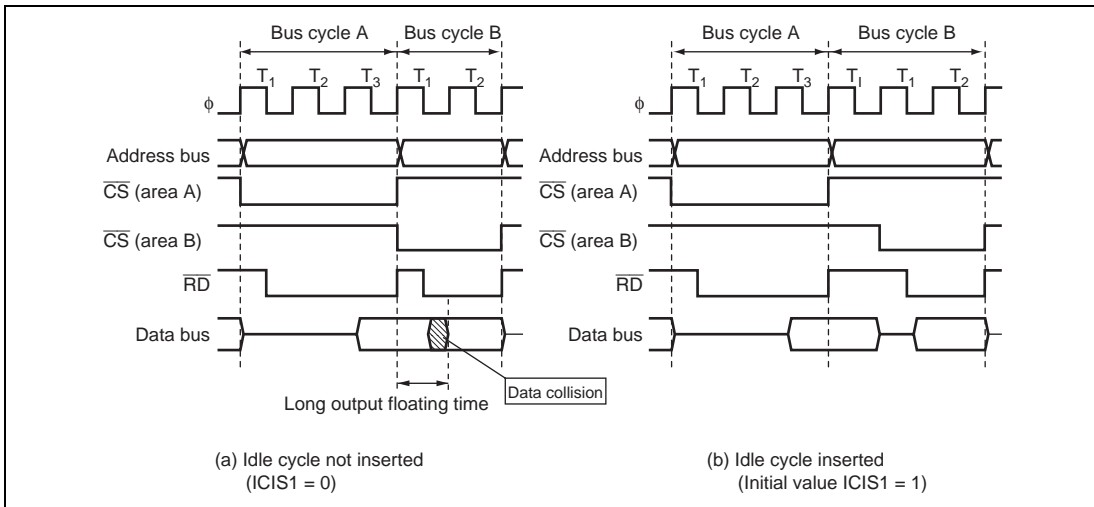
Wait states cannot be inserted in a burst cycle.

## 6.8 Idle Cycle

When the H8S/2218 Group accesses external space, it can insert a 1-state idle cycle ( $T_1$ ) between bus cycles in the following two cases: (1) when read accesses between different areas occur consecutively, and (2) when a write cycle occurs immediately after a read cycle. By inserting an idle cycle it is possible, for example, to avoid data collisions between ROM, with a long output floating time, and high-speed memory, I/O interfaces, and so on.

**Consecutive Reads between Different Areas:** If consecutive reads between different areas occur while the ICIS1 bit in BCRH is set to 1, an idle cycle is inserted at the start of the second read cycle.

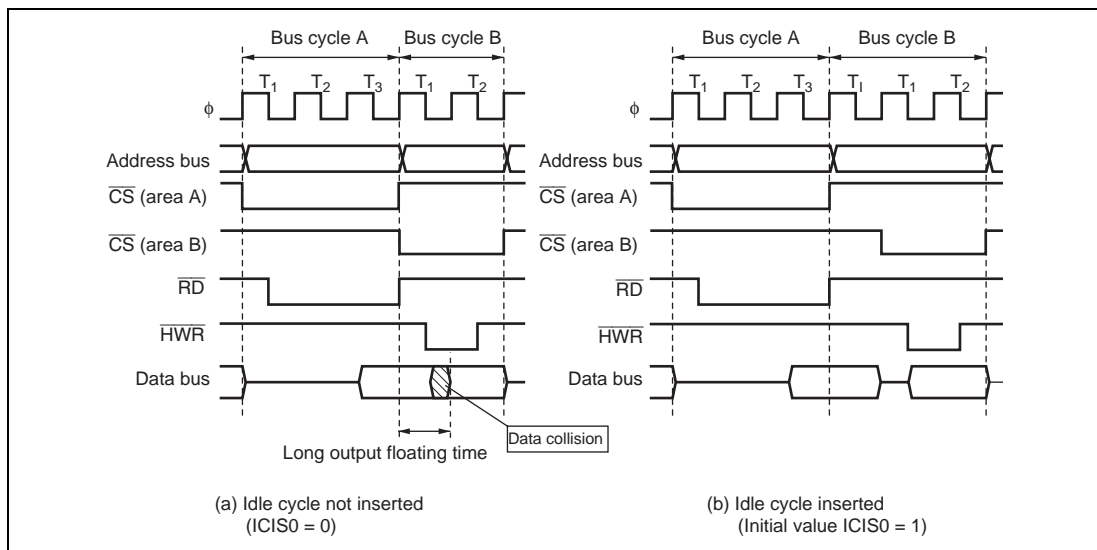
Figure 6.22 shows an example of the operation in this case. In this example, bus cycle A is a read cycle from ROM with a long output floating time, and bus cycle B is a read cycle from SRAM, each being located in a different area. In (a), an idle cycle is not inserted, and a collision occurs in cycle B between the read data from ROM and that from SRAM. In (b), an idle cycle is inserted, and a data collision is prevented.



**Figure 6.22 Example of Idle Cycle Operation (1)**

**Write after Read:** If an external write occurs after an external read while the ICIS0 bit in BCRH is set to 1, an idle cycle is inserted at the start of the write cycle.

Figure 6.23 shows an example of the operation in this case. In this example, bus cycle A is a read cycle from ROM with a long output floating time, and bus cycle B is a CPU write cycle. In (a), an idle cycle is not inserted, and a collision occurs in cycle B between the read data from ROM and the CPU write data. In (b), an idle cycle is inserted, and a data collision is prevented.



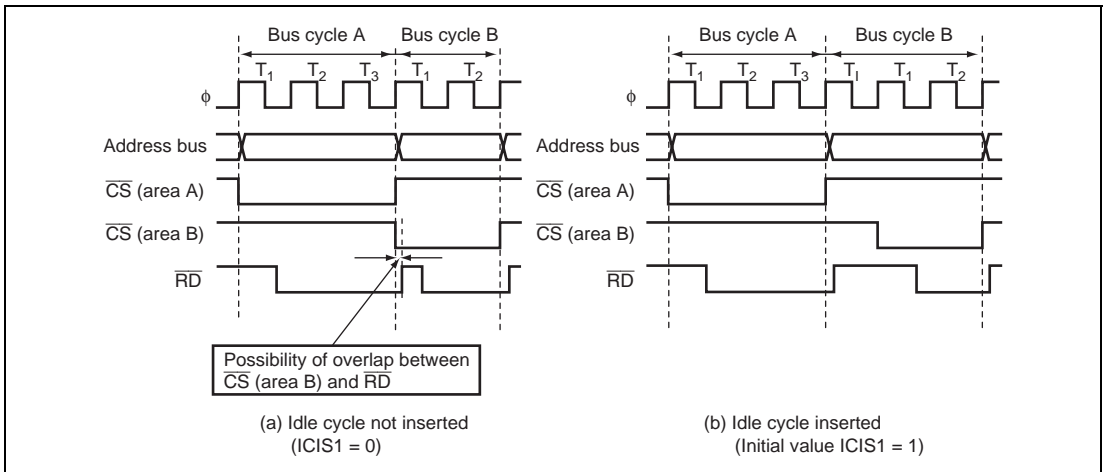
**Figure 6.23 Example of Idle Cycle Operation (2)**

**Relationship between Chip Select ( $\overline{CS}$ ) Signal and Read ( $\overline{RD}$ ) Signal:** Depending on the system's load conditions, the  $\overline{RD}$  signal may lag behind the  $\overline{CS}$  signal. An example is shown in figure 6.24.

In this case, with the setting for no idle cycle insertion (a), there may be a period of overlap between the bus cycle A  $\overline{RD}$  signal and the bus cycle B  $\overline{CS}$  signal.

Setting idle cycle insertion, as in (b), however, will prevent any overlap between the  $\overline{RD}$  and  $\overline{CS}$  signals.

In the initial state after reset release, idle cycle insertion (b) is set.



**Figure 6.24 Relationship between Chip Select ( $\overline{CS}$ ) and Read ( $\overline{RD}$ )**

Table 6.4 shows pin states in an idle cycle.

**Table 6.4 Pin States in Idle Cycle**

Pins	Pin State
A23 to A0	Contents of next bus cycle
D15 to D0	High impedance
$\overline{CS}_n$	High
$\overline{AS}$	High
$\overline{RD}$	High
$\overline{HWR}$	High
$\overline{LWR}$	High



## 6.9 Bus Release

The H8S/2218 Group can release the external bus in response to a bus request from an external device. In the external bus released state, the internal bus master continues to operate as long as there is no external access.

In external extended mode, the bus can be released to an external device by setting the BRLE bit in BCRL to 1. Driving the  $\overline{\text{BREQ}}$  pin low issues an external bus request to this LSI. When the  $\overline{\text{BREQ}}$  pin is sampled, at the prescribed timing the  $\overline{\text{BACK}}$  pin is driven low, and the address bus, data bus, and bus control signals are placed in the high-impedance state, establishing the external bus-released state.

In the external bus released state, an internal bus master can perform accesses using the internal bus. When an internal bus master wants to make an external access, it temporarily defers activation of the bus cycle, and waits for the bus request from the external bus master to be dropped.

When the  $\overline{\text{BREQ}}$  pin is driven high, the  $\overline{\text{BACK}}$  pin is driven high at the prescribed timing and the external bus released state is terminated.

In the event of simultaneous external bus release request and external access request generation, the order of priority is as follows:

(High) External bus release > Internal bus master external access (Low)

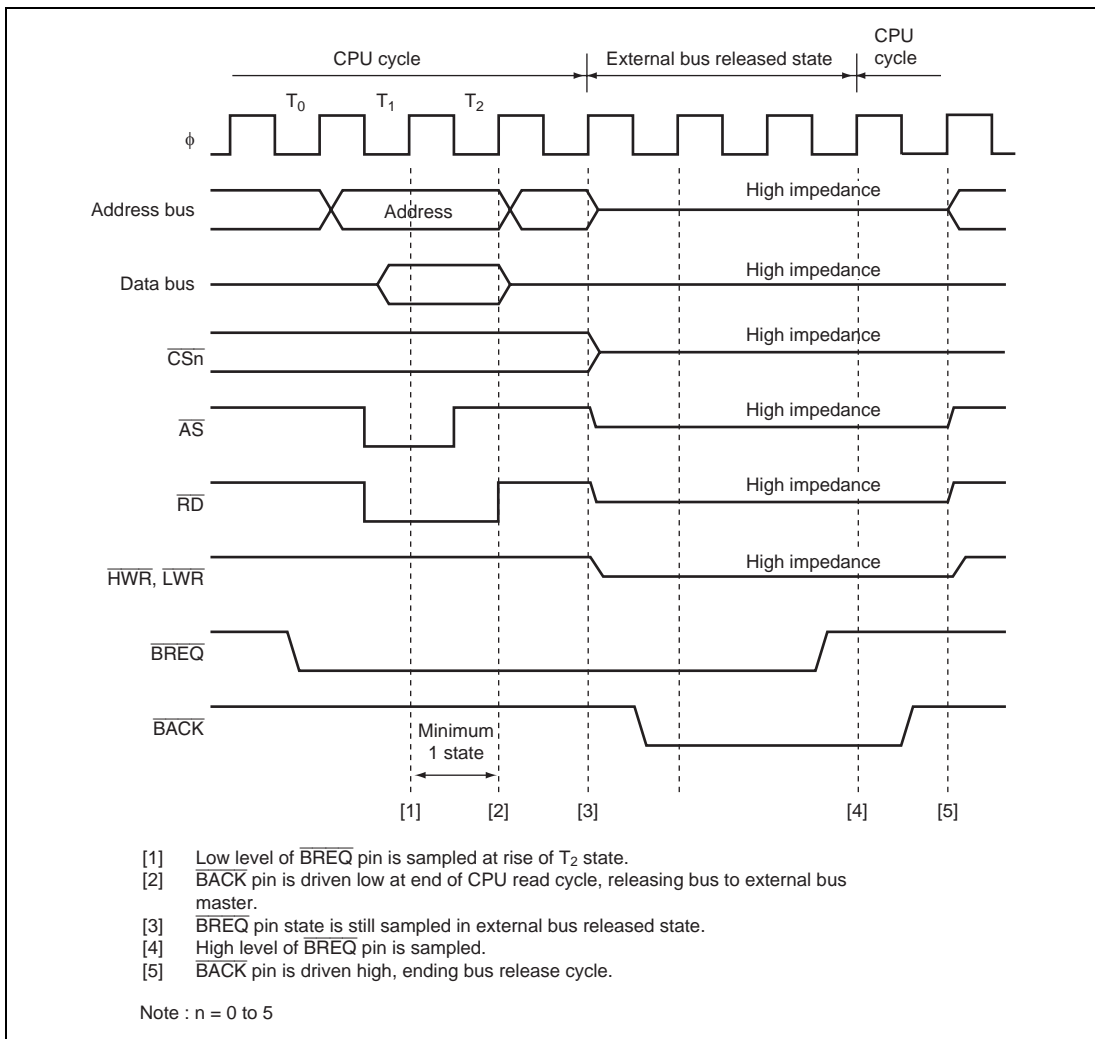
Table 6.5 shows pin states in the external bus released state.

In the H8S/2212 Group, the BRLE bit in BCRL should not be set to 1.

**Table 6.5 Pin States in Bus Released State**

Pins	Pin State
A23 to A0	High impedance
D15 to D0	High impedance
$\overline{\text{CSn}}$	High impedance
$\overline{\text{AS}}$	High impedance
$\overline{\text{RD}}$	High impedance
$\overline{\text{HWR}}$	High impedance
$\overline{\text{LWR}}$	High impedance

Figure 6.25 shows the timing for transition to the bus-released state.



**Figure 6.25 Bus-Released State Transition Timing**

### 6.9.1 Bus Release Usage Note

When MSTPCR is set to H'FFFFFF and transmitted to sleep mode, the external bus release does not function. To activate the external bus release in sleep mode, do not set MSTPCR to H'FFFFFF.

## 6.10 Bus Arbitration

This LSI has a bus arbiter that arbitrates bus master operations.

There are two bus masters, the CPU and DMAC, which perform read/write operations when they have possession of the bus. Each bus master requests the bus by means of a bus request signal. The bus arbiter determines priorities at the prescribed timing, and permits use of the bus by means of a bus request acknowledge signal. The selected bus master then takes possession of the bus and begins its operation.

### 6.10.1 Operation

The bus arbiter detects the bus masters' bus request signals, and if the bus is requested, sends a bus request acknowledge signal to the bus master making the request. If there are bus requests from more than one bus master, the bus request acknowledge signal is sent to the one with the highest priority. When a bus master receives the bus request acknowledge signal, it takes possession of the bus until that signal is canceled.

The order of priority of the bus masters is as follows:

(High) DMAC > CPU (Low)

An internal bus access by an internal bus master, and external bus release, can be executed in parallel in the H8S/2218 Group.

In the event of simultaneous external bus release request, and internal bus master external access request generation, the order of priority is as follows:

(High) External bus release > Internal bus master external access (Low)

The H8S/2212 Group does not have the external bus release function.

### 6.10.2 Bus Transfer Timing

Even if a bus request is received from a bus master with a higher priority than that of the bus master that has acquired the bus and is currently operating, the bus is not necessarily transferred immediately. There are specific times at which each bus master can relinquish the bus.

**CPU:** The CPU is the lowest-priority bus master, and if a bus request is received from the DMAC, the bus arbiter transfers the bus to the bus master that issued the request. The timing for transfer of the bus is as follows:

- The bus is transferred at a break between bus cycles. However, if a bus cycle is executed in discrete operations, as in the case of a longword-size access, the bus is not transferred between the operations.
- If the CPU is in sleep mode, it transfers the bus immediately.

**DMAC:** The DMAC sends the bus arbiter a request for the bus when an activation request is generated.

In the case of a USB request in short address mode or normal mode, and in cycle steal mode, the DMAC releases the bus after a single transfer.

In block transfer mode, it releases the bus after transfer of one block, and in burst mode, after completion of the transfer.

### 6.10.3 External Bus Release Usage Note

External bus release can be performed on completion of an external bus cycle in the H8S/2218 Group. The  $\overline{CS}$  signal remains low until the end of the external bus cycle. Therefore, when external bus release is performed, the  $\overline{CS}$  signal may change from the low level to the high-impedance state.

## 6.11 Resets and the Bus Controller

In a power-on reset, this LSI, including the bus controller, enters the reset state at that point, and an executing bus cycle is discontinued.

In a manual reset\*, the bus controller's registers and internal state are maintained, and an executing external bus cycle is completed. In this case,  $\overline{WAIT}$  input is ignored and write data is not guaranteed.

Note: \* Supported only by the H8S/2218 Group.

## Section 7 DMA Controller (DMAC)

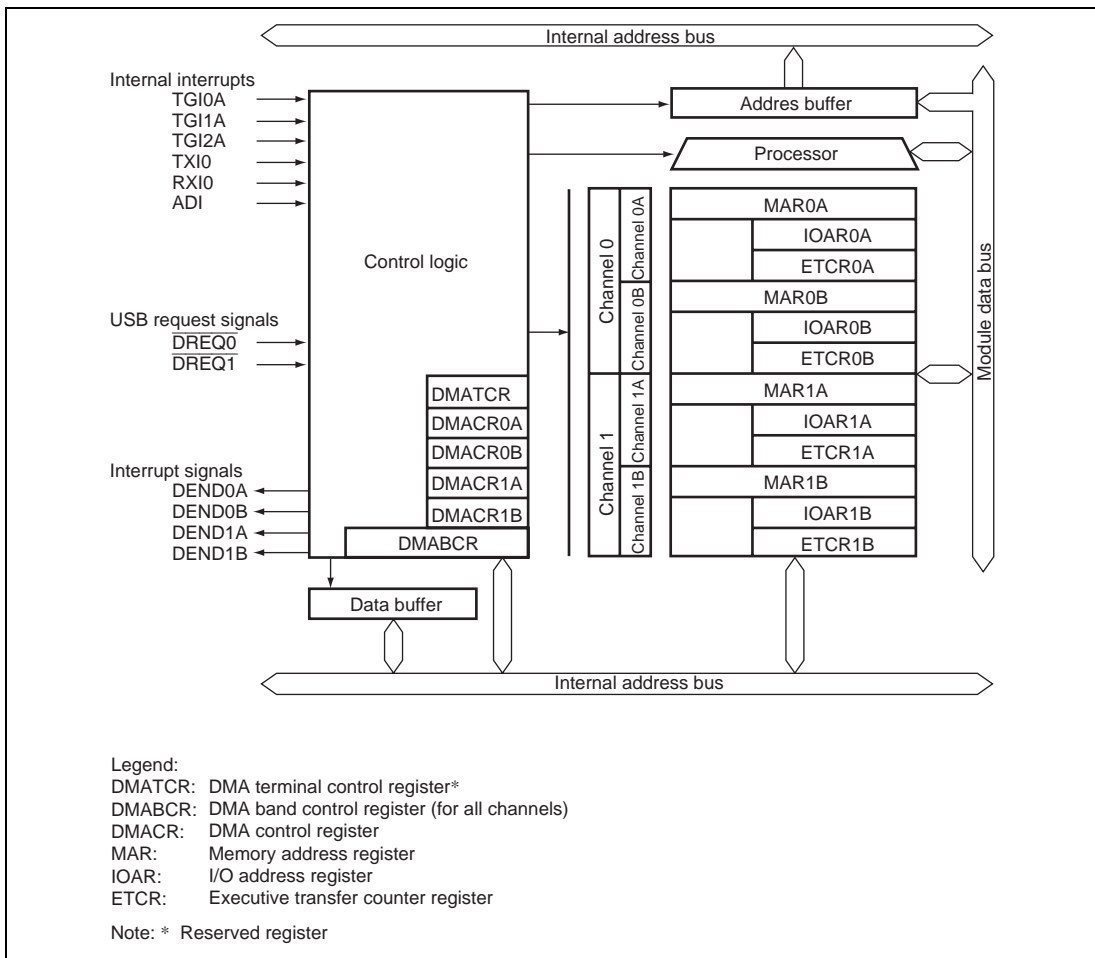
This LSI has a built-in DMA controller (DMAC) which can carry out data transfer on up to 4 channels.

### 7.1 Features

The features of the DMAC are listed below.

- Choice of short address mode or full address mode
  - (1) Short address mode
    - Maximum of 4 channels can be used
    - Choice of dual address mode
    - In dual address mode, one of the two addresses, transfer source and transfer destination, is specified as 24 bits and the other as 16 bits
    - Choice of sequential mode, idle mode, or repeat mode for dual address mode
  - (2) Full address mode
    - Maximum of 2 channels can be used
    - Transfer source and transfer destination address specified as 24 bits
    - Choice of normal mode or block transfer mode
- 16-Mbyte address space can be specified directly
- Byte or word can be set as the transfer unit
- Activation sources: internal interrupt, USB request, auto-request (depending on transfer mode)
  - 16-bit timer-pulse unit (TPU) compare match/input capture interrupts
  - Serial communication interface (SCI\_0) transmission complete interrupt, reception complete interrupt
  - A/D conversion end Interrupt
  - USB request
  - Auto-request
- Module stop mode can be set

A block diagram of the DMAC is shown in figure 7.1.



**Figure 7.1 Block Diagram of DMAC**

## 7.2 Register Configuration

The DMAC registers are listed below.

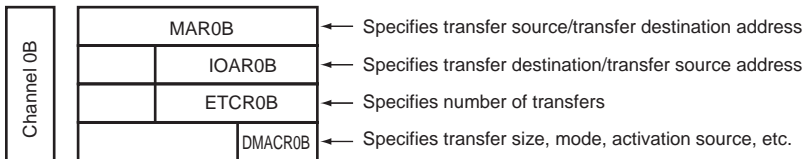
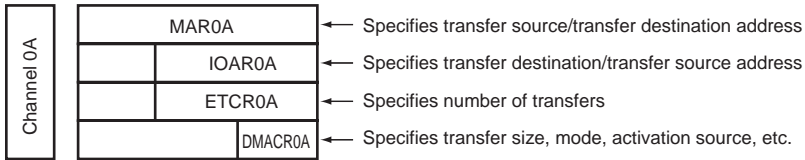
- Memory address register 0A (MAR0A)
- I/O address register 0A (IOAR0A)
- Transfer count register 0A (ETCR0A)
- Memory address register 0B (MAR0B)
- I/O address register 0B (IOAR0B)
- Transfer count register 0B (ETCR0B)
- Memory address register 1A (MAR1A)
- I/O address register 1A (IOAR1A)
- Transfer count register 1A (ETCR1A)
- Memory address register 1B (MAR1B)
- I/O address register 1B (IOAR1B)
- Transfer count register 1B (ETCR1B)
- DMA control register 0A (DMACR0A)
- DMA control register 0B (DMACR0B)
- DMA control register 1A (DMACR1A)
- DMA control register 1B (DMACR1B)
- DMA band control register (DMABCR)

The DMAC register functions differs depending on the address modes: short address mode and full address mode. The DMAC register functions are described in each address mode. Short address mode or full address mode can be selected for channels 1 and 0 independently by means of bits FAE1 and FAE0.

**Table 7.1 Short Address Mode and Full Address Mode (For 1 Channel: Example of Channel 0)****FAE0 Description**

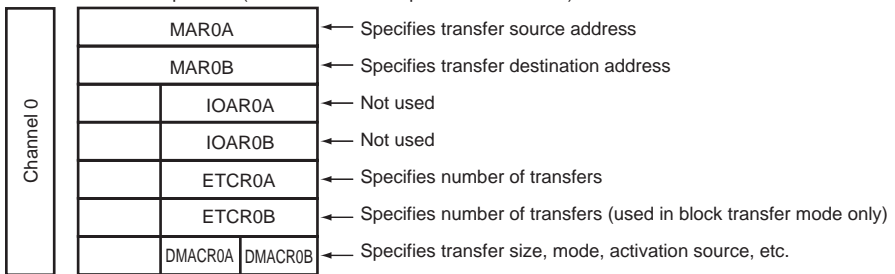
0

Short address mode specified (channels A and B operate independently)



1

Full address mode specified (channels A and B operate combination)





## 7.3 Register Descriptions

### 7.3.1 Memory Address Registers (MAR)

- Short Address Mode

MAR is a 32-bit readable/writable register that specifies the transfer source address or destination address. The upper 8 bits of MAR are reserved: they are always read as 0, and cannot be modified. Whether MAR functions as the source address register or as the destination address register can be selected by means of the DTDIR bit in DMACR.

MAR is incremented or decremented each time a byte or word transfer is executed, so that the address specified by MAR is constantly updated. For details, see section 7.3.4, DMA Control Register (DMACR). MAR is not initialized by a reset or in standby mode.

- Full Address Mode

MAR is a 32-bit readable/writable register; MARA functions as the transfer source address register, and MARB as the destination address register.

MAR is composed of two 16-bit registers, MARH and MARL. The upper 8 bits of MARH are reserved: they are always read as 0, and cannot be modified. MAR is incremented or decremented each time a byte or word transfer is executed, so that the source or destination memory address can be updated automatically. For details, see section 7.3.4, DMA Control Register (DMACR). MAR is not initialized by a reset or in standby mode.

### 7.3.2 I/O Address Register (IOAR)

- Short Address Mode

IOAR is a 16-bit readable/writable register that specifies the lower 16 bits of the transfer source address or destination address. The upper 8 bits of the transfer address are automatically set to H'FF. Whether IOAR functions as the source address register or as the destination address register can be selected by means of the DTDIR bit in DMACR.

IOAR is not incremented or decremented each time a transfer is executed, so that the address specified by IOAR is fixed. IOAR is not initialized by a reset or in standby mode.

- Full Address Mode:

IOAR is not used in full address mode transfer.

### 7.3.3 Execute Transfer Count Register (ETCR)

- Short Address Mode

ETCR is a 16-bit readable/writable register that specifies the number of transfers. The setting of this register is different for sequential mode and idle mode on the one hand, and for repeat mode on the other. ETCR is not initialized by a reset or in standby mode.

- Sequential Mode and Idle Mode

In sequential mode and idle mode, ETCR functions as a 16-bit transfer counter (with a count range of 1 to 65,536). ETCR is decremented by 1 each time a transfer is performed, and when the count reaches H'0000, the DTE bit in DMABCR is cleared, and transfer ends.

- Repeat Mode

In repeat mode, ETCR functions as an 8-bit transfer counter ETCRL (with a count range of 1 to 256) and transfer number storage register ETCRH. ETCRL is decremented by 1 each time a transfer is performed, and when the count reaches H'00, ETCRL is loaded with the value in ETCRH. At this point, MAR is automatically restored to the value it had when the count was started. The DTE bit in DMABCR is not cleared, and so transfers can be performed repeatedly until the DTE bit is cleared by the user.

- Full Address Mode

ETCR is a 16-bit readable/writable register that specifies the number of transfers. The function of this register is different in normal mode and in block transfer mode. ETCR is not initialized by a reset or in standby mode.

- Normal Mode

- (a) ETCRA

In normal mode, ETCRA functions as a 16-bit transfer counter. ETCRA is decremented by 1 each time a transfer is performed, and transfer ends when the count reaches H'0000.

- (b) ETCRB

ETCRB is not used in normal mode.

- Block Transfer Mode

- (a) ETCRA

In block transfer mode, ETCRAL functions as an 8-bit block size counter and ETCRAH holds the block size. ETCRAL is decremented each time a 1-byte or 1-word transfer is performed, and when the count reaches H'00, ETCRAL is loaded with the value in ETCRAH. So by setting the block size in ETCRAH and ETCRAL, it is possible to repeatedly transfer blocks consisting of any desired number of bytes or words.

- (b) ETCRB

ETCRB functions in block transfer mode, as a 16-bit block transfer counter. ETCRB is decremented by 1 each time a block is transferred, and transfer ends when the count reaches H'0000.

### 7.3.4 DMA Control Register (DMACR)

DMACR controls the operation of each DMAC channel.

- Short Address Mode (common to DMACRA and DMACRB)

Bit	Bit Name	Initial Value	R/W	Description
7	DTSZ	0	R/W	<p>Data Transfer Size</p> <p>Selects the size of data to be transferred at one time.</p> <p>0: Byte-size transfer</p> <p>1: Word-size transfer</p>
6	DTID	0	R/W	<p>Data Transfer Increment/Decrement</p> <p>Selects incrementing or decrementing of MAR every data transfer in sequential mode or repeat mode.</p> <p>In idle mode, MAR is neither incremented nor decremented.</p> <p>0: MAR is incremented after a data transfer</p> <ul style="list-style-type: none"> <li>• When DTSZ = 0, MAR is incremented by 1 after a transfer</li> <li>• When DTSZ = 1, MAR is incremented by 2 after a transfer</li> </ul> <p>1: MAR is decremented after a data transfer</p> <ul style="list-style-type: none"> <li>• When DTSZ = 0, MAR is decremented by 1 after a transfer</li> <li>• When DTSZ = 1, MAR is decremented by 2 after a transfer</li> </ul>

Bit	Bit Name	Initial Value	R/W	Description												
5	RPE	0	R/W	<p>Repeat Enable</p> <p>Used in combination with the DTIE bit in DMABCR to select the mode (sequential, idle, or repeat) in which transfer is to be performed.</p> <p>RPE DTIE</p> <table> <tr> <td>0</td> <td>0:</td> <td>Transfer in sequential mode (no transfer end interrupt)</td> </tr> <tr> <td>0</td> <td>1:</td> <td>Transfer in sequential mode (with transfer end interrupt)</td> </tr> <tr> <td>1</td> <td>0:</td> <td>Transfer in repeat mode (no transfer end interrupt)</td> </tr> <tr> <td>1</td> <td>1:</td> <td>Transfer in idle mode (with transfer end interrupt)</td> </tr> </table> <p>Note: For details of operation in sequential, idle, and repeat mode, see section 7.4.2, Sequential Mode, section 7.4.3, Idle Mode, and section 7.4.4, Repeat Mode.</p>	0	0:	Transfer in sequential mode (no transfer end interrupt)	0	1:	Transfer in sequential mode (with transfer end interrupt)	1	0:	Transfer in repeat mode (no transfer end interrupt)	1	1:	Transfer in idle mode (with transfer end interrupt)
0	0:	Transfer in sequential mode (no transfer end interrupt)														
0	1:	Transfer in sequential mode (with transfer end interrupt)														
1	0:	Transfer in repeat mode (no transfer end interrupt)														
1	1:	Transfer in idle mode (with transfer end interrupt)														
4	DTDIR	0	R/W	<p>Data Transfer Direction</p> <p>Specifies the data transfer direction (source or destination).</p> <p>0: Transfer with MAR as source address and IOAR as destination address</p> <p>1: Transfer with IOAR as source address and MAR as destination address</p>												

Bit	Bit Name	Initial Value	R/W	Description
3	DTF3	0	R/W	Data Transfer Factor
2	DTF2	0	R/W	These bits select the data transfer factor (activation source).
1	DTF1	0	R/W	0000: —
0	DTF0	0	R/W	0001: Activated by A/D conversion end interrupt 0010: — 0011: — 0100: Activated by SCI channel 0 transmission complete interrupt 0101: Activated by SCI channel 0 reception complete interrupt 0110: — 0111: — 1000: Activated by TPU channel 0 compare match/input capture A interrupt 1001: Activated by TPU channel 1 compare match/input capture A interrupt 1010: Activated by TPU channel 2 compare match/input capture A interrupt 1011: — 1100: — 1101: — 1110: — 1111: —

The same factor can be selected for more than one channel. In this case, activation starts with the highest-priority channel according to the relative channel priorities. For relative channel priorities, see section 7.4.10, DMAC Multi-Channel Operation.

- Full Address Mode (DMACRA)

Bit	Bit Name	Initial Value	R/W	Description
15	DTSZ	0	R/W	Data Transfer Size Selects the size of data to be transferred at one time. 0: Byte-size transfer 1: Word-size transfer
14	SAID	0	R/W	Source Address Increment/Decrement
13	SAIDE	0	R/W	Source Address Increment/Decrement Enable These bits specify whether source address register MARA is to be incremented, decremented, or left unchanged, when data transfer is performed. 00: MARA is fixed 01: MARA is incremented after a data transfer <ul style="list-style-type: none"> <li>When DTSZ = 0, MARA is incremented by 1 after a transfer</li> <li>When DTSZ = 1, MARA is incremented by 2 after a transfer</li> </ul> 10: MARA is fixed 11: MARA is decremented after a data transfer <ul style="list-style-type: none"> <li>When DTSZ = 0, MARA is decremented by 1 after a transfer</li> <li>When DTSZ = 1, MARA is decremented by 2 after a transfer</li> </ul>
12	BLKDIR	0	R/W	Block Direction
11	BLKE	0	R/W	Block Enable These bits specify whether normal mode or block transfer mode is to be used. If block transfer mode is specified, the BLKDIR bit specifies whether the source side or the destination side is to be the block area. 00: Transfer in normal mode 01: Transfer in block transfer mode, destination side is block area 10: Transfer in normal mode 11: Transfer in block transfer mode, source side is block area For operation in normal mode and block transfer mode, see section 7.4, Operation.

Bit	Bit Name	Initial Value	R/W	Description
10 to 8	—	All 0	R/W	Reserved Although these bits are readable/writable, only 0 should be written to.

- Full Address Mode (DMACRB)

Bit	Bit Name	Initial Value	R/W	Description
7	—	0	R/W	Reserved Although this bit is readable/writable, only 0 should be written to.
6	DAID	0	R/W	Destination Address Increment/Decrement
5	DAIDE	0	R/W	Destination Address Increment/Decrement Enable These bits specify whether destination address register MARB is to be incremented, decremented, or left unchanged, when data transfer is performed. 00: MARB is fixed 01: MARB is incremented after a data transfer <ul style="list-style-type: none"> <li>When DTSZ = 0, MARB is incremented by 1 after a transfer</li> <li>When DTSZ = 1, MARB is incremented by 2 after a transfer</li> </ul> 10: MARB is fixed 11: MARB is decremented after a data transfer <ul style="list-style-type: none"> <li>When DTSZ = 0, MARB is decremented by 1 after a transfer</li> <li>When DTSZ = 1, MARB is decremented by 2 after a transfer</li> </ul>
4	—	0	R/W	Reserved Although this bit is readable/writable, only 0 should be written to.

Bit	Bit Name	Initial Value	R/W	Description
3	DTF3	0	R/W	Data Transfer Factor
2	DTF2	0	R/W	These bits select the data transfer factor (activation source).
1	DTF1	0	R/W	In normal mode:
0	DTF0	0	R/W	0000: — 0001: — 0010: — 0011: Activated by $\overline{\text{DREQ}}$ signal's low level input from USB (USB request) 010x: — 0110: Auto-request (cycle steal) 0111: Auto-request (burst) 1xxx: —
				In block transfer mode:
				0000: — 0001: Activated by A/D conversion end interrupt 0010: — 0011: — 0100: Activated by SCI channel 0 transmission complete interrupt 0101: Activated by SCI channel 0 reception complete interrupt 0110: — 0111: — 1000: Activated by TPU channel 0 compare match/input capture A interrupt 1001: Activated by TPU channel 1 compare match/input capture A interrupt 1010: Activated by TPU channel 2 compare match/input capture A interrupt 1011: — 11xx: —
				The same factor can be selected for more than one channel. In this case, activation starts with the highest-priority channel according to the relative channel priorities. For relative channel priorities, see section 7.4.10, DMAC Multi-Channel Operation.
				Legend:
				x: Don't care



### 7.3.5 DMA Band Control Register (DMABCR)

DMABCR controls the operation of each DMAC channel.

- Short Address Mode

Bit	Bit Name	Initial Value	R/W	Description
15	FAE1	0	R/W	Full Address Enable 1 Specifies whether channel 1 is to be used in short address mode or full address mode. In short address mode, channels 1A and 1B are used as independent channels. 0: Short address mode 1: Full address mode
14	FAE0	0	R/W	Full Address Enable 0 Specifies whether channel 0 is to be used in short address mode or full address mode. In short address mode, channels 0A and 0B are used as independent channels. 0: Short address mode 1: Full address mode
13, 12	—	—	R/W	Reserved The write value should always be 0.

Bit	Bit Name	Initial Value	R/W	Description
11	DTA1B	0	R/W	Data Transfer Acknowledge
10	DTA1A	0	R/W	These bits enable or disable clearing, when DMA transfer is performed, of the internal interrupt source selected by the data transfer factor setting.
9	DTA0B	0	R/W	When DTE = 1 and DTA = 1, the internal interrupt source selected by the data transfer factor setting is cleared automatically by DMA transfer. When DTE = 1 and DTA = 1, the internal interrupt source selected by the data transfer factor setting does not issue an interrupt request to the CPU.
8	DTA0A	0	R/W	When DTE = 1 and DTA = 0, the internal interrupt source selected by the data transfer factor setting is not cleared when a transfer is performed, and can issue an interrupt request to the CPU in parallel. In this case, the interrupt source should be cleared by the CPU. When DTE = 0, the internal interrupt source selected by the data transfer factor setting issues an interrupt request to the CPU regardless of the DTA bit setting. 0: Clearing of selected internal interrupt source at time of DMA transfer is disabled 1: Clearing of selected internal interrupt source at time of DMA transfer is enabled

Bit	Bit Name	Initial Value	R/W	Description
7	DTE1B	0	R/W	Data Transfer Enable
6	DTE1A	0	R/W	When DTE = 0, data transfer is disabled and the activation source selected by the data transfer factor setting is ignored. If the activation source is an internal interrupt, an interrupt request is issued to the CPU. If the DTIE bit is set to 1 when DTE = 0, the DMAC regards this as indicating the end of a transfer, and issues a transfer end interrupt request to the CPU.  The conditions for the DTE bit being cleared to 0 are as follows: <ul style="list-style-type: none"> <li>• When initialization is performed</li> <li>• When the specified number of transfers have been completed in a transfer mode other than repeat mode</li> <li>• When 0 is written to the DTE bit to forcibly abort the transfer, or for a similar reason</li> </ul> When DTE = 1, data transfer is enabled and the DMAC waits for a request by the activation source selected by the data transfer factor setting. When a request is issued by the activation source, DMA transfer is executed. The condition for the DTE bit being set to 1 is as follows: <ul style="list-style-type: none"> <li>• When 1 is written to the DTE bit after the DTE bit is read as 0</li> </ul> 0: Data transfer disabled 1: Data transfer enabled
5	DTE0B	0	R/W	
4	DTE0A	0	R/W	
<hr/>				
3	DTIE1B	0	R/W	Data Transfer End Interrupt Enable
2	DTIE1A	0	R/W	These bits enable or disable an interrupt to the CPU when transfer ends. If the DTIE bit is set to 1 when DTE = 0, the DMAC regards this as indicating the end of a transfer, and issues a transfer end interrupt request to the CPU.  A transfer end interrupt can be canceled either by clearing the DTIE bit to 0 in the interrupt handling routine, or by performing processing to continue transfer by setting the transfer counter and address register again, and then setting the DTE bit to 1.  0: Transfer end interrupt disabled 1: Transfer end interrupt enabled
1	DTIE0B	0	R/W	
0	DTIE0A	0	R/W	
<hr/>				

## • Full Address Mode

Bit	Bit Name	Initial Value	R/W	Description
15	FAE1	0	R/W	Full Address Enable 1 Specifies whether channel 1 is to be used in short address mode or full address mode. In full address mode, channels 1A and 1B are used together as a single channel. 0: Short address mode 1: Full address mode
14	FAE0	0	R/W	Full Address Enable 0 Specifies whether channel 0 is to be used in short address mode or full address mode. In full address mode, channels 0A and 0B are used together as a single channel. 0: Short address mode 1: Full address mode
13,12	—	All 0	R/W	Reserved Although these bits are readable/writable, only 0 should be written to.

Bit	Bit Name	Initial Value	R/W	Description
				<p>Data Transfer Acknowledge</p> <p>Enables or disables clearing, when DMA transfer is performed, of the internal interrupt source selected by the data transfer factor setting.</p> <p>When DTE = 1 and DTA = 1, the internal interrupt source selected by the data transfer factor setting is cleared automatically by DMA transfer. When DTE = 1 and DTA = 1, the internal interrupt source selected by the data transfer factor setting does not issue an interrupt request to the CPU.</p> <p>When DTE = 1 and DTA = 0, the internal interrupt source selected by the data transfer factor setting is not cleared when a transfer is performed, and can issue an interrupt request to the CPU in parallel. In this case, the interrupt source should be cleared by the CPU transfer.</p> <p>When DTE = 0, the internal interrupt source selected by the data transfer factor setting issues an interrupt request to the CPU regardless of the DTA bit setting.</p> <p>The state of the DTME bit does not affect the above operations.</p>
11	DTA1	0	R/W	<p>Data transfer acknowledge 1</p> <p>Enables or disables clearing, when DMA transfer is performed, of the internal interrupt source selected by the channel 1 data transfer factor setting.</p> <p>0: Clearing of selected internal interrupt source at time of DMA transfer is disabled</p> <p>1: Clearing of selected internal interrupt source at time of DMA transfer is enabled</p>
10	–	0	R/W	<p>Reserved</p> <p>Although this bit is readable/writable, only 0 should be written to.</p>
9	DTA0	0	R/W	<p>Data Transfer Acknowledge 0</p> <p>Enables or disables clearing, when DMA transfer is performed, of the internal interrupt source selected by the channel 0 data transfer factor setting.</p> <p>0: Clearing of selected internal interrupt source at time of DMA transfer is disabled</p> <p>1: Clearing of selected internal interrupt source at time of DMA transfer is enabled</p>

Bit	Bit Name	Initial Value	R/W	Description
8	–	0	R/W	Reserved Although this bit is readable/writable, only 0 should be written to.
				<p>Data Transfer Master Enable</p> <p>Together with the DTE bit, this bit controls enabling or disabling of data transfer on the relevant channel. When both the DTME bit and the DTE bit are set to 1, transfer is enabled for the channel. If the relevant channel is in the middle of a burst mode transfer when an NMI interrupt is generated, the DTME bit is cleared, the transfer is interrupted, and bus mastership passes to the CPU. When the DTME bit is subsequently set to 1 again, the interrupted transfer is resumed. In block transfer mode, however, the DTME bit is not cleared by an NMI interrupt, and transfer is not interrupted.</p> <p>The conditions for the DTME bit being cleared to 0 are as follows:</p> <ul style="list-style-type: none"> <li>• When initialization is performed</li> <li>• When NMI is input in burst mode</li> <li>• When 0 is written to the DTME bit</li> </ul> <p>The condition for DTME being set to 1 is as follows:</p> <ul style="list-style-type: none"> <li>• When 1 is written to DTME after DTME is read as 0</li> </ul>
7	DTME1	0	R/W	<p>Data Transfer Master Enable 1</p> <p>Enables or disables data transfer on channel 1</p> <p>0: Data transfer disabled. In burst mode, cleared to 0 by an NMI interrupt</p> <p>1: Data transfer enabled</p>

Bit	Bit Name	Initial Value	R/W	Description
				<p>Data Transfer Enable</p> <p>When DTE = 0, data transfer is disabled and the activation source selected by the data transfer factor setting is ignored. If the activation source is an internal interrupt, an interrupt request is issued to the CPU. If the DTIE bit is set to 1 when DTE = 0, the DMAC regards this as indicating the end of a transfer, and issues a transfer end interrupt request to the CPU.</p> <p>The conditions for the DTE bit being cleared to 0 are as follows:</p> <ul style="list-style-type: none"> <li>• When initialization is performed</li> <li>• When the specified number of transfers have been completed</li> <li>• When 0 is written to the DTE bit to forcibly abort the transfer, or for a similar reason</li> </ul> <p>When DTE = 1 and DTME = 1, data transfer is enabled and the DMAC waits for a request by the activation source selected by the data transfer factor setting. When a request is issued by the activation source, DMA transfer is executed.</p> <p>The condition for the DTE bit being set to 1 is as follows:</p> <ul style="list-style-type: none"> <li>• When 1 is written to the DTE bit after the DTE bit is read as 0</li> </ul>
6	DTE1	0	R/W	<p>Data Transfer Enable 1</p> <p>Enables or disables data transfer on channel 1.</p> <p>0: Data transfer disabled</p> <p>1: Data transfer enabled</p>
5	DTME0	0	R/W	<p>Data Transfer Master Enable 0</p> <p>Enables or disables data transfer on channel 0.</p> <p>0: Data transfer disabled. In burst mode, cleared to 0 by an NMI interrupt</p> <p>1: Data transfer enabled</p>
4	DTE0	0	R/W	<p>Data Transfer Enable 0</p> <p>Enables or disables data transfer on channel 0.</p> <p>0: Data transfer disabled</p> <p>1: Data transfer enabled</p>

Bit	Bit Name	Initial Value	R/W	Description
				Data Transfer Interrupt Enable B Enables or disables an interrupt to the CPU when transfer is interrupted. If the DTIEB bit is set to 1 when DTME = 0, the DMAC regards this as indicating a break in the transfer, and issues a transfer break interrupt request to the CPU. A transfer break interrupt can be canceled either by clearing the DTIEB bit to 0 in the interrupt handling routine, or by performing processing to continue transfer by setting the DTME bit to 1.
3	DTIE1B	0	R/W	Data Transfer Interrupt Enable 1B Enables or disables the channel 1 transfer break interrupt. 0: Transfer break interrupt disabled 1: Transfer break interrupt enabled
				Data Transfer End Interrupt Enable A Enables or disables an interrupt to the CPU when transfer ends. If the DTIEA bit is set to 1 when DTE = 0, the DMAC regards this as indicating the end of a transfer, and issues a transfer end interrupt request to the CPU. A transfer end interrupt can be canceled either by clearing the DTIEA bit to 0 in the interrupt handling routine, or by performing processing to continue transfer by setting the DTE bit to 1.
2	DTIE1A	0	R/W	Data Transfer End Interrupt Enable 1A Enables or disables the channel 1 transfer end interrupt. 0: Transfer end interrupt disabled 1: Transfer end interrupt enabled
				Data Transfer Interrupt Enable 0B Enables or disables the channel 0 transfer break interrupt. 0: Transfer break interrupt disabled 1: Transfer break interrupt enabled
1	DTIE0B	0	R/W	Data Transfer Interrupt Enable 0B Enables or disables the channel 0 transfer break interrupt. 0: Transfer break interrupt disabled 1: Transfer break interrupt enabled
				Data Transfer End Interrupt Enable 0A Enables or disables the channel 0 transfer end interrupt. 0: Transfer end interrupt disabled 1: Transfer end interrupt enabled
0	DTIE0A	0	R/W	Data Transfer End Interrupt Enable 0A Enables or disables the channel 0 transfer end interrupt. 0: Transfer end interrupt disabled 1: Transfer end interrupt enabled



## 7.4 Operation

### 7.4.1 Transfer Modes

Table 7.2 lists the DMAC modes.

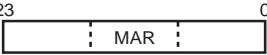
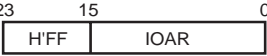

**Table 7.2 DMAC Transfer Modes**

Transfer Mode		Transfer Source	Remarks
Short address mode	Dual address mode	(1) Sequential mode (2) Idle mode (3) Repeat Mode	<ul style="list-style-type: none"> <li>• TPU channel 0 to 2 compare match/input capture A interrupt</li> <li>• SCI transmission complete interrupt</li> <li>• SCI reception complete interrupt</li> <li>• A/D conversion end interrupt</li> </ul>
Full address mode		(4) Normal mode	<ul style="list-style-type: none"> <li>• USB request</li> <li>• Auto-request</li> </ul>
		(5) Block transfer mode	<ul style="list-style-type: none"> <li>• TPU channel 0 to 2 compare match/input capture A interrupt</li> <li>• SCI transmission complete interrupt</li> <li>• SCI reception complete interrupt</li> <li>• A/D conversion end interrupt</li> </ul>

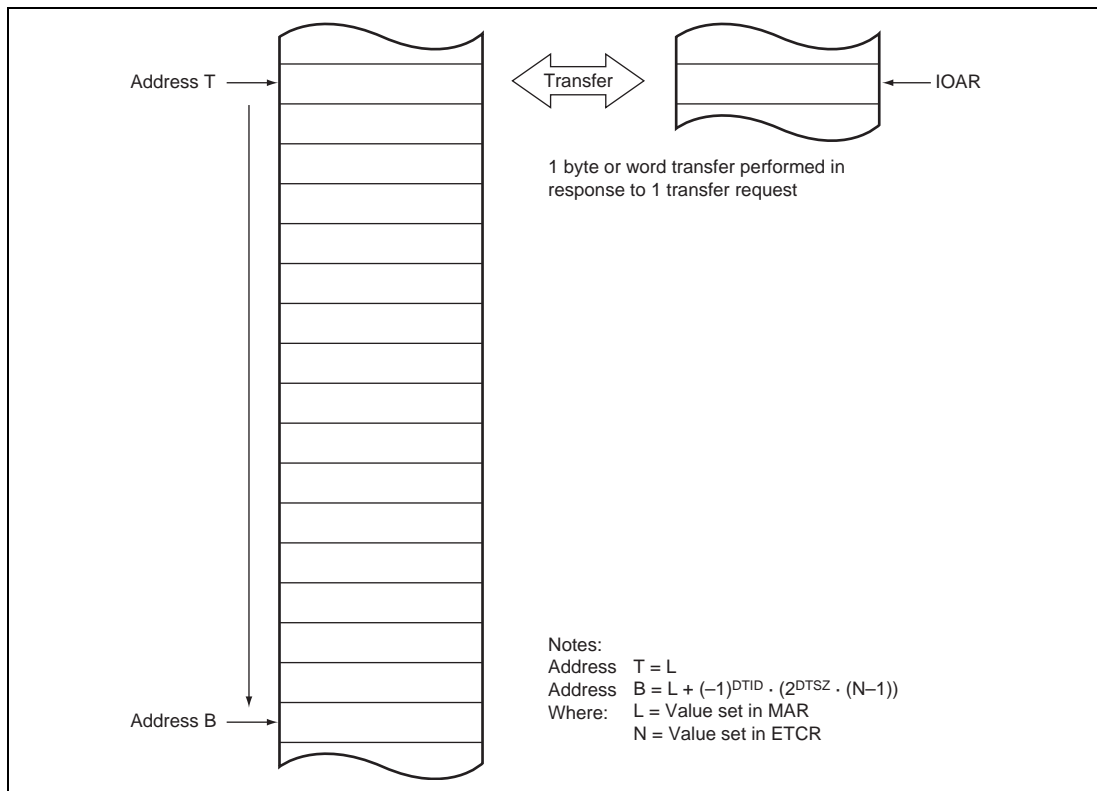
## 7.4.2 Sequential Mode

Sequential mode can be specified by clearing the RPE bit in DMACR to 0. In sequential mode, MAR is updated after each byte or word transfer in response to a single transfer request, and this is executed the number of times specified in ETCR. One address is specified by MAR, and the other by IOAR. The transfer direction can be specified by the DTDIR bit in DMACR. Table 7.3 summarizes register functions in sequential mode.

**Table 7.3 Register Functions in Sequential Mode**

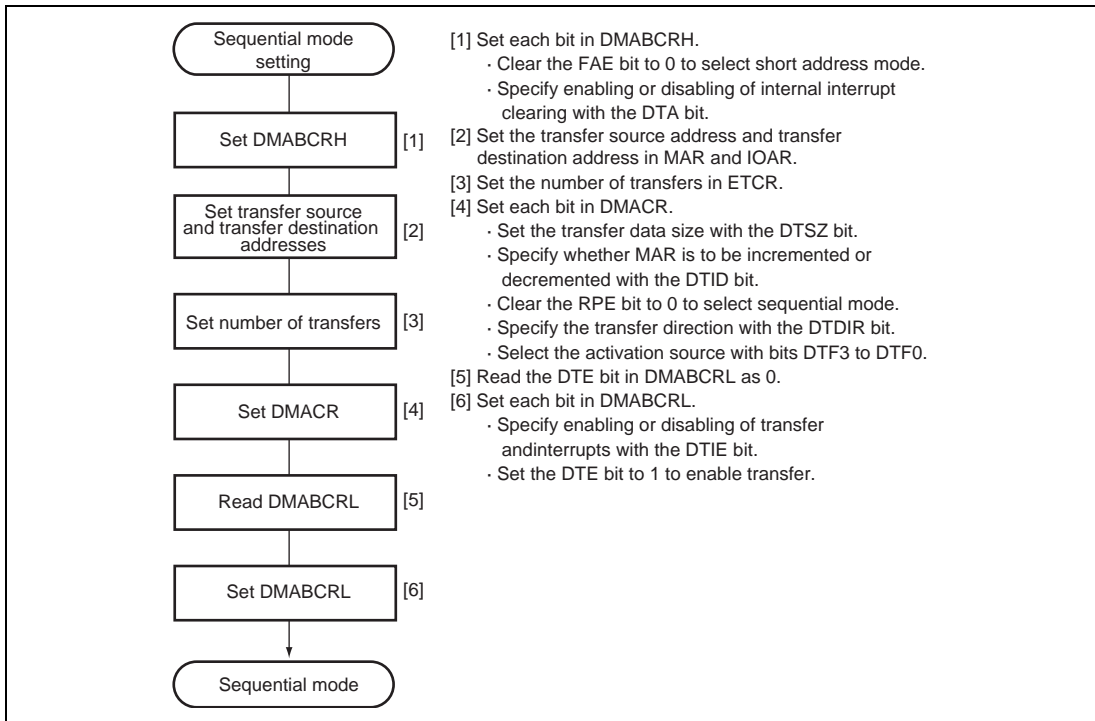
Register	Function		Initial Setting	Operation
	DTDIR = 0	DTDIR = 1		
	Source address register	Destination address register	Start address of transfer destination or transfer source	Incremented/decremented every transfer
	Destination address register	Source address register	Start address of transfer source or transfer destination	Fixed
	Transfer counter		Number of transfers	Decrement every transfer, transfer ends when count reaches H'0000

MAR specifies the start address of the transfer source or transfer destination as 24 bits. MAR is incremented or decremented by 1 or 2 each time a byte or word is transferred. IOAR specifies the lower 16 bits of the other address. The 8 bits above IOAR have a value of H'FF. Figure 7.2 illustrates operation in sequential mode.



**Figure 7.2 Operation in Sequential Mode**

The number of transfers is specified as 16 bits in ETCR. ETCR is decremented by 1 each time a transfer is executed, and when its value reaches H'0000, the DTE bit is cleared and transfer ends. If the DTIE bit is set to 1 at this time, an interrupt request is sent to the CPU. The maximum number of transfers, when H'0000 is set in ETCR, is 65,536. Transfer requests (activation sources) consist of A/D conversion end interrupt, SCI transmission complete and reception complete interrupts, and TPU channel 0 to 2 compare match/input capture A interrupts. Figure 7.3 shows an example of the setting procedure for sequential mode.

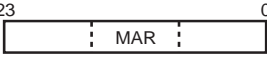
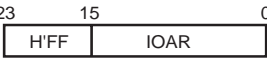



**Figure 7.3 Example of Sequential Mode Setting Procedure**

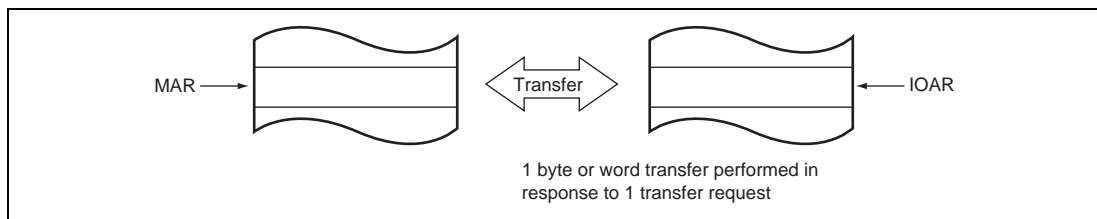
### 7.4.3 Idle Mode

Idle mode can be specified by setting the RPE bit and DTIE bit in DMACR to 1. In idle mode, one byte or word is transferred in response to a single transfer request, and this is executed the number of times specified in ETCR. One address is specified by MAR, and the other by IOAR. The transfer direction can be specified by the DTDIR bit in DMACR. Table 7.4 summarizes register functions in idle mode.

**Table 7.4 Register Functions in Idle Mode**

Register	Function		Initial Setting	Operation
	DTDIR = 0	DTDIR = 1		
	Source address register	Destination address register	Start address of transfer source or transfer destination	Fixed
	Destination address register	Source address register	Start address of transfer source or transfer destination	Fixed
	Transfer counter		Number of transfers	Decrement every transfer, transfer ends when count reaches H'0000

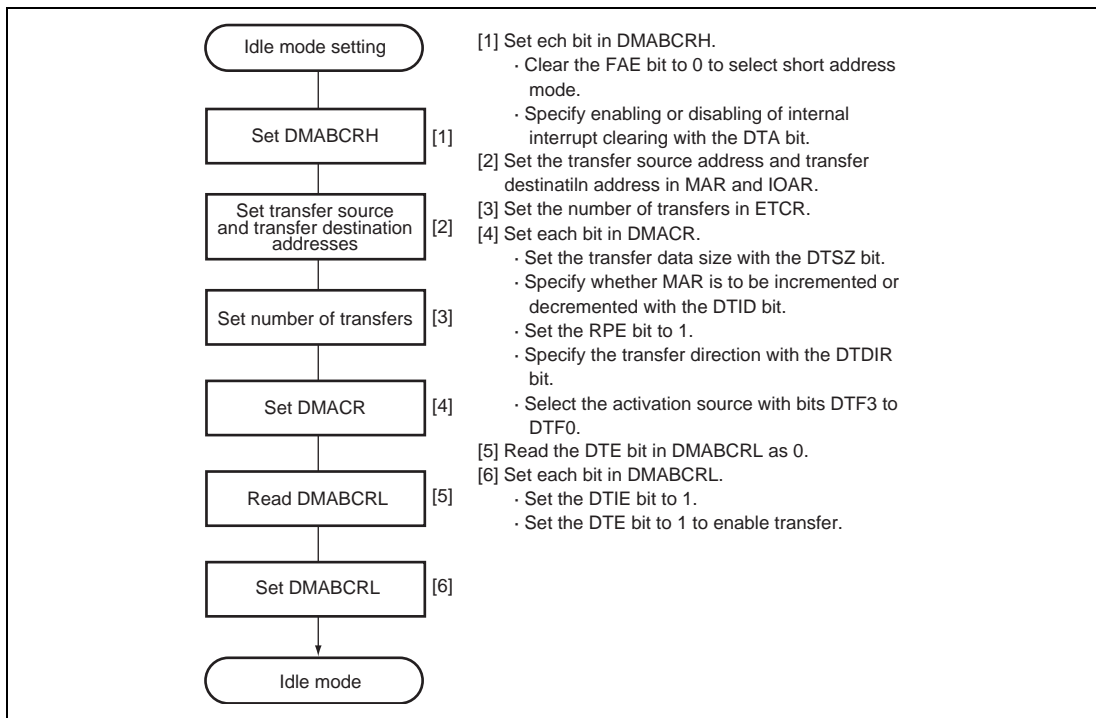
MAR specifies the start address of the transfer source or transfer destination as 24 bits. MAR is neither incremented nor decremented each time a byte or word is transferred. IOAR specifies the lower 16 bits of the other address. The 8 bits above IOAR have a value of H'FF. Figure 7.4 illustrates operation in idle mode.



**Figure 7.4 Operation in Idle Mode**

The number of transfers is specified as 16 bits in ETCR. ETCR is decremented by 1 each time a transfer is executed, and when its value reaches H'0000, the DTE bit is cleared and transfer ends. If the DTIE bit is set to 1 at this time, an interrupt request is sent to the CPU. The maximum number of transfers, when H'0000 is set in ETCR, is 65,536.

Transfer requests (activation sources) consist of A/D conversion end interrupt, SCI transmission complete and reception complete interrupts, and TPU channel 0 to 2 compare match/input capture A interrupts. Figure 7.5 shows an example of the setting procedure for idle mode.

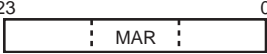


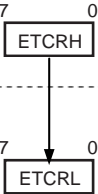


**Figure 7.5 Example of Idle Mode Setting Procedure**

### 7.4.4 Repeat Mode

Repeat mode can be specified by setting the RPE bit in DMACR to 1, and clearing the DTIE bit to 0. In repeat mode, MAR is updated after each byte or word transfer in response to a single transfer request, and this is executed the number of times specified in ETCR. On completion of the specified number of transfers, MAR and ETCR are automatically restored to their original settings and operation continues. One address is specified by MAR, and the other by IOAR. The transfer direction can be specified by the DTDIR bit in DMACR. Table 7.5 summarizes register functions in repeat mode.

**Table 7.5 Register Functions in Repeat Mode**

Register	Function		Initial Setting	Operation
	DTDIR = 0	DTDIR = 1		
	Source address register	Destination address register	Start address of transfer destination or transfer source	Incremented/decremented every transfer. Initial setting is restored when value reaches H'0000
	Destination address register	Source address register	Start address of transfer source or transfer destination	Fixed
	Holds number of transfers		Number of transfers	Fixed
	Transfer counter		Number of transfers	Decrement every transfer. Loaded with ETCRH value when count reaches H'00

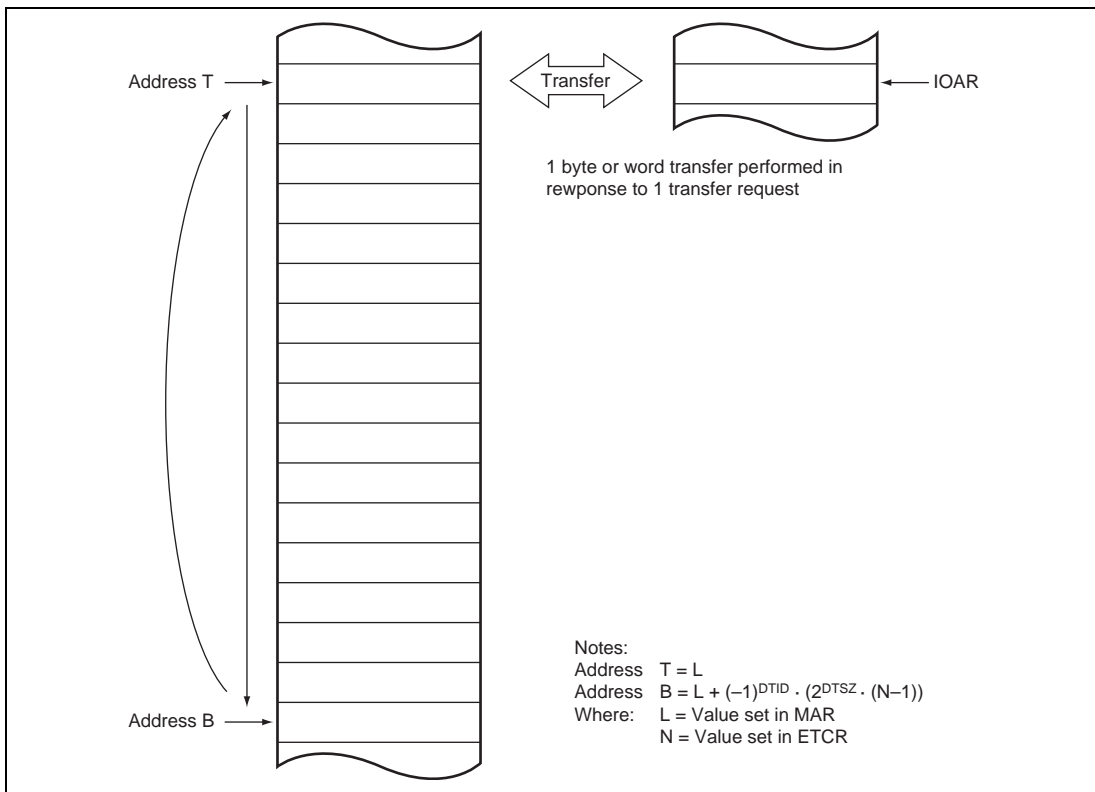
MAR specifies the start address of the transfer source or transfer destination as 24 bits. MAR is incremented or decremented by 1 or 2 each time a byte or word is transferred. IOAR specifies the lower 16 bits of the other address. The 8 bits above IOAR have a value of H'FF. The number of transfers is specified as 8 bits by ETCRH and ETCRL. The maximum number of transfers, when H'00 is set in both ETCRH and ETCRL, is 256.

In repeat mode, ETCRL functions as the transfer counter, and ETCRH is used to hold the number of transfers. ETCRL is decremented by 1 each time a transfer is executed, and when its value reaches H'00, it is loaded with the value in ETCRH. At the same time, the value set in MAR is restored in accordance with the values of the DTSZ and DTID bits in DMACR. The MAR restoration operation is as shown below.

$$\text{MAR} = \text{MAR} - (-1)^{\text{DTID}} \cdot 2^{\text{DTSZ}} \cdot \text{ETCRH}$$

The same value should be set in ETCRH and ETCRL.

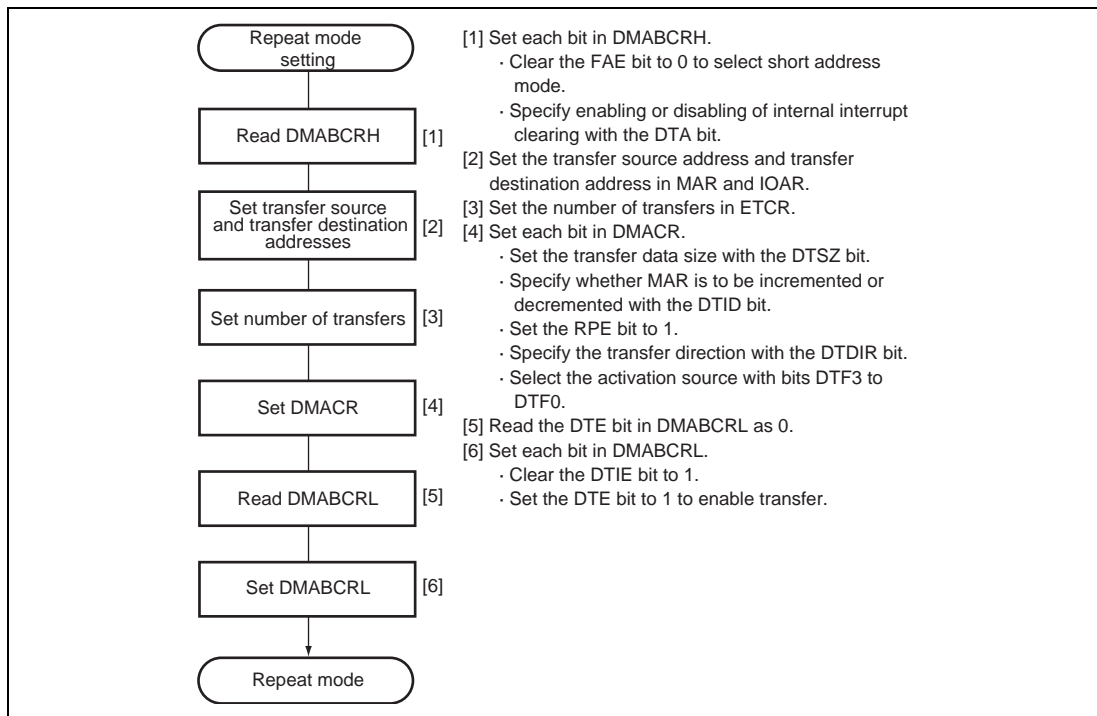
In repeat mode, operation continues until the DTE bit is cleared. To end the transfer operation, therefore, you should clear the DTE bit to 0. A transfer end interrupt request is not sent to the CPU. By setting the DTE bit to 1 again after it has been cleared, the operation can be restarted from the transfer after that terminated when the DTE bit was cleared. Figure 7.6 illustrates operation in repeat mode.



**Figure 7.6 Operation in Repeat mode**



Transfer requests (activation sources) consist of A/D conversion end interrupt, SCI transmission complete and reception complete interrupts, and TPU channel 0 to 2 compare match/input capture A interrupts. Figure 7.7 shows an example of the setting procedure for repeat mode.






**Figure 7.7 Example of Repeat Mode Setting Procedure**

### 7.4.5 Normal Mode

In normal mode, transfer is performed with channels A and B used in combination. Normal mode can be specified by setting the FAE bit in DMABCR to 1 and clearing the BLKE bit in DMACRA to 0. In normal mode, MAR is updated after each byte or word transfer in response to a single transfer request, and this is executed the number of times specified in ETCRA. The transfer source is specified by MARA, and the transfer destination by MARB. Table 7.6 summarizes register functions in normal mode.

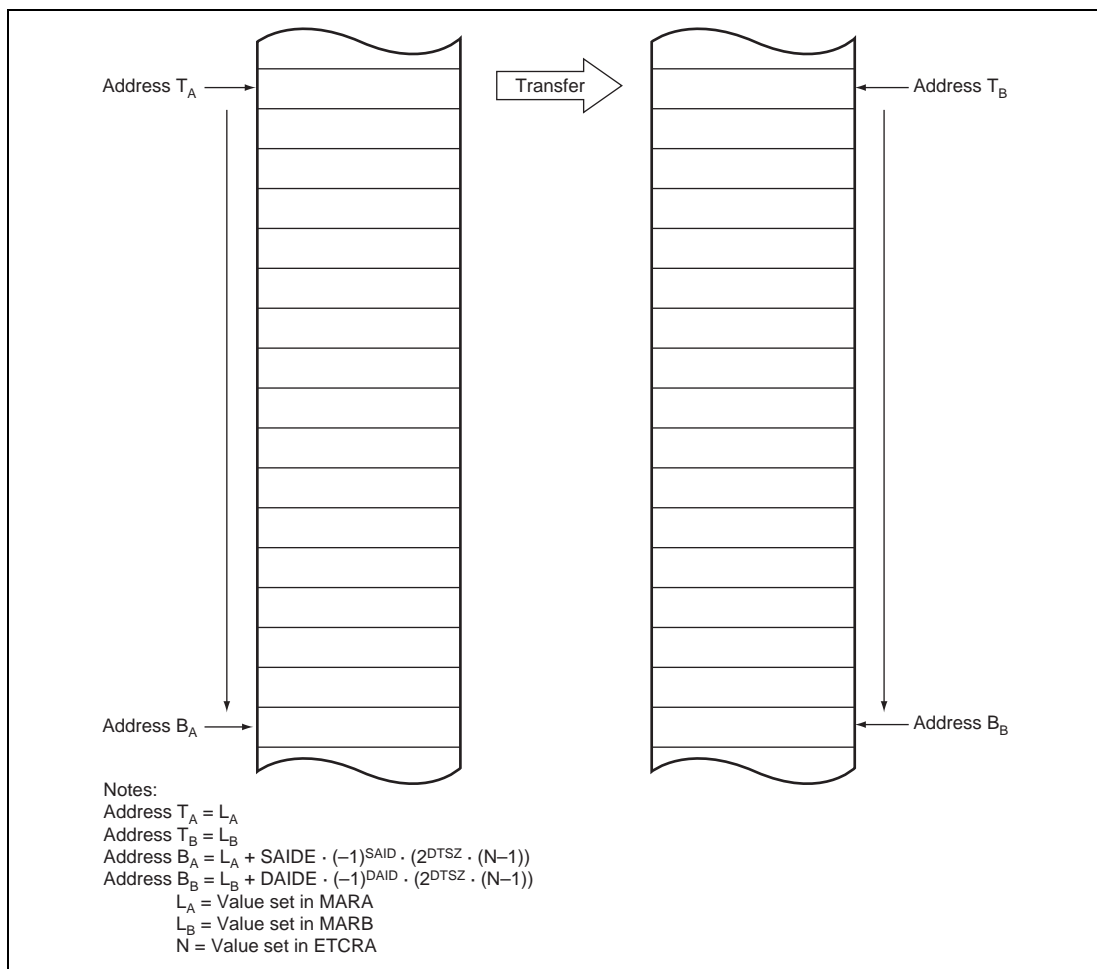
**Table 7.6 Register Functions in Normal Mode**

Register	Function	Initial Setting	Operation
	Source address register	Start address of transfer source	Incremented/decremented every transfer, or fixed
	Destination address register	Start address of transfer destination	Incremented/decremented every transfer, or fixed
	Transfer counter	Number of transfers	Decrement every transfer; transfer ends when count reaches H'0000

MARA and MARB specify the start addresses of the transfer source and transfer destination, respectively, as 24 bits. MAR can be incremented or decremented by 1 or 2 each time a byte or word is transferred, or can be fixed. Incrementing, decrementing, or holding a fixed value can be set separately for MARA and MARB.

The number of transfers is specified by ETCRA as 16 bits. ETCRA is decremented each time a transfer is performed, and when its value reaches H'0000 the DTE bit is cleared and transfer ends. If the DTIE bit is set to 1 at this time, an interrupt request is sent to the CPU. The maximum number of transfers, when H'0000 is set in ETCRA, is 65,536.

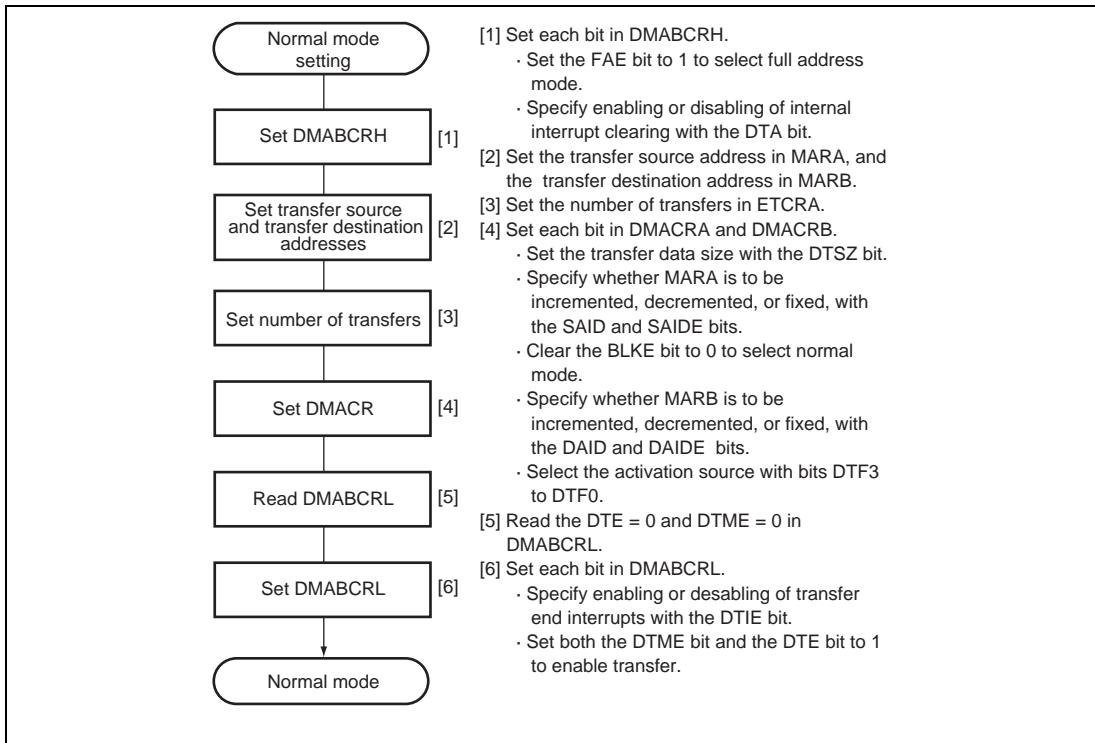
Figure 7.8 illustrates operation in normal mode.



**Figure 7.8 Operation in Normal Mode**

Transfer requests (activation sources) are external requests and auto-requests. With auto-request, the DMAC is only activated by register setting, and the specified number of transfers are performed automatically. With auto-request, cycle steal mode or burst mode can be selected. In cycle steal mode, the bus is released to another bus master each time a transfer is performed. In burst mode, the bus is held continuously until transfer ends. For setting details, see section 7.3.4, DMA Controller Register (DMACR).

Figure 7.9 shows an example of the setting procedure for normal mode.








**Figure 7.9 Example of Normal Mode Setting Procedure**

### 7.4.6 Block Transfer Mode

In block transfer mode, transfer is performed with channels A and B used in combination. Block transfer mode can be specified by setting the FAE bit in DMABCR and the BLKE bit in DMACRA to 1. In block transfer mode, a transfer of the specified block size is carried out in response to a single transfer request, and this is executed the specified number of times. The transfer source is specified by MARA, and the transfer destination by MARB. Either the transfer source or the transfer destination can be selected as a block area (an area composed of a number of bytes or words). Table 7.7 summarizes register functions in block transfer mode.

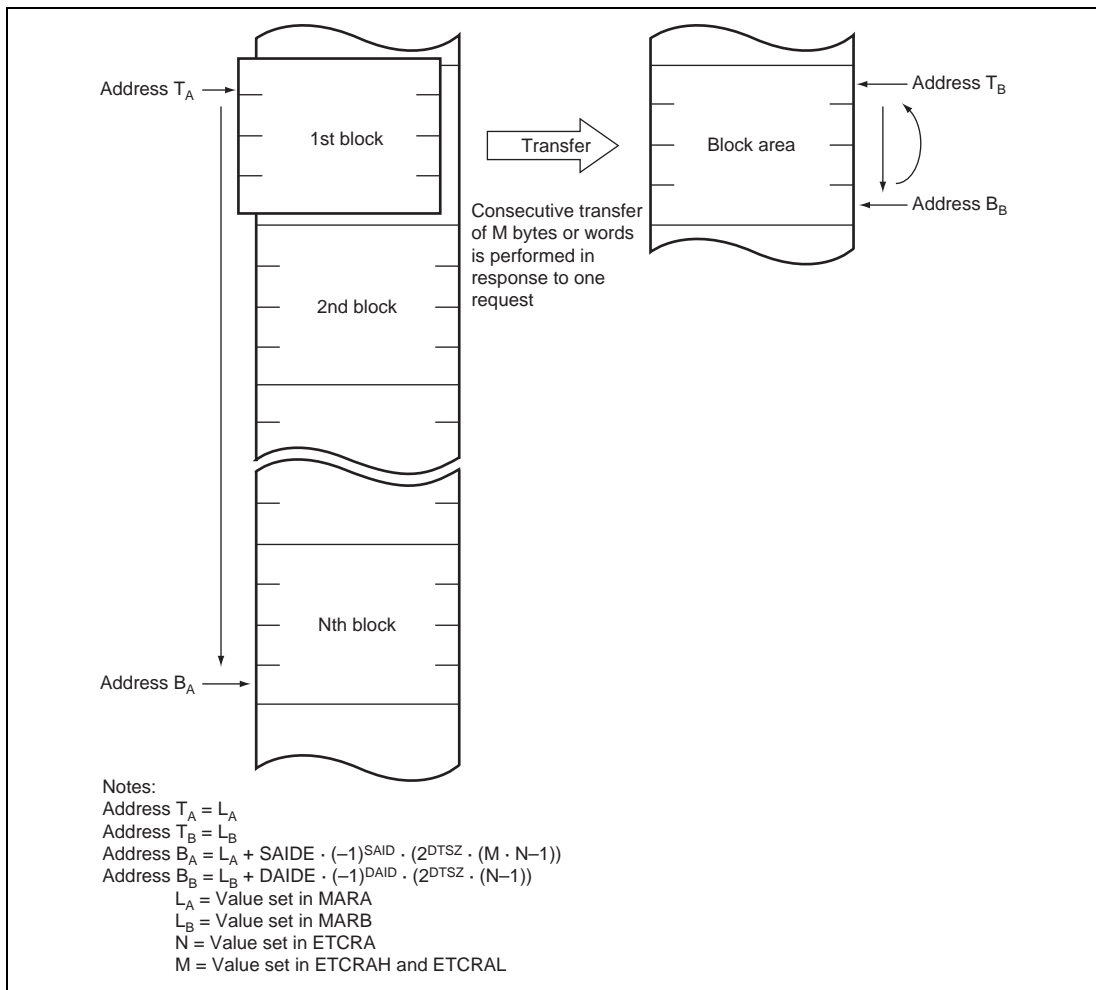
**Table 7.7 Register Functions in Block Transfer Mode**

Register	Function	Initial Setting	Operation
	Source address register	Start address of transfer source	Incremented/decremented every transfer, or fixed
	Description address register	Start address of transfer destination	Incremented/decremented every transfer, or fixed
	Holds block size	Block size	Fixed
	Block size counter	Block size	decremented every transfer; ETCRAH value copied when count reaches H'00
	Block transfer counter	Number of block transfers	Decrementd every block transfer; transfer ends when count reaches H'0000

MARA and MARB specify the start addresses of the transfer source and transfer destination, respectively, as 24 bits. MAR can be incremented or decremented by 1 or 2 each time a byte or word is transferred, or can be fixed. Incrementing, decrementing, or holding a fixed value can be set separately for MARA and MARB. Whether a block is to be designated for MARA or for MARB is specified by the BLKDIR bit in DMACRA.

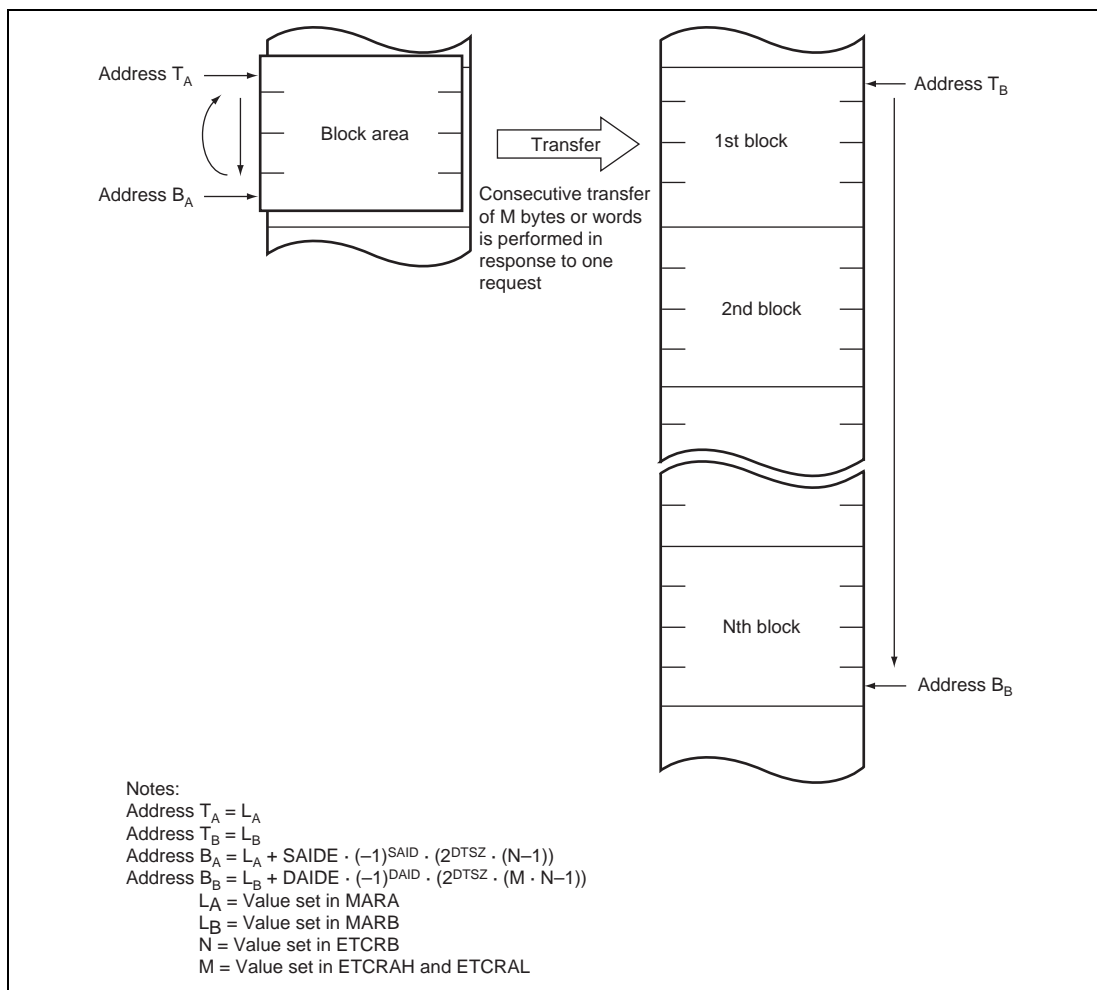
To specify the number of transfers, if M is the size of one block (where M = 1 to 256) and N transfers are to be performed (where N = 1 to 65,536), M is set in both ETCRAH and ETCRAL, and N in ETCRB.

Figure 7.10 illustrates operation in block transfer mode when MARB is designated as a block area.



**Figure 7.10 Operation in Block Transfer Mode (BLKDIR = 0)**

Figure 7.11 illustrates operation in block transfer mode when MARA is designated as a block area.



**Figure 7.11 Operation in Block Transfer Mode (BLKDIR = 1)**

ETCRAL is decremented by 1 each time a byte or word transfer is performed. In response to a single transfer request, burst transfer is performed until the value in ETCRAL reaches H'00. ETCRAL is then loaded with the value in ETCRAH. At this time, the value in the MAR register for which a block designation has been given by the BLKDIR bit in DMACRA is restored in accordance with the DTSZ, SAID/DAID, and SAIDE/DAIDE bits in DMACR.

ETCRB is decremented by 1 every block transfer, and when the count reaches H'0000 the DTE bit is cleared and transfer ends. If the DTIE bit is set to 1 at this point, an interrupt request is sent to the CPU. Figure 7.12 shows the operation flow in block transfer mode.

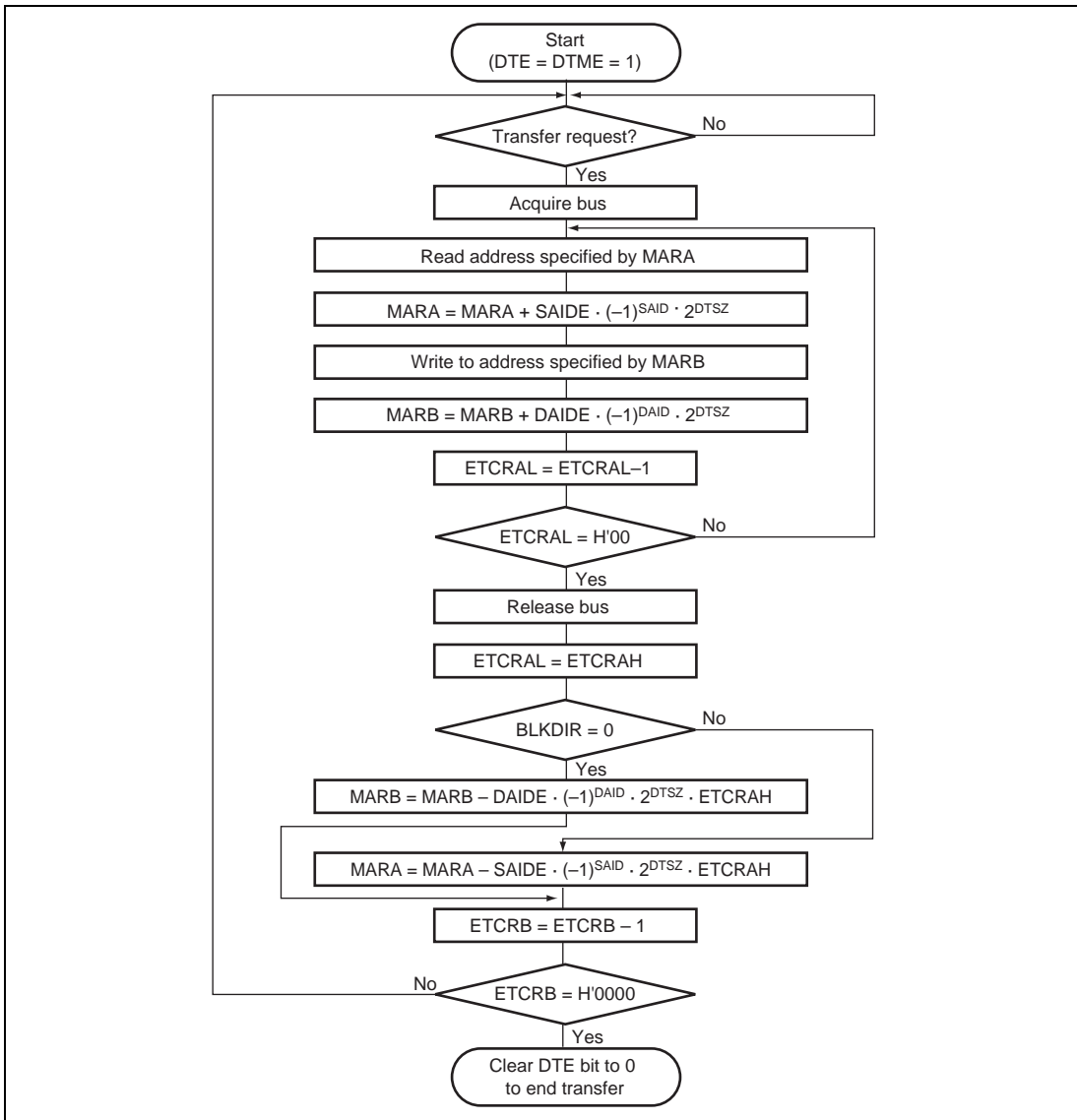
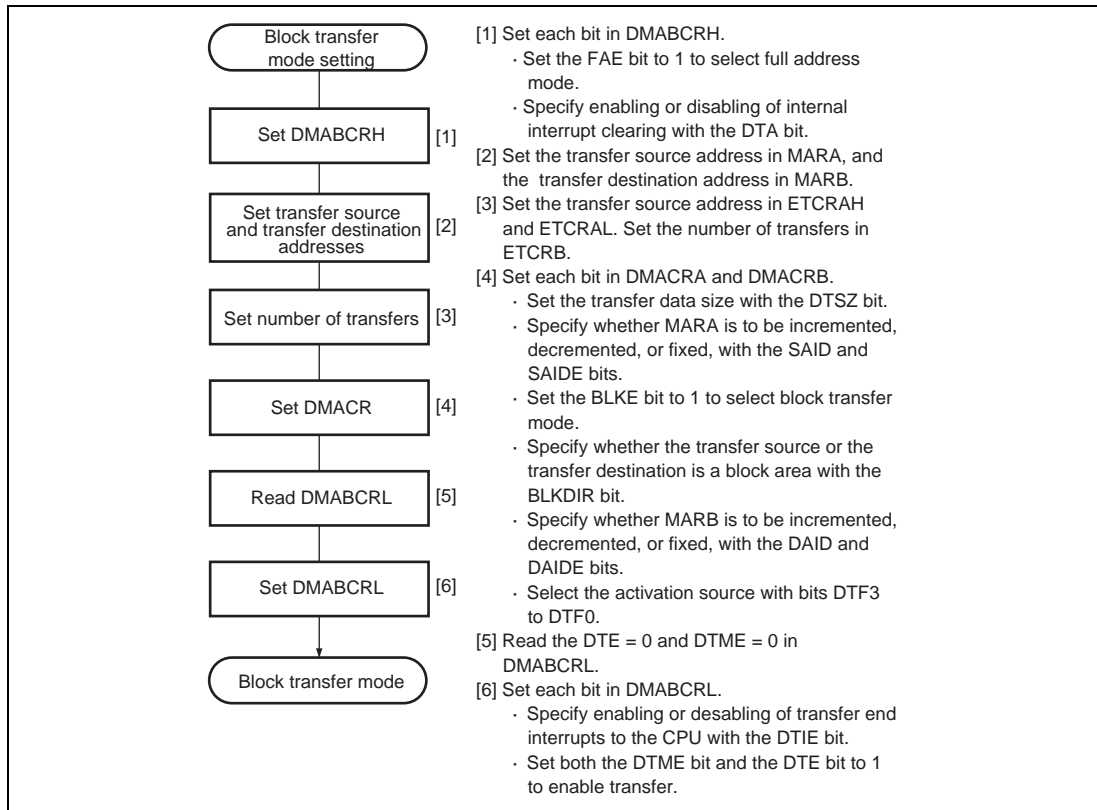


Figure 7.12 Operation Flow in Block Transfer Mode



Transfer requests (activation sources) consist of A/D conversion end interrupt, SCI transmission complete and reception complete interrupts, and TPU channel 0 to 2 compare match/input capture A interrupts. For details, see section 7.3.4, DMA Control Register (DMACR). Figure 7.13 shows an example of the setting procedure for block transfer mode.



**Figure 7.13 Example of Block Transfer Mode Setting Procedure**

### 7.4.7 DMAC Activation Sources

DMAC activation sources consist of internal interrupts, external requests, and auto-requests. The activation sources that can be specified depend on the transfer mode, as shown in table 7.8.

**Table 7.8 DMAC Activation Sources**

Activation Source		Full Address Mode		
		Short Address Mode	Normal Mode	Block Transfer Mode
Internal	ADI	○	×	○
Interrupt	TXI0	○	×	○
	RXI0	○	×	○
	TGI0A	○	×	○
	TGI1A	○	×	○
	TGI2A	○	×	○
	USB request	Low level input of the $\overline{\text{DREQ}}$ signal	×	○
Auto-request		×	○	×

Legend:

○ : Can be specified

×: Cannot be specified

**Activation by Internal Interrupt:** An interrupt request selected as a DMAC activation source can be sent simultaneously to the CPU. For details, see section 5, Interrupt Controller.

With activation by an internal interrupt, the DMAC accepts the request independently of the interrupt controller. Consequently, interrupt controller priority settings are not accepted.

If the DMAC is activated by an interrupt request that is not used as a CPU interrupt source ( $\text{DTA} = 1$ ), the interrupt source flag is cleared automatically by the DMA transfer. With ADI, TXI, and RXI interrupts, however, the interrupt source flag is not cleared unless the prescribed register is accessed in a DMA transfer. If the same interrupt is used as an activation source for more than one channel, the interrupt request flag is cleared when the highest-priority channel is activated first. Transfer requests for other channels are held pending in the DMAC, and activation is carried out in order of priority.

When  $\text{DTE} = 0$ , such as after completion of a transfer, a request from the selected activation source is not sent to the DMAC, regardless of the DTA bit. In this case, the relevant interrupt request is sent to the CPU. In case of overlap with a CPU interrupt source ( $\text{DTA} = 0$ ), the interrupt request flag is not cleared by the DMAC.

---

**Activation by USB Request:** The USB request ( $\overline{\text{DREQ}}$  signal) is specified as a DMAC activation source. The USB request is generated by the level sense. In full-address normal mode, the USB request is carried out as follows.

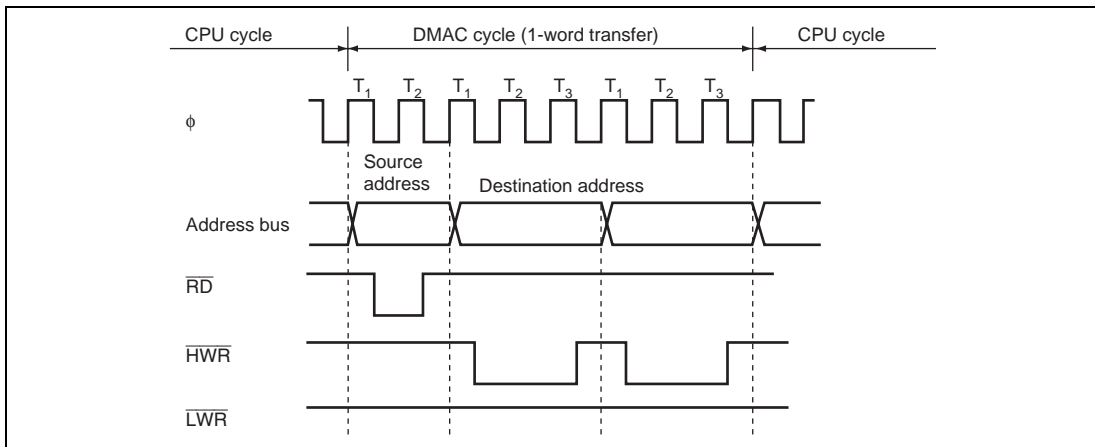
While the  $\overline{\text{DREQ}}$  signal is kept high, the DMAC waits for the transfer request. While the  $\overline{\text{DREQ}}$  signal is kept low, the DMAC releases the bus each time a byte is transferred and the transfer is performed continuously. When the  $\overline{\text{DREQ}}$  signal is driven high during the transfer, the transfer is halted and the DMAC waits for the transfer request.

**Activation by Auto-Request:** Auto-request activation is performed by register setting only, and transfer continues to the end. With auto-request activation, cycle steal mode or burst mode can be selected.

In cycle steal mode, the DMAC releases the bus to another bus master each time a byte or word is transferred. DMA and CPU cycles usually alternate. In burst mode, the DMAC keeps possession of the bus until the end of the transfer, and transfer is performed continuously.

### 7.4.8 Basic DMAC Bus Cycles

An example of the basic DMAC bus cycle timing is shown in figure 7.14. In this example, word-size transfer is performed from 16-bit, 2-state access space to 8-bit, 3-state access space. When the bus is transferred from the CPU to the DMAC, a source address read and destination address write are performed. The bus is not released in response to another bus request, etc., between these read and write operations. As with CPU cycles, DMA cycles conform to the bus controller settings.

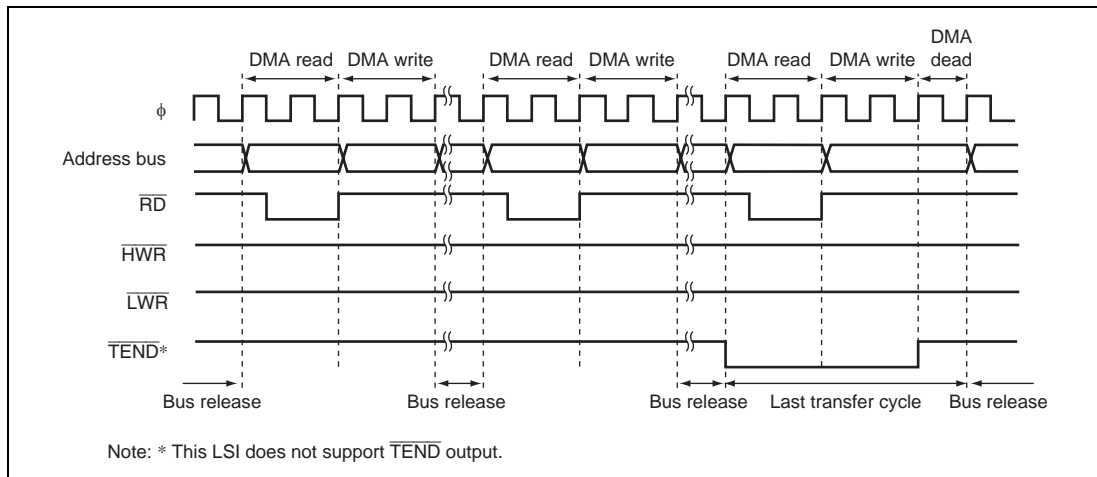


**Figure 7.14 Example of DMA Transfer Bus Timing**

The address is not output to the external address bus in an access to on-chip memory or an internal I/O register.

### 7.4.9 DMAC Bus Cycles (Dual Address Mode)

**Short Address Mode:** Figure 7.15 shows a transfer example in which  $\overline{\text{TEND}}^*$  output is enabled and byte-size short address mode transfer (sequential/idle/repeat mode) is performed from external 8-bit, 2-state access space to internal I/O space.



**Figure 7.15 Example of Short Address Mode Transfer**

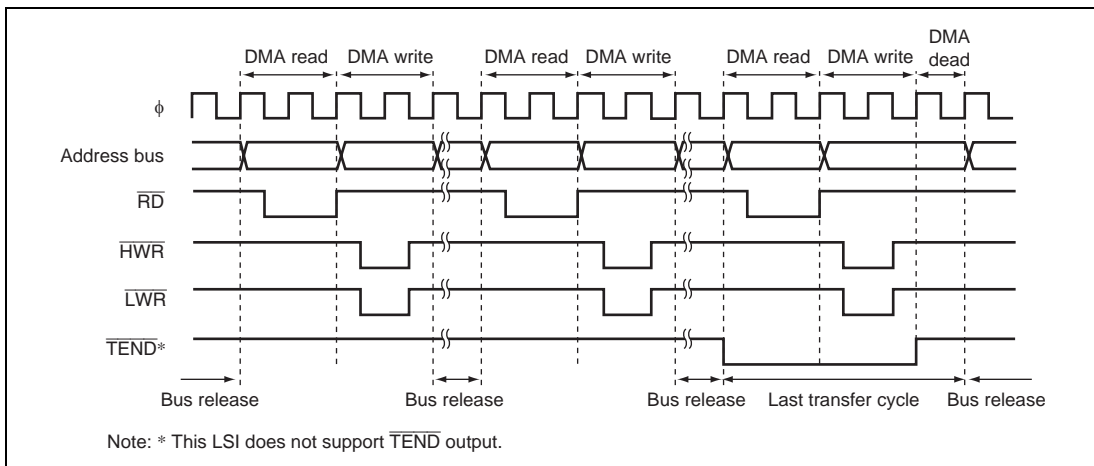
A one-byte or one-word transfer is performed for one transfer request, and after the transfer the bus is released. While the bus is released one or more bus cycles are inserted by the CPU.

In the transfer end cycle (the cycle in which the transfer counter reaches 0), a one-state DMA dead cycle is inserted after the DMA write cycle.

In repeat mode, when  $\overline{\text{TEND}}^*$  output is enabled,  $\overline{\text{TEND}}^*$  output goes low in the transfer cycle in which the transfer counter reaches 0.

Note: \* This LSI does not support  $\overline{\text{TEND}}$  output.

**Full Address Mode (Cycle Steal Mode):** Figure 7.16 shows a transfer example in which  $\overline{\text{TEND}}^*$  output is enabled and word-size full address mode transfer (cycle steal mode) is performed from external 16-bit, 2-state access space to external 16-bit, 2-state access space.



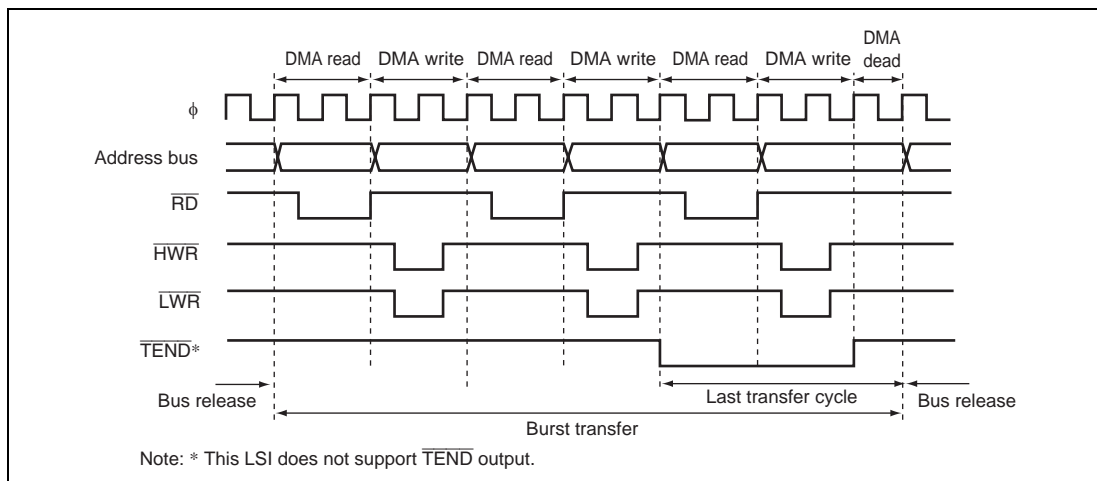
**Figure 7.16 Example of Full Address Mode (Cycle Steal) Transfer**

A one-byte or one-word transfer is performed, and after the transfer the bus is released. While the bus is released one bus cycle is inserted by the CPU.

In the transfer end cycle (the cycle in which the transfer counter reaches 0), a one-state DMA dead cycle is inserted after the DMA write cycle.

Note: \* This LSI does not support  $\overline{\text{TEND}}$  output.

**Full Address Mode (Burst Mode):** Figure 7.17 shows a transfer example in which  $\overline{\text{TEND}}^*$  output is enabled and word-size full address mode transfer (burst mode) is performed from external 16-bit, 2-state access space to external 16-bit, 2-state access space.



**Figure 7.17 Example of Full Address Mode (Burst Mode) Transfer**

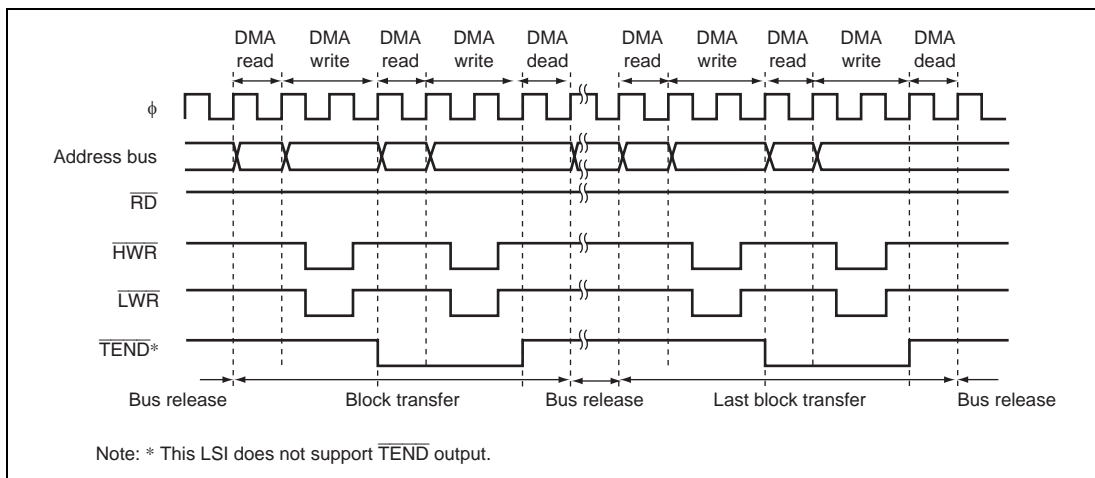
In burst mode, one-byte or one-word transfers are executed consecutively until transfer ends. In the transfer end cycle (the cycle in which the transfer counter reaches 0), a one-state DMA dead cycle is inserted after the DMA write cycle.

If a request from another higher-priority channel is generated after burst transfer starts, that channel has to wait until the burst transfer ends.

If an NMI is generated while a channel designated for burst transfer is in the transfer enabled state, the DTME bit is cleared and the channel is placed in the transfer disabled state. If burst transfer has already been activated inside the DMAC, the bus is released on completion of a one-byte or one-word transfer within the burst transfer, and burst transfer is suspended. If the last transfer cycle of the burst transfer has already been activated inside the DMAC, execution continues to the end of the transfer even if the DTME bit is cleared.

Note: \* This LSI does not support  $\overline{\text{TEND}}$  output.

**Full Address Mode (Block Transfer Mode):** Figure 7.18 shows a transfer example in which  $\overline{\text{TEND}}^*$  output is enabled and word-size full address mode transfer (block transfer mode) is performed from internal 16-bit, 1-state access space to external 16-bit, 2-state access space.



**Figure 7.18 Example of Full Address Mode (Block Transfer Mode) Transfer**

A one-block transfer is performed for one transfer request, and after the transfer the bus is released. While the bus is released, one or more bus cycles are inserted by the CPU.

In the transfer end cycle of each block (the cycle in which the transfer counter reaches 0), a one-state DMA dead cycle is inserted after the DMA write cycle.

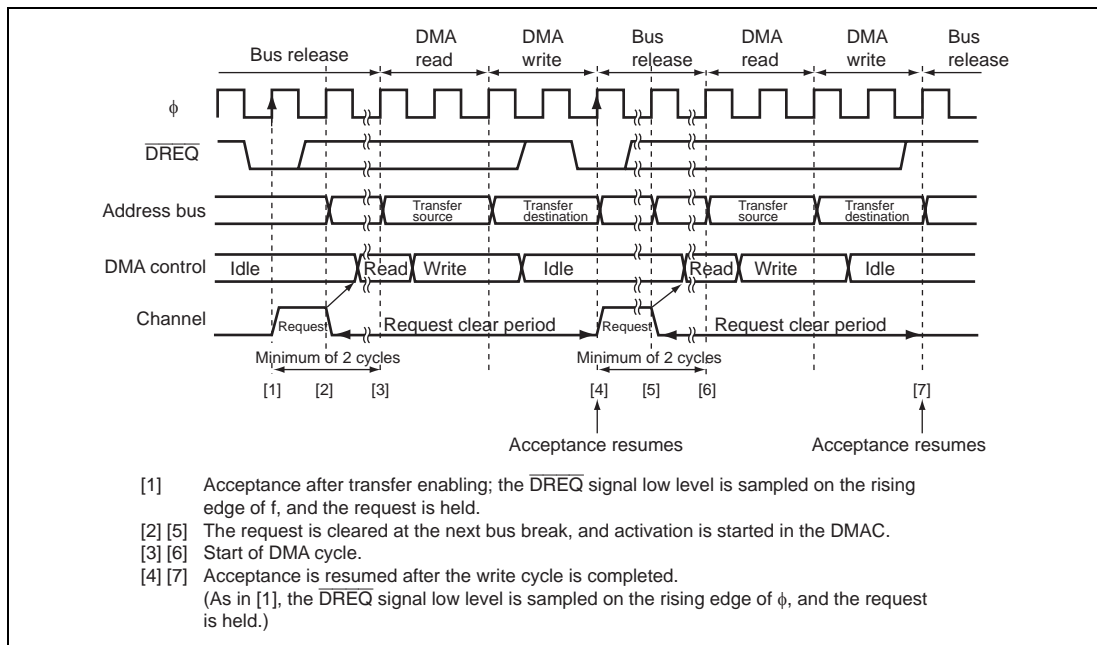
One block is transmitted without interruption. NMI generation does not affect block transfer operation.

Note: \* This LSI does not support  $\overline{\text{TEND}}$  output.



**$\overline{\text{DREQ}}$  Signal Level Activation Timing (Normal Mode):** Set the DTA bit for the channel for which the  $\overline{\text{DREQ}}$  signal is selected to 1.

Figure 7.19 shows an example of  $\overline{\text{DREQ}}$  level activated normal mode transfer.



**Figure 7.19 Example of  $\overline{\text{DREQ}}$  Level Activated Normal Mode Transfer**

$\overline{\text{DREQ}}$  signal sampling is performed every cycle, with the rising edge of the next  $\phi$  cycle after the end of the DMABCR write cycle for setting the transfer enabled state as the starting point.

When the  $\overline{\text{DREQ}}$  signal low level is sampled while acceptance by means of the  $\overline{\text{DREQ}}$  signal is possible, the request is held in the DMAC. Then, when activation is initiated in the DMAC, the request is cleared. Acceptance resumes after the end of the write cycle,  $\overline{\text{DREQ}}$  signal low level sampling is performed again, and this operation is repeated until the transfer ends.

Note: The  $\overline{\text{DREQ}}$  signal of this chip is an internal signal of chip, so it is not output from the pin.

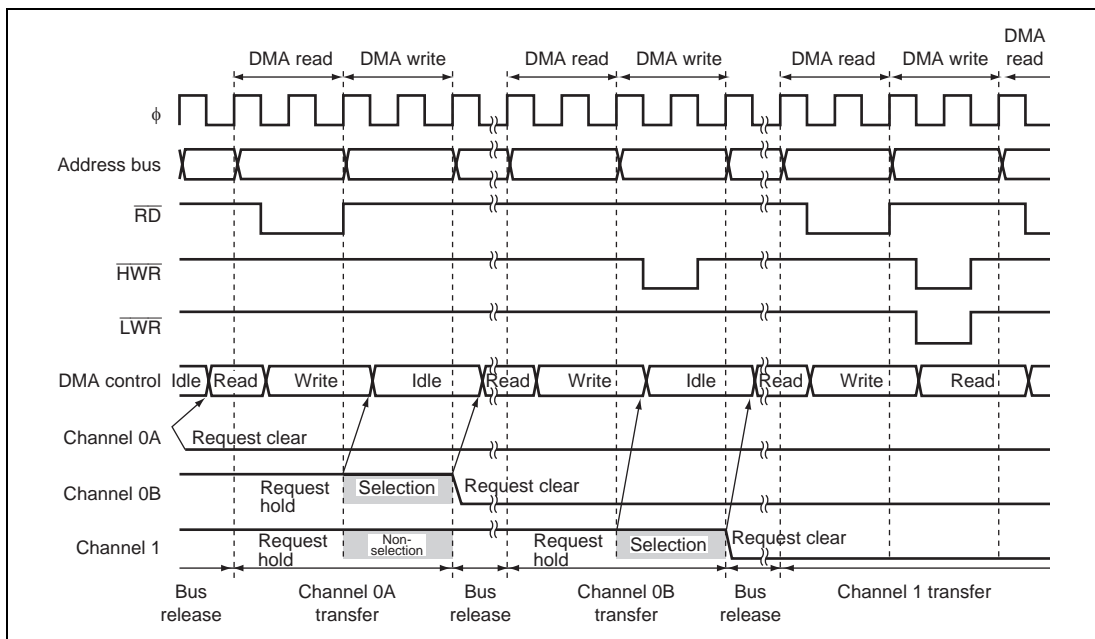
### 7.4.10 DMAC Multi-Channel Operation

The DMAC channel priority order is: channel 0 > channel 1, and channel A > channel B. Table 7.9 summarizes the priority order for DMAC channels.

**Table 7.9 DMAC Channel Priority Order**

Short Address Mode	Full Address Mode	Priority
Channel 0A	Channel 0	High
Channel 0B		
Channel 1A	Channel 1	Low
Channel 1B		

If transfer requests are issued simultaneously for more than one channel, or if a transfer request for another channel is issued during a transfer, when the bus is released the DMAC selects the highest-priority channel from among those issuing a request according to the priority order shown in table 7.9. During burst transfer, or when one block is being transferred in block transfer, the channel will not be changed until the end of the transfer. Figure 7.20 shows a transfer example in which transfer requests are issued simultaneously for channels 0A, 0B, and 1.



**Figure 7.20 Example of Multi-Channel Transfer**

### 7.4.11 Relation between the DMAC and External Bus Requests

There can be no break between a DMA cycle read and a DMA cycle write. This means that an external bus release cycle is not generated between the external read and external write in a DMA cycle.

In the case of successive read and write cycles, such as in burst transfer or block transfer, an external bus released state may be inserted after a write cycle.

When DMA cycle reads or writes are accesses to on-chip memory or internal I/O registers, these DMA cycles can be executed at the same time as refresh cycles or external bus release. However, simultaneous operation may not be possible when a write buffer is used.

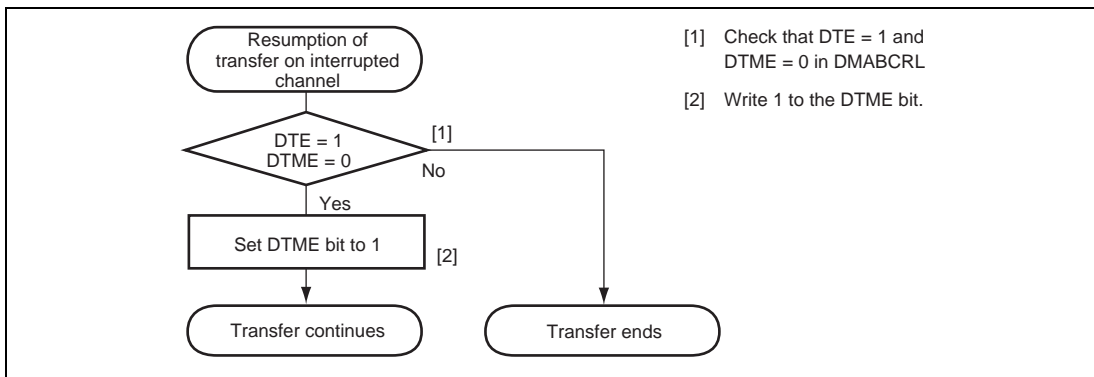
### 7.4.12 NMI Interrupts and DMAC

When an NMI interrupt is requested, burst mode transfer in full address mode is interrupted. An NMI interrupt does not affect the operation of the DMAC in other modes.

In full address mode, transfer is enabled for a channel when both the DTE bit and the DTME bit are set to 1. With burst mode setting, the DTME bit is cleared when an NMI interrupt is requested.

If the DTME bit is cleared during burst mode transfer, the DMAC discontinues transfer on completion of the 1-byte or 1-word transfer in progress, then releases the bus, which passes to the CPU.

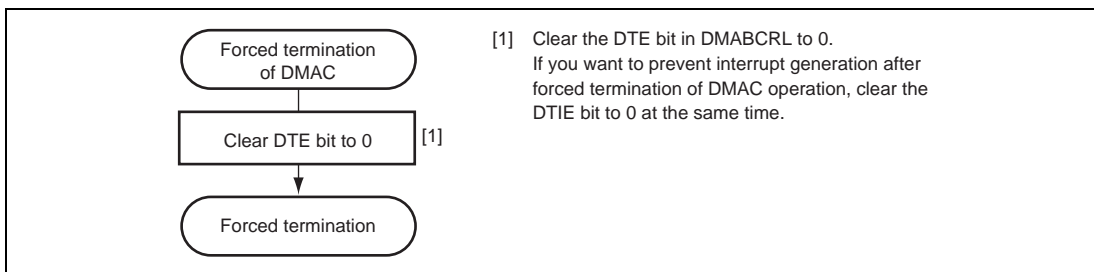
The channel on which transfer was interrupted can be restarted by setting the DTME bit to 1 again. Figure 7.21 shows the procedure for continuing transfer when it has been interrupted by an NMI interrupt on a channel designated for burst mode transfer.



**Figure 7.21 Example of Procedure for Continuing Transfer on Channel Interrupted by NMI Interrupt**

### 7.4.13 Forced Termination of DMAC Operation

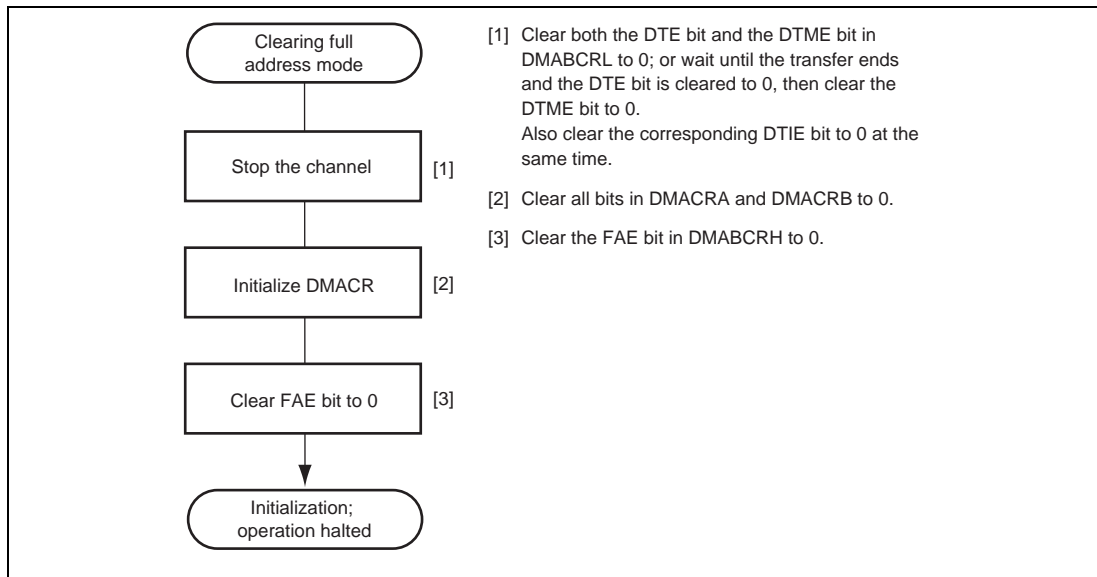
If the DTE bit for the channel currently operating is cleared to 0, the DMAC stops on completion of the 1-byte or 1-word transfer in progress. DMAC operation resumes when the DTE bit is set to 1 again. In full address mode, the same applies to the DTME bit. Figure 7.22 shows the procedure for forcibly terminating DMAC operation by software.



**Figure 7.22 Example of Procedure for Forcibly Terminating DMAC Operation**

### 7.4.14 Clearing Full Address Mode

Figure 7.23 shows the procedure for releasing and initializing a channel designated for full address mode. After full address mode has been cleared, the channel can be set to another transfer mode using the appropriate setting procedure.



**Figure 7.23 Example of Procedure for Clearing Full Address Mode**

## 7.5 Interrupts

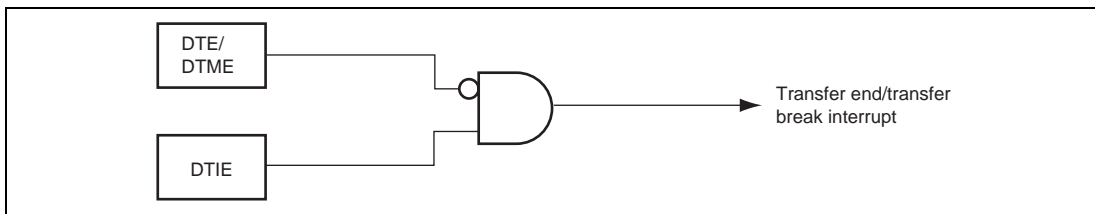
The sources of interrupts generated by the DMAC are transfer end and transfer break. Table 7.10 shows the interrupt sources and their priority order.

**Table 7.10 Interrupt Source Priority Order**

Interrupt Name	Interrupt Source		Interrupt Priority Order
	Short Address Mode	Full Address Mode	
DEND0A	Interrupt due to end of transfer on channel 0A	Interrupt due to end of transfer on channel 0	↑ High   Low
DEND0B	Interrupt due to end of transfer on channel 0B	Interrupt due to break in transfer on channel 0	
DEND1A	Interrupt due to end of transfer on channel 1A	Interrupt due to end of transfer on channel 1	
DEND1B	Interrupt due to end of transfer on channel 1B	Interrupt due to break in transfer on channel 1	

Enabling or disabling of each interrupt source is set by means of the DTIE bit for the corresponding channel in DMABCR, and interrupts from each source are sent to the interrupt controller independently. The relative priority of transfer end interrupts on each channel is decided by the interrupt controller, as shown in table 7.10.

Figure 7.24 shows a block diagram of a transfer end/transfer break interrupt. An interrupt is always generated when the DTIE bit is set to 1 while DTE bit is cleared to 0.



**Figure 7.24 Block Diagram of Transfer End/Transfer Break Interrupt**

In full address mode, a transfer break interrupt is generated when the DTME bit is cleared to 0 while DTIEB bit is set to 1. In both short address mode and full address mode, DMABCR should be set so as to prevent the occurrence of a combination that constitutes a condition for interrupt generation during setting.

## 7.6 Usage Notes

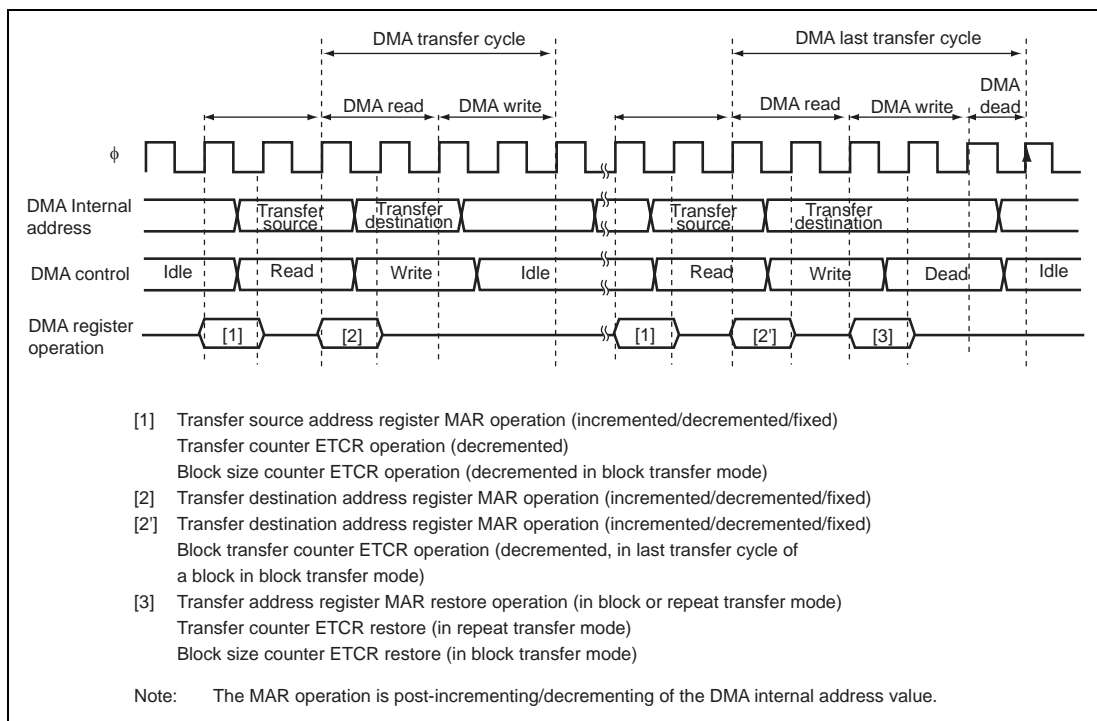
### 7.6.1 DMAC Register Access during Operation

Except for forced termination, the operating (including transfer waiting state) channel setting should not be changed. The operating channel setting should only be changed when transfer is disabled. Also, the DMAC register should not be written to in a DMA transfer.

DMAC register reads during operation (including the transfer waiting state) are described below.

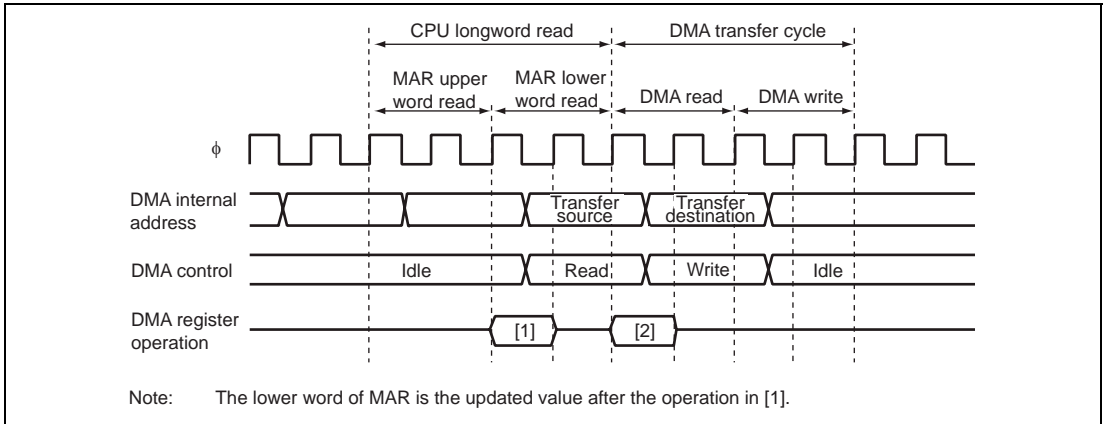
1. DMAC control starts one cycle before the bus cycle, with output of the internal address. Consequently, MAR is updated in the bus cycle before DMAC transfer.

Figure 7.25 shows an example of the update timing for DMAC registers in dual address transfer mode.



**Figure 7.25 DMAC Register Update Timing**

2. If a DMAC transfer cycle occurs immediately after a DMAC register read cycle, the DMAC register is read as shown in figure 7.26.



**Figure 7.26 Contention between DMAC Register Update and CPU Read**

### 7.6.2 Module Stop

When the MSTPA7 bit in MSTPCR is set to 1, the DMAC clock stops, and the module stop state is entered. However, 1 cannot be written to the MSTPA7 bit if any of the DMAC channels is enabled. This setting should therefore be made when DMAC operation is stopped.

When the DMAC clock stops, DMAC register accesses can no longer be made. Since the following DMAC register settings are valid even in the module stop state, they should be invalidated, if necessary, before a module stop.

- Transfer end/suspend interrupt (DTE = 0 and DTIE = 1)  
For details, refer to section 20, Power-Down Modes.

### 7.6.3 Medium-Speed Mode

When the DTA bit is 0, internal interrupt signals specified as DMAC transfer sources are edge-detected. In medium-speed mode, the DMAC operates on a medium-speed clock, while on-chip peripheral modules operate on a high-speed clock.

Consequently, if the period in which the relevant interrupt source is cleared by the CPU or another DMAC channel, and the next interrupt is generated, is less than one state with respect to the DMAC clock (bus master clock), edge detection may not be possible and the interrupt may be ignored.



#### 7.6.4 Activation Source Acceptance

At the start of activation source acceptance, a low level is detected in both  $\overline{\text{DREQ}}$  signal falling edge sensing and low level sensing. Similarly, in the case of an internal interrupt, the interrupt request is detected. Therefore, a request is accepted from an internal interrupt or  $\overline{\text{DREQ}}$  pin low level that occurs before execution of the DMABCRL write to enable transfer.

When the DMAC is activated, take any necessary steps to prevent an internal interrupt or  $\overline{\text{DREQ}}$  signal low level remaining from the end of the previous transfer, etc.

#### 7.6.5 Internal Interrupt after End of Transfer

When the DTE bit is cleared to 0 by the end of transfer or an abort, the selected internal interrupt request will be sent to the CPU even if DTA is set to 1.

Also, if internal DMAC activation has already been initiated when operation is aborted, the transfer is executed but flag clearing is not performed for the selected internal interrupt even if DTA is set to 1.

An internal interrupt request following the end of transfer or an abort should be handled by the CPU as necessary.

#### 7.6.6 Channel Re-Setting

To reactivate a number of channels when multiple channels are enabled, use exclusive handling of transfer end interrupts, and perform DMABCR control bit operations exclusively. Note, in particular, that in cases where multiple interrupts are generated between reading and writing of DMABCR, and a DMABCR operation is performed during new interrupt handling, the DMABCR write data in the original interrupt handling routine will be incorrect, and the write may invalidate the results of the operations by the multiple interrupts. Ensure that overlapping DMABCR operations are not performed by multiple interrupts, and that there is no separation between read and write operations by the use of a bit-manipulation instruction. Also, when the DTE and DTME bits are cleared by the DMAC or are written with 0, they must first be read while cleared to 0 before the CPU can write a 1 to them.



## Section 8 I/O Ports

Table 8.1 and table 8.2 summarize the port functions of the H8S/2218 Group and H8S/2212 Group respectively. The pins of each port also have other functions such as input/output or external interrupt input pins of on-chip peripheral modules. Each I/O port includes a data direction register (DDR) that controls input/output, a data register (DR) that stores output data, and a port register (PORT) used to read the pin states. The input-only ports do not have DR and DDR.

Ports A to E have an on-chip input pull-up MOS and a input pull-up MOS control register (PCR) to control the on/off state of the input pull-up MOS. Ports 3 and A include an open-drain control register (ODR) that controls the on/off state of the output buffer PMOS.

All the I/O ports can drive a single TTL load and 30-pF capacitive load.

**Table 8.1 Port Functions of H8S/2218 Group**

Port	Description	Modes 4 and 5	Mode 6	Mode 7	Input/Output Type		
Port 1	General I/O port also functioning as TPU I/O pins, interrupt input pins, and address bus output pins	P17/TIOCB2/TCLKD				Schmitt trigger input ( $\overline{\text{IRQ1}}$ , $\overline{\text{IRQ0}}$ )	
		P16/TIOCA2/ $\overline{\text{IRQ1}}$					
		P15/TIOCB1/TCLKC					
				P14/TIOCA1/ $\overline{\text{IRQ0}}$			
		P13/TIOCD0/TCLKB/A23			P13/TIOCD0/TCLKB		
		P12/TIOCC0/TCLKA/A22			P12/TIOCC0/TCLKA		
		P11/TIOCB0/A21			P11/TIOCB0		
P10/TIOCA0/A20			P10/TIOCA0				
Port 3	General I/O port also functioning as SCI_0 I/O pins and interrupt input pins	P36				Open-drain output	
		P32/SCK0/ $\overline{\text{IRQ4}}$					
		P31/RxD0					Schmitt trigger input ( $\overline{\text{IRQ4}}$ )
		P30/TxD0					
Port 4	General input port also functioning as A/D converter analog input pins	P43/AN3					
		P42/AN2					
		P41/AN1					
		P40/AN0					
Port 7	General I/O port also functioning as bus control output pins and manual reset input pins	P74/MRES		P74/MRES			
		P71/CS5		P71			
		P70/CS4		P70			

Port	Description	Modes 4 and 5	Mode 6	Mode 7	Input/Output Type
Port 9	General input port also functioning as A/D converter analog input pins	P97/AN15 P96/AN14			
Port A	General I/O port also functioning as SCI_2 I/O pins and address bus output pins	PA3/A19/SCK2 PA2/A18/RxD2 PA1/A17/TxD2 PA0/A16		PA3/SCK2 PA2/RxD2 PA1/TxD2 PA0	On-chip input pull-up MOS Open-drain output
Port B	General I/O port also functioning as address bus output pins	PB7/A15 PB6/A14 PB5/A13 PB4/A12 PB3/A11 PB2/A10 PB1/A9 PB0/A8		PB7 PB6 PB5 PB4 PB3 PB2 PB1 PB0	On-chip input pull-up MOS
Port C	General I/O port also functioning as address bus output pins	A7 A6 A5 A4 A3 A2 A1 A0	When DDR = 0: PC7 When DDR = 1: A7  When DDR = 0: PC6 When DDR = 1: A6  When DDR = 0: PC5 When DDR = 1: A5  When DDR = 0: PC4 When DDR = 1: A4  When DDR = 0: PC73 When DDR = 1: A3  When DDR = 0: PC2 When DDR = 1: A2  When DDR = 0: PC1 When DDR = 1: A1  When DDR = 0: PC0 When DDR = 1: A0	PC7 PC6 PC5 PC4 PC3 PC2 PC1 PC0	On-chip input pull-up MOS
Port D	General I/O port also functioning as data bus I/O pins	D15 D14 D13 D12 D11 D10 D9 D8		PD7 PD6 PD5 PD4 PD3 PD2 PD1 PD0	On-chip input pull-up MOS

Port	Description	Modes 4 and 5	Mode 6	Mode 7	Input/Output Type
Port E	General I/O port also functioning as data bus I/O pins	8-bit bus mode: PE7		PE7	On-chip input pull-up MOS
		16-bit bus mode: D7			
		8-bit bus mode: PE6		PE6	
		16-bit bus mode: D6			
		8-bit bus mode: PE5		PE5	
		16-bit bus mode: D5			
		8-bit bus mode: PE4		PE4	
		16-bit bus mode: D4			
		8-bit bus mode: PE3		PE3	
		16-bit bus mode: D3			
		8-bit bus mode: PE2		PE2	
		16-bit bus mode: D2			
		8-bit bus mode: PE1		PE1	
		16-bit bus mode: D1			
		8-bit bus mode: PE0		PE0	
		16-bit bus mode: D0			
Port F	General I/O port also functioning as bus control signal I/O pins and interrupt input pins	When DDR = 0: PF7		When DDR = 0 (after reset): PF7	Schmitt trigger input ( $\overline{IRQ3}$ , $\overline{IRQ2}$ )
		When DDR = 1 (after reset): $\phi$		When DDR = 1: $\phi$	
		$\overline{AS}$		PF6	
		$\overline{RD}$		PF5	
		$\overline{HWR}$		PF4	
		8-bit bus mode: PF3/ADTRG/ $\overline{IRQ3}$		PF3/ADTRG/ $\overline{IRQ3}$	
		16-bit bus mode: $\overline{LWR}$			
		When WAITE = 0 (after reset): PF2		PF2	
		When WAITE = 1: $\overline{WAIT}$			
		When BRLE = 0 (after reset): PF1		PF1	
		When BRLE = 1: $\overline{BACK}$			
When BRLE = 0 (after reset): PF0/ $\overline{IRQ2}$		PF0/ $\overline{IRQ2}$			
When BRLE = 1: $\overline{BREQ}/\overline{IRQ2}$					

Port	Description	Modes 4 and 5	Mode 6	Mode 7	Input/Output Type
Port G	General I/O port also functioning as bus control output pins and interrupt input pins	When DDR = 0 (after reset in mode 6): PG4		PG4	Schmitt trigger input ( $\overline{\text{IRQ7}}$ )
		When DDR = 1 (after reset in modes 4, 5): $\overline{\text{CS0}}$			
		When DDR = 0: PG3		PG3	
		When DDR = 1: $\overline{\text{CS1}}$			
		When DDR = 0: PG2		PG2	
		When DDR = 1: $\overline{\text{CS2}}$			
		When DDR = 0: PG1/ $\overline{\text{IRQ7}}$		PG1/ $\overline{\text{IRQ7}}$	
		When DDR = 1: $\overline{\text{CS3}}$ / $\overline{\text{IRQ7}}$			

Table 8.2 Port Functions of H8S/2212 Group

Port	Description	Mode 7	Input/Output Type
Port 1	General I/O port also functioning as TPU I/O pins and interrupt input pins	P17/TIOCB2/TCLKD	Schmitt trigger input ( $\overline{\text{IRQ1}}$ , $\overline{\text{IRQ0}}$ )
		P16/TIOCA2/ $\overline{\text{IRQ1}}$	
		P15/TIOCB1/TCLKC	
		P14/TIOCA1/ $\overline{\text{IRQ0}}$	
		P13/TIOCD0/TCLKB	
		P12/TIOCC0/TCLKA	
		P11/TIOCB0	
P10/TIOCA0			
Port 3	General I/O port also functioning as SCI_0 I/O pins and interrupt input pins	P36	Open-drain output Schmitt trigger input ( $\overline{\text{IRQ4}}$ )
		P32/SCK0/ $\overline{\text{IRQ4}}$	
		P31/RxD0	
		P30/TxD0	
Port 4	General input port also functioning as A/D converter analog input pins	P43/AN3	
		P42/AN2	
		P41/AN1	
		P40/AN0	
Port 7	General I/O port	P77*	
		P76*	
		P75*	
Port 9	General input port also functioning as A/D converter analog input pins	P97/AN15	
		P96/AN14	

Port	Description	Mode 7	Input/Output Type
Port A	General I/O port also functioning as SCI_2 I/O pins	PA3/SCK2 PA2/RxD2 PA1/TxD2	On-chip input pull-up MOS Open-drain output
Port E	General I/O port	PE7 PE6 PE5 PE4 PE3 PE2 PE1 PE0	On-chip input pull-up MOS
Port F	General I/O port also functioning as interrupt input pins	When DDR = 0 (after reset): PF7 When DDR = 1: $\phi$ PF3/ADTRG/IRQ3 PF0/IRQ2	Schmitt trigger input ( $\overline{\text{IRQ3}}$ , $\overline{\text{IRQ2}}$ )
Port G	General I/O port also functioning as interrupt input pins	PG1/ $\overline{\text{IRQ7}}$ PG0*	Schmitt trigger input ( $\overline{\text{IRQ7}}$ )

Note: \* These pins are available only when EMLE = 0. These pins are not available when the H-UDI is used.

## 8.1 Port 1

In the H8S/2218 Group, the port 1 is an 8-bit I/O port also functioning as address bus pins, TPU I/O pins, and external interrupt input pins. In the H8S/2212 Group, the port 1 is an 8-bit I/O port also functioning as TPU I/O pins and external interrupt input pins. The port 1 has the following registers.

- Port 1 data direction register (P1DDR)
- Port 1 data register (P1DR)
- Port 1 register (PORT1)

### 8.1.1 Port 1 Data Direction Register (P1DDR)

P1DDR specifies input or output for the pins of the port 1.

Since P1DDR is a write-only register, the bit manipulation instructions must not be used to write P1DDR. For details, see section 2.9.4, Accessing Registers Containing Write-Only Bits.

Bit	Bit Name	Initial Value	R/W	Description
7	P17DDR	0	W	(H8S/2218 Group)
6	P16DDR	0	W	Modes 4 to 6:
5	P15DDR	0	W	If address output is enabled by the setting of bits AE3 to AE0 in PFCR, pins P13 to P10 are address outputs. Pins P17 to P14, and pins P13 to P10 when address output is disabled, are output ports when the corresponding P1DDR bits are set to 1, and input ports when the corresponding P1DDR bits are cleared to 0.
4	P14DDR	0	W	
3	P13DDR	0	W	
2	P12DDR	0	W	
1	P11DDR	0	W	
0	P10DDR	0	W	Mode 7: Setting a P1DDR bit to 1 makes the corresponding port 1 pin an output port, while clearing the bit to 0 makes the pin an input port. (H8S/2212 Group) Setting a P1DDR bit to 1 makes the corresponding port 1 pin an output port, while clearing the bit to 0 makes the pin an input port.



### 8.1.2 Port 1 Data Register (P1DR)

P1DR stores output data for the port 1 pins.

Bit	Bit Name	Initial Value	R/W	Description
7	P17DR	0	R/W	Store output data for a pin that functions as a general output port.
6	P16DR	0	R/W	
5	P15DR	0	R/W	
4	P14DR	0	R/W	
3	P13DR	0	R/W	
2	P12DR	0	R/W	
1	P11DR	0	R/W	
0	P10DR	0	R/W	

### 8.1.3 Port 1 Register (PORT1)

PORT1 indicates the pin states of the port 1.

Bit	Bit Name	Initial Value	R/W	Description
7	P17	—*	R	If the port 1 is read while P1DDR bits are set to 1, the P1DR value is read. If the port 1 is read while P1DDR bits are cleared to 0, the pin states are read.
6	P16	—*	R	
5	P15	—*	R	
4	P14	—*	R	
3	P13	—*	R	
2	P12	—*	R	
1	P11	—*	R	
0	P10	—*	R	

Note: \* Determined by the states of pins P17 to P10.

### 8.1.4 Pin Functions

#### Pin Functions of H8S/2218 Group

Port 1 pins also function as address bus (A23 to A20) output pins, TPU I/O pins, and external interrupt input ( $\overline{\text{IRQ0}}$  and  $\overline{\text{IRQ1}}$ ) pins. The correspondence between the register specification and the pin functions is shown below.

**Table 8.3 P17 Pin Function**

TPU Channel 2 Setting*	Output Setting	Input Setting or Initial Value	
P17DDR	—	0	1
Pin Function	TIOCB2 output pin	P17 input pin	P17 output pin
		TIOCB2 input pin	
	TCLKD input pin		

Note: \* For details on the TPU channel setting, refer to section 9, 16-Bit Timer Pulse Unit (TPU).

**Table 8.4 P16 Pin Function**

TPU Channel 2 Setting* <sup>1</sup>	Output Setting	Input Setting or Initial Value	
P16DDR	—	0	1
Pin Function	TIOCA2 output pin	P16 input pin	P16 output pin
		TIOCA2 input pin	
	$\overline{\text{IRQ1}}$ input pin* <sup>2</sup>		

Notes: 1. For details on the TPU channel setting, refer to section 9, 16-Bit Timer Pulse Unit (TPU).

2. When this pin is used as an external interrupt pin, this pin must not be used for another function.

**Table 8.5 P15 Pin Function**

TPU Channel 1 Setting*	Output Setting	Input Setting or Initial Value	
P15DDR	—	0	1
Pin Function	TIOCB1 output pin	P15 input pin	P15 output pin
		TIOCB1 input pin	
	TCLKC input pin		

Note: \* For details on the TPU channel setting, refer to section 9, 16-Bit Timer Pulse Unit (TPU).

**Table 8.6 P14 Pin Function**

TPU Channel 1 Setting* <sup>1</sup>	Output Setting	Input Setting or Initial Value	
P14DDR	—	0	1
Pin Function	TIOCA1 output pin	P14 input pin	P14 output pin
		TIOCA1 input pin	
	IRQ0 input pin* <sup>2</sup>		

- Notes: 1. For details on the TPU channel setting, refer to section 9, 16-Bit Timer Pulse Unit (TPU).
2. When this pin is used as an external interrupt pin, this pin must not be used for another function.

**Table 8.7 P13 Pin Function**

AE3 to AE0* <sup>2</sup>	Other than B'1111			B'1111
TPU Channel 0 Setting* <sup>1</sup>	Output Setting	Input Setting or Initial Value		—
P13DDR	—	0	1	—
Pin Function	TIOCD0 output pin	P13 input pin	P13 output pin	A23 output pin* <sup>2</sup>
		TIOCD0 input pin		
	TCLKB input pin			

- Notes: 1. For details on the TPU channel setting, refer to section 9, 16-Bit Timer Pulse Unit (TPU).
2. Valid in modes 4, 5, and 6.

**Table 8.8 P12 Pin Function**

AE3 to AE0* <sup>2</sup>	Other than B'1111			B'1111
TPU Channel 0 Setting* <sup>1</sup>	Output Setting	Input Setting or Initial Value		—
P12DDR	—	0	1	—
Pin Function	TIOCC0 output pin	P12 input pin	P12 output pin	A22 output pin* <sup>2</sup>
		TIOCC0 input pin		
	TCLKA input pin			

- Notes: 1. For details on the TPU channel setting, refer to section 9, 16-Bit Timer Pulse Unit (TPU).
2. Valid in modes 4, 5, and 6.

**Table 8.9 P11 Pin Function**

AE3 to AE0* <sup>2</sup>	Other than B'1110 to B'1111			B'1110 to B'1111
TPU Channel 0 Setting* <sup>1</sup>	Output Setting	Input Setting or Initial Value		—
P11DDR	—	0	1	—
Pin Function	TIOCB0 output pin	P11 input pin	P11 output pin	A21 output pin* <sup>2</sup>
		TIOCB0 input pin		

Notes: 1. For details on the TPU channel setting, refer to section 9, 16-Bit Timer Pulse Unit (TPU).

2. Valid in modes 4, 5, and 6.

**Table 8.10 P10 Pin Function**

AE3 to AE0* <sup>2</sup>	Other than B'1101 to B'1111			B'1101 to B'1111
TPU Channel 0 Setting* <sup>1</sup>	Output Setting	Input Setting or Initial Value		—
P10DDR	—	0	1	—
Pin Function	TIOCA0 output pin	P10 input pin	P10 output pin	A20 output pin* <sup>2</sup>
		TIOCA0 input pin		

Notes: 1. For details on the TPU channel setting, refer to section 9, 16-Bit Timer Pulse Unit (TPU).

2. Valid in modes 4, 5, and 6.

### Pin Functions of H8S/2212 Group

Port 1 pins also function as TPU I/O pins and external interrupt input ( $\overline{\text{IRQ0}}$  and  $\overline{\text{IRQ1}}$ ) pins. The correspondence between the register specification and the pin functions is shown below.

**Table 8.11 P17 Pin Function**

TPU Channel 2 Setting*	Output Setting	Input Setting or Initial Value	
P17DDR	—	0	1
Pin Function	TIOCB2 output pin	P17 input pin	P17 output pin
		TIOCB2 input pin	
	TCLKD input pin		

Note: \* For details on the TPU channel setting, refer to section 9, 16-Bit Timer Pulse Unit (TPU).

**Table 8.12 P16 Pin Function**

TPU Channel 2 Setting* <sup>1</sup>	Output Setting	Input Setting or Initial Value	
P16DDR	—	0	1
Pin Function	TIOCA2 output pin	P16 input pin	P16 output pin
		TIOCA2 input pin	
	$\overline{\text{IRQ1}}$ input pin* <sup>2</sup>		

Notes: 1. For details on the TPU channel setting, refer to section 9, 16-Bit Timer Pulse Unit (TPU).

2. When this pin is used as an external interrupt pin, this pin must not be used for another function.

**Table 8.13 P15 Pin Function**

TPU Channel 1 Setting*	Output Setting	Input Setting or Initial Value	
P15DDR	—	0	1
Pin Function	TIOCB1 output pin	P15 input pin	P15 output pin
		TIOCB1 input pin	
	TCLKC input pin		

Note: \* For details on the TPU channel setting, refer to section 9, 16-Bit Timer Pulse Unit (TPU).

**Table 8.14 P14 Pin Function**

TPU Channel 1 Setting* <sup>1</sup>	Output Setting	Input Setting or Initial Value	
P14DDR	—	0	1
Pin Function	TIOCA1 output pin	P14 input pin	P14 output pin
		TIOCA1 input pin	
	$\overline{\text{IRQ0}}$ input pin* <sup>2</sup>		

Notes: 1. For details on the TPU channel setting, refer to section 9, 16-Bit Timer Pulse Unit (TPU).

2. When this pin is used as an external interrupt pin, this pin must not be used for another function.

**Table 8.15 P13 Pin Function**

TPU Channel 0 Setting*	Output Setting	Input Setting or Initial Value	
P13DDR	—	0	1
Pin Function	TIOCD0 output pin	P13 input pin	P13 output pin
		TIOCD0 input pin	
	TCLKB input pin		

Note: \* For details on the TPU channel setting, refer to section 9, 16-Bit Timer Pulse Unit (TPU).

**Table 8.16 P12 Pin Function**

TPU Channel 0 Setting*	Output Setting	Input Setting or Initial Value	
P12DDR	—	0	1
Pin Function	TIOCC0 output pin	P12 input pin	P12 output pin
		TIOCC0 input pin	
	TCLKA input pin		

Note: \* For details on the TPU channel setting, refer to section 9, 16-Bit Timer Pulse Unit (TPU).

**Table 8.17 P11 Pin Function**

TPU Channel 0 Setting*	Output Setting	Input Setting or Initial Value	
P11DDR	—	0	1
Pin Function	TIOCB0 output pin	P11 input pin	P11 output pin
		TIOCB0 input pin	

Note: \* For details on the TPU channel setting, refer to section 9, 16-Bit Timer Pulse Unit (TPU).

**Table 8.18 P10 Pin Function**

TPU Channel 0 Setting*	Output Setting	Input Setting or Initial Value	
P10DDR	—	0	1
Pin Function	TIOCA0 output pin	P10 input pin	P10 output pin
		TIOCA0 input pin	

Note: \* For details on the TPU channel setting, refer to section 9, 16-Bit Timer Pulse Unit (TPU).

## 8.2 Port 3

The port 3 is a 4-bit I/O port also functioning as the SCI I/O pins and external interrupt input ( $\overline{\text{IRQ4}}$ ) pins. The port 3 of the H8S/2218 Group has the same function as that of the H8S/2212 Group. The port 3 has the following registers.

- Port 3 data direction register (P3DDR)
- Port 3 data register (P3DR)
- Port 3 register (PORT3)
- Port 3 open-drain control register (P3ODR)

### 8.2.1 Port 3 Data Direction Register (P3DDR)

P3DDR specifies input or output for the pins of the port 3.

Since P3DDR is a write-only register, the bit manipulation instructions must not be used to write P3DDR. For details, see section 2.9.4, Accessing Registers Containing Write-Only Bits.

Bit	Bit Name	Initial Value	R/W	Description
7	—	Undefined	—	Reserved This bit is undefined and cannot be modified.
6	P36DDR	0	W	Setting a P3DDR bit to 1 makes the corresponding port 3 pin an output pin, while clearing the bit to 0 makes the pin an input pin.
5 to 3	—	Undefined	—	Reserved These bits are undefined and cannot be modified.
2	P32DDR	0	W	Setting a P3DDR bit to 1 makes the corresponding port 3 pin an output pin, while clearing the bit to 0 makes the pin an input pin.
1	P31DDR	0	W	
0	P30DDR	0	W	

### 8.2.2 Port 3 Data Register (P3DR)

P3DR stores output data for the port 3 pins.

Bit	Bit Name	Initial Value	R/W	Description
7	—	Undefined	—	Reserved This bit is undefined and cannot be modified.
6	P36DR	0	R/W	Stores output data for a pin that functions as a general output port.
5 to 3	—	Undefined	—	Reserved These bits are undefined and cannot be modified.
2	P32DR	0	R/W	Store output data for a pin that functions as a general output port.
1	P31DR	0	R/W	
0	P30DR	0	R/W	

### 8.2.3 Port 3 Register (PORT3)

PORT3 indicates the pin states of the port 3.

Bit	Bit Name	Initial Value	R/W	Description
7	—	Undefined	—	Reserved This bit is undefined.
6	P36	—*	R	If the port 3 is read while P3DDR bits are set to 1, the P3DR value is read. If the port 3 is read while P3DDR bits are cleared to 0, the pin states are read.
5 to 3	—	Undefined	—	Reserved These bits are undefined.
2	P32	—*	R	If the port 3 is read while P3DDR bits are set to 1, the P3DR value is read. If the port 3 is read while P3DDR bits are cleared to 0, the pin states are read.
1	P31	—*	R	
0	P30	—*	R	

Note: \* Determined by the states of pins P36 and P32 to P30.



### 8.2.4 Port 3 Open-Drain Control Register (P3ODR)

P3ODR controls the PMOS on/off state for each port 3 pin.

Bit	Bit Name	Initial Value	R/W	Description
7	—	Undefined	—	Reserved This bit is undefined and cannot be modified.
6	P36ODR	0	R/W	Setting a P3ODR bit to 1 makes the corresponding port 3 pin an NMOS open-drain output pin, while clearing the bit to 0 makes the pin a CMOS output pin.
5 to 3	—	Undefined	—	Reserved These bits are undefined and cannot be modified.
2	P32ODR	0	R/W	Setting a P3ODR bit to 1 makes the corresponding port 3 pin an NMOS open-drain output pin, while clearing the bit to 0 makes the pin a CMOS output pin.
1	P31ODR	0	R/W	
0	P30ODR	0	R/W	

### 8.2.5 Pin Functions

Port 3 pins also function as SCI I/O pins and external interrupt input ( $\overline{\text{IRQ4}}$ ) pins. The correspondence between the register specification and the pin functions is shown below. The P36 pin must be used as the D+ pull-up control output pin of the USB. For details, refer to section 14, Universal Serial Bus (USB).

**Table 8.19 P36 Pin Function**

P36DDR	0	1
Pin Function	P36 input pin	P36 output pin (D+ pull-up control output pin of USB)

**Table 8.20 P32 Pin Function**

CKE1 in SCR_0	0			1	
C/ $\bar{A}$ in SMR_0	0		1	—	
CKE0 in SCR_0	0	1	—	—	
P32DDR	0	1	—	—	—
Pin Function	P32 input pin	P32 output pin	SCK0 output pin	SCK0 output pin	SCK0 input pin
	$\bar{I}RQ4$ input pin*				

Note: \*When this pin is used as an external interrupt pin, this pin must not be used for another function.

**Table 8.21 P31 Pin Function**

RE in SCR_0	0		1
P31DDR	0	1	—
Pin Function	P31 input pin	P31 output pin	RxD0 input pin

**Table 8.22 P30 Pin Function**

TE in SCR_0	0		1
P30DDR	0	1	—
Pin Function	P30 input pin	P30 output pin	TxD0 output pin

## 8.3 Port 4

The port 4 is a 4-bit input port also functioning as A/D converter analog input pins. The port 4 of the H8S/2218 Group has the same function as that of the H8S/2212 Group. The port 4 has the following register.

- Port 4 register (PORT4)

### 8.3.1 Port 4 Register (PORT4)

PORT4 indicates the pin states of the port 4.

Bit	Bit Name	Initial Value	R/W	Description
7 to 4	—	Undefined	—	Reserved These bits are undefined.
3	P43	—*	R	The pin states are always read when these bits are read.
2	P42	—*	R	
1	P41	—*	R	
0	P40	—*	R	

Note: \* Determined by the states of pins P43 to P40.

### 8.3.2 Pin Function

The port 4 also functions as A/D converter analog input (AN3 to AN0) pins.

## 8.4 Port 7

In the H8S/2218 Group, the port 7 is a 3-bit I/O port also functioning as bus control output pins and manual reset input pins. In the H8S/2212 Group, the port 7 is a 3-bit I/O port also functioning as H-UDI pins. The port 7 has the following registers.

- Port 7 data direction register (P7DDR)
- Port 7 data register (P7DR)
- Port 7 register (PORT7)

### 8.4.1 Port 7 Data Direction Register (P7DDR)

P7DDR specifies input or output for the pins of the port 7.

Since P7DDR is a write-only register, the bit manipulation instructions must not be used to write P7DDR. For details, see section 2.9.4, Accessing Registers Containing Write-Only Bits.

Bit	Bit Name	Initial Value	R/W	Description
7	P77DDR	0	W	(H8S/2218 Group)
6	P76DDR	0	W	Reserved
5	P75DDR	0	W	These bits are undefined and cannot be modified. (H8S/2212 Group) When EMLE = 1: Pins P77 to P75 function as the H-UDI pins (TDO, TMS, TCK). When EMLE = 0: If a P7DDR bit is set to 1, pins P77 to P75 function as output ports. If a P7DDR bit is cleared to 0, pins P77 to P75 function as input ports.
4	P74DDR	0	W	(H8S/2218 Group) Setting a P7DDR bit to 1 makes the corresponding port 7 pin an output pin, while clearing the bit to 0 makes the pin an input pin. (H8S/2212 Group) Reserved This bit is undefined and cannot be modified.
3, 2	—	Undefined	—	Reserved These bits are undefined and cannot be modified.

Bit	Bit Name	Initial Value	R/W	Description
1	P71DDR	0	W	(H8S/2218 Group)
0	P70DDR	0	W	Setting a P7DDR bit to 1 makes the corresponding port 7 pin an output pin, while clearing the bit to 0 makes the pin an input pin. (H8S/2212 Group) Reserved These bits are undefined and cannot be modified.

#### 8.4.2 Port 7 Data Register (P7DR)

P7DR stores output data for the port 7 pins.

Bit	Bit Name	Initial Value	R/W	Description
7	P77DR	0	R/W	(H8S/2218 Group)
6	P76DR	0	R/W	Reserved
5	P75DR	0	R/W	These bits are undefined and cannot be modified. (H8S/2212 Group) Store output data for the port 7 pins.
4	P74DR	0	R/W	(H8S/2218 Group) Stores output data for the port 7 pins. (H8S/2212 Group) Reserved This bit is undefined and cannot be modified.
3, 2	—	Undefined	—	Reserved These bits are undefined and cannot be modified.
1	P71DR	0	R/W	(H8S/2218 Group)
0	P70DR	0	R/W	Store output data for the port 7 pins. (H8S/2212 Group) Reserved These bits are undefined and cannot be modified.

### 8.4.3 Port 7 Register (PORT7)

PORT7 indicates the pin states of the port 7.

Bit	Bit Name	Initial Value	R/W	Description
7	P77	—*	—	(H8S/2218 Group)
6	P76	—*	—	Reserved
5	P75	—*	—	These bits are undefined and cannot be modified. (H8S/2212 Group) If P7DDR bits are set to 1, the P7DR value is read. If P7DDR bits are cleared to 0, the pin states are read.
4	P74	—*	R	(H8S/2218 Group) If the port 7 is read while P7DDR bits are set to 1, the P7DR value is read. If the port 7 is read while P7DDR bits are cleared to 0, the pin states are read. (H8S/2212 Group) Reserved This bit is undefined and cannot be modified.
3, 2	—	Undefined	—	Reserved These bits are undefined and cannot be modified.
1	P71	—*	R	(H8S/2218 Group)
0	P70	—*	R	If the port 7 is read while P7DDR bits are set to 1, the P7DR value is read. If the port 7 is read while P7DDR bits are cleared to 0, the pin states are read. (H8S/2212 Group) Reserved These bits are undefined and cannot be modified.

Note: \* Determined by the states of pins P77 to P74, P71, and P70.

## 8.4.4 Pin Functions

### Pin Functions of H8S/2218 Group

Port 7 pins also function as bus control output pins and manual reset input pins. The correspondence between the register specification and the pin functions is shown below.

**Table 8.23 P74 Pin Function**

MRESE	0		1
P74DDR	0	1	—
Pin Function	P74 input pin	P74 output pin	$\overline{\text{MRES}}$ input pin

**Table 8.24 P71 Pin Function**

Operating Mode	Modes 4 to 6		Mode 7	
P71DDR	0	1	0	1
Pin Function	P71 input pin	$\overline{\text{CS5}}$ output pin	P71 input pin	P71 output pin

**Table 8.25 P70 Pin Function**

Operating Mode	Modes 4 to 6		Mode 7	
P70DDR	0	1	0	1
Pin Function	P70 input pin	$\overline{\text{CS4}}$ output pin	P70 input pin	P70 output pin

### Pin Functions of H8S/2212 Group

Port 7 pins also function as H-UDI pins. The correspondence between the register specification and the pin functions is shown below.

**Table 8.26 P77 Pin Function**

EMLE	0		1
P77DDR	0	1	—
Pin Function	P77 input pin	P77 output pin	TDO output pin

**Table 8.27 P76 Pin Function**

EMLE	0		1
P76DDR	0	1	—
Pin Function	P76 input pin	P76 output pin	TCK input pin

**Table 8.28 P75 Pin Function**

EMLE	0		1
P75DDR	0	1	—
Pin Function	P75 input pin	P75 output pin	TMS input pin

## 8.5 Port 9

The port 9 is a 2-bit input port also functioning as A/D converter analog input pins. The port 9 of the H8S/2218 Group has the same function as that of the H8S/2212 Group.

- Port 9 register (PORT9)

### 8.5.1 Port 9 Register (PORT9)

PORT9 indicates the pin states of the port 9.

Bit	Bit Name	Initial Value	R/W	Description
7	P97	—*	R	The pin states are always read when these bits are read.
6	P96	—*	R	
5 to 0	—	Undefined	—	Reserved These bits are undefined.

Note: \* Determined by the states of pins P97 and P96.

### 8.5.2 Pin Function

The port 9 also functions as A/D converter analog input (AN15 and AN14) pins.



## 8.6 Port A

In the H8S/2218 Group, the port A is a 4-bit I/O port also functioning as address bus (A19 to A16) output pins and SCI I/O pins. In the H8S/2212 Group, the port A is a 3-bit I/O port also functioning as SCI I/O pins. The port A has the following registers.

- Port A data direction register (PADDR)
- Port A data register (PADR)
- Port A register (PORTA)
- Port A pull-up MOS control register (PAPCR)
- Port A open-drain control register (PAODR)

### 8.6.1 Port A Data Direction Register (PADDR)

PADDR specifies input or output for the pins of the port A.

Since PADDR is a write-only register, the bit manipulation instructions must not be used to write PADDR. For details, see section 2.9.4, Accessing Registers Containing Write-Only Bits.

Bit	Bit Name	Initial Value	R/W	Description
7 to 4	—	Undefined	—	Reserved These bits are undefined and cannot be modified.
3	PA3DDR	0	W	(H8S/2218 Group)
2	PA2DDR	0	W	Modes 4 to 6:
1	PA1DDR	0	W	If address output is enabled by the setting of bits AE3 to AE0 in PFCR, the corresponding port A pins are address outputs. When address output is disabled, setting a PADDR bit to 1 makes the corresponding port A pin an output port, while clearing the bit to 0 makes the pin an input port.
0	PA0DDR*	0	W	Mode 7: Setting a PADDR bit to 1 makes the corresponding port A pin an output port, while clearing the bit to 0 makes the pin an input port. (H8S/2212 Group) Setting a PADDR bit to 1 makes the corresponding port A pin an output port, while clearing the bit to 0 makes the pin an input port.

Note: \* Reserved in the H8S/2212 Group. If this bit is read, an undefined value will be read. This bit cannot be modified.

### 8.6.2 Port A Data Register (PADR)

PADR stores output data for the port A pins.

Bit	Bit Name	Initial Value	R/W	Description
7 to 4	—	Undefined	—	Reserved These bits are undefined and cannot be modified.
3	PA3DR	0	R/W	Store output data for a pin that functions as a general output port.
2	PA2DR	0	R/W	
1	PA1DR	0	R/W	
0	PA0DR*	0	R/W	

Note: \* Reserved in the H8S/2212 Group. If this bit is read, an undefined value will be read. This bit cannot be modified.

### 8.6.3 Port A Register (PORTA)

PORTA indicates the pin states of the port A.

Bit	Bit Name	Initial Value	R/W	Description
7 to 4	—	Undefined	—	Reserved These bits are undefined.
3	PA3	—* <sup>1</sup>	R	If the port A is read while PADDR bits are set to 1, the PADR value is read. If the port A is read while PADDR bits are cleared to 0, the pin states are read.
2	PA2	—* <sup>1</sup>	R	
1	PA1	—* <sup>1</sup>	R	
0	PA0* <sup>2</sup>	—* <sup>1</sup>	R	

Notes: 1. Determined by the states of pins PA3 to PA0.

2. Reserved in the H8S/2212 Group. If this bit is read, an undefined value will be read.

### 8.6.4 Port A Pull-Up MOS Control Register (PAPCR)

PAPCR controls the on/off state of the port A input pull-up MOS. PAPCR is valid for port input and SCI input pins.

Bit	Bit Name	Initial Value	R/W	Description
7 to 4	—	Undefined	—	Reserved These bits are undefined and cannot be modified.
3	PA3PCR	0	R/W	When a pin functions as an input port, setting the corresponding bit to 1 turns on the input pull-up MOS for that pin.
2	PA2PCR	0	R/W	
1	PA1PCR	0	R/W	
0	PA0PCR*	0	R/W	

Note: \* Reserved in the H8S/2212 Group. If this bit is read, an undefined value will be read. This bit cannot be modified.

### 8.6.5 Port A Open-Drain Control Register (PAODR)

PAODR specifies an output type of the port A. PAODR is valid for port output and SCI output pins.

Bit	Bit Name	Initial Value	R/W	Description
7 to 4	—	Undefined	—	Reserved These bits are undefined and cannot be modified.
3	PA3ODR	0	R/W	Setting a PAODR bit to 1 makes the corresponding port A pin an NMOS open-drain output pin, while clearing the bit to 0 makes the pin a CMOS output pin.
2	PA2ODR	0	R/W	
1	PA1ODR	0	R/W	
0	PA0ODR*	0	R/W	

Note: \* Reserved in the H8S/2212 Group. If this bit is read, an undefined value will be read. This bit cannot be modified.

## 8.6.6 Pin Functions

### Pin Functions of H8S/2218 Group

Port A pins also function as address bus (A19 to A16) output pins and SCI\_2 I/O pins. The correspondence between the register specification and the pin functions is shown below.

**Table 8.29 PA3 Pin Function**

Operating Mode	Modes 4 to 6						Mode 7					
AE3 to AE0	B'11xx	Other than B'11xx						—				
CKE1 in SCR_2	—	0				1	0			1		
C/ $\bar{A}$ in SMR_2	—	0			1	—	0		1	—		
CKE0 in SCR_2	—	0		1	—	—	0		1	—	—	
PA3DDR	—	0	1	—	—	—	0	1	—	—	—	
Pin Function	A19 output pin	PA3 input pin	PA3 output pin	SCK2 output pin	SCK2 output pin	SCK2 input pin	PA3 input pin	PA3 output pin	SCK2 output pin	SCK2 output pin	SCK2 input pin	

**Table 8.30 PA2 Pin Function**

Operating mode	Modes 4 to 6					Mode 7			
AE3 to AE0	B'1011 or B'11xx	Other than B'1011 or B'11xx					—		
RE in SCR_2	—	0			1	0		1	
PA2DDR	—	0	1	—	0	1	—		
Pin Function	A18 output pin	PA2 input pin	PA2 output pin	RxD2 input pin	PA2 input pin	PA2 output pin	RxD2 input pin		

Legend:

x: Don't care.

**Table 8.31 PA1 Pin Function**

Operating mode	Modes 4 to 6				Mode 7		
AE3 to AE0	B'101× or B'11××	Other than B'101× or B'11××			—		
TE in SCR_2	—	0		1	0		1
PA1DDR	—	0	1	—	0	1	—
Pin Function	A17 output pin	PA1 input pin	PA1 output pin	TxD2 output pin	PA1 input pin	PA1 output pin	TxD2 output pin

**Table 8.32 PA0 Pin Function**

Operating mode	Modes 4 to 6			Mode 7	
AE3 to AE0	Other than B'0××× or B'1000	B'0××× or B'1000		—	
PA0DDR	—	0	1	0	1
Pin Function	A16 output pin	PA0 input pin	PA0 output pin	PA0 input pin	PA0 output pin

Legend:

x: Don't care.

**Pin Functions of H8S/2212 Group**

Port A pins also function as SCI\_2 I/O pins. The correspondence between the register specification and the pin functions is shown below.

**Table 8.33 PA3 Pin Function**

CKE1 in SCR_2	0			1	
C/A in SMR_2	0			1	—
CKE0 in SCR_2	0		1	—	—
PA3DDR	0	1	—	—	—
Pin Function	PA3 input pin	PA3 output pin	SCK2 output pin	SCK2 output pin	SCK2 input pin

**Table 8.34 PA2 Pin Function**

RE in SCR_2	0		1
PA2DDR	0	1	—
Pin Function	PA2 input pin	PA2 output pin	RxD2 input pin

**Table 8.35 PA1 Pin Function**

TE in SCR_2	0		1
PA1DDR	0	1	—
Pin Function	PA1 input pin	PA1 output pin	TxD2 output pin

### 8.6.7 Port A Input Pull-Up MOS States

The port A has an on-chip input pull-up MOS function that can be controlled by software. The input pull-up MOS can be specified as the on or off state for individual bits.

Table 8.36 summarizes the input pull-up MOS states.

**Table 8.36 Input Pull-Up MOS States (Port A)**

Pins	Power-On Reset	Hardware Standby Mode	Manual Reset	Software Standby Mode	In Other Operations
Address output, port output, SCI output	Off		Off		
Port input, SCI input			On/Off		

Legend:

Off: Input pull-up MOS is always off.

On/Off: On when PADDR = 0 and PAPCR = 1; otherwise off.

## 8.7 Port B (H8S/2218 Group Only)

The port B is an 8-bit I/O port also functioning as address bus (A15 to A8) output pins. The port B has the following registers.

Note: When the USB is used while the E6000 emulator is used, the AE3 to AE0 bits in PFCR must be set so that the PB1 and PB0 pins output addresses A9 and A8. This note applies to both the H8S/2218 Group and H8S/2212 Group.

- Port B data direction register (PBDDR)
- Port B data register (PBDR)
- Port B register (PORTB)
- Port B pull-up MOS control register (PBPCR)

### 8.7.1 Port B Data Direction Register (PBDDR)

PBDDR specifies input or output for the pins of the port B.

Since PBDDR is a write-only register, the bit manipulation instructions must not be used to write PBDDR. For details, see section 2.9.4, Accessing Registers Containing Write-Only Bits.

Bit	Bit Name	Initial Value	R/W	Description
7	PB7DDR	0	W	Modes 4 to 6:
6	PB6DDR	0	W	If address output is enabled by the setting of bits AE3 to AE0 in PFCR, the corresponding port B pins are address outputs. When address output is disabled, setting a PBDDR bit to 1 makes the corresponding port B pin an output port, while clearing the bit to 0 makes the pin an input port.
5	PB5DDR	0	W	
4	PB4DDR	0	W	
3	PB3DDR	0	W	
2	PB2DDR	0	W	Mode 7: Setting a PBDDR bit to 1 makes the corresponding port B pin an output port, while clearing the bit to 0 makes the pin an input port.
1	PB1DDR	0	W	
0	PB0DDR	0	W	

### 8.7.2 Port B Data Register (PBDR)

PBDR stores output data for the port B pins.

Bit	Bit Name	Initial Value	R/W	Description
7	PB7DR	0	R/W	Store output data for a pin that functions as a general output port.
6	PB6DR	0	R/W	
5	PB5DR	0	R/W	
4	PB4DR	0	R/W	
3	PB3DR	0	R/W	
2	PB2DR	0	R/W	
1	PB1DR	0	R/W	
0	PB0DR	0	R/W	

### 8.7.3 Port B Register (PORTB)

PORTB indicates the pin states of the port B.

Bit	Bit Name	Initial Value	R/W	Description
7	PB7	—*	R	If the port B is read while PBDDR bits are set to 1, the PBDR value is read. If the port B is read while PBDDR bits are cleared to 0, the pin states are read.
6	PB6	—*	R	
5	PB5	—*	R	
4	PB4	—*	R	
3	PB3	—*	R	
2	PB2	—*	R	
1	PB1	—*	R	
0	PB0	—*	R	

Note: \* Determined by the states of pins PB7 to PB0.



### 8.7.4 Port B Pull-Up MOS Control Register (PBPCR)

PBPCR controls the on/off state of the port B input pull-up MOS. PBPCR is valid for port input pins.

Bit	Bit Name	Initial Value	R/W	Description
7	PB7PCR	0	R/W	When a pin functions as an input port, setting the corresponding bit to 1 turns on the input pull-up MOS for that pin.
6	PB6PCR	0	R/W	
5	PB5PCR	0	R/W	
4	PB4PCR	0	R/W	
3	PB3PCR	0	R/W	
2	PB2PCR	0	R/W	
1	PB1PCR	0	R/W	
0	PB0PCR	0	R/W	

### 8.7.5 Pin Functions

Port B pins also function as address bus (A15 to A9) output pins. The correspondence between the register specification and the pin functions is shown below.

Note: When using the USB with the emulator (E6000), set A9 and A8 as address bus output pins.

**Table 8.37 PB7 Pin Function**

Operating mode	Modes 4 to 6			Mode 7	
	AE3 to AE0	B'1xxx	Other than B'1xxx		—
PB7DDR	—	0	1	0	1
Pin Function	A15 output pin	PB7 input pin	PB7 output pin	PB7 input pin	PB7 output pin

**Table 8.38 PB6 Pin Function**

Operating mode	Modes 4 to 6			Mode 7	
	AE3 to AE0	B'0111 or B'1xxx	Other than B'0111 or B'1xxx		—
PB6DDR	—	0	1	0	1
Pin Function	A14 output pin	PB6 input pin	PB6 output pin	PB6 input pin	PB6 output pin

**Table 8.39 PB5 Pin Function**

Operating mode	Modes 4 to 6			Mode 7	
	AE3 to AE0	B'011x or B'1xxx	Other than B'011x or B'1xxx		—
PB5DDR	—	0	1	0	1
Pin Function	A13 output pin	PB5 input pin	PB5 output pin	PB5 input pin	PB5 output pin

**Table 8.40 PB4 Pin Function**

Operating mode	Modes 4 to 6			Mode 7	
AE3 to AE0	Other than B'0100 or B'00xx	B'0100 or B'00xx		—	
PB4DDR	—	0	1	0	1
Pin Function	A12 output pin	PB4 input pin	PB4 output pin	PB4 input pin	PB4 output pin

**Table 8.41 PB3 Pin Function**

Operating mode	Modes 4 to 6			Mode 7	
AE3 to AE0	Other than B'00xx	B'00xx		—	
PB3DDR	—	0	1	0	1
Pin Function	A11 output pin	PB3 input pin	PB3 output pin	PB3 input pin	PB3 output pin

**Table 8.42 PB2 Pin Function**

Operating mode	Modes 4 to 6			Mode 7	
AE3 to AE0	Other than B'0010 or B'000x	B'0010 or B'000x		—	
PB2DDR	—	0	1	0	1
Pin Function	A10 output pin	PB2 input pin	PB2 output pin	PB2 input pin	PB2 output pin

**Table 8.43 PB1 Pin Function**

Operating mode	Modes 4 to 6			Mode 7	
AE3 to AE0	Other than B'000x	B'000x		—	
PB1DDR	—	0	1	0	1
Pin Function	A9 output pin	PB1 input pin	PB1 output pin	PB1 input pin	PB1 output pin

**Table 8.44 PB0 Pin Function**

Operating mode	Modes 4 to 6			Mode 7	
AE3 to AE0	Other than B'0000	B'0000		—	
PB0DDR	—	0	1	0	1
Pin Function	A8 output pin	PB0 input pin	PB0 output pin	PB0 input pin	PB0 output pin

Legend:

x: Don't care.

### 8.7.6 Port B Input Pull-Up MOS States

The port B has an on-chip input pull-up MOS function that can be controlled by software. The input pull-up MOS can be specified as the on or off state for individual bits.

Table 8.45 summarizes the input pull-up MOS states.

**Table 8.45 Input Pull-Up MOS States (Port B)**

Pins	Power-On Reset	Hardware Standby Mode	Manual Reset	Software Standby Mode	In Other Operations
Address output, port output	Off		Off		
Port input			On/Off		

Legend:

Off: Input pull-up MOS is always off.

On/Off: On when PBDDR = 0 and PBPCR = 1; otherwise off.

## 8.8 Port C (H8S/2218 Group Only)

The port C is an 8-bit I/O port also functioning as address bus (A7 to A0) output pins. The port C has the following registers.

Note: When the RTC and USB are used while the E6000 emulator is used, the PC7DDR to PC0DDR bits in PCDDR must be set so that the PC7 to PC0 pins output addresses A7 to A0. This note applies to both the H8S/2218 Group and H8S/2212 Group.

- Port C data direction register (PCDDR)
- Port C data register (PCDR)
- Port C register (PORTC)
- Port C pull-up MOS control register (PCPCR)

### 8.8.1 Port C Data Direction Register (PCDDR)

PCDDR specifies input or output for the pins of the port C.

Since PCDDR is a write-only register, the bit manipulation instructions must not be used to write PCDDR. For details, see section 2.9.4, Accessing Registers Containing Write-Only Bits.

Bit	Bit Name	Initial Value	R/W	Description
7	PC7DDR	0	W	Modes 4 and 5:
6	PC6DDR	0	W	Port C pins are address output pins.
5	PC5DDR	0	W	Mode 6:
4	PC4DDR	0	W	Setting a PCDDR bit to 1 makes the corresponding port C pin an address output pin, while clearing the bit to 0
3	PC3DDR	0	W	makes the pin an input port.
2	PC2DDR	0	W	Mode 7:
1	PC1DDR	0	W	Setting a PCDDR bit to 1 makes the corresponding port C pin an output port, while clearing the bit to 0 makes the
0	PC0DDR	0	W	pin an input port.

### 8.8.2 Port C Data Register (PCDR)

PCDR stores output data for the port C pins.

Bit	Bit Name	Initial Value	R/W	Description
7	PC7DR	0	R/W	Store output data for a pin that functions as a general output port.
6	PC6DR	0	R/W	
5	PC5DR	0	R/W	
4	PC4DR	0	R/W	
3	PC3DR	0	R/W	
2	PC2DR	0	R/W	
1	PC1DR	0	R/W	
0	PC0DR	0	R/W	

### 8.8.3 Port C Register (PORTC)

PORTC indicates the pin states of the port C.

Bit	Bit Name	Initial Value	R/W	Description
7	PC7	—*	R	If the port C is read while PCDDR bits are set to 1, the PCDR value is read. If the port C is read while PCDDR bits are cleared to 0, the pin states are read.
6	PC6	—*	R	
5	PC5	—*	R	
4	PC4	—*	R	
3	PC3	—*	R	
2	PC2	—*	R	
1	PC1	—*	R	
0	PC0	—*	R	

Note: \* Determined by the states of pins PC7 to PC0.

### 8.8.4 Port C Pull-Up MOS Control Register (PCPCR)

PCPCR controls the on/off state of the port C input pull-up MOS.

Bit	Bit Name	Initial Value	R/W	Description
7	PC7PCR	0	R/W	When a pin functions as an input port, setting the corresponding bit to 1 turns on the input pull-up MOS for that pin.
6	PC6PCR	0	R/W	
5	PC5PCR	0	R/W	
4	PC4PCR	0	R/W	
3	PC3PCR	0	R/W	
2	PC2PCR	0	R/W	
1	PC1PCR	0	R/W	
0	PC0PCR	0	R/W	

### 8.8.5 Pin Functions

Port C pins also function as address bus (A7 to A0) output pins. The correspondence between the register specification and the pin functions is shown below.

Note: When using the RTC and USB with the emulator (E6000), set A7 to A0 as address bus output pins.

**Table 8.46 PC7 Pin Function**

Operating Mode	Modes 4 and 5	Mode 6		Mode 7	
PC7DDR	—	0	1	0	1
Pin Function	A7 output pin	PC7 input pin	A7 output pin	PC7 input pin	PC7 output pin

**Table 8.47 PC6 Pin Function**

Operating Mode	Modes 4 and 5	Mode 6		Mode 7	
PC6DDR	—	0	1	0	1
Pin Function	A6 output pin	PC6 input pin	A6 output pin	PC6 input pin	PC6 output pin

**Table 8.48 PC5 Pin Function**

Operating Mode	Modes 4 and 5	Mode 6		Mode 7	
PC5DDR	—	0	1	0	1
Pin Function	A5 output pin	PC5 input pin	A5 output pin	PC5 input pin	PC5 output pin

**Table 8.49 PC4 Pin Function**

Operating Mode	Modes 4 and 5	Mode 6		Mode 7	
PC4DDR	—	0	1	0	1
Pin Function	A4 output pin	PC4 input pin	A4 output pin	PC4 input pin	PC4 output pin

**Table 8.50 PC3 Pin Function**

Operating Mode	Modes 4 and 5	Mode 6		Mode 7	
PC3DDR	—	0	1	0	1
Pin Function	A3 output pin	PC3 input pin	A3 output pin	PC3 input pin	PC3 output pin

**Table 8.51 PC2 Pin Function**

Operating Mode	Modes 4 and 5	Mode 6		Mode 7	
PC2DDR	—	0	1	0	1
Pin Function	A2 output pin	PC2 input pin	A2 output pin	PC2 input pin	PC2 output pin

**Table 8.52 PC1 Pin Function**

Operating Mode	Modes 4 and 5	Mode 6		Mode 7	
PC1DDR	—	0	1	0	1
Pin Function	A1 output pin	PC1 input pin	A1 output pin	PC1 input pin	PC1 output pin



**Table 8.53 PC0 Pin Function**

Operating Mode	Modes 4 and 5	Mode 6		Mode 7	
PC0DDR	—	0	1	0	1
Pin Function	A0 output pin	PC0 input pin	A0 output pin	PC0 input pin	PC0 output pin

### 8.8.6 Port C Input Pull-Up MOS States

The port C has an on-chip input pull-up MOS function that can be controlled by software. The input pull-up MOS can be used in modes 6 and 7, and can be specified as the on or off state for individual bits.

Table 8.54 summarizes the input pull-up MOS states.

**Table 8.54 Input Pull-Up MOS States (Port C)**

Pins	Power-On Reset	Hardware Standby Mode	Manual Reset	Software Standby Mode	In Other Operations
Address output (modes 4 and 5), port output (modes 6 and 7)			Off		
Port input (modes 6 and 7)			On/Off		

Legend:

Off: Input pull-up MOS is always off.

On/Off: On when PCDDR = 0 and PCPCR = 1; otherwise off.

## 8.9 Port D (H8S/2218 Group Only)

The port D is an 8-bit I/O port also functioning as data bus (D15 to D8) I/O pins. The port D has the following registers.

- Port D data direction register (PDDDR)
- Port D data register (PDDR)
- Port D register (PORTD)
- Port D pull-up MOS control register (PDPCR)

### 8.9.1 Port D Data Direction Register (PDDDR)

PDDDR specifies input or output for the pins of the port D.

Since PDDDR is a write-only register, the bit manipulation instructions must not be used to write PDDDR. For details, see section 2.9.4, Accessing Registers Containing Write-Only Bits.

Bit	Bit Name	Initial Value	R/W	Description
7	PD7DDR	0	W	Modes 4 to 6:
6	PD6DDR	0	W	Port D pins automatically function as data input/output pins.
5	PD5DDR	0	W	Mode 7:
4	PD4DDR	0	W	Setting a PDDDR bit to 1 makes the corresponding port D
3	PD3DDR	0	W	pin an output port, while clearing the bit to 0 makes the
2	PD2DDR	0	W	pin an input port.
1	PD1DDR	0	W	
0	PD0DDR	0	W	

### 8.9.2 Port D Data Register (PDDR)

PDDR stores output data for the port D pins.

Bit	Bit Name	Initial Value	R/W	Description
7	PD7DR	0	R/W	Store output data for a pin that functions as a general output port.
6	PD6DR	0	R/W	
5	PD5DR	0	R/W	
4	PD4DR	0	R/W	
3	PD3DR	0	R/W	
2	PD2DR	0	R/W	
1	PD1DR	0	R/W	
0	PD0DR	0	R/W	

### 8.9.3 Port D Register (PORTD)

PORTD indicates the pin states of the port D.

Bit	Bit Name	Initial Value	R/W	Description
7	PD7	—*	R	If the port D is read while PDDDR bits are set to 1, the PDDR value is read. If the port D is read while PDDDR bits are cleared to 0, the pin states are read.
6	PD6	—*	R	
5	PD5	—*	R	Note: After accessing EXMDLSTP or the RTC register (address range: H'FFFF40 to H'FFFF5F), you must perform a dummy read to the external address space (such as H'FFEF00 to H'FF7FF) outside the range H'FFFF40 to H'FFFF5F before reading PORTD.
4	PD4	—*	R	
3	PD3	—*	R	
2	PD2	—*	R	
1	PD1	—*	R	
0	PD0	—*	R	

Note: \* Determined by the states of pins PD7 to PD0.

### 8.9.4 Port D Pull-Up MOS Control Register (PDPCR)

PDPCR controls the on/off state of the port D input pull-up MOS.

Bit	Bit Name	Initial Value	R/W	Description
7	PD7PCR	0	R/W	When a pin functions as an input port, setting the corresponding bit to 1 turns on the input pull-up MOS for that pin.
6	PD6PCR	0	R/W	
5	PD5PCR	0	R/W	
4	PD4PCR	0	R/W	
3	PD3PCR	0	R/W	
2	PD2PCR	0	R/W	
1	PD1PCR	0	R/W	
0	PD0PCR	0	R/W	

### 8.9.5 Pin Functions

Port D pins also function as data bus (D15 to D8) I/O pins. The correspondence between the register specification and the pin functions is shown below.

**Table 8.55 PD7 Pin Function**

Operating Mode	Modes 4 to 6	Mode 7	
PD7DDR	—	0	1
Pin Function	D15 input/output pin	PD7 input pin	PD7 output pin

**Table 8.56 PD6 Pin Function**

Operating Mode	Modes 4 to 6	Mode 7	
PD6DDR	—	0	1
Pin Function	D14 input/output pin	PD6 input pin	PD6 output pin

**Table 8.57 PD5 Pin Function**

Operating Mode	Modes 4 to 6	Mode 7	
PD5DDR	—	0	1
Pin Function	D13 input/output pin	PD5 input pin	PD5 output pin

**Table 8.58 PD4 Pin Function**

Operating Mode	Modes 4 to 6	Mode 7	
PD4DDR	—	0	1
Pin Function	D12 input/output pin	PD4 input pin	PD4 output pin

**Table 8.59 PD3 Pin Function**

Operating Mode	Modes 4 to 6	Mode 7	
PD3DDR	—	0	1
Pin Function	D11 input/output pin	PD3 input pin	PD3 output pin

**Table 8.60 PD2 Pin Function**

Operating Mode	Modes 4 to 6	Mode 7	
PD2DDR	—	0	1
Pin Function	D10 input/output pin	PD2 input pin	PD2 output pin

**Table 8.61 PD1 Pin Function**

Operating Mode	Modes 4 to 6	Mode 7	
PD1DDR	—	0	1
Pin Function	D9 input/output pin	PD1 input pin	PD1 output pin

**Table 8.62 PD0 Pin Function**

Operating Mode	Modes 4 to 6	Mode 7	
PD0DDR	—	0	1
Pin Function	D8 input/output pin	PD0 input pin	PD0 output pin

### 8.9.6 Port D Input Pull-Up MOS States

The port D has an on-chip input pull-up MOS function that can be controlled by software. The input pull-up MOS can be used in mode 7, and can be specified as the on or off state for individual bits.

Table 8.63 summarizes the input pull-up MOS states.

**Table 8.63 Input Pull-Up MOS States (Port D)**

<b>Pins</b>	<b>Power-On Reset</b>	<b>Hardware Standby Mode</b>	<b>Manual Reset</b>	<b>Software Standby Mode</b>	<b>In Other Operations</b>
Data input/output (modes 4 to 6), port output (mode 7)	Off		Off		
Port input (mode 7)			On/Off		

Legend:

Off: Input pull-up MOS is always off.

On/Off: On when PDDDR = 0 and PDPCR = 1; otherwise off.

## 8.10 Port E

The port E is an 8-bit I/O port also functioning as data bus (D7 to D0) I/O pins. The port E has the following registers.

- Port E data direction register (PEDDR)
- Port E data register (PEDR)
- Port E register (PORTE)
- Port E pull-up MOS control register (PEPCR)

### 8.10.1 Port E Data Direction Register (PEDDR)

PEDDR specifies input or output for the pins of the port E.

Since PEDDR is a write-only register, the bit manipulation instructions must not be used to write PEDDR. For details, see section 2.9.4, Accessing Registers Containing Write-Only Bits.

Bit	Bit Name	Initial Value	R/W	Description
7	PE7DDR	0	W	(H8S/2218 Group)
6	PE6DDR	0	W	Modes 4 to 6:
5	PE5DDR	0	W	When 8-bit bus mode is selected, port E functions as an I/O port. Setting a PEDDR bit to 1 makes the corresponding port E pin an output port, while clearing the bit to 0 makes the pin an input port.
4	PE4DDR	0	W	
3	PE3DDR	0	W	
2	PE2DDR	0	W	When 16-bit bus mode is selected, the input/output direction settings in PEDDR are ignored, and port E pins automatically function as data input/output pins.
1	PE1DDR	0	W	
0	PE0DDR	0	W	For details on 8-bit/16-bit bus mode, refer to section 6, Bus Controller.  Mode 7: Setting a PEDDR bit to 1 makes the corresponding port E pin an output port, while clearing the bit to 0 makes the pin an input port. (H8S/2212 Group)  Setting a PEDDR bit to 1 makes the corresponding port E pin an output port, while clearing the bit to 0 makes the pin an input port.

### 8.10.2 Port E Data Register (PEDR)

PEDR stores output data for the port E pins.

Bit	Bit Name	Initial Value	R/W	Description
7	PE7DR	0	R/W	Store output data for a pin that functions as a general output port.
6	PE6DR	0	R/W	
5	PE5DR	0	R/W	
4	PE4DR	0	R/W	
3	PE3DR	0	R/W	
2	PE2DR	0	R/W	
1	PE1DR	0	R/W	
0	PE0DR	0	R/W	

### 8.10.3 Port E Register (PORTE)

PORTE indicates the pin states of the port E.

Bit	Bit Name	Initial Value	R/W	Description
7	PE7	—*	R	If the port E is read while PEDDR bits are set to 1, the PEDR value is read. If the port E is read while PEDDR bits are cleared to 0, the pin states are read.
6	PE6	—*	R	
5	PE5	—*	R	
4	PE4	—*	R	
3	PE3	—*	R	
2	PE2	—*	R	
1	PE1	—*	R	
0	PE0	—*	R	

Note: \* Determined by the states of pins PE7 to PE0.



### 8.10.4 Port E Pull-Up MOS Control Register (PEPCR)

PEPCR controls the on/off state of the port E input pull-up MOS.

Bit	Bit Name	Initial Value	R/W	Description
7	PE7PCR	0	R/W	When a pin functions as an input port, setting the corresponding bit to 1 turns on the input pull-up MOS for that pin.
6	PE6PCR	0	R/W	
5	PE5PCR	0	R/W	
4	PE4PCR	0	R/W	
3	PE3PCR	0	R/W	
2	PE2PCR	0	R/W	
1	PE1PCR	0	R/W	
0	PE0PCR	0	R/W	

### 8.10.5 Pin Functions

#### Pin Functions of H8S/2218 Group

Port E pins also function as data bus (D7 to D0) I/O pins. The correspondence between the register specification and the pin function is shown below.

**Table 8.64 PE7 Pin Function**

Operating Mode	Modes 4 to 6			Mode 7	
Bus Mode	8-bit bus mode		16-bit bus mode	—	
PE7DDR	0	1	—	0	1
Pin Function	PE7 input pin	PE7 output pin	D7 input/output pin	PE7 input pin	PE7 output pin

**Table 8.65 PE6 Pin Function**

Operating Mode	Modes 4 to 6			Mode 7	
Bus Mode	8-bit bus mode		16-bit bus mode	—	
PE6DDR	0	1	—	0	1
Pin Function	PE6 input pin	PE6 output pin	D6 input/output pin	PE6 input pin	PE6 output pin

**Table 8.66 PE5 Pin Function**

Operating Mode	Modes 4 to 6			Mode 7	
Bus Mode	8-bit bus mode		16-bit bus mode	—	
PE5DDR	0	1	—	0	1
Pin Function	PE5 input pin	PE5 output pin	D5 input/output pin	PE5 input pin	PE5 output pin

**Table 8.67 PE4 Pin Function**

Operating Mode	Modes 4 to 6			Mode 7	
Bus Mode	8-bit bus mode		16-bit bus mode	—	
PE4DDR	0	1	—	0	1
Pin Function	PE4 input pin	PE4 output pin	D4 input/output pin	PE4 input pin	PE4 output pin

**Table 8.68 PE3 Pin Function**

Operating Mode	Modes 4 to 6			Mode 7	
Bus Mode	8-bit bus mode		16-bit bus mode	—	
PE3DDR	0	1	—	0	1
Pin Function	PE3 input pin	PE3 output pin	D3 input/output pin	PE3 input pin	PE3 output pin

**Table 8.69 PE2 Pin Function**

Operating Mode	Modes 4 to 6			Mode 7	
Bus Mode	8-bit bus mode		16-bit bus mode	—	
PE2DDR	0	1	—	0	1
Pin Function	PE2 input pin	PE2 output pin	D2 input/output pin	PE2 input pin	PE2 output pin

**Table 8.70 PE1 Pin Function**

Operating Mode	Modes 4 to 6			Mode 7	
Bus Mode	8-bit bus mode		16-bit bus mode	—	
PE1DDR	0	1	—	0	1
Pin Function	PE1 input pin	PE1 output pin	D1 input/output pin	PE1 input pin	PE1 output pin

**Table 8.71 PE0 Pin Function**

Operating Mode	Modes 4 to 6			Mode 7	
Bus Mode	8-bit bus mode		16-bit bus mode	—	
PE0DDR	0	1	—	0	1
Pin Function	PE0 input pin	PE0 output pin	D0 input/output pin	PE0 input pin	PE0 output pin

### Pin Functions of H8S/2212 Group

The port E function as a general I/O port. The correspondence between the register specification and the pin function is shown below.

**Table 8.72 PE7 Pin Function**

PE7DDR	0	1
Pin Function	PE7 input pin	PE7 output pin

**Table 8.73 PE6 Pin Function**

PE6DDR	0	1
Pin Function	PE6 input pin	PE6 output pin

**Table 8.74 PE5 Pin Function**

PE5DDR	0	1
Pin Function	PE5 input pin	PE5 output pin

**Table 8.75 PE4 Pin Function**

PE4DDR	0	1
Pin Function	PE4 input pin	PE4 output pin

**Table 8.76 PE3 Pin Function**

PE3DDR	0	1
Pin Function	PE3 input pin	PE3 output pin

**Table 8.77 PE2 Pin Function**

PE2DDR	0	1
Pin Function	PE2 input pin	PE2 output pin

**Table 8.78 PE1 Pin Function**

PE1DDR	0	1
Pin Function	PE1 input pin	PE1 output pin

**Table 8.79 PE0 Pin Function**

PE0DDR	0	1
Pin Function	PE0 input pin	PE0 output pin

### 8.10.6 Port E Input Pull-Up MOS States

The port E has an on-chip input pull-up MOS function that can be controlled by software. The input pull-up MOS can be used in modes 4 to 6 and in 8-bit bus mode, or in mode 7, and can be specified as the on or off state for individual bits.

Table 8.80 summarizes the input pull-up MOS states.

**Table 8.80 Input Pull-Up MOS States (Port E)**

<b>Pins</b>	<b>Power-On Reset</b>	<b>Hardware Standby Mode</b>	<b>Manual Reset</b>	<b>Software Standby Mode</b>	<b>In Other Operations</b>
Data input/output (16-bit bus mode in modes 4 to 6), port output (8-bit bus mode in modes 4 to 6, mode 7)	Off		Off		
Port input (8-bit bus mode in modes 4 to 6, mode 7)			On/Off		

Legend:

Off: Input pull-up MOS is always off.

On/Off: On when PEDDR = 0 and PEPCR = 1; otherwise off.

## 8.11 Port F

In the H8S/2218 Group, the port F is an 8-bit I/O port also functioning as external interrupt input ( $\overline{\text{IRQ2}}$ ,  $\overline{\text{IRQ3}}$ ) pins, bus control signal I/O pins, and system clock output pins. In the H8S/2212 Group, the port F is a 3-bit I/O port also functioning as external interrupt input ( $\overline{\text{IRQ2}}$ ,  $\overline{\text{IRQ3}}$ ) pins and system clock output pins. The port F has the following registers.

- Port F data direction register (PFDDR)
- Port F data register (PFDR)
- Port F register (PORTF)

### 8.11.1 Port F Data Direction Register (PFDDR)

PFDDR specifies input or output for the pins of the port F.

Since PFDDR is a write-only register, the bit manipulation instructions must not be used to write PFDDR. For details, see section 2.9.4, Accessing Registers Containing Write-Only Bits.

Bit	Bit Name	Initial Value	R/W	Description
7	PF7DDR	1/0* <sup>1</sup>	W	(H8S/2218 Group)
6	PF6DDR* <sup>2</sup>	0	W	Modes 4 to 6:
5	PF5DDR* <sup>2</sup>	0	W	Pin PF7 functions as the $\phi$ output pin when the PF7DDR bit is set to 1, and as an input port when the bit is cleared to 0. Pins PF6 to PF3 are automatically designated as bus control output pins. Pins PF2 to PF0 are made bus control
4	PF4DDR* <sup>2</sup>	0	W	input/output pins by bus controller settings. Otherwise, setting a PFDDR bit to 1 makes the corresponding pin an output port, while clearing the bit to 0 makes the pin an input port.
3	PF3DDR	0	W	
2	PF2DDR* <sup>2</sup>	0	W	
1	PF1DDR* <sup>2</sup>	0	W	
0	PF0DDR	0	W	Mode 7 Setting a PFDDR bit to 1 makes the corresponding port F pin PF6 to PF0 an output port, or in the case of pin PF7, the $\phi$ output pin. Clearing the bit to 0 makes the pin an input port. (H8S/2212 Group) Setting a PFDDR bit to 1 makes the corresponding port F pin PF6 to PF0 an output port, or in the case of pin PF7, the $\phi$ output pin. Clearing the bit to 0 makes the pin an input port.

- 
- Notes: 1. The initial value becomes 1 in modes 4 to 6 and 0 in mode 7.  
2. Reserved in the H8S/2212 Group. If this bit is read, an undefined value will be read. This bit cannot be modified.

### 8.11.2 Port F Data Register (PFDR)

PFDR stores output data for the port F pins.

Bit	Bit Name	Initial Value	R/W	Description
7	PF7DR	0	R/W	Store output data for a pin that functions as a general output port.
6	PF6DR*	0	R/W	
5	PF5DR*	0	R/W	
4	PF4DR*	0	R/W	
3	PF3DR	0	R/W	
2	PF2DR*	0	R/W	
1	PF1DR*	0	R/W	
0	PF0DR	0	R/W	

Note: \* Reserved in the H8S/2212 Group. If this bit is read, an undefined value will be read. This bit cannot be modified.

### 8.11.3 Port F Register (PORTF)

PORTF indicates the pin states of the port F.

Bit	Bit Name	Initial Value	R/W	Description
7	PF7	—* <sup>1</sup>	R	If the port F is read while PFDDR bits are set to 1, the PFDR value is read. If the port F is read while PFDDR bits are cleared to 0, the pin states are read.
6	PF6* <sup>2</sup>	—* <sup>1</sup>	R	
5	PF5* <sup>2</sup>	—* <sup>1</sup>	R	
4	PF4* <sup>2</sup>	—* <sup>1</sup>	R	
3	PF3	—* <sup>1</sup>	R	
2	PF2* <sup>2</sup>	—* <sup>1</sup>	R	
1	PF1* <sup>2</sup>	—* <sup>1</sup>	R	
0	PF0	—* <sup>1</sup>	R	

Notes: 1. Determined by the states of pins PF7 to PF0.

2. Reserved in the H8S/2212 Group. If this bit is read, an undefined value will be read.

### 8.11.4 Clock Output Control Register (OUTCR)

OUTCR specifies the clock frequency output from the PF7 pin.

Bit	Bit Name	Initial Value	R/W	Description
7 to 3	—	Undefined	—	Reserved The write value should always be 0.
2	PF7OUT2	0	R/W	PF7 Pin Output Select 2 to 0
1	PF7OUT1	0	R/W	000: Main oscillation clock
0	PF7OUT0	0	R/W	001: Outputs 1/2 of main oscillation clock 010: Outputs 1/3 of main oscillation clock 011: Outputs 1/4 of main oscillation clock 1xx: Reserved This function is not supported by the E6000 emulator. $\phi$ in section 22, Electrical Characteristics is in the case when PF7OUT2 to PF7OUT0 = 000.

### 8.11.5 Pin Functions

#### Pin Functions of H8S/2218 Group

The port F is an 8-bit I/O port. Port F pins also function as external interrupt input ( $\overline{\text{IRQ2}}$ ,  $\overline{\text{IRQ3}}$ ) pins, bus control signal I/O pins, and system clock output ( $\phi$ ) pins. The correspondence between the register specification and the pin functions is shown below.

**Table 8.81 PF7 Pin Function**

PF7DDR	0	1			
PF7OUT2 to PF7OUT0	—	B'000	B'001	B'010	B'011
Pin Function	PF7 input pin	$\phi$ output pin	$\phi/2$ output pin	$\phi/3$ output pin	$\phi/4$ output pin

**Table 8.82 PF6 Pin Function**

Operating Mode	Modes 4 to 6	Mode 7	
PF6DDR	—	0	1
Pin Function	$\overline{\text{AS}}$ output pin	PF6 input pin	PF6 output pin



**Table 8.83 PF5 Pin Function**

Operating Mode	Modes 4 to 6	Mode 7	
PF5DDR	—	0	1
Pin Function	$\overline{RD}$ output pin	PF5 input pin	PF5 output pin

**Table 8.84 PF4 Pin Function**

Operating Mode	Modes 4 to 6	Mode 7	
PF4DDR	—	0	1
Pin Function	$\overline{HWR}$ output pin	PF4 input pin	PF4 output pin

**Table 8.85 PF3 Pin Function**

Operating Mode	Modes 4 to 6			Mode 7	
Bus Mode	16-bit bus mode	8-bit bus mode		—	
PF3DDR	—	0	1	0	1
Pin Function	$\overline{LWR}$ output pin	PF3 input pin	PF3 output pin	PF3 input pin	PF3 output pin
		$\overline{ADTRG}$ input pin* <sup>1</sup>			
		$\overline{IRQ3}$ input pin* <sup>2</sup>			

Notes: 1.  $\overline{ADTRG}$  input pin when TRGS0 = TRGS1 = 1.

2. When this pin is used as an external interrupt input pin, this pin must not be used as an I/O pin for another function.

**Table 8.86 PF2 Pin Function**

Operating Mode	Modes 4 to 6			Mode 7	
WAITE	0		1	—	
PF2DDR	0	1	—	0	1
Pin Function	PF2 input pin	PF2 output pin	$\overline{WAIT}$ input pin	PF2 input pin	PF2 output pin

**Table 8.87 PF1 Pin Function**

Operating Mode	Modes 4 to 6			Mode 7	
BRLE	0		1	—	
PF1DDR	0	1	—	0	1
Pin Function	PF1 input pin	PF1 output pin	$\overline{\text{BACK}}$ output pin	PF1 input pin	PF1 output pin

**Table 8.88 PF0 Pin Function**

Operating Mode	Modes 4 to 6			Mode 7	
BRLE	0		1	—	
PF0DDR	0	1	—	0	1
Pin Function	PF0 input pin	PF0 output pin	$\overline{\text{BREQ}}$ input pin	PF0 input pin	PF0 output pin
	$\overline{\text{IRQ2}}$ input pin*				

Note: \* When this pin is used as an external interrupt input pin, this pin must not be used as an I/O pin for another function.

### Pin Functions of H8S/2212 Group

The port F is a 3-bit I/O port. Port F pins also function as external interrupt input ( $\overline{\text{IRQ2}}$ ,  $\overline{\text{IRQ3}}$ ) pins and system clock output ( $\phi$ ) pins. The correspondence between the register specification and the pin functions is shown below.

**Table 8.89 PF7 Pin Function**

PF7DDR	0	1			
PF7OUT2 to PF7OUT0	—	B'000	B'001	B'010	B'011
Pin Function	PF7 input pin	$\phi$ output pin	$\phi/2$ output pin	$\phi/3$ output pin	$\phi/4$ output pin

**Table 8.90 PF3 Pin Function**

PF3DDR	0	1
Pin Function	PF3 input pin	PF3 output pin
	$\overline{\text{ADTRG}}$ input pin* <sup>1</sup>	
	$\overline{\text{IRQ3}}$ input pin* <sup>2</sup>	

Notes: 1.  $\overline{\text{ADTRG}}$  input pin when TRGS0 = TRGS1 = 1.  
 2. When this pin is used as an external interrupt input pin, this pin must not be used as an I/O pin for another function.

**Table 8.91 PF0 Pin Function**

PF0DDR	0	1
Pin Function	PF0 input pin	PF0 output pin
	$\overline{\text{IRQ2}}$ input pin*	

Note: \* When this pin is used as an external interrupt input pin, this pin must not be used as an I/O pin for another function.

## 8.12 Port G

In the H8S/2218 Group, the port G is a 4-bit I/O port also functioning as external interrupt input ( $\overline{\text{IRQ7}}$ ) pins and bus control output ( $\overline{\text{CS0}}$  to  $\overline{\text{CS3}}$ ) pins. In the H8S/2212 Group, the port G is a 2-bit I/O port also functioning as external interrupt input ( $\overline{\text{IRQ7}}$ ) pins and H-UDI (TDI) pins. The port G has the following registers.

- Port G data direction register (PGDDR)
- Port G data register (PGDR)
- Port G register (PORTG)

### 8.12.1 Port G Data Direction Register (PGDDR)

PGDDR specifies input or output for the pins of the port G.

Since PGDDR is a write-only register, the bit manipulation instructions must not be used to write PGDDR. For details, see section 2.9.4, Accessing Registers Containing Write-Only Bits.

Bit	Bit Name	Initial Value	R/W	Description
7 to 5	—	Undefined	—	Reserved These bits are undefined and cannot be modified.
4	PG4DDR* <sup>2</sup> 0/1* <sup>1</sup>	0	W	(H8S/2218 Group)
3	PG3DDR* <sup>2</sup> 0	0	W	Modes 4 to 6:
2	PG2DDR* <sup>2</sup> 0	0	W	Setting a PGDDR bit to 1 makes the PG4 to PG1 pins bus control signal output pins, while clearing the bit to 0 makes the pins input ports.
1	PG1DDR 0	0	W	Mode 7: Setting a PGDDR bit to 1 makes the corresponding port G pin an output port, while clearing the bit to 0 makes the pin an input port. (H8S/2212 Group) Setting a PG1DDR bit to 1 makes the corresponding port G pin an output port, while clearing the bit to 0 makes the pin an input port.
0	PG0DDR* <sup>3</sup> 0	0	W	(H8S/2212 Group) When EMLE = 1: Pin PG0 function as the H-UDI (TDI) pin. When EMLE = 0: If a PG0DDR bit is set to 1, pin PG0 function as output ports. If a PG0DDR bit is cleared to 0, pin PG0 function as input ports.

- Notes:
1. The initial value becomes 1 in modes 4 and 5 and 0 in modes 6 and 7.
  2. Reserved in the H8S/2212 Group. If this bit is read, an undefined value will be read. This bit cannot be modified.
  3. Reserved in the H8S/2218 Group. If this bit is read, an undefined value will be read. This bit cannot be modified.

### 8.12.2 Port G Data Register (PGDR)

PGDR stores output data for the port G pins.

Bit	Bit Name	Initial Value	R/W	Description
7 to 5	—	Undefined	—	Reserved These bits are undefined and cannot be modified.
4	PG4DR* <sup>1</sup>	0	R/W	Store output data for a pin that functions as a general output port.
3	PG3DR* <sup>1</sup>	0	R/W	
2	PG2DR* <sup>1</sup>	0	R/W	
1	PG1DR	0	R/W	
0	PG0DR* <sup>2</sup>	0	R/W	

Notes: 1. Reserved in the H8S/2212 Group. If this bit is read, an undefined value will be read. This bit cannot be modified.  
2. Reserved in the H8S/2218 Group. If this bit is read, an undefined value will be read. This bit cannot be modified.

### 8.12.3 Port G Register (PORTG)

PORTG indicates the pin states of the port G.

Bit	Bit Name	Initial Value	R/W	Description
7 to 5	—	Undefined	—	Reserved These bits are undefined.
4	PG4* <sup>2</sup>	—* <sup>1</sup>	R	If the port G is read while PGDDR bits are set to 1, the PGDR value is read. If the port G is read while PGDDR bits are cleared to 0, the pin states are read.
3	PG3* <sup>2</sup>	—* <sup>1</sup>	R	
2	PG2* <sup>2</sup>	—* <sup>1</sup>	R	
1	PG1	—* <sup>1</sup>	R	
0	PG0* <sup>3</sup>	—* <sup>1</sup>	R	

Notes: 1. Determined by the states of pins PG4 to PG0.  
2. Reserved in the H8S/2212 Group. If this bit is read, an undefined value will be read.  
3. Reserved in the H8S/2218 Group. If this bit is read, an undefined value will be read.

## 8.12.4 Pin Functions

### Pin Functions of H8S/2218 Group

Port G pins also function as external interrupt input ( $\overline{\text{IRQ7}}$ ) pins and bus control signal output ( $\overline{\text{CS0}}$  to  $\overline{\text{CS3}}$ ) pins. The correspondence between the register specification and the pin functions is shown below.

**Table 8.92 PG4 Pin Function**

Operating Mode	Modes 4 to 6		Mode 7	
PG4DDR	0	1	0	1
Pin Function	PG4 input pin	$\overline{\text{CS0}}$ output pin	PG4 input pin	PG4 output pin

**Table 8.93 PG3 Pin Function**

Operating Mode	Modes 4 to 6		Mode 7	
PG3DDR	0	1	0	1
Pin Function	PG3 input pin	$\overline{\text{CS1}}$ output pin	PG3 input pin	PG3 output pin

**Table 8.94 PG2 Pin Function**

Operating Mode	Modes 4 to 6		Mode 7	
PG2DDR	0	1	0	1
Pin Function	PG2 input pin	$\overline{\text{CS2}}$ output pin	PG2 input pin	PG2 output pin

**Table 8.95 PG1 Pin Function**

Operating Mode	Modes 4 to 6		Mode 7	
PG1DDR	0	1	0	1
Pin Function	PG1 input pin	$\overline{\text{CS3}}$ output pin	PG1 input pin	PG1 output pin
	$\overline{\text{IRQ7}}$ input pin*			

Note: \*When this pin is used as an external interrupt input pin, this pin must not be used as an I/O pin for another function.

## Pin Functions of H8S/2212 Group

Port G pins also function as external interrupt input ( $\overline{\text{IRQ7}}$ ) pins and H-UDI (TDI) pins. The correspondence between the register specification and the pin functions is shown below.

**Table 8.96 PG1 Pin Function**

PG1DDR	0	1
Pin Function	PG1 input pin	PG1 output pin
	$\overline{\text{IRQ7}}$ input pin*	

Note: \*When this pin is used as an external interrupt input pin, this pin must not be used as an I/O pin for another function.

**Table 8.97 PG0 Pin Function**

EMLE	0		1
PG0DDR	0	1	—
Pin Function	PG0 input pin	PG0 output pin	TDI input pin

## 8.13 Handling of Unused Pins

Unused input pins should be fixed high or low. Generally, the input pins of CMOS products are high-impedance. Leaving unused pins open can cause the generation of intermediate levels due to peripheral noise induction. This can result in shoot-through current inside the device and cause it to malfunction. Table 8.98 lists examples of ways to handle unused pins. For the handling of dedicated boundary scan pins that are unused, see section 13.2, Pin Configuration, and section 13.5, Usage Notes. Pins marked NC should be left open. For the handling of dedicated USB pins that are unused, see section 14.8.14, Pin Processing when USB Not Used.

**Table 8.98 Examples of Ways to Handle Unused Input Pins**

<b>Port Name</b>	<b>Pin Handling Example</b>
Port 1	Connect each pin to Vcc (pull-up) or to Vss (pull-down) via a resistor.
Port 3	
Port 4	Connect each pin to AVcc (pull-up) or to AVss (pull-down) via a resistor.
Port 7	Connect each pin to Vcc (pull-up) or to Vss (pull-down) via a resistor.
Port 9	Connect each pin to AVcc (pull-up) or to AVss (pull-down) via a resistor.
Port A	Connect each pin to Vcc (pull-up) or to Vss (pull-down) via a resistor.
Port B*	* Ports B, C, and D apply to the H8S/2218 Group only.
Port C*	
Port D*	
Port E	
Port F	
Port G	



## Section 9 16-Bit Timer Pulse Unit (TPU)

This LSI has an on-chip 16-bit timer pulse unit (TPU) that comprises three 16-bit timer channels. The function list of the 16-bit timer unit and its block diagram are shown in table 9.1 and figure 9.1, respectively.

### 9.1 Features

- Maximum 8-pulse input/output
- Selection of 8 counter input clocks for each channel
- The following operations can be set for each channel  
Waveform output at compare match, input capture function, counter clear operation, simultaneous writing to multiple timer counters (TCNT), simultaneous clearing using compare match or input capture, simultaneous input/output for individual registers using counter synchronous operation, PWM output using user-defined duty, up to 7-phase PWM output by combination with synchronous operation
- Buffer operation settable for channel 0
- Phase counting mode settable independently for each of channels 1 and 2
- Fast access via internal 16-bit bus
- 13 interrupt sources
- Automatic transfer of register data
- A/D converter conversion start trigger can be generated
- Module stop mode can be set
- Baud rate clock for the SCI0 can be generated

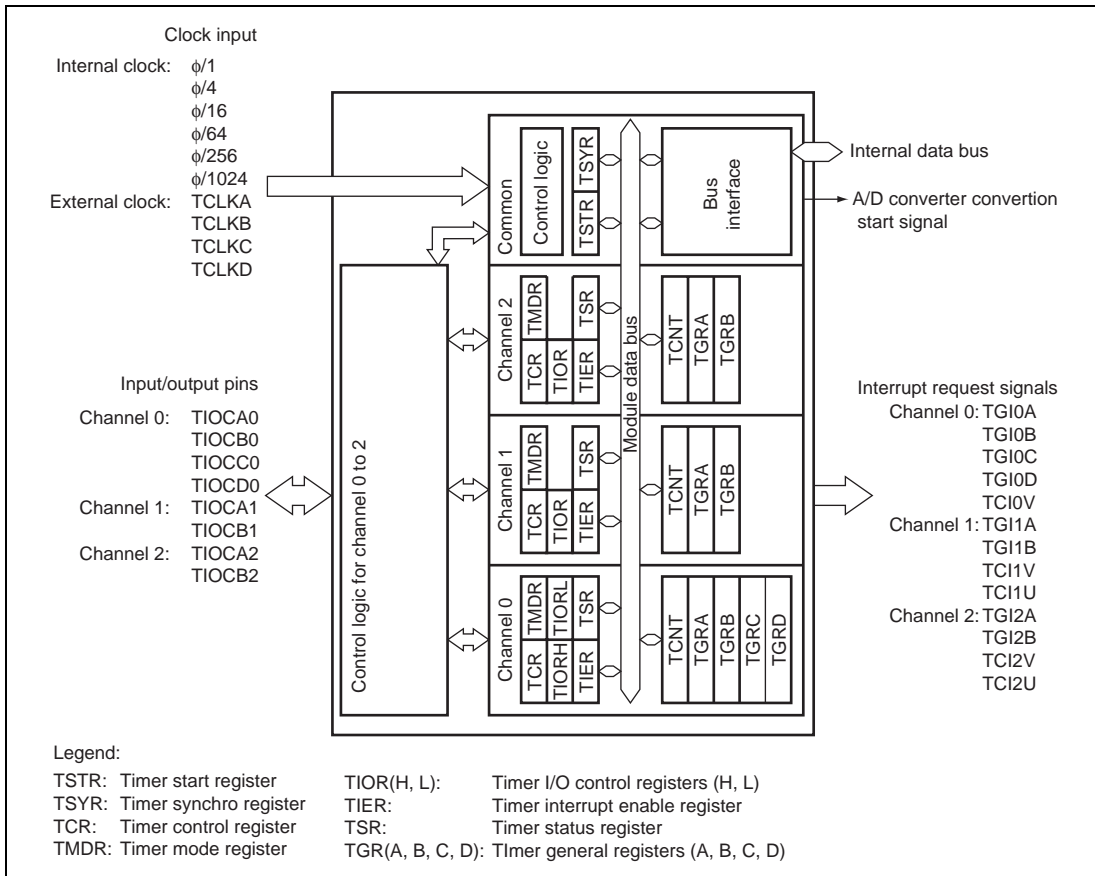


Figure 9.1 Block Diagram of TPU

**Table 9.1 TPU Functions**

<b>Item</b>	<b>Channel 0</b>	<b>Channel 1</b>	<b>Channel 2</b>
Count clock	$\phi/1$	$\phi/1$	$\phi/1$
	$\phi/4$	$\phi/4$	$\phi/4$
	$\phi/16$	$\phi/16$	$\phi/16$
	$\phi/64$	$\phi/64$	$\phi/64$
	TCLKA	$\phi/256$	$\phi/1024$
	TCLKB	TCLKA	TCLKA
	TCLKC	TCLKB	TCLKB
	TCLKD		TCLKC
General registers	TGRA_0	TGRA_1	TGRA_2
	TGRB_0	TGRB_1	TGRB_2
General registers/buffer registers	TGRC_0	–	–
	TGRD_0		
I/O pins	TIOCA0	TIOCA1	TIOCA2
	TIOCB0	TIOCB1	TIOCB2
	TIOCC0		
	TIOCD0		
Counter clear function	TGR compare match or input capture	TGR compare match or input capture	TGR compare match or input capture
Compare match output	0 output	O	O
	1 output	O	O
	Toggle output	O	O
Input capture function	O	O	O
Synchronous operation	O	O	O
PWM mode	O	O	O
Phase counting mode	–	O	O
Buffer operation	O	–	–

Item	Channel 0	Channel 1	Channel 2
DMAC activation	TGRA_0 compare match or input capture	TGRA_1 compare match or input capture	TGRA_2 compare match or input capture
A/D converter trigger	TGRA_0 compare match or input capture	TGRA_1 compare match or input capture	TGRA_2 compare match or input capture
Interrupt sources	5 sources <ul style="list-style-type: none"> <li>• Compare match or input capture 0A</li> <li>• Compare match or input capture 0B</li> <li>• Compare match or input capture 0C</li> <li>• Compare match or input capture 0D</li> <li>• Overflow</li> </ul>	4 sources <ul style="list-style-type: none"> <li>• Compare match or input capture 1A</li> <li>• Compare match or input capture 1B</li> <li>• Overflow</li> <li>• Underflow</li> </ul>	4 sources <ul style="list-style-type: none"> <li>• Compare match or input capture 2A</li> <li>• Compare match or input capture 2B</li> <li>• Overflow</li> <li>• Underflow</li> </ul>

Legend:

O: Possible

–: Not possible

## 9.2 Input/Output Pins

**Table 9.2 Pin Configuration**

Channel	Symbol	I/O	Function
All	TCLKA	Input	External clock A input pin (Channel 1 phase counting mode A phase input)
	TCLKB	Input	External clock B input pin (Channel 1 phase counting mode B phase input)
	TCLKC	Input	External clock C input pin (Channel 2 phase counting mode A phase input)
	TCLKD	Input	External clock D input pin (Channel 2 phase counting mode B phase input)
0	TIOCA0	I/O	TGRA_0 input capture input/output compare output/PWM output pin
	TIOCB0	I/O	TGRB_0 input capture input/output compare output/PWM output pin
	TIOCC0	I/O	TGRC_0 input capture input/output compare output/PWM output pin
	TIOCD0	I/O	TGRD_0 input capture input/output compare output/PWM output pin
1	TIOCA1	I/O	TGRA_1 input capture input/output compare output/PWM output pin
	TIOCB1	I/O	TGRB_1 input capture input/output compare output/PWM output pin
2	TIOCA2	I/O	TGRA_2 input capture input/output compare output/PWM output pin
	TIOCB2	I/O	TGRA_2 input capture input/output compare output/PWM output pin

## 9.3 Register Descriptions

The TPU has the following registers.

- Timer control register\_0 (TCR\_0)
- Timer mode register\_0 (TMDR\_0)
- Timer I/O control register H\_0 (TIORH\_0)
- Timer I/O control register L\_0 (TIORL\_0)
- Timer interrupt enable register\_0 (TIER\_0)
- Timer status register\_0 (TSR\_0)
- Timer counter\_0 (TCNT\_0)
- Timer general register A\_0 (TGRA\_0)
- Timer general register B\_0 (TGRB\_0)
- Timer general register C\_0 (TGRC\_0)
- Timer general register D\_0 (TGRD\_0)
- Timer control register\_1 (TCR\_1)
- Timer mode register\_1 (TMDR\_1)
- Timer I/O control register\_1 (TIOR\_1)
- Timer interrupt enable register\_1 (TIER\_1)
- Timer status register\_1 (TSR\_1)
- Timer counter\_1 (TCNT\_1)
- Timer general register A\_1 (TGRA\_1)
- Timer general register B\_1 (TGRB\_1)
- Timer control register\_2 (TCR\_2)
- Timer mode register\_2 (TMDR\_2)
- Timer I/O control register\_2 (TIOR\_2)
- Timer interrupt enable register\_2 (TIER\_2)
- Timer status register\_2 (TSR\_2)
- Timer counter\_2 (TCNT\_2)
- Timer general register A\_2 (TGRA\_2)
- Timer general register B\_2 (TGRB\_2)

### Common Registers

- Timer start register (TSTR)
- Timer synchro register (TSYR)

### 9.3.1 Timer Control Register (TCR)

The TCR registers control the TCNT operation for each channel. The TPU has a total of three TCR registers, one for each channel (channel 0 to 2). TCR register settings should be made only when TCNT operation is stopped.

Bit	Bit Name	Initial value	R/W	Description
7	CCLR2	0	R/W	Counter Clear 2 to 0
6	CCLR1	0	R/W	These bits select the TCNT counter clearing source. See tables 9.3 and 9.4 for details.
5	CCLR0	0	R/W	
4	CKEG1	0	R/W	Clock Edge 1 and 0
3	CKEG0	0	R/W	<p>These bits select the input clock edge. When the internal clock is counted using both edges, the input clock frequency is halved (e.g., <math>\phi/4</math> both edges = <math>\phi/2</math> rising edge). If phase counting mode is used on channels 1, 2, 4, and 5, this setting is ignored and the phase counting mode setting has priority. Internal clock edge selection is valid when the input clock is <math>\phi/4</math> or slower. If <math>\phi/1</math> is selected as the input clock, this setting is ignored and count at falling edge of <math>\phi</math> is selected.</p> <p>00: Count at rising edge            01: Count at falling edge            1x: Count at both edges</p> <p>Legend:            x: Don't care</p>
2	TPSC2	0	R/W	Time Prescaler 2 to 0
1	TPSC1	0	R/W	These bits select the TCNT counter clock. The clock source can be selected independently for each channel. See tables 9.5 to 9.7 for details.
0	TPSC0	0	R/W	

**Table 9.3 CCLR2 to CCLR0 (channel 0)**

Channel	Bit 7	Bit 6	Bit 5	Description
	CCLR2	CCLR1	CCLR0	
0	0	0	0	TCNT clearing disabled
			1	TCNT cleared by TGRA compare match/input capture
			1	TCNT cleared by counter clearing for another channel performing synchronous clearing/synchronous operation* <sup>1</sup>
	1	0	0	TCNT clearing disabled
			1	TCNT cleared by TGRC compare match/input capture* <sup>2</sup>
			1	TCNT cleared by counter clearing for another channel performing synchronous clearing/synchronous operation* <sup>1</sup>

Notes: 1. Synchronous operation setting is performed by setting the SYNC bit in TSYR to 1.

2. When TGRC or TGRD is used as a buffer register. TCNT is not cleared because the buffer register setting has priority, and compare match/input capture dose not occur.

**Table 9.4 CCLR2 to CCLR0 (channels 1 and 2)**

Channel	Bit 7	Bit 6	Bit 5	Description
	Reserved* <sup>2</sup>	CCLR1	CCLR0	
1, 2	0	0	0	TCNT clearing disabled
			1	TCNT cleared by TGRA compare match/input capture
			1	TCNT cleared by counter clearing for another channel performing synchronous clearing/synchronous operation* <sup>1</sup>

Notes: 1. Synchronous operation setting is performed by setting the SYNC bit in TSYR to 1.

2. Bit 7 is reserved in channels 1 and 2. It is always read as 0 and cannot be modified.



**Table 9.5 TPSC2 to TPSC0 (channel 0)**

Channel	Bit 2	Bit 1	Bit 0	Description
	TPSC2	TPSC1	TPSC0	
0	0	0	0	Internal clock: counts on $\phi/1$
			1	Internal clock: counts on $\phi/4$
		1	0	Internal clock: counts on $\phi/16$
			1	Internal clock: counts on $\phi/64$
	1	0	0	External clock: counts on TCLKA pin input
			1	External clock: counts on TCLKB pin input
		1	0	External clock: counts on TCLKC pin input
			1	External clock: counts on TCLKD pin input

**Table 9.6 TPSC2 to TPSC0 (channel 1)**

Channel	Bit 2	Bit 1	Bit 0	Description
	TPSC2	TPSC1	TPSC0	
1	0	0	0	Internal clock: counts on $\phi/1$
			1	Internal clock: counts on $\phi/4$
		1	0	Internal clock: counts on $\phi/16$
			1	Internal clock: counts on $\phi/64$
	1	0	0	External clock: counts on TCLKA pin input
			1	External clock: counts on TCLKB pin input
		1	0	Internal clock: counts on $\phi/256$
			1	Setting prohibited

Note: This setting is ignored when channel 1 is in phase counting mode.

**Table 9.7 TPSC2 to TPSC0 (channel 2)**

Channel	Bit 2	Bit 1	Bit 0	Description
	TPSC2	TPSC1	TPSC0	
2	0	0	0	Internal clock: counts on $\phi/1$
			1	Internal clock: counts on $\phi/4$
		1	0	Internal clock: counts on $\phi/16$
			1	Internal clock: counts on $\phi/64$
	1	0	0	External clock: counts on TCLKA pin input
			1	External clock: counts on TCLKB pin input
		1	0	External clock: counts on TCLKC pin input
			1	Internal clock: counts on $\phi/1024$

Note: This setting is ignored when channel 1 is in phase counting mode.

### 9.3.2 Timer Mode Register (TMDR)

The TMDR registers are used to set the operating mode for each channel. The TPU has three TMDR registers, one for each channel. TMDR register settings should be made only when TCNT operation is stopped.

Bit	Bit Name	Initial value	R/W	Description
7, 6	—	All 1	—	Reserved These bits are always read as 1 and cannot be modified.
5	BFB	0	R/W	Buffer Operation B Specifies whether TGRB is to operate in the normal way, or TGRB and TGRD are to be used together for buffer operation. When TGRD is used as a buffer register. TGRD input capture/output compare is not generation. In channels 1 and 2, which have no TGRD, bit 5 is reserved. It is always read as 0 and cannot be modified. 0: TGRB operates normally 1: TGRB and TGRD used together for buffer operation

Bit	Bit Name	Initial value	R/W	Description
4	BFA	0	R/W	Buffer Operation A Specifies whether TGRA is to operate in the normal way, or TGRA and TGRC are to be used together for buffer operation. When TGRC is used as a buffer register, TGRC input capture/output compare is not generated. In channels 1 and 2, which have no TGRC, bit 4 is reserved. It is always read as 0 and cannot be modified. 0: TGRA operates normally 1: TGRA and TGRC used together for buffer operation
3	MD3	0	R/W	Modes 3 to 0
2	MD2	0	R/W	These bits are used to set the timer operating mode.
1	MD1	0	R/W	MD3 is a reserved bit. In a write, the write value should always be 0. See table 9.8, for details.
0	MD0	0	R/W	

Table 9.8 MD3 to MD0

Bit 3	Bit 2	Bit 1	Bit 0	Description		
MD3* <sup>1</sup>	MD2* <sup>2</sup>	MD1	MD0			
0	0	0	0	Normal operation		
			1	Reserved		
		1	0	PWM mode 1		
			1	PWM mode 2		
		1	0	0	0	Phase counting mode 1
					1	Phase counting mode 2
				1	0	Phase counting mode 3
					1	Phase counting mode 4
1	x	x	x	—		

Legend:

x: Don't care

Notes: 1. MD3 is reserved bit. In a write, it should be written with 0.

2. Phase counting mode cannot be set for channels 0 and 3. In this case, 0 should always be written to MD2.

### 9.3.3 Timer I/O Control Register (TIOR)

The TIOR registers control the TGR registers. The TPU has eight TIOR registers, two each for channels 0, and one each for channels 1 and 2. Care is required since TIOR is affected by the TMDR setting. The initial output specified by TIOR is valid when the counter is stopped (the CST bit in TSTR is cleared to 0). Note also that, in PWM mode 2, the output at the point at which the counter is cleared to 0 is specified. When TGRC or TGRD is designated for buffer operation, this setting is invalid and the register operates as a buffer register.

- **TIORH\_0, TIOR\_1, TIOR\_2**

Bit	Bit Name	Initial value	R/W	Description
7	IOB3	0	R/W	I/O Control B3 to B0
6	IOB2	0	R/W	Specify the function of TGRB.
5	IOB1	0	R/W	
4	IOB0	0	R/W	
3	IOA3	0	R/W	I/O Control A3 to A0
2	IOA2	0	R/W	Specify the function of TGRA.
1	IOA1	0	R/W	
0	IOA0	0	R/W	

- **TIORL\_0**

Bit	Bit Name	Initial value	R/W	Description
7	IOD3	0	R/W	I/O Control D3 to D0
6	IOD2	0	R/W	Specify the function of TGRD.
5	IOD1	0	R/W	
4	IOD0	0	R/W	
3	IOC3	0	R/W	I/O Control C3 to C0
2	IOC2	0	R/W	Specify the function of TGRC.
1	IOC1	0	R/W	
0	IOC0	0	R/W	

Table 9.9 TIORH\_0 (channel 0)

				Description	
Bit 7	Bit 6	Bit 5	Bit 4	TGRB_0	
IOB3	IOB2	IOB1	IOB0	Function	TIOCBO Pin Function
0	0	0	0	Output compare register	Output disabled
			1		Initial output is 0 output 0 output at compare match
		1	0	Initial output is 0 output 1 output at compare match	
			1	Initial output is 0 output Toggle output at compare match	
	1	0	0	Input capture register	Output disabled
			1		Initial output is 1 output 0 output at compare match
		1	0	Initial output is 1 output 1 output at compare match	
			1	Initial output is 1 output Toggle output at compare match	
1	0	0	Input capture register	Capture input source is TIOCBO pin Input capture at rising edge	
		1		Capture input source is TIOCBO pin Input capture at falling edge	
		1		Capture input source is TIOCBO pin Input capture at both edges	
1	1	×	×		Setting prohibited

Legend:

×: Don't care

Table 9.10 TIORH\_0 (channel 0)

				Description	
Bit 3	Bit 2	Bit 1	Bit 0	TGRA_0	
IOA3	IOA2	IOA1	IOA0	Function	TIOCA0 Pin Function
0	0	0	0	Output compare register	Output disabled
			1		Initial output is 0 output 0 output at compare match
		1	0	Initial output is 0 output 1 output at compare match	
			1	Initial output is 0 output Toggle output at compare match	
	1	0	0	Output compare register	Output disabled
			1		Initial output is 1 output 0 output at compare match
		1	0	Initial output is 1 output 1 output at compare match	
			1	Initial output is 1 output Toggle output at compare match	
1	0	0	0	Input capture register	Capture input source is TIOCA0 pin Input capture at rising edge
			1		Capture input source is TIOCA0 pin Input capture at falling edge
		1	x	Capture input source is TIOCA0 pin Input capture at both edges	
	1	x	x		Setting prohibited

Legend:

x: Don't care

Table 9.11 TIORL\_0 (channel 0)

				Description		
Bit 7	Bit 6	Bit 5	Bit 4	TGRD_0		
IOD3	IOD2	IOD1	IOD0	Function	TIOCD0 Pin Function	
0	0	0	0	Output	Output disabled	
			1	Compare register*	Initial output is 0 output 0 output at compare match	
		1	0		Initial output is 0 output 1 output at compare match	
			1		Initial output is 0 output Toggle output at compare match	
	1	0	0		Output disabled	
			1		Initial output is 1 output 0 output at compare match	
		1	0		Initial output is 1 output	
			1		Initial output is 1 output Toggle output at compare match	
	1	0	0	0	Input capture register*	Capture input source is TIOCD0 pin Input capture at rising edge
				1		Capture input source is TIOCD0 pin Input capture at falling edge
			1	×	Capture input source is TIOCD0 pin Input capture at both edges	
		1	×	×		Setting prohibited

Legend:

×: Don't care

Note: \* When the BFB bit in TMDR\_0 is set to 1 and TGRD\_0 is used as a buffer register, this setting is invalid and input capture/output compare is not generated.

Table 9.12 TIORL\_0 (channel 0)

				Description	
Bit 3	Bit 2	Bit 1	Bit 1	TGRC_0	
IOC3	IOC2	IOC1	IOC0	Function	TIOCC0 Pin Function
0	0	0	0	Output compare register*	Output disabled
			1		Initial output is 0 output 0 output at compare match
		1	0	1	Initial output is 0 output 1 output at compare match
			1		Initial output is 0 output Toggle output at compare match
	1	0	0	1	Output disabled
			1		Initial output is 1 output 0 output at compare match
		1	0	1	Initial output is 1 output 1 output at compare match
			1		Initial output is 1 output Toggle output at compare match
1	0	0	Input capture register*	Capture input source is TIOCC0 pin Input capture at rising edge	
		1		Capture input source is TIOCC0 pin Input capture at falling edge	
	1	1	×	Capture input source is TIOCC0 pin Input capture at both edges	
		×		Setting prohibited	

Legend:

×: Don't care

Note: \* When the BFA bit in TMDR\_0 is set to 1 and TGRC\_0 is used as a buffer register, this setting is invalid and input capture/output compare is not generated.



Table 9.13 TIOR\_1 (channel 1)

				Description	
Bit 7	Bit 6	Bit 5	Bit 4	TGRB_1	
IOB3	IOB2	IOB1	IOB0	Function	TIOCB1 Pin Function
0	0	0	0	Output compare register	Output disabled
			1		Initial output is 0 output 0 output at compare match
		1	0		Initial output is 0 output 1 output at compare match
			1		Initial output is 0 output Toggle output at compare match
	1	0	0	Output disabled	
			1	Initial output is 1 output 0 output at compare match	
		1	0	Initial output is 1 output 1 output at compare match	
			1	Initial output is 1 output Toggle output at compare match	
1	0	0	Input capture register	Capture input source is TIOCB1 pin Input capture at rising edge	
		1		Capture input source is TIOCB1 pin Input capture at falling edge	
	1	×		Capture input source is TIOCB1 pin Input capture at both edges	
		1		×	Setting prohibited

Legend:

×: Don't care

Table 9.14 TIOR\_1 (channel 1)

				Description	
Bit 3	Bit 2	Bit 1	Bit 0	TGRA_1	
IOA3	IOA2	IOA1	IOA0	Function	TIOCA1 Pin Function
0	0	0	0	Output compare register	Output disabled
			1		Initial output is 0 output 0 output at compare match
		1	0	Initial output is 0 output 1 output at compare match	
			1	Initial output is 0 output Toggle output at compare match	
	1	0	0	Input capture register	Output disabled
			1		Initial output is 1 output 0 output at compare match
		1	0	Initial output is 1 output 1 output at compare match	
			1	Initial output is 1 output Toggle output at compare match	
1	0	0	Input capture register	Capture input source is TIOCA1 pin Input capture at rising edge	
		1		Capture input source is TIOCA1 pin Input capture at falling edge	
	1	1	×	Capture input source is TIOCA1 pin Input capture at both edges	
		1	×	×	Setting prohibited

Legend:

×: Don't care

Table 9.15 TIOR\_2 (channel 2)

				Description	
Bit 7	Bit 6	Bit 5	Bit 4	TGRB_2	
IOB3	IOB2	IOB1	IOB0	Function	TIOCB2 Pin Function
0	0	0	0	Output compare register	Output disabled
			1		Initial output is 0 output 0 output at compare match
		1	0		Initial output is 0 output 1 output at compare match
			1		Initial output is 0 output Toggle output at compare match
	1	0	0	Output disabled	
			1	Initial output is 1 output 0 output at compare match	
		1	0	Initial output is 1 output 1 output at compare match	
			1	Initial output is 1 output Toggle output at compare match	
1	×	0	0	Input capture register	Capture input source is TIOCB2 pin Input capture at rising edge
			1		Capture input source is TIOCB2 pin Input capture at falling edge
	1	×	1	Capture input source is TIOCB2 pin Input capture at both edges	

Legend:

×: Don't care

Table 9.16 TIOR\_2 (channel 2)

Bit 3	Bit 2	Bit 1	Bit 0	Description	
				TGRA_2	TIOCA2 Pin Function
IOA3	IOA2	IOA1	IOA0	Function	
0	0	0	0	Output compare register	Output disabled
			1		Initial output is 0 output 0 output at compare match
		1	0		Initial output is 0 output 1 output at compare match
			1		Initial output is 0 output Toggle output at compare match
	1	0	0		Output disabled
			1		Initial output is 1 output 0 output at compare match
		1	0		Initial output is 1 output 1 output at compare match
			1		Initial output is 1 output Toggle output at compare match
1	×	0	0	Input capture register	Capture input source is TIOCA2 pin Input capture at rising edge
			1		Capture input source is TIOCA2 pin Input capture at falling edge
			1		×

Legend:

×: Don't care

### 9.3.4 Timer Interrupt Enable Register (TIER)

The TIER registers control enabling or disabling of interrupt requests for each channel. The TPU has three TIER registers, one for each channel.

Bit	Bit Name	Initial value	R/W	Description
7	TTGE	0	R/W	A/D Conversion Start Request Enable Enables or disables generation of A/D conversion start requests by TGRA input capture/compare match. 0: A/D conversion start request generation disabled 1: A/D conversion start request generation enabled
6	–	1	–	Reserved This bit is always read as 1 and cannot be modified.
5	TCIEU	0	R/W	Underflow Interrupt Enable Enables or disables interrupt requests (TCU) by the TCFU flag when the TCFU flag in TSR is set to 1 in channels 1 and 2. In channel 0, bit 5 is reserved. 0: Interrupt requests (TCIU) by TCFU disabled 1: Interrupt requests (TCIU) by TCFU enabled
4	TCIEV	0	R/W	Overflow Interrupt Enable Enables or disables interrupt requests (TCIV) by the TCFV flag when the TCFV flag in TSR is set to 1. 0: Interrupt requests (TCIV) by TCFV disabled 1: Interrupt requests (TCIV) by TCFV enabled
3	TGIED	0	R/W	TGR Interrupt Enable D Enables or disables interrupt requests (TGID) by the TGFD bit when the TGFD bit in TSR is set to 1 in channel 0. In channels 1 and 2, bit 3 is reserved. It is always read as 0 and cannot be modified. 0: Interrupt requests (TGID) by TGFD disabled 1: Interrupt requests (TGID) by TGFD enabled.
2	TGIEC	0	R/W	TGR Interrupt Enable C Enables or disables interrupt requests (TGIC) by the TGFC bit when the TGFC bit in TSR is set to 1 in channel 0. In channels 1 and 2, bit 2 is reserved. It is always read as 0 and cannot be modified. 0: Interrupt requests (TGIC) by TGFC disabled 1: Interrupt requests (TGIC) by TGFC enabled

Bit	Bit Name	Initial value	R/W	Description
1	TGIEB	0	R/W	TGR Interrupt Enable B Enables or disables interrupt requests (TGIB) by the TGFB bit when the TGFB bit in TSR is set to 1. 0: Interrupt requests (TGIB) by TGFB disabled 1: Interrupt requests (TGIB) by TGFB enabled
0	TGIEA	0	R/W	TGR Interrupt Enable A Enables or disables interrupt requests (TGIA) by the TGFA bit when the TGFA bit in TSR is set to 1. 0: Interrupt requests (TGIA) by TGFA disabled 1: Interrupt requests (TGIA) by TGFA enabled

### 9.3.5 Timer Status Register (TSR)

The TSR registers indicate the status of each channel. The TPU has three TSR registers, one for each channel.

Bit	Bit Name	Initial value	R/W	Description
7	TCFD	1	R	Count Direction Flag Status flag that shows the direction in which TCNT counts in channel 1 and 2. In channel 0, bit 7 is reserved. It is always read as 0 and cannot be modified. 0: TCNT counts down 1: TCNT counts up
6	–	1	–	Reserved This bit is always read as 1 and cannot be modified.
5	TCFU	0	R/(W)*	Underflow Flag Status flag that indicates that TCNT underflow has occurred when channels 1 and 2 are set to phase counting mode. The write value should always be 0 to clear this flag. In channel 0, bit 5 is reserved. [Setting condition] When the TCNT value underflows (change from H'0000 to H'FFFF) [Clearing condition] When 0 is written to TCFU after reading TCFU = 1

Bit	Bit Name	Initial value	R/W	Description
4	TCFV	0	R/(W)*	<p>Overflow Flag</p> <p>Status flag that indicates that TCNT overflow has occurred. The write value should always be 0 to clear this flag.</p> <p>[Setting condition] When the TCNT value overflows (change from H'FFFF to H'0000)</p> <p>[Clearing condition] When 0 is written to TCFV after reading TCFV = 1</p>
3	TGFD	0	R/(W)*	<p>Input Capture/Output Compare Flag D</p> <p>Status flag that indicates the occurrence of TGRD input capture or compare match in channel 0. The write value should always be 0 to clear this flag. In channels 1 and 2, bit 3 is reserved. It is always read as 0 and cannot be modified.</p> <p>[Setting conditions]</p> <ul style="list-style-type: none"> <li>• When TCNT = TGRD while TGRD is functioning as output compare register</li> <li>• When TCNT value is transferred to TGRD by input capture signal while TGRD is functioning as input capture register</li> </ul> <p>[Clearing condition] When 0 is written to TGFD after reading TGFD = 1</p>
2	TGFC	0	R/(W)*	<p>Input Capture/Output Compare Flag C</p> <p>Status flag that indicates the occurrence of TGRC input capture or compare match in channel 0. The write value should always be 0 to clear this flag. In channels 1 and 2, bit 2 is reserved. It is always read as 0 and cannot be modified.</p> <p>[Setting conditions]</p> <ul style="list-style-type: none"> <li>• When TCNT = TGRC while TGRC is functioning as output compare register</li> <li>• When TCNT value is transferred to TGRC by input capture signal while TGRC is functioning as input capture register</li> </ul> <p>[Clearing condition] When 0 is written to TGFC after reading TGFC = 1</p>

Bit	Bit Name	Initial value	R/W	Description
1	TGFB	0	R/(W)*	<p>Input Capture/Output Compare Flag B</p> <p>Status flag that indicates the occurrence of TGRB input capture or compare match. The write value should always be 0 to clear this flag.</p> <p>[Setting conditions]</p> <ul style="list-style-type: none"> <li>• When TCNT = TGRB while TGRB is functioning as output compare register</li> <li>• When TCNT value is transferred to TGRB by input capture signal while TGRB is functioning as input capture register</li> </ul> <p>[Clearing condition]</p> <p>When 0 is written to TGFB after reading TGFB = 1</p>
0	TGFA	0	R/(W)*	<p>Input Capture/Output Compare Flag A</p> <p>Status flag that indicates the occurrence of TGRA input capture or compare match. The write value should always be 0 to clear this flag.</p> <p>[Setting conditions]</p> <ul style="list-style-type: none"> <li>• When TCNT = TGRA while TGRA is functioning as output compare register</li> <li>• When TCNT value is transferred to TGRA by input capture signal while TGRA is functioning as input capture register</li> </ul> <p>[Clearing conditions]</p> <ul style="list-style-type: none"> <li>• When DMAC is activated by TGIA interrupt while DTA bit of DMABCR in DMAC is 1</li> <li>• When 0 is written to TGFA after reading TGFA = 1</li> </ul>

Note: \* Only 0 can be written to clear the flags.



### 9.3.6 Timer Counter (TCNT)

The TCNT registers are 16-bit counters. The TPU has three TCNT counters, one for each channel. The TCNT counters are initialized to H'0000 by a reset, and in hardware standby mode. The TCNT counters cannot be accessed in 8-bit units; they must always be accessed as a 16-bit unit.

### 9.3.7 Timer General Register (TGR)

The TGR registers are 16-bit registers with a dual function as output compare and input capture registers. The TPU has 16 TGR registers, four each for channel 0 and two each for channels 1 and 2. TGRC and TGRD for channel 0 can also be designated for operation as buffer registers. The TGR registers cannot be accessed in 8-bit units; they must always be accessed as a 16-bit unit. TGR buffer register combinations are TGRA—TGRC and TGRB—TGRD.

### 9.3.8 Timer Start Register (TSTR)

TSTR is an 8-bit readable/writable register that selects operation/stoppage for channels 0 to 2. When setting the operating mode in TMDR or setting the count clock in TCR, first stop the TCNT counter.

Bit	Bit Name	Initial Value	R/W	Description
7 to 3	—	All 0	—	Reserved The write value should always be 0.
2	CST2	0	R/W	Counter Start 2 to 0 (CST2 to CST0)
1	CST1	0	R/W	These bits select operation or stoppage for TCNT.
0	CST0	0	R/W	If 0 is written to the CST bit during operation with the TIOC pin designated for output, the counter stops but the TIOC pin output compare output level is retained. If TIOR is written to when the CST bit is cleared to 0, the pin output level will be changed to the set initial output value. 0: TCNT_2 to TCNT_0 count operation is stopped 1: TCNT_2 to TCNT_0 performs count operation

### 9.3.9 Timer Synchro Register (TSYR)

TSYR selects independent operation or synchronous operation for the channel 0 to 2 TCNT counters. A channel performs synchronous operation when the corresponding bit in TSYR is set to 1.

Bit	Bit Name	Initial Value	R/W	Description
7 to 3	–	All 0	–	Reserved The write value should always be 0.
2	SYNC2	0	R/W	Timer Synchro 2 to 0
1	SYNC1	0	R/W	These bits select whether operation is independent of or synchronized with other channels. When synchronous operation is selected, synchronous presetting of multiple channels, and synchronous clearing through counter clearing on another channel are possible. To set synchronous operation, the SYNC bits for at least two channels must be set to 1. To set synchronous clearing, in addition to the SYNC bit, the TCNT clearing source must also be set by means of bits CCLR2 to CCLR0 in TCR. 0: TCNT_2 to TCNT_0 operates independently (TCNT presetting /clearing is unrelated to other channels) 1: TCNT_2 to TCNT_0 performs synchronous operation TCNT synchronous presetting/synchronous clearing is possible
0	SYNC0	0	R/W	

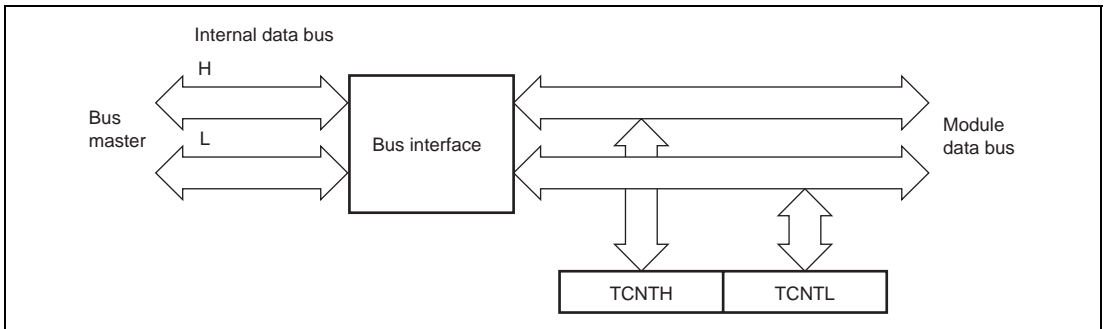
## 9.4 Interface to Bus Master

### 9.4.1 16-Bit Registers

TCNT and TGR are 16-bit registers. As the data bus to the bus master is 16 bits wide, these registers can be read and written to in 16-bit units.

These registers cannot be read from or written to in 8-bit units; 16-bit access must always be used.

An example of 16-bit register access operation is shown in figure 9.2.

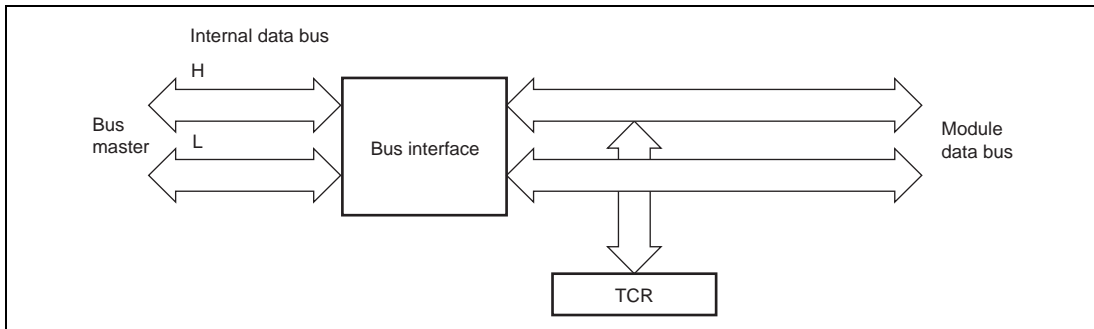


**Figure 9.2 16-Bit Register Access Operation [Bus Master ↔ TCNT (16 Bits)]**

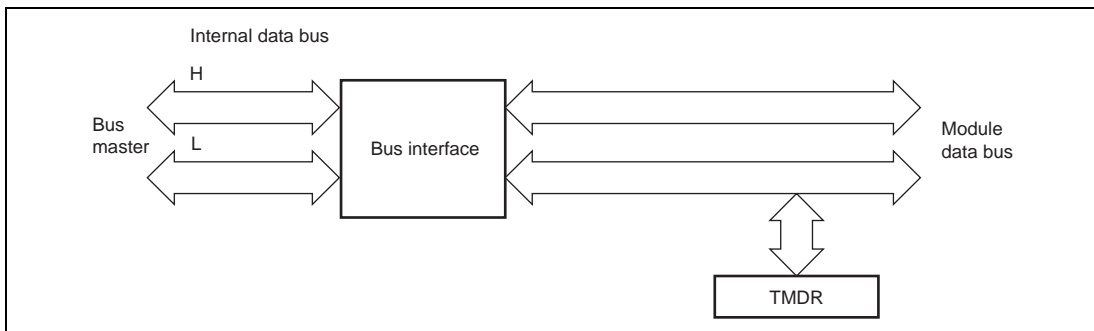
### 9.4.2 8-Bit Registers

Registers other than TCNT and TGR are 8-bit. As the data bus to the CPU is 16 bits wide, these registers can be read and written to in 16-bit units. They can also be read and written to in 8-bit units.

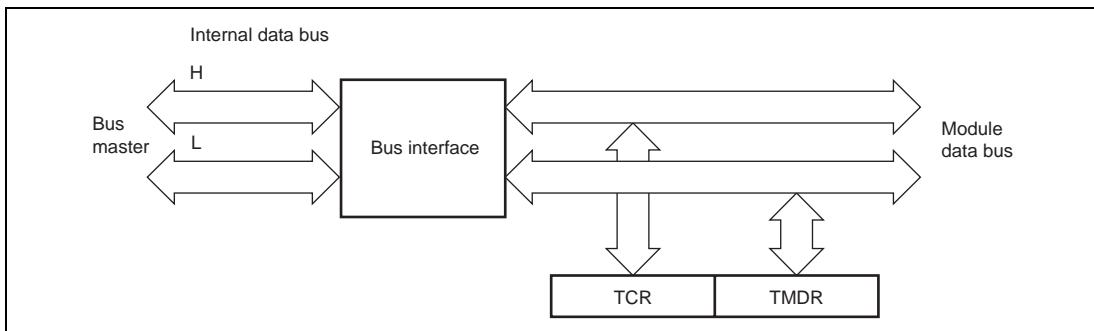
Examples of 8-bit register access operation are shown in figures 9.3 to 9.5.



**Figure 9.3 8-Bit Register Access Operation [Bus Master ↔ TCR (Upper 8 Bits)]**



**Figure 9.4 8-Bit Register Access Operation [Bus Master ↔ TMDR (Lower 8 Bits)]**



**Figure 9.5 8-Bit Register Access Operation [Bus Master ↔ TCR and TMDR (16 Bits)]**

## 9.5 Operation

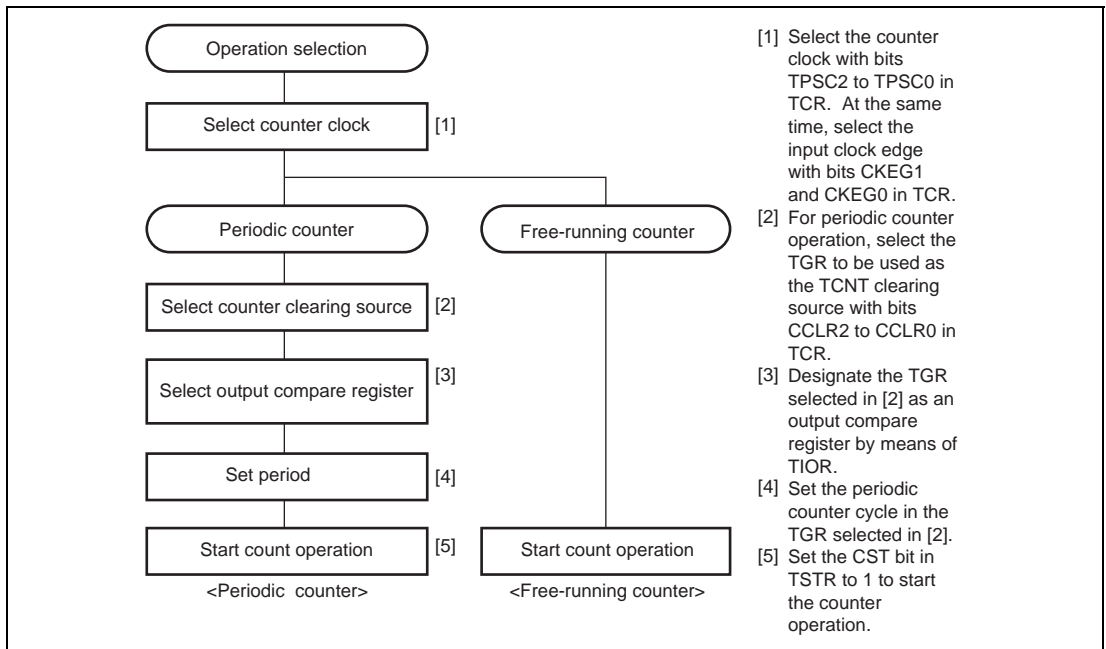
### 9.5.1 Basic Functions

Each channel has a TCNT and TGR. TCNT performs up-counting, and is also capable of free-running operation, synchronous counting, and external event counting. Each TGR can be used as an input capture register or output compare register.

**Counter Operation:** When one of bits CST0 to CST2 is set to 1 in TSTR, the TCNT counter for the corresponding channel starts counting. TCNT can operate as a free-running counter, periodic counter, and so on.

#### 1. Example of count operation setting procedure

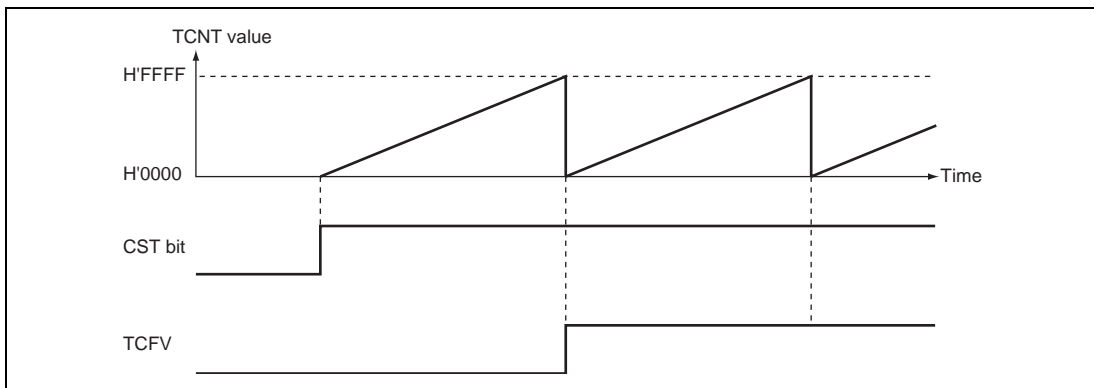
Figure 9.6 shows an example of the count operation setting procedure.



**Figure 9.6 Example of Counter Operation Setting Procedure**

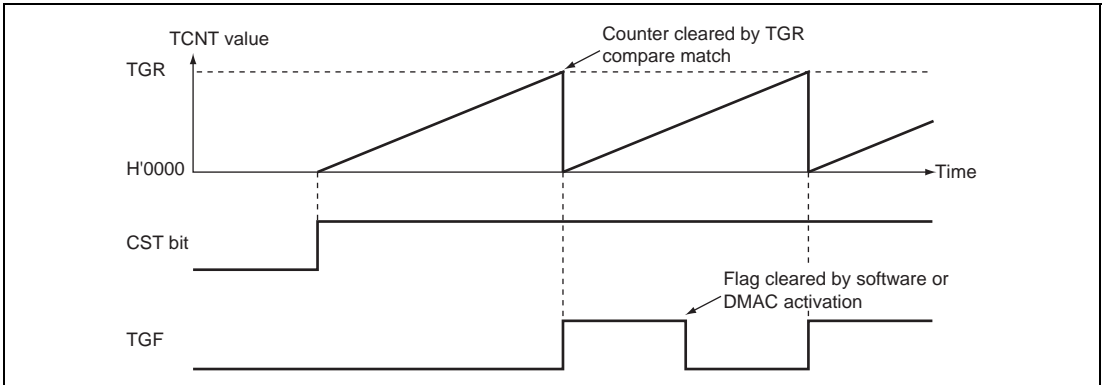
## 2. Free-running count operation and periodic count operation

Immediately after a reset, the TPU's TCNT counters are all designated as free-running counters. When the relevant bit in TSTR is set to 1 the corresponding TCNT counter starts up-count operation as a free-running counter. When TCNT overflows (from H'FFFF to H'0000), the TCFV bit in TSR is set to 1. If the value of the corresponding TCIEV bit in TIER is 1 at this point, the TPU requests an interrupt. After overflow, TCNT starts counting up again from H'0000. Figure 9.7 illustrates free-running counter operation.



**Figure 9.7 Free-Running Counter Operation**

When compare match is selected as the TCNT clearing source, the TCNT counter for the relevant channel performs periodic count operation. The TGR register for setting the period is designated as an output compare register, and counter clearing by compare match is selected by means of bits CCLR2 to CCLR0 in TCR. After the settings have been made, TCNT starts up-count operation as periodic counter when the corresponding bit in TSTR is set to 1. When the count value matches the value in TGR, the TGF bit in TSR is set to 1 and TCNT is cleared to H'0000. If the value of the corresponding TGIE bit in TIER is 1 at this point, the TPU requests an interrupt. After a compare match, TCNT starts counting up again from H'0000. Figure 9.8 illustrates periodic counter operation.

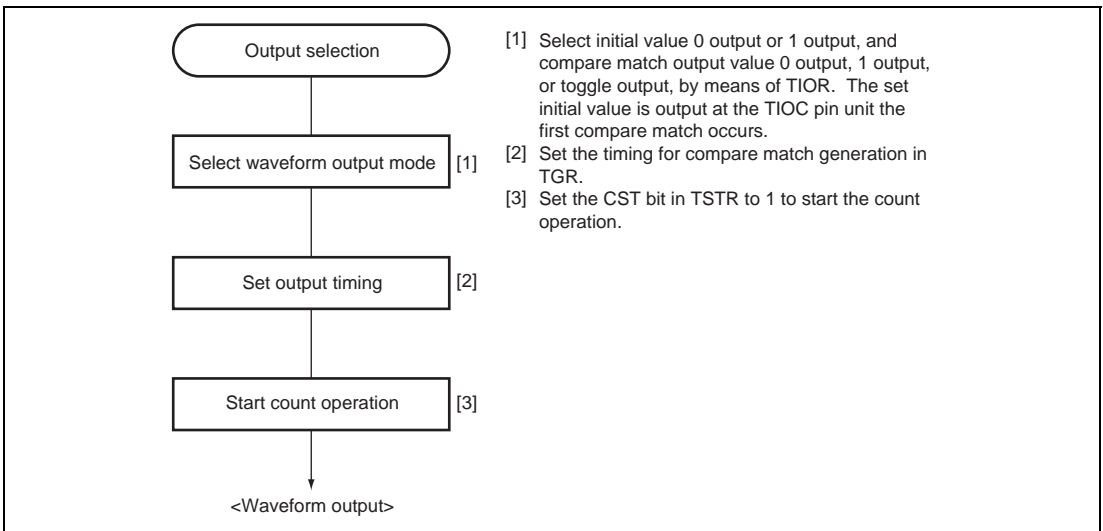


**Figure 9.8 Periodic Counter Operation**

**Waveform Output by Compare Match:** The TPU can perform 0, 1, or toggle output from the corresponding output pin using compare match.

1. Example of setting procedure for waveform output by compare match

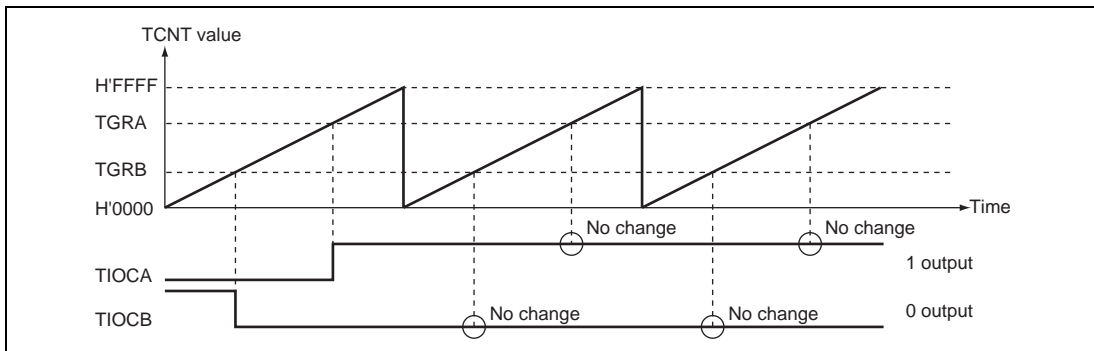
Figure 9.9 shows an example of the setting procedure for waveform output by compare match.



**Figure 9.9 Example of Setting Procedure for Waveform Output by Compare Match**

## 2. Examples of waveform output operation

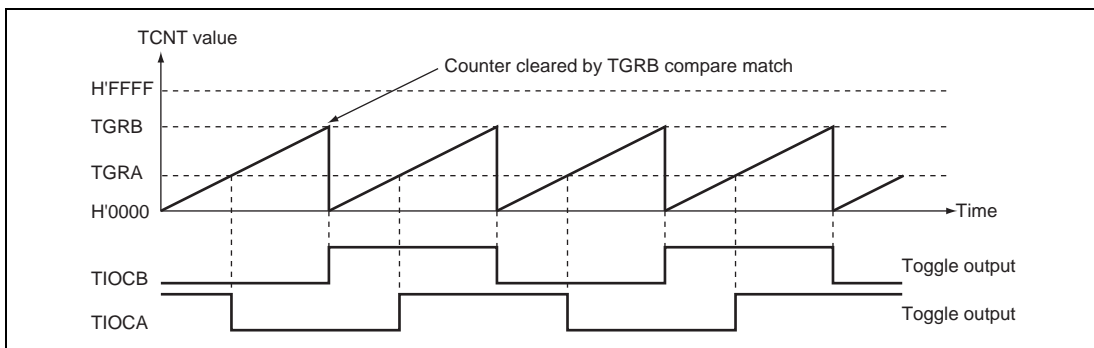
Figure 9.10 shows an example of 0 output/1 output. In this example TCNT has been designated as a free-running counter, and settings have been made so that 1 is output by compare match A, and 0 is output by compare match B. When the set level and the pin level coincide, the pin level does not change.



**Figure 9.10 Example of 0 Output/1 Output Operation**

Figure 9.11 shows an example of toggle output.

In this example TCNT has been designated as a periodic counter (with counter clearing performed by compare match B), and settings have been made so that output is toggled by both compare match A and compare match B.



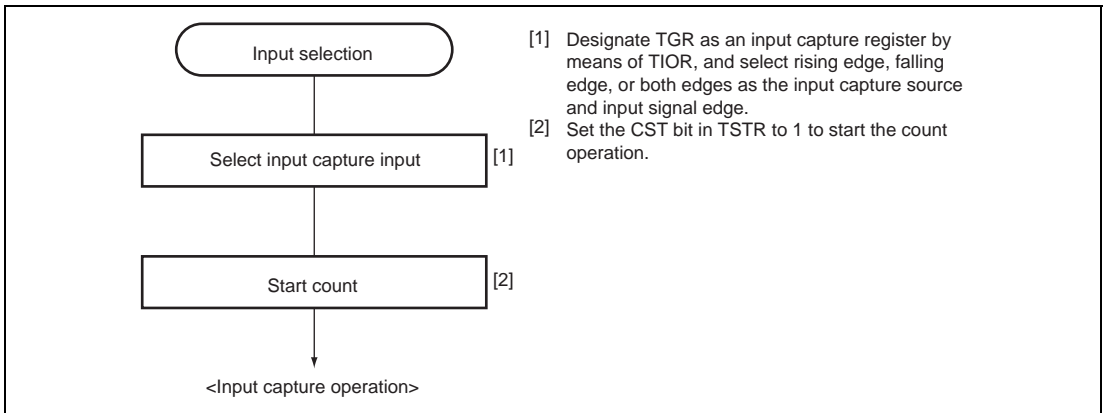
**Figure 9.11 Example of Toggle Output Operation**



**Input Capture Function:** The TCNT value can be transferred to TGR on detection of the TIOC pin input edge. Rising edge, falling edge, or both edges can be selected as the detected edge.

1. Example of input capture operation setting procedure

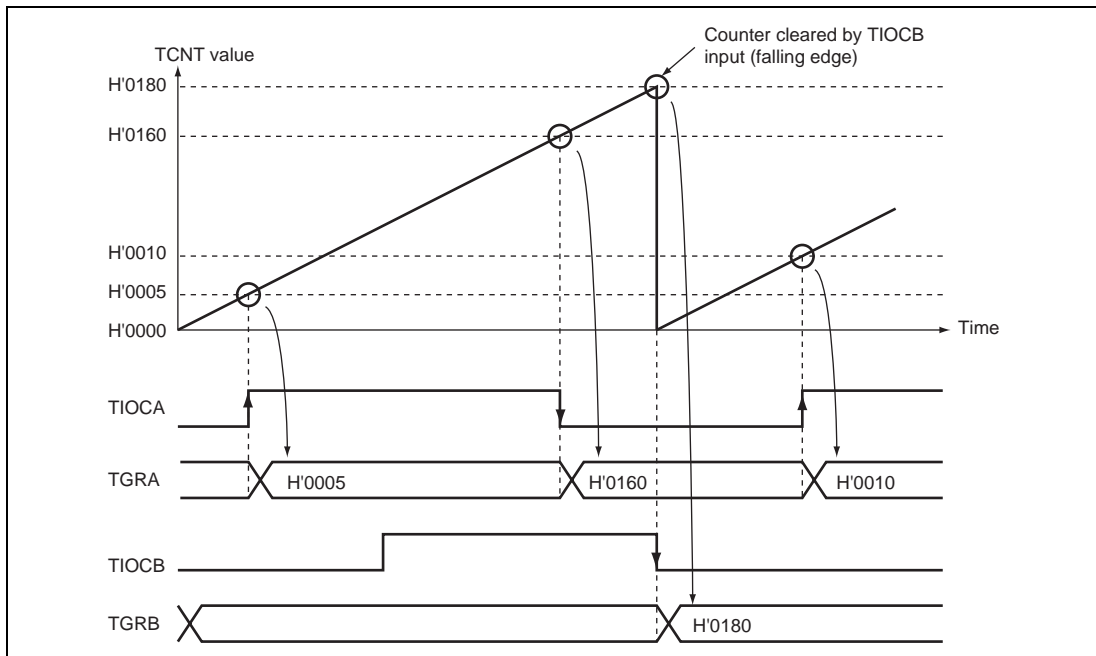
Figure 9.12 shows an example of the input capture operation setting procedure.



**Figure 9.12 Example of Input Capture Operation Setting Procedure**

## 2. Example of input capture operation

Figure 9.13 shows an example of input capture operation. In this example both rising and falling edges have been selected as the TIOCA pin input capture input edge, falling edge has been selected as the TIOCB pin input capture input edge, and counter clearing by TGRB input capture has been designated for TCNT.

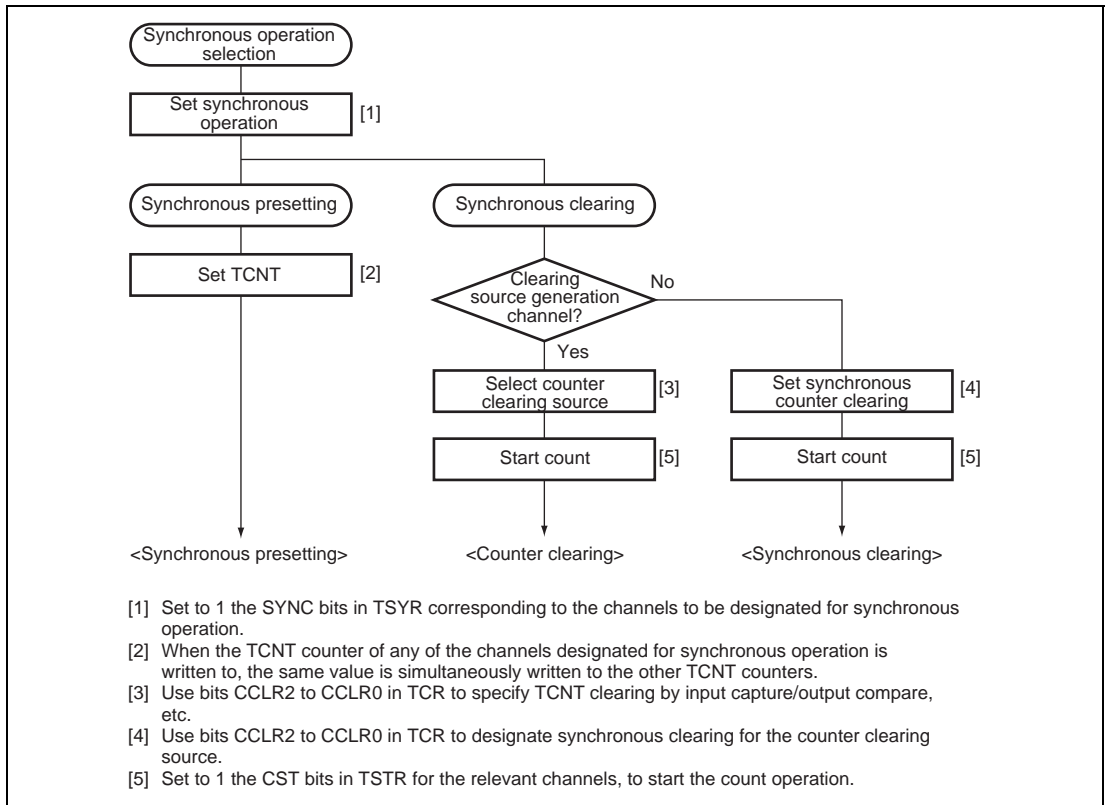


**Figure 9.13 Example of Input Capture Operation**

## 9.5.2 Synchronous Operation

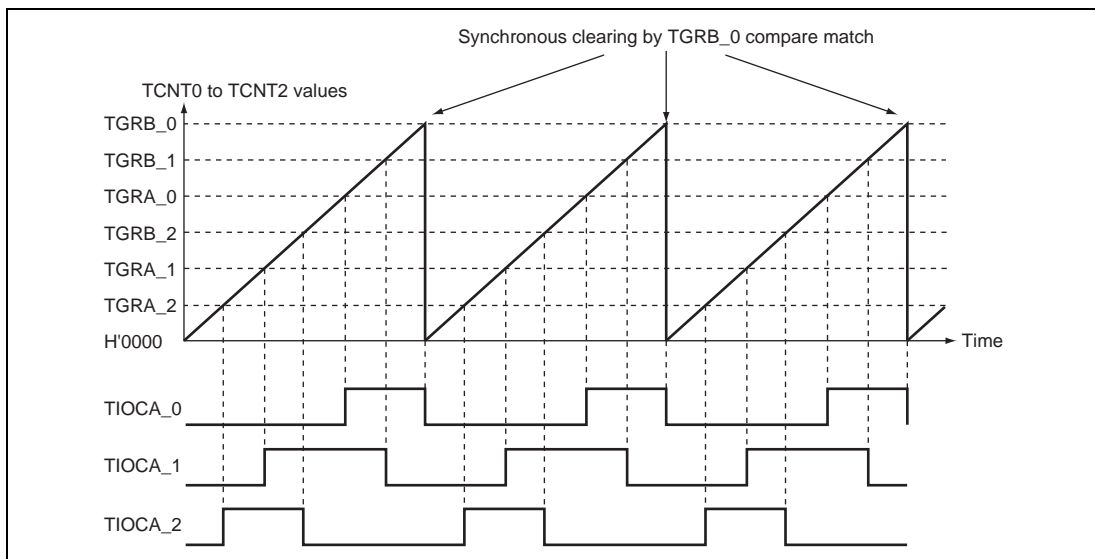
In synchronous operation, the values in a number of TCNT counters can be rewritten simultaneously (synchronous presetting). Also, a number of TCNT counters can be cleared simultaneously by making the appropriate setting in TCR (synchronous clearing). Synchronous operation enables TGR to be incremented with respect to a single time base. Channels 0 to 2 can all be designated for synchronous operation.

**Example of Synchronous Operation Setting Procedure:** Figure 9.14 shows an example of the synchronous operation setting procedure.



**Figure 9.14 Example of Synchronous Operation Setting Procedure**

**Example of Synchronous Operation:** Figure 9.15 shows an example of synchronous operation. In this example, synchronous operation and PWM mode 1 have been designated for channels 0 to 2, TGRB\_0 compare match has been set as the channel 0 counter clearing source, and synchronous clearing has been set for the channel 1 and 2 counter clearing source. Three-phase PWM waveforms are output from pins TIOC0A, TIOC1A, and TIOC2A. At this time, synchronous presetting, and synchronous clearing by TGRB\_0 compare match, is performed for channel 0 to 2 TCNT counters, and the data set in TGRB\_0 is used as the PWM cycle. For details of PWM modes, see section 9.5.4, PWM Modes.



**Figure 9.15 Example of Synchronous Operation**

### 9.5.3 Buffer Operation

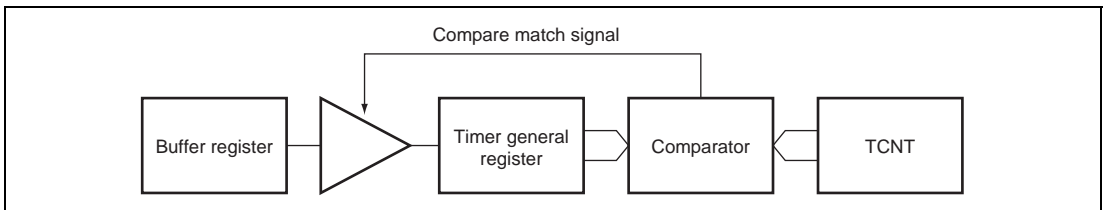
Buffer operation, provided for channel 0, enables TGRC and TGRD to be used as buffer registers. Buffer operation differs depending on whether TGR has been designated as an input capture register or as a compare match register. Table 9.17 shows the register combinations used in buffer operation.

**Table 9.17 Register Combinations in Buffer Operation**

Channel	Timer General Register	Buffer Register
0	TGRA_0	TGRC_0
	TGRB_0	TGRD_0

- When TGR is an output compare register

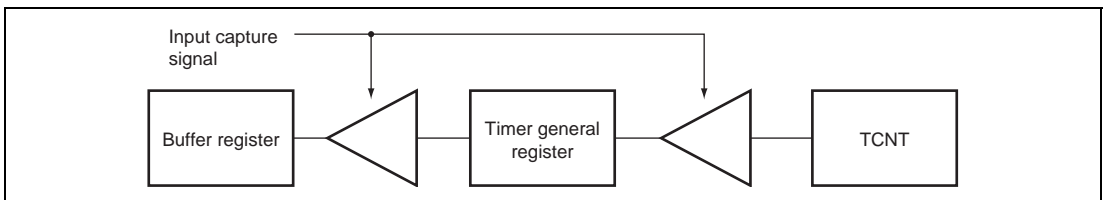
When a compare match occurs, the value in the buffer register for the corresponding channel is transferred to the timer general register. This operation is illustrated in figure 9.16.



**Figure 9.16 Compare Match Buffer Operation**

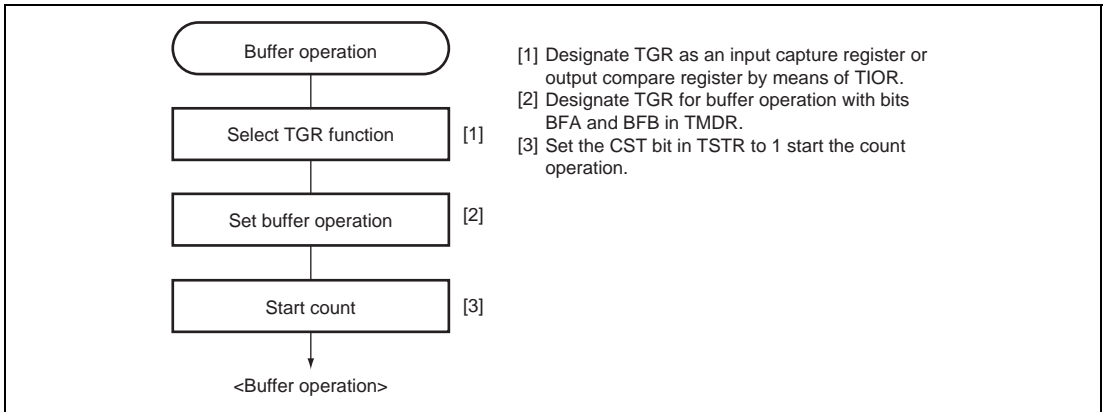
- When TGR is an input capture register

When input capture occurs, the value in TCNT is transferred to TGR and the value previously held in the timer general register is transferred to the buffer register. This operation is illustrated in figure 9.17.



**Figure 9.17 Input Capture Buffer Operation**

**Example of Buffer Operation Setting Procedure:** Figure 9.18 shows an example of the buffer operation setting procedure.

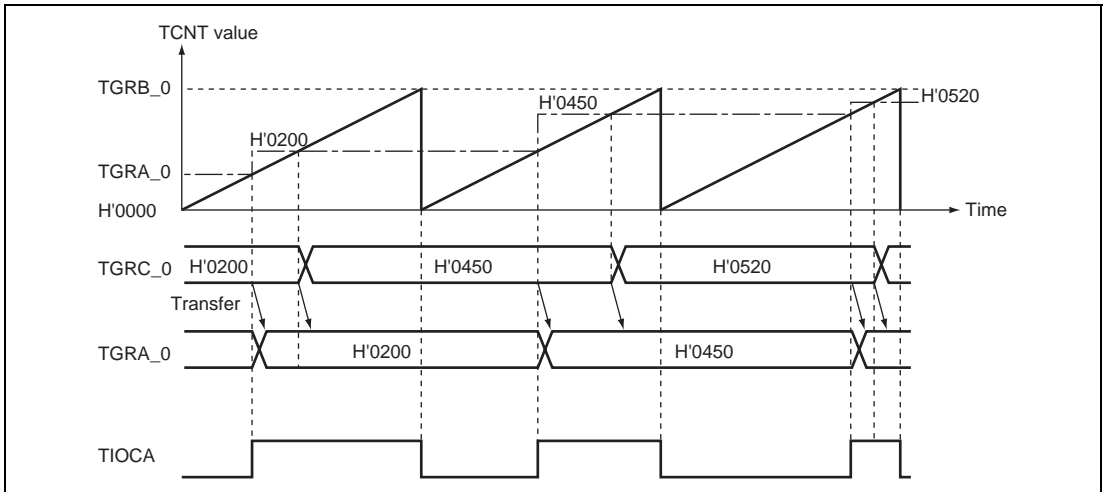


**Figure 9.18 Example of Buffer Operation Setting Procedure**

## Examples of Buffer Operation

### 1. When TGR is an output compare register

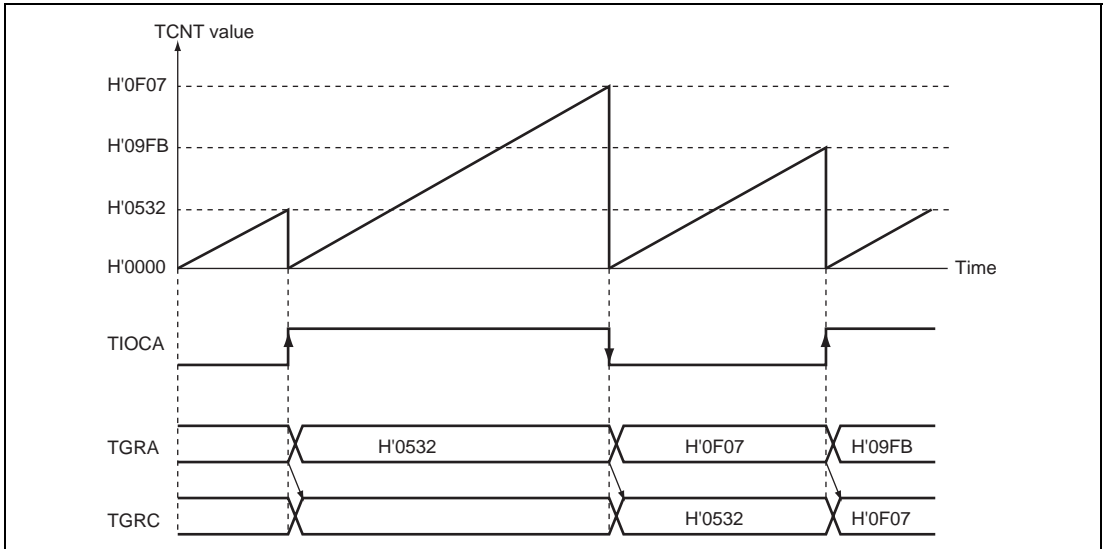
Figure 9.19 shows an operation example in which PWM mode 1 has been designated for channel 0, and buffer operation has been designated for TGRA and TGRC. The settings used in this example are TCNT clearing by compare match B, 1 output at compare match A, and 0 output at compare match B. As buffer operation has been set, when compare match A occurs the output changes and the value in buffer register TGRA is simultaneously transferred to timer general register TGRA. This operation is repeated each time compare match A occurs. For details of PWM modes, see section 9.5.4, PWM Modes.



**Figure 9.19 Example of Buffer Operation (1)**

## 2. When TGR is an input capture register

Figure 9.20 shows an operation example in which TGRA has been designated as an input capture register, and buffer operation has been designated for TGRA and TGRC. Counter clearing by TGRA input capture has been set for TCNT, and both rising and falling edges have been selected as the TIOCA pin input capture input edge. As buffer operation has been set, when the TCNT value is stored in TGRA upon occurrence of input capture A, the value previously stored in TGRA is simultaneously transferred to TGRC.



**Figure 9.20 Example of Buffer Operation (2)**



### 9.5.4 PWM Modes

In PWM mode, PWM waveforms are output from the output pins. 0, 1, or toggle output can be selected as the output level in response to compare match of each TGR. Settings of TGR registers can output a PWM waveform in the range of 0 % to 100 % duty. Designating TGR compare match as the counter clearing source enables the period to be set in that register. All channels can be designated for PWM mode independently. Synchronous operation is also possible. There are two PWM modes, as described below.

- PWM mode 1

PWM output is generated from the TIOCA and TIOCC pins by pairing TGRA with TGRB and TGRC with TGRD. The output specified by bits IOA3 to IOA0 and IOC3 to IOC0 in TIOR is output from the TIOCA and TIOCC pins at compare matches A and C, and the output specified by bits IOB3 to IOB0 and IOD3 to IOD0 in TIOR is output at compare matches B and D. The initial output value is the value set in TGRA or TGRC. If the set values of paired TGRs are identical, the output value does not change when a compare match occurs. In PWM mode 1, a maximum 4-phase PWM output is possible.

- PWM mode 2

PWM output is generated using one TGR as the cycle register and the others as duty registers. The output specified in TIOR is performed by means of compare matches. Upon counter clearing by a synchronization register compare match, the output value of each pin is the initial value set in TIOR. If the set values of the cycle and duty registers are identical, the output value does not change when a compare match occurs. In PWM mode 2, a maximum 7-phase PWM output is possible by combined use with synchronous operation. The correspondence between PWM output pins and registers is shown in table 9.18.

Table 9.18 PWM Output Registers and Output Pins

Channel	Registers	Output Pins	
		PWM Mode 1	PWM Mode 2
0	TGRA_0	TIOCA0	TIOCA0
	TGRB_0		TIOCB0
	TGRC_0	TIOCC0	TIOCC0
	TGRD_0		TIOCD0
1	TGRA_1	TIOCA1	TIOCA1
	TGRB_1		TIOCB1
2	TGRA_2	TIOCA2	TIOCA2
	TGRB_2		TIOCB2

Note: In PWM mode 2, PWM output is not possible for the TGR register in which the period is set.

**Example of PWM Mode Setting Procedure:** Figure 9.21 shows an example of the PWM mode setting procedure.

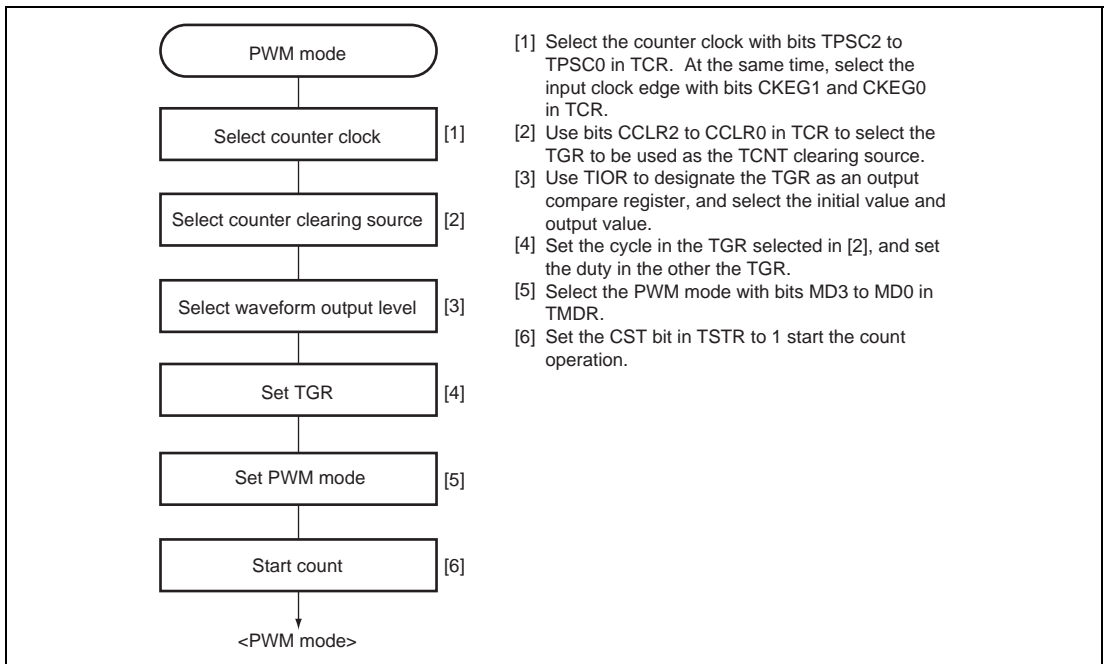
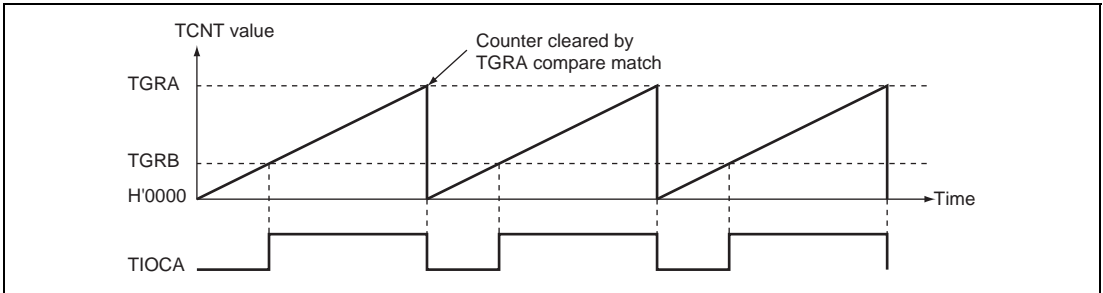


Figure 9.21 Example of PWM Mode Setting Procedure

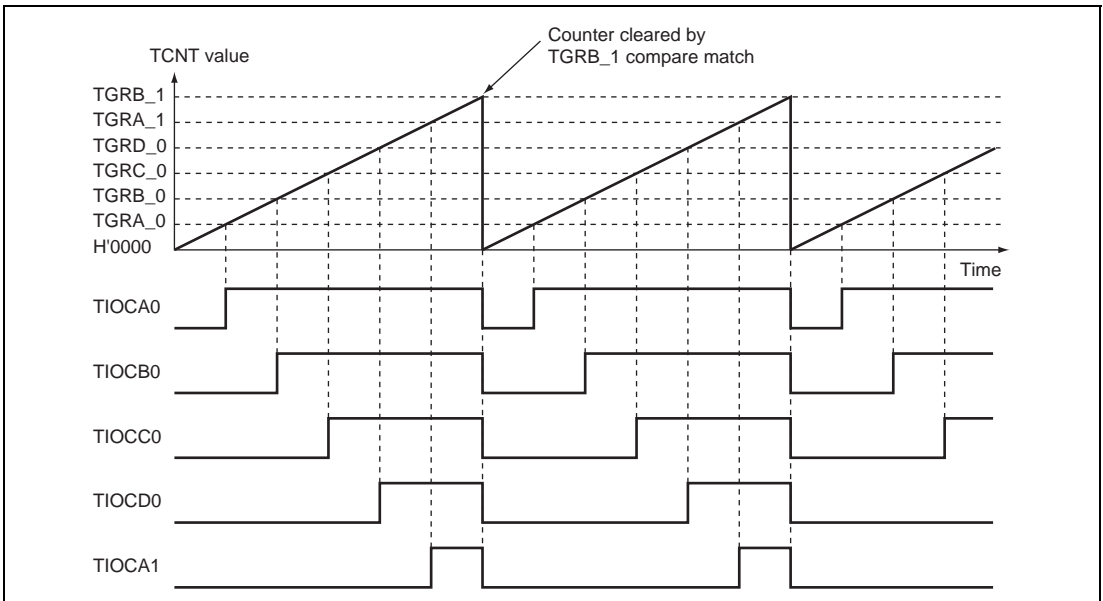
**Examples of PWM Mode Operation:** Figure 9.22 shows an example of PWM mode 1 operation.

In this example, TGRA compare match is set as the TCNT clearing source, 0 is set for the TGRA initial output value and output value, and 1 is set as the TGRB output value. In this case, the value set in TGRA is used as the period, and the values set in TGRB registers as the duty.



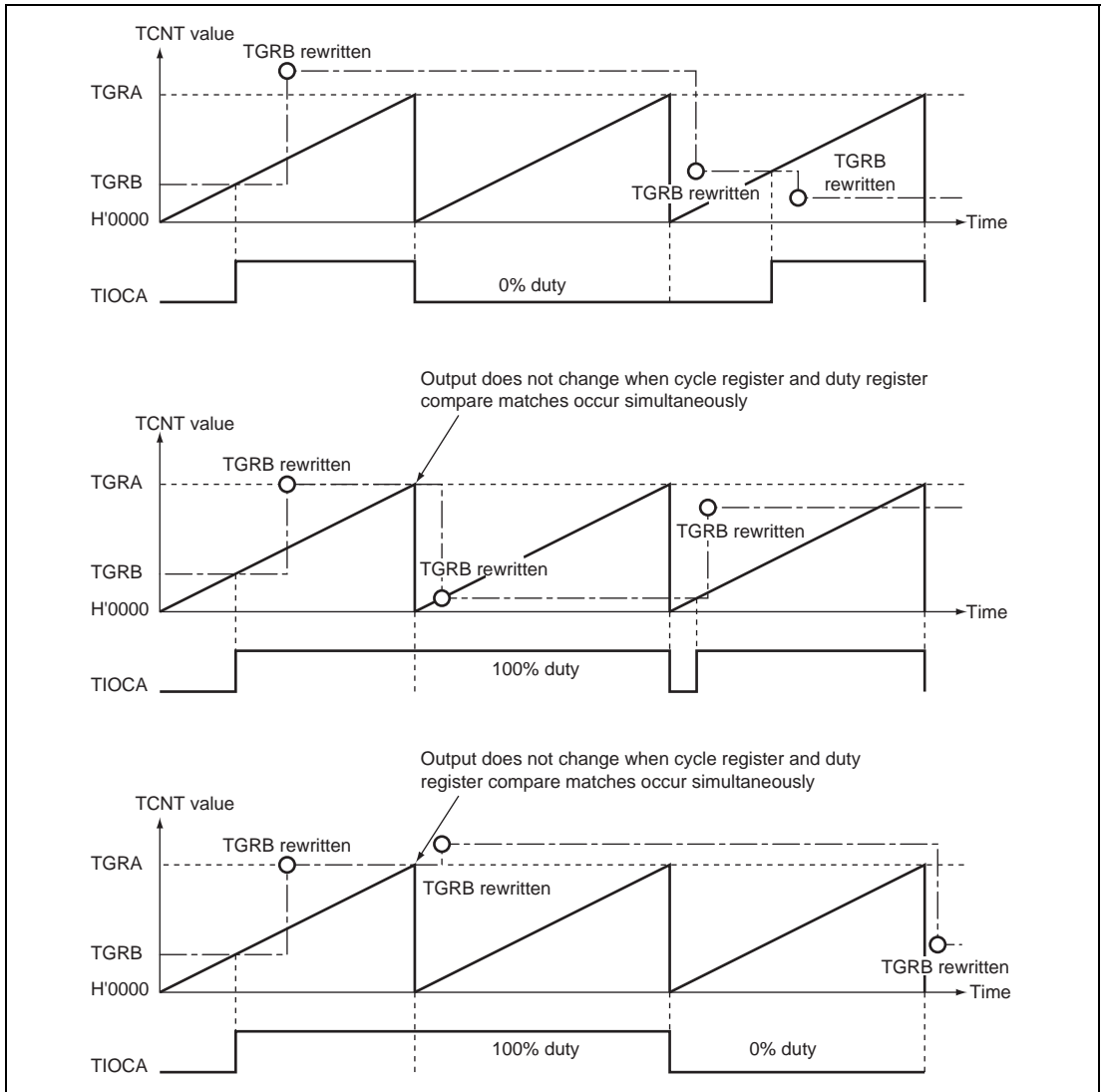
**Figure 9.22 Example of PWM Mode Operation (1)**

Figure 9.23 shows an example of PWM mode 2 operation. In this example, synchronous operation is designated for channels 0 and 1, TGRB\_1 compare match is set as the TCNT clearing source, and 0 is set for the initial output value and 1 for the output value of the other TGR registers (TGRA\_0 to TGRD\_0, TGRA\_1), to output a 5-phase PWM waveform. In this case, the value set in TGRB\_1 is used as the cycle, and the values set in the other TGRs as the duty.



**Figure 9.23 Example of PWM Mode Operation (2)**

Figure 9.24 shows examples of PWM waveform output with 0% duty and 100% duty in PWM mode.



**Figure 9.24 Example of PWM Mode Operation (3)**

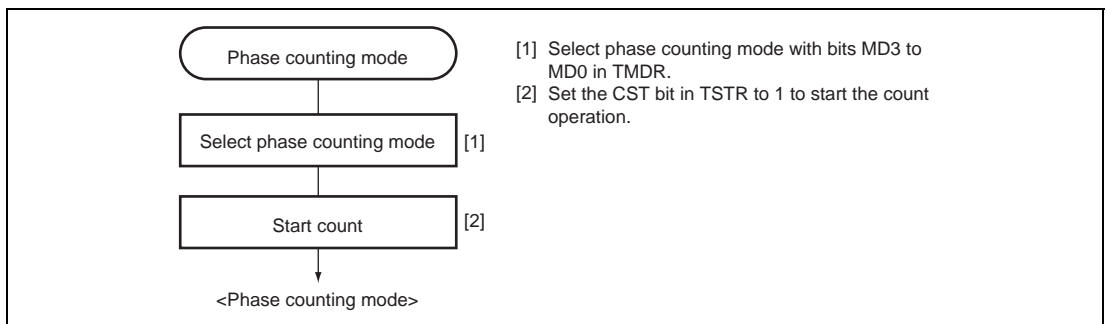
### 9.5.5 Phase Counting Mode

In phase counting mode, the phase difference between two external clock inputs is detected and TCNT is incremented/decremented accordingly. This mode can be set for channels 1 and 2. When phase counting mode is set, an external clock is selected as the counter input clock and TCNT operates as an up/down-counter regardless of the setting of bits TPSC2 to TPSC0 and bits CKEG1 and CKEG0 in TCR. However, the functions of bits CCLR1 and CCLR0 in TCR, and of TIOR, TIER, and TGR are valid, and input capture/compare match and interrupt functions can be used. This can be used for two-phase encoder pulse input. When overflow occurs while TCNT is counting up, the TCFV flag in TSR is set; when underflow occurs while TCNT is counting down, the TCFU flag is set. The TCFD bit in TSR is the count direction flag. Reading the TCFD flag provides an indication of whether TCNT is counting up or down. Table 9.19 shows the correspondence between external clock pins and channels.

**Table 9.19 Phase Counting Mode Clock Input Pins**

Channels	External Clock Pins	
	A-Phase	B-Phase
When channel 1 is set to phase counting mode	TCLKA	TCLKB
When channel 2 is set to phase counting mode	TCLKC	TCLKD

**Example of Phase Counting Mode Setting Procedure:** Figure 9.25 shows an example of the phase counting mode setting procedure.

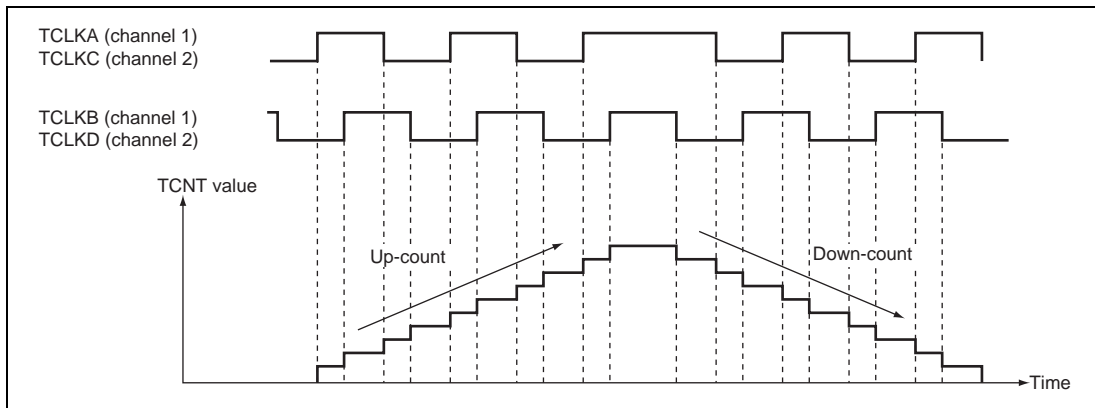


**Figure 9.25 Example of Phase Counting Mode Setting Procedure**

**Examples of Phase Counting Mode Operation:** In phase counting mode, TCNT counts up or down according to the phase difference between two external clocks. There are four modes, according to the count conditions.

### 1. Phase counting mode 1

Figure 9.26 shows an example of phase counting mode 1 operation, and table 9.20 summarizes the TCNT up/down-count conditions.



**Figure 9.26 Example of Phase Counting Mode 1 Operation**

**Table 9.20 Up/Down-Count Conditions in Phase Counting Mode 1**

TCLKA (Channel 1) TCLKC (Channel 2)	TCLKB (Channel 1) TCLKD (Channel 2)	Operation	
High level Low level	$\uparrow$ $\downarrow$	Up-count	
$\uparrow$ $\downarrow$	Low level High level		
High level Low level	$\downarrow$ $\uparrow$		Down-count
$\downarrow$ $\uparrow$	High level Low level		

Legend:

$\uparrow$  : Rising edge

$\downarrow$  : Falling edge

## 2. Phase counting mode 2

Figure 9.27 shows an example of phase counting mode 2 operation, and table 9.21 summarizes the TCNT up/down-count conditions.

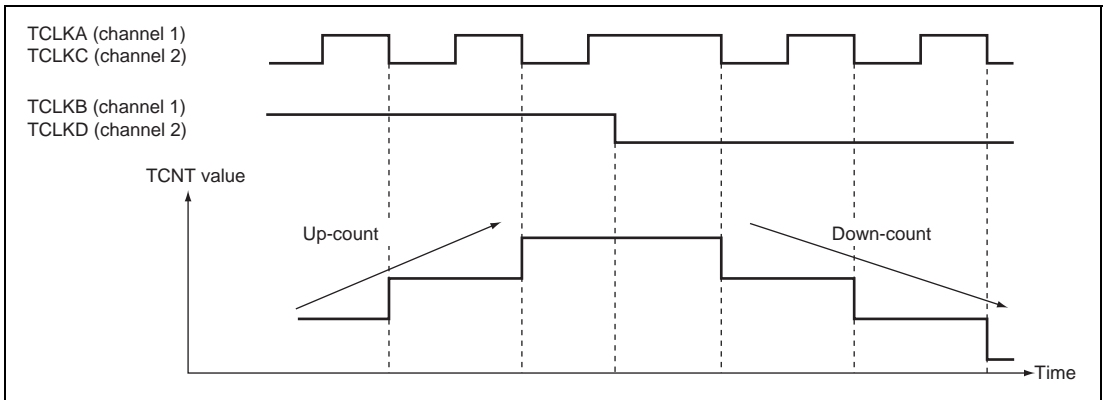


Figure 9.27 Example of Phase Counting Mode 2 Operation

Table 9.21 Up/Down-Count Conditions in Phase Counting Mode 2

TCLKA (Channel 1) TCLKC (Channel 2)	TCLKB (Channel 1) TCLKD (Channel 2)	Operation
High level	$\uparrow$	Don't care
Low level	$\downarrow$	Don't care
$\uparrow$	Low level	Don't care
$\downarrow$	High level	Up-count
High level	$\downarrow$	Don't care
Low level	$\uparrow$	Don't care
$\uparrow$	High level	Don't care
$\downarrow$	Low level	Down-count

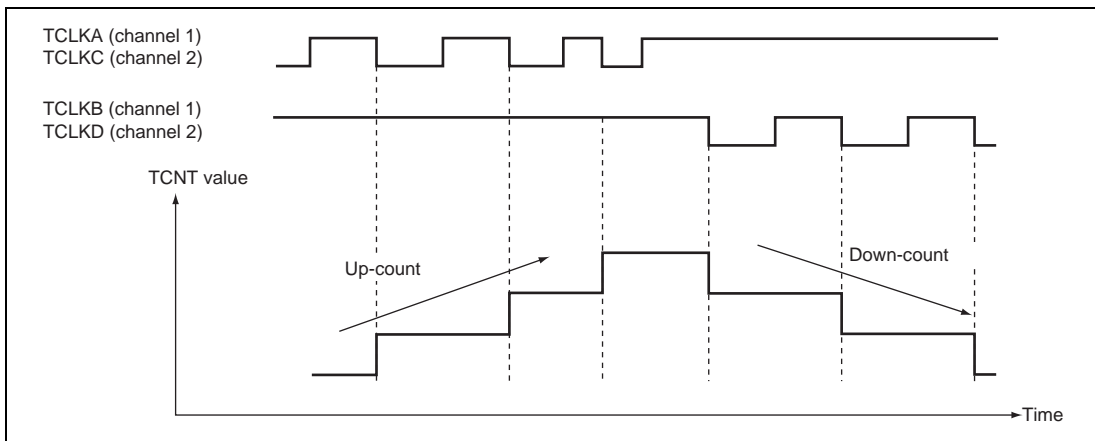
Legend:

$\uparrow$  : Rising edge

$\downarrow$  : Falling edge

## 3. Phase counting mode 3

Figure 9.28 shows an example of phase counting mode 3 operation, and table 9.22 summarizes the TCNT up/down-count conditions.



**Figure 9.28 Example of Phase Counting Mode 3 Operation**

**Table 9.22 Up/Down-Count Conditions in Phase Counting Mode 3**

TCLKA (Channel 1) TCLKC (Channel 2)	TCLKB (Channel 1) TCLKD (Channel 2)	Operation
High level	$\uparrow$	Don't care
Low level	$\downarrow$	Don't care
$\uparrow$	Low level	Don't care
$\downarrow$	High level	Up-count
High level	$\downarrow$	Down-count
Low level	$\uparrow$	Don't care
$\uparrow$	High level	Don't care
$\downarrow$	Low level	Don't care

Legend:

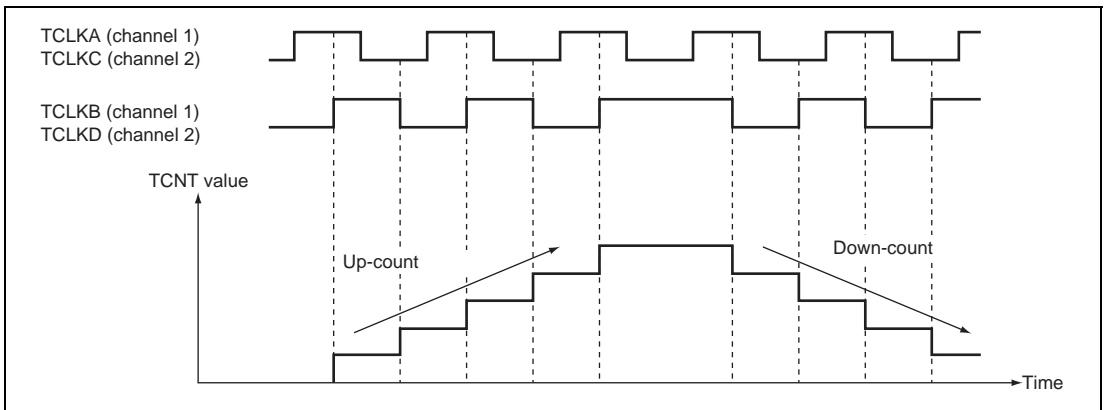
$\uparrow$  : Rising edge

$\downarrow$  : Falling edge



## 4. Phase counting mode 4

Figure 9.29 shows an example of phase counting mode 4 operation, and table 9.23 summarizes the TCNT up/down-count conditions.



**Figure 9.29 Example of Phase Counting Mode 4 Operation**

**Table 9.23 Up/Down-Count Conditions in Phase Counting Mode 4**

TCLKA (Channel 1) TCLKC (Channel 2)	TCLKB (Channel 1) TCLKD (Channel 2)	Operation
High level	$\uparrow$	Up-count
Low level	$\downarrow$	
$\uparrow$	Low level	Don't care
$\downarrow$	High level	
High level	$\downarrow$	Down-count
Low level	$\uparrow$	
$\uparrow$	High level	Don't care
$\downarrow$	Low level	

Legend:

$\uparrow$  : Rising edge

$\downarrow$  : Falling edge

## 9.6 Interrupts

### 9.6.1 Interrupt Source and Priority

There are three kinds of TPU interrupt source: TGR input capture/compare match, TCNT overflow, and TCNT underflow. Each interrupt source has its own status flag and enable/disable bit, allowing generation of interrupt request signals to be enabled or disabled individually. When an interrupt request is generated, the corresponding status flag in TSR is set to 1. If the corresponding enable/disable bit in TIER is set to 1 at this time, an interrupt is requested. The interrupt request is cleared by clearing the status flag to 0. Relative channel priorities can be changed by the interrupt controller, but the priority order within a channel is fixed. For details, see section 5, Interrupt Controller. Table 9.24 lists the TPU interrupt sources.

**Table 9.24 TPU Interrupts**

Channel	Name	Interrupt Source	Interrupt Flag	DMAC Activation	Priority*
0	TGI0A	TGRA_0 input capture/compare match	TGFA	Possible	High ↑
	TGI0B	TGRB_0 input capture/compare match	TGFB	Not possible	
	TGI0C	TGRC_0 input capture/compare match	TGFC	Not possible	
	TGI0D	TGRD_0 input capture/compare match	TGFD	Not possible	
	TCI0V	TCNT_0 overflow	TCFV	Not possible	
1	TGI1A	TGRA_1 input capture/compare match	TGFA	Possible	↑
	TGI1B	TGRB_1 input capture/compare match	TGFB	Not possible	
	TCI1V	TCNT_1 overflow	TCFV	Not possible	
	TCI1U	TCNT_1 underflow	TCFU	Not possible	
2	TGI2A	TGRA_2 input capture/compare match	TGFA	Possible	↑
	TGI2B	TGRB_2 input capture/compare match	TGFB	Not possible	
	TCI2V	TCNT_2 overflow	TCFV	Not possible	
	TCI2U	TCNT_2 underflow	TCFU	Not possible	

Note: \* This table shows the initial state immediately after a reset. The relative channel priorities can be changed by the interrupt controller.

**Input Capture/Compare Match Interrupt:** An interrupt is requested if the TGIE bit in TIER is set to 1 when the TGF flag in TSR is set to 1 by the occurrence of a TGR input capture/compare match on a particular channel. The interrupt request is cleared by clearing the TGF flag to 0. The TPU has 8 input capture/compare match interrupts, four each for channel 0, and two each for channels 1 and 2.

**Overflow Interrupt:** An interrupt is requested if the TCIEV bit in TIER is set to 1 when the TCFV flag in TSR is set to 1 by the occurrence of TCNT overflow on a channel. The interrupt request is cleared by clearing the TCFV flag to 0. The TPU has three overflow interrupts, one for each channel.

**Underflow Interrupt:** An interrupt is requested if the TCIEU bit in TIER is set to 1 when the TCFU flag in TSR is set to 1 by the occurrence of TCNT underflow on a channel. The interrupt request is cleared by clearing the TCFU flag to 0. The TPU has two underflow interrupts, one each for channels 1 and 2.

### 9.6.2 DMAC Activation

The DMAC can be activated by the TGRA input capture/compare match interrupt for a channel. For details, see section 7, DMA Controller (DMAC). With the TPU, a total of three TGRA input capture/compare match interrupts can be used as DMAC activation sources, one for each channel.

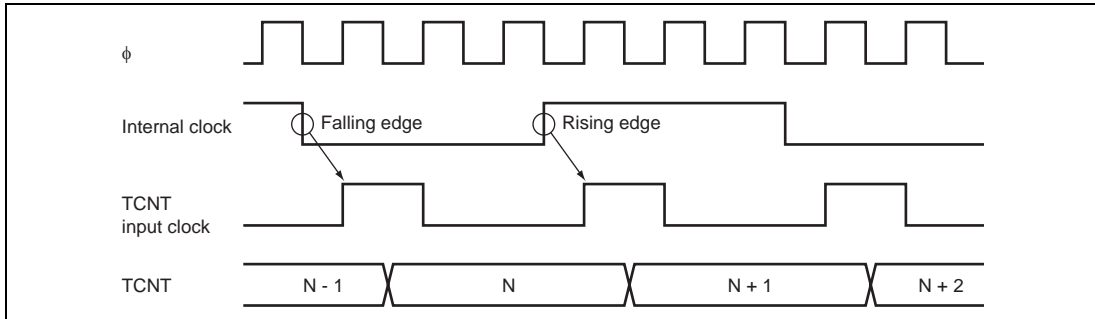
### 9.6.3 A/D Converter Activation

The A/D converter can be activated by the TGRA input capture/compare match for a channel. If the TTGE bit in TIER is set to 1 when the TGFA flag in TSR is set to 1 by the occurrence of a TGRA input capture/compare match on a particular channel, a request to start A/D conversion is sent to the A/D converter. If the TPU conversion start trigger has been selected on the A/D converter side at this time, A/D conversion is started. In the TPU, a total of three TGRA input capture/compare match interrupts can be used as A/D converter conversion start sources, one for each channel.

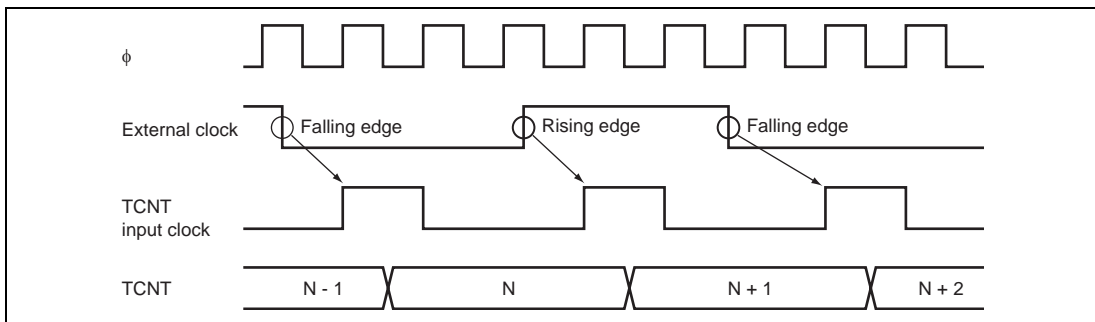
## 9.7 Operation Timing

### 9.7.1 Input/Output Timing

**TCNT Count Timing:** Figure 9.30 shows TCNT count timing in internal clock operation, and figure 9.31 shows TCNT count timing in external clock operation.

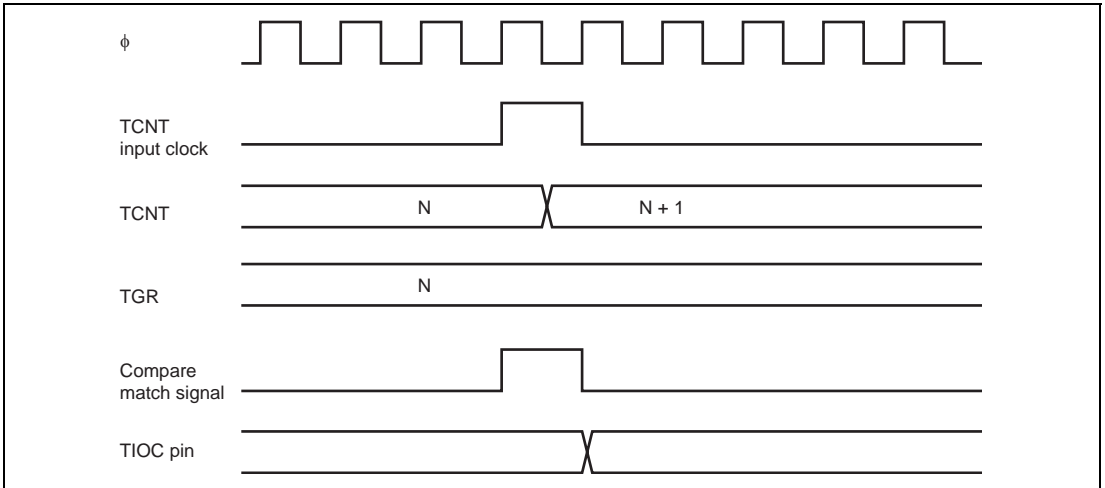


**Figure 9.30 Count Timing in Internal Clock Operation**



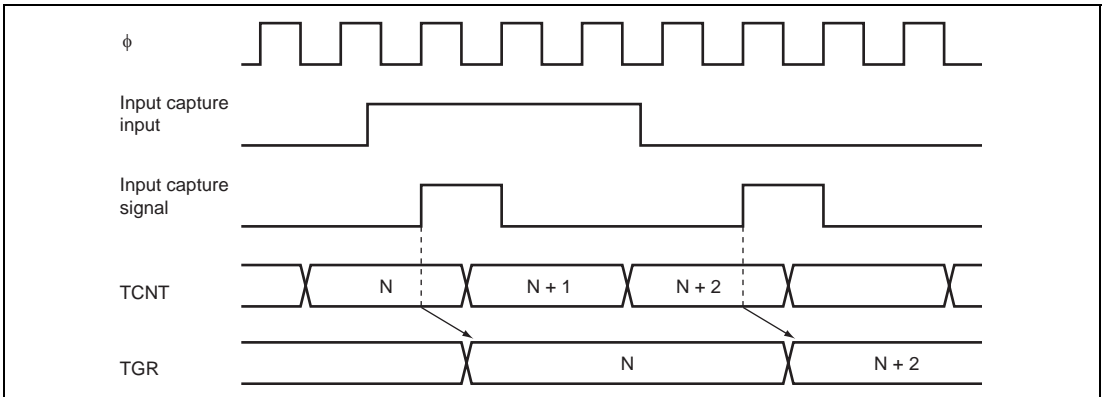
**Figure 9.31 Count Timing in External Clock Operation**

**Output Compare Output Timing:** A compare match signal is generated in the final state in which TCNT and TGR match (the point at which the count value matched by TCNT is updated). When a compare match signal is generated, the output value set in TIOR is output at the output compare output pin. After a match between TCNT and TGR, the compare match signal is not generated until the TCNT input clock is generated. Figure 9.32 shows output compare output timing.



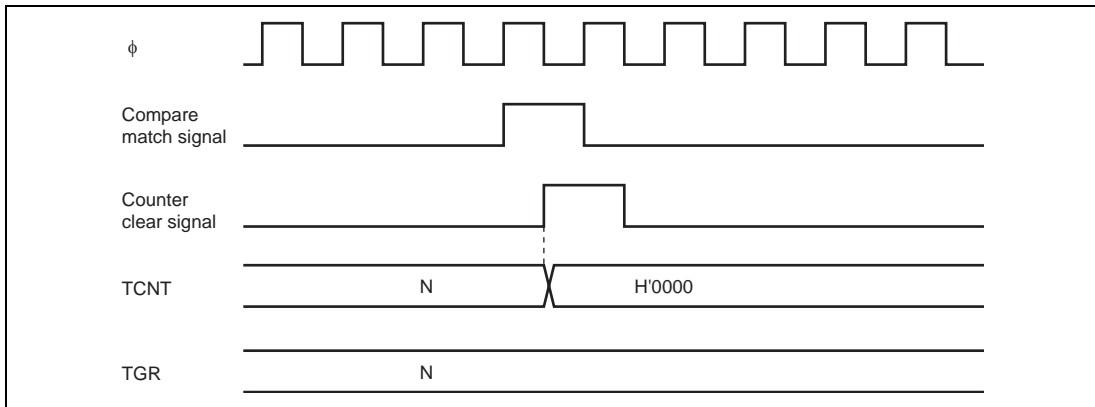
**Figure 9.32 Output Compare Output Timing**

**Input Capture Signal Timing:** Figure 9.33 shows input capture signal timing.

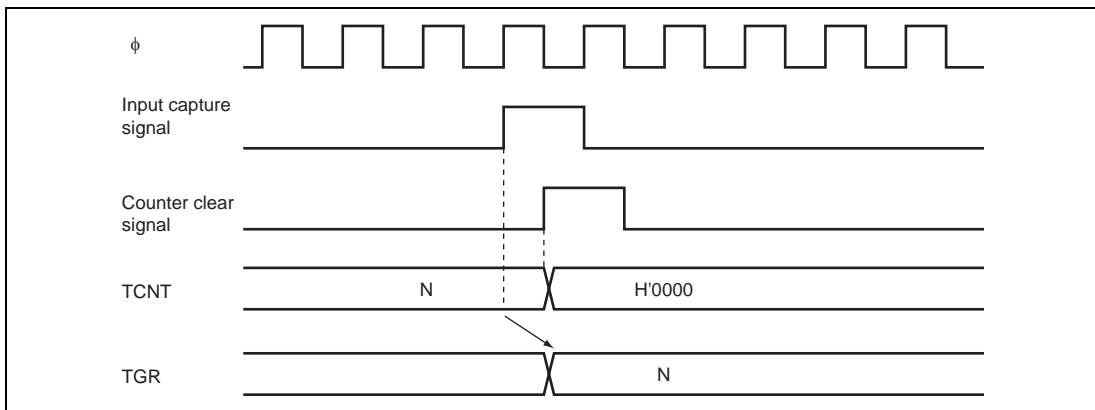


**Figure 9.33 Input Capture Input Signal Timing**

**Timing for Counter Clearing by Compare Match/Input Capture:** Figure 9.34 shows the timing when counter clearing by compare match occurrence is specified, and figure 9.35 shows the timing when counter clearing by input capture occurrence is specified.

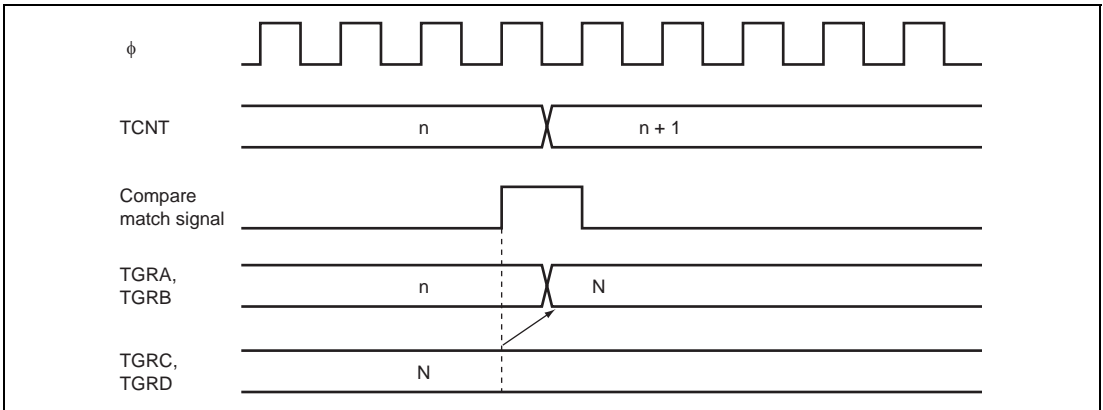


**Figure 9.34 Counter Clear Timing (Compare Match)**

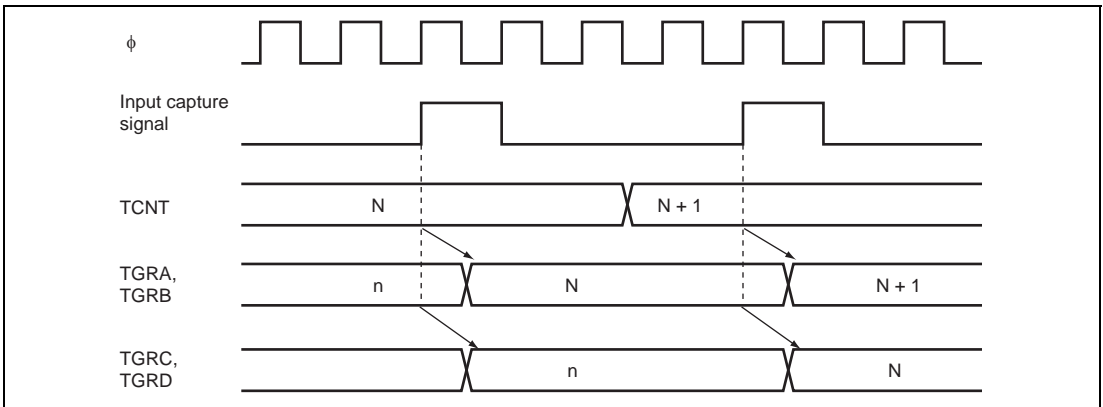


**Figure 9.35 Counter Clear Timing (Input Capture)**

**Buffer Operation Timing:** Figures 9.36 and 9.37 show the timing in buffer operation.



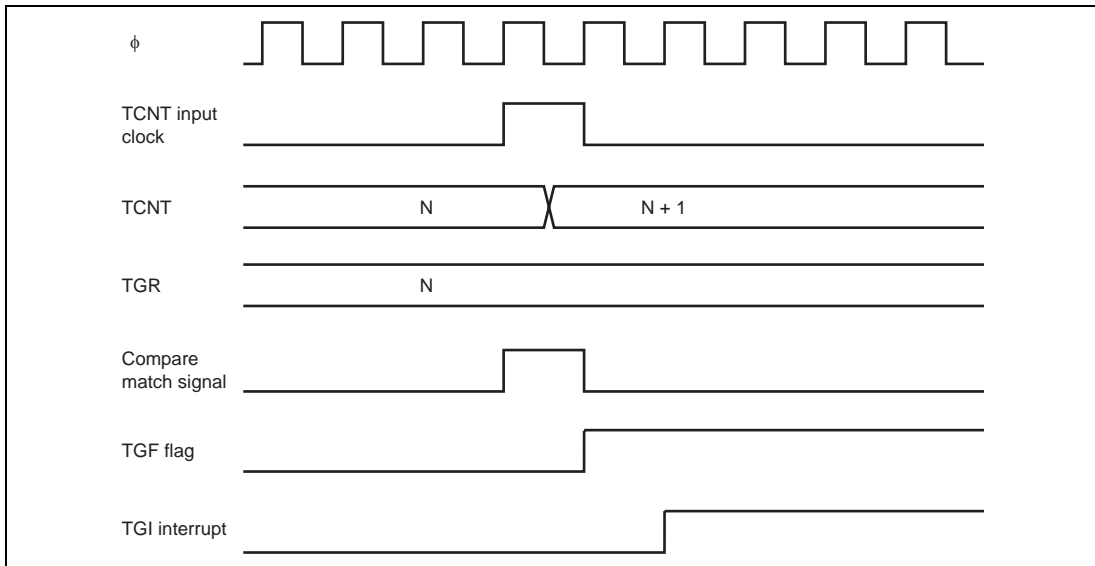
**Figure 9.36 Buffer Operation Timing (Compare Match)**



**Figure 9.37 Buffer Operation Timing (Input Capture)**

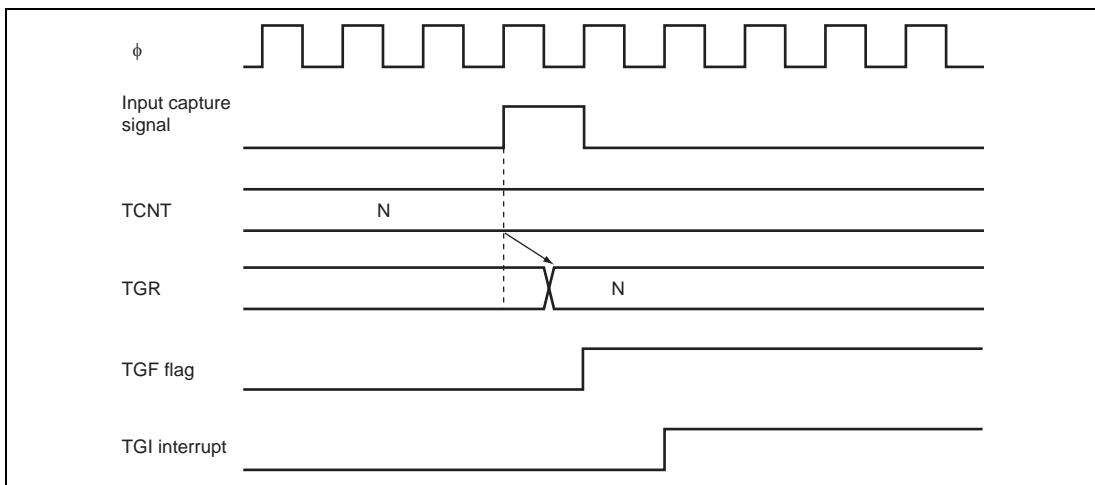
## 9.7.2 Interrupt Signal Timing

**TGF Flag Setting Timing in Case of Compare Match:** Figure 9.38 shows the timing for setting of the TGF flag in TSR by compare match occurrence, and TGI interrupt request signal timing.



**Figure 9.38 TGI Interrupt Timing (Compare Match)**

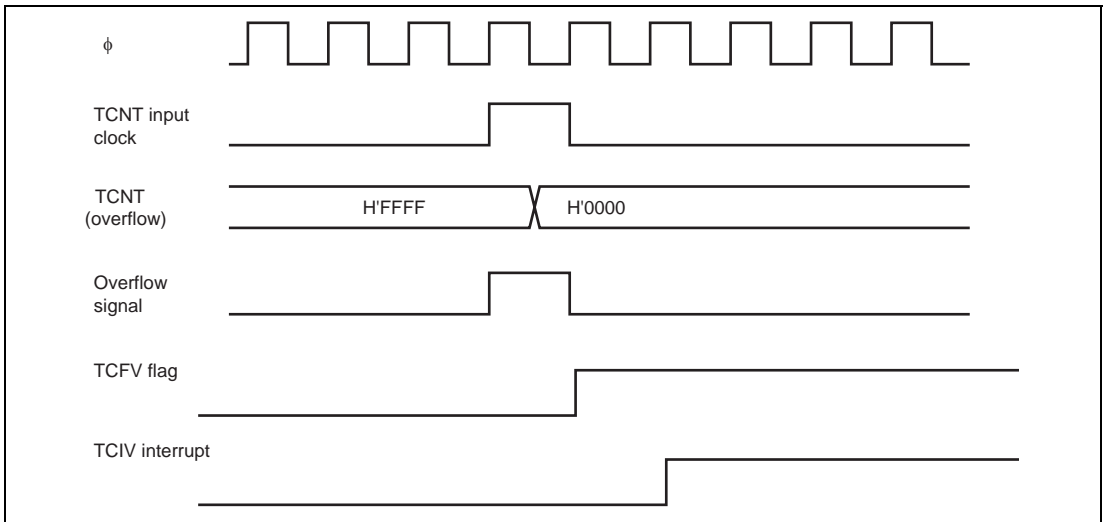
**TGF Flag Setting Timing in Case of Input Capture:** Figure 9.39 shows the timing for setting of the TGF flag in TSR by input capture occurrence, and TGI interrupt request signal timing.



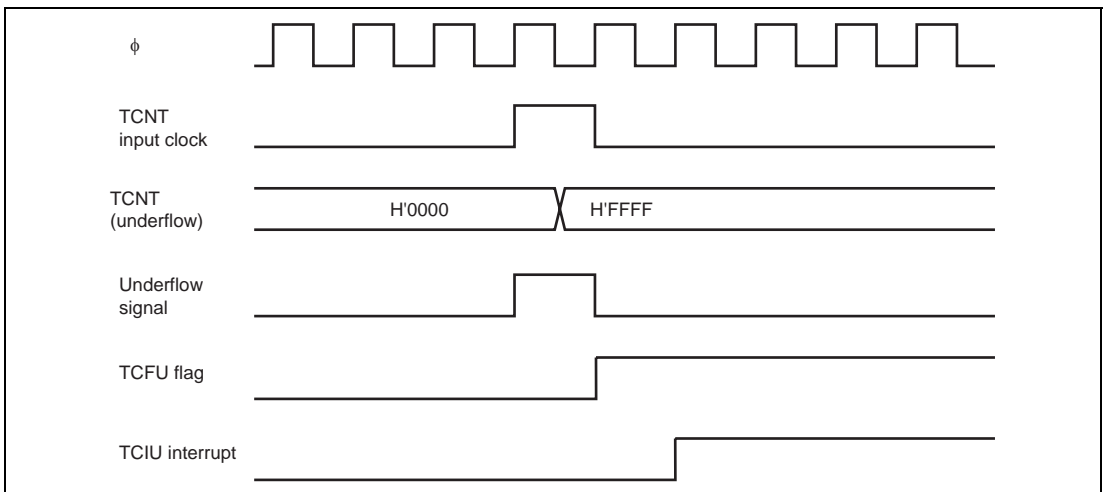
**Figure 9.39 TGI Interrupt Timing (Input Capture)**



**TCFV Flag/TCFU Flag Setting Timing:** Figure 9.40 shows the timing for setting of the TCFV flag in TSR by overflow occurrence, and TCIV interrupt request signal timing. Figure 9.41 shows the timing for setting of the TCFU flag in TSR by underflow occurrence, and TCIU interrupt request signal timing.

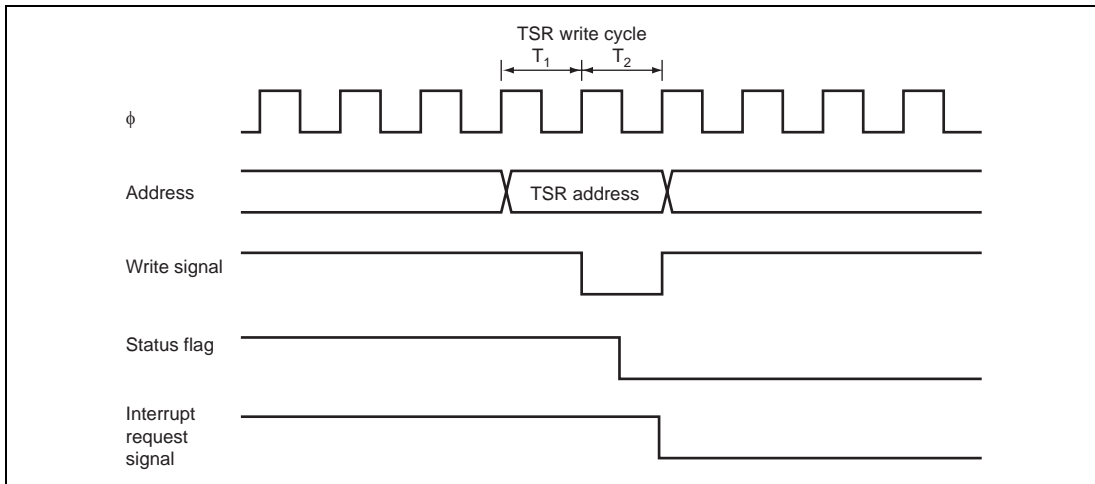


**Figure 9.40 TCIV Interrupt Setting Timing**

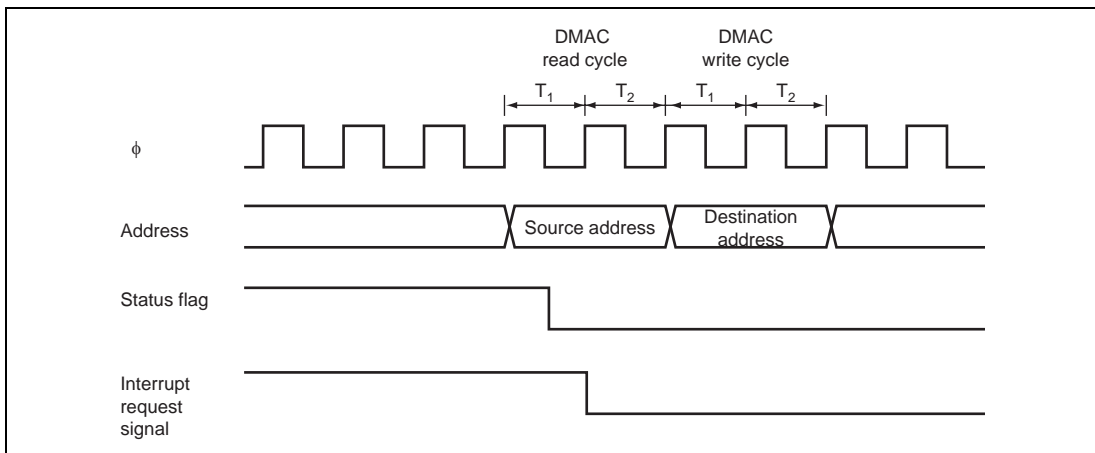


**Figure 9.41 TCIU Interrupt Setting Timing**

**Status Flag Clearing Timing:** After a status flag is read as 1 by the CPU, it is cleared by writing 0 to it. When the DMAC is activated, the flag is cleared automatically. Figure 9.42 shows the timing for status flag clearing by the CPU, and figure 9.43 shows the timing for status flag clearing by the DMAC.



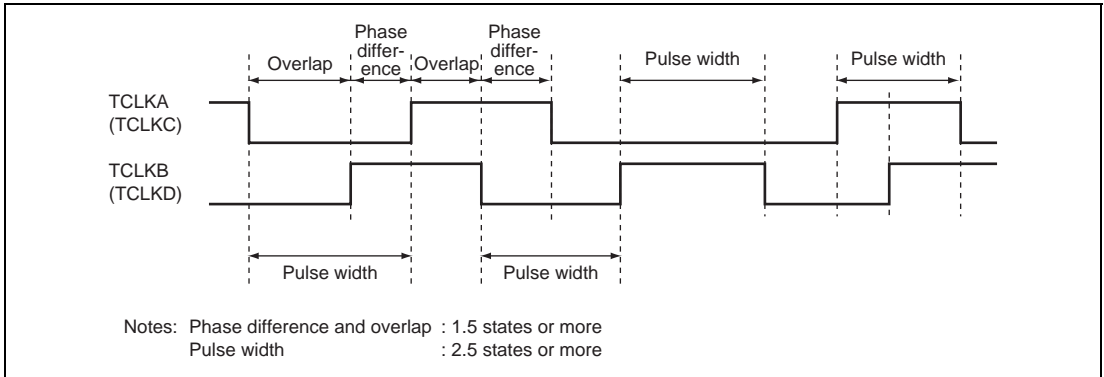
**Figure 9.42 Timing for Status Flag Clearing by CPU**



**Figure 9.43 Timing for Status Flag Clearing by DMAC Activation**

## 9.8 Usage Notes

**Input Clock Restrictions:** The input clock pulse width must be at least 1.5 states in the case of single-edge detection, and at least 2.5 states in the case of both-edge detection. The TPU will not operate properly with a narrower pulse width. In phase counting mode, the phase difference and overlap between the two input clocks must be at least 1.5 states, and the pulse width must be at least 2.5 states. Figure 9.44 shows the input clock conditions in phase counting mode.



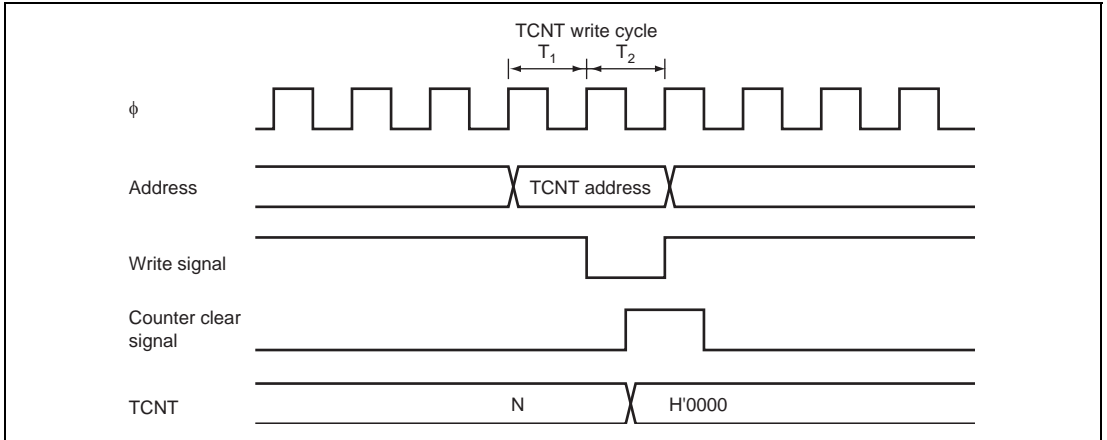
**Figure 9.44 Phase Difference, Overlap, and Pulse Width in Phase Counting Mode**

**Caution on Period Setting:** When counter clearing by compare match is set, TCNT is cleared in the final state in which it matches the TGR value (the point at which the count value matched by TCNT is updated). Consequently, the actual counter frequency is given by the following formula:

$$f = \frac{\phi}{(N + 1)}$$

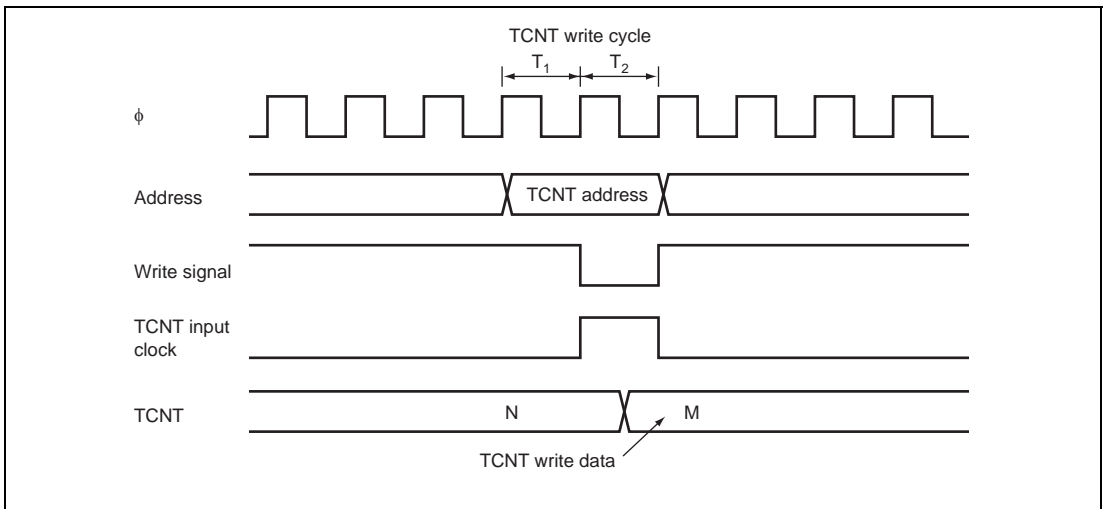
Where f : Counter frequency  
 $\phi$  : Operating frequency  
 N : TGR set value

**Contention between TCNT Write and Clear Operations:** If the counter clear signal is generated in the  $T_2$  state of a TCNT write cycle, TCNT clearing takes precedence and the TCNT write is not performed. Figure 9.45 shows the timing in this case.



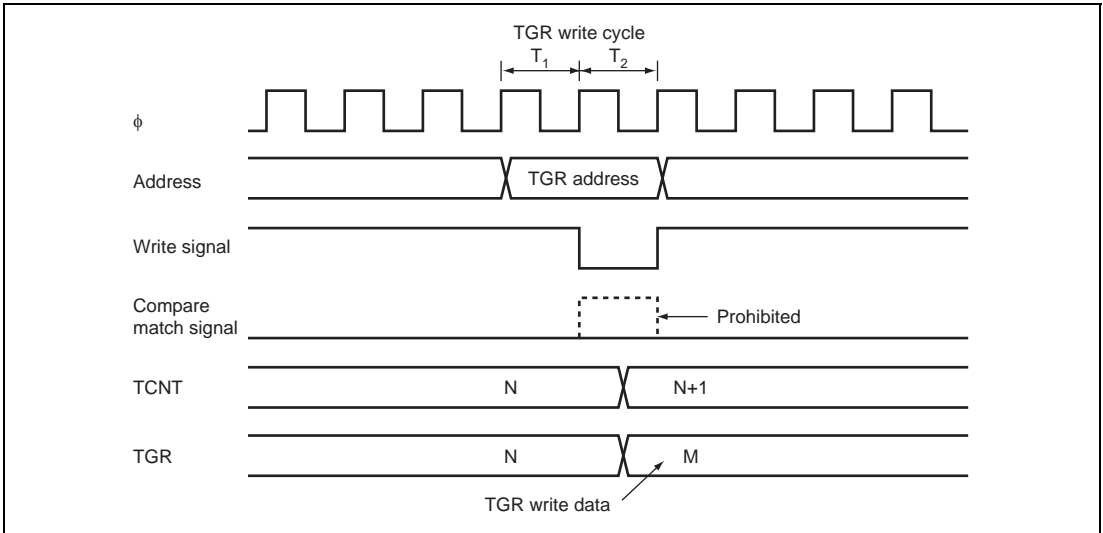
**Figure 9.45 Contention between TCNT Write and Clear Operations**

**Contention between TCNT Write and Increment Operations:** If incrementing occurs in the  $T_2$  state of a TCNT write cycle, the TCNT write takes precedence and TCNT is not incremented. Figure 9.46 shows the timing in this case.



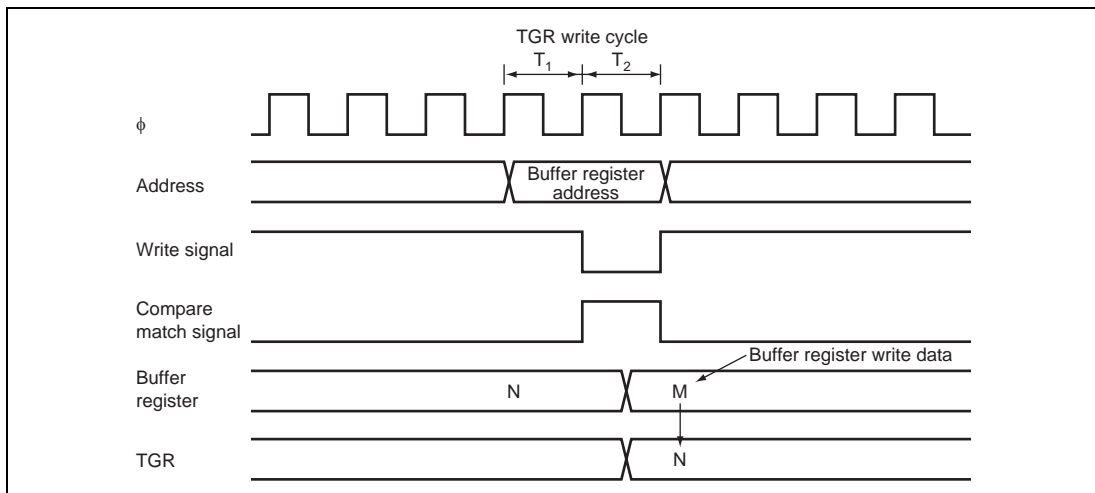
**Figure 9.46 Contention between TCNT Write and Increment Operations**

**Contention between TGR Write and Compare Match:** If a compare match occurs in the  $T_2$  state of a TGR write cycle, the TGR write takes precedence and the compare match signal is inhibited. A compare match does not occur even if the same value as before is written. Figure 9.47 shows the timing in this case.



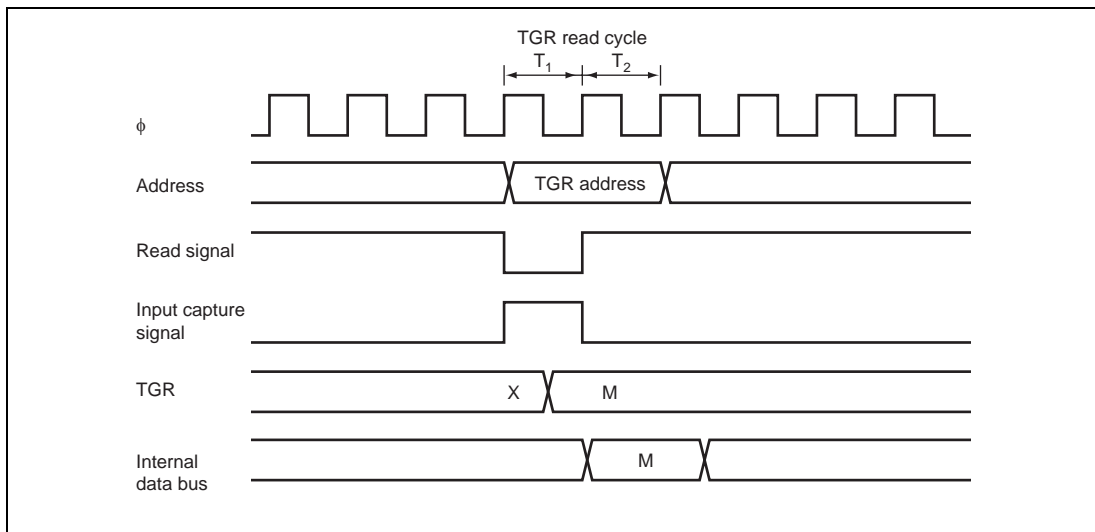
**Figure 9.47 Contention between TGR Write and Compare Match**

**Contention between Buffer Register Write and Compare Match:** If a compare match occurs in the  $T_2$  state of a TGR write cycle, the data transferred to TGR by the buffer operation will be the data prior to the write. Figure 9.48 shows the timing in this case.



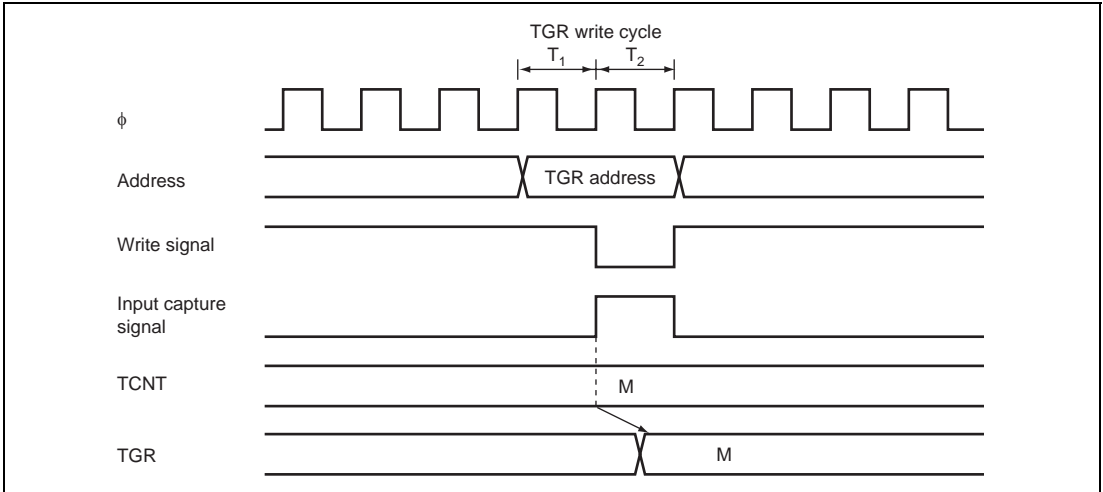
**Figure 9.48 Contention between Buffer Register Write and Compare Match**

**Contention between TGR Read and Input Capture:** If the input capture signal is generated in the  $T_1$  state of a TGR read cycle, the data that is read will be the data after input capture transfer. Figure 9.49 shows the timing in this case.



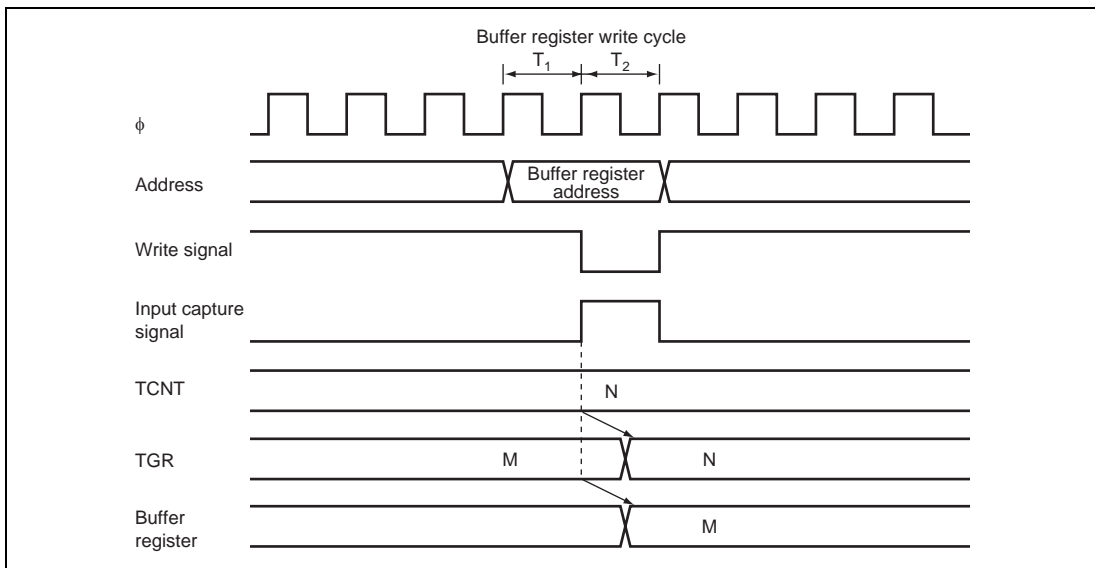
**Figure 9.49 Contention between TGR Read and Input Capture**

**Contention between TGR Write and Input Capture:** If the input capture signal is generated in the  $T_2$  state of a TGR write cycle, the input capture operation takes precedence and the write to TGR is not performed. Figure 9.50 shows the timing in this case.



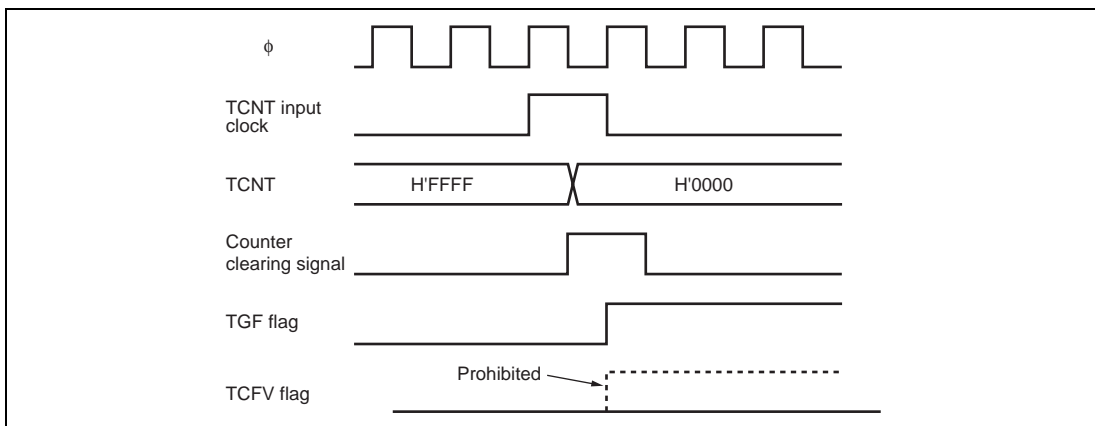
**Figure 9.50 Contention between TGR Write and Input Capture**

**Contention between Buffer Register Write and Input Capture:** If the input capture signal is generated in the  $T_2$  state of a buffer register write cycle, the buffer operation takes precedence and the write to the buffer register is not performed. Figure 9.51 shows the timing in this case.



**Figure 9.51 Contention between Buffer Register Write and Input Capture**

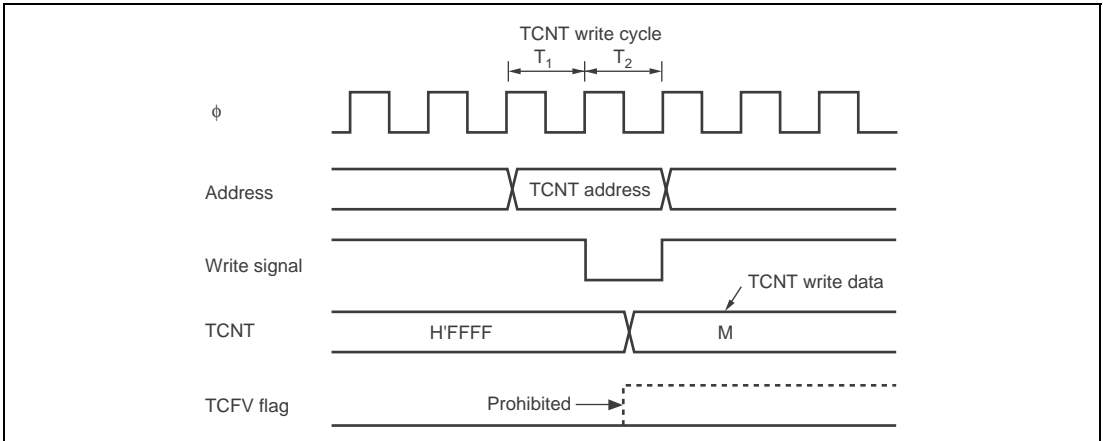
**Contention between Overflow/Underflow and Counter Clearing:** If overflow/underflow and counter clearing occur simultaneously, the TCFV/TCFU flag in TSR is not set and TCNT clearing takes precedence. Figure 9.52 shows the operation timing when a TGR compare match is specified as the clearing source, and H'FFFF is set in TGR.



**Figure 9.52 Contention between Overflow and Counter Clearing**



**Contention between TCNT Write and Overflow/Underflow:** If there is an up-count or down-count in the  $T_2$  state of a TCNT write cycle, and overflow/underflow occurs, the TCNT write takes precedence and the TCFV/TCFU flag in TSR is not set. Figure 9.53 shows the operation timing when there is contention between TCNT write and overflow.



**Figure 9.53 Contention between TCNT Write and Overflow**

**Multiplexing of I/O Pins:** In this LSI, the TCLKA input pin is multiplexed with the TIOCC0 I/O pin, the TCLKB input pin with the TIOCD0 I/O pin, the TCLKC input pin with the TIOCB1 I/O pin, and the TCLKD input pin with the TIOCB2 I/O pin. When an external clock is input, compare match output should not be performed from a multiplexed pin.

**Interrupts in Module Stop Mode:** If module stop mode is entered when an interrupt has been requested, it will not be possible to clear the CPU interrupt source or the DMAC activation source. Interrupts should therefore be disabled before entering module stop mode.

**Module Stop Mode Setting:** TPU operation can be disabled or enabled using the module stop control register. The initial setting is for TPU operation to be halted. Register access is enabled by clearing module stop mode. For details, refer to section 20, Power-Down Modes.



## Section 10 Watchdog Timer (WDT)

The watchdog timer (WDT) is an 8-bit timer that can generate an internal reset signal for this LSI if a system crash prevents the CPU from writing to the timer counter, thus allowing it to overflow. When this watchdog function is not needed, the WDT can be used as an interval timer. In interval timer operation, an interval timer interrupt is generated each time the counter overflows.

The block diagram of the WDT is shown in figure 10.1.

### 10.1 Features

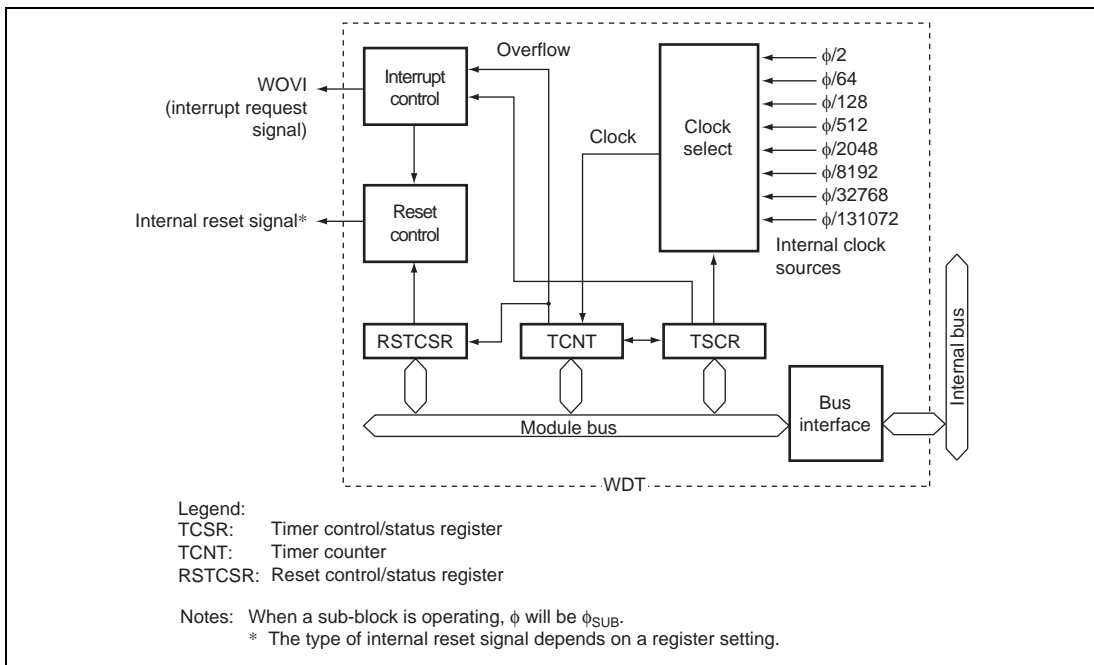
- Selectable from eight counter input clocks
- Switchable between watchdog timer mode and interval timer mode

In watchdog timer mode:

- If the counter overflows, it is possible to select whether this LSI is internally reset or not.

In interval timer mode:

- If the counter overflows, the WDT generates an interval timer interrupt (WOVI).



**Figure 10.1 Block Diagram of WDT**

## 10.2 Register Descriptions

The WDT has the following three registers. For details, refer to section 21, List of Registers. To prevent accidental overwriting, TCSR, TCNT, and RSTCSR have to be written to by a different method to normal registers. For details, refer to section 10.5.1, Notes on Register Access.

- Timer counter (TCNT)
- Timer control/status register (TCSR)
- Reset control/status register (RSTCSR)

### 10.2.1 Timer Counter (TCNT)

TCNT is an 8-bit readable/writable up-counter. TCNT is initialized to H'00 by a reset, when the TME bit in TCSR is cleared to 0.

### 10.2.2 Timer Control/Status Register (TCSR)

TCSR is an 8-bit readable/writable register. Its functions include selecting the clock source to be input to TCNT, and selecting the timer mode.

Bit	Bit Name	Initial Value	R/W	Description
7	OVF	0	R/(W)*	<p>Overflow Flag</p> <p>Indicates that TCNT has overflowed. Only a write of 0 is permitted, to clear the flag.</p> <p>[Setting condition]</p> <p>When TCNT overflows (changes from H'FF to H'00)</p> <p>When internal reset request generation is selected in watchdog timer mode, OVF is cleared automatically by the internal reset.</p> <p>[Clearing condition]</p> <p>Cleared by reading TCSR when OVF = 1, then writing 0 to OVF</p> <p>When polling CVF when the interval timer interrupt has been prohibited, OVF = 1 status should be read two or more times.</p>
6	WT/IT	0	R/W	<p>Timer Mode Select</p> <p>Selects whether the WDT is used as a watchdog timer or interval timer.</p> <p>0: Interval timer mode</p> <p>1: Watchdog timer mode</p>
5	TME	0	R/W	<p>Timer Enable</p> <p>When this bit is set to 1, TCNT starts counting.</p> <p>When this bit is cleared, TCNT stops counting and is initialized to H'00.</p>
4, 3	—	All 1	—	<p>Reserved</p> <p>These bits are always read as 1 and cannot be modified.</p>
2	CKS2	0	R/W	Clock Select 0 to 2
1	CKS1	0	R/W	Selects the clock source to be input to TCNT. The overflow frequency for $\phi = 16$ MHz is enclosed in parentheses. The overflow period is the time from when TCNT starts counting up from H'00 until overflow occurs.
0	CKS0	0	R/W	<p>000: Clock <math>\phi/2</math> (frequency: 32.0 <math>\mu</math>s)</p> <p>001: Clock <math>\phi/64</math> (frequency: 1.0 ms)</p> <p>010: Clock <math>\phi/128</math> (frequency: 2.0 ms)</p> <p>011: Clock <math>\phi/512</math> (frequency: 8.2 ms)</p> <p>100: Clock <math>\phi/2048</math> (frequency: 32.8 ms)</p> <p>101: Clock <math>\phi/8192</math> (frequency: 131.1 ms)</p> <p>110: Clock <math>\phi/32768</math> (frequency: 524.3 ms)</p> <p>111: Clock <math>\phi/131072</math> (frequency: 2.1 s)</p>

Note: \* The write value should always be 0 to clear this flag.

### 10.2.3 Reset Control/Status Register (RSTCSR)

RSTCSR is an 8-bit readable/writable register that controls the generation of the internal reset signal when TCNT overflows, and selects the type of internal reset signal. RSTCSR is initialized to H'1F by a reset signal from the  $\overline{\text{RES}}$  pin, and not by the WDT internal reset signal caused by overflows.

Bit	Bit Name	Initial Value	R/W	Description
7	WOVF	0	R/(W)* <sup>1</sup>	<p>Watchdog Overflow Flag</p> <p>This bit is set when TCNT overflows in watchdog timer mode. This bit cannot be set in interval timer mode, and the write value should always be 0.</p> <p>[Setting condition] Set when TCNT overflows (changed from H'FF to H'00) in watchdog timer mode</p> <p>[Clearing condition] Cleared by reading RSTCSR when WOVF = 1, and then writing 0 to WOVF</p>
6	RSTE	0	R/W	<p>Reset Enable</p> <p>Specifies whether or not a reset signal is generated in the chip if TCNT overflows during watchdog timer operation.</p> <p>0: Reset signal is not generated even if TCNT overflows (Though this LSI is not reset, TCNT and TCSR in WDT are reset)</p> <p>1: Reset signal is generated if TCNT overflows</p>
5	RSTS	0	R/W	<p>Reset Select</p> <p>Selects the type of internal reset generated if TCNT overflows during watchdog timer operation.</p> <p>0: Power-on reset*<sup>2</sup> 1: Manual reset*<sup>3</sup></p>
4 to 0	—	All 1	—	<p>Reserved</p> <p>These bits are always read as 1 and cannot be modified.</p>

- Notes:
1. The write value should always be 0 to clear this flag.
  2. Bear in mind that the USB register is not initialized by a power-on reset triggered by the WDT. For details, see section 14.8.8, Reset.
  3. Supported only by the H8S/2218 Group.

## 10.3 Operation

### 10.3.1 Watchdog Timer Mode

To use the WDT as a watchdog timer, set the  $\overline{WT/IT}$  bit in TCSR and the TME bit to 1.

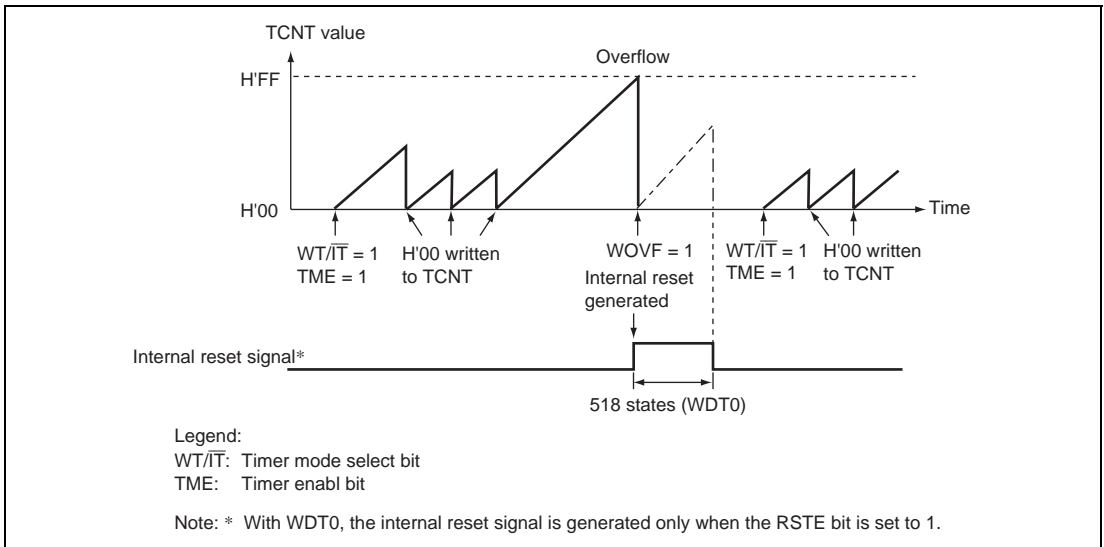
TCNT does not overflow while the system is operating normally. Software must prevent TCNT overflows by rewriting the TCNT value (normally be writing H'00) before overflows occurs.

When the RSTE bit of the RSTCSR is set to 1, and if the TCNT overflows, an internal reset signal for this LSI is issued. In this case, select power-on reset or manual reset\* by setting the RSTS bit of the RSTCSR to 0.

If a reset caused by a signal input to the  $\overline{RES}$  pin occurs at the same time as a reset caused by a WDT overflow, the  $\overline{RES}$  pin reset has priority and the WOVF bit in RSTCSR is cleared to 0. The internal reset signal is output for 518 states.

When the TCNT overflows in watchdog timer mode, the WOVF bit of the RSTCSR is set to 1. If the RSTE bit of the RSTCSR has been set to 1, an internal reset signal for the entire LSI is generated at TCNT overflow.

Note: \* Supported only by the H8S/2218 Group.



**Figure 10.2 Operation in Watchdog Timer Mode**

### 10.3.2 Timing of Setting of Watchdog Timer Overflow Flag (WOVF)

With WDT, the WOVM bit in RSTCSR is set to 1 if TCNT overflows in watchdog timer mode. If TCNT overflows while the RSTE bit in RSTCSR is set to 1, an internal reset signal is generated for the entire chip. This timing is illustrated in figure 10.3.

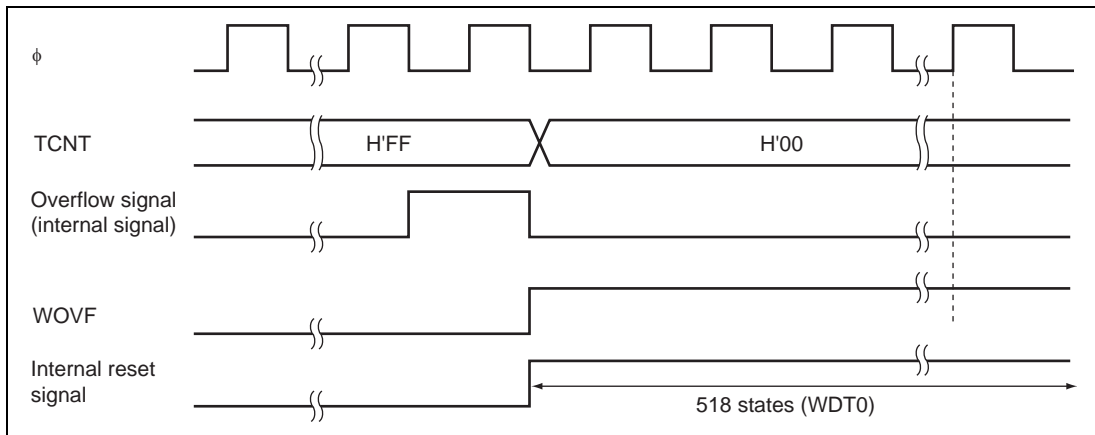


Figure 10.3 Timing of WOVM Setting

### 10.3.3 Interval Timer Mode

To use the WDT as an interval timer, clear bit  $WT/\overline{IT}$  in TCSR to 0 and set bit TME to 1. When the interval timer is operating, an interval timer interrupt (WOVI) is generated each time the TCNT overflows. Therefore, an interrupt can be generated at intervals.

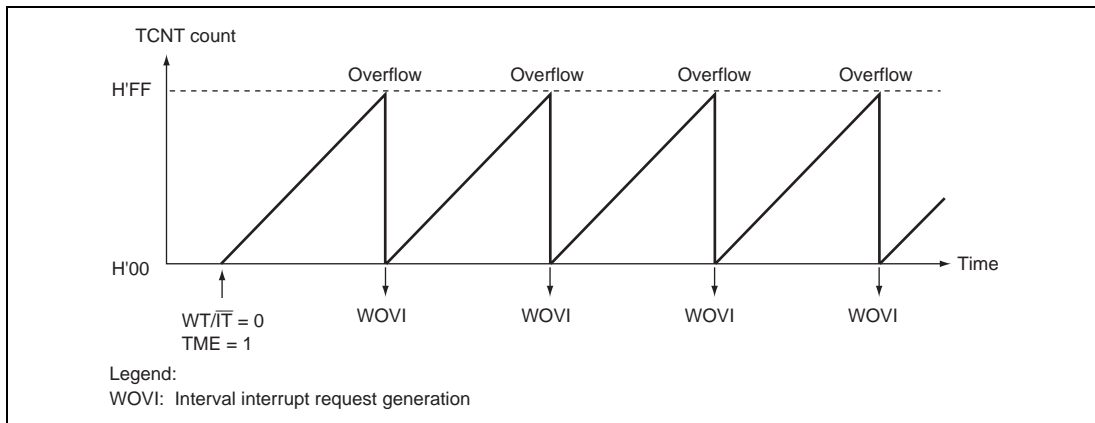
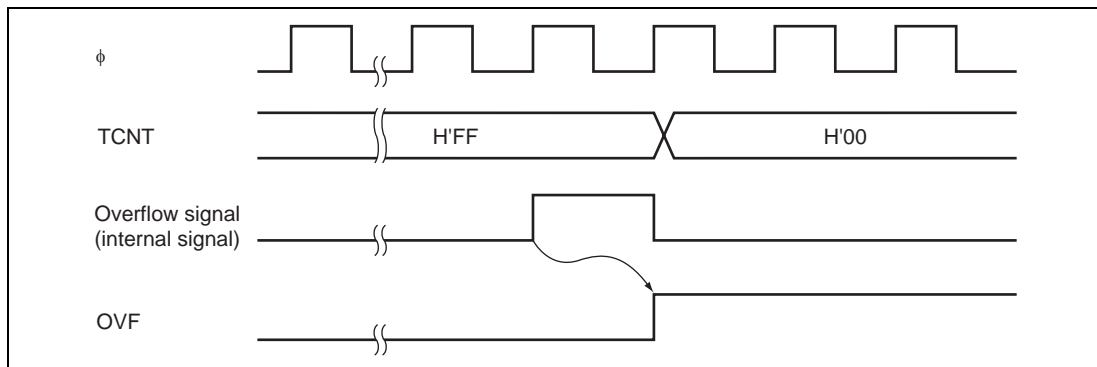


Figure 10.4 Operation in Interval Timer Mode



### 10.3.4 Timing of Setting of Overflow Flag (OVF)

The OVF flag is set to 1 if TCNT overflows during interval timer operation. At the same time, an interval timer interrupt (WOVI) is requested. This timing is shown in figure 10.5.



**Figure 10.5 Timing of OVF Setting**

## 10.4 Interrupts

During interval timer mode operation, an overflow generates an interval timer interrupt (WOVI). The interval timer interrupt is requested whenever the OVF flag is set to 1 in TCSR. OVF must be cleared to 0 in the interrupt handling routine.

**Table 10.1 WDT Interrupt Source**

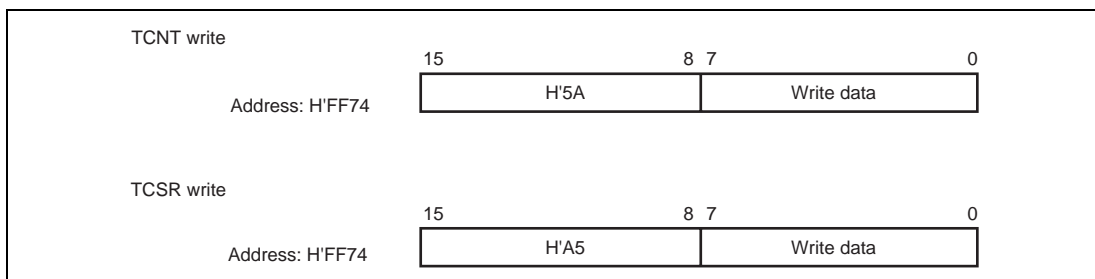
Name	Interrupt Source	Interrupt Flag
WOVI	TCNT overflow	WOVF

## 10.5 Usage Notes

### 10.5.1 Notes on Register Access

The watchdog timer's TCNT, TCSR, and RSTCSR registers differ from other registers in being more difficult to write to. The procedures for writing to and reading these registers are given below.

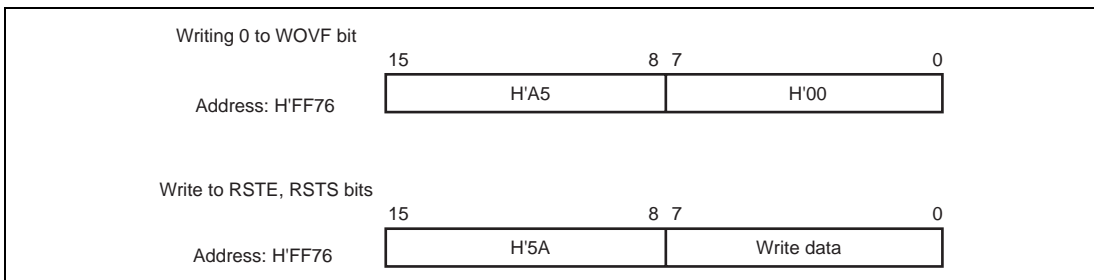
**Writing to TCNT and TCSR:** These registers must be written to by a word transfer instruction. They cannot be written to with byte transfer instructions. Figure 10.6 shows the format of data written to TCNT and TCSR. TCNT and TCSR both have the same write address. For a write to TCNT, the upper byte of the written word must contain H'5A and the lower byte must contain the write data. For a write to TCSR, the upper byte of the written word must contain H'A5 and the lower byte must contain the write data. This transfers the write data from the lower byte to TCNT or TCSR.



**Figure 10.6 Format of Data Written to TCNT and TCSR**

**Writing to RSTCSR:** RSTCSR must be written to by a word transfer to address H'FF76. It cannot be written to with byte instructions. Figure 10.7 shows the format of data written to RSTCSR. The method of writing 0 to the WOVF bit differs from that for writing to the RSTE and RSTS bits.

To write 0 to the WOVF bit, the upper byte of the written word must contain H'A5 and the lower byte must contain H'00. This clears the WOVF bit to 0, but has no effect on the RSTE and RSTS bits. To write to the RSTE and RSTS bits, the upper byte must contain H'5A and the lower byte must contain the write data. This writes the values in bits 6 and 5 of the lower byte into the RSTE and RSTS bits, but has no effect on the WOVF bit.

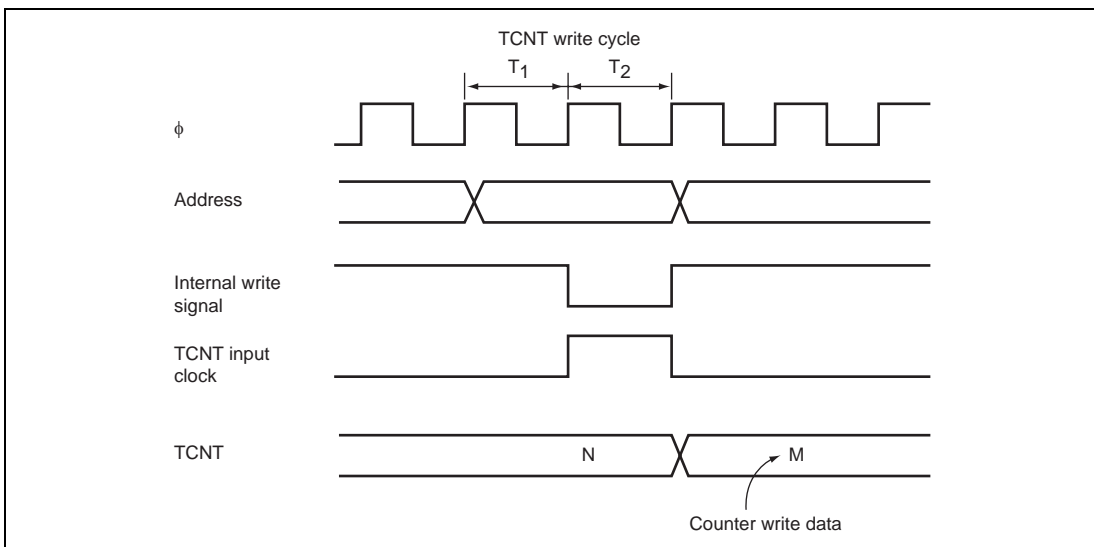


**Figure 10.7 Format of Data Written to RSTCSR (Example of WDT0)**

**Reading from TCNT, TCSR, and RSTCSR:** TCNT, TCSR, and RSTCSR are read by using the same method as for the general registers. TCSR, TCNT, and RSTCSR are allocated in addresses H'FF74, H'FF75, and H'FF77 respectively.

### 10.5.2 Contention between Timer Counter (TCNT) Write and Increment

If a timer counter clock pulse is generated during the  $T_2$  state of a TCNT write cycle, the write takes priority and the timer counter is not incremented. Figure 10.8 shows this operation.



**Figure 10.8 Contention between TCNT Write and Increment**

### 10.5.3 Changing Value of CKS2 to CKS0

If bits CKS0 to CKS2 in TCSR are written to while the WDT is operating, errors could occur in the incrementation. Software must be used to stop the watchdog timer (by clearing the TME bit to 0) before changing the value of bits CKS0 to CKS2.

### 10.5.4 Switching between Watchdog Timer Mode and Interval Timer Mode

If the mode is switched from watchdog timer to interval timer while the WDT is operating, errors could occur in the incrementation. Software must be used to stop the watchdog timer (by clearing the TME bit to 0) before switching the mode.

### 10.5.5 Internal Reset in Watchdog Timer Mode

This LSI is not reset internally if TCNT overflows while the RSTE bit is cleared to 0 during watchdog timer operation, however TCNT and TCSR of the WDT are reset.

TCNT, TCSR, or RSTCR cannot be written to for 132 states following an overflow. During this period, any attempt to read the WOVF flag is not acknowledged. Accordingly, wait 132 states after overflow to write 0 to the WOVF flag for clearing.

### 10.5.6 OVF Flag Clearing in Interval Timer Mode

When the OVF flag setting conflicts with the OVF flag reading in interval timer mode, writing 0 to the OVF bit may not clear the flag even though the OVF bit has been read while it is 1. If there is a possibility that the OVF flag setting and reading will conflict, such as when the OVF flag is polled with the interval timer interrupt disabled, read the OVF bit while it is 1 at least twice before writing 0 to the OVF bit to clear the flag.

## Section 11 Realtime Clock (RTC)

The realtime clock (RTC) is a timer used to count time ranging from a second to a week. Figure 11.1 shows the block diagram of the RTC.

### 11.1 Features

- Counts seconds, minutes, hours, and day-of-week
- Start/stop function
- Reset function
- Readable/writable counter of seconds, minutes, hours, and day-of-week with BCD codes
- Periodic (seconds, minutes, hours, days, and weeks) interrupts
- 8-bit free running counter
- Selection of clock source
- 8-bit bus (3 cycle access timing) connected to the external bus

RTC register is allocated to a part of area 7 of external address (H'FFFF48 to H'FFFF4F)

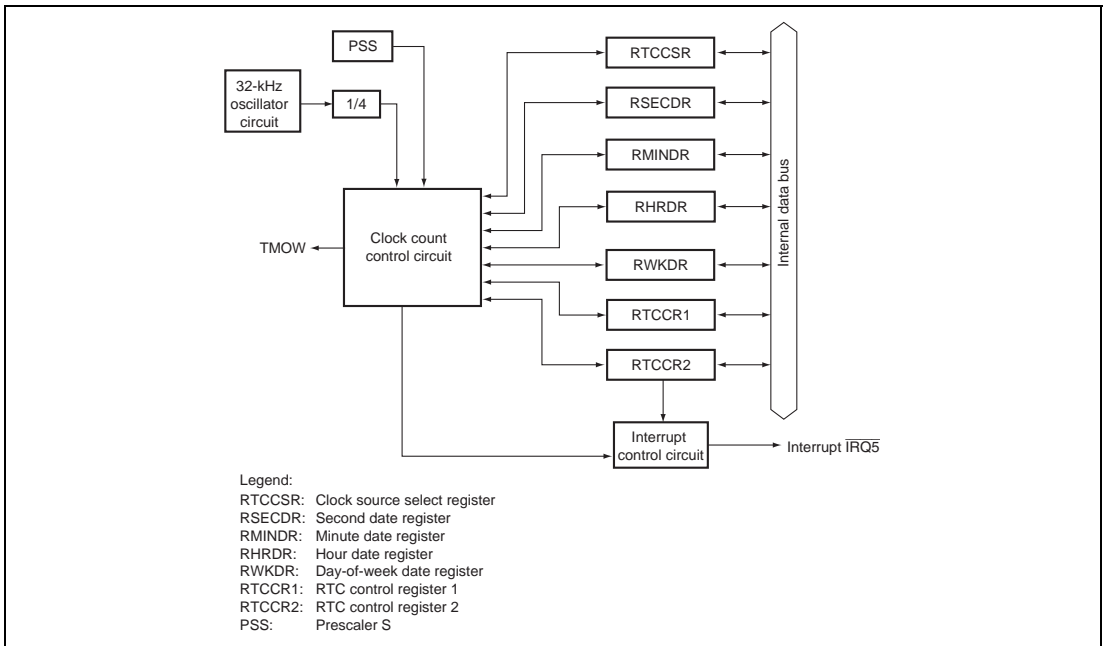


Figure 11.1 Block Diagram of RTC

## 11.2 Input/Output Pin

Table 11.1 shows the RTC input/output pin.

**Table 11.1 Pin Configuration**

Name	Abbreviation	I/O	Function
Clock output	TMOW	Output	RTC divided clock output

## 11.3 Register Descriptions

The RTC has the following registers.

- Second data register (RSECDR)
- Minute data register (RMINDR)
- Hour data register (RHRDR)
- Day-of-week data register (RWKDR)
- RTC control register 1 (RTCCR1)
- RTC control register 2 (RTCCR2)
- Clock source select register (RTCCSR)
- Extended module stop register (EXMDLSTP)

### 11.3.1 Second Data Register (RSECDR)

RSECDR counts the BCD-coded second value. This register is initialized to H'00 by a  $\overline{\text{STBY}}$  input or the RST bit in RTCCR1, but not initialized by a  $\overline{\text{RES}}$  input. The setting range is decimal 00 to 59. For more information on reading seconds, minutes, hours, and day-of-week, see section 11.4.2, Time Data Reading Procedure.

Bit	Bit Name	Initial Value*	R/W	Description
7	BSY	—	R	RTC Busy This bit is set to 1 when the RTC is updating (operating) the values of second, minute, hour, and day-of-week data registers. When this bit is 0, the values of second, minute, hour, and day-of-week data registers must be adopted.
6	SC12	—	R/W	Counting Ten's Position of Seconds
5	SC11	—	R/W	Counts on 0 to 5 for 60-second counting.
4	SC10	—	R/W	
3	SC03	—	R/W	Counting One's Position of Seconds
2	SC02	—	R/W	Counts on 0 to 9 once per second. When a carry is generated, 1 is added to the ten's position.
1	SC01	—	R/W	
0	SC00	—	R/W	

Note: \* Initial value after  $\overline{\text{RES}}$ .

### 11.3.2 Minute Data Register (RMINDR)

RMINDR counts the BCD-coded minute value on the carry generated once per minute by the RSECDR counting. This register is initialized to H'00 a  $\overline{\text{STBY}}$  input or the RST bit in RTCCR1, but not initialized by a  $\overline{\text{RES}}$  input. The setting range is decimal 00 to 59.

Bit	Bit Name	Initial Value*	R/W	Description
7	BSY	—	R	RTC Busy This bit is set to 1 when the RTC is updating (operating) the values of second, minute, hour, and day-of-week data registers. When this bit is 0, the values of second, minute, hour, and day-of-week data registers must be adopted.
6	MN12	—	R/W	Counting Ten's Position of Minutes
5	MN11	—	R/W	Counts on 0 to 5 for 60-minute counting.
4	MN10	—	R/W	
3	MN03	—	R/W	Counting One's Position of Minutes
2	MN02	—	R/W	Counts on 0 to 9 once per minute. When a carry is generated, 1 is added to the ten's position.
1	MN01	—	R/W	
0	MN00	—	R/W	

Note: \* Initial value after  $\overline{\text{RES}}$ .

### 11.3.3 Hour Data Register (RHRDR)

RHRDR counts the BCD-coded hour value on the carry generated once per hour by RMINDR. This register is initialized to H'00 by a  $\overline{\text{STBY}}$  input or the RST bit in RTCCR1, but not initialized by a  $\overline{\text{RES}}$  input. The setting range is either decimal 0 to 11 or 0 to 23 by the selection of the 12/24 bit in RTCCR1.

Bit	Bit Name	Initial Value*	R/W	Description
7	BSY	—	R	RTC Busy This bit is set to 1 when the RTC is updating (operating) the values of second, minute, hour, and day-of-week data registers. When this bit is 0, the values of second, minute, hour, and day-of-week data registers must be adopted.
6	—	0	—	Reserved This bit is always read as 0.
5	HR11	—	R/W	Counting Ten's Position of Hours
4	HR10	—	R/W	Counts on 0 to 2 for ten's position of hours.
3	HR03	—	R/W	Counting One's Position of Hours
2	HR02	—	R/W	Counts on 0 to 9 once per hour. When a carry is generated, 1 is added to the ten's position.
1	HR01	—	R/W	
0	HR00	—	R/W	

Note: \* Initial value after RES.



### 11.3.4 Day-of-Week Data Register (RWKDR)

RWKDR counts the BCD-coded day-of-week value on the carry generated once per day by RHRDR. This register is initialized to H'00 by a  $\overline{STBY}$  input or the RST bit in RTCCR1, but not initialized by a  $\overline{RES}$  input. The setting range is decimal 0 to 6 using bits WK2 to WK0.

Bit	Bit Name	Initial Value*	R/W	Description
7	BSY	—	R	RTC Busy  This bit is set to 1 when the RTC is updating (operating) the values of second, minute, hour, and day-of-week data registers. When this bit is 0, the values of second, minute, hour, and day-of-week data registers must be adopted.
6 to 3	—	All 0	—	Reserved These bits are always read as 0.
2	WK2	—	R/W	Day-of-Week Counting
1	WK1	—	R/W	Day-of-week is indicated with a binary code.
0	WK0	—	R/W	000: Sunday 001: Monday 010: Tuesday 011: Wednesday 100: Thursday 101: Friday 110: Saturday 111: Reserved (Setting prohibited)

Note: \* Initial value after  $\overline{RES}$ .

### 11.3.5 RTC Control Register 1 (RTCCR1)

RTCCR1 controls start/stop and reset of the clock timer. Bits 7 to 5 of this register are initialized to H'00 by a  $\overline{STBY}$  input or the RST bit in RTCCR1, but not initialized by a  $\overline{RES}$  input. For the definition of time expression, see figure 11.2.

Bit	Bit Name	Initial Value*	R/W	Description
7	RUN	—	R/W	RTC Operation Start 0: Stops RTC and free running counter operation 1: Starts RTC and free running counter operation
6	12/24	—	R/W	Operating Mode 0: RTC operates in 12-hour mode. RHRDR counts on 0 to 11. 1: RTC operates in 24-hour mode. RHRDR counts on 0 to 23.
5	PM	—	R/W	A.M./P.M. 0: Indicates a.m. when RTC is in the 12-hour mode. 1: Indicates p.m. when RTC is in the 12-hour mode.
4	RST	0	R/W	Reset 0: Normal operation 1: Resets registers and control circuits except RTCCSR and this bit. Clear this bit to 0 after having been set to 1.
3 to 0	—	All 0	—	Reserved These bits are always read as 0.

Note: \* Initial value after  $\overline{RES}$ .

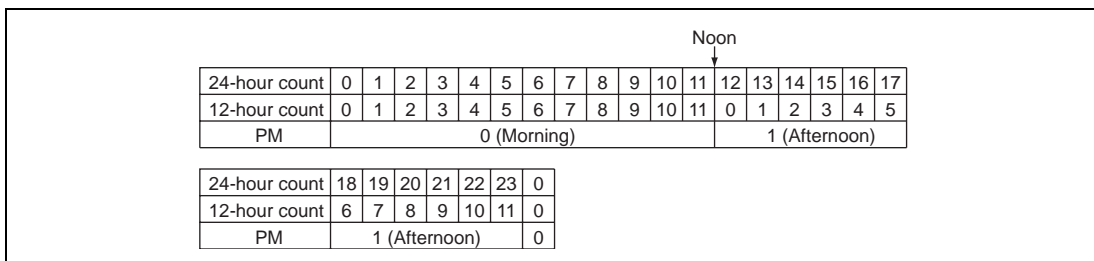


Figure 11.2 Definition of Time Expression

### 11.3.6 RTC Control Register 2 (RTCCR2)

RTCCR2 controls RTC periodic interrupts of weeks, days, hours, minutes, and seconds. This register is initialized to H'00 by a  $\overline{STBY}$  input or the RST bit in RTCCR1, but not initialized by a  $\overline{RES}$  input. Enabling interrupts of weeks, days, hours, minutes, and seconds sets the IRRTA flag to 1 in the interrupt flag register 1 (IRR1) when an interrupt occurs. It also controls an overflow interrupt of a free running counter when RTC operates as a free running counter.

Bit	Bit Name	Initial Value*	R/W	Description
7, 6	—	All 0	—	Reserved These bits are always read as 0.
5	FOIE	—	R/W	Free Running Counter Overflow Interrupt Enable 0: Disables an overflow interrupt 1: Enables an overflow interrupt
4	WKIE	—	R/W	Week Periodic Interrupt Enable 0: Disables a week periodic interrupt 1: Enables a week periodic interrupt
3	DYIE	—	R/W	Day Periodic Interrupt Enable 0: Disables a day periodic interrupt 1: Enables a day periodic interrupt
2	HRIE	—	R/W	Hour Periodic Interrupt Enable 0: Disables an hour periodic interrupt 1: Enables an hour periodic interrupt
1	MNIE	—	R/W	Minute Periodic Interrupt Enable 0: Disables a minute periodic interrupt 1: Enables a minute periodic interrupt
0	SEIE	—	R/W	Second Periodic Interrupt Enable 0: Disables a second periodic interrupt 1: Enables a second periodic interrupt

Note: \* Initial value after  $\overline{RES}$ .

### 11.3.7 Clock Source Select Register (RTCCSR)

RTCCSR selects clock source. This register is initialized to H'08 by a  $\overline{STBY}$  input or  $\overline{RES}$  input. A free running counter controls start/stop of counter operation by the RUN bit in RTCCR1. When a clock other than 32.768 MHz is selected, the RTC is disabled and operates as an 8-bit free running counter. An interrupt can be generated by setting 1 to the FOIE bit in RTCCR2 and enabling an overflow interrupt of the free running counter. A clock in which the system clock is divided by 32, 16, 8, or 4 is output in high-speed mode, medium-speed mode, sleep mode, subactive mode, or subsleep mode.

Bit	Bit Name	Initial Value	R/W	Description
7	—	0	—	Reserved This bit is always read as 0.
6	RCS6	0	R/W	Clock Output Selection
5	RCS5	0	R/W	Selects a clock output from the TMOW pin when the TMOWE bit in UCTLR is set to 1. 00: $\phi/4$ 01: $\phi/8$ 10: $\phi/16$ 11: $\phi/32$
4	—	0	—	Reserved This bit is always read as 0.
3	RCS3	1	R/W	Clock Source Selection
2	RCS2	0	R/W	0000: $\phi/8$ ..... Free running counter operation
1	RCS1	0	R/W	0001: $\phi/32$ ..... Free running counter operation
0	RCS0	0	R/W	0010: $\phi/128$ ..... Free running counter operation 0011: $\phi/256$ ..... Free running counter operation 0100: $\phi/512$ ..... Free running counter operation 0101: $\phi/2048$ ..... Free running counter operation 0110: $\phi/4096$ ..... Free running counter operation 0111: $\phi/8192$ ..... Free running counter operation 1000: 32.768 kHz.....RTC operation

### 11.3.8 Extended Module Stop Register (EXMDLSTP)

EXMDLSTP controls the clock supply of the RTC and USB.

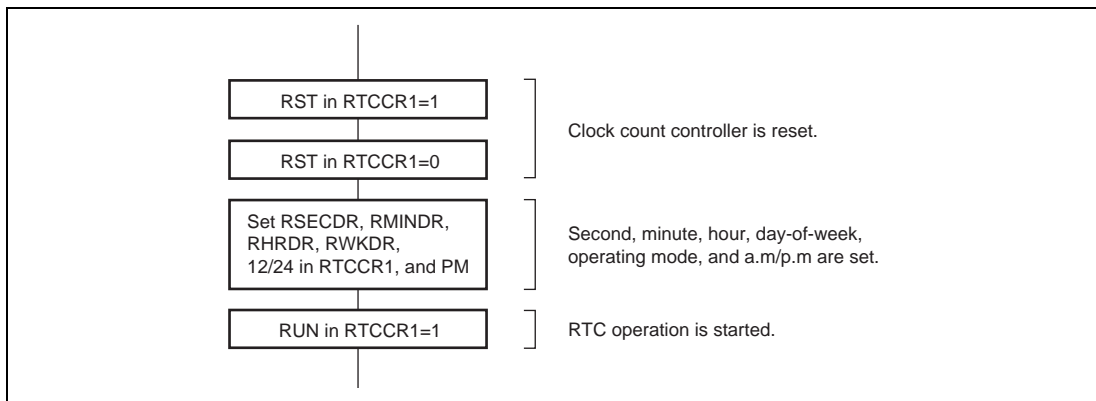
Note: When reading pin states using the port D register (PORTD), after accessing EXMDLSTP (address range: H'FFFF40 to H'FFFF5F), you must perform a dummy read to the external address space (such as H'FFFEF00 to H'FF7FF) outside the range H'FFFF40 to H'FFFF5F before reading PORTD.

Bit	Bit Name	Initial Value	R/W	Module
7 to 2	—	Undefined	—	Reserved  These bits are always read as undefined values. These bits should not to be modified.
1	RTCSTOP	0	R/W	RTC Module Stop 0: RTC module stop cancelled 1: RTC module stop
0	USBSTOP1	0	R/W	USB Module Stop 0: USB module stop partly cancelled 1: USB module completely stop

## 11.4 Operation

### 11.4.1 Initial Settings of Registers after Power-On and Resetting Procedure

The RTC registers that store second, minute, hour, day-of-week, operating mode, and A.M./P.M. data are not reset by an  $\overline{\text{STBY}}$  input. Therefore, all registers must be set to their initial values after power-on and  $\overline{\text{STBY}}$  input. Figure 11.3 shows the initial setting and resetting procedures of the RTC. Once the register setting are made, the RTC provides an accurate time as long as power is supplied regardless of a  $\overline{\text{RES}}$  input.



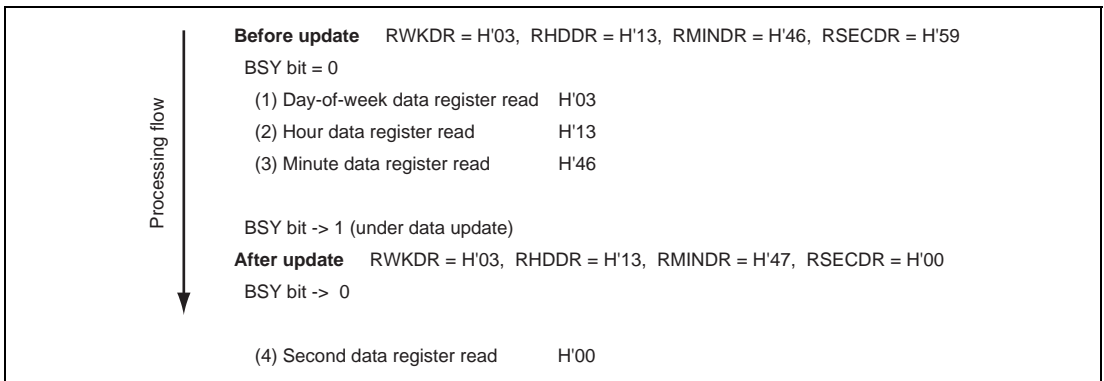
**Figure 11.3 Initial Setting Procedure**

## 11.4.2 Time Data Reading Procedure

When the seconds, minutes, hours, or day-of-week datum is updated while time data is being read, the data obtained may not be correct, and so the time data must be read again. Figure 11.4 shows an example in which correct data is not obtained. In this example, since only RSECDR is read after data update, about 1-minute inconsistency occurs.

To avoid reading in this timing, the following processing must be performed.

1. Check the setting of the BSY bit, and when the BSY bit changes from 1 to 0, read from the second, minute, hour, and day-of-week registers. When about 62.5 ms is passed after the BSY bit is set to 1, the registers are updated, and the BSY bit is cleared to 0.
2. Making use of interrupts, read from the second, minute, hour, and day-of week registers after the IRQ5F flag in ISR is set to 1 and the BSY bit is confirmed to be 0.
3. Read from the second, minute, hour, and day-of week registers twice in a row, and if there is no change in the read data, the read data is used.



**Figure 11.4 Example: Reading of Inaccurate Time Data**

## 11.5 Interrupt Source

The RTC interrupt sources are listed in table 11.2. There are five kinds of RTC interrupts: week interrupts, day interrupts, hour interrupts, minute interrupts, and second interrupts.

When using an interrupt, initiate the RTC last after other registers (include ISCRH and IER of interrupt controller) are set. Do not set multiple interrupt enable bits in RTCCR2 simultaneously to 1.

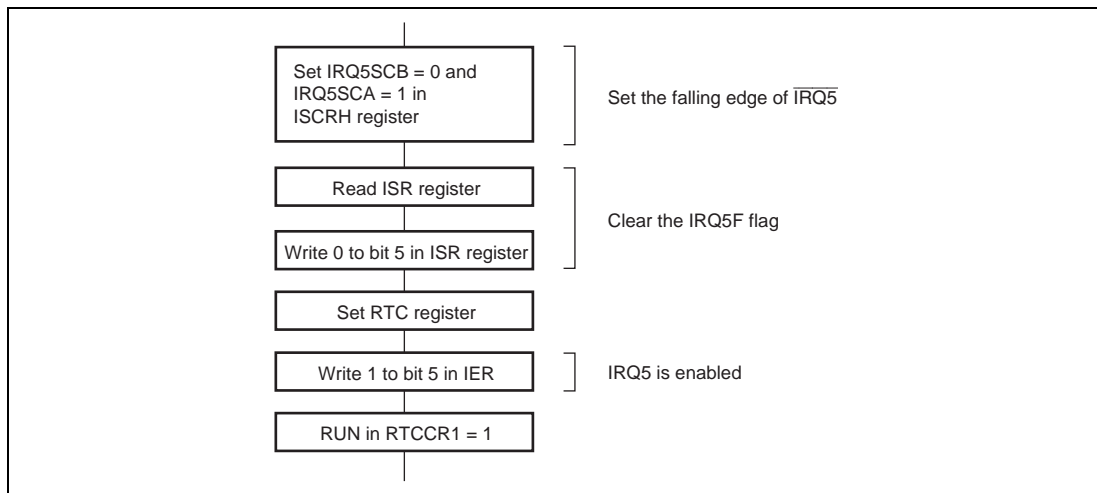
When an interrupt request of the RTC occurs, the IRQ5F flag in ISR is set to 1. When clearing the flag, write 0 after reading the flag = 1.

Figure 11.5 shows the initializing setting procedure in using the RTC interrupt and figure 11.6 shows an example of the RTC interrupt handling routine.

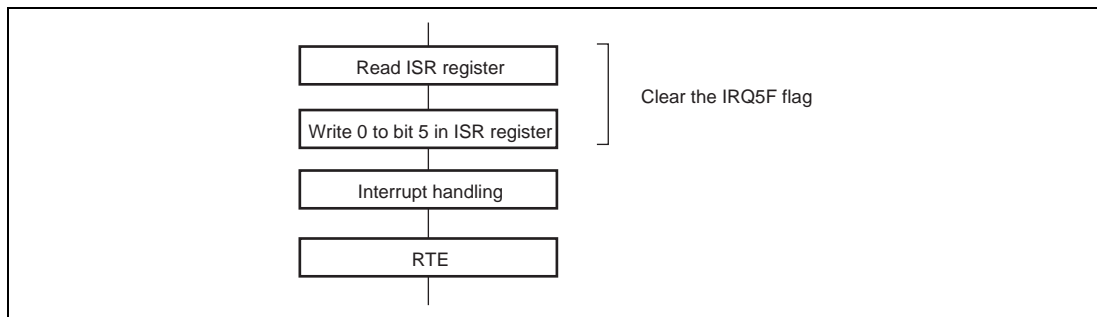
**Table 11.2 Interrupt Source**

Interrupt Name	Interrupt Source	Interrupt Enable Bit
Overflow interrupt	Occurs when the free running counter is overflowed.	FOIE
Week periodic interrupt	Occurs every week when the day-of-week date register value becomes 0.	WKIE
Day periodic interrupt	Occurs every day when the day-of-week date register is counted.	DYIE
Hour periodic interrupt	Occurs every hour when the hour date register is counted.	HRIE
Minute periodic interrupt	Occurs every minute when the minute date register is counted.	MNIE
Second periodic interrupt	Occurs every second when the second date register is counted.	SEIE





**Figure 11.5 Initializing Procedure in Using RTC Interrupt**



**Figure 11.6 Example of RTC Interrupt Handling Routine**

## 11.6 Operating State in Each Mode

Table 11.3 shows the operating state in each mode when the RTC is set for clock operation and free running timer operation. The clock operation is performed continuously even in low power mode. Therefore, when the clock operation is unnecessary, cancel it by EXMDLSTP.

**Table 11.3 Operating State in Each Mode**

Function	High-Speed	Medium-Speed	Module				Software Standby	Hard-ware Standby	
	Speed	Speed	Sleep	Stop	Watch	Subactive	Subsleep	Standby	
Clock operation	Subclock operation	Subclock operation	Subclock operation	Halted (Retained)	Subclock operation	Subclock operation	Subclock operation	Subclock operation	Halted (Reset)
Free running timer operation	Operating	Operating	Operating	Halted (Retained)	Halted (Retained)	Halted (Retained)	Halted (Retained)	Halted (Retained)	Halted (Reset)

## 11.7 Usage Notes

### (1) Notes on Using the Emulator

In the E6000 emulator the RTC module is mounted on an external extended board. Since it must be accessed as an external module, the limitations listed below apply. These limitations do not apply to the E10A or to product chips.

- RTC operation is not supported in the H8S/2218 Group's mode 7 (single-chip mode).
- When using the RTC module in the H8S/2218 Group's mode 6 (on-chip ROM-enabled mode) or the H8S/2212 Group's mode 7 (single-chip mode), A7 to A0 are input pins in the initial status. Therefore, A7 to A0 must be set as output pins by setting PC7DDR to PC0DDR to H'FF before accessing the RTC module.
- The above setting is not necessary when using the RTC module in the H8S/2218 Group's modes 4 and 5 (on-chip ROM-disabled mode) because A7 to A0 are output pins.

### (2) Bus Interface

The bus interface of the module conforms to the bus specifications for external area 7. Consequently, before accessing the RTC module, area 7 must be specified as having an 8-bit bus width and 3-state access using the bus controller register.

### (3) Method for Reading Pin States Using the Port D Register (PORTD)

First access EXMDLSTP or the RTC register (address range: H'FFFF40 to H'FFFF5F). Then, you must perform a dummy read to the external address space (such as H'FFFEF0 to H'FF7FF) outside the range H'FFFF40 to H'FFFF5F before reading PORTD.

## Section 12 Serial Communication Interface

This LSI has two independent serial communication interface (SCI) channels. The SCI can handle both asynchronous and clocked synchronous serial communication. Asynchronous serial data communication can be carried out using standard asynchronous communication chips such as a Universal Asynchronous Receiver/Transmitter (UART) or an Asynchronous Communication Interface Adapter (ACIA). A function is also provided for serial communication between processors (multiprocessor communication function). The SCI also supports the smart card (IC card) interface based on ISO/IEC 7816-3 (Identification Card) as an enhanced asynchronous communication function.

### 12.1 Features

- Choice of asynchronous or clocked synchronous serial communication mode
- Full-duplex communication capability  
The transmitter and receiver are mutually independent, enabling transmission and reception to be executed simultaneously.  
Double-buffering is used in both the transmitter and the receiver, enabling continuous transmission and continuous reception of serial data.  
On-chip baud rate generator allows any bit rate to be selected  
External clock can be selected as a transfer clock source (except for in Smart Card interface mode).
- Choice of LSB-first or MSB-first transfer (except in the case of asynchronous mode 7-bit data)
- Four interrupt sources  
Transmit-end, transmit-data-empty, receive-data-full, and receive error — that can issue requests.  
The transmit-data-empty interrupt and receive data full interrupts can be used to activate the direct memory access controller (DMAC).
- Module stop mode can be set

#### Asynchronous Mode

- Data length: 7 or 8 bits
- Stop bit length: 1 or 2 bits
- Parity: Even, odd, or none
- Receive error detection: Parity, overrun, and framing errors
- Break detection: Break can be detected by reading the RxD pin level directly in the case of a framing error

- Average transfer rate generator (SCI\_0):  
921.569 kbps, 720 kbps, 460.784 kbps, or 115.196 kbps can be selected at 16 MHz  
921.053 kbps, 720 kbps, 460.526 kbps, or 115.132 kbps can be selected at 24 MHz
- A transfer rate clock can be input from the TPU (SCI\_0)
- Communication between multiple processors is supported

### Clocked Synchronous Mode

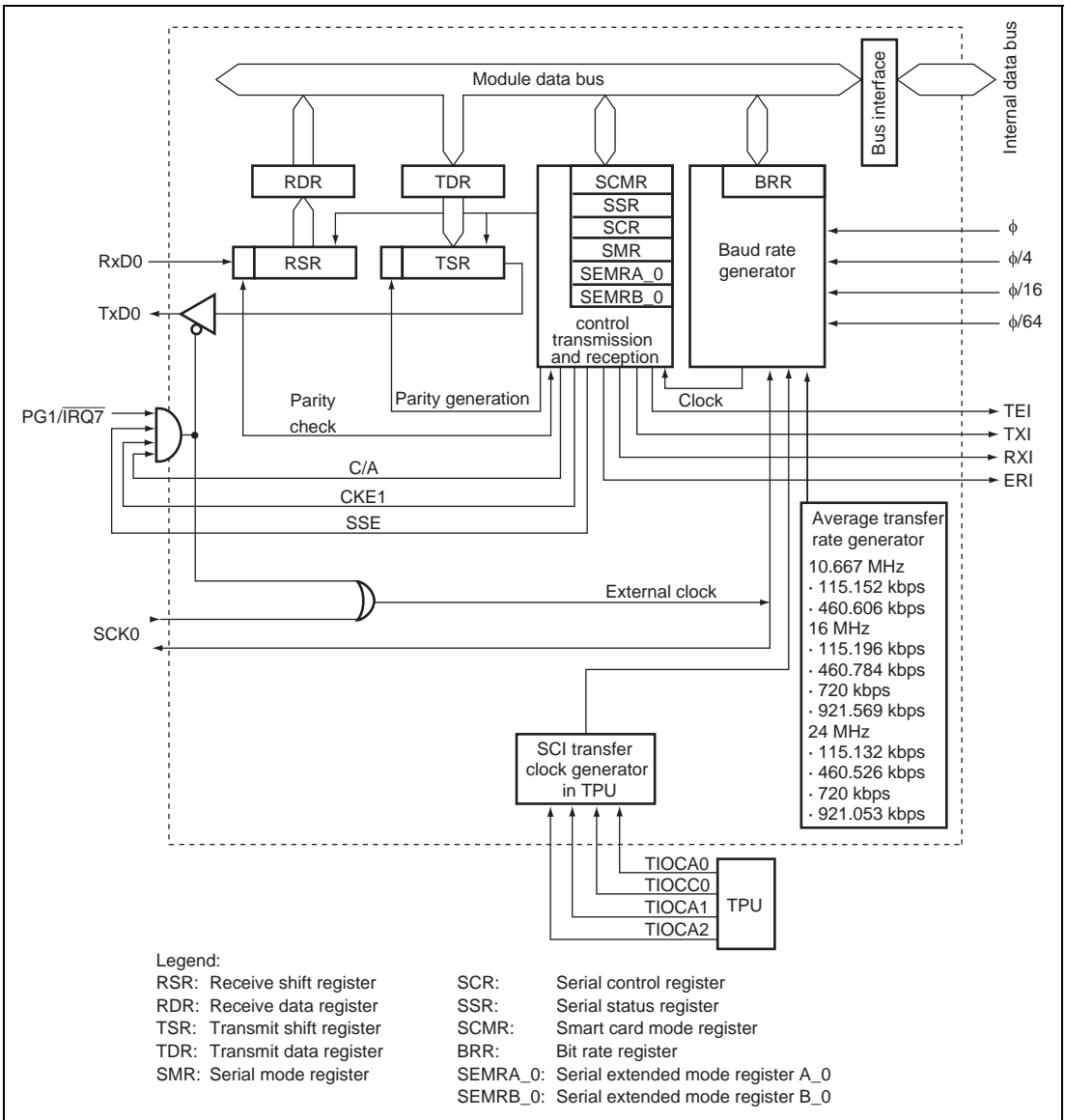
- Data length: 8 bits
- Receive error detection: Overrun errors detected
- SCI select function (SCI\_0): TxD0 = high-impedance and SCK0 = fixed high-level input can be selected when  $\overline{\text{IRQ7}} = 1$
- Serial data communication can be carried out with other chips that have a synchronous communication function

### Smart Card Interface

- An error signal can be automatically transmitted on detection of a parity error during reception
- Data can be automatically re-transmitted on detection of a error signal during transmission
- Both direct convention and inverse convention are supported

### 12.1.1 Block Diagram

Figure 12.1 shows the block diagram of the SCI\_0. Figure 12.2 shows the block diagram of the SCI\_2.



**Figure 12.1 Block Diagram of SCI\_0**

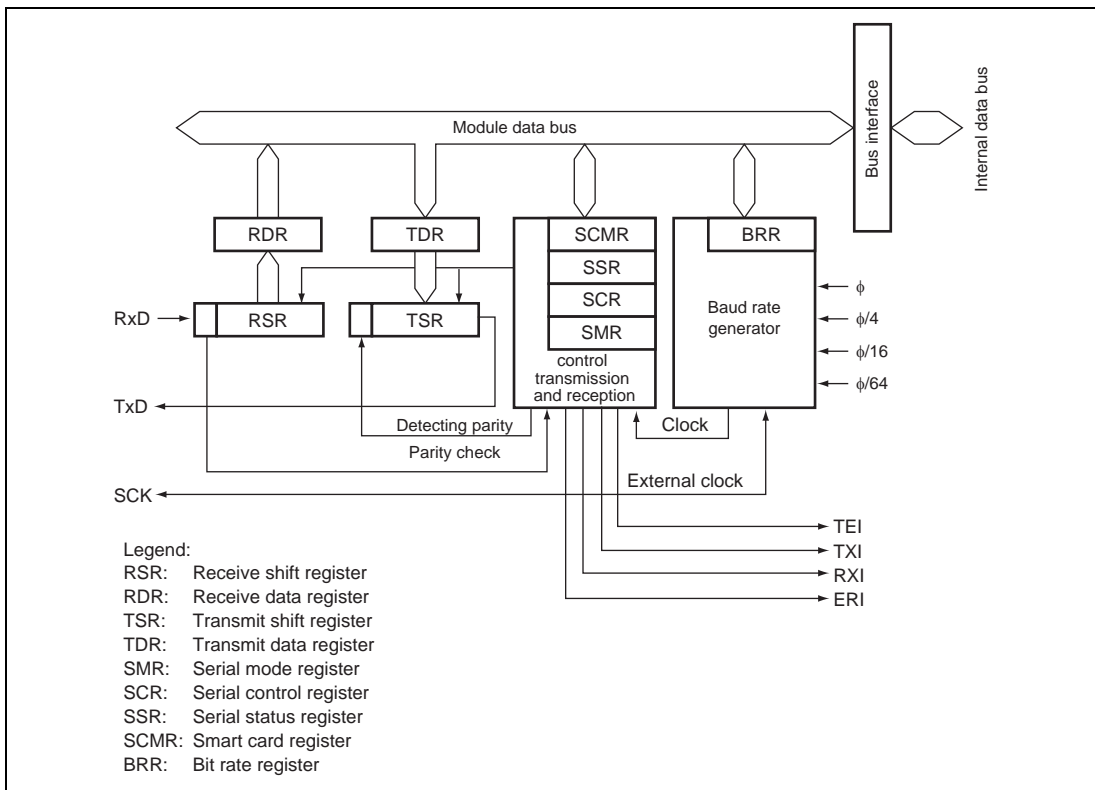


Figure 12.2 Block Diagram of SCI\_2

## 12.2 Input/Output Pins

Table 12.1 shows the serial pins for each SCI channel.

**Table 12.1 Pin Configuration**

Channel	Pin Name*	I/O	Function
0	SCK0	I/O	SCI_0 clock input/output
	RxD0	Input	SCI_0 receive data input
	TxD0	Output	SCI_0 transmit data output
2	SCK2	I/O	SCI_2 clock input/output
	RxD2	Input	SCI_2 receive data input
	TxD2	Output	SCI_2 transmit data output

Note: \* Pin names SCK, RxD, and TxD are used in the text for all channels, omitting the channel designation.

## 12.3 Register Descriptions

The SCI has the following registers for each channel. Some bits in the serial mode register (SMR), serial status register (SSR), and serial control register (SCR) have different functions in different modes—normal serial communication interface mode and smart card interface mode; therefore, the bits are described separately for each mode in the corresponding register sections.

- Receive shift register (RSR)
- Receive data register (RDR)
- Transmit data register (TDR)
- Transmit shift register (TSR)
- Serial mode register (SMR)
- Serial control register (SCR)
- Serial status register (SSR)
- Smart card mode register (SCMR)
- Serial extended mode register A\_0 (SEMRA\_0) (only for channel 0)
- Serial extended mode register B\_0 (SEMRB\_0) (only for channel 0)
- Bit rate register (BRR)

### 12.3.1 Receive Shift Register (RSR)

RSR is a shift register that is used to receive serial data input to the RxD pin and convert it into parallel data. When one byte of data has been received, it is transferred to RDR automatically. RSR cannot be directly accessed by the CPU.

### 12.3.2 Receive Data Register (RDR)

RDR is an 8-bit register that stores received data. When the SCI has received one byte of serial data, it transfers the received serial data from RSR to RDR, where it is stored. After this, RSR is receive-enabled. As RSR and RDR function as a double buffer in this way, continuous receive operations are possible. After confirming that the RDRF bit in SSR is set to 1, read RDR only once. RDR cannot be written to by the CPU. RDR is initialized to H'00 by a reset, and in standby mode, watch mode, subactive mode, subsleep mode, or module stop mode.

### 12.3.3 Transmit Data Register (TDR)

TDR is an 8-bit register that stores data for transmission. When the SCI detects that TSR is empty, it transfers the transmit data written in TDR to TSR and starts transmission. The double-buffered structure of TDR and TSR enables continuous serial transmission. If the next transmit data has already been written to TDR during serial transmission, the SCI transfers the written data to TSR to continue transmission. Although TDR can be read from or written to by the CPU at all times, to achieve reliable serial transmission, write transmit data to TDR only once after confirming that the TDRE bit in SSR is set to 1. TDR is initialized to H'FF by a reset, and in standby mode, watch mode, subactive mode, subsleep mode, or module stop mode.

### 12.3.4 Transmit Shift Register (TSR)

TSR is a shift register that transmits serial data. To perform serial data transmission, the SCI first transfers transmit data from TDR to TSR, then sends the data to the TxD pin. TSR cannot be directly accessed by the CPU.



### 12.3.5 Serial Mode Register (SMR)

SMR is used to set the SCI's serial transfer format and select the baud rate generator clock source. Some bits in SMR have different functions in normal mode and smart card interface mode.

- Normal Serial Communication Interface Mode (When SMIF in SCMR is 0)

Bit	Bit Name	Initial Value	R/W	Description
7	$C/\bar{A}$	0	R/W	Communication Mode 0: Asynchronous mode 1: Clocked synchronous mode
6	CHR	0	R/W	Character Length (enabled only in asynchronous mode) 0: Selects 8 bits as the data length 1: Selects 7 bits as the data length. LSB-first is fixed and the MSB of TDR is not transmitted in transmission  In clocked synchronous mode, a fixed data length of 8 bits is used.
5	PE	0	R/W	Parity Enable (enabled only in asynchronous mode) When this bit is set to 1, the parity bit is added to transmit data before transmission, and the parity bit is checked in reception. For a multiprocessor format, parity bit addition and checking are not performed regardless of the PE bit setting.
4	$O/\bar{E}$	0	R/W	Parity Mode (enabled only when the PE bit is 1 in asynchronous mode) 0: Selects even parity 1: Selects odd parity
3	STOP	0	R/W	Stop Bit Length (enabled only in asynchronous mode) Selects the stop bit length in transmission. 0: 1 stop bit 1: 2 stop bits  In reception, only the first stop bit is checked. If the second stop bit is 0, it is treated as the start bit of the next transmit character.

Bit	Bit Name	Initial Value	R/W	Description
2	MP	0	R/W	Multiprocessor Mode (enabled only in asynchronous mode) When this bit is set to 1, the multiprocessor communication function is enabled. The PE bit and O/ $\bar{E}$ bit settings are invalid in multiprocessor mode. For details, see section 12.5, Multi Processor Communication Function.
1	CKS1	0	R/W	Clock Select 0 and 1:
0	CKS0	0	R/W	These bits select the clock source for the baud rate generator. 00: $\phi$ clock (n = 0) 01: $\phi/4$ clock (n = 1) 10: $\phi/16$ clock (n = 2) 11: $\phi/64$ clock (n = 3) For the relationship between the bit rate register setting and the baud rate, see section 12.3.11, Bit Rate Register (BRR). n is the decimal representation of the value of n in BRR (see section 12.3.11, Bit Rate Register (BRR)).

---

- Smart Card Interface Mode (When SMIF in SCMR is 1)

Bit	Bit Name	Initial Value	R/W	Description
7	GM	0	R/W	<p>GSM Mode</p> <p>Setting this bit to 1 allows GSM mode operation. In GSM mode, the TEND set timing is put forward to 11.0 etu from the start and the clock output control function is appended. For details, see section 12.7.9, Clock Output Control.</p> <p>0: Normal smart card interface mode operation (initial value)</p> <p>(1) The TEND flag is generated 12.5 etu (11.5 etu in the block transfer mode) after the beginning of the start bit.</p> <p>(2) Clock output on/off control only.</p> <p>1: GSM mode operation in smart card interface mode</p> <p>(1) The TEND flag is generated 11.0 etu after the beginning of the start bit.</p> <p>(2) In addition to clock output on/off control, high/how fixed control is supported (set using SCR).</p>
6	BLK	0	R/W	<p>Setting this bit to 1 allows block transfer mode operation. For details, see section 12.7.4, Block Transfer Mode.</p> <p>0: Normal smart card interface mode operation (initial value)</p> <p>(1) Error signal transmission, detection, and automatic data retransmission are performed.</p> <p>(2) The TXI interrupt is generated by the TEND flag.</p> <p>(3) The TEND flag is set 12.5 etu (11.0 etu in the GSM mode) after transmission starts.</p> <p>1: Operation in block transfer mode</p> <p>(1) Error signal transmission, detection, and automatic data retransmission are not performed.</p> <p>(2) The TXI interrupt is generated by the TDRE flag.</p> <p>(3) The TEND flag is set 11.5 etu (11.0 etu in the GSM mode) after transmission starts.</p>

Bit	Bit Name	Initial Value	R/W	Description
5	PE	0	R/W	Parity Enable When this bit is set to 1, the parity bit is added to transmit data before transmission, and the parity bit is checked in reception. Set this bit to 1 in smart card interface mode.
4	$O/\bar{E}$	0	R/W	Parity Mode (valid only when the PE bit is 1) 0: Selects even parity 1: Selects odd parity For details on the usage of this bit in smart card interface mode, see section 12.7.2, Data Format (Except for Block Transfer Mode).
3	BCP1	0	R/W	Basic Clock Pulse 1 and 0
2	BCP0	0	R/W	These bits select the number of basic clock cycles in a 1-bit data transfer time in smart card interface mode. 00: 32 clock cycles (S = 32) 01: 64 clock cycles (S = 64) 10: 372 clock cycles (S = 372) 11: 256 clock cycles (S = 256) For details, see section 12.7.5, Receive Data Sampling Timing and Reception Margin. S is described in section 12.3.11, Bit Rate Register (BRR).
1	CKS1	0	R/W	Clock Select 1 and 0
0	CKS0	0	R/W	These bits select the clock source for the baud rate generator. 00: $\phi$ clock (n = 0) 01: $\phi/4$ clock (n = 1) 10: $\phi/16$ clock (n = 2) 11: $\phi/64$ clock (n = 3) For the relation between the bit rate register setting and the baud rate, see section 12.3.11, Bit Rate Register (BRR). n is the decimal display of the value of n in BRR (see section 12.3.11, Bit Rate Register (BRR)).

### 12.3.6 Serial Control Register (SCR)

SCR is a register that enables or disables SCI transfer operations and interrupt requests, and is also used to selection of the transfer clock source. For details on interrupt requests, refer to section 12.9, Interrupts. Some bits in SCR have different functions in normal mode and smart card interface mode.

- Normal Serial Communication Interface Mode (When SMIF in SCMR is 0)

Bit	Bit Name	Initial Value	R/W	Description
7	TIE	0	R/W	<p>Transmit Interrupt Enable</p> <p>When this bit is set to 1, the TXI interrupt request is enabled.</p> <p>TXI interrupt request cancellation can be performed by reading 1 from the TDRE flag, then clearing it to 0, or clearing the TIE bit to 0.</p>
6	RIE	0	R/W	<p>Receive Interrupt Enable</p> <p>When this bit is set to 1, RXI and ERI interrupt requests are enabled.</p> <p>RXI and ERI interrupt request cancellation can be performed by reading 1 from the RDRF flag, or the FER, PER, or ORER flag, then clearing the flag to 0, or clearing the RIE bit to 0.</p>
5	TE	0	R/W	<p>Transmit Enable</p> <p>When this bit is set to 1, transmission is enabled.</p> <p>In this state, serial transmission is started when transmit data is written to TDR and the TDRE flag in SSR is cleared to 0. SMR setting must be performed to decide the transfer format before setting the TE bit to 1. The TDRE flag in SSR is fixed at 1 if transmission is disabled by clearing this bit to 0.</p>
4	RE	0	R/W	<p>Receive Enable</p> <p>When this bit is set to 1, reception is enabled.</p> <p>Serial reception is started in this state when a start bit is detected in asynchronous mode or serial clock input is detected in clocked synchronous mode. SMR setting must be performed to decide the transfer format before setting the RE bit to 1.</p> <p>Clearing the RE bit to 0 does not affect the RDRF, FER, PER, and ORER flags, which retain their states.</p>

Bit	Bit Name	Initial Value	R/W	Description
3	MPIE	0	R/W	<p>Multiprocessor Interrupt Enable (enabled only when the MP bit in SMR is 1 in asynchronous mode)</p> <p>When this bit is set to 1, receive data in which the multiprocessor bit is 0 is skipped, and setting of the RDRF, FER, and ORER status flags in SSR is prohibited. On receiving data in which the multiprocessor bit is 1, this bit is automatically cleared and normal reception is resumed. For details, refer to section 12.5, Multiprocessor Communication Function.</p> <p>When receive data including MPB = 0 is received, receive data transfer from RSR to RDR, receive error detection, and setting of the RDRF, FER, and ORER flags in SSR, is not performed. When receive data including MPB = 1 is received, the MPB bit in SSR is set to 1, the MPIE bit is cleared to 0 automatically, and generation of RXI and ERI interrupts (when the TIE and RIE bits in SCR are set to 1) and FER and ORER flag setting is enabled.</p>
2	TEIE	0	R/W	<p>Transmit End Interrupt Enable</p> <p>This bit is set to 1, TEI interrupt request is enabled. TEI cancellation can be performed by reading 1 from the TDRE flag in SSR, then clearing it to 0 and clearing the TEND flag to 0, or clearing the TEIE bit to 0.</p>
1	CKE1	0	R/W	Clock Enable 0 and 1
0	CKE0	0	R/W	<p>Selects the clock source and SCK pin function.</p> <p>Asynchronous mode</p> <p>00: Internal baud rate generator SCK pin functions as I/O port</p> <p>01: Internal baud rate generator Outputs a clock of the same frequency as the bit rate from the SCK pin.</p> <p>1x: External clock Inputs a clock with a frequency 16 times the bit rate from the SCK pin.</p> <p>Clocked synchronous mode</p> <p>0x: Internal clock (SCK pin functions as clock output)</p> <p>1x: External clock (SCK pin functions as clock input)</p>

Legend:

x: Don't care

- Smart Card Interface Mode (When SMIF in SCMR is 1)

Bit	Bit Name	Initial Value	R/W	Description
7	TIE	0	R/W	<p>Transmit Interrupt Enable</p> <p>When this bit is set to 1, TXI interrupt request is enabled. TXI interrupt request cancellation can be performed by reading 1 from the TDRE flag in SSR, then clearing it to 0, or clearing the TIE bit to 0.</p>
6	RIE	0	R/W	<p>Receive Interrupt Enable</p> <p>When this bit is set to 1, RXI and ERI interrupt requests are enabled. RXI and ERI interrupt request cancellation can be performed by reading 1 from the RDRF, FER, PER, or ORER flag in SSR, then clearing the flag to 0, or clearing the RIE bit to 0.</p>
5	TE	0	R/W	<p>Transmit Enable</p> <p>When this bit is set to 1, transmission is enabled. In this state, serial transmission is started when transmit data is written to TDR and the TDRE flag in SSR is cleared to 0. SMR setting must be performed to decide the transfer format before setting the TE bit to 1. When this bit is cleared to 0, the transmission operation is disabled, and the TDRE flag is fixed at 1.</p>
4	RE	0	R/W	<p>Receive Enable</p> <p>When this bit is set to 1, reception is enabled. Serial reception is started in this state when a start bit is detected in asynchronous mode or serial clock input is detected in clocked synchronous mode. SMR setting must be performed to decide the reception format before setting the RE bit to 1. Clearing the RE bit to 0 does not affect the RDRF, FER, PER, and ORER flags, which retain their states.</p>

Bit	Bit Name	Initial Value	R/W	Description
3	MPIE	0	R/W	<p>Multiprocessor Interrupt Enable (enabled only when the MP bit in SMR is 1 in asynchronous mode)</p> <p>Write 0 to this bit in Smart Card interface mode.</p> <p>When receive data including MPB = 0 is received, receive data transfer from RSR to RDR, receive error detection, and setting of the RERF, FER, and ORER flags in SSR, are not performed.</p> <p>When receive data including MPB = 1 is received, the MPB bit in SSR is set to 1, the MPIE bit is cleared to 0 automatically, and generation of RXI and ERI interrupts (when the TIE and RIE bits in SCR are set to 1) and FER and ORER flag setting are enabled.</p>
2	TEIE	0	R/W	<p>Transmit End Interrupt Enable</p> <p>Write 0 to this bit in Smart Card interface mode.</p> <p>TEI cancellation can be performed by reading 1 from the TDRE flag in SSR, then clearing it to 0 and clearing the TEND flag to 0, or clearing the TEIE bit to 0.</p>
1	CKE1	0	R/W	Clock Enable 0 and 1
0	CKE0	0		<p>Enables or disables clock output from the SCK pin. The clock output can be dynamically switched in GSM mode. For details, refer to section 12.7.9, Clock Output Control.</p> <p>When the GM bit in SMR is 0:</p> <p>00: Output disabled (SCK pin can be used as an I/O port pin)</p> <p>01: Clock output</p> <p>1x: Reserved</p> <p>When the GM bit in SMR is 1:</p> <p>00: Output fixed low</p> <p>01: Clock output</p> <p>10: Output fixed high</p> <p>11: Clock output</p>

Legend:

x: Don't care



### 12.3.7 Serial Status Register (SSR)

SSR is a register containing status flags of the SCI and multiprocessor bits for transfer. 1 cannot be written to flags TDRE, RDRF, ORER, PER, and FER; they can only be cleared. Some bits in SSR have different functions in normal mode and smart card interface mode.

- Normal Serial Communication Interface Mode (When SMIF in SCMR is 0)

Bit	Bit Name	Initial Value	R/W	Description
7	TDRE	1	R/(W)* <sup>1</sup>	<p>Transmit Data Register Empty</p> <p>Displays whether TDR contains transmit data.</p> <p>[Setting conditions]</p> <ul style="list-style-type: none"> <li>• When the TE bit in SCR is 0</li> <li>• When data is transferred from TDR to TSR and data can be written to TDR</li> </ul> <p>[Clearing conditions]</p> <ul style="list-style-type: none"> <li>• When 0 is written to TDRE after reading TDRE = 1*<sup>2</sup></li> <li>• When the DMAC is activated by a TXI interrupt request and writes data to TDR</li> </ul>
6	RDRF	0	R/(W)* <sup>1</sup>	<p>Receive Data Register Full</p> <p>Indicates that the received data is stored in RDR.</p> <p>[Setting condition]</p> <p>When serial reception ends normally and receive data is transferred from RSR to RDR</p> <p>[Clearing conditions]</p> <ul style="list-style-type: none"> <li>• When 0 is written to RDRF after reading RDRF = 1*<sup>2</sup></li> <li>• When the DMAC is activated by an RXI interrupt and transferred data from RDR</li> </ul> <p>RDR and the RDRF flag are not affected and retain their previous values when the RE bit in SCR is cleared to 0.</p> <p>The RDRF flag is not affected and retains their previous values when the RE bit in SCR is cleared to 0.</p>

Bit	Bit Name	Initial Value	R/W	Description
5	ORER	0	R/(W)* <sup>1</sup>	<p>Overrun Error</p> <p>[Setting condition]</p> <ul style="list-style-type: none"> <li>When the next serial reception is completed while RDRF = 1 The receive data prior to the overrun error is retained in RDR, and the data received subsequently is lost. Also, subsequent serial reception cannot be continued while the ORER flag is set to 1. In clocked synchronous mode, serial transmission cannot be continued, either.</li> </ul> <p>[Clearing condition]</p> <ul style="list-style-type: none"> <li>When 0 is written to ORER after reading ORER = 1*<sup>2</sup> The ORER flag is not affected and retains its previous state when the RE bit in SCR is cleared to 0.</li> </ul>
4	FER	0	R/(W)* <sup>1</sup>	<p>Framing Error</p> <p>[Setting condition]</p> <ul style="list-style-type: none"> <li>When the stop bit is 0 In 2-stop-bit mode, only the first stop bit is checked for a value of 0; the second stop bits not checked. If a framing error occurs, the receive data is transferred to RDR but the RDRF flag is not set. Also, subsequent serial reception cannot be continued while the FER flag is set to 1. In clocked synchronous mode, serial transmission cannot be continued, either.</li> </ul> <p>[Clearing condition]</p> <ul style="list-style-type: none"> <li>When 0 is written to FER after reading FER = 1*<sup>2</sup> The FER flag is not affected and retains its previous state when the RE bit in SCR is cleared to 0.</li> </ul>

Bit	Bit Name	Initial Value	R/W	Description
3	PER	0	R/(W)* <sup>1</sup>	<p>Parity Error</p> <p>[Setting condition]</p> <ul style="list-style-type: none"> <li>When a parity error is detected during reception If a parity error occurs, the receive data is transferred to RDR but the RDRF flag is not set. Also, subsequent serial reception cannot be continued while the PER flag is set to 1. In clocked synchronous mode, serial transmission cannot be continued, either.</li> </ul> <p>[Clearing condition]</p> <ul style="list-style-type: none"> <li>When 0 is written to PER after reading PER = 1*<sup>2</sup> The PER flag is not affected and retains its previous state when the RE bit in SCR is cleared to 0.</li> </ul>
2	TEND	1	R	<p>Transmit End</p> <p>[Setting conditions]</p> <ul style="list-style-type: none"> <li>When the TE bit in SCR is 0</li> <li>When TDRE = 1 at transmission of the last bit of a 1-byte serial transmit character</li> </ul> <p>[Clearing conditions]</p> <ul style="list-style-type: none"> <li>When 0 is written to TDRE after reading TDRE = 1</li> <li>When the DMAC is activated by a TXI interrupt and writes data to TDR</li> </ul>
1	MPB	0	R	<p>Multiprocessor Bit</p> <p>MPB stores the multiprocessor bit in the receive data. When the RE bit in SCR is cleared to 0 its previous state is retained. This bit retains its previous state when the RE bit in SCR is cleared to 0.</p>
0	MPBT	0	R/W	<p>Multiprocessor Bit Transfer</p> <p>MPBT stores the multiprocessor bit to be added to the transmit data.</p>

Note: 1. The write value should always be 0 to clear the flag.  
2. To clear the flag by the CPU on the HD6432210S, reread the flag after writing 0 to it.

- Smart Card Interface Mode (When SMIF in SCMR is 1)

Bit	Bit Name	Initial Value	R/W	Description
7	TDRE	1	R/(W)* <sup>1</sup>	<p>Transmit Data Register Empty</p> <p>Indicates whether TDR contains transmit data.</p> <p>[Setting conditions]</p> <ul style="list-style-type: none"> <li>• When the TE bit in SCR is 0</li> <li>• When data is transferred from TDR to TSR and data can be written to TDR</li> </ul> <p>[Clearing conditions]</p> <ul style="list-style-type: none"> <li>• When 0 is written to TDRE after reading TDRE = 1*<sup>2</sup></li> <li>• When the DMAC is activated by a TXI interrupt request and writes data to TDR</li> </ul>
6	RDRF	0	R/(W)* <sup>1</sup>	<p>Receive Data Register Full</p> <p>Indicates that the received data is stored in RDR.</p> <p>[Setting condition]</p> <p>When serial reception ends normally and receive data is transferred from RSR to RDR</p> <p>[Clearing conditions]</p> <ul style="list-style-type: none"> <li>• When 0 is written to RDRF after reading RDRF = 1*<sup>2</sup></li> <li>• When the DMAC is activated by an RXI interrupt and transferred data from RDR</li> </ul> <p>The RDRF flag is not affected and retains their previous values when the RE bit in SCR is cleared to 0.</p> <p>If reception of the next data is completed while the RDRF flag is still set to 1, an overrun error will occur and the receive data will be lost.</p>

Bit	Bit Name	Initial Value	R/W	Description
5	ORER	0	R/(W)* <sup>1</sup>	<p>Overrun Error</p> <p>Indicates that an overrun error occurred during reception, causing abnormal termination.</p> <p>[Setting condition]</p> <ul style="list-style-type: none"> <li>When the next serial reception is completed while RDRF = 1</li> </ul> <p>The receive data prior to the overrun error is retained in RDR, and the data received subsequently is lost. Also, subsequent serial cannot be continued while the ORER flag is set to 1. In clocked synchronous mode, serial transmission cannot be continued, either.</p> <p>[Clearing condition]</p> <ul style="list-style-type: none"> <li>When 0 is written to ORER after reading ORER = 1*<sup>2</sup></li> </ul> <p>The ORER flag is not affected and retains its previous state when the RE bit in SCR is cleared to 0.</p>
4	ERS	0	R/(W)* <sup>1</sup>	<p>Error Signal Status</p> <p>Indicates that the status of an error, signal 1 returned from the reception side at reception</p> <p>[Setting condition]</p> <ul style="list-style-type: none"> <li>When the low level of the error signal is sampled</li> </ul> <p>[Clearing condition]</p> <ul style="list-style-type: none"> <li>When 0 is written to ERS after reading ERS = 1*<sup>2</sup></li> </ul> <p>The ERS flag is not affected and retains its previous state when the RE bit in SCR is cleared to 0.</p>

Bit	Bit Name	Initial Value	R/W	Description
3	PER	0	R/(W)* <sup>1</sup>	<p>Parity Error</p> <p>Indicates that a parity error occurred during reception using parity addition in asynchronous mode, causing abnormal termination.</p> <p>[Setting condition]</p> <ul style="list-style-type: none"> <li>When a parity error is detected during reception If a parity error occurs, the receive data is transferred to RDR but the RDRF flag is not set. Also, subsequent serial reception cannot be continued while the PER flag is set to 1. In clocked synchronous mode, serial transmission cannot be continued, either.</li> </ul> <p>[Clearing condition]</p> <ul style="list-style-type: none"> <li>When 0 is written to PER after reading PER = 1*<sup>2</sup> The PER flag is not affected and retains its previous state when the RE bit in SCR is cleared to 0.</li> </ul>
2	TEND	1	R	<p>Transmit End</p> <p>This bit is set to 1 when no error signal has been sent back from the receiving end and the next transmit data is ready to be transferred to TDR.</p> <p>[Setting conditions]</p> <ul style="list-style-type: none"> <li>When the TE bit in SCR is 0 and the ERS bit is also 0</li> <li>When the ERS bit is 0 and the TDRE bit is 1 after the specified interval following transmission of 1-byte data.</li> </ul> <p>The timing of bit setting differs according to the register setting as follows:</p> <p>When GM = 0 and BLK = 0, 12.5 etu after transmission starts</p> <p>When GM = 0 and BLK = 1, 11.5 etu after transmission starts</p> <p>When GM = 1 and BLK = 0, 11.0 etu after transmission starts</p> <p>When GM = 1 and BLK = 1, 11.0 etu after transmission starts</p> <p>[Clearing conditions]</p> <ul style="list-style-type: none"> <li>When 0 is written to TDRE after reading TDRE = 1</li> <li>When the DMAC is activated by a TXI interrupt and transfers transmission data to TDR</li> </ul>

Bit	Bit Name	Initial Value	R/W	Description
1	MPB	0	R	Multiprocessor Bit This bit is not used in Smart Card interface mode.
0	MPBT	0	R/W	Multiprocessor Bit Transfer Write 0 to this bit in Smart Card interface mode.

Note:

1. The write value should always be 0 to clear the flag.
2. To clear the flag by the CPU on the HD6432210S, reread the flag after writing 0 to it.

### 12.3.8 Smart Card Mode Register (SCMR)

SCMR is a register that selects the transfer format. In this LSI, Smart Card interface mode cannot be specified.

Bit	Bit Name	Initial Value	R/W	Description
7 to 4	—	All 1	—	Reserved These bits are always read as 1.
3	DIR	0	R/W	Data Transfer Direction Selects the serial/parallel conversion format. 0: LSB-first in transfer 1: MSB-first in transfer The bit setting is valid only when the transfer data format is 8 bits.
2	INV	0	R/W	Data Invert Specifies inversion of the data logic level. The SINV bit does not affect the logic level of the parity bit. To invert the parity bit, invert the O/E bit in SMR. 0: TDR contents are transmitted as they are. Receive data is stored as it is in RDR 1: TDR contents are inverted before being transmitted. Receive data is stored in inverted form in RDR
1	—	1	—	Reserved This bit is always read as 1.
0	SMIF	0	R/W	Smart Card Interface Mode Select When this bit is set to 1, smart card interface mode is selected. 0: Normal asynchronous or clocked synchronous mode 1: Smart card interface mode

### 12.3.9 Serial Extended Mode Register A\_0 (SEMRA\_0)

SEMRA\_0 extends the functions of SCI\_0. SEMR0 enables selection of the SCI\_0 select function in synchronous mode, base clock setting in asynchronous mode, and also clock source selection and automatic transfer rate setting. Figure 12.3 shows an example of the internal base clock when an average transfer rate is selected and figure 12.4 shows as example of the setting when the TPU clock input is selected.

Bit	Bit Name	Initial Value	R/W	Description																																				
7	SSE	0	R/W	<p>SCI_0 Select Enable</p> <p>Allows selection of the SCI0 select function when an external clock is input in synchronous mode.</p> <p>The SSE setting is valid when external clock input is used (CKE1 = 1 in SCR) in synchronous mode (C/A = 1 in SMR).</p> <p>0: SCI_0 select function disabled 1: SCI_0 select function enabled</p> <p>When the SCI_0 select function is enabled, if 1 is input to the PG1/IRQ7 pin, TxD0 output goes to the high-impedance state, SCK0 input is fixed high.</p>																																				
6	TCS2	0	R/W	TPU Clock Select																																				
5	TCS1	0	R/W	When the TPU clock is input (ACS3 to ACS0 = B'0100) as the clock source in asynchronous mode, serial transfer clock is generated depending on the combination of the TPU clock.																																				
4	TCS0	0	R/W																																					
<table border="1"> <thead> <tr> <th></th> <th>Base Clock</th> <th>Clock Enable</th> <th>TCLKA</th> <th>TCLKB</th> <th>TCLKC</th> </tr> </thead> <tbody> <tr> <td>000</td> <td>TIOCA1</td> <td>TIOCA2</td> <td>Base clock written in the left column</td> <td>Pin input</td> <td>Pin input</td> </tr> <tr> <td>001</td> <td>TIOCA0   TIOCC0</td> <td>TIOCA1</td> <td>Pin input</td> <td>Base clock written in the left column</td> <td>Pin input</td> </tr> <tr> <td>010</td> <td>TIOCA0</td> <td>TIOCA1 &amp; TIOCA2</td> <td>Pin input</td> <td>Base clock written in the left column</td> <td>Pin input</td> </tr> <tr> <td>011</td> <td>TIOCA0   TIOCC0</td> <td>TIOCA1 &amp; TIOCA2</td> <td>Pin input</td> <td>Base clock written in the left column</td> <td>Pin input</td> </tr> <tr> <td>1xx</td> <td colspan="5">Reserved (Setting prohibited)</td> </tr> </tbody> </table>						Base Clock	Clock Enable	TCLKA	TCLKB	TCLKC	000	TIOCA1	TIOCA2	Base clock written in the left column	Pin input	Pin input	001	TIOCA0   TIOCC0	TIOCA1	Pin input	Base clock written in the left column	Pin input	010	TIOCA0	TIOCA1 & TIOCA2	Pin input	Base clock written in the left column	Pin input	011	TIOCA0   TIOCC0	TIOCA1 & TIOCA2	Pin input	Base clock written in the left column	Pin input	1xx	Reserved (Setting prohibited)				
	Base Clock	Clock Enable	TCLKA	TCLKB	TCLKC																																			
000	TIOCA1	TIOCA2	Base clock written in the left column	Pin input	Pin input																																			
001	TIOCA0   TIOCC0	TIOCA1	Pin input	Base clock written in the left column	Pin input																																			
010	TIOCA0	TIOCA1 & TIOCA2	Pin input	Base clock written in the left column	Pin input																																			
011	TIOCA0   TIOCC0	TIOCA1 & TIOCA2	Pin input	Base clock written in the left column	Pin input																																			
1xx	Reserved (Setting prohibited)																																							

Legend:

&: AND (logical multiplication)

| : OR (logical addition)

Note: The functions of bits 6 to 4 are not supported by the E6000 emulator. Figure 12.4 shows the setting examples.



Bit	Bit Name	Initial Value	R/W	Description
3	ABCS	0	R/W	<p>Asynchronous Base Clock Select</p> <p>Selects the 1-bit-interval base clock in asynchronous mode. The ABCS setting is valid in asynchronous mode (<math>C/\bar{A} = 0</math> in SMR).</p> <p>0: SCI_0 operates on base clock with frequency of 16 times transfer rate</p> <p>1: SCI_0 operates on base clock with frequency of 8 times transfer rate</p>
2	ACS2	0	R/W	Asynchronous Clock Source Select 2 to 0
1	ACS1	0	R/W	<p>These bits select the clock source in asynchronous mode depending on the combination with the bit 7 (ACS3) in SEMRB_0 (serial extended mode register B_0). When an average transfer rate is selected, the base clock is set automatically regardless of the ABCS value. Note that average transfer rates support only 10.667 MHz, 16 MHz, and 24 MHz, and not support other operating frequencies. Set ACS3 to ACS0 when inputting the external clock (the CKE1 bit in the SCR register is 1) in asynchronous mode (the <math>C/\bar{A}</math> bit in the SMR register is 0). Figures 12.3 and 12.4 show the setting examples.</p> <p>ACS 3210</p> <p>0000: External clock input</p> <p>0001: 115.152 kbps average transfer rate (for <math>\phi = 10.667</math> MHz only) is selected (SCI_0 operates on base clock with frequency of 16 times transfer rate)</p> <p>0010: 460.606 kbps average transfer rate (for <math>\phi = 10.667</math> MHz only) is selected (SCI_0 operates on base clock with frequency of eight times transfer rate)</p> <p>0011: 921.569 kbps average transfer rate (for <math>\phi = 16</math> MHz only) is selected (SCI_0 operates on base clock with frequency of eight times transfer rate)</p> <p>0100: TPU clock input</p> <p>The signal generated by TIOCA0, TIOCC0, TIOCA1, and TIOCA2, which are the compare match outputs for TPU_0 to TPU_2 or PWM outputs, is used as a base clock. Note that <math>\bar{I}RQ0</math> and <math>\bar{I}RQ1</math> cannot be used since TIOCA1 and TIOCA2 are used as outputs.</p>
0	ACS0	0	R/W	

Bit	Bit Name	Initial Value	R/W	Description
2	ACS2	0	R/W	0101: 115.196 kbps average transfer rate (for $\phi = 16$ MHz only) is selected (SCI_0 operates on base clock with frequency of 16 times transfer rate)
1	ACS1	0	R/W	
0	ACS0	0	R/W	0110: 460.784 kbps average transfer rate (for $\phi = 16$ MHz only) is selected (SCI_0 operates on base clock with frequency of eight times transfer rate)
				0111: 720 kbps average transfer rate (for $\phi = 16$ MHz only) is selected (SCI_0 operates on base clock with frequency of eight times transfer rate)
				1000: 115.132 kbps average transfer rate (for $\phi = 24$ MHz only) is selected* (SCI_0 operates on base clock with frequency of 16 times transfer rate)
				1001: 460.526 kbps average transfer rate (for $\phi = 24$ MHz only) is selected* (SCI_0 operates on base clock with frequency of 16 times transfer rate)
				1010: 720 kbps average transfer rate (for $\phi = 24$ MHz only) is selected* (SCI_0 operates on base clock with frequency of eight times transfer rate)
				1011: 921.053 kbps average transfer rate (for $\phi = 24$ MHz only) is selected* (SCI_0 operates on base clock with frequency of eight times transfer rate)
				11 $\times$ $\times$ : Reserved (Setting prohibited)

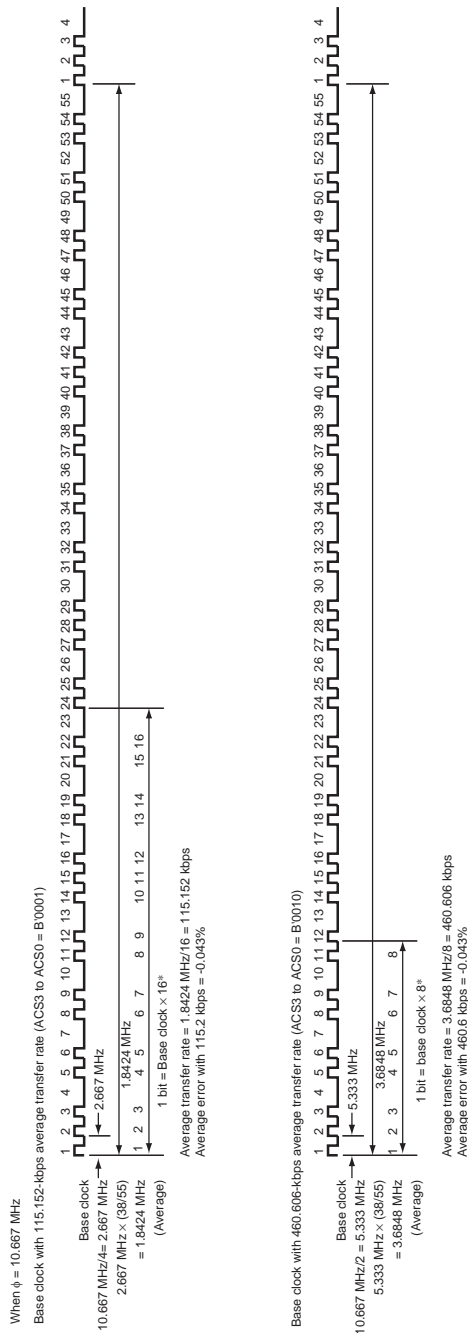
Note: \* The average transfer rate select functions for 24 MHz only (ACS3 to ACS0 = B'10XX) are not supported by the E6000 emulator.

### 12.3.10 Serial Extended Mode Register B\_0 (SEMRB\_0)

SEMRB\_0 enables clock source selection with the combination of SEMRA\_0, automatic transfer rate setting, and control of port 1 pins (P16, P14, P12, and P10) at the transfer clock generation by TPU.

Note: SEMRB\_0 is not supported by the E6000 emulator.

Bit	Bit Name	Initial Value	R/W	Description
7	ACS3	0	R/W	Asynchronous Clock Source Select Selects the clock source in asynchronous mode depending on the combination with the ACS2 to ACS0 (bits 2 to 0 in SEMRA_0). For details, see section 12.3.9, Serial Extended Mode Register A_0 (SEMRA_0).
6 to 4	—	Undefined	—	Reserved The write value should always be 0.
3	TIOCA2E	1	R/W	TIOCA2 Output Enable Controls the TIOCA2 output on the P16 pin. When the TIOCA2 in TPU is output to generate the transfer clock, P16 is used as other function pin by setting this bit to 0. 0: Disables output of TIOCA2 in TPU 1: Enables output of TIOCA2 in TPU
2	TIOCA1E	1	R/W	TIOCA1 Output Enable Controls the TIOCA1 output on the P14 pin. When the TIOCA1 in TPU is output to generate the transfer clock, P14 is used as other function pin by setting this bit to 0. 0: Disables output of TIOCA1 in TPU 1: Enables output TIOCA1 in TPU
1	TIOCC0E	1	R/W	TIOCC0 Output Enable Controls the TIOCC0 output on the P12 pin. When the TIOCC0 in TPU is output to generate the transfer clock, P12 is used as other function pin by setting this bit to 0. 0: Disables output of TIOCC0 in TPU 1: Enables output of TIOCC0 in TPU
0	TIOCA0E	1	R/W	TIOCA0 Output Enable Controls the TIOCA0 output on the P10 pin. When the TIOCA0 in TPU is output to generate the transfer clock, P10 is used as other function pin by setting this bit to 0. 0: Disables output of TIOCA0 in TPU 1: Enables output of TIOCA0 in TPU



Note: \* The length of one bit varies according to the base clock synchronization.

Figure 12.3 Examples of Base Clock when Average Transfer Rate Is Selected (1)

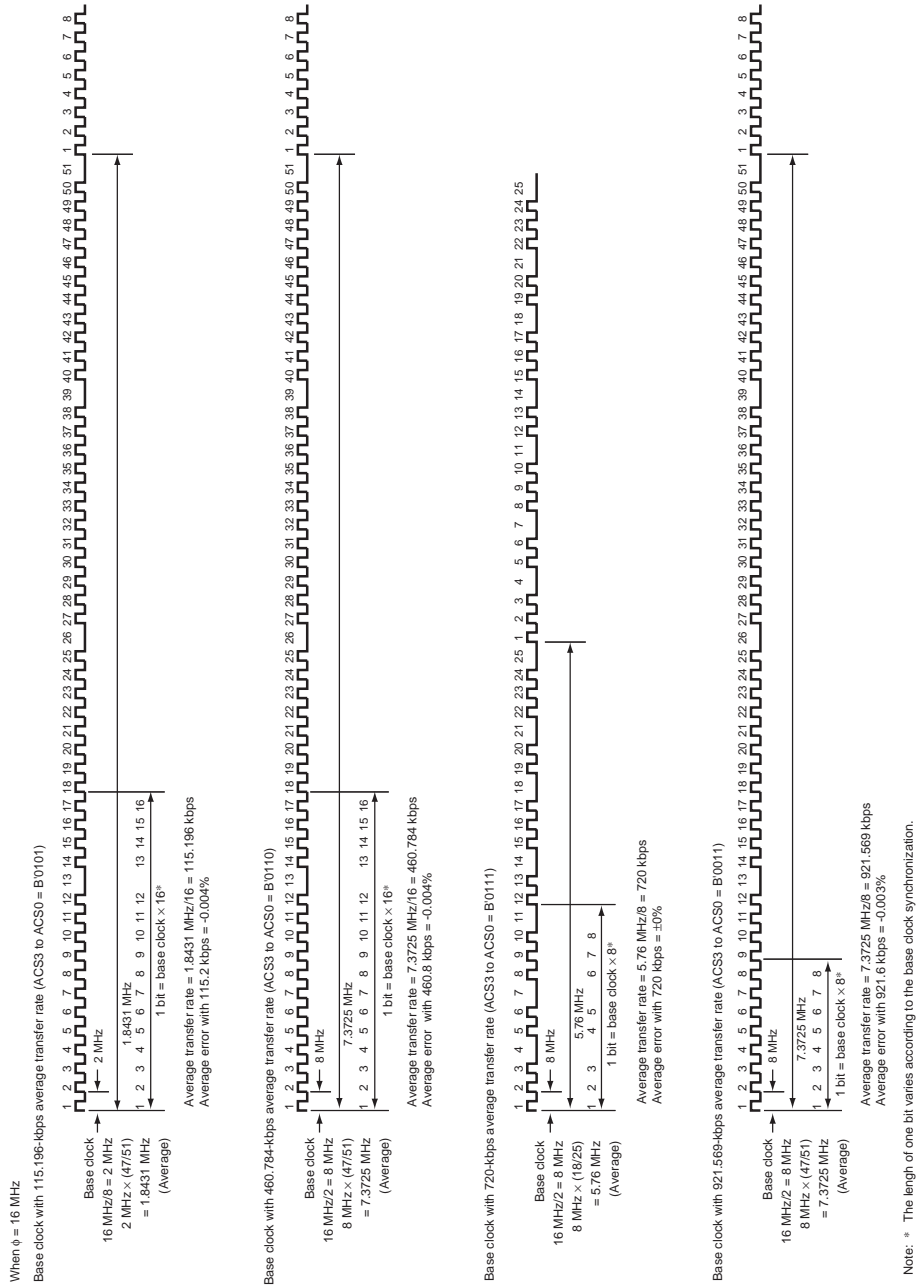


Figure 12.3 Examples of Base Clock when Average Transfer Rate Is Selected (2)

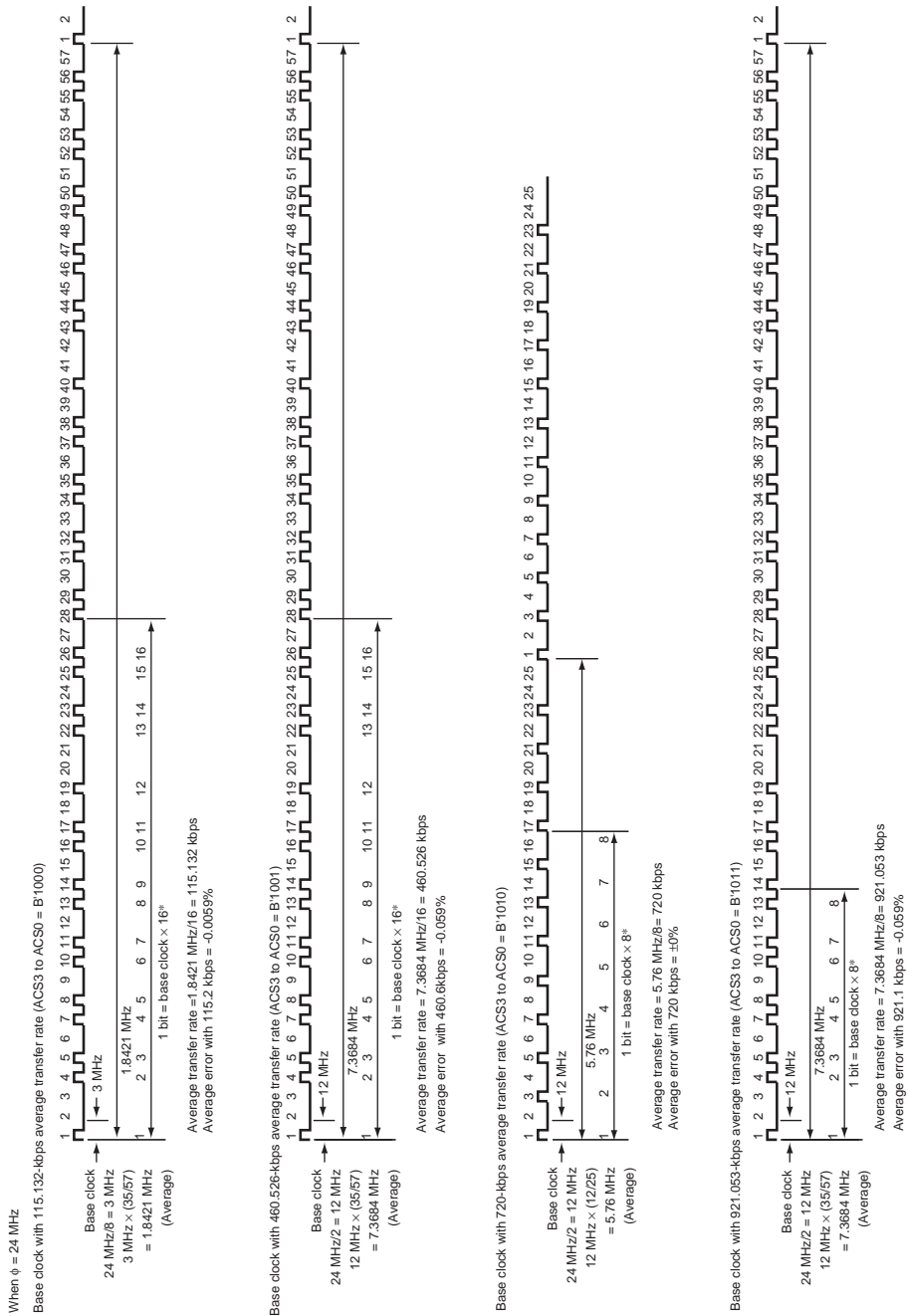


Figure 12.3 Examples of Base Clock when Average Transfer Rate Is Selected (3)

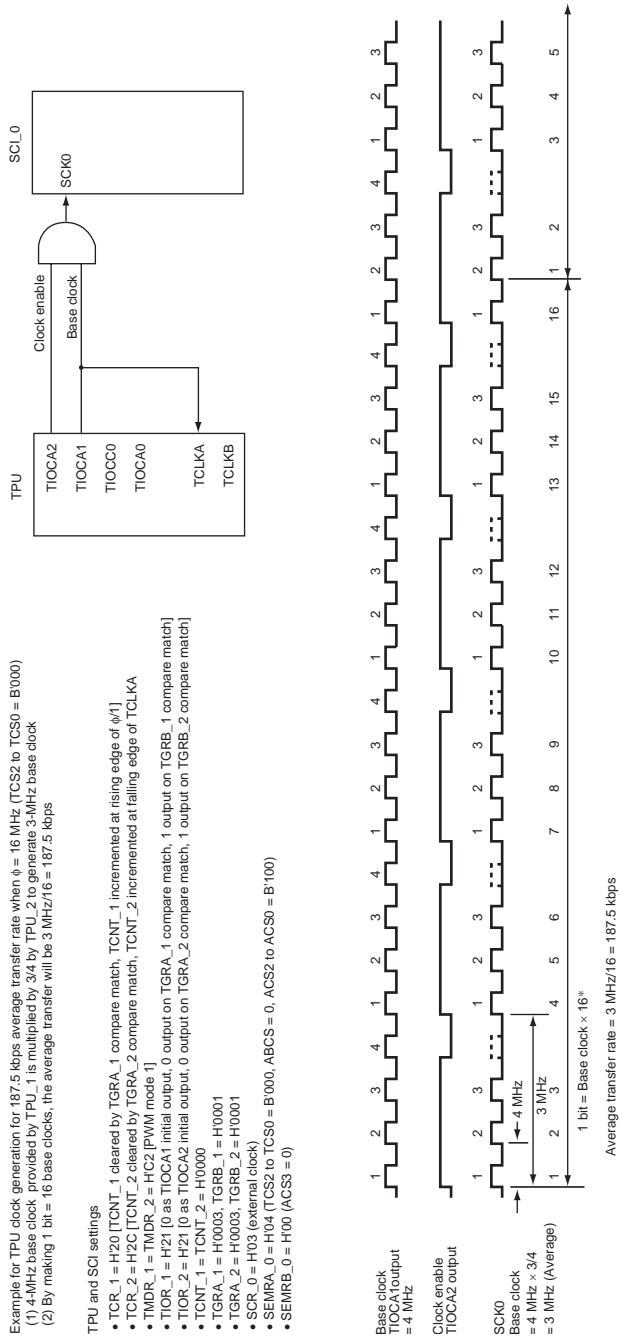


Figure 12.4 Example of Average Transfer Rate Setting when TPU Clock Is Input (1)

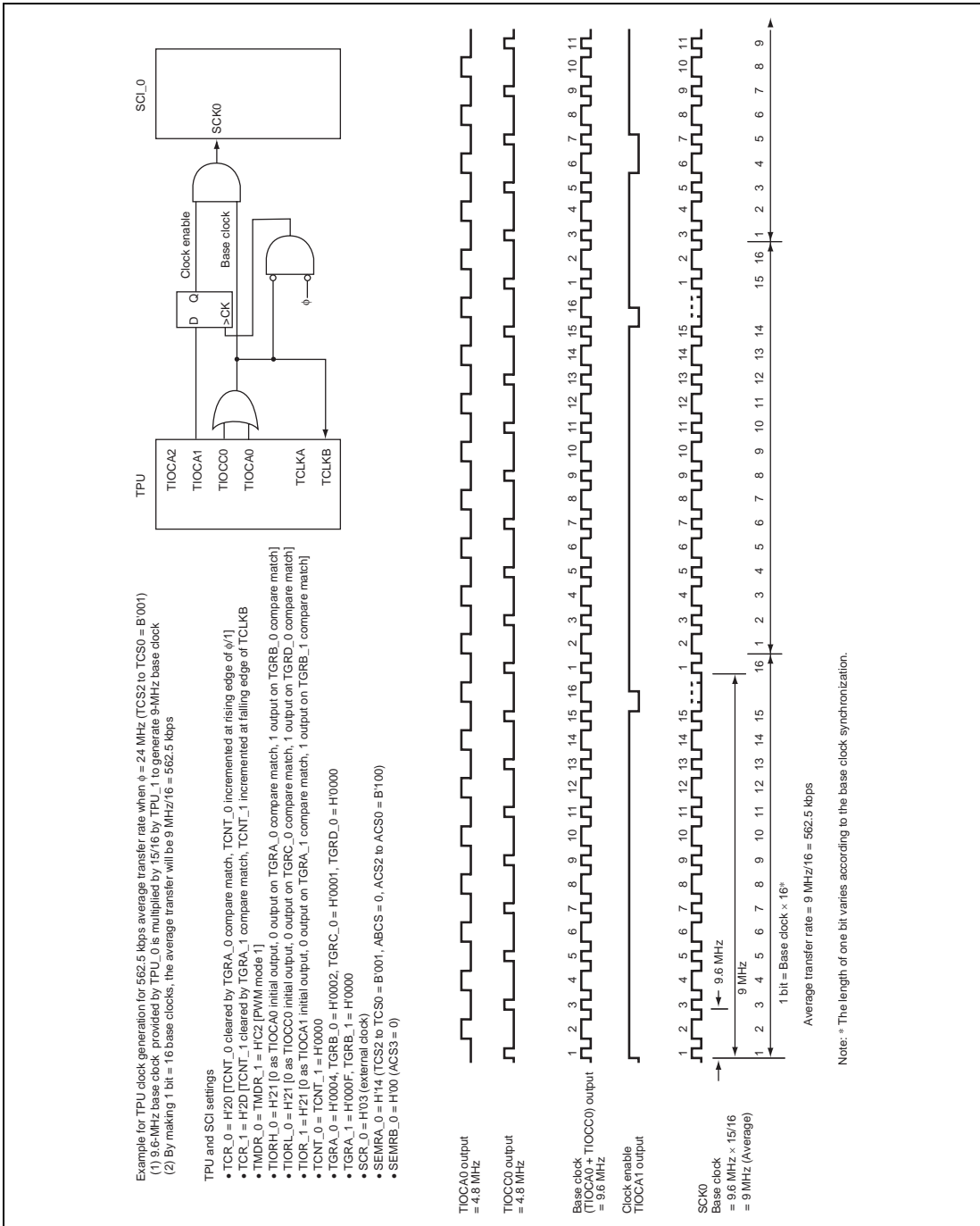


Figure 12.4 Example of Average Transfer Rate Setting when TPU Clock Is Input (2)



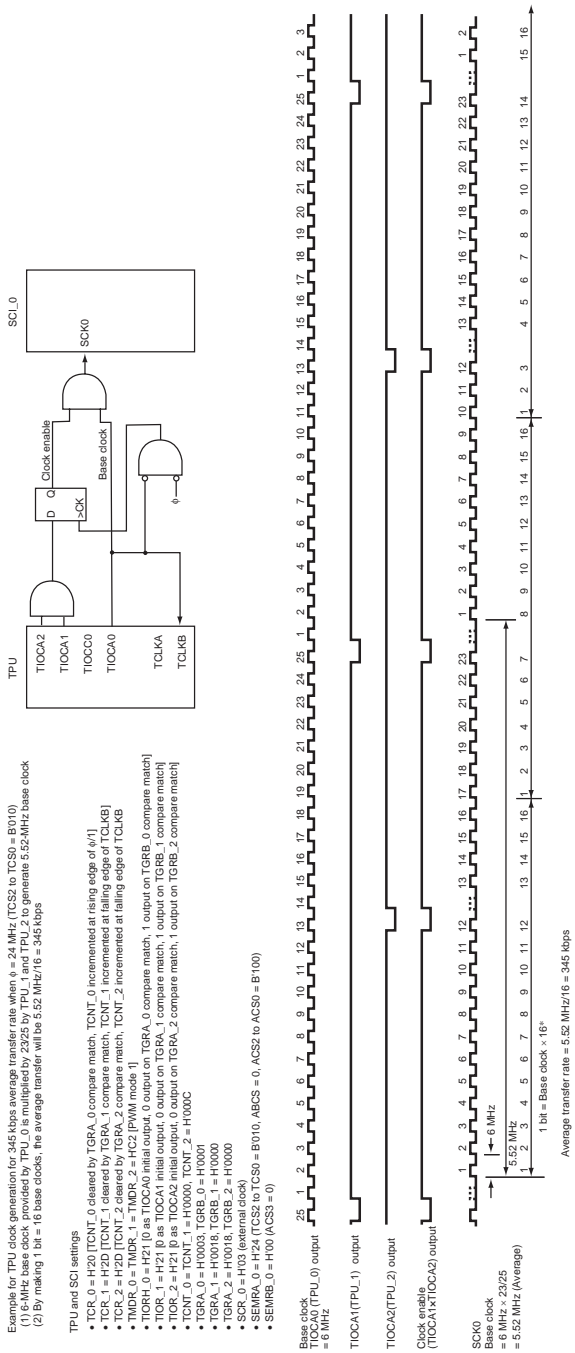


Figure 12.4 Example of Average Transfer Rate Setting when TPU Clock Is Input (3)

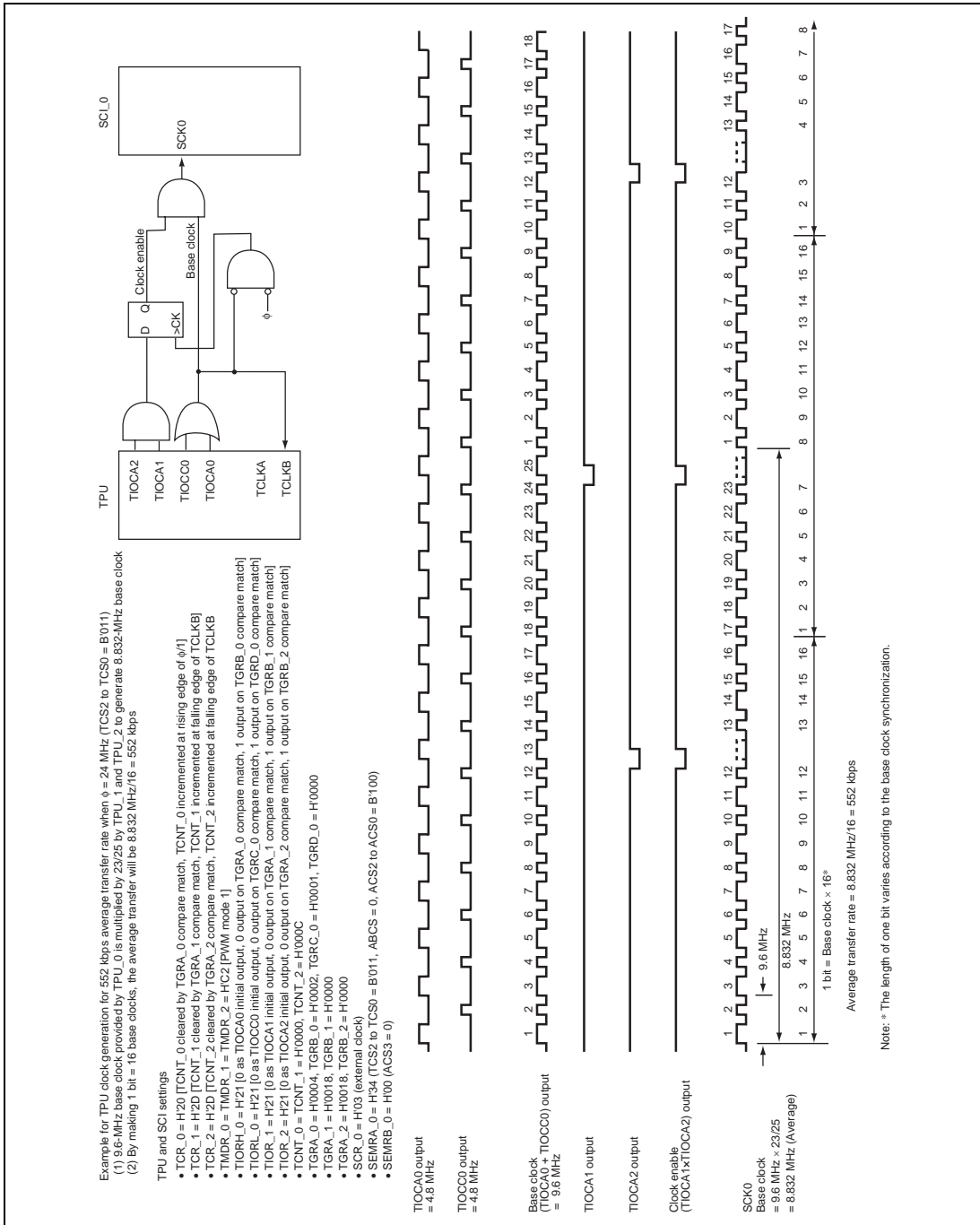


Figure 12.4 Example of Average Transfer Rate Setting when TPU Clock Is Input (4)

### 12.3.11 Bit Rate Register (BRR)

BRR is an 8-bit register that adjusts the bit rate. As the SCI performs baud rate generator control independently for each channel, different bit rates can be set for each channel. Table 12.2 shows the relationships between the N setting in BRR and bit rate B for normal asynchronous mode, clocked synchronous mode, and Smart Card interface mode. The initial value of BRR is H'FF, and it can be read from or written to by the CPU at all times.

**Table 12.2 Relationships between the N Setting in BRR and Bit Rate B**

Mode	ABCS	Bit Rate	Error
Asynchronous mode	0	$B = \frac{\phi \times 10^6}{64 \times 2^{2n-1} \times (N + 1)}$	Error (%) = $\left\{ \frac{\phi \times 10^6}{B \times 64 \times 2^{2n-1} \times (N + 1)} - 1 \right\} \times 100$
	1	$B = \frac{\phi \times 10^6}{32 \times 2^{2n-1} \times (N + 1)}$	Error (%) = $\left\{ \frac{\phi \times 10^6}{B \times 32 \times 2^{2n-1} \times (N + 1)} - 1 \right\} \times 100$
Clocked synchronous mode	×	$B = \frac{\phi \times 10^6}{8 \times 2^{2n-1} \times (N + 1)}$	—
Smart Card interface mode	×	$B = \frac{\phi \times 10^6}{S \times 2^{2n+1} \times (N + 1)}$	Error (%) = $\left\{ \frac{\phi \times 10^6}{B \times S \times 2^{2n+1} \times (N + 1)} - 1 \right\} \times 100$

Legend:

B: Bit rate (bps)

N: BRR setting for baud rate generator ( $0 \leq N \leq 255$ )

$\phi$ : Operating frequency (MHz)

n, S: Determined by the SMR settings shown in the following tables.

×: Don't care

SMR Setting				SMR Setting		
CKS1	CKS0	Clock Source	n	BCP1	BCP0	S
0	0	$\phi$	0	0	0	32
0	1	$\phi/4$	1	0	1	64
1	0	$\phi/16$	2	1	0	372
1	1	$\phi/64$	3	1	1	256

Table 12.3 shows sample N settings in BRR in normal asynchronous mode. Table 12.4 shows the maximum bit rate for each frequency in normal asynchronous mode. Table 12.6 shows sample N settings in BRR in clocked synchronous mode. Table 12.8 shows sample N settings in BRR in Smart Card interface mode. In Smart Card interface mode, S (the number of basic clock periods in a 1-bit transfer interval) can be selected. For details, see section 12.7.5, Receive Data Sampling

Timing and Reception Margin. Tables 12.5 and 12.7 show the maximum bit rates with external clock input.

When the ABCS bit in SCI\_0's serial extended mode register A\_0 (SEMRA\_0) is set to 1 in asynchronous mode, the maximum bit rates are twice those shown in table 12.3.

**Table 12.3 BRR Settings for Various Bit Rates (Asynchronous Mode)**

Bit Rate (bps)	Operating Frequency $\phi$ (MHz)											
	2			2.097152			2.4576			3		
	n	N	Error (%)	n	N	Error (%)	n	N	Error (%)	n	N	Error (%)
110	1	141	0.03	1	148	-0.04	1	174	-0.26	1	212	0.03
150	1	103	0.16	1	108	0.21	1	127	0.00	1	155	0.16
300	0	207	0.16	0	217	0.21	0	255	0.00	1	77	0.16
600	0	103	0.16	0	108	0.21	0	127	0.00	0	155	0.16
1200	0	51	0.16	0	54	-0.70	0	63	0.00	0	77	0.16
2400	0	25	0.16	0	26	1.14	0	31	0.00	0	38	0.16
4800	0	12	0.16	0	13	-2.48	0	15	0.00	0	19	-2.34
9600	—	—	—	0	6	-2.48	0	7	0.00	0	9	-2.34
19200	—	—	—	—	—	—	0	3	0.00	0	4	-2.34
31250	0	1	0.00	—	—	—	—	—	—	0	2	0.00
38400	—	—	—	—	—	—	0	1	0.00	—	—	—

Bit Rate (bps)	Operating Frequency $\phi$ (MHz)											
	3.6864			4			4.9152			5		
	n	N	Error (%)	n	N	Error (%)	n	N	Error (%)	n	N	Error (%)
110	2	64	0.70	2	70	0.03	2	86	0.31	2	88	-0.25
150	1	191	0.00	1	207	0.16	1	255	0.00	2	64	0.16
300	1	95	0.00	1	103	0.16	1	127	0.00	1	129	0.16
600	0	191	0.00	0	207	0.16	0	255	0.00	1	64	0.16
1200	0	95	0.00	0	103	0.16	0	127	0.00	0	129	0.16
2400	0	47	0.00	0	51	0.16	0	63	0.00	0	64	0.16
4800	0	23	0.00	0	25	0.16	0	31	0.00	0	32	-1.36
9600	0	11	0.00	0	12	0.16	0	15	0.00	0	15	1.73
19200	0	5	0.00	—	—	—	0	7	0.00	0	7	1.73
31250	—	—	—	0	3	0.00	0	4	-1.70	0	4	0.00
38400	0	2	0.00	—	—	—	0	3	0.00	0	3	1.73

Bit Rate (bps)	Operating Frequency $\phi$ (MHz)											
	6			6.144			7.3728			8		
	n	N	Error (%)	n	N	Error (%)	n	N	Error (%)	n	N	Error (%)
110	2	106	-0.44	2	108	0.08	2	130	-0.07	2	141	0.03
150	2	77	0.16	2	79	0.00	2	95	0.00	2	103	0.16
300	1	155	0.16	1	159	0.00	1	191	0.00	1	207	0.16
600	1	77	0.16	1	79	0.00	1	95	0.00	1	103	0.16
1200	0	155	0.16	0	159	0.00	0	191	0.00	0	207	0.16
2400	0	77	0.16	0	79	0.00	0	95	0.00	0	103	0.16
4800	0	38	0.16	0	39	0.00	0	47	0.00	0	51	0.16
9600	0	19	-2.34	0	19	0.00	0	23	0.00	0	25	0.16
19200	0	9	-2.34	0	9	0.00	0	11	0.00	0	12	0.16
31250	0	5	0.00	0	5	2.40	—	—	—	0	7	0.00
38400	0	4	-2.34	0	4	0.00	0	5	0.00	—	—	—

Bit Rate (bps)	Operating Frequency $\phi$ (MHz)											
	9.8304			10			12			12.288		
	n	N	Error (%)	n	N	Error (%)	n	N	Error (%)	n	N	Error (%)
110	2	174	-0.26	2	177	-0.25	2	212	0.03	2	217	0.08
150	2	127	0.00	2	129	0.16	2	155	0.16	2	159	0.00
300	1	255	0.00	2	64	0.16	2	77	0.16	2	79	0.00
600	1	127	0.00	1	129	0.16	1	155	0.16	1	159	0.00
1200	0	255	0.00	1	64	0.16	1	77	0.16	1	79	0.00
2400	0	127	0.00	0	129	0.16	0	155	0.16	0	159	0.00
4800	0	63	0.00	0	64	0.16	0	77	0.16	0	79	0.00
9600	0	31	0.00	0	32	-1.36	0	38	0.16	0	39	0.00
19200	0	15	0.00	0	15	1.73	0	19	-2.34	0	19	0.00
31250	0	9	-1.70	0	9	0.00	0	11	0.00	0	11	2.40
38400	0	7	0.00	0	7	1.73	0	9	-2.34	0	9	0.00

Bit Rate (bps)	Operating Frequency $\phi$ (MHz)											
	14			14.7456			16			17.2032		
	n	N	Error (%)	n	N	Error (%)	n	N	Error (%)	n	N	Error (%)
110	2	248	-0.17	3	64	0.70	3	70	0.03	3	75	0.48
150	2	181	0.16	2	191	0.00	2	207	0.16	2	223	0.00
300	2	90	0.16	2	95	0.00	2	103	0.16	2	111	0.00
600	1	181	0.16	1	191	0.00	1	207	0.16	1	223	0.00
1200	1	90	0.16	1	95	0.00	1	103	0.16	1	111	0.00
2400	0	181	0.16	0	191	0.00	0	207	0.16	0	223	0.00
4800	0	90	0.16	0	95	0.00	0	103	0.16	0	111	0.00
9600	0	45	-0.93	0	47	0.00	0	51	0.16	0	55	0.00
19200	0	22	-0.93	0	23	0.00	0	25	0.16	0	27	0.00
31250	0	13	0.00	0	14	-1.70	0	15	0.00	0	16	1.20
38400	-	-	-	0	11	0.00	0	12	0.16	0	13	0.00

Bit Rate (bps)	Operating Frequency $\phi$ (MHz)											
	18			19.6608			20			24		
	n	N	Error (%)	n	N	Error (%)	n	N	Error (%)	n	N	Error (%)
110	3	79	-0.12	3	86	0.31	3	88	-0.25	3	106	-0.44
150	2	233	0.16	2	255	0.00	3	64	0.16	3	77	0.16
300	2	116	0.16	2	127	0.00	2	129	0.16	2	155	0.16
600	1	233	0.16	1	255	0.00	2	64	0.16	2	77	0.16
1200	1	116	0.16	1	127	0.00	1	129	0.16	1	155	0.16
2400	0	233	0.16	0	255	0.00	1	64	0.16	1	77	0.16
4800	0	116	0.16	0	127	0.00	0	129	0.16	0	155	0.16
9600	0	58	-0.69	0	63	0.00	0	64	0.16	0	77	0.16
19200	0	28	1.02	0	31	0.00	0	32	-1.36	0	38	0.16
31250	0	17	0.00	0	19	-1.70	0	19	0.00	0	23	0.00
38400	0	14	-2.34	0	15	0.00	0	15	1.73	0	19	-2.34

Note: This table shows bit rates when the ABCS bit in SEMRA\_0 is cleared to 0.

When the ABCS bit in SEMR0 is set to 1, the bit rates are twice those shown in this table.

In this LSI, operating frequency  $\phi$  must be 6 MHz or greater.

**Table 12.4 Maximum Bit Rate for Each Frequency (Asynchronous Mode)**

$\phi$ (MHz)	Maximum Bit Rate (kbps)				$\phi$ (MHz)	Maximum Bit Rate (kbps)			
	ABCS = 0	ABCS = 1	n	N		ABCS = 0	ABCS = 1	n	N
2	62.5	125.0	0	0	9.8304	307.2	614.4	0	0
2.097152	65.536	131.027	0	0	10	312.5	625.0	0	0
2.4576	76.8	153.6	0	0	12	375.0	750.0	0	0
3	93.75	187.5	0	0	12.288	384.0	768.0	0	0
3.6864	115.2	230.4	0	0	14	437.5	875.0	0	0
4	125.0	250.0	0	0	14.7456	460.8	921.6	0	0
4.9152	153.6	307.2	0	0	16	500.0	1000.0	0	0
5	156.25	312.5	0	0	17.2032	537.6	1075.2	0	0
6	187.5	375.0	0	0	18	562.5	1125.0	0	0
6.144	192.0	384.0	0	0	19.6608	614.4	1228.8	0	0
7.3728	230.4	460.8	0	0	20	625.0	1250.0	0	0
8	250.0	500.0	0	0	24	750.0	1500.0	0	0

Table 12.5 Maximum Bit Rate with External Clock Input (Asynchronous Mode)

$\phi$ (MHz)	External Input Clock (MHz)	Maximum Bit Rate (kbps)		$\phi$ (MHz)	External Input Clock (MHz)	Maximum Bit Rate (kbps)	
		ABCS = 0	ABCS = 1			ABCS = 0	ABCS = 1
2	0.5000	31.25	62.5	9.8304	2.4576	153.6	307.2
2.097152	0.5243	327.68	65.536	10	2.5000	156.25	312.5
2.4576	0.6144	38.4	76.8	12	3.0000	187.5	375.0
3	0.7500	46.875	93.75	12.288	3.0720	192.0	384.0
3.6864	0.9216	57.6	115.2	14	3.5000	218.75	437.0
4	1.0000	62.5	125.0	14.7456	3.6864	230.4	460.8
4.9152	1.2288	76.8	153.6	16	4.0000	250.0	500.0
5	1.2500	78.125	156.25	17.2032	4.3008	268.8	537.6
6	1.5000	93.75	187.5	18	4.5000	281.25	562.5
6.144	1.5360	96.0	192.0	19.6608	4.9152	307.2	614.4
7.3728	1.8432	115.2	230.4	20	5.0000	312.5	625.0
8	2.0000	125.0	250.0	24	6.0000	375.0	750.0

Note: In this LSI, operating frequency  $\phi$  must be 6 MHz or greater.



**Table 12.6 BRR Settings for Various Bit Rates (Clocked Synchronous Mode)**

Bit Rate (bps)	Operating Frequency $\phi$ (MHz)															
	2		4		6		8		10		16		20		24	
	n	N	n	N	n	N	n	N	n	N	n	N	n	N	n	N
110	3	70	—	—												
250	2	124	2	249			3	124	—	—	3	249				
500	1	249	2	124			2	249	—	—	3	124	—	—	—	—
1 k	1	124	1	249			2	124	—	—	2	249	—	—	—	—
2.5 k	0	199	1	99	1	149	1	199	1	249	2	99	2	124	2	149
5 k	0	99	0	199	1	74	1	99	1	124	1	199	1	249	2	74
10 k	0	49	0	99	0	149	0	199	0	249	1	99	1	124	1	149
25 k	0	19	0	39	0	59	0	79	0	99	0	159	0	199	0	239
50 k	0	9	0	19	0	29	0	39	0	49	0	79	0	99	0	119
100 k	0	4	0	9	0	14	0	19	0	24	0	39	0	49	0	59
250 k	0	1	0	3	0	5	0	7	0	9	0	15	0	19	0	23
500 k	0	0*	0	1	0	2	0	3	0	4	0	7	0	9	0	11
1 M			0	0*			0	1			0	3	0	4	0	5
2 M							0	0*			0	1			0	2
2.5 M									0	0*			0	1		
4 M											0	0*				
5 M													0	0*		
6 M															0	0*

Legend:

Blank: Cannot be set.

—: Can be set, but there will be a degree of error.

\*: Continuous transfer is not possible.

**Table 12.7 Maximum Bit Rate with External Clock Input (Clocked Synchronous Mode)**

$\phi$ (MHz)	External Input Clock (MHz)	Maximum Bit Rate (Mbps)	$\phi$ (MHz)	External Input Clock (MHz)	Maximum Bit Rate (Mbps)
2	0.333	0.333	14	2.333	2.333
4	0.667	0.667	16	2.667	2.667
6	1.000	1.000	18	3.000	3.000
8	1.333	1.333	20	3.333	3.333
10	1.667	1.667	24	4.000	4.000
12	2.000	2.000			

Note: In this LSI, operating frequency  $\phi$  must be 6 MHz or greater.

**Table 12.8 BRR Settings for Various Bit Rates**  
(Smart Card Interface Mode, when  $n = 0$  and  $S = 372$ )

Bit Rate (bps)	Operating Frequency $\phi$ (MHz)											
	5.00		7.00		7.1424		10.00		10.7136		13.00	
	N	Error (%)	N	Error (%)	N	Error (%)	N	Error (%)	N	Error (%)	N	Error (%)
6720	0	0.01	1	30.00	1	28.57	1	0.01	1	7.14	2	13.33
9600	0	30.00	0	1.99	0	0.00	1	30.00	1	25.00	1	8.99

Bit Rate (bps)	Operating Frequency $\phi$ (MHz)									
	14.2848		16.00		18.00		20.00		24.00	
	N	Error (%)	N	Error (%)	N	Error (%)	N	Error (%)	N	Error (%)
6720	2	4.76	2	6.67	3	0.01	3	0.01	4	3.99
9600	1	0.00	1	12.01	2	15.99	2	6.66	2	12.01

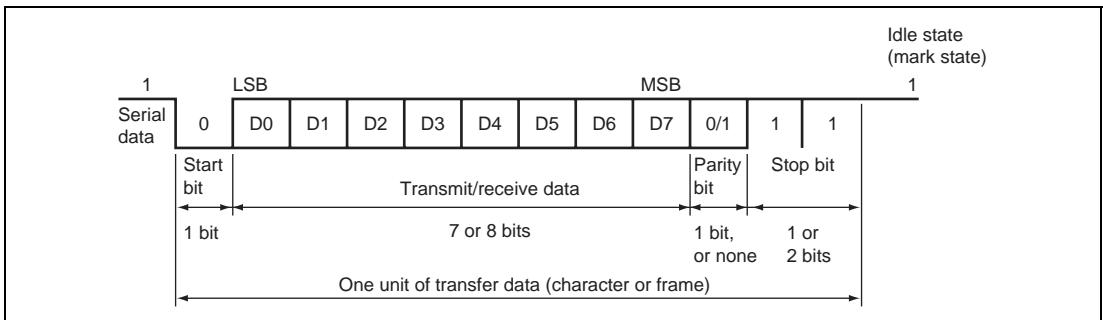
**Table 12.9 Maximum Bit Rate at Various Frequencies (Smart Card Interface Mode)**

$\phi$ (MHz)	Maximum Bit Rate (bps)					n	N
	S = 32	S = 64	S = 256	S = 372			
5.00	78125	39063	9766	6720		0	0
6.00	93750	46875	11719	8065		0	0
7.00	109375	54688	13672	9409		0	0
7.1424	111600	55800	13950	9600		0	0
10.00	156250	78125	19531	13441		0	0
10.7136	167400	83700	20925	14400		0	0
13.00	203125	101563	25391	17473		0	0
14.2848	223200	111600	27900	19200		0	0
16.00	250000	125000	31250	21505		0	0
18.00	281250	140625	35156	24194		0	0
20.00	312500	156250	39063	26882		0	0
24.00	375000	187500	46875	32258		0	0

Note: In this LSI, operating frequency  $\phi$  must be 6 MHz or greater.

## 12.4 Operation in Asynchronous Mode

Figure 12.5 shows the general format for asynchronous serial communication. One frame consists of a start bit (low level), followed by data (in LSB-first order), a parity bit (high or low level), and finally stop bits (high level). In asynchronous serial communication, the transmission line is usually held in the mark state (high level). The SCI monitors the transmission line. When the transmission line goes to the space state (low level), the SCI recognizes a start bit and starts serial communication. Inside the SCI, the transmitter and receiver are independent units, enabling full-duplex. Both the transmitter and the receiver also have a double-buffered structure, so data can be read from or written during transmission or reception, enabling continuous data transfer.



**Figure 12.5 Data Format in Asynchronous Communication  
(Example with 8-Bit Data, Parity, Two Stop Bits)**

### 12.4.1 Data Transfer Format

Table 12.10 shows the data transfer formats that can be used in asynchronous mode. Any of 12 transfer formats can be selected according to the SMR setting. For details on the multiprocessor bit, refer to section 12.5, Multiprocessor Communication Function.

**Table 12.10 Serial Transfer Formats (Asynchronous Mode)**

SMR Settings				Serial Transfer Format and Frame Length												
CHR	PE	MP	STOP	1	2	3	4	5	6	7	8	9	10	11	12	
0	0	0	0	S	8-bit data								STOP			
0	0	0	1	S	8-bit data								STOP	STOP		
0	1	0	0	S	8-bit data								P	STOP		
0	1	0	1	S	8-bit data								P	STOP	STOP	
1	0	0	0	S	7-bit data							STOP				
1	0	0	1	S	7-bit data							STOP	STOP			
1	1	0	0	S	7-bit data							P	STOP			
1	1	0	1	S	7-bit data							P	STOP	STOP		
0	–	1	0	S	8-bit data								MPB	STOP		
0	–	1	1	S	8-bit data								MPB	STOP	STOP	
1	–	1	0	S	7-bit data							MPB	STOP			
1	–	1	1	S	7-bit data							MPB	STOP	STOP		

Legend:

S: Start bit

STOP: Stop bit

P: Parity bit

MPB: Multiprocessor bit

### 12.4.2 Receive Data Sampling Timing and Reception Margin in Asynchronous Mode

In asynchronous mode, the SCI operates on a basic clock with a frequency of 16 times the transfer rate. In reception, the SCI samples the falling edge of the start bit using the basic clock, and performs internal synchronization. Receive data is latched internally at the rising edge of the 8th pulse of the basic clock as shown in Figure 12.6. Thus, the reception margin in asynchronous mode is given by formula (1) below.

$$M = \left| \left( 0.5 - \frac{1}{2N} \right) - (L - 0.5) F - \frac{|D - 0.5|}{N} (1 + F) \right| \times 100 \text{ [%]} \quad \dots \text{ Formula (1)}$$

Where M: Reception margin

N: Ratio of bit rate to clock ( $N = 16$  if  $ABCS = 0$ ,  $N = 8$  if  $ABCS = 1$ )

D: Clock duty ( $D = 0$  to  $1.0$ )

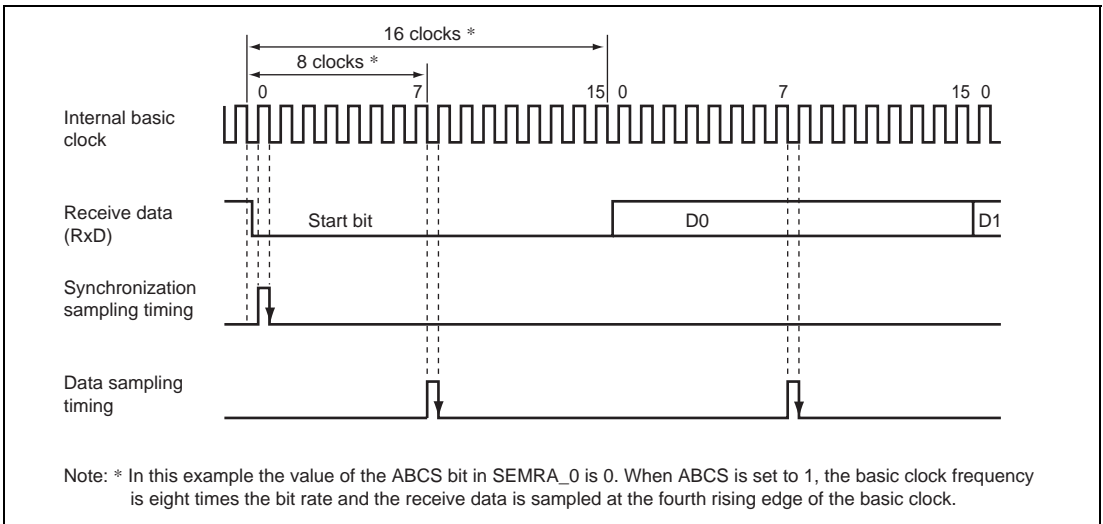
L: Frame length ( $L = 9$  to  $12$ )

F: Absolute value of clock rate deviation

Assuming values of F (absolute value of clock rate deviation) = 0, D (clock duty) = 0.5, and N (ratio of bit rate to clock) = 16 in formula (1), the reception margin can be given by the formula.

$$M = \{0.5 - 1/(2 \times 16)\} \times 100 \text{ [%]} = 46.875\%$$

However, this is only the computed value, and a margin of 20% to 30% should be allowed for in system design.



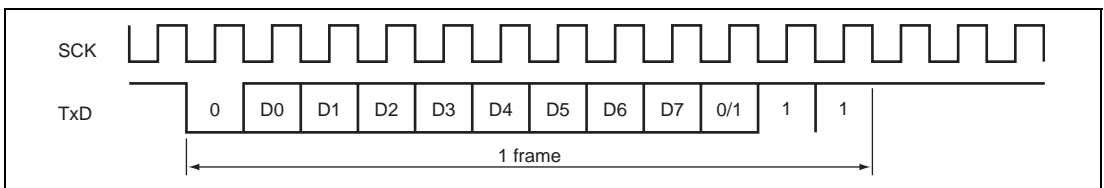
**Figure 12.6 Receive Data Sampling Timing in Asynchronous Mode**

Note: \* Figure 12.6 shows an example when the ABCS bit of SEMRA\_0 is cleared to 0. When ABCS is set to 1, the clock frequency of basic clock is 8 times the bit rate and the receive data is sampled at the rising edge of the 4th pulse of the basic clock.

### 12.4.3 Clock

Either an internal clock generated by the on-chip baud rate generator or an external clock input at the SCK pin can be selected as the SCI's serial clock, according to the setting of the  $C/\bar{A}$  bit in SMR and the CKE0 and CKE1 bits in SCR. When an external clock is input at the SCK pin, the clock frequency should be 16 times the bit rate used. When an external clock is selected, the basic clock of average transfer rate can be selected according to the ACS2 to ACS0 bit setting of SEMR\_0.

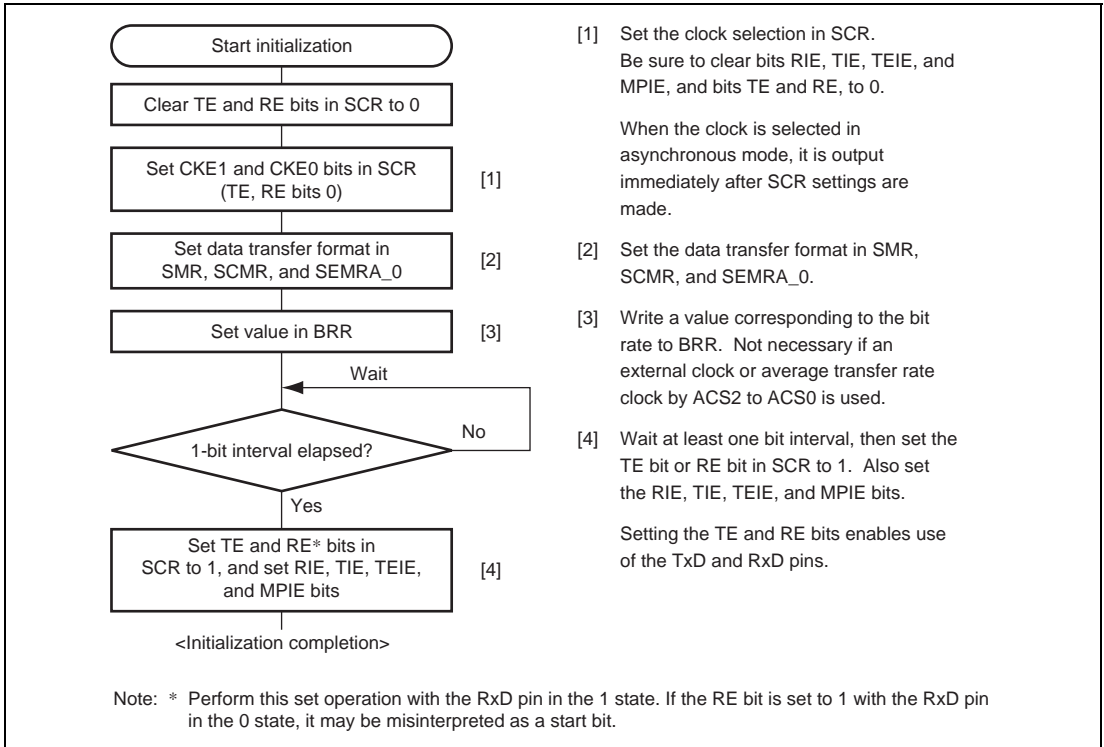
When the SCI is operated on an internal clock, the clock can be output from the SCK pin by setting CKE1 = 0 and CKE0 = 1. The frequency of the clock output in this case is equal to the bit rate, and the phase is such that the rising edge of the clock is in the middle of the transmit data, as shown in figure 12.7.



**Figure 12.7 Relationship between Output Clock and Transfer Data Phase (Asynchronous Mode)**

## 12.4.4 SCI Initialization (Asynchronous Mode)

Before transmitting and receiving data, you should first clear the TE and RE bits in SCR to 0, then initialize the SCI as described in a sample flowchart in figure 12.8. When the operating mode, or transfer format, is changed for example, the TE and RE bits must be cleared to 0 before making the change using the following procedure. When the TE bit is cleared to 0, the TDRE flag is set to 1. Note that clearing the RE bit to 0 does not initialize the contents of the RDRF, PER, FER, and ORER flags, or the contents of RDR. When the external clock is used in asynchronous mode, the clock must be supplied even during initialization.

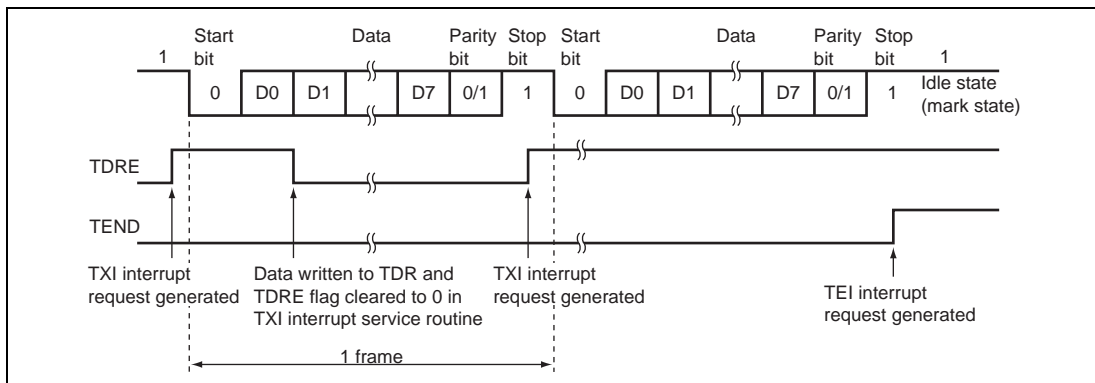


**Figure 12.8 Sample SCI Initialization Flowchart**

### 12.4.5 Data Transmission (Asynchronous Mode)

Figure 12.9 shows an example of operation for transmission in asynchronous mode. In transmission, the SCI operates as described below.

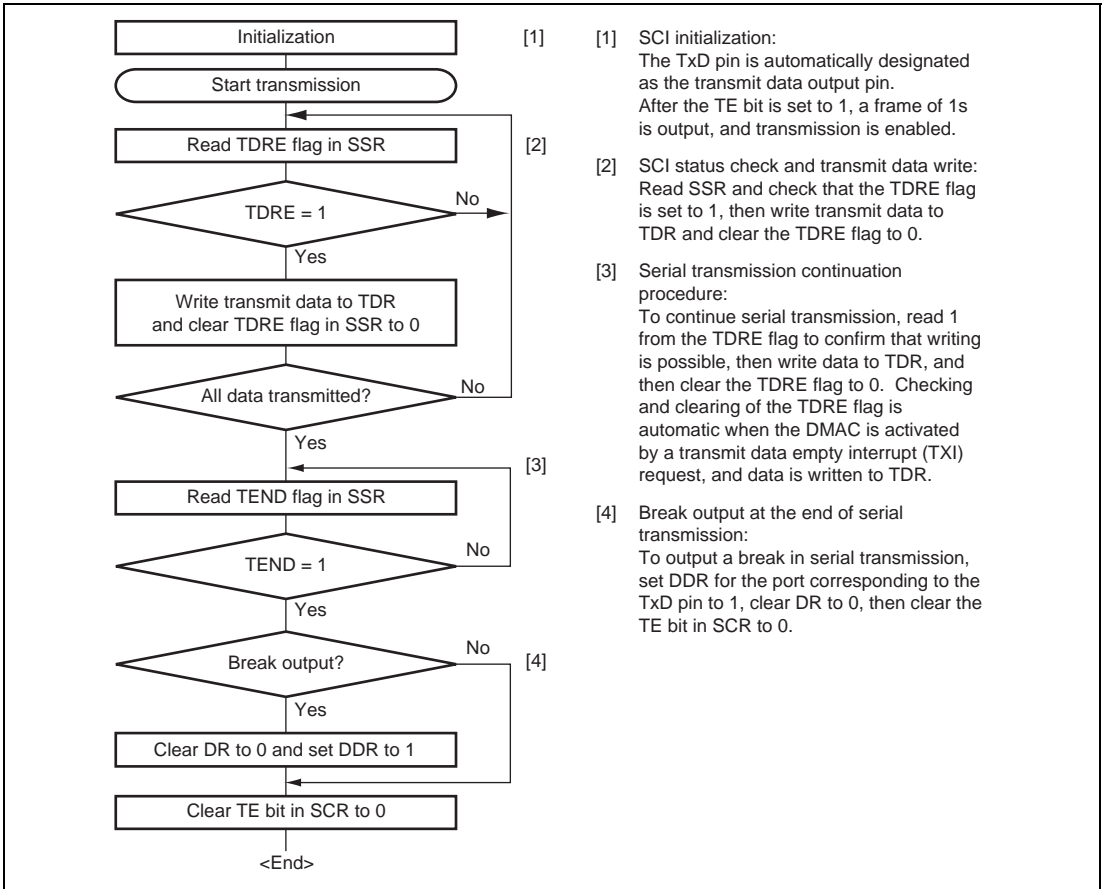
1. The SCI monitors the TDRE flag in SSR. If the flag is cleared to 0, the SCI recognizes that data has been written to TDR, and transfers the data from TDR to TSR.
2. After transferring data from TDR to TSR, the SCI sets the TDRE flag to 1 and starts transmission. If the TIE bit is set to 1 at this time, a transmit data empty interrupt request (TXI) is generated. Continuous transmission is possible because the TXI interrupt routine writes next transmit data to TDR before transmission of the current transmit data has been completed.
3. Data is sent from the TxD pin in the following order: start bit, transmit data, parity bit or multiprocessor bit (may be omitted depending on the format), and stop bit.
4. The SCI checks the TDRE flag at the timing for sending the stop bit.
5. If the TDRE flag is 0, the data is transferred from TDR to TSR, the stop bit is sent, and then serial transmission of the next frame is started.
6. If the TDRE flag is 1, the TEND flag in SSR is set to 1, the stop bit is sent, and then the "mark state" is entered, in which 1 is output. If the TEIE bit in SCR is set to 1 at this time, a TEI interrupt request is generated.



**Figure 12.9 Example of Operation in Transmission in Asynchronous Mode  
(Example with 8-Bit Data, Parity, One Stop Bit)**

Figure 12.10 shows a sample flowchart for transmission in asynchronous mode.



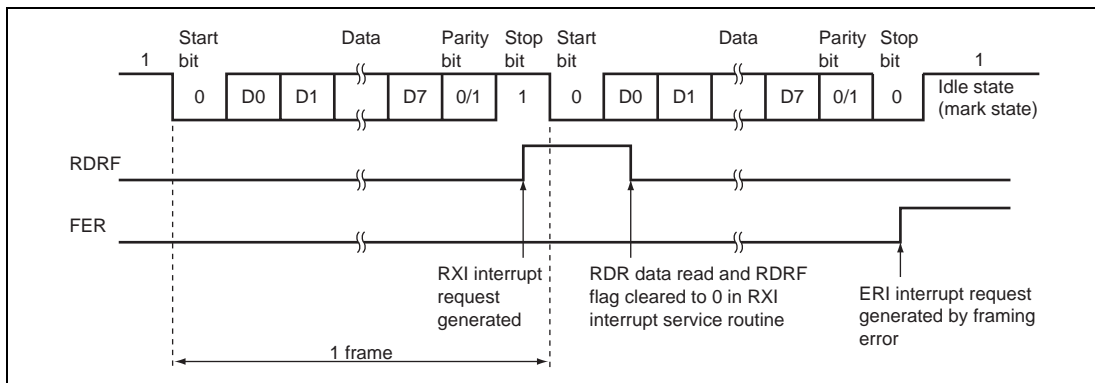


**Figure 12.10 Sample Serial Data Transmission Flowchart**

### 12.4.6 Serial Data Reception (Asynchronous Mode)

Figure 12.11 shows an example of operation for reception in asynchronous mode. In serial reception, the SCI operates as described below.

1. The SCI monitors the communication line. If a start bit is detected, the SCI performs internal synchronization, receives receive data in RSR, and checks the parity bit and stop bit.
2. If an overrun error occurs (when reception of the next data is completed while the RDRF flag is still set to 1), the ORER bit in SSR is set to 1. If the RIE bit in SCR is set to 1 at this time, an ERI interrupt request is generated. Receive data is not transferred to RDR. The RDRF flag remains to be set to 1.
3. If a parity error is detected, the PER bit in SSR is set to 1 and receive data is transferred to RDR. If the RIE bit in SCR is set to 1 at this time, an ERI interrupt request is generated.
4. If a framing error is detected (when the stop bit is 0), the FER bit in SSR is set to 1 and receive data is transferred to RDR. If the RIE bit in SCR is set to 1 at this time, an ERI interrupt request is generated.
5. If reception is completed successfully, the RDRF bit in SSR is set to 1, and receive data is transferred to RDR. If the RIE bit in SCR is set to 1 at this time, an RXI interrupt request is generated. Continuous reception is possible because the RXI interrupt routine reads the receive data transferred to RDR before reception of the next receive data has been completed.



**Figure 12.11 Example of SCI Operation in Reception  
(Example with 8-Bit Data, Parity, One Stop Bit)**

Table 12.11 shows the states of the SSR status flags and receive data handling when a receive error is detected. If a receive error is detected, the RDRF flag retains its state before receiving data. Reception cannot be resumed while a receive error flag is set to 1. Accordingly, clear the ORER, FER, PER, and RDRF bits to 0 before resuming reception. Figure 12.12 shows a sample flow chart for serial data reception.

Table 12.11 SSR Status Flags and Receive Data Handling

SSR Status Flag				Receive Data	Receive Error Type
RDRF*	ORER	FER	PER		
1	1	0	0	Lost	Overflow error
0	0	1	0	Transferred to RDR	Framing error
0	0	0	1	Transferred to RDR	Parity error
1	1	1	0	Lost	Overflow error + framing error
1	1	0	1	Lost	Overflow error + parity error
0	0	1	1	Transferred to RDR	Framing error + parity error
1	1	1	1	Lost	Overflow error + framing error + parity error

Note: \* The RDRF flag retains the state it had before data reception.

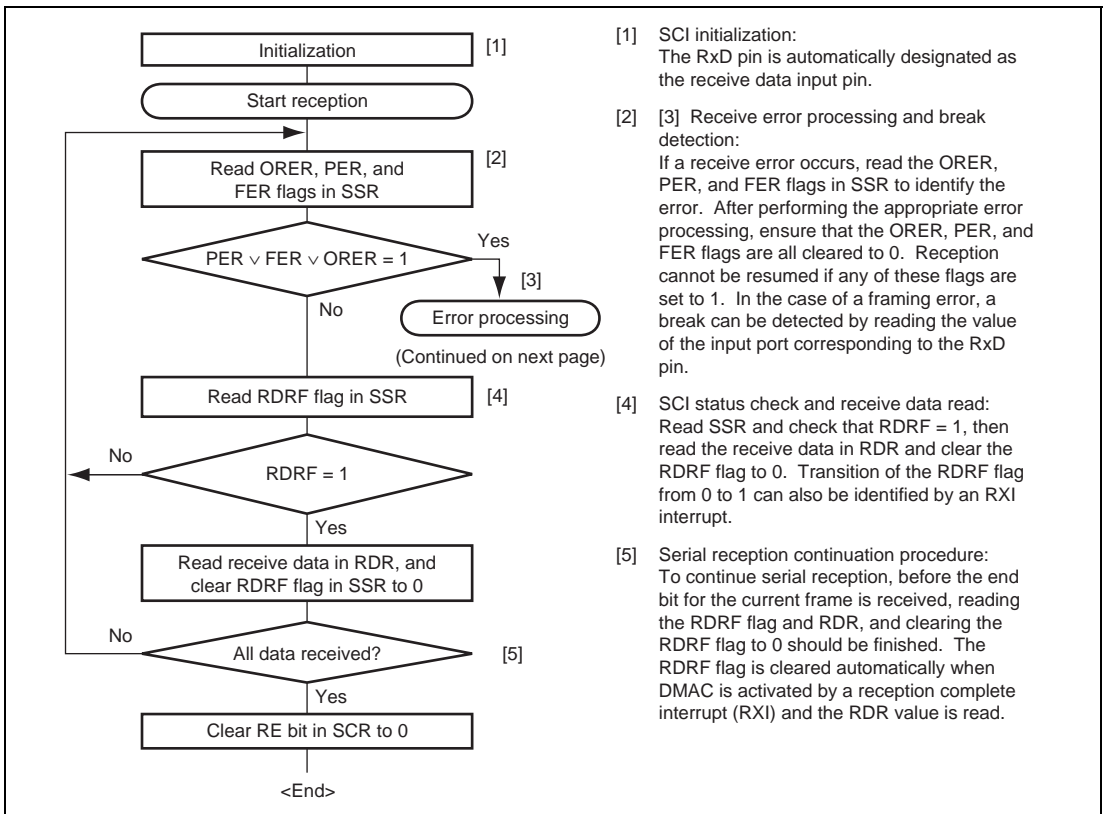
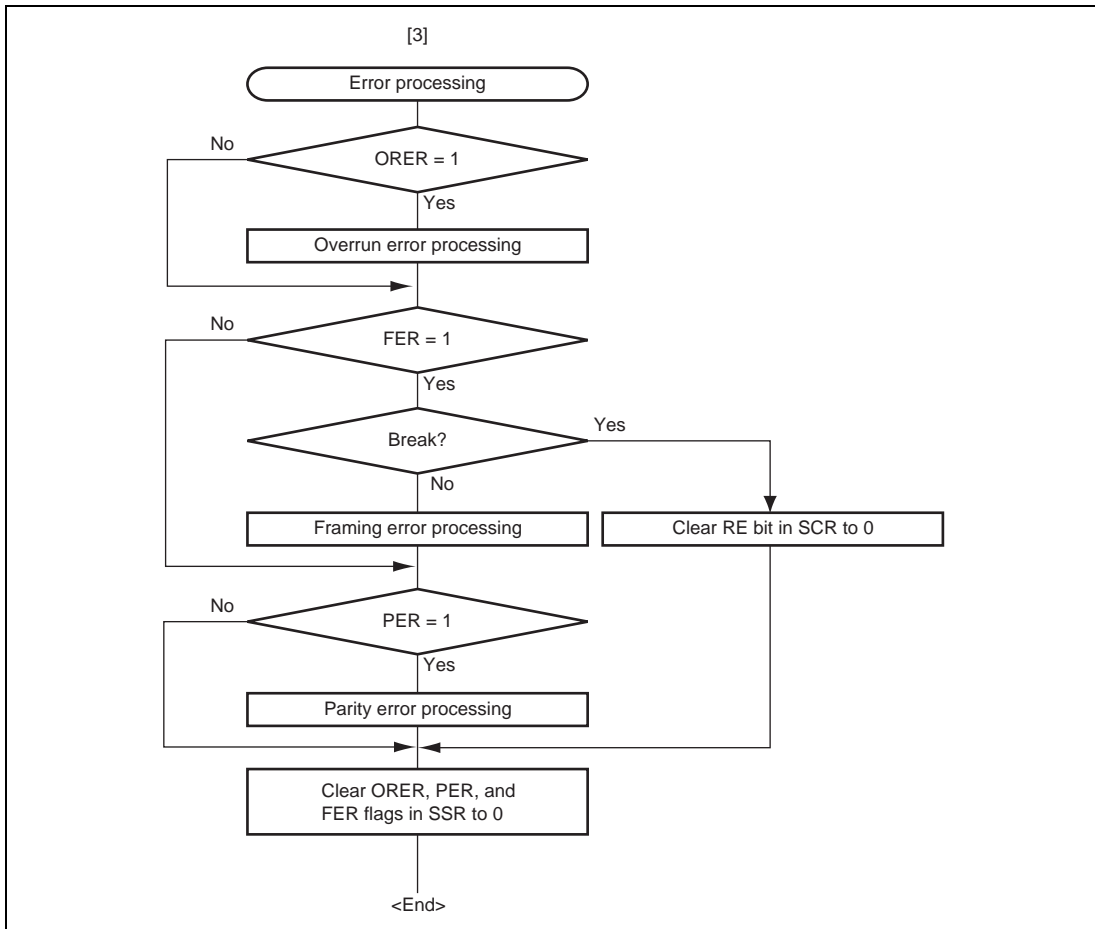


Figure 12.12 Sample Serial Data Reception Flowchart (1)



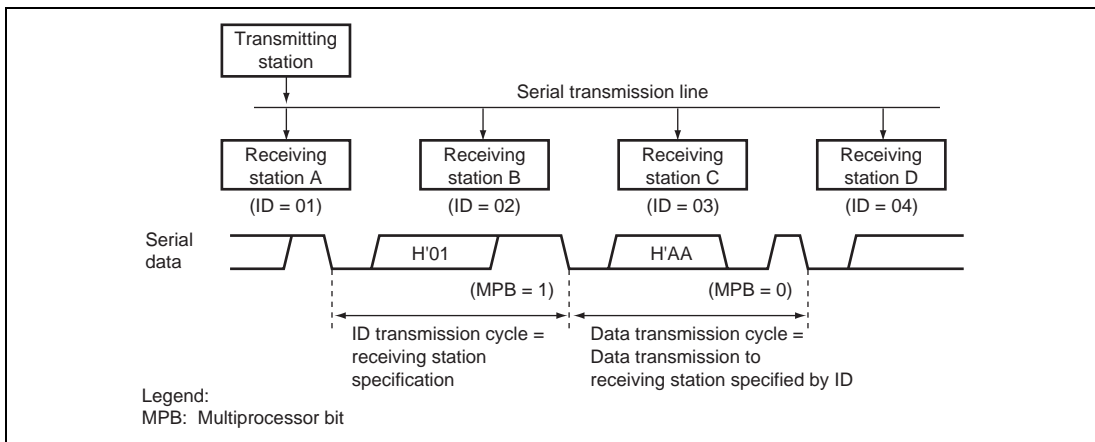
**Figure 12.12 Sample Serial Data Reception Flowchart (2)**

## 12.5 Multiprocessor Communication Function

Use of the multiprocessor communication function enables data transfer between a number of processors sharing communication lines by asynchronous serial communication using the multiprocessor format, in which a multiprocessor bit is added to the transfer data. When multiprocessor communication is performed, each receiving station is addressed by a unique ID code. The serial communication cycle consists of two component cycles; an ID transmission cycle that specifies the receiving station, and a data transmission cycle. The multiprocessor bit is used to differentiate between the ID transmission cycle and the data transmission cycle. If the multiprocessor bit is 1, the cycle is an ID transmission cycle; if the multiprocessor bit is 0, the cycle is a data transmission cycle. Figure 12.13 shows an example of inter-processor communication using the multiprocessor format. The transmitting station first sends the ID code of the receiving station with which it wants to perform serial communication as data with a 1 multiprocessor bit added. It then sends transmit data as data with a 0 multiprocessor bit added. When data with a 1 multiprocessor bit is received, the receiving station compares that data with its own ID. The station whose ID matches then receives the data sent next. Stations whose ID do not match continue to skip data until data with a 1 multiprocessor bit is again received.

The SCI uses the MPIE bit in SCR to implement this function. When the MPIE bit is set to 1, transfer of receive data from RSR to RDR, error flag detection, and setting the SSR status flags, RDRF, FER, and ORER to 1, are inhibited until data with a 1 multiprocessor bit is received. On reception of a receive character with a 1 multiprocessor bit, the MPB bit in SSR is set to 1 and the MPIE bit is automatically cleared, thus normal reception is resumed. If the RIE bit in SCR is set to 1 at this time, an RXI interrupt is generated.

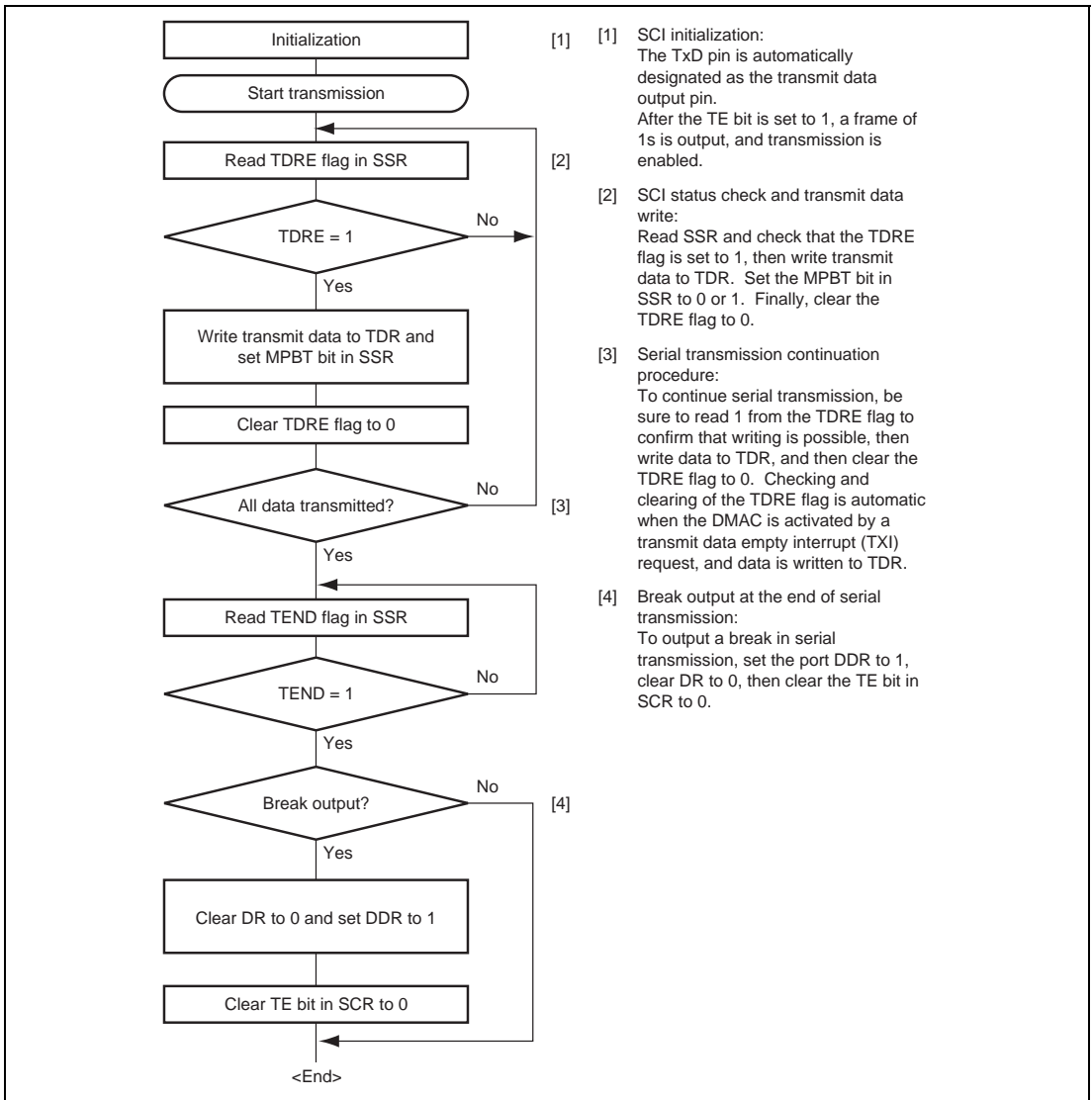
When the multiprocessor format is selected, the parity bit setting is rendered invalid. All other bit settings are the same as those in normal asynchronous mode. The clock used for multiprocessor communication is the same as that in normal asynchronous mode.



**Figure 12.13 Example of Communication Using Multiprocessor Format (Transmission of Data H'AA to Receiving Station A)**

## 12.5.1 Multiprocessor Serial Data Transmission

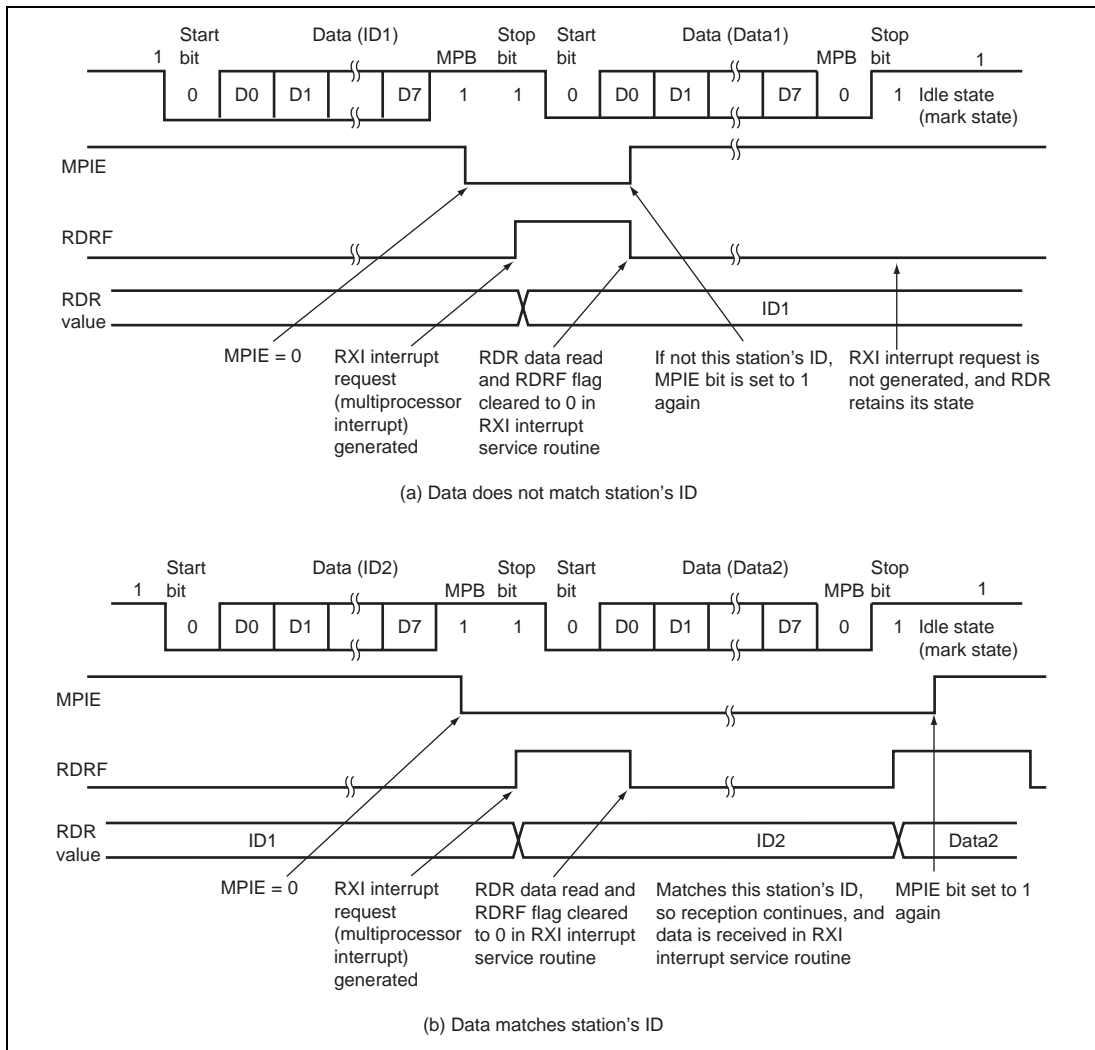
Figure 12.14 shows a sample flowchart for multiprocessor serial data transmission. For an ID transmission cycle, set the MPBT bit in SSR to 1 before transmission. For a data transmission cycle, clear the MPBT bit in SSR to 0 before transmission. All other SCI operations are the same as those in asynchronous mode.



**Figure 12.14 Sample Multiprocessor Serial Data Transmission Flowchart**

## 12.5.2 Multiprocessor Serial Data Reception

Figure 12.16 shows a sample flowchart for multiprocessor serial data reception. If the MPIE bit in SCR is set to 1, data is skipped until data with a 1 multiprocessor bit is sent. On receiving data with a 1 multiprocessor bit, the receive data is transferred to RDR. An RXI interrupt request is generated at this time. All other SCI operations are the same as in asynchronous mode. Figure 12.15 shows an example of SCI operation for multiprocessor format reception.



**Figure 12.15 Example of SCI Operation in Reception  
(Example with 8-Bit Data, Multiprocessor Bit, One Stop Bit)**



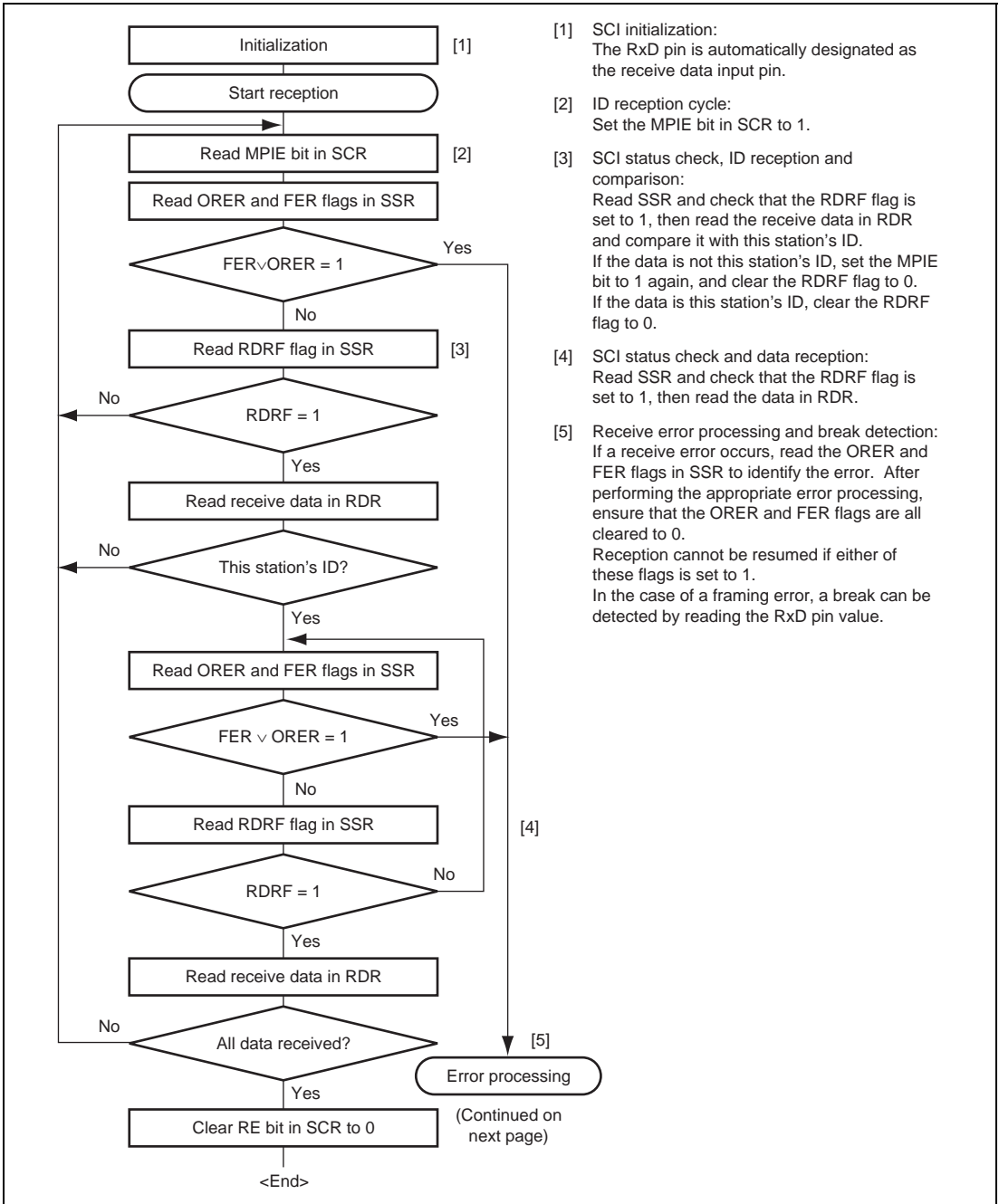
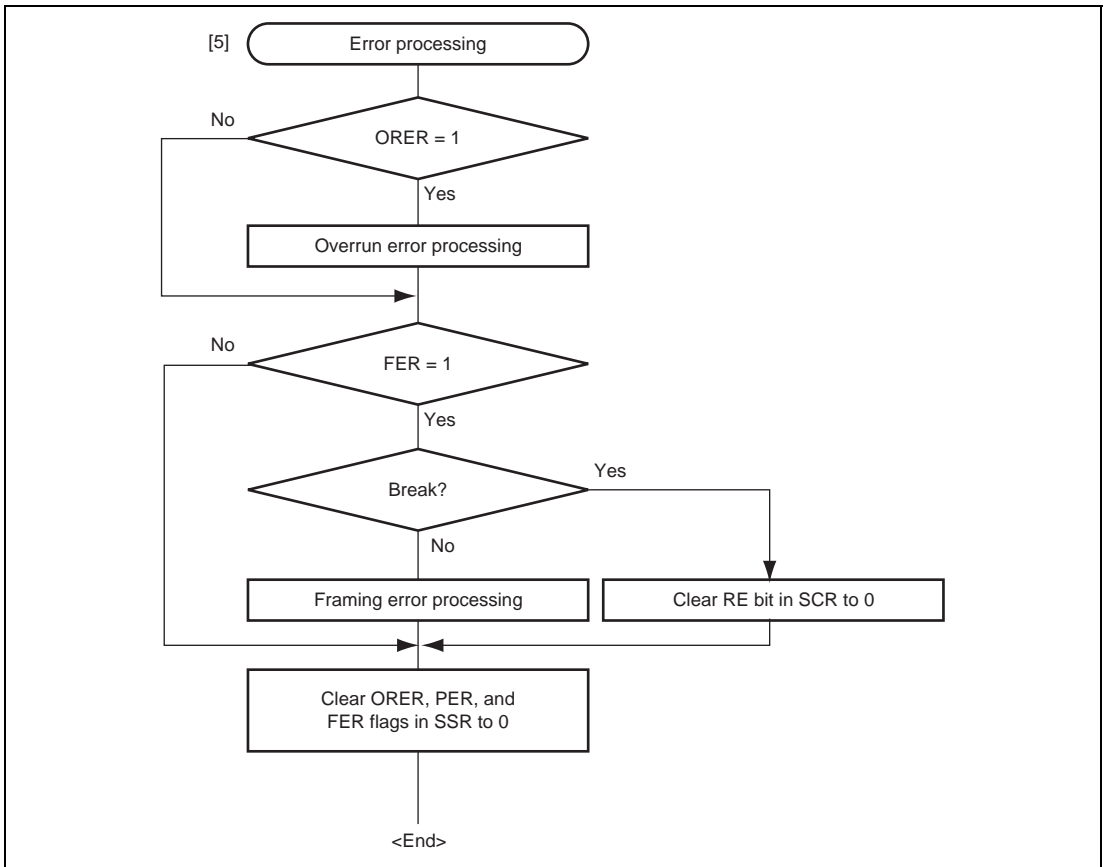
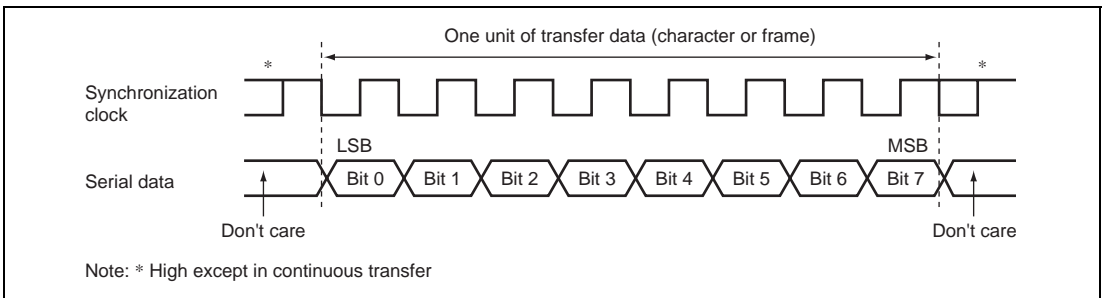


Figure 12.16 Sample Multiprocessor Serial Data Reception Flowchart (1)

**Figure 12.16 Sample Multiprocessor Serial Data Reception Flowchart (2)**

## 12.6 Operation in Clocked Synchronous Mode

Figure 12.17 shows the general format for clocked synchronous communication. In clocked synchronous mode, data is transmitted or received synchronous with clock pulses. In clocked synchronous serial communication, data on the transmission line is output from one falling edge of the serial clock to the next. In clocked synchronous mode, the SCI receives data in synchronous with the rising edge of the serial clock. After 8-bit data is output, the transmission line holds the MSB state. In clocked synchronous mode, no parity or multiprocessor bit is added. Inside the SCI, the transmitter and receiver are independent units, enabling full-duplex communication through the use of a common clock. Both the transmitter and the receiver also have a double-buffered structure, so data can be read from or written during transmission or reception, enabling continuous data transfer.



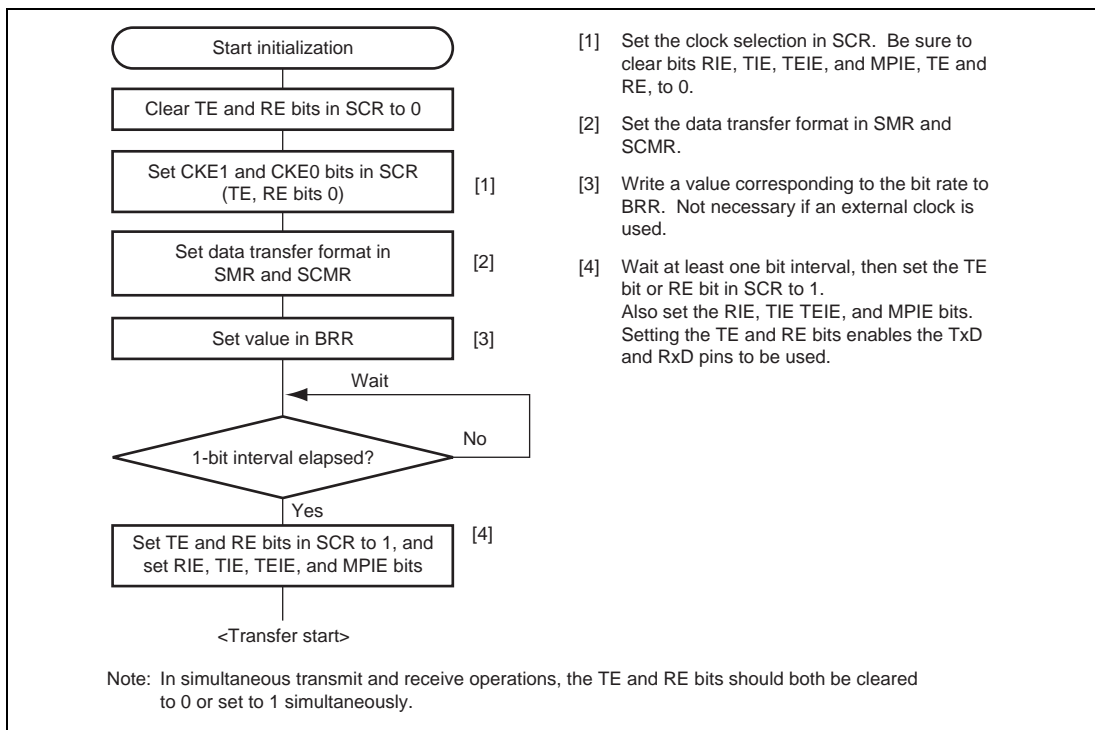
**Figure 12.17 Data Format in Synchronous Communication (For LSB-First)**

### 12.6.1 Clock

Either an internal clock generated by the on-chip baud rate generator or an external synchronization clock input at the SCK pin can be selected, according to the setting of CKE0 and CKE1 bits in SCR. When the SCI is operated on an internal clock, the serial clock is output from the SCK pin. Eight serial clock pulses are output in the transfer of one character, and when no transfer is performed the clock is fixed high.

## 12.6.2 SCI Initialization (Clocked Synchronous Mode)

Before transmitting and receiving data, the TE and RE bits in SCR should be cleared to 0, then the SCI should be initialized as described in a sample flowchart in figure 12.18. When the operating mode, or transfer format, is changed for example, the TE and RE bits must be cleared to 0 before making the change using the following procedure. When the TE bit is cleared to 0, the TDRE flag is set to 1. Note that clearing the RE bit to 0 does not change the contents of the RDRF, PER, FER, and ORER flags, or the contents of RDR.



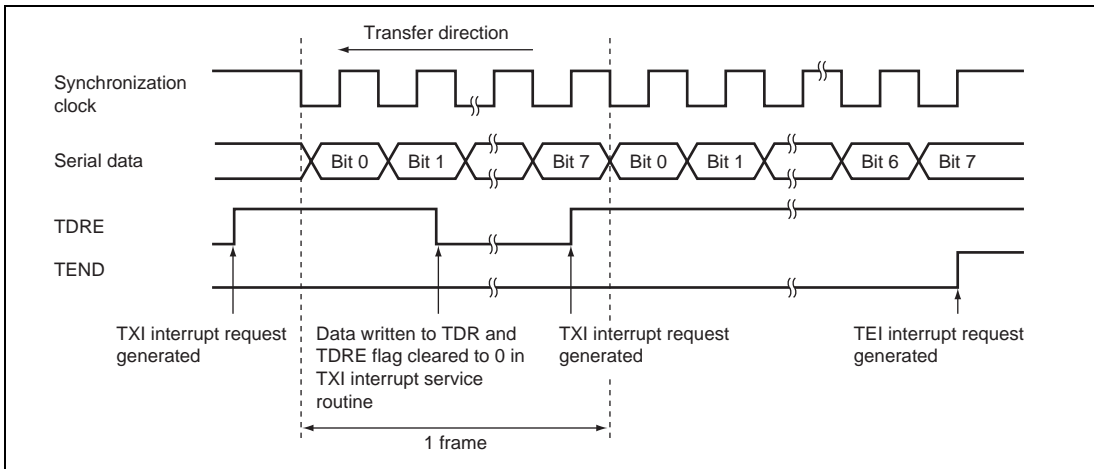
**Figure 12.18 Sample SCI Initialization Flowchart**

### 12.6.3 Serial Data Transmission (Clocked Synchronous Mode)

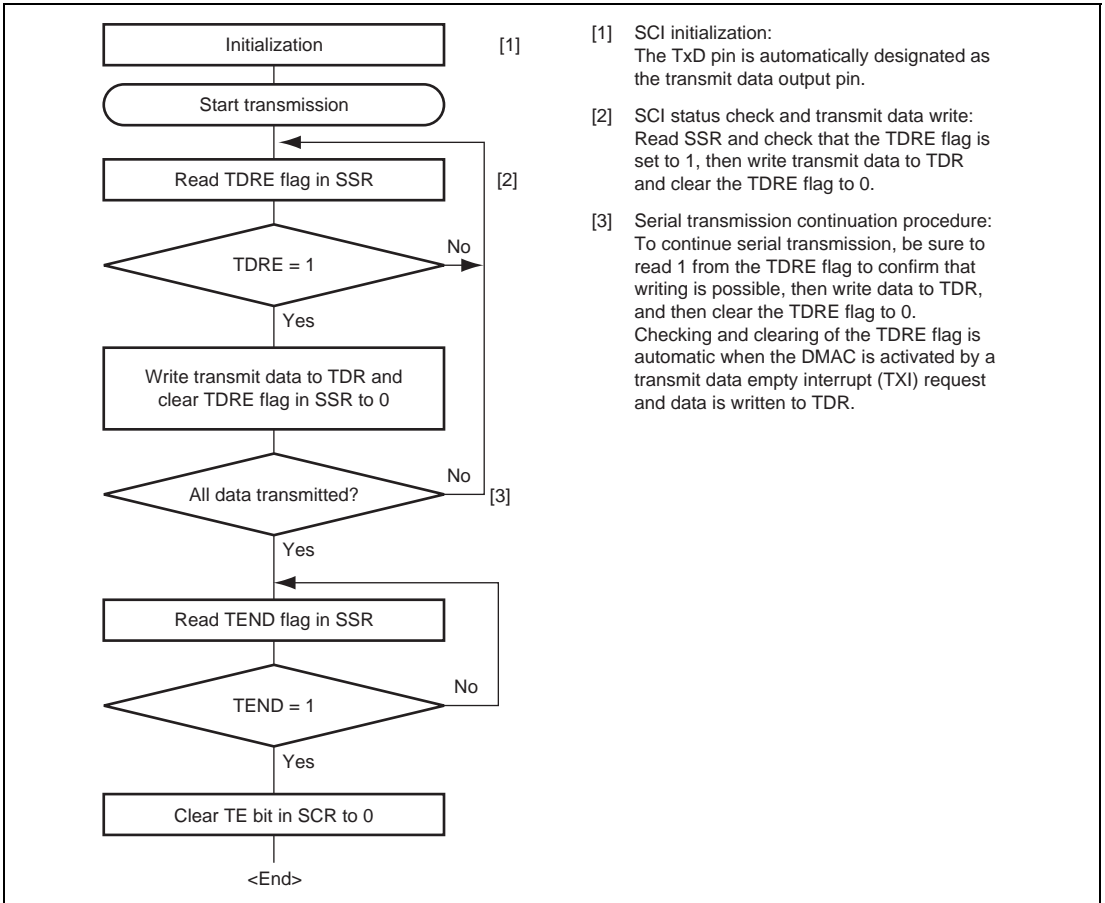
Figure 12.19 shows an example of SCI operation for transmission in clocked synchronous mode. In serial transmission, the SCI operates as described below.

1. The SCI monitors the TDRE flag in SSR, and if the flag is 0, the SCI recognizes that data has been written to TDR, and transfers the data from TDR to TSR.
2. After transferring data from TDR to TSR, the SCI sets the TDRE flag to 1 and starts transmission. If the TIE bit in SCR is set to 1 at this time, a transmit data empty interrupt (TXI) is generated. Continuous transmission is possible because the TXI interrupt routine writes the next transmit data to TDR before transmission of the current transmit data has been completed.
3. 8-bit data is sent from the TxD pin synchronized with the output clock when output clock mode has been specified, and synchronized with the input clock when use of an external clock has been specified.
4. The SCI checks the TDRE flag at the timing for sending the MSB (bit 7).
5. If the TDRE flag is cleared to 0, data is transferred from TDR to TSR, and serial transmission of the next frame is started.
6. If the TDRE flag is set to 1, the TEND flag in SSR is set to 1, and the TDRE flag maintains the output state of the last bit. If the TEIE bit in SCR is set to 1 at this time, a TEI interrupt request is generated. The SCK pin is fixed high.

Figure 12.20 shows a sample flow chart for serial data transmission. Even if the TDRE flag is cleared to 0, transmission will not start while a receive error flag (ORER, FER, or PER) is set to 1. Make sure that the receive error flags are cleared to 0 before starting transmission. Note that clearing the RE bit to 0 does not clear the receive error flags.



**Figure 12.19 Sample SCI Transmission Operation in Clocked Synchronous Mode**

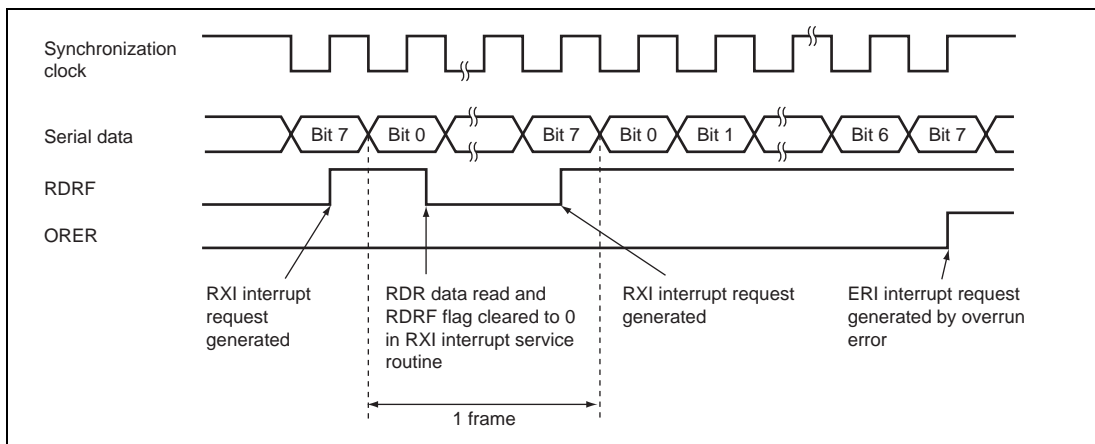


**Figure 12.20 Sample Serial Data Transmission Flowchart**

### 12.6.4 Serial Data Reception (Clocked Synchronous Mode)

Figure 12.21 shows an example of SCI operation for reception in clocked synchronous mode. In serial reception, the SCI operates as described below.

1. The SCI performs internal initialization synchronous with a synchronous clock input or output, starts receiving data, and stores the received data in RSR.
2. If an overrun error occurs (when reception of the next data is completed while the RDRF flag in SSR is still set to 1), the ORER bit in SSR is set to 1. If the RIE bit in SCR is set to 1 at this time, an ERI interrupt request is generated, receive data is not transferred to RDR, and the RDRF flag remains to be set to 1.
3. If reception is completed successfully, the RDRF bit in SSR is set to 1, and receive data is transferred to RDR. If the RIE bit in SCR is set to 1 at this time, an RXI interrupt request is generated. Continuous reception is possible because the RXI interrupt routine reads the receive data transferred to RDR before reception of the next receive data has finished.

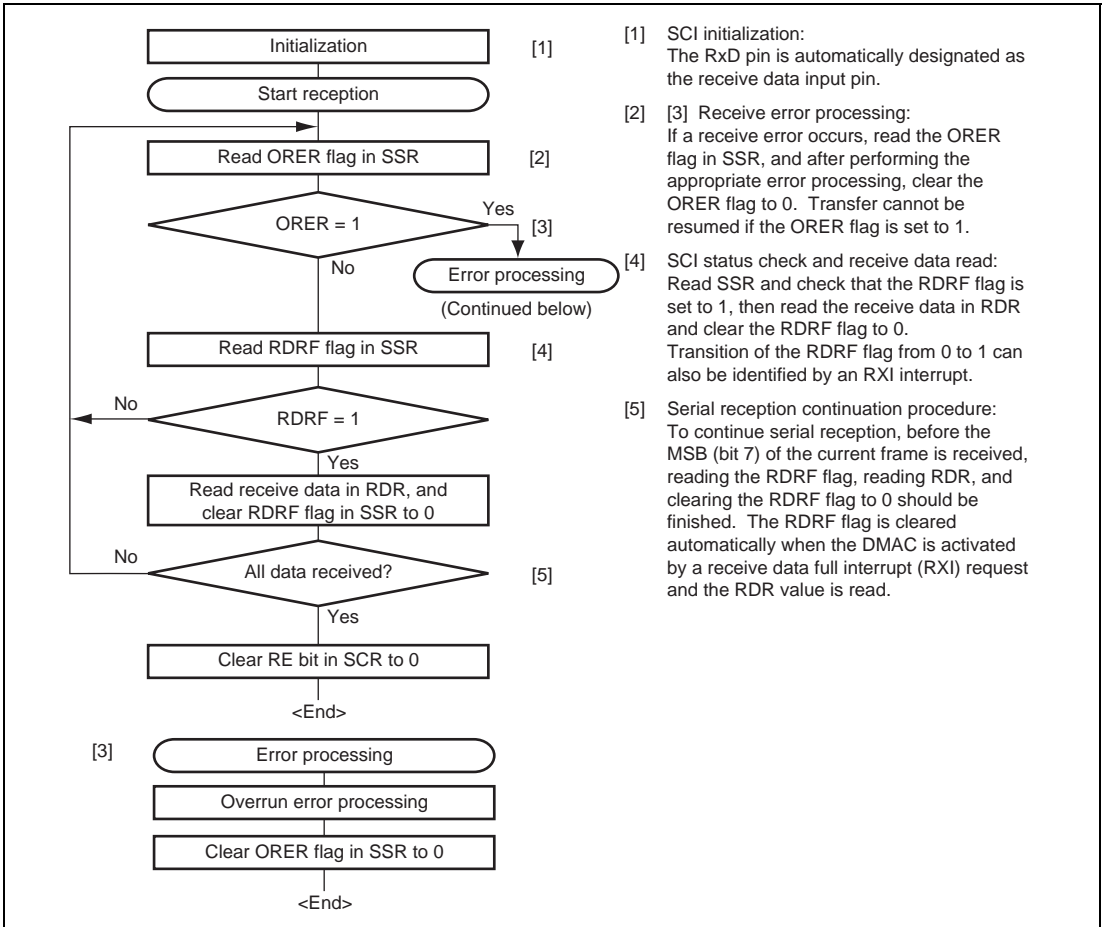


**Figure 12.21 Example of SCI Operation in Reception**

Reception cannot be resumed while a receive error flag is set to 1. Accordingly, clear the ORER, FER, PER, and RDRF bits to 0 before resuming reception. Figure 12.22 shows a sample flow chart for serial data reception.

When the internal clock is selected during reception, the synchronization clock will be output until an overrun error occurs or the RE bit is cleared. To receive data in frame units, a dummy data of one frame must be transmitted simultaneously.

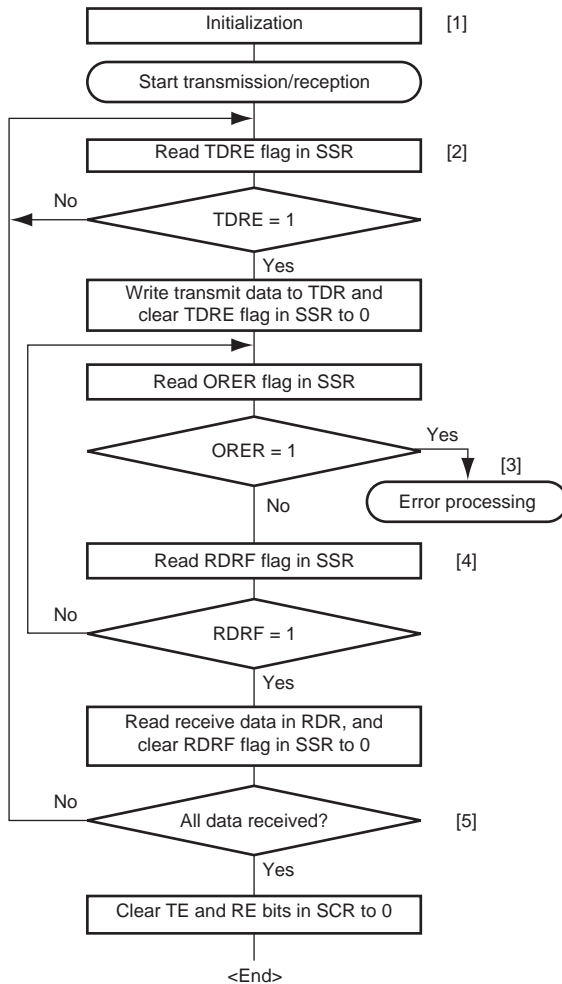




**Figure 12.22 Sample Serial Data Reception Flowchart**

### 12.6.5 Simultaneous Serial Data Transmission and Reception (Clocked Synchronous Mode)

Figure 12.23 shows a sample flowchart for simultaneous serial transmit and receive operations. The following procedure should be used for simultaneous serial data transmit and receive operations. To switch from transmit mode to simultaneous transmit and receive mode, after checking that the SCI has finished transmission and the TDRE and TEND flags are set to 1, clear TE to 0. Then simultaneously set TE and RE to 1 with a single instruction. To switch from receive mode to simultaneous transmit and receive mode, after checking that the SCI has finished reception, clear RE to 0. Then after checking that the RDRF and receive error flags (ORER, FER, and PER) are cleared to 0, simultaneously set TE and RE to 1 with a single instruction.



- [1] SCI initialization:  
The TxD pin is designated as the transmit data output pin, and the RxD pin is designated as the receive data input pin, enabling simultaneous transmit and receive operations.
- [2] SCI status check and transmit data write:  
Read SSR and check that the TDRE flag is set to 1, then write transmit data to TDR and clear the TDRE flag to 0. Transition of the TDRE flag from 0 to 1 can also be identified by a TXI interrupt.
- [3] Receive error processing:  
If a receive error occurs, read the ORER flag in SSR, and after performing the appropriate error processing, clear the ORER flag to 0. Transmission/reception cannot be resumed if the ORER flag is set to 1.
- [4] SCI status check and receive data read:  
Read SSR and check that the RDRF flag is set to 1, then read the receive data in RDR and clear the RDRF flag to 0. Transition of the RDRF flag from 0 to 1 can also be identified by an RXI interrupt.
- [5] Serial transmission/reception continuation procedure:  
To continue serial transmission/reception, before the MSB (bit 7) of the current frame is received, finish reading the RDRF flag, reading RDR, and clearing the RDRF flag to 0. Also, before the MSB (bit 7) of the current frame is transmitted, read 1 from the TDRE flag to confirm that writing is possible. Then write data to TDR and clear the TDRE flag to 0. Checking and clearing of the TDRE flag is automatic when the DMAC is activated by a transmit data empty interrupt (TXI) request and data is written to TDR. Also, the RDRF flag is cleared automatically when the DMAC is activated by a receive data full interrupt (RXI) request and the RDR value is read.

Note: When switching from transmit or receive operation to simultaneous transmit and receive operations, first clear the TE bit and RE bit to 0, then set both these bits to 1 simultaneously.

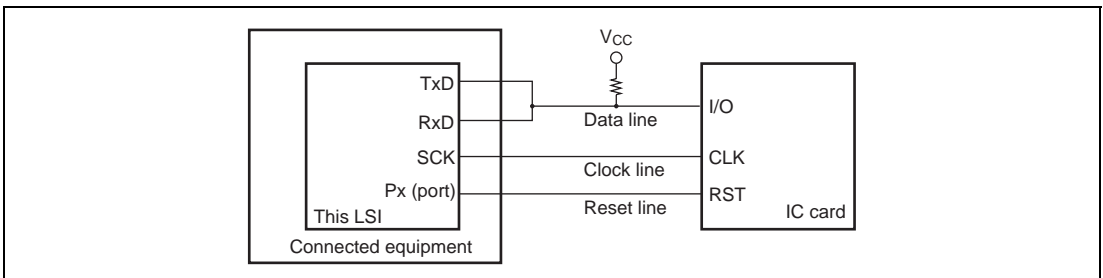
**Figure 12.23 Sample Flowchart of Simultaneous Serial Data Transmit and Receive Operations**

## 12.7 Operation in Smart Card Interface

The SCI supports an IC card (Smart Card) interface that conforms to ISO/IEC 7816-3 (Identification Card) as a serial communication interface extension function. Switching between the normal serial communication interface and the Smart Card interface mode is carried out by means of a register setting.

### 12.7.1 Pin Connection Example

Figure 12.24 shows an example of connection with the Smart Card. In communication with an IC card, as both transmission and reception are carried out on a single data transmission line, the TxD pin and RxD pin should be connected to the LSI pin. The data transmission line should be pulled up to the  $V_{CC}$  power supply with a resistor. If an IC card is not connected, and the TE and RE bits are both set to 1, closed transmission/reception is possible, enabling self-diagnosis to be carried out. When the clock generated on the Smart Card interface is used by an IC card, the SCK pin output is input to the CLK pin of the IC card. This LSI port output is used as the reset signal.

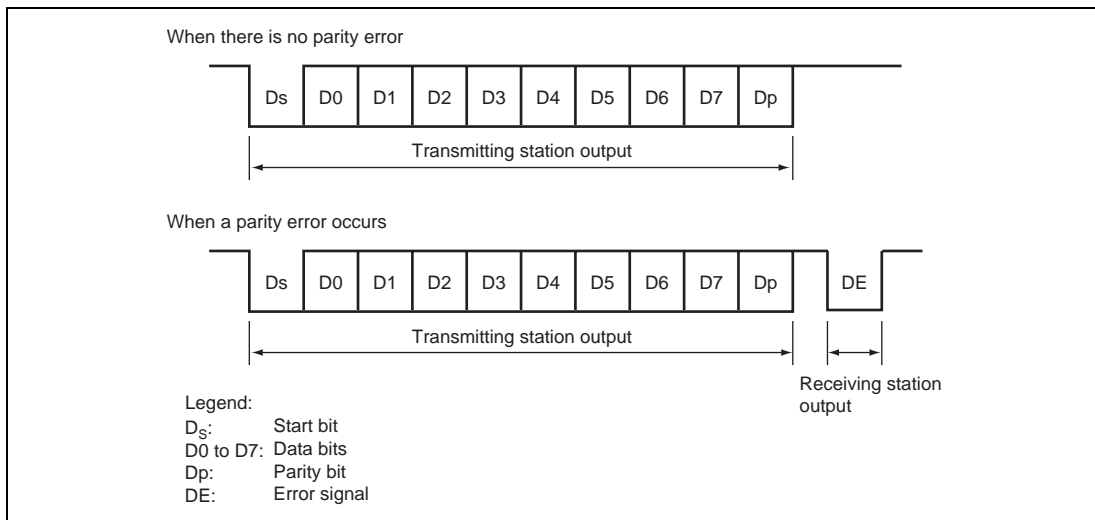


**Figure 12.24 Schematic Diagram of Smart Card Interface Pin Connections**

### 12.7.2 Data Format (Except for Block Transfer Mode)

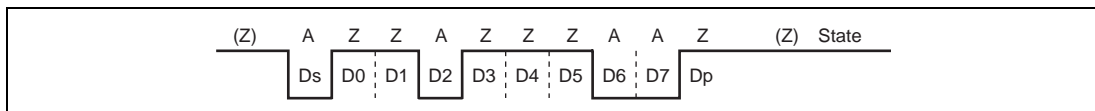
Figure 12.25 shows the transfer data format in Smart Card interface mode.

- One frame consists of 8-bit data plus a parity bit in asynchronous mode.
- In transmission, a guard time of at least 2 etu (Elementary time unit: the time for transfer of one bit) is left between the end of the parity bit and the start of the next frame.
- If a parity error is detected during reception, a low error signal level is output for one etu period, 10.5 etu after the start bit.
- If an error signal is sampled during transmission, the same data is retransmitted automatically after a delay of 2 etu or longer.



**Figure 12.25 Normal Smart Card Interface Data Format**

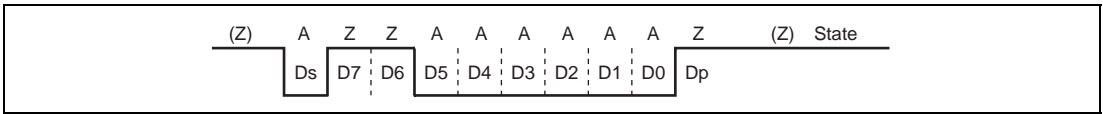
Data transfer with other types of IC cards (direct convention and inverse convention) are performed as described in the following.



**Figure 12.26 Direct Convention (SDIR = SINV = O/E = 0)**

With the direction convention type IC and the above sample start character, the logic 1 level corresponds to state Z and the logic 0 level to state A, and transfer is performed in LSB-first order. The start character data above is H'3B. For the direct convention type, clear the SDIR and SINV

bits in SCMR to 0. According to Smart Card regulations, clear the  $O/\bar{E}$  bit in SMR to 0 to select even parity mode.



**Figure 12.27 Inverse Convention (SDIR = SINV =  $O/\bar{E}$  = 1)**

With the inverse convention type, the logic 1 level corresponds to state A and the logic 0 level to state Z, and transfer is performed in MSB-first order. The start character data for the above is H'3F. For the inverse convention type, set the SDIR and SINV bits in SCMR to 1. According to Smart Card regulations, even parity mode is the logic 0 level of the parity bit, and corresponds to state Z. In this LSI, the SINV bit inverts only data bits D0 to D7. Therefore, set the  $O/\bar{E}$  bit in SMR to 1 to invert the parity bit for both transmission and reception.

### 12.7.3 Clock

As a transmit/receive clock, only an internal clock which is generated by an on-chip baud rate generator can be used. When clock output is selected by setting CKE0 to 1, a clock with a frequency S times the bit rate is output from the SCK pin.

Note: Symbol S is the value of S described in section 12.3.11, Bit Rate Register (BRR).

### 12.7.4 Block Transfer Mode

Operation in block transfer mode is the same as that in the normal Smart Card interface mode, except for the following points.

- In reception, though the parity check is performed, no error signal is output even if an error is detected. However, the PER bit in SSR is set to 1 and must be cleared before receiving the parity bit of the next frame.
- In transmission, a guard time of at least 1 etu is left between the end of the parity bit and the start of the next frame.
- In transmission, because retransmission is not performed, the TEND flag is set to 1, 11.5 etu after transmission start.
- As with the normal Smart Card interface, the ERS flag indicates the error signal status, but since error signal transfer is not performed, this flag is always cleared to 0.

### 12.7.5 Receive Data Sampling Timing and Reception Margin

In Smart Card interface mode an internal clock generated by the on-chip baud rate generator can only be used as a transmission/reception clock. In this mode, the SCI operates on a basic clock with a frequency of 32, 64, 372, or 256 times the transfer rate (fixed to 16 times in normal asynchronous mode) as determined by bits BCP1 and BCP0. In reception, the SCI samples the falling edge of the start bit using the basic clock, and performs internal synchronization. As shown in figure 12.28, by sampling receive data at the rising-edge of the 16th, 32nd, 186th, or 128th pulse of the basic clock, data can be latched at the middle of the bit. The reception margin is given by the following formula.

$$M = \left| \left( 0.5 - \frac{1}{2N} \right) - (L - 0.5) F - \frac{|D - 0.5|}{N} (1 + F) \right| \times 100 \text{ [%]}$$

Where M: Reception margin (%)

N: Ratio of bit rate to clock (N = 32, 64, 372, and 256)

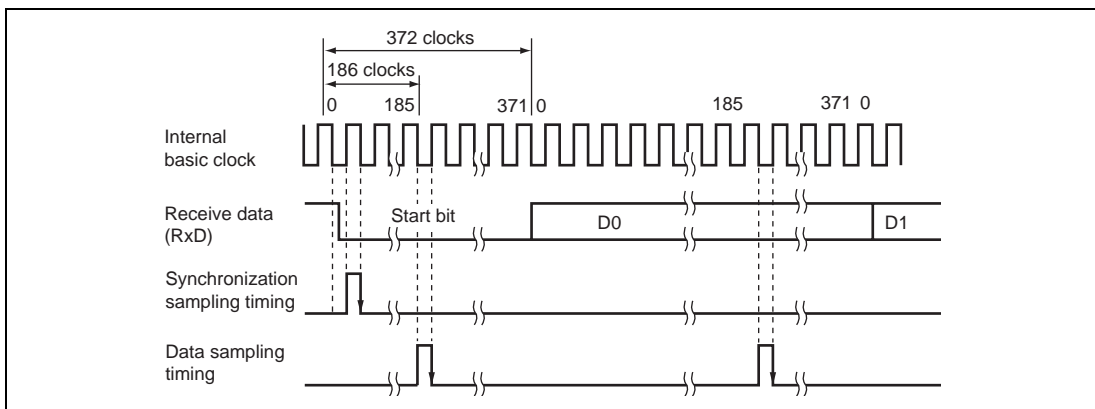
D: Clock duty (D = 0 to 1.0)

L: Frame length (L = 10)

F: Absolute value of clock frequency deviation

Assuming values of F = 0, D = 0.5 and N = 372 in the above formula, the reception margin formula is as follows.

$$\begin{aligned} M &= (0.5 - 1/2 \times 372) \times 100\% \\ &= 49.866\% \end{aligned}$$



**Figure 12.28 Receive Data Sampling Timing in Smart Card Mode  
(Using Clock of 372 Times the Transfer Rate)**

### 12.7.6 Initialization

Before transmitting and receiving data, initialize the SCI as described below. Initialization is also necessary when switching from transmit mode to receive mode, or vice versa.

1. Clear the TE and RE bits in SCR to 0.
2. Clear the error flags ERS, PER, and ORER in SSR to 0.
3. Set the GM, BLK,  $O/\bar{E}$ , BCP0, BCP1, CKS0, CKS1 bits in SMR. Set the PE bit to 1.
4. Set the SMIF, SDIR, and SINV bits in SCMR.

When the SMIF bit is set to 1, the TxD and RxD pins are both switched from ports to SCI pins, and are placed in the high-impedance state.

5. Set the value corresponding to the bit rate in BRR.
6. Set the CKE0 and CKE1 bits in SCR. Clear the TIE, RIE, TE, RE, MPIE, and TEIE bits to 0.  
If the CKE0 bit is set to 1, the clock is output from the SCK pin.
7. Wait at least one bit interval, then set the TIE, RIE, TE, and RE bits in SCR. Do not set the TE bit and RE bit at the same time, except for self-diagnosis.

To switch from receive mode to transmit mode, after checking that the SCI has finished reception, initialize the SCI, and set RE to 0 and TE to 1. Whether SCI has finished reception or not can be checked with the RDRF, PER, or ORER flags. To switch from transmit mode to receive mode, after checking that the SCI has finished transmission, initialize the SCI, and set TE to 0 and RE to 1. Whether SCI has finished transmission or not can be checked with the TEND flag.

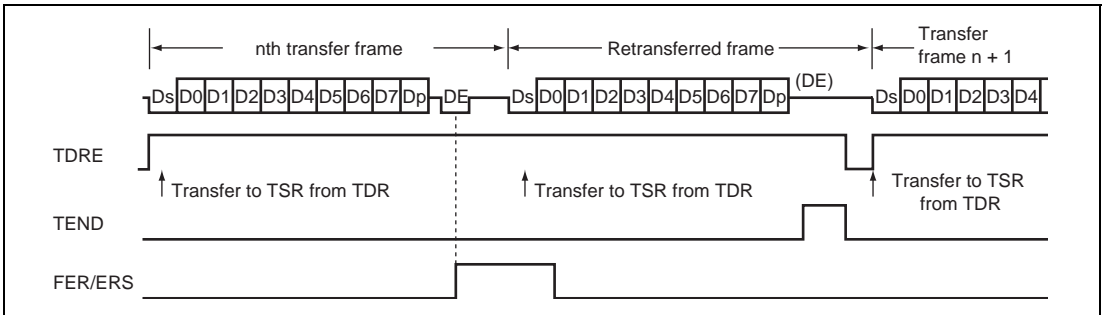
### 12.7.7 Serial Data Transmission (Except for Block Transfer Mode)

As data transmission in Smart Card interface mode involves error signal sampling and retransmission processing, the operations are different from those in normal serial communication interface mode (except for block transfer mode). Figure 12.29 illustrates the retransfer operation when the SCI is in transmit mode.

1. If an error signal is sent back from the receiving end after transmission of one frame is complete, the ERS bit in SSR is set to 1. If the RIE bit in SCR is enabled at this time, an ERI interrupt request is generated. The ERS bit in SSR should be cleared to 0 by the time the next parity bit is sampled.
2. The TEND bit in SSR is not set for a frame in which an error signal indicating an abnormality is received. Data is retransferred from TDR to TSR, and retransmitted automatically.
3. If an error signal is not sent back from the receiving end, the ERS bit in SSR is not set. Transmission of one frame, including a retransfer, is judged to have been completed, and the TEND bit in SSR is set to 1. If the TIE bit in SCR is enabled at this time, a TXI interrupt request is generated. Writing transmit data to TDR transfers the next transmit data.

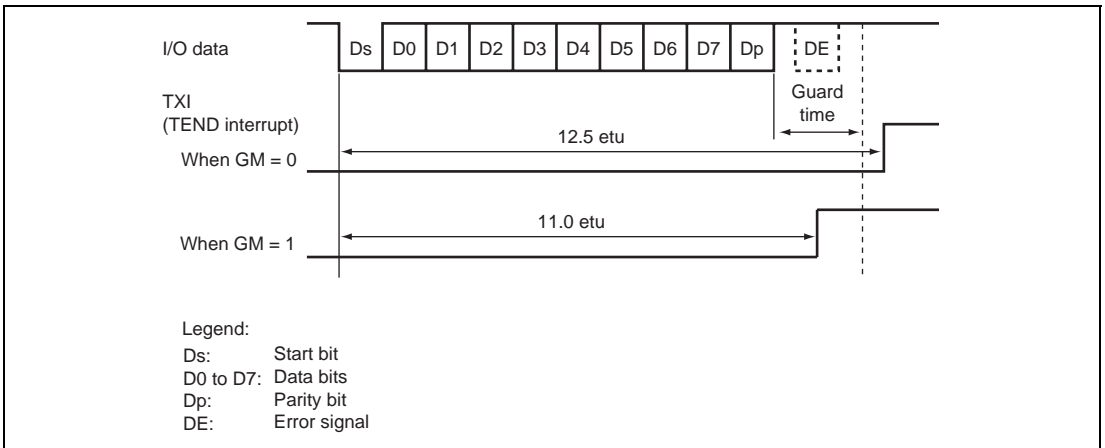
Figure 12.31 shows a flowchart for transmission. A sequence of transmit operations can be performed automatically by specifying the DMAC to be activated with a TXI interrupt source. In a transmit operation, the TDRE flag is set to 1 at the same time as the TEND flag in SSR is set, and a TXI interrupt will be generated if the TIE bit in SCR has been set to 1. If the TXI request is designated beforehand as a DMAC activation source, the DMAC will be activated by the TXI request, and transfer of the transmit data will be carried out. The TDRE and TEND flags are automatically cleared to 0 when data is transferred by the DMAC. In the event of an error, the SCI retransmits the same data automatically. During this period, the TEND flag remains cleared to 0 and the DMAC is not activated. Therefore, the SCI and DMAC will automatically transmit the specified number of bytes in the event of an error, including retransmission. However, the ERS flag is not cleared automatically when an error occurs, and so the RIE bit should be set to 1 beforehand so that an ERI request will be generated in the event of an error, and the ERS flag will be cleared. When using the DMAC for data transmission or reception, always make DMAC settings and enable the DMAC before making SCI settings. For details on DMAC settings, see section 7, DMA Controller (DMAC).





**Figure 12.29 Retransfer Operation in SCI Transmit Mode**

The timing for setting the TEND flag depends on the value of the GM bit in SMR. The TEND flag set timing is shown in figure 12.30.



**Figure 12.30 TEND Flag Generation Timing in Transmission Operation**

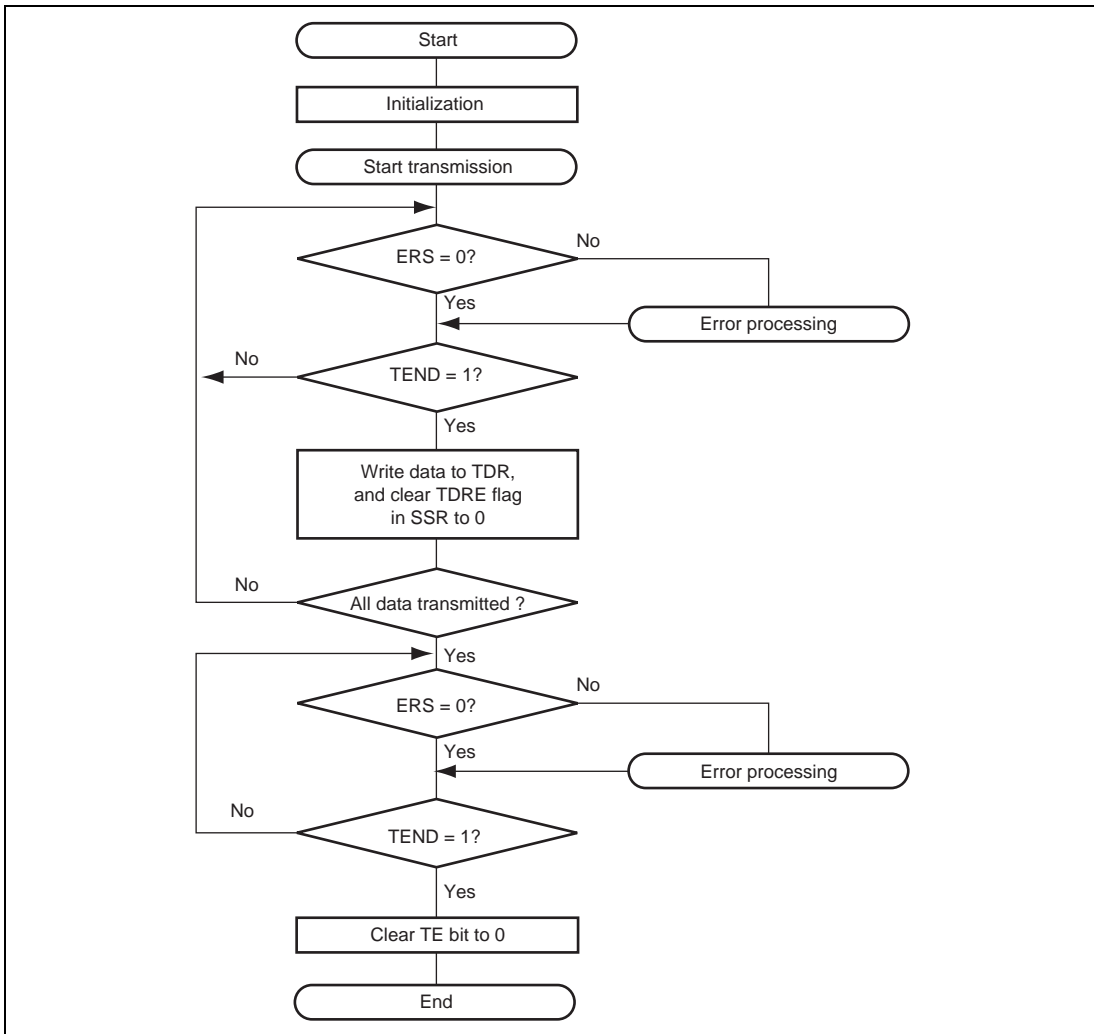


Figure 12.31 Example of Transmission Processing Flow

### 12.7.8 Serial Data Reception (Except for Block Transfer Mode)

Data reception in Smart Card interface mode uses the same operation procedure as for normal serial communication interface mode. Figure 12.32 illustrates the retransfer operation when the SCI is in receive mode.

1. If an error is found when the received parity bit is checked, the PER bit in SSR is automatically set to 1. If the RIE bit in SCR is set at this time, an ERI interrupt request is generated. The PER bit in SSR should be kept cleared to 0 until the next parity bit is sampled.
2. The RDRF bit in SSR is not set for a frame in which an error has occurred.
3. If no error is found when the received parity bit is checked, the PER bit in SSR is not set to 1, the receive operation is judged to have been completed normally, and the RDRF flag in SSR is automatically set to 1. If the RIE bit in SCR is enabled at this time, an RXI interrupt request is generated.

Figure 12.33 shows a flowchart for reception. A sequence of receive operations can be performed automatically by specifying the DMAC to be activated using an RXI interrupt source. In a receive operation, an RXI interrupt request is generated when the RDRF flag in SSR is set to 1. If the RXI request is designated beforehand as a DMAC activation source, the DMAC will be activated by the RXI request, and the receive data will be transferred. The RDRF flag is cleared to 0 automatically when data is transferred by the DMAC. If an error occurs in receive mode and the ORER or PER flag is set to 1, a transfer error interrupt (ERI) request will be generated. Hence, so the error flag must be cleared to 0. In the event of an error, the DMAC is not activated and receive data is skipped. Therefore, receive data is transferred for only the specified number of bytes in the event of an error. Even when a parity error occurs in receive mode and the PER flag is set to 1, the data that has been received is transferred to RDR and can be read from there.

Note: For details on receive operations in block transfer mode, refer to section 12.4, Operation in Asynchronous Mode.

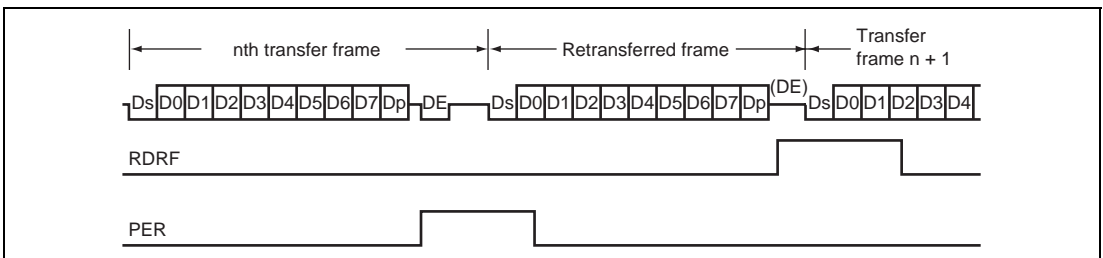
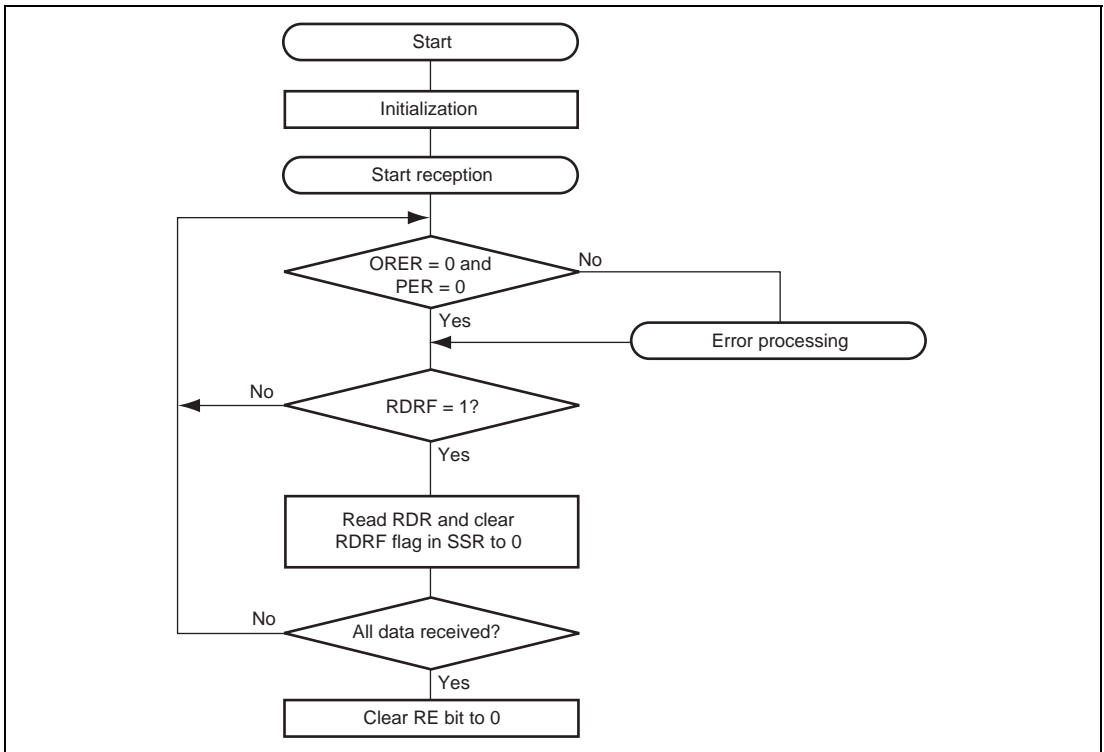


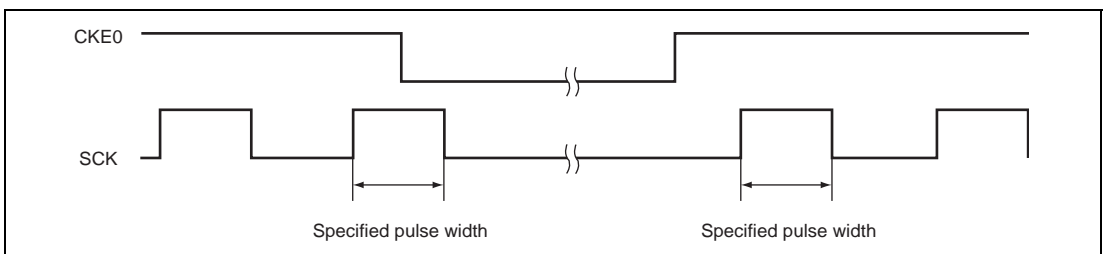
Figure 12.32 Retransfer Operation in SCI Receive Mode



**Figure 12.33 Example of Reception Processing Flow**

### 12.7.9 Clock Output Control

When the GM bit in SMR is set to 1, the clock output level can be fixed with bits CKE0 and CKE1 in SCR. At this time, the minimum clock pulse width can be made the specified width. Figure 12.34 shows the timing for fixing the clock output level. In this example, GM is set to 1, CKE1 is cleared to 0, and the CKE0 bit is controlled.



**Figure 12.34 Timing for Fixing Clock Output Level**

When turning on the power or switching between Smart Card interface mode and software standby mode, the following procedures should be followed in order to maintain the clock duty.

**Powering On:** To secure clock duty from power-on, the following switching procedure should be followed.

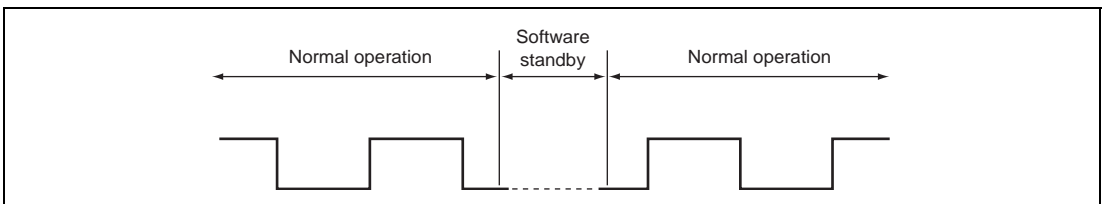
1. The initial state is port input and high impedance. Use a pull-up resistor or pull-down resistor to fix the potential.
2. Fix the SCK pin to the specified output level with the CKE1 bit in SCR.
3. Set SMR and SCMR, and switch to smart card mode operation.
4. Set the CKE0 bit in SCR to 1 to start clock output.

**When changing from smart card interface mode to software standby mode:**

1. Set the data register (DR) and data direction register (DDR) corresponding to the SCK pin to the value for the fixed output state in software standby mode.
2. Write 0 to the TE bit and RE bit in the serial control register (SCR) to halt transmit/receive operation. At the same time, set the CKE1 bit to the value for the fixed output state in software standby mode.
3. Write 0 to the CKE0 bit in SCR to halt the clock.
4. Wait for one serial clock period.  
During this interval, clock output is fixed at the specified level, with the duty preserved.
5. Make the transition to the software standby state.

**When returning to smart card interface mode from software standby mode:**

1. Exit the software standby state.
2. Write 1 to the CKE0 bit in SCR and output the clock. Signal generation is started with the normal duty.



**Figure 12.35 Clock Halt and Restart Procedure**

## 12.8 SCI Select Function (Clocked Synchronous Mode)

The SCI\_0 supports the SCI select function which allows clock synchronous communication between master LSI and one of multiple slave LSI. Figure 12.36 shows an example of communication using the SCI select function. Figure 12.37 shows the operation.

The master LSI can communicate with slave LSI\_A by bringing  $\overline{\text{SEL\_A}}$  and  $\overline{\text{SEL\_B}}$  signals low and high, respectively. In this case, the TxD0\_B pin of the slave LSI\_B is brought high-impedance state and the internal SCK0\_A signal is fixed high. This halts the communication operation of slave LSI\_B. The master LSI can communicate with slave LSI\_B by bringing the  $\overline{\text{SEL\_A}}$  and  $\overline{\text{SEL\_B}}$  signals high and low, respectively.

The slave LSI detects the selection by receiving the low level input from the  $\overline{\text{IRQ7}}$  pin and immediately executes data transmission/reception processing.

Note: The selection signals ( $\overline{\text{SEL\_A}}$  and  $\overline{\text{SEL\_B}}$ ) of the LSI must be switched while the serial clock (M\_SCK) is high after the end bit of the transmit data has been send. Note that one selection signal can be brought low at the same time.

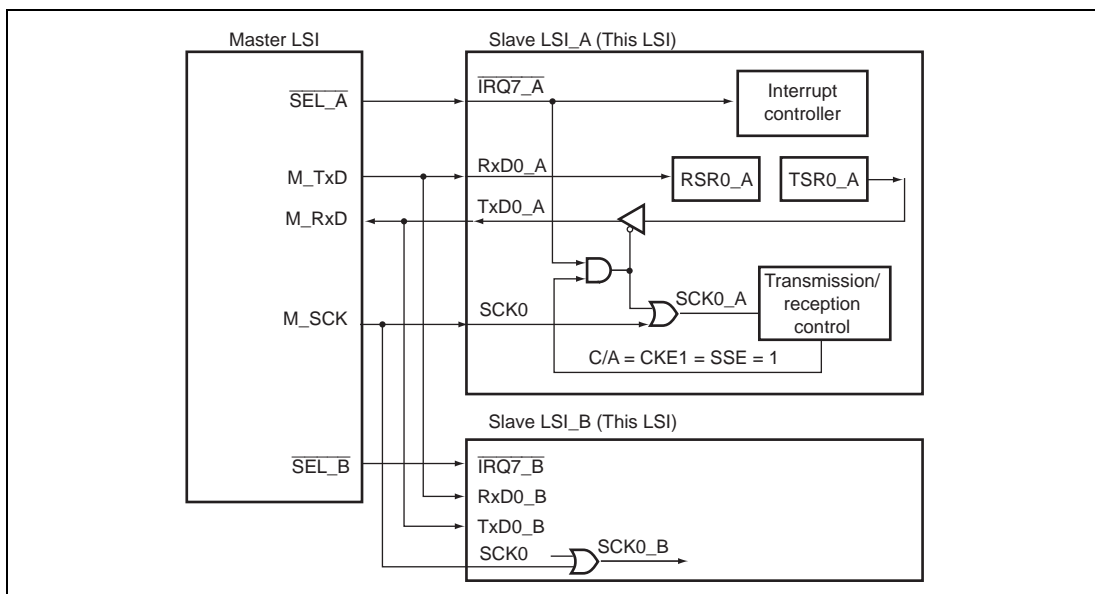
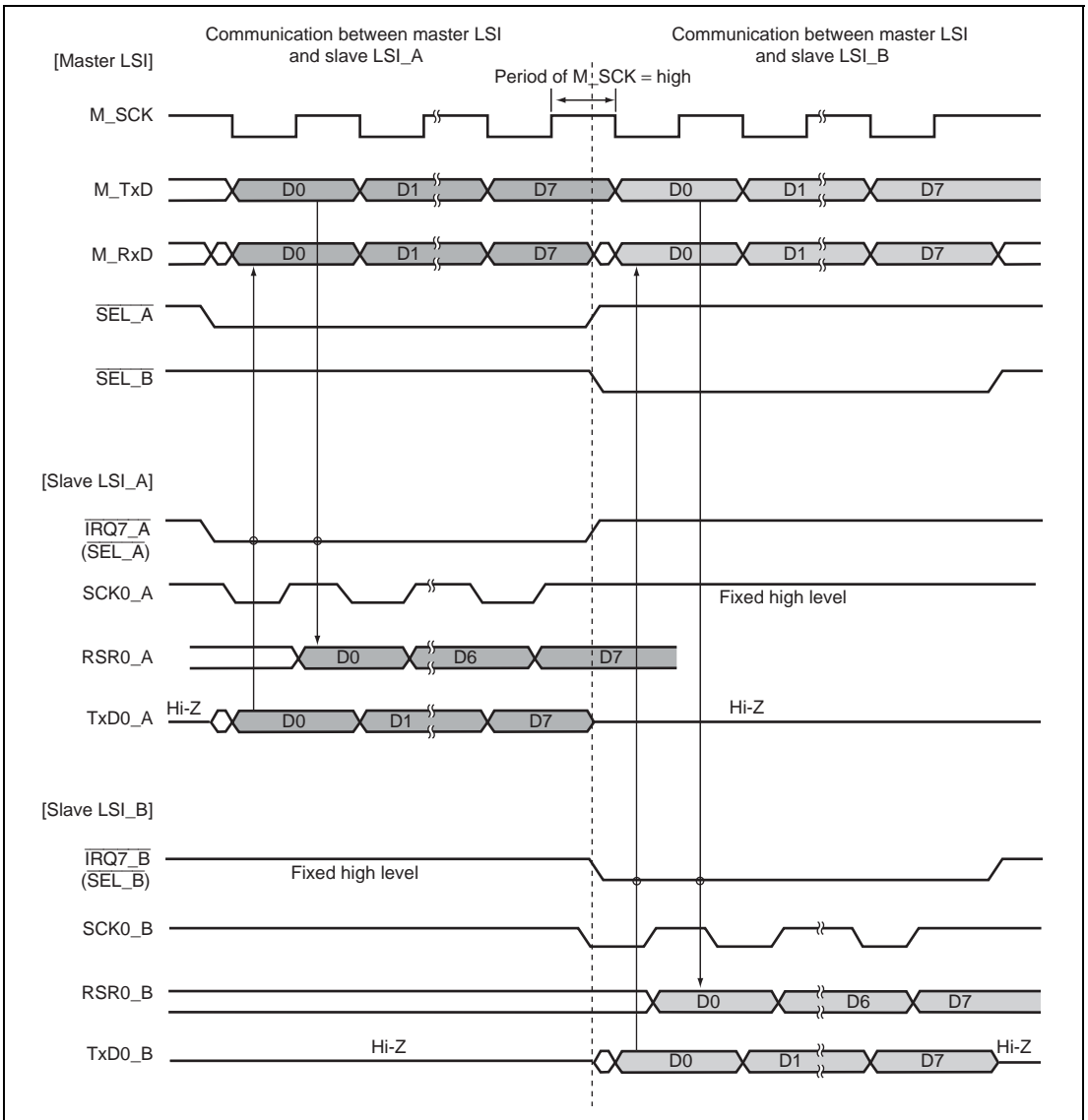


Figure 12.36 Example of Communication Using the SCI Select Function



**Figure 12.37 Example of Communication Using the SCI Select Function**

## 12.9 Interrupts

### 12.9.1 Interrupts in Normal Serial Communication Interface Mode

Table 12.12 shows the interrupt sources in normal serial communication interface mode. A different interrupt vector is assigned to each interrupt source, and individual interrupt sources can be enabled or disabled using the enable bits in SCR.

When the TDRE flag in SSR is set to 1, a TXI interrupt request is generated. When the TEND flag in SSR is set to 1, a TEI interrupt request is generated. A TXI interrupt can activate the DMAC to perform data transfer. The TDRE flag is cleared to 0 automatically when data is transferred by the DMAC.

When the RDRF flag in SSR is set to 1, an RXI interrupt request is generated. When the ORER, PER, or FER flag in SSR is set to 1, an ERI interrupt request is generated. An RXI interrupt request can activate the DMAC to transfer data. The RDRF flag is cleared to 0 automatically when data is transferred by the DMAC.

A TEI interrupt is requested when the TEND flag is set to 1 and the TEIE bit is set to 1. If a TEI interrupt and a TXI interrupt are requested simultaneously, the TXI interrupt has priority for acceptance. However, if the TDRE and TEND flags are cleared simultaneously by the TXI interrupt routine, the SCI cannot branch to the TEI interrupt routine later.

**Table 12.12 SCI Interrupt Sources**

Channel Name	Interrupt Source	Interrupt Flag	DMAC Activation	Priority*
0	ERI0	Receive Error	ORER, FER, PER	Not possible
	RX10	Receive Data Full	RDRF	Possible
	TX10	Transmit Data Empty	TDRE	Possible
	TE10	Transmission End	TEND	Not possible
2	ERI2	Receive Error	ORER, FER, PER	Not possible
	RX12	Receive Data Full	RDRF	Not possible
	TX12	Transmit Data Empty	TDRE	Not possible
	TE12	Transmission End	TEND	Not possible
				High
				Low

Note: \* This table shows the initial state immediately after a reset. The relative channel priorities can be changed by the interrupt controller.



## 12.9.2 Interrupts in Smart Card Interface Mode

Table 12.13 shows the interrupt sources in Smart Card interface mode. The transmit end interrupt (TEI) request cannot be used in this mode.

Note: In case of block transfer mode, see section 12.9.1, Interrupts in Normal Serial Communication Interface Mode.

**Table 12.13 Interrupt Sources in Smart Card Interface Mode**

Channel	Name	Interrupt Source	Interrupt Flag	DMAC Activation	Priority*
0	ERI0	Receive Error, detection	ORER, PER, ERS	Not possible	High ↑ Low
	RX10	Receive Data Full	RDRF	Possible	
	TX10	Transmit Data Empty	TEND	Possible	
2	ERI2	Receive Error, detection	ORER, PER, ERS	Not possible	High ↑ Low
	RX12	Receive Data Full	RDRF	Not possible	
	TX12	Transmit Data Empty	TEND	Not possible	

Note: \* Indicates the initial state immediately after a reset.  
Priorities in channels can be changed by the interrupt controller.

## 12.10 Usage Notes

### 12.10.1 Module Stop Mode Setting

SCI operation can be disabled or enabled using the module stop control register. The initial setting is for SCI operation to be halted. Register access is enabled by clearing module stop mode. For details, refer to section 20, Power-Down Modes.

### 12.10.2 Break Detection and Processing (Asynchronous Mode Only)

When framing error detection is performed, a break can be detected by reading the RxD pin value directly. In a break, the input from the RxD pin becomes all 0s, setting the FER flag, and possibly the PER flag. Note that as the SCI continues the receive operation after receiving a break, even if the FER flag is cleared to 0, it will be set to 1 again.

### 12.10.3 Mark State and Break Detection (Asynchronous Mode Only)

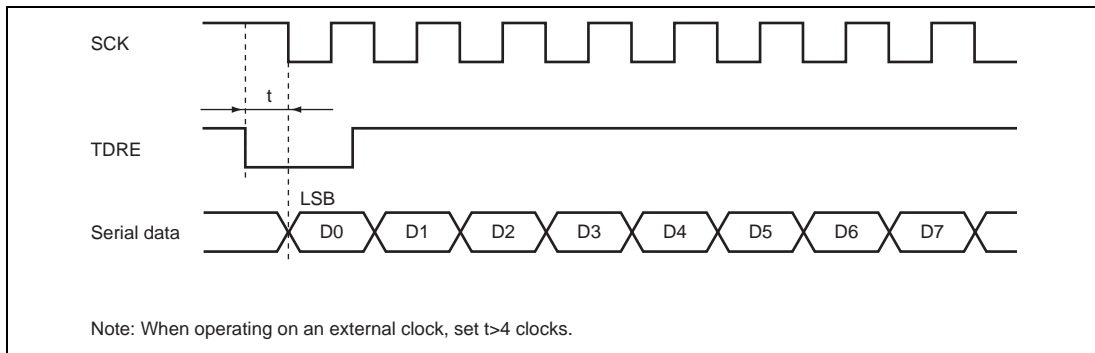
When TE is 0, the TxD pin is used as an I/O port whose direction (input or output) and level are determined by DR and DDR. This can be used to set the TxD pin to mark state (high level) or send a break during serial data transmission. To maintain the communication line at mark state until TE is set to 1, set both DDR and DR to 1. As TE is cleared to 0 at this point, the TxD pin becomes an I/O port, and 1 is output from the TxD pin. To send a break during serial transmission, first set PCR to 1 and PDR to 0, and then clear TE to 0. When TE is cleared to 0, the transmitter is initialized regardless of the current transmission state, the TxD pin becomes an I/O port, and 0 is output from the TxD pin.

### 12.10.4 Receive Error Flags and Transmit Operations (Clocked Synchronous Mode Only)

Transmission cannot be started when a receive error flag (ORER, PER, or FER) is set to 1, even if the TDRE flag is cleared to 0. Be sure to clear the receive error flags to 0 before starting transmission. Note also that receive error flags cannot be cleared to 0 even if the RE bit is cleared to 0.

### 12.10.5 Restrictions on Use of DMAC

- When an external clock source is used as the serial clock, the transmit clock should not be input until at least 5  $\phi$  clock cycles after TDR is updated by the DMAC. Misoperation may occur if the transmit clock is input within 4  $\phi$  clocks after TDR is updated. (figure 12.38)
- When RDR is read by the DMAC, be sure to set the activation source to the relevant SCI reception end interrupt (RXI).



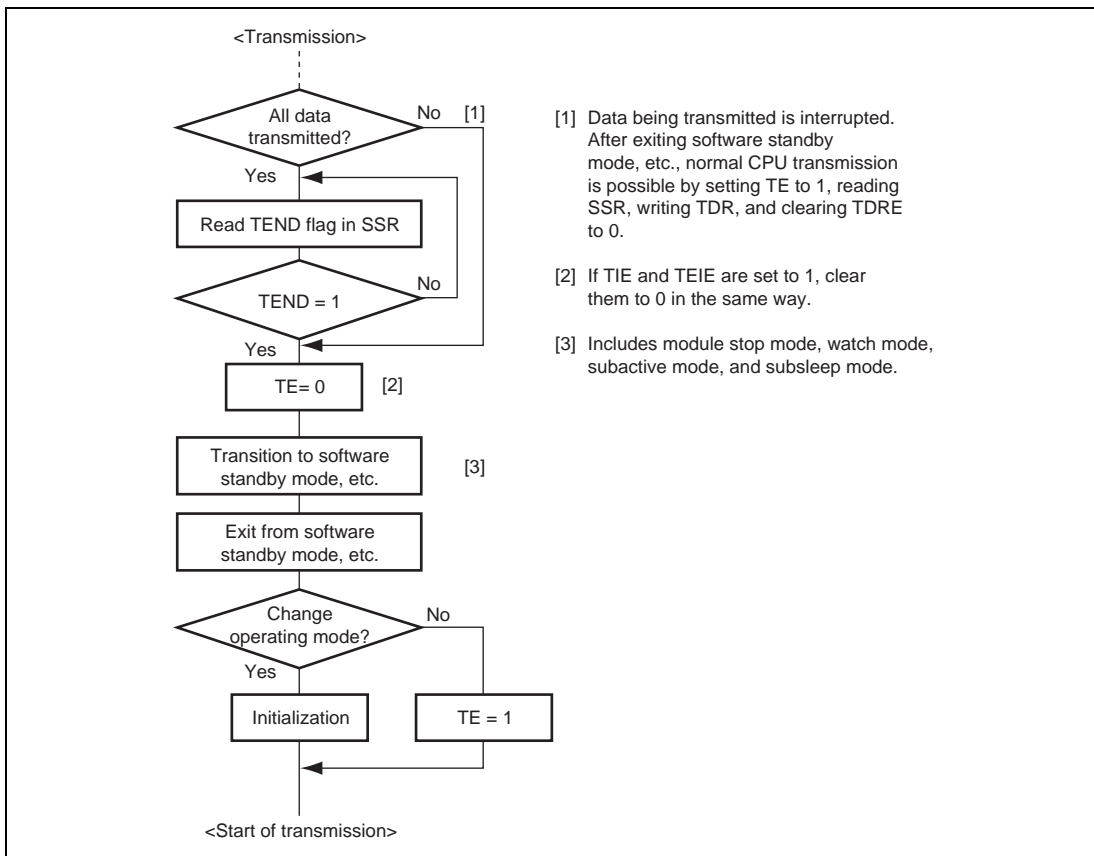
**Figure 12.38 Example of Clocked Synchronous Transmission by DMAC**

### 12.10.6 Operation in Case of Mode Transition

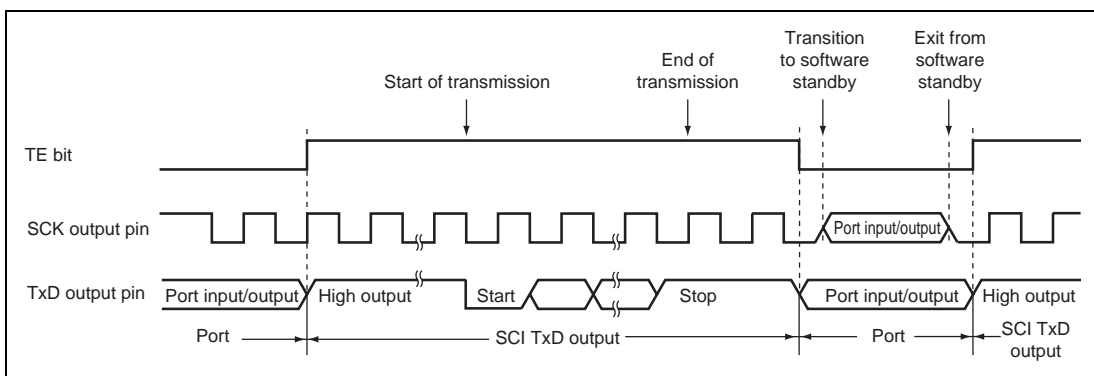
- Transmission

Operation should be stopped (by clearing TE, TIE, and TEIE to 0) before making a module stop mode, software standby mode, watch mode, subactive mode, or subsleep mode transition. TSR, TDR, and SSR are reset. The output pin states in module stop mode, software standby mode, watch mode, subactive mode, or subsleep mode depend on the port settings, and becomes high-level output after the relevant mode is cleared. If a transition is made during transmission, the data being transmitted will be undefined. When transmitting without changing the transmit mode after the relevant mode is cleared, transmission can be started by setting TE to 1 again, and performing the following sequence:

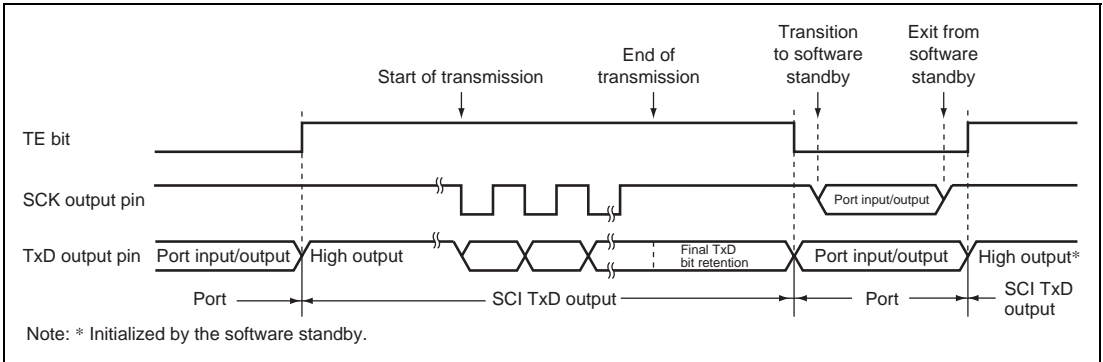
SSR read -> TDR write -> TDRE clearance. To transmit with a different transmit mode after clearing the relevant mode, the procedure must be started again from initialization. Figure 12.39 shows a sample flowchart for mode transition during transmission. Port pin states are shown in figures 12.40 and 12.41.



**Figure 12.39 Sample Flowchart for Mode Transition during Transmission**



**Figure 12.40 Port Pin State of Asynchronous Transmission Using Internal Clock**



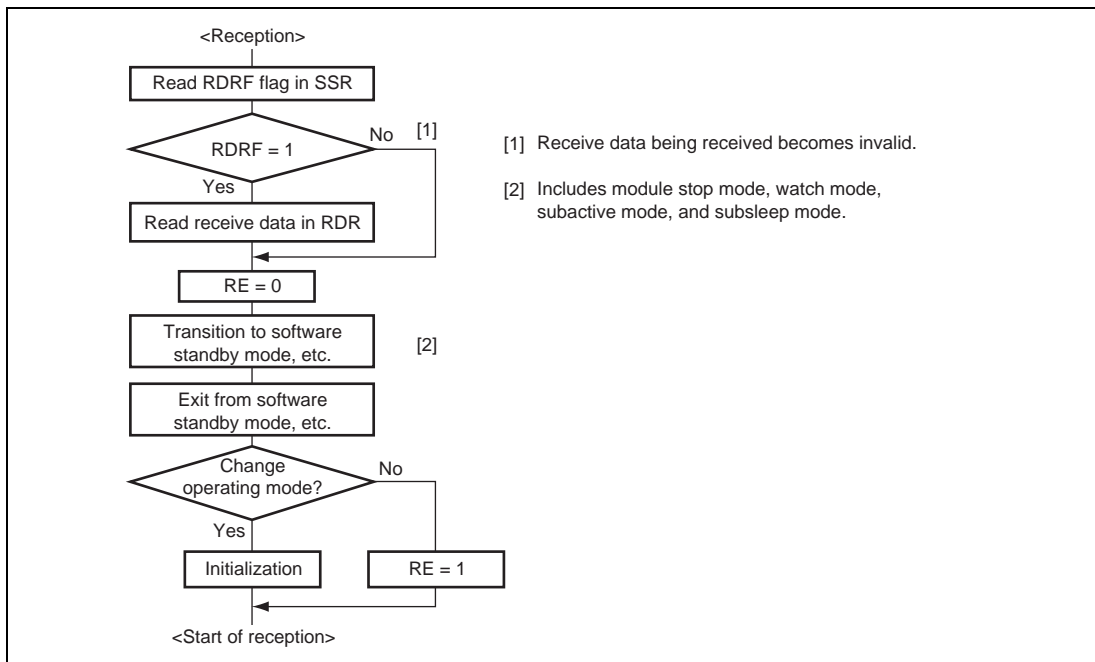
**Figure 12.41 Port Pin State of Synchronous Transmission Using Internal Clock**

- Reception

Receive operation should be stopped (by clearing RE to 0) before making a module stop mode, software standby mode, watch mode, subactive mode, or subsleep mode transition. RSR, RDR, and SSR are reset. If a transition is made without stopping operation, the data being received will be invalid.

To continue receiving without changing the reception mode after the relevant mode is cleared, set RE to 1 before starting reception. To receive with a different receive mode, the procedure must be started again from initialization.

Figure 12.42 shows a sample flowchart for mode transition during reception.

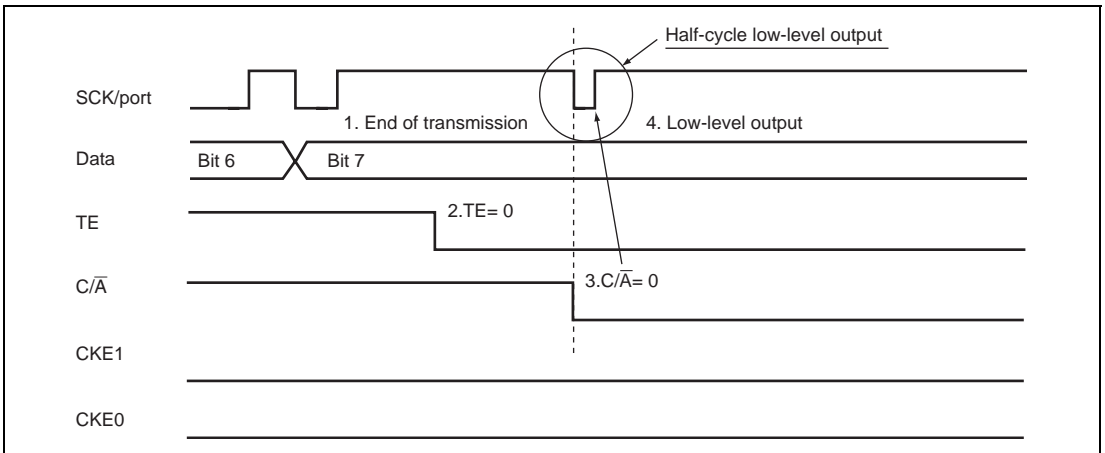


**Figure 12.42 Sample Flowchart for Mode Transition during Reception**

### 12.10.7 Switching from SCK Pin Function to Port Pin Function:

When switching the SCK pin function to the output port function (high-level output) by making the following settings while  $DDR = 1$ ,  $DR = 1$ ,  $C/\bar{A} = 1$ ,  $CKE1 = 0$ ,  $CKE0 = 0$ , and  $TE = 1$  (synchronous mode), low-level output occurs for one half-cycle.

1. End of serial data transmission
2.  $TE$  bit = 0
3.  $C/\bar{A}$  bit = 0 ... switchover to port output
4. Occurrence of low-level output (see figure 12.43)

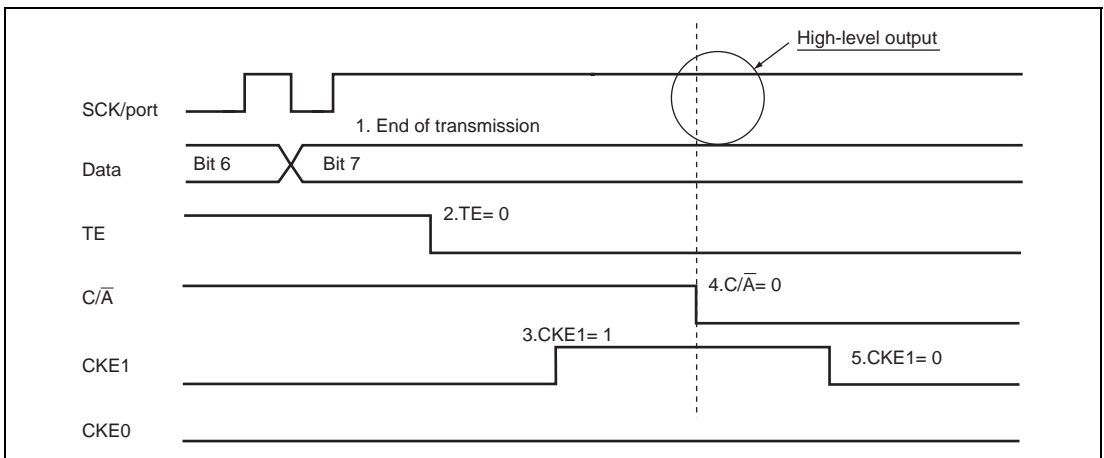


**Figure 12.43 Operation when Switching from SCK Pin Function to Port Pin Function**

**Sample Procedure for Avoiding Low-Level Output:** As this sample procedure temporarily places the SCK pin in the input state, the SCK/port pin should be pulled up beforehand with an external circuit.

With  $DDR = 1$ ,  $DR = 1$ ,  $C/\bar{A} = 1$ ,  $CKE1 = 0$ ,  $CKE0 = 0$ , and  $TE = 1$ , make the following settings in the order shown.

1. End of serial data transmission
2. TE bit = 0
3. CKE1 bit = 1
4.  $C/\bar{A}$  bit = 0 ... switchover to port output
5. CKE1 bit = 0



**Figure 12.44 Operation when Switching from SCK Pin Function to Port Pin Function  
(Example of Preventing Low-Level Output)**

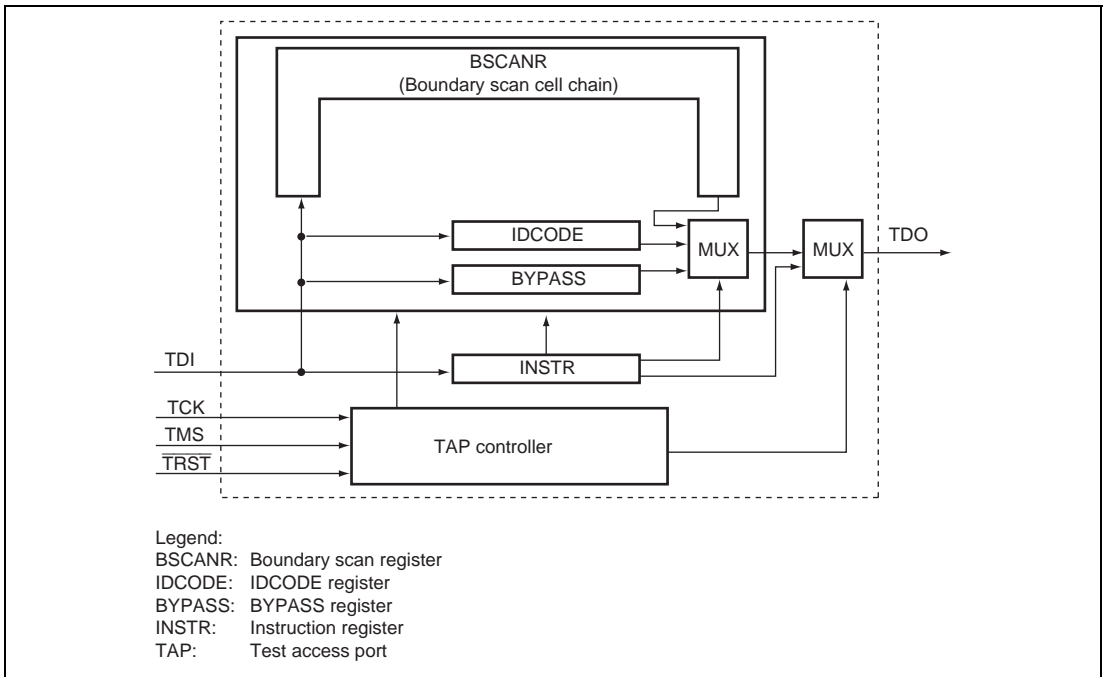


## Section 13 Boundary Scan Function

The HD64F2218, HD64F2218U, HD64F2218CU and HD64F2217CU incorporate a boundary scan function, which is a serial I/O interface based on the JTAG (Joint Test Action Group, IEEEStd.1149.1 and IEEE Standard Test Access Port and Boundary Scan Architecture). Figure 13.1 shows the block diagram of the boundary scan function.

### 13.1 Features

- Five test signals
  - TCK, TDI, TDO, TMS,  $\overline{\text{TRST}}$
- Six test modes supported
  - BYAPASS, SAMPLE/PRELOAD, EXTEST, CLAMP, HIGHZ, IDCODE
- Boundary scan function cannot be performed on the following pins.
  - Power supply pins: VCC, VSS, Vref, PLLVCC, PLLVSS, DrVCC, DrVSS
  - Clock signals: EXTAL, XTAL, OSC2, OSC1
  - Analog signals: P40 to P43, P96, P97, USD+, USD-
  - Boundary scan signals: TCK, TDI, TDO, TMS,  $\overline{\text{TRST}}$
  - H-UDI control signal: EMLE



**Figure 13.1 Block Diagram of Boundary Scan Function**

## 13.2 Pin Configuration

Table 13.1 shows the I/O pins used in the boundary scan function.

**Table 13.1 Pin Configuration**

Pin Name	I/O	Function
TMS	Input	<p>Test Mode Select</p> <p>Controls the TAP controller which is a 16-state Finite State Machine.</p> <p>The TMS input value at the rising edge of TCK determines the status transition direction on the TAP controller.</p> <p>The TMS is fixed high when the boundary scan function is not used.</p> <p>The protocol is based on JTAG standard (IEEE Std.1149.1).</p> <p>This pin has a pull-up resistor.</p>
TCK	Input	<p>Test Clock</p> <p>A clock signal for the boundary scan function.</p> <p>When the boundary scan function is used, input a clock of 50% duty to this pin.</p> <p>This pin has a pull-up resistor.</p>
TDI	Input	<p>Test Data Input</p> <p>A data input signal for the boundary scan function.</p> <p>Data input from the TDI is latched at the rising edge of TCK.</p> <p>TDI is fixed high when the boundary scan function is not used.</p> <p>This pin has a pull-up register.</p>
TDO	Output	<p>Test Data Output</p> <p>A data output signal for the boundary scan function. Data output from the TDO changes at the falling edge of TCK. The output driver of the TDO is driven only when it is necessary only in Shift-IR or Shift-DR states, and is brought to the high-impedance state when not necessary.</p>
$\overline{\text{TRST}}$	Input	<p>Test Reset</p> <p>Asynchronously resets the TAP controller when <math>\overline{\text{TRST}}</math> is brought low.</p> <p>The user must apply power-on reset signal specific to the boundary scan function when the power is supplied. (For details on signal design, refer to section 13.5, Usage Notes.)</p> <p>This pin has a pull-up resistor.</p>

## 13.3 Register Descriptions

The boundary scan function has the following registers. These registers cannot be accessed by the CPU.

- Instruction register (INSTR)
- IDCODE register (IDCODE)
- BYPASS register (BYPASS)
- Boundary scan register (BSCANR)

### 13.3.1 Instruction Register (INSTR)

INSTR is a 3-bit register. At initialization, this register is specified to IDCODE mode. When TRST is pulled low, or when the TAP controller is in the Test-Logic-Reset state, INSTR is initialized. INSTR can be written by the serial data input from the TDI. If more than three bits of instruction is input from the TDI, INSTR stores the last three bits of serial data.

If a command reserved in INSTR is used, the correct operation cannot be guaranteed.

Bit	Bit Name	Initial Value	R/W	Description
2	TI2	1	—	Test Instruction Bits
1	TI1	0	—	Instruction configuration is shown in table 13.2.
0	TI0	1	—	

**Table 13.2 Instruction Configuration**

Bit 2	Bit1	Bit 0	
TI2	TI1	TI0	Instruction
0	0	0	EXTEST
0	0	1	SAMPLE/PRELOAD
0	1	0	CLAMP
0	1	1	HIGHZ
1	0	0	Reserved
1	0	1	IDCODE (initial value)
1	1	0	Reserved
1	1	1	BYPASS

**EXTEST:** The EXTEST instruction is used to test external circuits when this LSI is installed on the print circuit board. If this instruction is executed, output pins are used to output test data (specified by the SAMPLE/PRELOAD instruction) from the boundary scan register to the print circuit board, and input pins are used to input test results.

**SAMPLE/PRELOAD:** The SAMPLE/PRELOAD instruction is used to input data from the LSI internal circuits to the boundary scan register, output data from scan path, and reload the data to the scan path. While this instruction is executed, input signals are directly input to the LSI and output signals are also directly output to the external circuits. The LSI system circuit is not affected by this instruction.

In SAMPLE operation, the boundary scan register latches the snap shot of data transferred from input pins to internal circuit or data transferred from internal circuit to output pins. The latched data is read from the scan path. The scan register latches the snap data at the rising edge of the TCK in Capture-DR state. The scan register latches snap shot without affecting the LSI normal operation.

In PRELOAD operation, initial value is written from the scan path to the parallel output latch of the boundary scan register prior to the EXTEST instruction execution. If the EXTEST is executed without executing this RELOAD operation, undefined values are output from the beginning to the end (transfer to the output latch) of the EXTEST sequence. (In EXTEST instruction, output parallel latches are always output to the output pins.)

**CLAMP:** When the CLAMP instruction is selected output pins output the boundary scan register value which was specified by the SAMPLE/PRELOAD instruction in advance. While the CLAMP instruction is selected, the status of boundary scan register is maintained regardless of the TAP controller state. BYPASS is connected between TDI and TDO, the same operation as BYPASS instruction can be achieved.

**HIGHZ:** When the HIGHZ instruction is selected, all outputs enter high-impedance state. While this instruction is selected, the status of boundary scan register is maintained regardless of the TAP controller state. BYPASS resistor is connected between TDI and TDO, the same operation as BYPASS instruction can be achieved.

**IDCODE:** When the IDCODE instruction is selected, IDCODE register value is output to the TDO in Shift-DR state of TAP controller. In this case, IDCODE register value is output from the LSB. During this instruction execution, test circuit does not affect the system circuit. INSTR is initialized by the IDCODE instruction in Test-Logic-Reset state of TAP controller.

**BYPASS:** The BYPASS instruction is a standard instruction necessary to operate bypass register. The BYPASS instruction improves the serial data transfer speed by bypassing the scan path. During this instruction execution, test circuit does not affect the system circuit.

### 13.3.2 IDCODE Register (IDCODE)

IDCODE register is a 32-bit register. If INSTR is set to IDCODE mode, IDCODE is connected between TDI and TDO. The HD64F2218, HD64F2218U, HD64F2218CU and HD64F2217CU output fixed codes H'002A200F from the TDO. Serial data cannot be written to IDCODE register through TDI. Table 13.3 shows the IDCODE register configuration.

**Table 13.3 IDCODE Register Configuration**

Bits	31 to 28	27 to 12	11 to 1	0
HD64F2218, HD64F2218U, HD64F2218CU and HD64F2217CU codes	0000	0000 0010 1010 0010	0000 0000 111	1
Contents	Version (4 bits)	Part No. (16 bits)	Product No. (11 bits)	Fixed code (1 bit)

### 13.3.3 BYPASS Register (BYPASS)

BYPASS is a 1-bit register. If INSTR is specified to BYPASS mode, CLAMP mode, or HIGHZ mode, BYPASS is connected between TDI and TDO.

### 13.3.4 Boundary Scan Register (BSCANR)

BSCAN is a 199-bit shift register assigned on the pins to control input/output pins.

The I/O pins consists of three bits (IN, Control, OUT), input pins 1 bit (IN), and output pins 1 bit (OUT) of shift registers. The boundary scan test based on the JTAG standard can be performed by using instructions listed in table 13.2. Table 13.4 shows the correspondence between the LSI pins and boundary scan registers. (In table 13.4, Control indicates the high active pin. By specifying Control to high, the pin is driven by OUT. ) Figure 13.2 shows the boundary scan register configuration example.

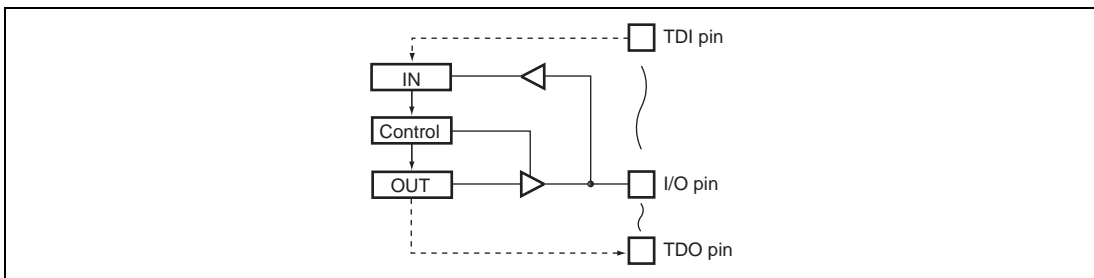


Figure 13.2 Boundary Scan Register Configuration

Table 13.4 Correspondence between LSI Pins and Boundary Scan Register

TFP-100G TFP-100GV Pin No.	BP-112 BP-112V Pin No.	Pin Name	I/O	Bit Name
From TDI				
89	A6	PF7/ $\phi$	IN	198
			Control	197
			OUT	196
91	D6	PF6/ $\overline{AS}$	IN	195
			Control	194
			OUT	193
92	A5	PF5/ $\overline{RD}$	IN	192
			Control	191
			OUT	190
93	B5	PF4/ $\overline{HWR}$	IN	189
			Control	188
			OUT	187
94	C5	PF3/ $\overline{LWR/ADTRG/IRQ3}$	IN	186
			Control	185
			OUT	184
95	A4	PF2/ $\overline{WAIT}$	IN	183
			Control	182
			OUT	181

TFP-100G TFP-100GV Pin No.	BP-112 BP-112V Pin No.	Pin Name	I/O	Bit Name
96	D5	PF1/BACK	IN	180
			Control	179
			OUT	178
97	B4	PF0/BREQ/IRQ2	IN	177
			Control	176
			OUT	175
98	A3	PA3/A19/SCK2	IN	174
			Control	173
			OUT	172
99	C4	PA2/A18/RxD2	IN	171
			Control	170
			OUT	169
100	B3	PA1/A17/TxD2	IN	168
			Control	167
			OUT	166
1	B2	PA0/A16	IN	165
			Control	164
			OUT	163
2	B1	P10/TIOCA0/A20	IN	162
			Control	161
			OUT	160
3	D4	P11/TIOCB0/A21	IN	159
			Control	158
			OUT	157
4	C2	P12/TIOCC0/TCLKA/A22	IN	156
			Control	155
			OUT	154
5	C1	P13/TIOCD0/TCLKB/A23	IN	153
			Control	152
			OUT	151



TFP-100G TFP-100GV Pin No.	BP-112 BP-112V Pin No.	Pin Name	I/O	Bit Name
6	D3	P14/TIOCA1/IRQ0	IN	150
			Control	149
			OUT	148
7	D2	P15/TIOCB1/TCLKC	IN	147
			Control	146
			OUT	145
8	D1	P16/TIOCA2/IRQ1	IN	144
			Control	143
			OUT	142
9	E4	P17/TIOCB2/TCLKD	IN	141
			Control	140
			OUT	139
10	E3	PC0/A0	IN	138
			Control	137
			OUT	136
11	E1	PC1/A1	IN	135
			Control	134
			OUT	133
12	E2	PC2/A2	IN	132
			Control	131
			OUT	130
13	F3	PC3/A3	IN	129
			Control	128
			OUT	127
14	F1	MD0	IN	126
15	F2	MD1	IN	125
16	F4	MD2	IN	124
17	G1	PC4/A4	IN	123
			Control	122
			OUT	121

TFP-100G TFP-100GV Pin No.	BP-112 BP-112V Pin No.	Pin Name	I/O	Bit Name
18	G2	PC5/A5	IN	120
			Control	119
			OUT	118
19	G3	PC6/A6	IN	117
			Control	116
			OUT	115
20	H1	PC7/A7	IN	114
			Control	113
			OUT	112
21	G4	USPND/TMOW	OUT	111
22	H2	P30/TxD0	IN	110
			Control	109
			OUT	108
23	J1	P31/RxD0	IN	107
			Control	106
			OUT	105
24	H3	P32/SCK0/ $\overline{\text{IRQ4}}$	IN	104
			Control	103
			OUT	102
25	J2	PG1/ $\overline{\text{CS3}}$ / $\overline{\text{IRQ7}}$	IN	101
			Control	100
			OUT	99
26	K2	PG2/ $\overline{\text{CS2}}$	IN	98
			Control	97
			OUT	96
27	L2	PG3/ $\overline{\text{CS1}}$	IN	95
			Control	94
			OUT	93
28	H4	PG4/ $\overline{\text{CS0}}$	IN	92
			Control	91
			OUT	90

TFP-100G TFP-100GV Pin No.	BP-112 BP-112V Pin No.	Pin Name	I/O	Bit Name
29	K3	VBUS	IN	89
30	L3	P36	IN	88
			Control	87
			OUT	86
37	K5	PB0/A8	IN	85
			Control	84
			OUT	83
38	J6	PB1/A9	IN	82
			Control	81
			OUT	80
39	L6	PB2/A10	IN	79
			Control	78
			OUT	77
40	K6	PB3/A11	IN	76
			Control	75
			OUT	74
47	L9	UBPM	IN	73
49	K9	PB4/A12	IN	72
			Control	71
			OUT	70
50	L10	PB5/A13	IN	69
			Control	68
			OUT	67
51	K10	PB6/A14	IN	66
			Control	65
			OUT	64
52	K11	PB7/A15	IN	63
			Control	62
			OUT	61

TFP-100G TFP-100GV Pin No.	BP-112 BP-112V Pin No.	Pin Name	I/O	Bit Name
55	H9	P74/MRES	IN	60
			Control	59
			OUT	58
56	H10	P71/ $\overline{\text{CS5}}$	IN	57
			Control	56
			OUT	55
57	H11	$\overline{\text{STBY}}$	IN	54
58	G8	$\overline{\text{RES}}$	IN	53
63	F11	P70/ $\overline{\text{CS4}}$	IN	52
			Control	51
			OUT	50
64	F10	PE0/D0	IN	49
			Control	48
			OUT	47
65	F8	PE1/D1	IN	46
			Control	45
			OUT	44
66	E11	PE2/D2	IN	43
			Control	42
			OUT	41
67	E10	PE3/D3	IN	40
			Control	39
			OUT	38
68	E9	PE4/D4	IN	37
			Control	36
			OUT	35
69	D11	PE5/D5	IN	34
			Control	33
			OUT	32

TFP-100G TFP-100GV Pin No.	BP-112 BP-112V Pin No.	Pin Name	I/O	Bit Name
70	E8	PE6/D6	IN	31
			Control	30
			OUT	29
71	D10	PE7/D7	IN	28
			Control	27
			OUT	26
72	C11	PD0/D8	IN	25
			Control	24
			OUT	23
73	D9	PD1/D9	IN	22
			Control	21
			OUT	20
74	C10	PD2/D10	IN	19
			Control	18
			OUT	17
75	B11	PD3/D11	IN	16
			Control	15
			OUT	14
76	B10	PD4/D12	IN	13
			Control	12
			OUT	11
77	A10	PD5/D13	IN	10
			Control	9
			OUT	8
78	D8	PD6/D14	IN	7
			Control	6
			OUT	5
79	B9	PD7/D15	IN	4
			Control	3
			OUT	2

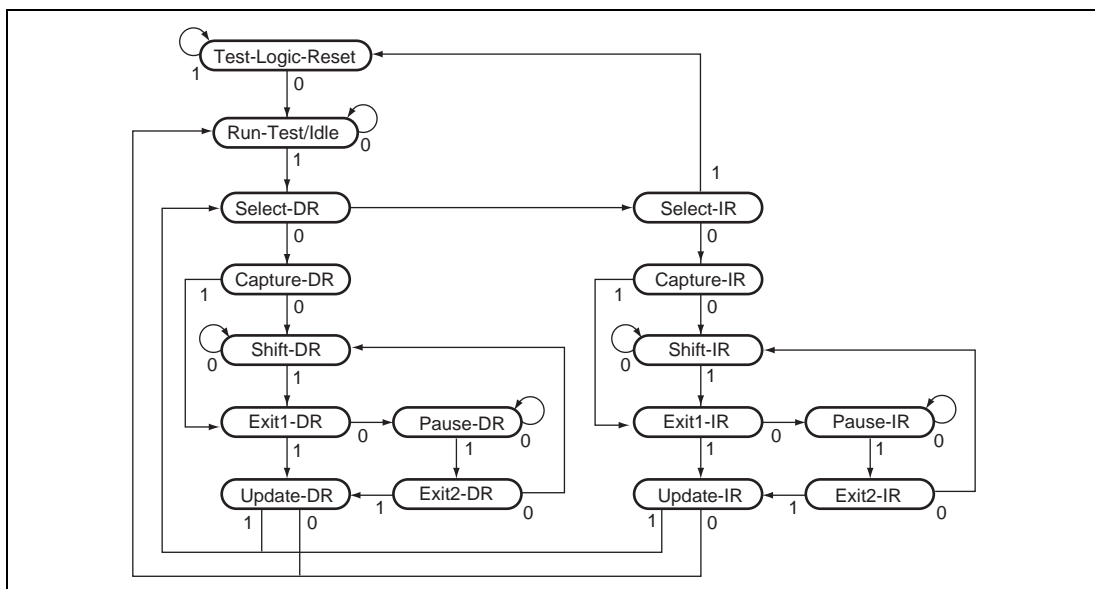
TFP-100G TFP-100GV Pin No.	BP-112 BP-112V Pin No.	Pin Name	I/O	Bit Name
80	A9	FWE	IN	1
81	C8	NMI	IN	0

to TDO

## 13.4 Boundary Scan Function Operation

### 13.4.1 TAP Controller

Figure 13.3 shows the TAP controller status transition diagram, based on the JTAG standard.

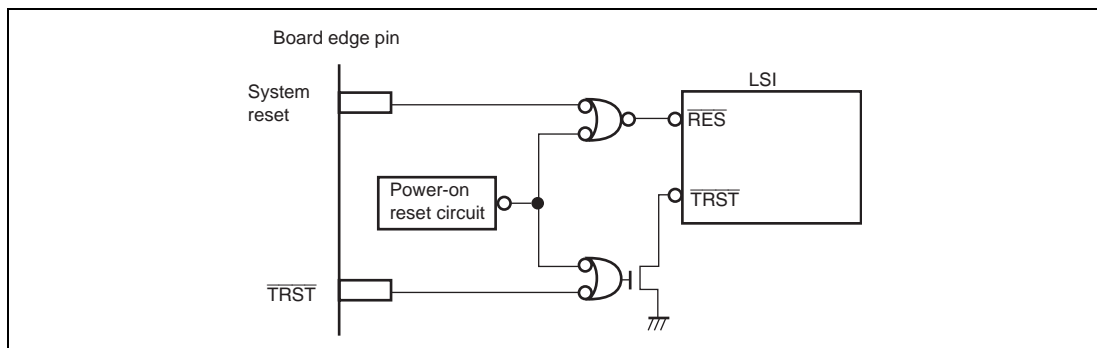


**Figure 13.3 TAP Controller Status Transition**

Note: The transition condition is the TMS value at the rising edge of TCK. The TDI value is sampled at the rising edge of the TCK and shifted at the falling edge of the TCK. The TDO value changes at the falling edge of the TCK. In addition, TDO is high-impedance state in a state other than Shift-DR or Shift-IR state. If  $\overline{TRST}$  is 0, Test-Logic-Reset state is entered asynchronously with the TCK.

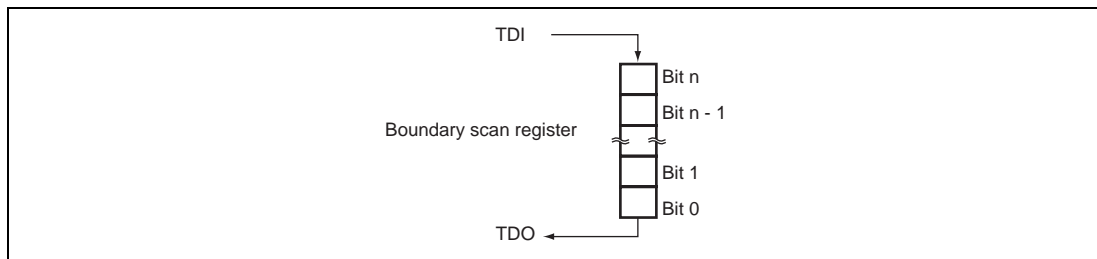
## 13.5 Usage Notes

- When using the boundary scan function, clear  $\overline{\text{TRST}}$  to 0 at power-on and after the  $t_{\text{RESW}}$  time has elapsed set  $\overline{\text{TRST}}$  to 1 and set TCK, TMS, and TDI appropriately. During normal operation when the boundary scan function is not used, set TCK, TMS, and TDI to Hi-Z, clear  $\overline{\text{TRST}}$  to 0 at power-on, and after the  $t_{\text{RESW}}$  time has elapsed set  $\overline{\text{TRST}}$  to 1 or to Hi-Z. These pins are pulled up internally, so care must be taken in standby mode because breakthrough current flow can occur if there is a potential difference between the pin input voltage value when set to 1 and the power supply voltage  $V_{\text{cc}}$ .
- The following must be noted on the power-on reset signal applied to the  $\overline{\text{TRST}}$  pin.
  - Reset signal must be applied at power-on.
  - $\overline{\text{TRST}}$  must be separated in order not to affect the system operation.
  - $\overline{\text{TRST}}$  must be separated from the system circuitry in order not to affect the system operation.
  - System circuitry must also be separated from the  $\overline{\text{TRST}}$  in order not to affect  $\overline{\text{TRST}}$  operation as shown in figure 13.4.



**Figure 13.4 Recommended Reset Signal Design**

- TCK clock speed should be slower than system clock frequency.
- In serial communication, data is input or output from the LSB as shown in figure 13.5.



**Figure 13.5 Serial Data Input/Output**

5. If a pin with pull-up function is SAMPLEed with pull-up function enabled, the corresponding IN register is set to 1. In this case, the corresponding Control register must be cleared to 0.
6. If a pin with open-drain function is SAMPLEed while its open-drain function is enabled and while the corresponding OUT register is set to 1, the corresponding Control register is cleared to 0 (the pin status is Hi-Z). If the pin is SAMPLEed while the corresponding OUT register is cleared to 0, the corresponding Control register is set to 1 (the pin status is 0).
7. If EXTEST, CLAMP, or HIGHZ state is entered, this LSI enters guarded mode such as hardware standby mode ( $\overline{\text{RES}} = \overline{\text{STBY}} = 0$ ). Before entering normal operating mode from EXTEST, CLAMP, or HIGHZ state, specify  $\overline{\text{RES}}$ ,  $\overline{\text{STBY}}$ , FWE, and MD2 to MD0 pin to the designated mode.
8. The EMLE pin must be cleared to 0. When the pin is set to 1, this chip functions as High-performance user debugging interface (H-UDI).

EMLE Pin	Chip State
0	Normal operation, boundary scan function
1	High-performance user debugging interface (H-UDI)

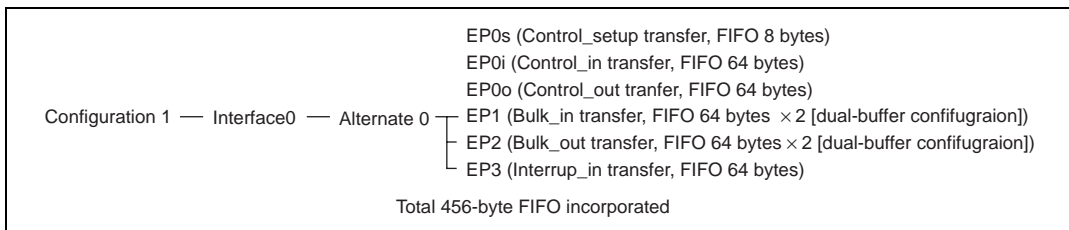


## Section 14 Universal Serial Bus (USB)

This LSI incorporates a USB function module complying with USB standard version 1.1. Figure 14.1 shows the block diagram of the USB.

### 14.1 Features

- USB standard version 2.0 full speed mode (12 Mbps) support
- Bus-powered mode or self-powered mode is selectable via the USB specific pin ( $\overline{\text{UBPM}}$ )
- On-chip PLL circuit to generate the USB operation clock ( $24 \text{ MHz} \times 2 = 48 \text{ MHz}$ ,  $16 \text{ MHz} \times 3 = 48 \text{ MHz}$ )
- On-chip bus transceiver
- Standard commands are processed automatically by hardware
  - Only Set\_Descriptor, Get\_Descriptor, Class/VendorCommand, and SynchFrame commands should be processed by software
- Current Configuration value can be checked by Set\_Configuration interrupt
- Three transfer modes supported (Control, Bulk, Interrupt)
- Configuration of four endpoints; EP0, EP1, EP2, and EP3



- 16 kinds of interrupts
  - Suspend/resume interrupt source can be assigned for  $\overline{\text{IRQ6}}$
  - Each interrupt source except the suspend/resume interrupt source can be assigned for  $\overline{\text{EXIRQ0}}$  or  $\overline{\text{EXIRQ1}}$  via registers
- DMA transfer interface
  - DMA transfer is enabled for the Bulk transfer data of EP1 and EP2
- 8-bit bus (3 cycle access timing) connected to the external bus interface
  - Internal registers are addressed to a part of area 6 of external address (H'C00000 to H'DFFFFFF)
  - Address H'C00100 to H'DFFFFFF is for USB reserved area and thus access prohibited.

Note: In this section, power-down mode represents watch, subactive, subsleep, and software standby modes.

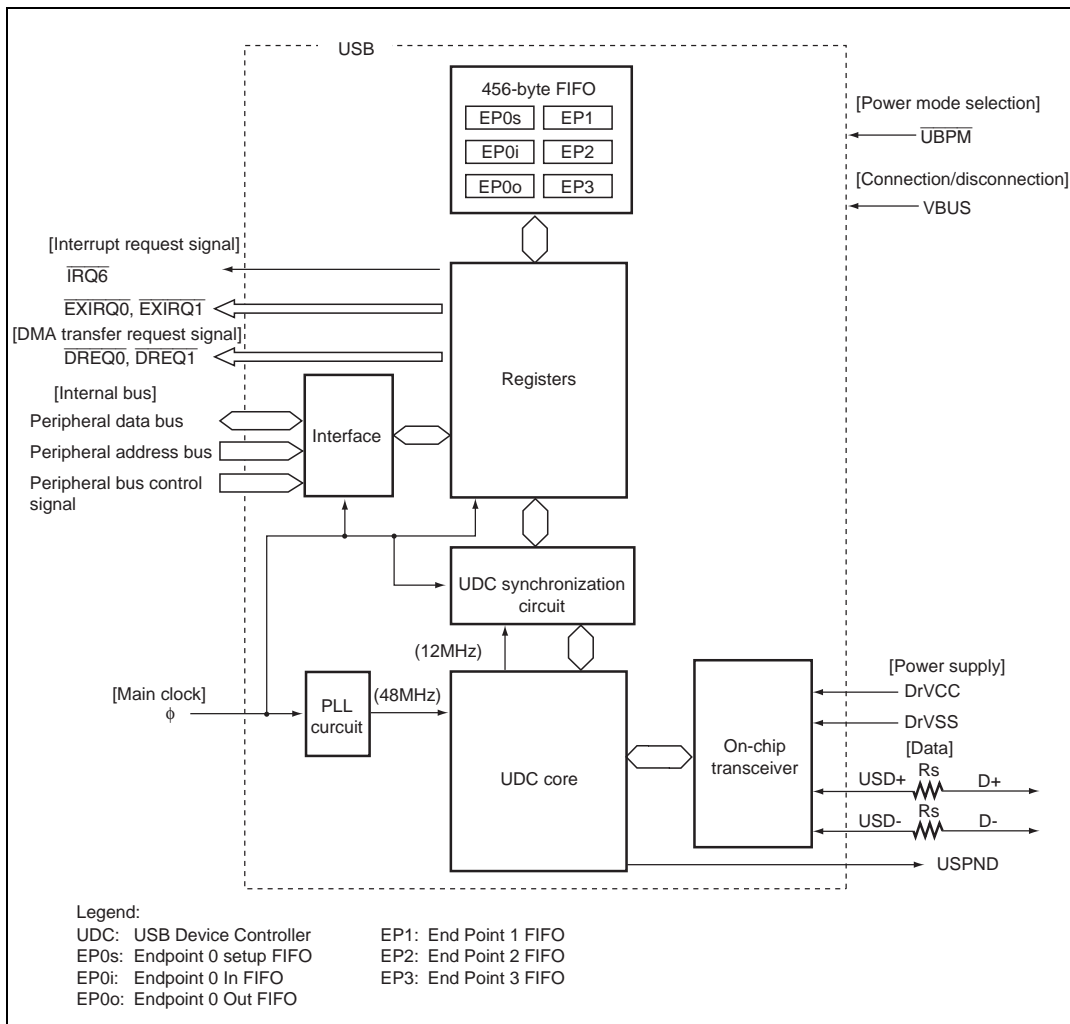


Figure 14.1 Block Diagram of USB

## 14.2 Input/Output Pins

Table 14.1 shows the USB pin configuration.

**Table 14.1 Pin Configuration**

Pin Name	I/O	Function
USD+	I/O	I/O pin for USB data
USD-		
DrVCC	Input	USB internal transceiver power supply pin
DrVSS	Input	USB internal transceiver ground pin
VBUS	Input	USB cable connection/disconnection detection signal pin
UBPM	Input	USB bus-powered/self-powered mode set pin When USB is used in bus-powered mode, $\overline{\text{UBPM}}$ must be fixed low. When USB is used in self-powered mode, $\overline{\text{UBPM}}$ must be fixed high.
USPND	Output	USB suspend output pin When USB enters the suspend state, USPND is set to high.

## 14.3 Register Descriptions

The USB has the following registers.

- USB control register (UCTLR)
- USB DMAC transfer request register (UDMAR)
- USB device resume register (UDRR)
- USB trigger register 0 (UTRG0)
- USB FIFO clear register 0 (UFCLR0)
- USB endpoint stall register 0 (UESTL0)
- USB endpoint stall register 1 (UESTL1)
- USB endpoint data register 0s (UEDR0s) [for Setup data reception]
- USB endpoint data register 0i (UEDR0i) [for Control\_in data transmission]
- USB endpoint data register 0o (UEDR0o) [for Control\_out data reception]
- USB endpoint data register 3 (UEDR3) [for Interrupt\_in data transmission]
- USB endpoint data register 1 (UEDR1) [for Bulk\_in data transmission]
- USB endpoint data register 2 (UEDR2) [for Bulk\_out data reception]
- USB endpoint receive data size register 0o (UESZ0o) [for Control\_out data reception]
- USB endpoint receive data size register 2 (UESZ2) [for Bulk\_out data reception]

- USB interrupt flag register 0 (UIFR0)
- USB interrupt flag register 1 (UIFR1)
- USB interrupt flag register 3 (UIFR3)
- USB interrupt enable register 0 (UIER0)
- USB interrupt enable register 1 (UIER1)
- USB interrupt enable register 3 (UIER3)
- USB interrupt select register 0 (UISR0)
- USB interrupt select register 1 (UISR1)
- USB interrupt select register 3 (UISR3)
- USB data status register (UDSR)
- USB Configuration value register (UCVR)
- USB test register 0 (UTSTR0)
- USB test register 1 (UTSTR1)
- USB test registers 2 and A to F (UTSTR2, UTSTRA to UTSTRF)
- Module stop control register B (MSTPCRB)
- Extended module stop register (EXMDLSTP)

### 14.3.1 USB Control Register (UCTLR)

UCTLR is used to select the USB operation clock and control the USB module internal reset. UCTLR can be read from or written to even when the USB module stop 2 bit (MSTPB0) in MSTPCRB is 1. For details on UCTLR setting procedure, refer to section 14.5, Communication Operation.

Bit	Bit Name	Initial Value	R/W	Description
7	—	0	R/W	Reserved The write value should always be 0.
6	TMOWE	0	R/W	TMOW Pin Enable 0: The USPND/TMOW pin outputs USPND of USB. 1: The USPND/TMOW pin outputs TMOW of RTC.

Bit	Bit Name	Initial Value	R/W	Description
5	UCKS3	0	R/W	USB Operation Clock Select 3 to 0
4	UCKS2			<p>These bits control the on-chip PLL, which generates the USB operation clock (48 MHz). When UCKS3 to UCKS0 are 0000, the PLL circuit stops and thus the USB operation clock must be selected according to the clock source.</p> <p>The on-chip PLL circuit starts operating after the USB module stop 2 bit has been cancelled. In addition, the USB operation clock is supplied to the UDC core after the USB operating clock stabilization time has been passed. The completion timing of the USB operating clock stabilization time can be detected by the CK48READY flag in UIFR3.</p> <p>UCKS0 to UCKS3 must be written while the USB module stop 2 bit (MSTPB0) is 1.</p> <p>0000: USB operation clock stops (PLL stops)</p> <p>0001: Reserved</p> <p>001x: Reserved</p> <p>010x: Reserved</p> <p>0110: Uses a clock (48 MHz) generated by doubling the 24-MHz main oscillation by the PLL.</p> <p>0111: Uses a clock (48 MHz) generated by tripling the 16-MHz main oscillation by the PLL.</p> <p>1xxx: Reserved</p> <p>The USB operating clock stabilization time is 2 ms.</p> <p>Legend:</p> <p>x: Don't care</p>
3	UCKS1			
2	UCKS0			

Bit	Bit Name	Initial Value	R/W	Description
1	UIFRST	1	R/W	<p>USB Interface Software Reset</p> <p>Controls USB module internal reset. When the UIFRST bit is set to 1, the USB internal modules other than UCTLR, UIER3, and the CK48READY bit in UIFR3 are all reset. At initialization, the UIFRST bit must be cleared to 0 after the USB operating clock (48 MHz) stabilization time has passed following the clearing of the USB module stop 2 bit.</p> <p>0: Sets the USB internal modules to the operating state. (At initialization, this bit must be cleared after the USB operating clock stabilization time has passed.)</p> <p>1: Sets the USB internal modules other than UCTLR, UIER3, and the CK48READY bit in UIFR3 to the reset state.</p> <p>If the UIFRST bit is set to 1 after it is cleared to 0, the UDCRST bit should also be set to 1 simultaneously.</p>
0	UDCRST	1	R/W	<p>UDC Core Software Reset</p> <p>Controls reset of the UDC core in the USB module. When the UDCRST bit is set to 1, the UDC core is reset and the USB bus synchronization operation stops. At initialization, UDCRST must be cleared to 0 after D+ pull-up by the port (P36) control following the clearing of the UIFRST bit. In the suspend state, to maintain the internal state of the UDC core, enter power-down mode after setting the USB module stop 2 bit with the UDCRST bit to be maintained to 0. After VBUS disconnection detection, UDCRST must be set to 1.</p> <p>0: Sets the UDC core in the USB module to operating state. (At initialization, UDCRST must be cleared to 0 after D+ pull-up by the port control following the clearing of the UIFRST bit.)</p> <p>1: Sets the UDC core in the USB module to reset state. (In the suspend state, UDCRST must not be set to 1; after VBUS disconnection detection, UDCRST must be set to 1.)</p>

### 14.3.2 USB DMAC Transfer Request Register (UDMAR)

UDMAR is set when data transfer by means of a USB request of the on-chip DMAC is performed for data registers UEDR1 and UEDR2 corresponding to EP1 and EP2 respectively used for Bulk transfer. For the DMAC transfer, set  $\overline{\text{DREQ0}}$  and  $\overline{\text{DREQ1}}$  separately. If  $\overline{\text{DREQ0}}$  and  $\overline{\text{DREQ1}}$  usage overlaps, the USB cannot operate correctly. For details on DMAC transfer, refer to section 14.6, DMA Transfer Specifications.

Note: As the  $\overline{\text{DREQ}}$  signal is not used in the data transfer by auto request of the on-chip DMAC, set UDMAR to H'00.

Bit	Bit Name	Initial Value	R/W	Description
7 to 4	—	All 0	R	Reserved These bits are always read as 0 and cannot be modified.
3	EP2T1	0	R/W	EP2 DMAC Transfer Request Select 1, 0
2	EP2T0			00: Does not request EP2 DMAC transfer 01: Reserved 10: Requests EP2 DMAC transfer by $\overline{\text{DREQ0}}$ 11: Requests EP2 DMAC transfer by $\overline{\text{DREQ1}}$
1	EP1T1	0	R/W	EP1 DMAC Transfer Request Select 1, 0
0	EP1T0			00: Does not request EP1 DMAC transfer 01: Reserved 10: Requests EP1 DMAC transfer by $\overline{\text{DREQ0}}$ 11: Requests EP1 DMAC transfer by $\overline{\text{DREQ1}}$

### 14.3.3 USB Device Resume Register (UDRR)

UDRR indicates the enabled or disabled state of remote wakeup by the host, and executes the remote wakeup of the USB modules in the suspend state.

Bit	Bit Name	Initial Value	R/W	Description
7 to 2	—	All 0	R	Reserved These bits are always read as 0 and cannot be modified.
1	RWUPs	0	R	Remote Wakeup Status Indicates the enabled or disabled state of remote wakeup by the host. This bit is a status bit and cannot be written to. If the remote wakeup from the host is disabled by Device_Remote_Wakeup through the Set_Feature/Clear_Feature request, this bit is cleared to 0. If the remote wakeup is enabled, this bit is set to 1. 0: Remote wakeup disabled state 1: Remote wakeup enabled state
0	DVR	0	W	Device Resume Cancels the suspend state (executes the remote wakeup). This bit can be written to 1 and is always read as 0. Before executing the remote wakeup, power-down mode or USB module stop mode must be cancelled to provide a clock for the USB module. 0: Performs no operation 1: Cancels the suspend state (executes the remote wakeup)



### 14.3.4 USB Trigger Register 0 (UTRG0)

UTRG0 is a one-shot register to generate triggers to the FIFO for each endpoint EP0 to EP3. For details, see section 2.9.4, Accessing Registers Containing Write-Only Bits.

Bit	Bit Name	Initial Value	R/W	Description
7, 6	—	All 0	R	Reserved These bits are always read as 0 and cannot be modified.
5	EP2RDFN	0	W	EP2 Read Complete 0: Performs no operation. 1: Writes 1 to this bit after reading data for EP2 OUT FIFO. EP2 has a dual-FIFO configuration. This trigger is generated to the currently effective FIFO.
4	EP1PKTE	0	W	EP1 Packet Enable 0: Performs no operation. 1: Generates a trigger to enable the transmission to EP1 IN FIFO. EP1 has a dual-FIFO configuration. This trigger is generated to the currently effective FIFO.
3	EP3PKTE	0	W	EP3 Packet Enable 0: Performs no operation. 1: Generates a trigger to enable the transmission to EP3 IN FIFO.
2	EP0oRDFN	0	W	EP0o Read Complete 0: Performs no operation. 1: Writes 1 to this bit after reading data for EP0o OUT FIFO. This trigger enables EP0o to receive the next packet.
1	EP0iPKTE	0	W	EP0i Packet Enable 0: Performs no operation. 1: Generates a trigger to enable the transmission to EP0i IN FIFO.

Bit	Bit Name	Initial Value	R/W	Description
0	EP0sRDFN	0	W	<p>EP0s Read Complete</p> <p>0: Performs no operation. A NAK handshake is returned in response to transmit/receive requests in the data stage until 1 is written to this bit.</p> <p>1: Writes 1 to this bit after reading data for EP0s command FIFO. After receiving the setup command, this trigger enables the next packet in the data stage to be received by EP0i and EP0o. EP0s can always be overwritten and receive data regardless of this trigger.</p>

---

### 14.3.5 USB FIFO Clear Register 0 (UFCLR0)

UFCLR0 is a one-shot register used to clear the FIFO for each endpoint EP0 to EP3. Writing 1 to a bit clears the data in the corresponding FIFO.

For IN FIFO, writing 1 to a bit in UFCLR0 clears the data for which the corresponding PKTE bit in UTRG0 is not set to 1 after data write, or data that is validated by setting the corresponding PKTE bit in UTRG0.

For OUT FIFO, writing 1 to a bit in UFCLR0 clears data that has not been fixed during reception or received data for which the corresponding RDFN bit is not set to 1. Accordingly, care must be taken not to clear data that is currently being received or transmitted. EP1 and EP2, having a dual-FIFO configuration, are cleared by entire FIFOs. Note that this trigger does not clear the corresponding interrupt flag. For details, see section 2.9.4, Accessing Registers Containing Write-Only Bits.

Bit	Bit Name	Initial Value	R/W	Description
7, 6	—	All 0	R	Reserved These bits are always read as 0 and cannot be modified.
5	EP2CLR	0	W	EP2 Clear* 0: Performs no operation. 1: Clears EP2 OUT FIFO.
4	EP1CLR	0	W	EP1 Clear 0: Performs no operation. 1: Clears EP1 IN FIFO.
3	EP3CLR	0	W	EP3 Clear 0: Performs no operation. 1: Clears EP3 IN FIFO.
2	EP0oCLR	0	W	EP0o Clear 0: Performs no operation. 1: Clears EP0o OUT FIFO.
1	EP0iCLR	0	W	EP0i Clear 0: Performs no operation. 1: Clears EP0i IN FIFO.

Bit	Bit Name	Initial Value	R/W	Description
0	—	0	R	Reserved This bit is always read as 0 and cannot be modified.

Note:\* When DMA writes are enabled (EP2T1 set to 1 and EP2T0 set to 0 or 1 in UDMAR), it is not possible to clear the data in the FIFO by writing 1 to EP2CLR. To clear the data in the FIFO, disable DMA transfers (clear EP2T1 and EP2T0 in UDMAR to 0) and then write 1 to EP2CLR.

### 14.3.6 USB Endpoint Stall Register 0 (UESTL0)

UESTL0 is used to forcibly stall each endpoint EP0 to EP3. When the bit is set to 1, the corresponding endpoint returns a stall handshake to the host, following from the next transfer.

The stall bit for endpoint 0 is cleared automatically on reception of 8-byte command data for which decoding is performed by the function, and thus the EPOSTL bit is cleared to 0. When the SetupTS flag in UIFR0 is set to 1, a write of 1 to the EPOSTL bit is ignored. For details, refer to section 14.5.9, Stall Operations.

Bit	Bit Name	Initial Value	R/W	Description
7, 6	—	All 0	R	Reserved These bits are always read as 0 and cannot be modified.
5	EP2STL	0	R/W	EP2 Stall 0: Cancels the EP2 stall state. 1: Sets the EP2 stall state.
4	EP1STL	0	R/W	EP1 Stall 0: Cancels the EP1 stall state. 1: Sets the EP1 stall state.
3	EP3STL	0	R/W	EP3 Stall 0: Cancels the EP3 stall state. 1: Sets the EP3 stall state.
2, 1	—	All 0	R	Reserved These bits are always read as 0 and cannot be modified.
0	EPOSTL	0	R/W	EP0 Stall 0: Cancels the EP0 stall state. 1: Sets the EP0 stall state.

### 14.3.7 USB Endpoint Stall Register 1 (UESTL1)

UESTL1 is used to control stall cancellation mode for all endpoints.

Bit	Bit Name	Initial Value	R/W	Description
7	SCME	0	R/W	Reserved The write value should always be 0.
6 to 0	—	All 0	R	Reserved These bits are always read as 0 and cannot be modified.

### 14.3.8 USB Endpoint Data Register 0s (UEDR0s)

UEDR0s stores the setup command for endpoint 0 (for Control\_out transfer). UEDR0s stores 8-byte command data sent from the host in setup stage.

For details on the USB operation when data for the next setup stage is received while data in UEDR0s is being read, refer to section 14.8, Usage Notes.

UEDR0s is a byte register to which 4-byte address area is assigned. Accordingly, UEDR0s allows the user to read 2-byte or 4-byte data continuously by word transfer or longword transfer.

Bit	Bit Name	Initial Value	R/W	Description
7 to 0	D7 to D0	—	R	These bits store the setup command for Control_out transfer

### 14.3.9 USB Endpoint Data Register 0i (UEDR0i)

UEDR0i is a data register for endpoint 0 (for Control\_in transfer). UEDR0i stores data to be sent to the host. The number of data items to be written continuously must be the maximum packet size or less.

UEDR0i is a byte register to which 4-byte address area is assigned. Accordingly, UEDR0i allows the user to write 2-byte or 4-byte data continuously by word transfer or longword transfer. For details, see section 2.9.4, Accessing Registers Containing Write-Only Bits.

Bit	Bit Name	Initial Value	R/W	Description
7 to 0	D7 to D0	All 0	W	These bits store data for Control_in transfer

### 14.3.10 USB Endpoint Data Register 0o (UEDR0o)

UEDR0o is a data register for endpoint 0 (for Control\_out transfer). UEDR0o stores data received from the host. The number of data items to be read must be the number of bytes specified by UESZ0o.

When 1 byte is read from UEDR0o, UESZ0o is decremented by 1.

UEDR0o is a byte register to which 4-byte address area is assigned. Accordingly, UEDR0o allows the user to read 2-byte or 4-byte data continuously by word transfer or longword transfer.

Bit	Bit Name	Initial Value	R/W	Description
7 to 0	D7 to D0	—	R	These bits store data for Control_out transfer

### 14.3.11 USB Endpoint Data Register 3 (UEDR3)

UEDR3 is a data register for endpoint 3 (for Interrupt\_in transfer). UEDR3 stores data to be sent to the host. The number of data items to be written continuously must be the maximum packet size or less.

UEDR3 is a byte register to which 4-byte address area is assigned. Accordingly, UEDR3 allows the user to write 2-byte or 4-byte data continuously by word transfer or longword transfer. For details, see section 2.9.4, Accessing Registers Containing Write-Only Bits.

Bit	Bit Name	Initial Value	R/W	Description
7 to 0	D7 to D0	All 0	W	These bits store data for Interrupt_in transfer

### 14.3.12 USB Endpoint Data Register 1 (UEDR1)

UEDR1 is a data register for endpoint 1 (for Bulk\_in transfer). UEDR1 stores data to be sent to the host. The number of data items to be written continuously must be the maximum packet size or less.

UEDR1 is a byte register to which 4-byte address area is assigned. Accordingly, UEDR1 allows the user to write 2-byte or 4-byte data continuously by word transfer or longword transfer. For details, see section 2.9.4, Accessing Registers Containing Write-Only Bits.

Bit	Bit Name	Initial Value	R/W	Description
7 to 0	D7 to D0	All 0	W	These bits store data for Bulk_in transfer

### 14.3.13 USB Endpoint Data Register 2 (UEDR2)

UEDR2 is a data register for endpoint 2 (for Bulk\_out transfer). UEDR2 stores data received from the host. The number of data items to be read must be the number of bytes specified by UESZ2.

When 1 byte is read from UEDR2, UESZ2 is decremented by 1.

UEDR2 is a byte register to which 4-byte address area is assigned. Accordingly, UEDR2 allows the user to read 2-byte or 4-byte data continuously by word transfer or longword transfer.

Bit	Bit Name	Initial Value	R/W	Description
7 to 0	D7 to D0	—	R	These bits store data for Bulk_out transfer

### 14.3.14 USB Endpoint Receive Data Size Register 0o (UESZ0o)

UESZ0o is a receive data size register for endpoint 0 (for Control\_out transfer). UESZ0o indicates the number of bytes of data to be received from the host.

Note that UESZ0o is decremented by 1 every time when 1 byte is read from UEDR0o.

Bit	Bit Name	Initial Value	R/W	Description
7	—	—	R	Reserved
6 to 0	D6 to D0	—	R	These bits indicate the size of data to be received in Control_out transfer

### 14.3.15 USB Endpoint Receive Data Size Register 2 (UESZ2)

UESZ2 is a receive data size register for endpoint 2 (for Bulk\_out transfer). UESZ2 indicates the number of bytes of data to be received from the host.

Note that UESZ2 is decremented by 1 every time when 1 byte is read from UEDR2.

The FIFO for endpoint 2 (for Bulk\_out transfer) has a dual-FIFO configuration. The data size indicated by this register refers to the currently selected FIFO.

Bit	Bit Name	Initial Value	R/W	Description
7	—	—	R	Reserved
6 to 0	D6 to D0	—	R	These bits indicate the size of data to be received in Bulk_out transfer

### 14.3.16 USB Interrupt Flag Register 0 (UIFR0)

UIFR0 is an interrupt flag register indicating the setup command reception, EP0 and EP3 transmission/reception, and bus reset state. If the corresponding bit is set to 1, the corresponding  $\overline{\text{EXIRQ0}}$  or  $\overline{\text{EXIRQ1}}$  interrupt is requested to the CPU. A bit in this register can be cleared by writing 0 to it. Writing 1 to a bit is invalid and causes no operation. Consequently, to clear a flag, write 0 to the corresponding bit and 1 to all the other bits. (For example, write H'DF to clear bit 5.) The bit-clear instruction is a read/modify/write instruction, so if a new flag is set between the read and write operations, there is a danger that it may be cleared erroneously. Therefore, do not use the bit-clear instruction to clear bits in this interrupt flag register.



Bit	Bit Name	Initial Value	R/W	Description
7	BRST	0	R/(W)*	<p>Bus Reset</p> <p>Set to 1 when the bus reset signal is detected on the USB bus. The corresponding interrupt output is <math>\overline{\text{EXIRQ0}}</math> or <math>\overline{\text{EXIRQ1}}</math>.</p> <p>Note that BRST is also set to 1 if D+ is not pulled-up during USB cable connection.</p>
6	—	0	R	<p>Reserved</p> <p>This bit is always read as 0 and cannot be modified.</p>
5	EP3TR	0	R/(W)*	<p>EP3 Transfer Request</p> <p>Set to 1 if there is no valid data in the FIFO when an IN token is sent from the host to EP3. The corresponding interrupt output is <math>\overline{\text{EXIRQ0}}</math> or <math>\overline{\text{EXIRQ1}}</math>.</p>
4	EP3TS	0	R/(W)*	<p>EP3 Transmit Complete</p> <p>Set to 1 if the data written in EP3 is transmitted to the host normally and the ACK handshake is returned. The corresponding interrupt output is <math>\overline{\text{EXIRQ0}}</math> or <math>\overline{\text{EXIRQ1}}</math>.</p>
3	EP0oTS	0	R/(W)*	<p>EP0o Receive Complete</p> <p>Set to 1 if EP0o receives data from the host normally and returns the ACK handshake to the host. The corresponding interrupt output is <math>\overline{\text{EXIRQ0}}</math> or <math>\overline{\text{EXIRQ1}}</math>.</p>
2	EP0iTR	0	R/(W)*	<p>EP0i Transfer Request</p> <p>Set to 1 if there is no valid data in the FIFO when an IN token is sent from the host to EP0i. The corresponding interrupt output is <math>\overline{\text{EXIRQ0}}</math> or <math>\overline{\text{EXIRQ1}}</math>.</p>
1	EP0iTS	0	R/(W)*	<p>EP0i Transmit Complete</p> <p>Set to 1 if the data written in EP0i is transmitted to the host normally and the ACK handshake is returned. The corresponding interrupt output is <math>\overline{\text{EXIRQ0}}</math> or <math>\overline{\text{EXIRQ1}}</math>.</p>
0	SetupTS	0	R/(W)*	<p>Setup Command Receive Complete</p> <p>Set to 1 if EP0s normally receives 8-byte command data to be decoded by the function from the host and returns the ACK handshake to the host. The corresponding interrupt output is <math>\overline{\text{EXIRQ0}}</math> or <math>\overline{\text{EXIRQ1}}</math>.</p>

Note:\* The write value should always be 0 to clear this flag.

### 14.3.17 USB Interrupt Flag Register 1 (UIFR1)

UIFR1 is an interrupt flag register indicating the EP1 and EP2 status. If the corresponding bit is set to 1, the corresponding  $\overline{\text{EXIRQ0}}$  or  $\overline{\text{EXIRQ1}}$  interrupt is requested to the CPU. EP1TR flags can be cleared by writing 0 to them. Writing 1 to them is invalid and causes no operation.

Consequently, to clear a flag, write 0 to the corresponding bit and 1 to all the other bits. (For example, write H'FD to clear bit 1.) The bit-clear instruction is a read/modify/write instruction, so if a new flag is set between the read and write operations, there is a danger that it may be cleared erroneously. Therefore, do not use the bit-clear instruction to clear bits in this interrupt flag register. However, EP1EMPTY, EP2READY, and EP1ALLEMPTYs are status bits to indicate the EP1, EP2, and FIFO state respectively, and cannot be cleared.

Bit	Bit Name	Initial Value	R/W	Description
7 to 4	—	All 0	R	Reserved These bits are always read as 0 and cannot be modified.
3	EP1ALLEMPTYs	1	R	EP1 FIFO All Empty Status EP1 FIFO has a dual-FIFO configuration. This bit is set to 1 if there is no valid data in both FIFOs. This corresponds to the negative-electrode signal for the EP1DE bit in UDSR. An interrupt cannot be required by EP1ALLEMPTY.
2	EP2READY	0	R	EP2 Data Ready EP2 FIFO has a dual-FIFO configuration. This bit is set to 1 if there is valid data at least in either of FIFOs. This bit is cleared to 0 if there is no valid data in both FIFOs. This bit is a status bit and cannot be cleared. The corresponding interrupt output is $\overline{\text{EXIRQ0}}$ or $\overline{\text{EXIRQ1}}$ .
1	EP1TR	0	R/(W)*	EP1 Transfer Request Set to 1 if there is no valid data in both FIFOs when an IN token is sent from the host to EP1. The corresponding interrupt output is $\overline{\text{EXIRQ0}}$ or $\overline{\text{EXIRQ1}}$ .
0	EP1EMPTY	1	R	EP1 FIFO Empty EP1 FIFO has a dual-FIFO configuration. This bit is set to 1 if there is no valid data at least in either of FIFOs. This bit is cleared to 0 if there is valid data in both FIFOs. This bit is a status bit and cannot be cleared. The corresponding interrupt output is $\overline{\text{EXIRQ0}}$ or $\overline{\text{EXIRQ1}}$ .

Note:\* The write value should always be 0 to clear this flag.

### 14.3.18 USB Interrupt Flag Register 3 (UIFR3)

UIFR3 is an interrupt flag register indicating the USB status. If the corresponding bit is set to 1, the corresponding  $\overline{\text{EXIRQ0}}$ ,  $\overline{\text{EXIRQ1}}$ , or  $\overline{\text{IRQ6}}$  interrupt is requested to the CPU.  $\text{VBUS}_i$ ,  $\text{SPRS}_i$ ,  $\text{SETC}$ ,  $\text{SOF}$ , and  $\text{CK48READY}$  flags can be cleared by writing 0 to them. Writing 1 to them is invalid and causes no operation. Consequently, to clear a flag, write 0 to the corresponding bit and 1 to all the other bits. (For example, write H'DF to clear bit 5.) The bit-clear instruction is a read/modify/write instruction, so if a new flag is set between the read and write operations, there is a danger that it may be cleared erroneously. Therefore, do not use the bit-clear instruction to clear bits in this interrupt flag register.  $\text{VBUS}_i$ s and  $\text{SPRS}_i$ s are status bits and cannot be cleared.

Bit	Bit Name	Initial Value	R/W	Description
7	CK48READY	0	R/(W)*	<p>USB Operating Clock (48 MHz) Stabilization Detection</p> <p>Set to 1 when the USB operating clock (48 MHz) stabilization time has been automatically counted after USB module stop mode cancellation. The corresponding interrupt output is <math>\overline{\text{EXIRQ0}}</math> or <math>\overline{\text{EXIRQ1}}</math>.</p> <p>CK48READY can also operate in the USB interface software reset state (the UIFRST bit in UCTLR is set to 1).</p> <p>Refer to the UCKS3 to UCKS0 bits in section 14.3.1, USB Control Register (UCTLR).</p>
6	SOF	0	R/(W)*	<p>Start of Frame Packet Detection</p> <p>Set to 1 if the Start of Frame (SOF) packet is detected. The corresponding interrupt output is <math>\overline{\text{EXIRQ0}}</math> or <math>\overline{\text{EXIRQ1}}</math>.</p>
5	SETC	0	R/(W)*	<p>Set_Configuration Command Detection</p> <p>Set to 1 if the Set_Configuration command is detected. The corresponding interrupt output is <math>\overline{\text{EXIRQ0}}</math> or <math>\overline{\text{EXIRQ1}}</math>.</p>
4	—	0	R	<p>Reserved</p> <p>This bit is always read as 0 and cannot be modified.</p>
3	SPRSs	0	R	<p>Suspend/Resume Status</p> <p>SPRSs indicates the suspend/resume status. However, an interrupt cannot be requested by SPRSs.</p> <p>0: Indicates that the bus is in the normal state.</p> <p>1: Indicates that the bus is in the suspend state.</p>

Bit	Bit Name	Initial Value	R/W	Description
2	SPRSi	0	R/(W)*	Suspend/Resume Interrupt Set to 1 if a transition from normal state to suspend state or suspend state to normal state has occurred. The corresponding interrupt output is $\overline{\text{IRQ6}}$ . This bit can be used to cancel power-down mode at resuming.
1	VBUSs	0	R	VBUS Status VBUSs is a status bit to indicate the VBUS state by the USB cable connection or disconnection. However, an interrupt cannot be requested by VBUSs. 0: Indicates that the VBUS (USB cable) bus is disconnected. 1: Indicates that the VBUS (USB cable) bus is connected.
0	VBUSi	0	R/(W)*	VBUS Interrupt Set to 1 if a VBUS state changes by the USB cable connection or disconnection. The corresponding interrupt output is $\overline{\text{EXIRQ0}}$ or $\overline{\text{EXIRQ1}}$ .

Note:\* The write value should always be 0 to clear this flag.

### 14.3.19 USB Interrupt Enable Register 0 (UIER0)

UIER0 enables the interrupt request indicated in the interrupt flag register 0 (UIFR0). When an interrupt flag is set while the corresponding bit in UIER0 is set to 1, an interrupt is requested by asserting the corresponding  $\overline{\text{EXIRQ0}}$  or  $\overline{\text{EXIRQ1}}$ . Either  $\overline{\text{EXIRQ0}}$  or  $\overline{\text{EXIRQ1}}$  must be selected by the interrupt select register 0 (UISR0).

Bit	Bit Name	Initial Value	R/W	Description
7	BRSTE	0	R/W	Enables the BRST interrupt.
6	—	0	R	Reserved This bit is always read as 0.
5	EP3TRE	0	R/W	Enables the EP3TR interrupt.
4	EP3TSE	0	R/W	Enables the EP3TS interrupt.
3	EP0oTSE	0	R/W	Enables the EP0oTS interrupt.
2	EP0iTRE	0	R/W	Enables the EP0iTR interrupt.
1	EP0iTSE	0	R/W	Enables the EP0iTS interrupt.
0	SetupTSE	0	R/W	Enables the SetupTS interrupt.

### 14.3.20 USB Interrupt Enable Register 1 (UIER1)

UIER1 enables the interrupt request indicated in the interrupt flag register 1 (UIFR1). When an interrupt flag is set while the corresponding bit in UIER1 is set to 1, an interrupt is requested by asserting the corresponding  $\overline{\text{EXIRQ0}}$  or  $\overline{\text{EXIRQ1}}$ . Either  $\overline{\text{EXIRQ0}}$  or  $\overline{\text{EXIRQ1}}$  must be selected by the interrupt select register 1 (UISR1).

Bit	Bit Name	Initial Value	R/W	Description
7 to 4	—	All 0	R	Reserved These bits are always read as 0.
3	—	0	R/W	Reserved The write value should always be 0.
2	EP2READYE	0	R/W	Enables the EP2READY interrupt.
1	EP1TRE	0	R/W	Enables the EP1TR interrupt.
0	EP1EMPTYE	0	R/W	Enables the EP1EMPTYE interrupt.

### 14.3.21 USB Interrupt Enable Register 3 (UIER3)

UIER3 enables the interrupt request indicated in the interrupt flag register 3 (UIFR3). This register is readable/writable while the USB module stop 2 bit (MSTPB0) in MSTPCRB is 1.

When an interrupt flag is set while the corresponding bit in UIER3 is set to 1, an interrupt is requested by asserting the corresponding  $\overline{\text{EXIRQ0}}$  or  $\overline{\text{EXIRQ1}}$ . Either  $\overline{\text{EXIRQ0}}$  or  $\overline{\text{EXIRQ1}}$  must be selected by the interrupt select register 3 (UISR3). Note, however, that the SPRSiE bit is an interrupt enable bit specific to the  $\overline{\text{IRQ6}}$  pin and cannot be selected by UISR3.

Bit	Bit Name	Initial Value	R/W	Description
7	CK48READYE	1	R/W	Enables the CK48READY interrupt.
6	SOFE	0	R/W	Enables the SOF interrupt.
5	SETCE	0	R/W	Enables the SETC interrupt.
4, 3	—	All 0	R	Reserved These bits are always read as 0.
2	SPRSiE	0	R/W	Enables the SPRSi interrupt. (only for $\overline{\text{IRQ6}}$ )
1	—	0	R	Reserved This bit is always read as 0.
0	VBUSiE	0	R/W	Enables the VBUSi interrupt.

### 14.3.22 USB Interrupt Select Register 0 (UISR0)

UISR0 sets  $\overline{\text{EXIRQ}}$  to output interrupt request indicated in the interrupt flag register 0 (UIFR0). When a bit in UIER0 corresponding to the UISR0 bit is cleared to 0, an interrupt request is output from  $\overline{\text{EXIRQ0}}$ . When a bit in UIER0 corresponding to the UISR0 bit is set to 1, an interrupt request is output from  $\overline{\text{EXIRQ1}}$ .

Bit	Bit Name	Initial Value	R/W	Description
7	BRSTS	0	R/W	Selects the BRST interrupt.
6	—	0	R	Reserved This bit is always read as 0.
5	EP3TRS	0	R/W	Selects the EP3TR interrupt.
4	EP3TSS	0	R/W	Selects the EP3TS interrupt
3	EP0oTSS	0	R/W	Selects the EP0oTS interrupt.
2	EP0iTRS	0	R/W	Selects the EP0iTR interrupt.
1	EP0iTSS	0	R/W	Selects the EP0iTS interrupt.
0	SetupTSS	0	R/W	Selects the SetupTS interrupt.

### 14.3.23 USB Interrupt Select Register 1 (UISR1)

UISR1 sets  $\overline{\text{EXIRQ}}$  to output interrupt request indicated in the interrupt flag register 1 (UIFR1). When a bit in UIER1 corresponding to the UISR1 bit is cleared to 0, an interrupt request is output from  $\overline{\text{EXIRQ0}}$ . When a bit in UIER1 corresponding to the UISR1 bit is set to 1, an interrupt request is output from  $\overline{\text{EXIRQ1}}$ .

Bit	Bit Name	Initial Value	R/W	Description
7 to 4	—	All 0	R	Reserved These bits are always read as 0.
3	—	0	R/W	Reserved The write value should always be 0.
2	EP2READYS	0	R/W	Selects the EP2READY interrupt.
1	EP1TRS	0	R/W	Selects the EP1TR interrupt.
0	EP1EMPTYS	0	R/W	Selects the EP1EMPTY interrupt.

### 14.3.24 USB Interrupt Select Register 3 (UISR3)

UISR3 sets  $\overline{\text{EXIRQ}}$  to output interrupt request indicated in the interrupt flag register 3 (UIFR3). When a bit in UIER3 corresponding to the UISR3 bit is cleared to 0, an interrupt request is output from  $\overline{\text{EXIRQ0}}$ . When a bit in UIER3 corresponding to the UISR3 bit is set to 1, an interrupt request is output from  $\overline{\text{EXIRQ1}}$ .

Bit	Bit Name	Initial Value	R/W	Description
7	CK48READYS	0	R/W	Selects the CK48READY interrupt.
6	SOFS	0	R/W	Selects the SOF interrupt.
5	SETCS	0	R/W	Selects the SETC interrupt.
4 to 1	—	All 0	R	Reserved These bits are always read as 0.
0	VBUSiS	0	R/W	Selects the VBUSi interrupt.

### 14.3.25 USB Data Status Register (USDR)

USDR indicates whether the IN FIFO data registers (EP1, and EP3) contain valid data or not. A bit in USDR is set when data written to the corresponding IN FIFO becomes valid after the corresponding PKTE bit in UTRG is set to 1. A bit in USDR is cleared when all valid data is sent to the host. For EP1, having a dual-FIFO configuration, the corresponding bit in USDR is cleared to 0 and FIFO becomes empty.

Bit	Bit Name	Initial Value	R/W	Description
7 to 3	—	All 0	R	Reserved These bits are always read as 0 and cannot be modified.
2	EP1DE	0	R	EP1 Data Enable 0: Indicates that the EP1 contains no valid data. 1: Indicates that the EP1 contains valid data. EP1DE corresponds to the negative-electrode signal for EP1ALLEMPYs in UIFR1.
1	EP3DE	0	R	EP3 Data Enable 0: Indicates that the EP3 contains no valid data. 1: Indicates that the EP3 contains valid data.
0	EP0iDE	0	R	EP0i Data Enable 0: Indicates that the EP0i contains no valid data. 1: Indicates that the EP0i contains valid data.

#### 14.3.26 USB Configuration Value Register (UCVR)

UCVR stores the Configuration value when the Set\_Configuration command is received from the host.

Bit	Bit Name	Initial Value	R/W	Description
7, 6	—	All 0	R	Reserved These bits are always read as 0 and cannot be modified.
5	CNFV0	0	R	Configuration Value 0 Stores the Configuration value when the Set_Configuration command is received. CNFV0 is modified when the SETC bit in UIFR3 is set to 1.
4 to 0	—	All 0	R	Reserved These bits are always read as 0 and cannot be modified.



### 14.3.27 USB Test Register 0 (UTSTR0)

UTSTR0 controls the on-chip transceiver output signals. Setting the PTSTE bit to 1 after setting UIFRST and UDCRST in UCTLR to 0 specifies the transceiver output signals (USD+ and USD-) arbitrarily. Table 14.2 shows the relationship between UTSTR0 setting and pin output.

Bit	Bit Name	Initial Value	R/W	Description
7	PTSTE	0	R/W	Pin Test Enable Enables the test control for the on-chip transceiver output pins (USD+ and USD-) and USPND pin.
6 to 4	—	All 0	R	Reserved These bits are always read as 0 and cannot be modified.
3	SUSPEND	0	R/W	On-Chip Transceiver Output Signal Setting
2	$\overline{OE}$	1	R/W	SUSPEND: Sets the USPND pin signal of the on-chip transceiver.
1	FSE0	0	R/W	$\overline{OE}$ : Sets the output enable ( $\overline{OE}$ ) signal of the on-chip transceiver.
0	VPO	0	R/W	FSE0: Sets the single-ended 0 (FSE0) signal of the on-chip transceiver. VPO: Sets the USD+ (VPO) signal of the on-chip transceiver.

**Table 14.2 Relationship between UTSTR0 Setting and Pin Output**

Register Setting			Pin Output	Pin Input	Register Setting					Pin Output	
UCTLR/ TMOWE	PTSTE	SUSPEND	USPND/ TMOW	VBUS	PTSTE	$\overline{OE}$	FSE0	VPO	USD+	USD-	
1	x	x	—	0	x	x	x	x	Hi-Z	Hi-Z	
0	0	x	—	1	0	x	x	x	—	—	
0	1	0	0	1	1	0	0	0	0	1	
0	1	1	1	1	1	0	0	1	1	0	
				1	1	0	1	x	0	0	
				1	1	1	x	x	Hi-Z	Hi-Z	

Legend:

x: Don't care

—: Cannot be controlled. Indicates state in normal operation according to the USB operation and port settings.

### 14.3.28 USB Test Register 1 (UTSTR1)

UTSTR1 allows the USB control pin and on-chip transceiver input signals to be monitored. Table 14.3 shows the relationship between pin input and UTSTR1 monitoring value.

Bit	Bit Name	Initial Value	R/W	Description
7	VBUS	—*	R	On-Chip Transceiver Input Signal Monitor
6	$\overline{UBPM}$	—*	R	VBUS: Monitors the VBUS pin. $\overline{UBPM}$ : Monitors the $\overline{UBPM}$ pin.
5 to 3	—	All 0	R	Reserved These bits are always read as 0 and cannot be modified.
2	RCV	—*	R	On-Chip Transceiver Input Signal Monitor
1	VP	—*	R	RCV: Monitors the differential input level (RCV) signal of the on-chip transceiver.
0	VM	—*	R	VP: Monitors the USD+ (VP) signal of the on-chip transceiver. VM: Monitors the USD- (VM) signal of the on-chip transceiver.

Note: \* Determined by the state of pins. VBUS,  $\overline{UBPM}$ , USD+, USD-

Table 14.3 Relationship between Pin Input and UTSTR1 Monitoring Value

Pin Input		UTSTR1 Monitoring Value		Register Setting			Pin Input			UTSTR1 Monitoring Value		
VBUS	$\overline{\text{UBPM}}$	VBUS	$\overline{\text{UBPM}}$	UTSTR0/ PTSTE	UTSTR0/ SUSPEND	VBUS	USD+	USD-	RCV	VP	VM	
0/1	x	0/1	x	x	x	0	x	x	0	0	0	
x	0/1	x	0/1	0	x	1	0	0	x	0	0	
				0	x	1	0	1	0	0	1	
				0	x	1	1	0	1	1	0	
				0	x	1	1	1	x	1	1	
				1	0	1	0	0	x	0	0	
				1	0	1	0	1	0	0	1	
				1	0	1	1	0	1	1	0	
				1	0	1	1	1	x	1	1	
				1	1	1	0	0	0	0	0	
				1	1	1	0	1	0	0	1	
				1	1	1	1	0	0	1	0	
				1	1	1	1	1	0	1	1	

Legend:

x: Don't care

0/1: Combination for pin input = UTSTR1 monitoring value.

**14.3.29 USB Test Registers 2 and A to F (UTSTR2, UTSTRA to UTSTRF)**

UTSTR2 and UTSRТА to UTSRTF are test registers and cannot be written to.

**14.3.30 Module Stop Control Register B (MSTPCRB)**

Bit	Bit Name	Initial Value	R/W	Description
7	MSTPB7	1	R/W	Module Stop
6	MSTPB6	1		For details, refer to section 20.1.3, Module Stop Control Registers A to C (MSTPCRA to MSTPCRC).
5	MSTPB5	1		
4	MSTPB4	1		
3	MSTPB3	1		
2	MSTPB2	1		
1	MSTPB1	1		
0	MSTPB0	1	R/W	USB Module Stop 2 0: Cancels the stop state of the USB module completely. A clock is provided for the USB module completely. Before clearing this bit, make sure to clear the USBSTOP1 bit in EXMDLSTP. After this bit has been cleared, the internal PLL circuit starts operation. Registers in the USB module must be accessed after the USB operating clock stabilization time (the CK48READY bit in UIFR3 is set to 1) has passed. 1: Places the USB module partly in the stop state. The internal PLL circuit and the most of the clocks in the USB module stop operation. However, register values in the USB module are maintained.

### 14.3.31 Extended Module Stop Register (EXMDLSTP)

Bit	Bit Name	Initial Value	R/W	Description
7 to 2	—	Undefined	—	Reserved These bits are always read as an undefined value and cannot be modified.
1	RTCSTOP	0	R/W	RTC Module Stop 0: Cancels the RTC module stop. 1: Sets the RTC module stop.
0	USBSTOP1	0	R/W	USB Module Stop 1 0: Cancels the stop state of the USB module partly. A clock is provided for the USB module partly. After this bit has been cleared, only the UCTLR and UIER3 registers in the USB module can be accessed. To access the other registers, clear the MSTPB0 bit in MSTPCRB to 0. 1: Places the USB module completely in the stop state. The clocks in the USB module stop operation completely. However, register values in the USB module are maintained.

- Notes:
1. For details on USB module stop mode cancellation procedure, refer to section 14.5, Communication Operation.
  2. When reading pin states using the port D register (PORTD), after accessing EXMDLSTP (address range: H'FFFF40 to H'FFFF5F), you must perform a dummy read to the external address space (such as H'FFEF00 to H'FF7FF) outside the range H'FFFF40 to H'FFFF5F before reading PORTD.

## 14.4 Interrupt Sources

This module has three interrupt signals. Table 14.4 shows the interrupt sources and their corresponding interrupt request signals. The  $\overline{\text{EXIRQ}}$  interrupt signals are activated at low level. The  $\overline{\text{EXIRQ}}$  interrupt requests can only be detected at low level (specified as level sensitive). The suspend/resume interrupt request  $\overline{\text{IRQ6}}$  must be specified to be detected at the falling edge (falling-edge sensitive) by the interrupt controller register.

Table 14.4 Interrupt Sources

Register	Bit	Transfer Mode	Interrupt Source	Description	Interrupt Request Signal	DMAC Activation by USB Request* <sup>5</sup>
UIFR0	0	Control transfer (EP0)	SetupTS* <sup>1</sup>	Setup command receive complete	$\overline{\text{EXIRQ0}}$ or $\overline{\text{EXIRQ1}}$	×
	1		EP0iTS* <sup>1</sup>	EP0i transfer complete	$\overline{\text{EXIRQ0}}$ or $\overline{\text{EXIRQ1}}$	×
	2	Interrupt_in transfer (EP3)	EP0iTR* <sup>1</sup>	EP0i transfer request	$\overline{\text{EXIRQ0}}$ or $\overline{\text{EXIRQ1}}$	×
	3		EP0oTS* <sup>1</sup>	EP0o receive complete	$\overline{\text{EXIRQ0}}$ or $\overline{\text{EXIRQ1}}$	×
	4		EP3TS	EP3 transfer complete	$\overline{\text{EXIRQ0}}$ or $\overline{\text{EXIRQ1}}$	×
	5	EP3TR	EP3 transfer request	$\overline{\text{EXIRQ0}}$ or $\overline{\text{EXIRQ1}}$	×	
	6	—	Reserved	—	—	—
7	(Status)	BRST	Bus reset	$\overline{\text{EXIRQ0}}$ or $\overline{\text{EXIRQ1}}$	×	
UIFR1	0	Bulk_in transfer (EP1)	EP1EMPTY	EP1 FIFO empty	$\overline{\text{EXIRQ0}}$ or $\overline{\text{EXIRQ1}}$	$\overline{\text{DREQ0}}$ or $\overline{\text{DREQ1}}$ * <sup>2</sup>
	1		EP1TR	EP1 transfer request	$\overline{\text{EXIRQ0}}$ or $\overline{\text{EXIRQ1}}$	×
	2	Bulk_out transfer (EP2)	EP2READY	EP2 data ready	$\overline{\text{EXIRQ0}}$ or $\overline{\text{EXIRQ1}}$	$\overline{\text{DREQ0}}$ or $\overline{\text{DREQ1}}$ * <sup>3</sup>
	3	Bulk_in transfer (EP1)	(EP1ALLEMPYs)	EP1 FIFO all empty status	×	×
	4	—	Reserved	—	—	—
	5	—	—	—	—	—
	6	—	—	—	—	—
7	—	—	—	—	—	

Register	Bit	Transfer Mode	Interrupt Source	Description	Interrupt Request Signal	DMAC Activation by USB Request* <sup>5</sup>
UIFR3	0	— (Status)	VBUSi	VBUS interrupt	$\overline{\text{EXIRQ0}}$ or $\overline{\text{EXIRQ1}}$	×
	1		(VBUSs)	VBUS status	×	×
	2		SPRSi	Suspend/resume interrupt	$\overline{\text{IRQ6}}$ * <sup>4</sup>	×
	3		(SPRSs)	Suspend/resume status	×	×
	4		Reserved	—	—	—
	5		SETC	Set_Configuration detection	$\overline{\text{EXIRQ0}}$ or $\overline{\text{EXIRQ1}}$	×
	6		SOF	Start of Frame packet detection	$\overline{\text{EXIRQ0}}$ or $\overline{\text{EXIRQ1}}$	×
	7		CK48READY	USB operating clock stabilization detection	$\overline{\text{EXIRQ0}}$ or $\overline{\text{EXIRQ1}}$	×

- Notes:
1. EP0 interrupts must be assigned to the same interrupt request signal.
  2. An EP1 DMA transfer by a USB request is specified by the EP1T1 and EP1T0 bits in UDMAR.
  3. An EP2 DMA transfer by a USB request is specified by the EP2T1 and EP2T0 bits in UDMAR.
  4. The suspend/resume interrupt request  $\overline{\text{IRQ6}}$  must be specified to be detected at the falling edge (IRQ6SCB and IRQ6SCA in ISCRH = 01) by the interrupt controller register.
  5. The  $\overline{\text{DREQ}}$  signal is not used for auto-request. The CPU can activate the DMAC using any flags and interrupts.

- $\overline{\text{EXIRQ0}}$  signal

The  $\overline{\text{EXIRQ0}}$  signal requests interrupt sources for which the corresponding bits in interrupt select registers 0 to 3 (UISR0 to UISR3) are cleared to 0. The  $\overline{\text{EXIRQ0}}$  is driven low if a corresponding bit in the interrupt flag register is set to 1.

- $\overline{\text{EXIRQ1}}$  signal

The  $\overline{\text{EXIRQ1}}$  signal requests interrupt sources for which the corresponding bits in interrupt select registers 0 to 3 (UISR0 to UISR3) are cleared to 0. The  $\overline{\text{EXIRQ1}}$  is driven low if a corresponding bit in the interrupt flag register is set to 1.

- $\overline{\text{IRQ6}}$  signal

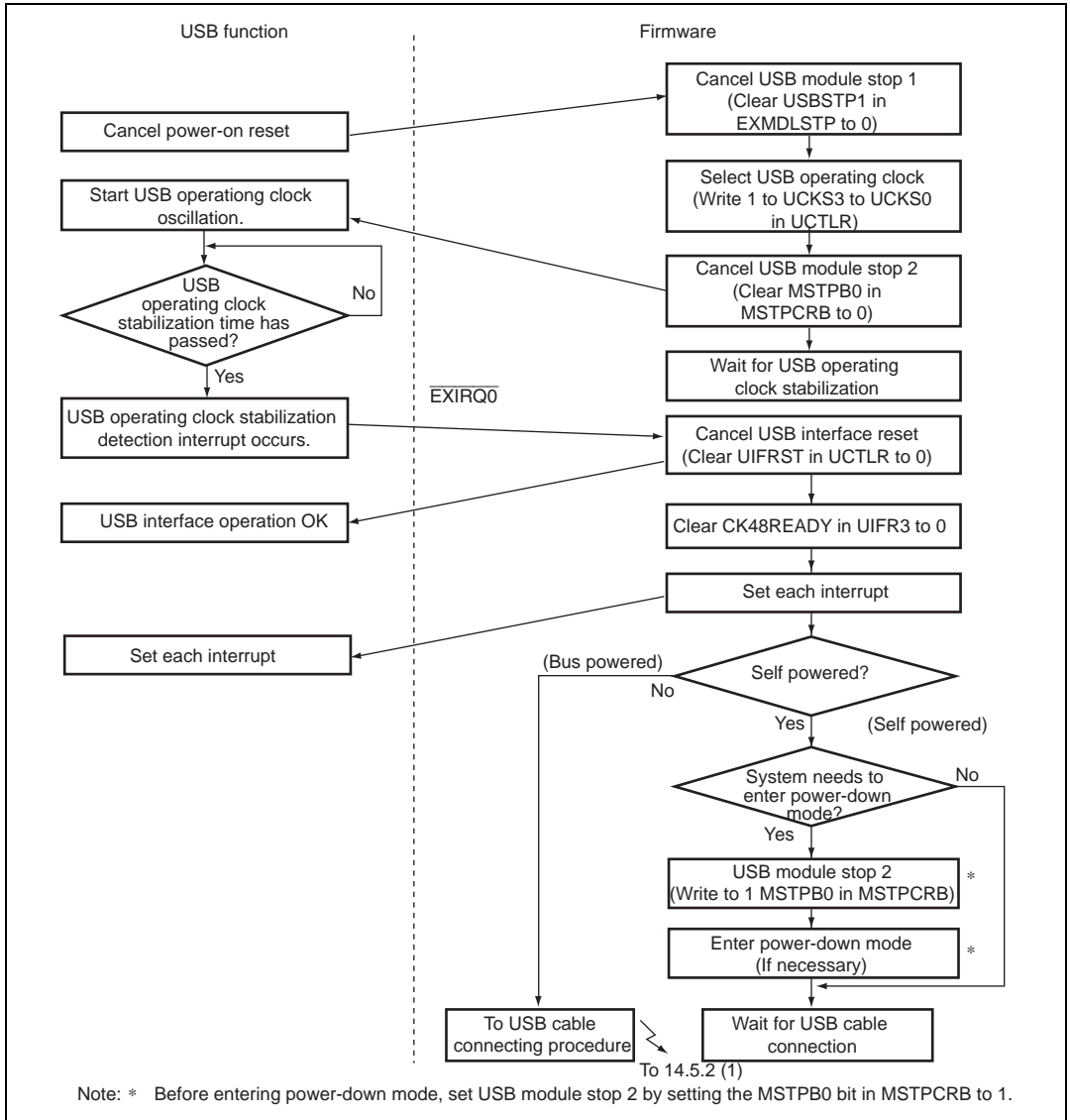
The  $\overline{\text{IRQ6}}$  signal is specific to the suspend/resume interrupt request. The falling edge of the  $\overline{\text{IRQ6}}$  signal is output at the transition from the suspend state or from the resume state.



## 14.5 Communication Operation

### 14.5.1 Initialization

The USB must be initialized as described in the flowchart in figure 14.2.

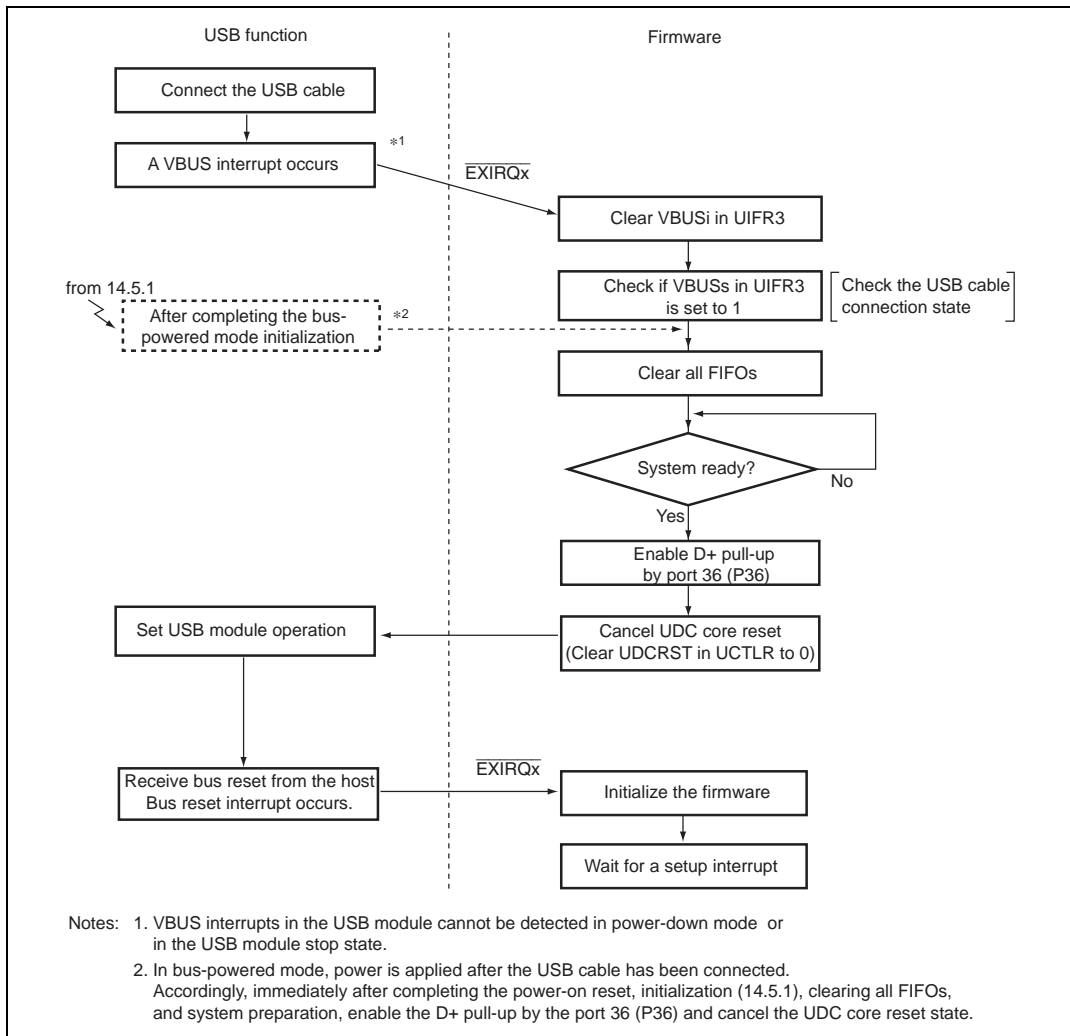


**Figure 14.2 USB Initialization**

## 14.5.2 USB Cable Connection/Disconnection

### (1) USB Cable Connection (When USB module stop or power-down mode is not used)

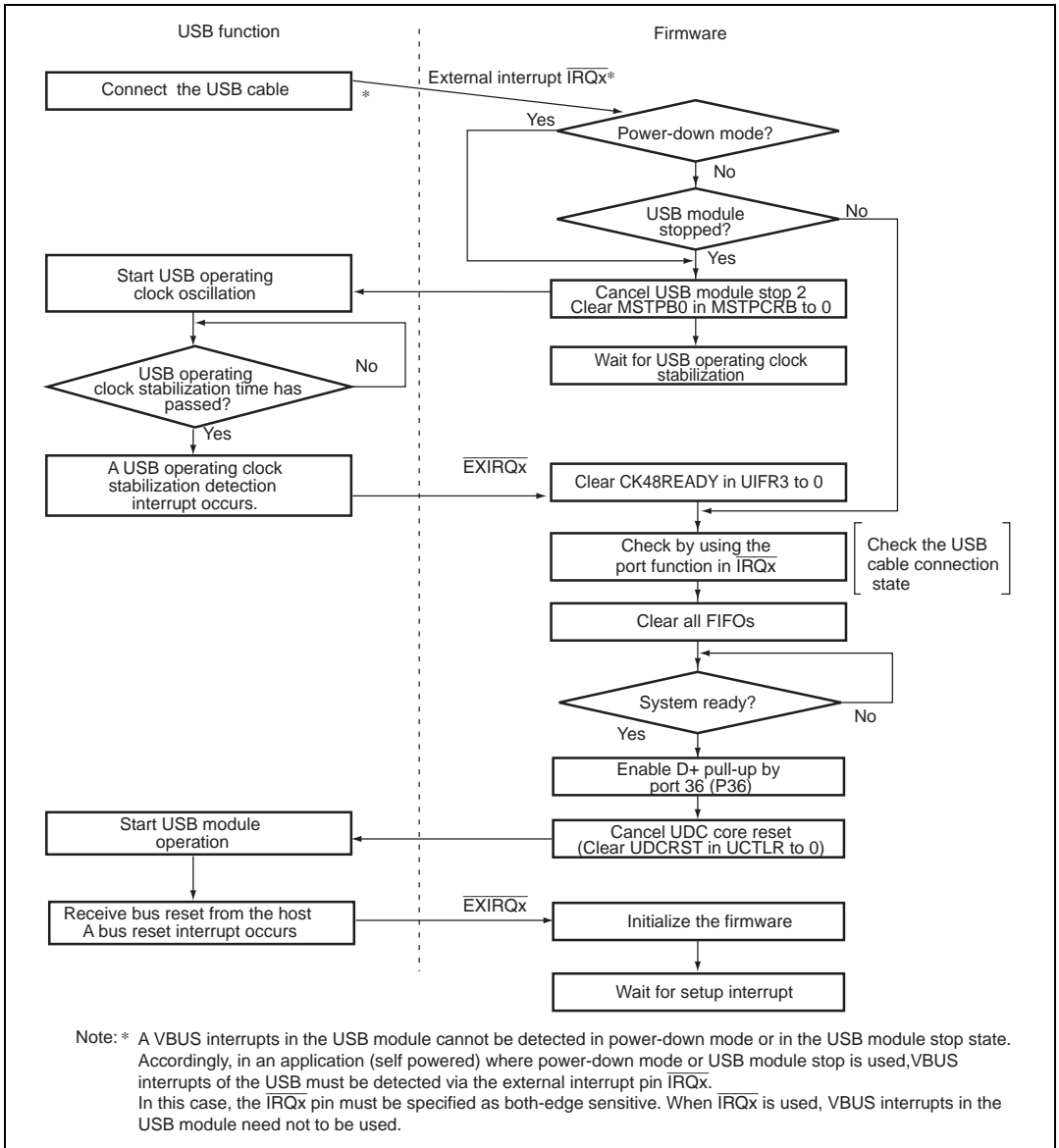
If the USB cable enters the connection state from the disconnection state in an application (self powered) where USB module stop or power-down mode is not used, perform the operation as shown in figure 14.3. In bus-powered mode, perform the operation according to note 2 in figure 14.3.



**Figure 14.3 USB Cable Connection  
(When USB Module Stop or Power-Down Mode Is not Used)**

**(2) USB Cable Connection (When USB module stop or power-down mode is used)**

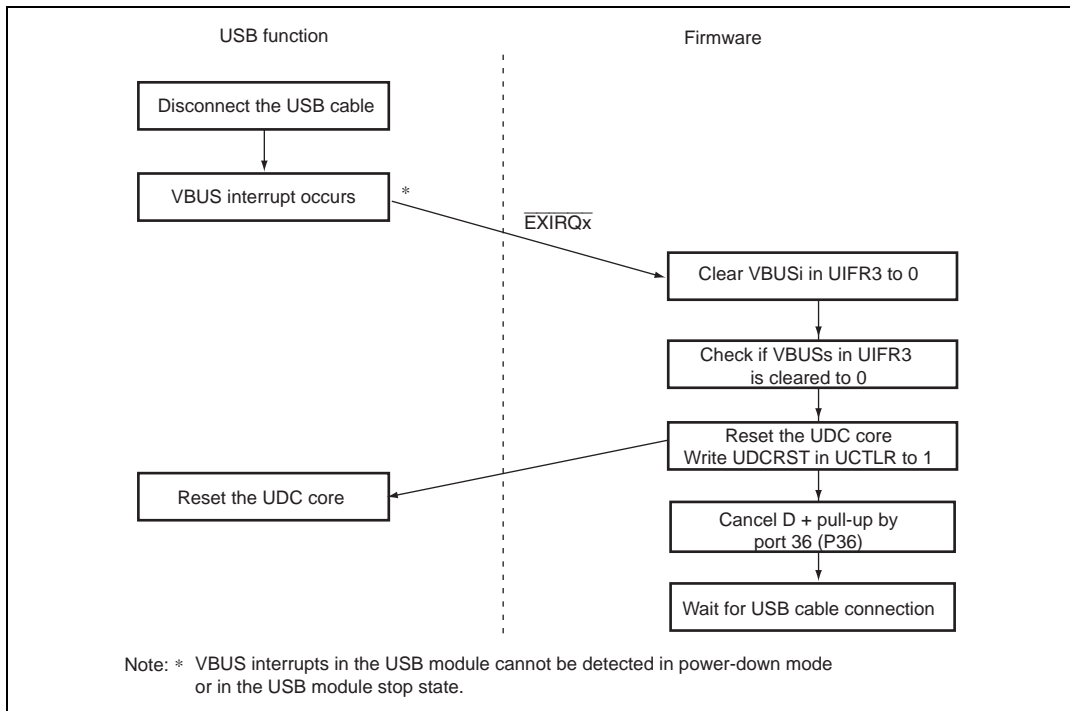
If the USB cable enters the connection state from the disconnection state in an application (self powered) where USB module stop or power-down mode is used, perform the operation as shown in figure 14.4.



**Figure 14.4 USB Cable Connection  
(When USB Module Stop or Power-Down Mode Is Used)**

**(3) USB Cable Disconnection (When USB module stop or power-down mode is not used)**

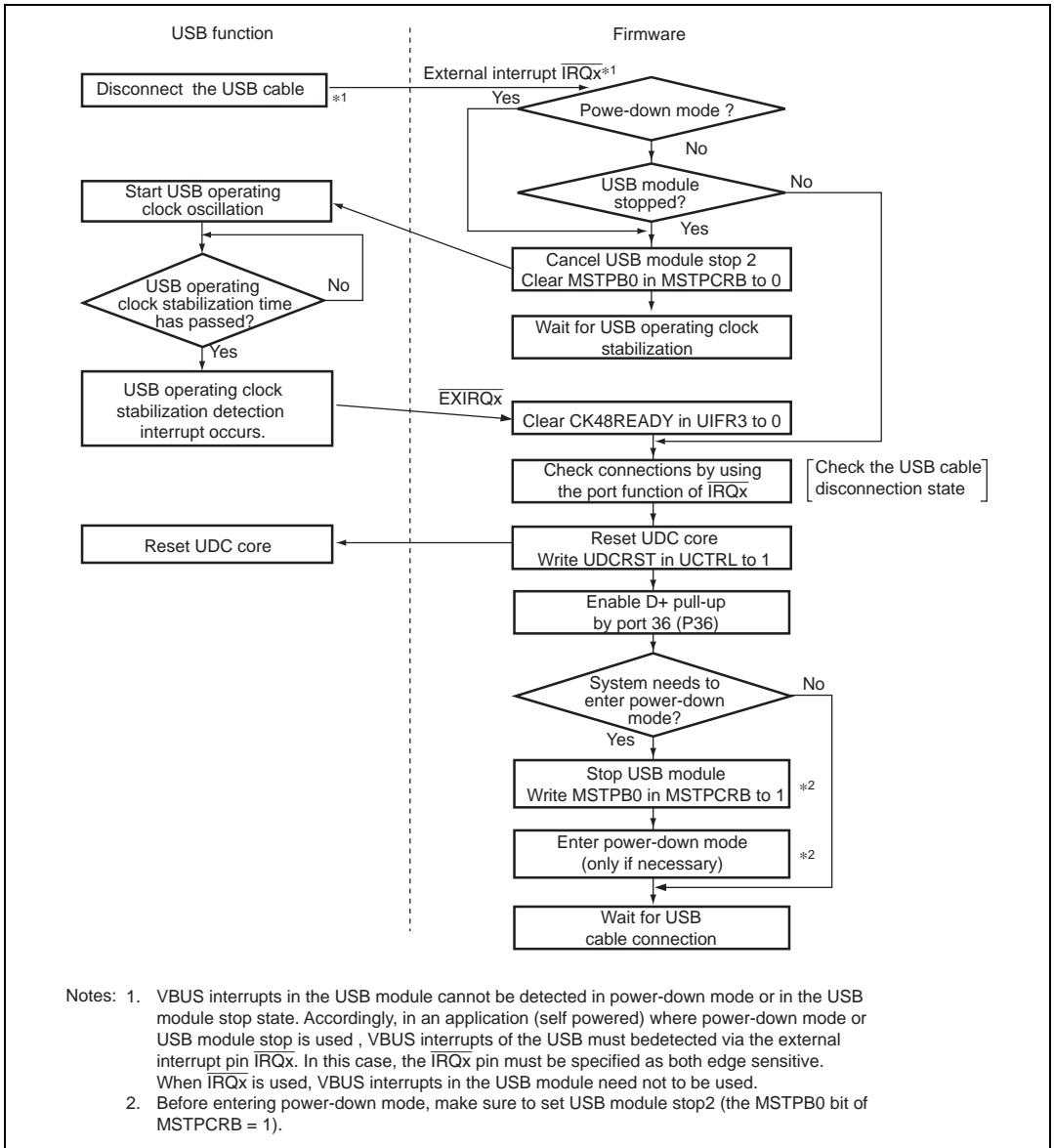
If the USB cable enters the disconnection state from the connection state in an application (self powered) where USB module stop or power-down mode is not used, perform the operation as shown in figure 14.5. In bus-powered mode, the power is automatically turned off when the USB cable is disconnected and the following processing is not required.



**Figure 14.5 USB Cable Disconnection  
(When USB Module Stop or Power-Down Mode Is not Used)**

**(4) USB Cable Disconnection (When USB module stop or power-down mode is used)**

If the USB cable enters the disconnection state from the connection state in an application (self powered) where USB module stop or power-down mode is used, perform the operation as shown in figure 14.6.

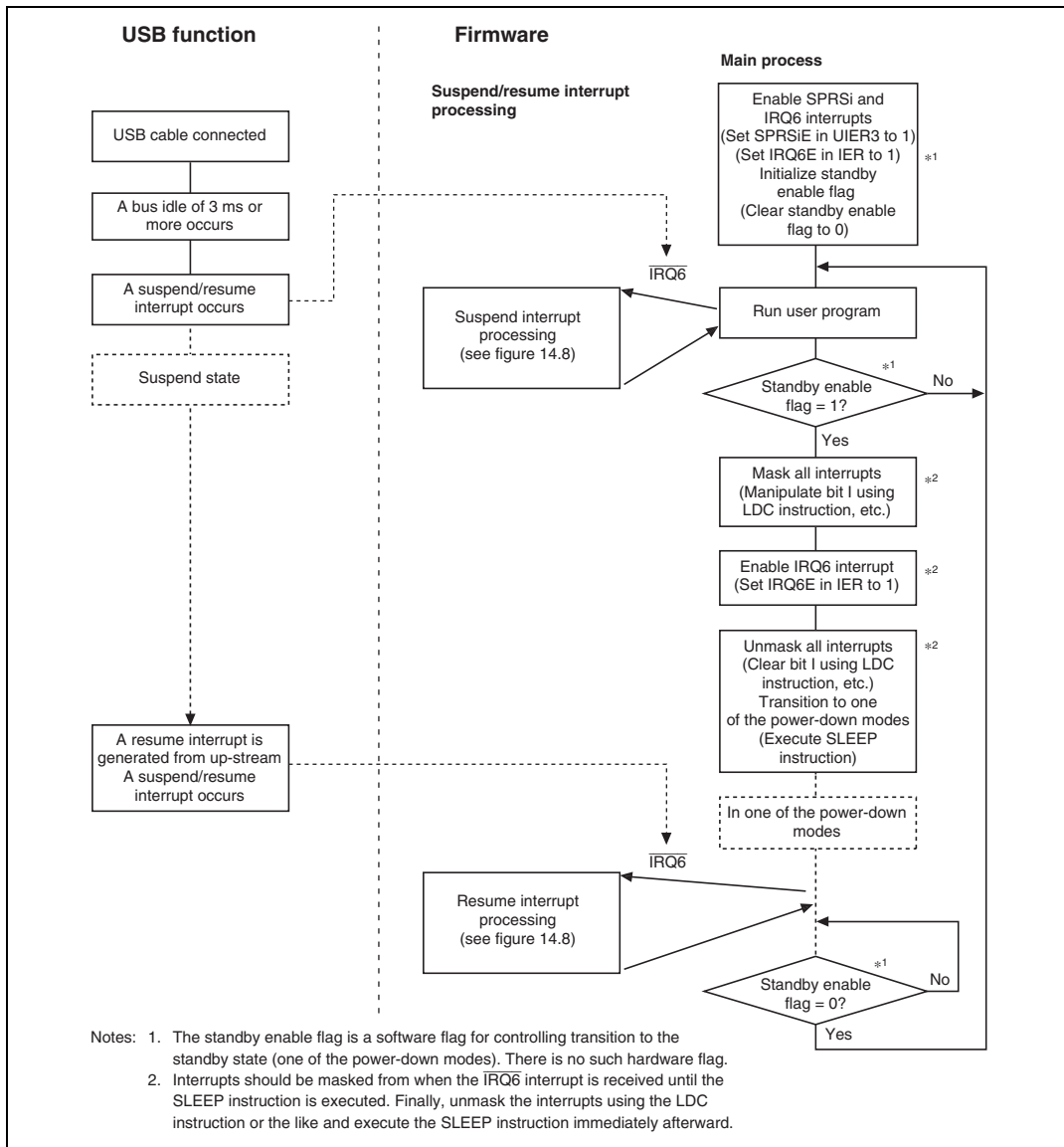


**Figure 14.6 USB Cable Disconnection  
(When USB Module Stop or Power-Down Mode Is Used)**

### 14.5.3 Suspend and Resume Operations

#### (1) Suspend and Resume Operations

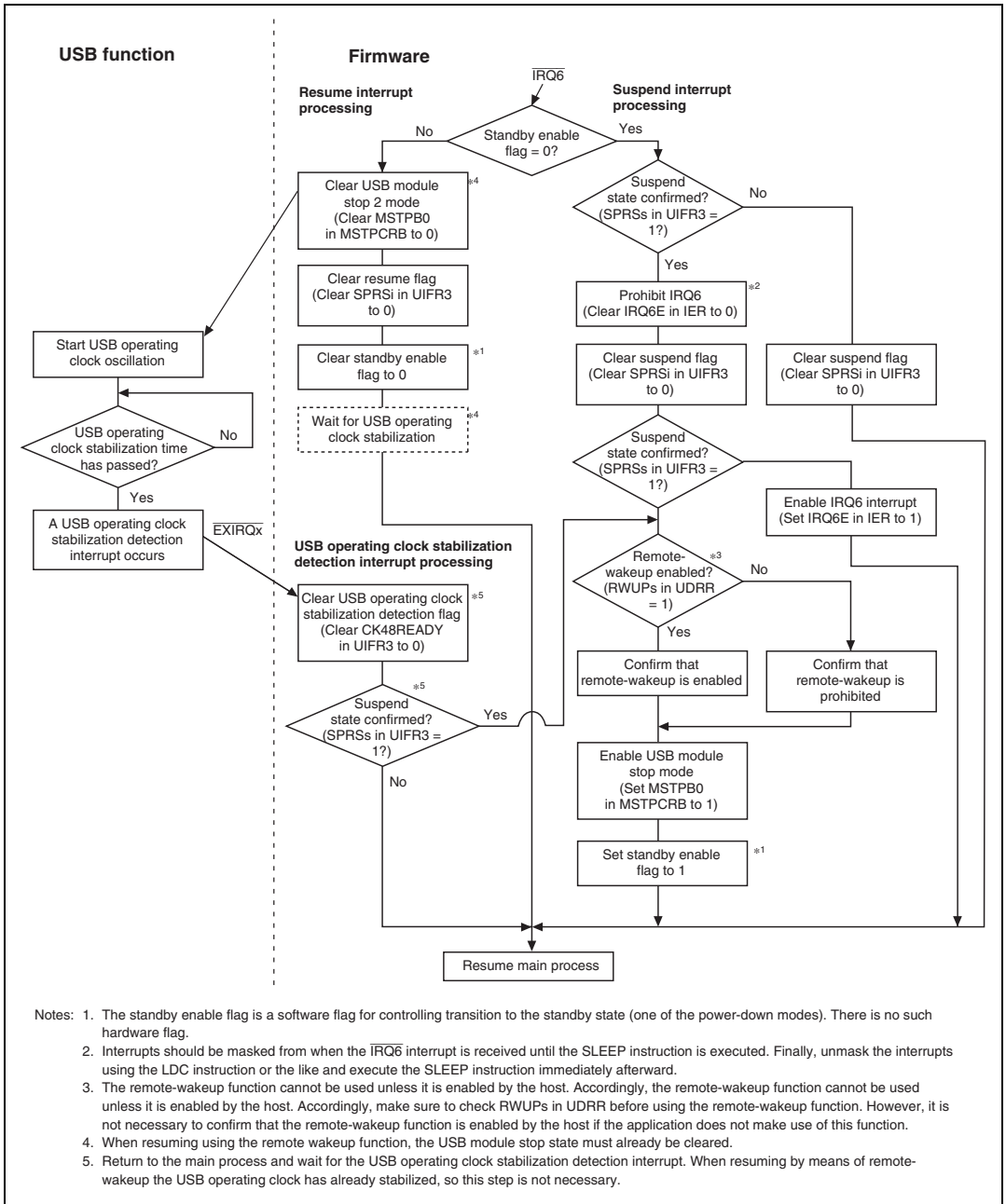
Figures 14.7 and 14.8 are flowcharts of the suspend and resume operations. If the USB bus enters the suspend state from a non-suspend state, or if it enters a non-suspend state from the suspend state due to a resume signal from up-stream, perform the operations shown below.



**Figure 14.7 Example Flowchart of Suspend and Resume Operations**

## (2) Suspend and Resume Interrupt Processing

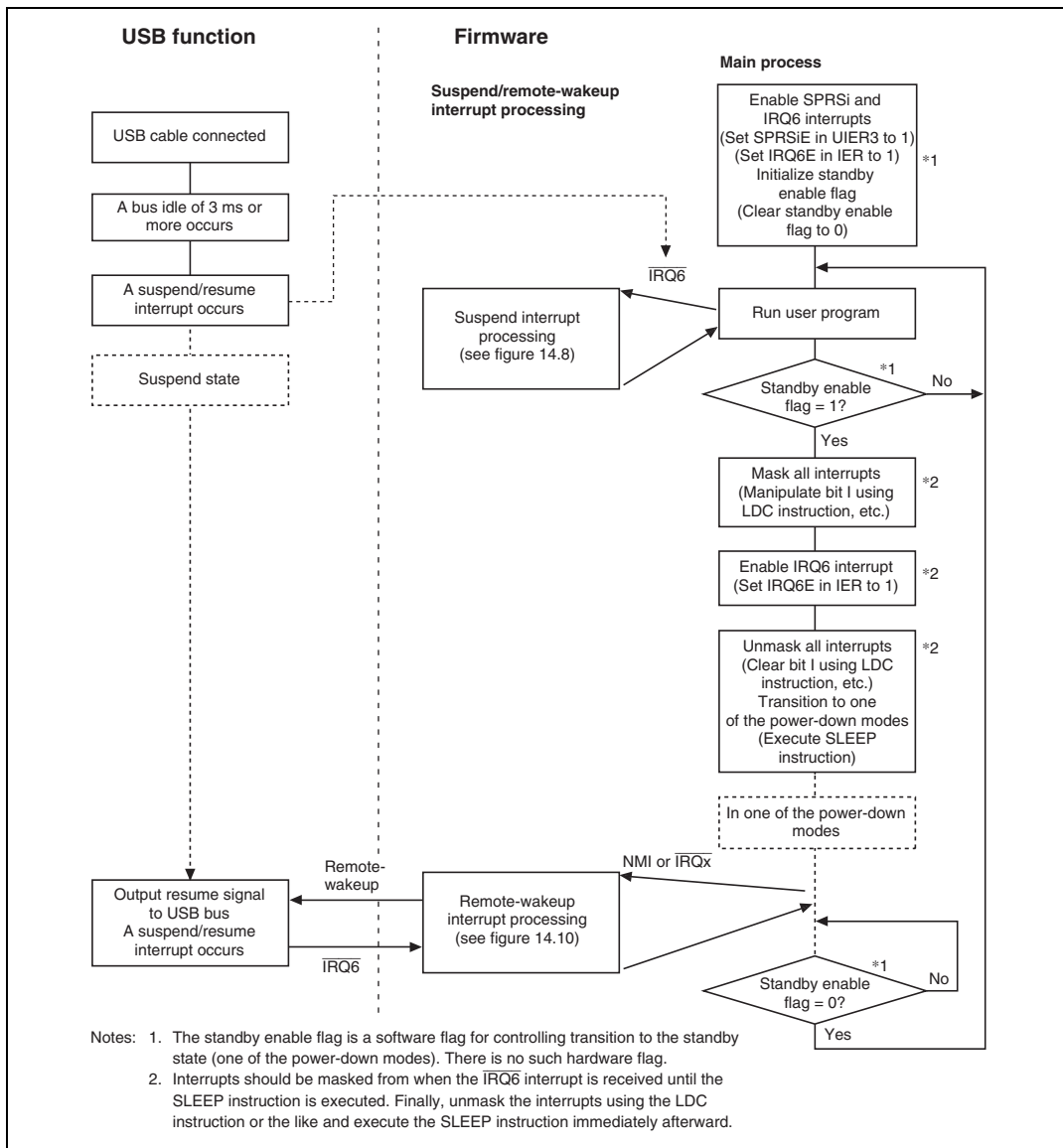
Figure 14.8 is a flowchart of suspend and resume interrupt processing.



**Figure 14.8 Example Flowchart of Suspend and Resume Interrupt Processing**

### (3) Suspend and Remote-Wakeup Operations

Figures 14.9 and 14.10 are flowcharts of the suspend and remote-wakeup operations. If the USB bus enters a non-suspend state from the suspend state due to a remote-wakeup signal from this function, perform the operations shown below.



**Figure 14.9 Example Flowchart of Suspend and Remote-Wakeup Operations**



## (4) Remote-Wakeup Interrupt Processing

Figure 14.10 is a flowchart of remote-wakeup interrupt processing.

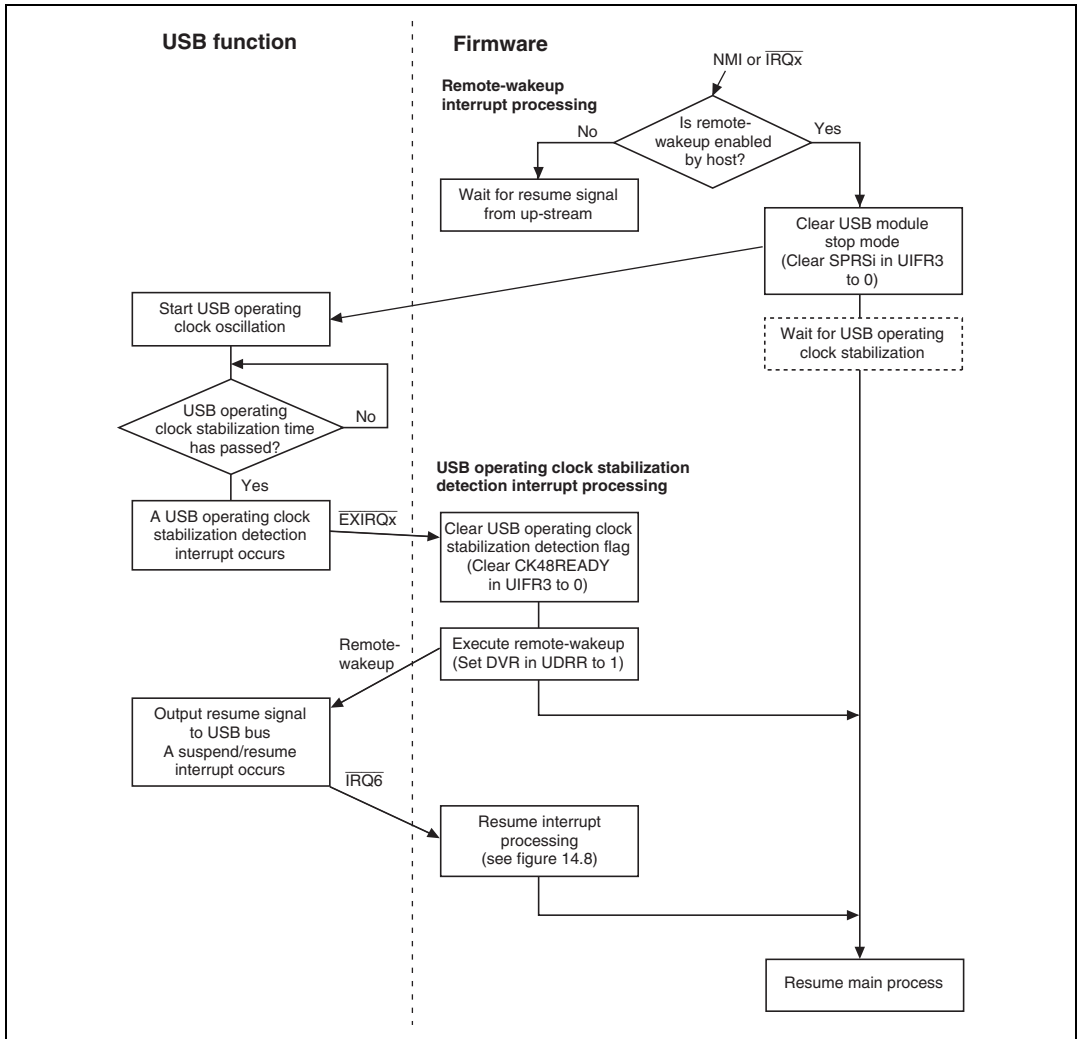
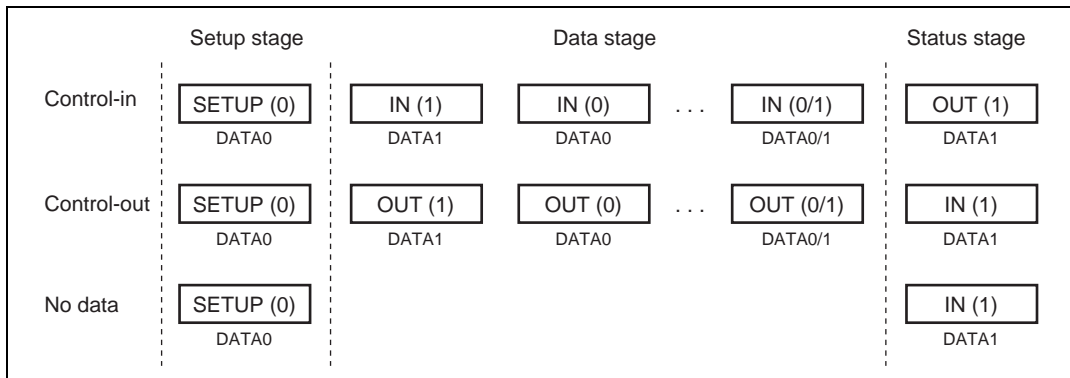


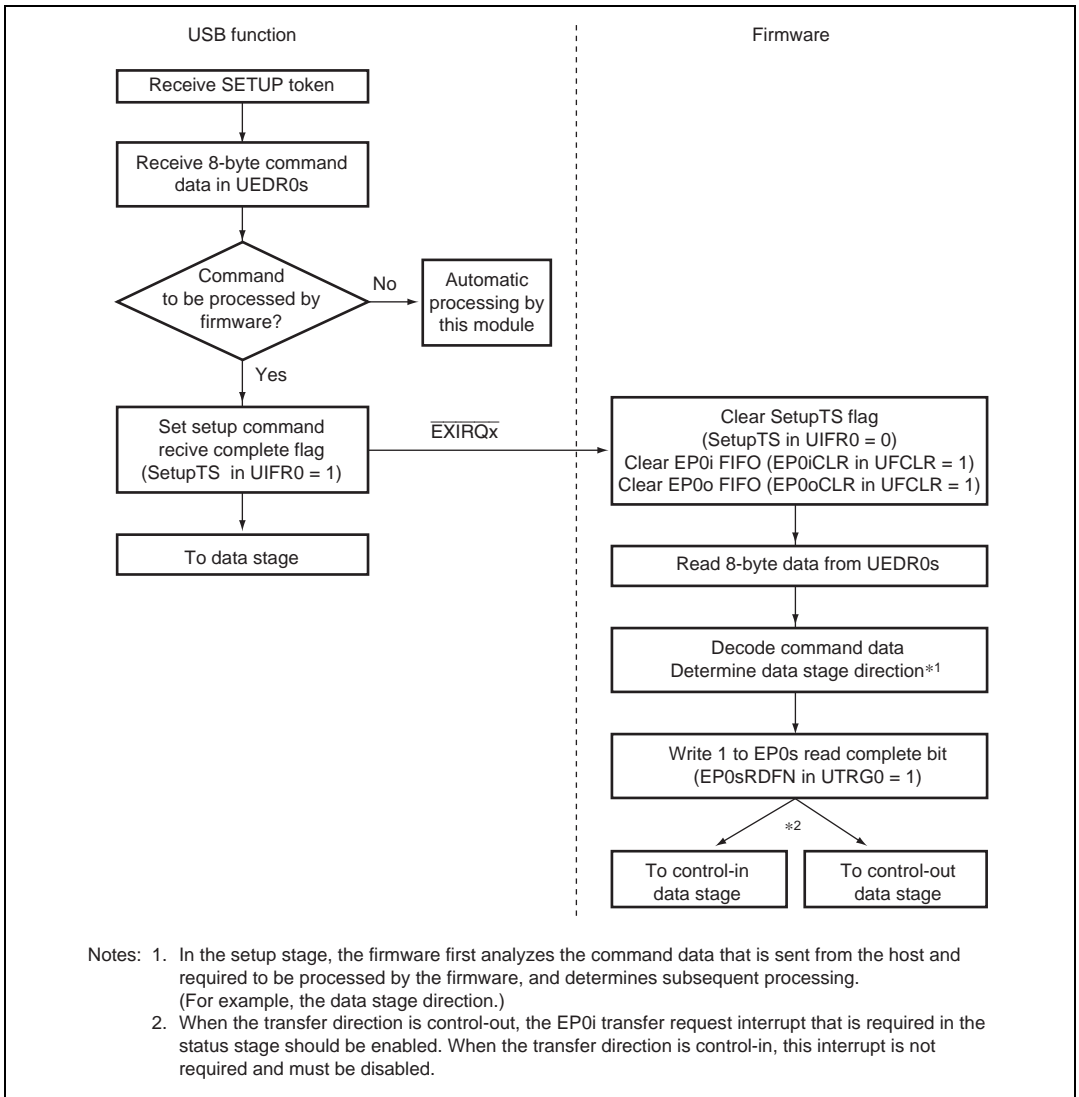
Figure 14.10 Example Flowchart of Remote-Wakeup Interrupt Processing

### 14.5.4 Control Transfer

The control transfer consists of three stages; setup, data (sometimes omitted), and status, as shown in figure 14.11. The data stage consists of multiple bus transactions. Figures 14.12 to 14.16 show operation flows in each stage.



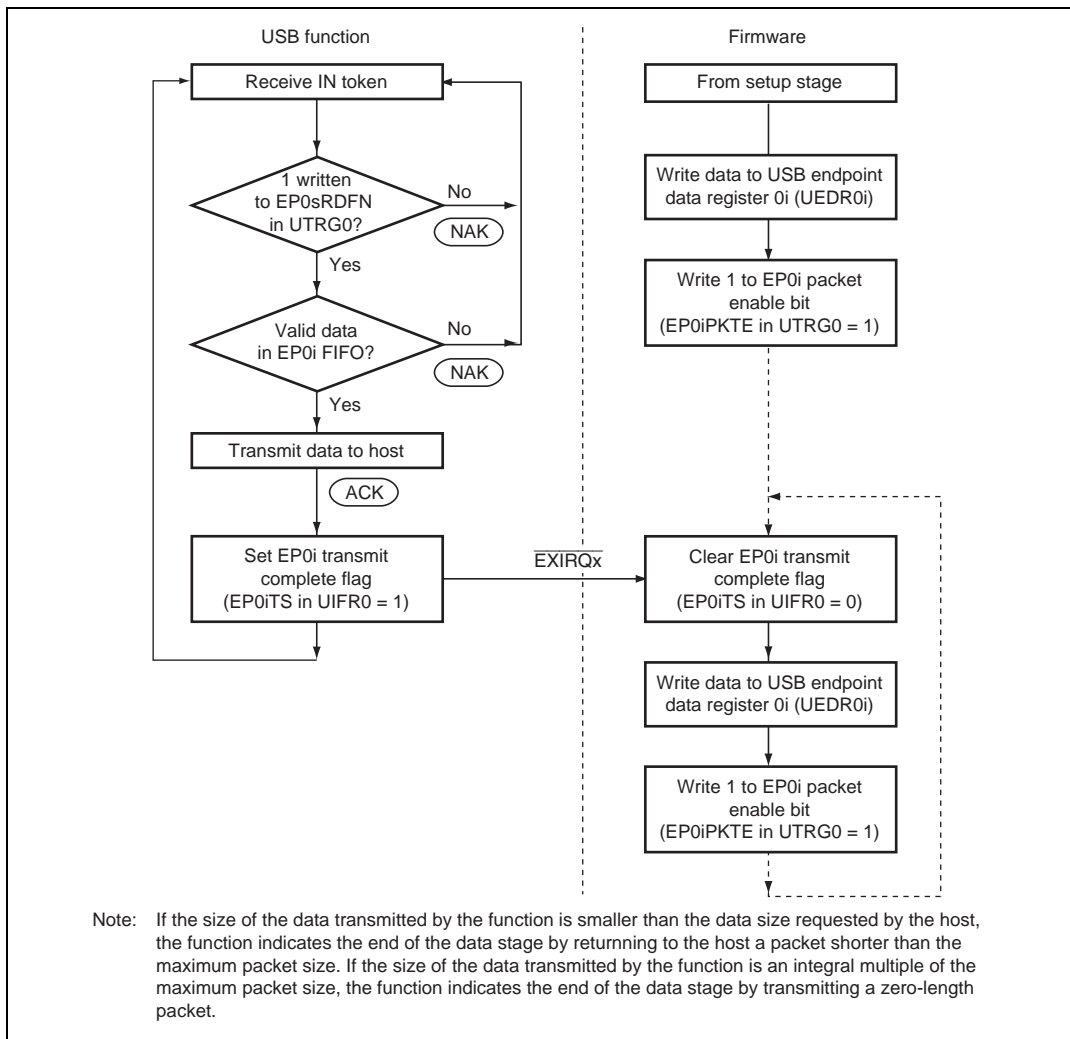
**Figure 14.11 Control Transfer Stage Configuration**

**(1) Setup Stage****Figure 14.12 Setup Stage Operation**

**(2) Data Stage (Control-In)**

The firmware first analyzes the command data that is sent from the host in the setup stage, and determines the subsequent data stage direction. If the result of command data analysis is that the data stage is in-transfer, one packet of data to be sent to the host is written to the FIFO. If there is more data to be sent, this data is written to the FIFO after the data written first has been sent to the host (EP0iTS in UIFR0 is set to 1).

The end of the data stage is identified when the host transmits an OUT token and the status stage is entered.

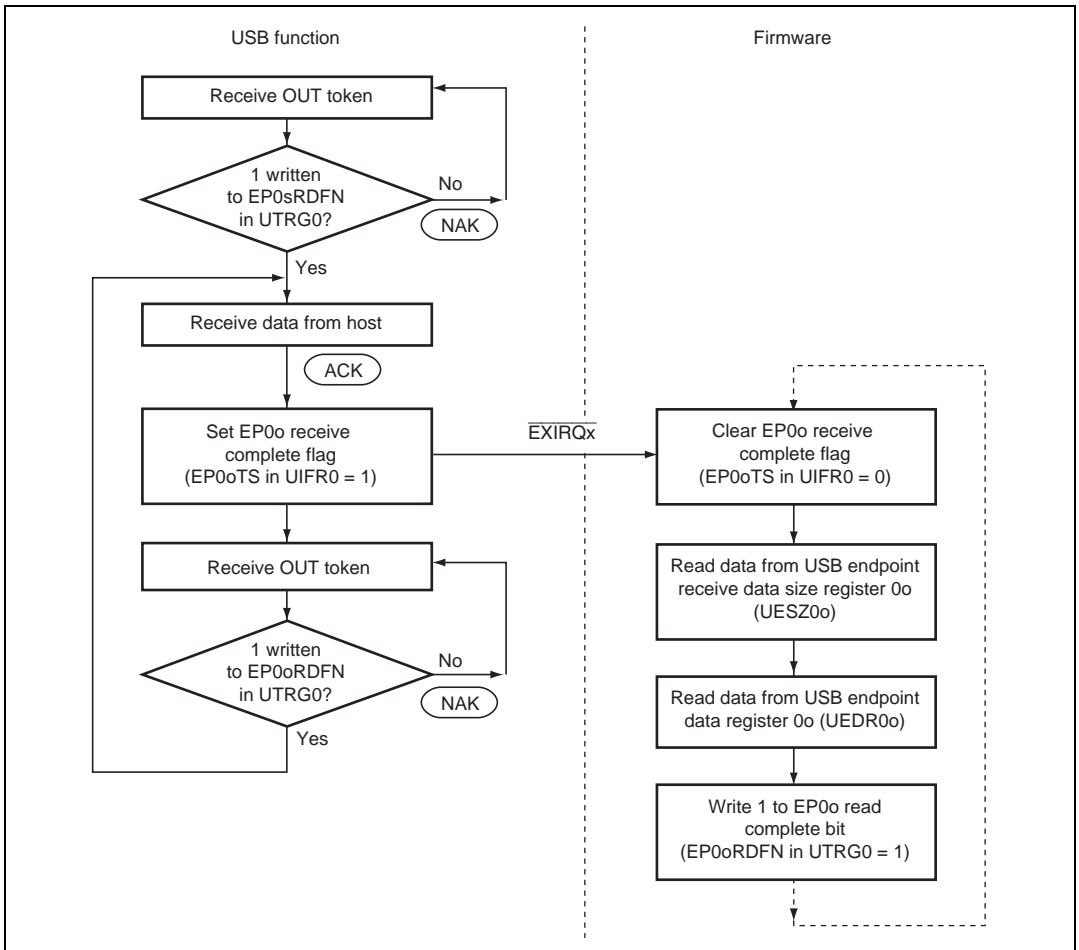


**Figure 14.13 Data Stage Operation (Control-In)**

### (3) Data Stage (Control-Out)

The firmware first analyzes the command data that is sent from the host in the setup stage, and determines the subsequent data stage direction. If the result of command data analysis is that the data stage is out-transfer, data from the host is waited for, and after data is received (EP0oTS in UIFR0 is set to 1), data is read from the FIFO. Next, the firmware writes 1 to the EP0o read complete bit, empties the receive FIFO, and waits for reception of the next data.

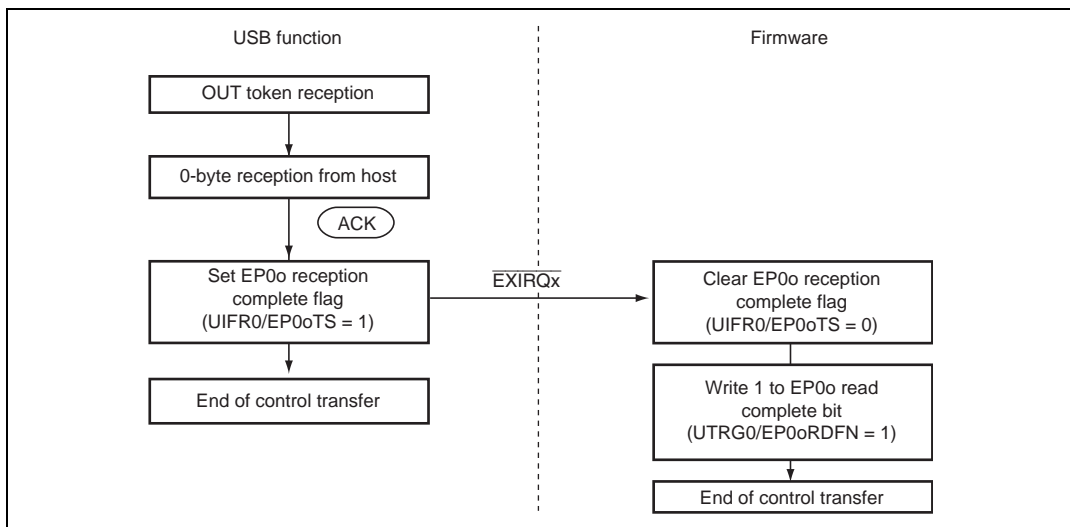
The end of the data stage is identified when the host transmits an IN token and the status stage is entered.



**Figure 14.14 Data Stage Operation (Control-Out)**

**(4) Status Stage (Control-In)**

The control-in status stage starts with an OUT token from the host. The firmware receives 0-byte data from the host, and ends control transfer.

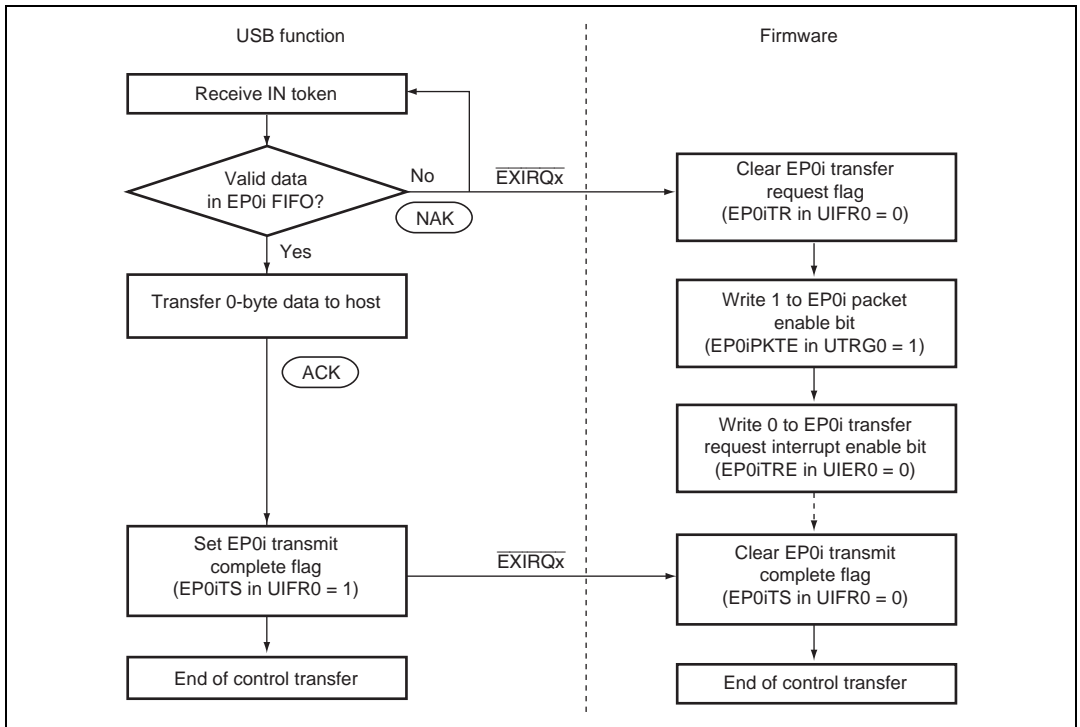


**Figure 14.15 Status Stage Operation (Control-In)**

**(5) Status Stage (Control-Out)**

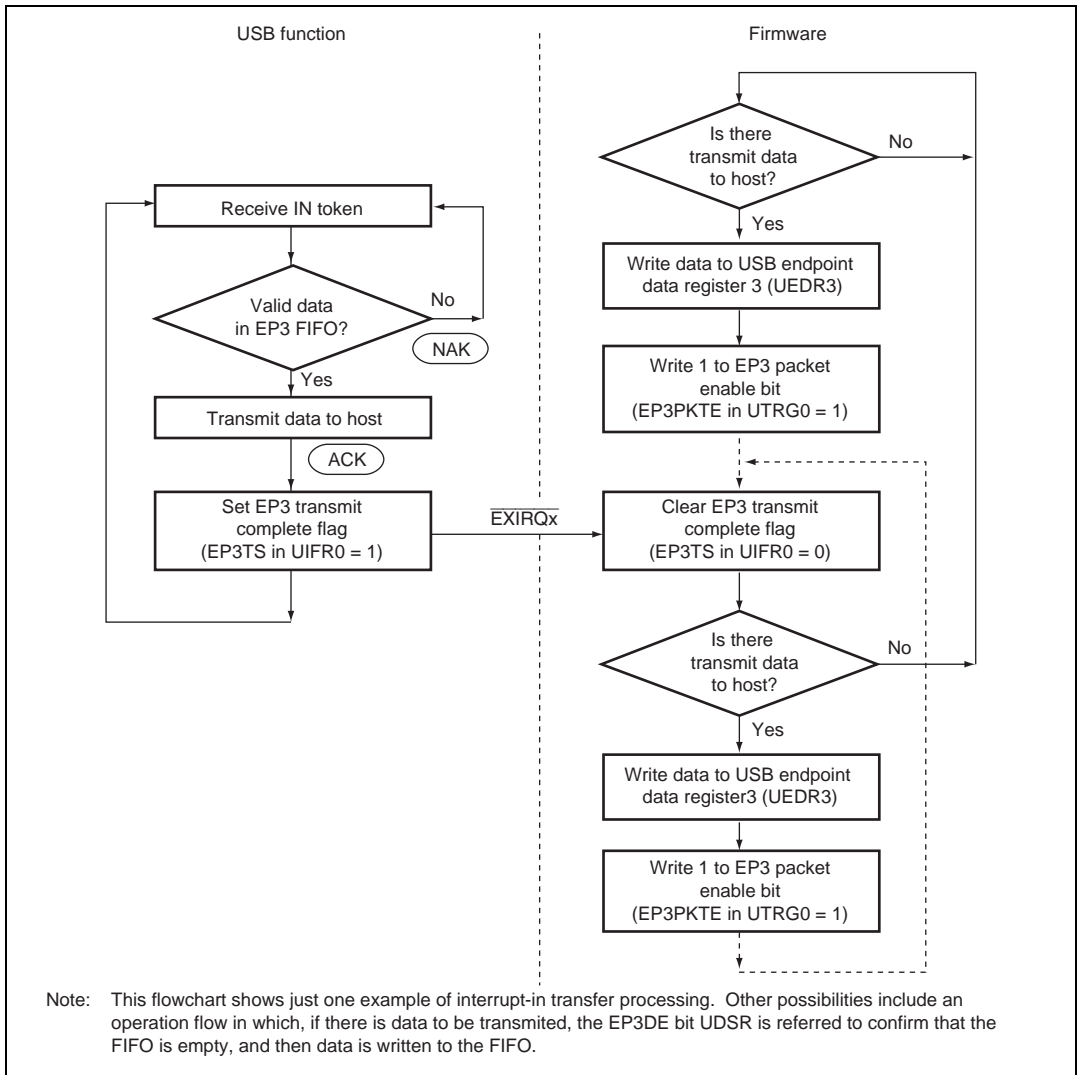
The control-out status stage starts with an IN token from the host. When an IN-token is received at the start of the status stage, there is not yet any data in the EP0i FIFO, and so an EP0i transfer request interrupt is generated. The firmware recognizes from this interrupt that the status stage has started. Next, in order to transmit 0-byte data to the host, 1 is written to the EP0i packet enable bit but no data is written to the EP0i FIFO. As a result, the next IN token causes 0-byte data to be transmitted to the host, and control transfer ends.

After the firmware has finished all processing relating to the data stage, 1 should be written to the EP0i packet enable bit.



**Figure 14.16 Status Stage Operation (Control-Out)**

## 14.5.5 Interrupt-In Transfer (Endpoint 3)



Note: This flowchart shows just one example of interrupt-in transfer processing. Other possibilities include an operation flow in which, if there is data to be transmitted, the EP3DE bit UDSR is referred to confirm that the FIFO is empty, and then data is written to the FIFO.

**Figure 14.17 EP3 Interrupt-In Transfer Operation**



### 14.5.6 Bulk-In Transfer (Dual FIFOs) (Endpoint 1)

EP1 has two 64-byte FIFOs, but the user can transmit data and write transmit data without being aware of this dual-FIFO configuration. However, one data write should be performed for one FIFO. For example, even if both FIFOs are empty, it is not possible to perform EP1PKTE at one time after consecutively writing 128 bytes of data. EP1PKTE must be performed for each 64-byte write.

When transmitting data to the host by bulk-in transfer, first enable the EP1 FIFO empty interrupt by writing 1 to EP1EMPTYE in UIER1. At first, both EP1 FIFOs are empty, and so an EP1 FIFO empty interrupt is generated immediately. The data to be transmitted is written to the data register using this interrupt. After the first transmit data write for one FIFO, the other FIFO is empty, and so the next transmit data can be written to the other FIFO immediately. When both FIFOs are full, EP1EMPTY is cleared to 0. If at least one FIFO is empty, UIFR1/EP1EMPTY is set to 1. When ACK is returned from the host after data transmission is completed, the FIFO used in the data transmission becomes empty. If the other FIFO contains valid transmit data at this time, transmission can be continued.

When transmission of all data has been completed, write 0 to UIER1/EP1EMPTYE and disable EXIRQ0 or EXIRQ1 interrupt requests.

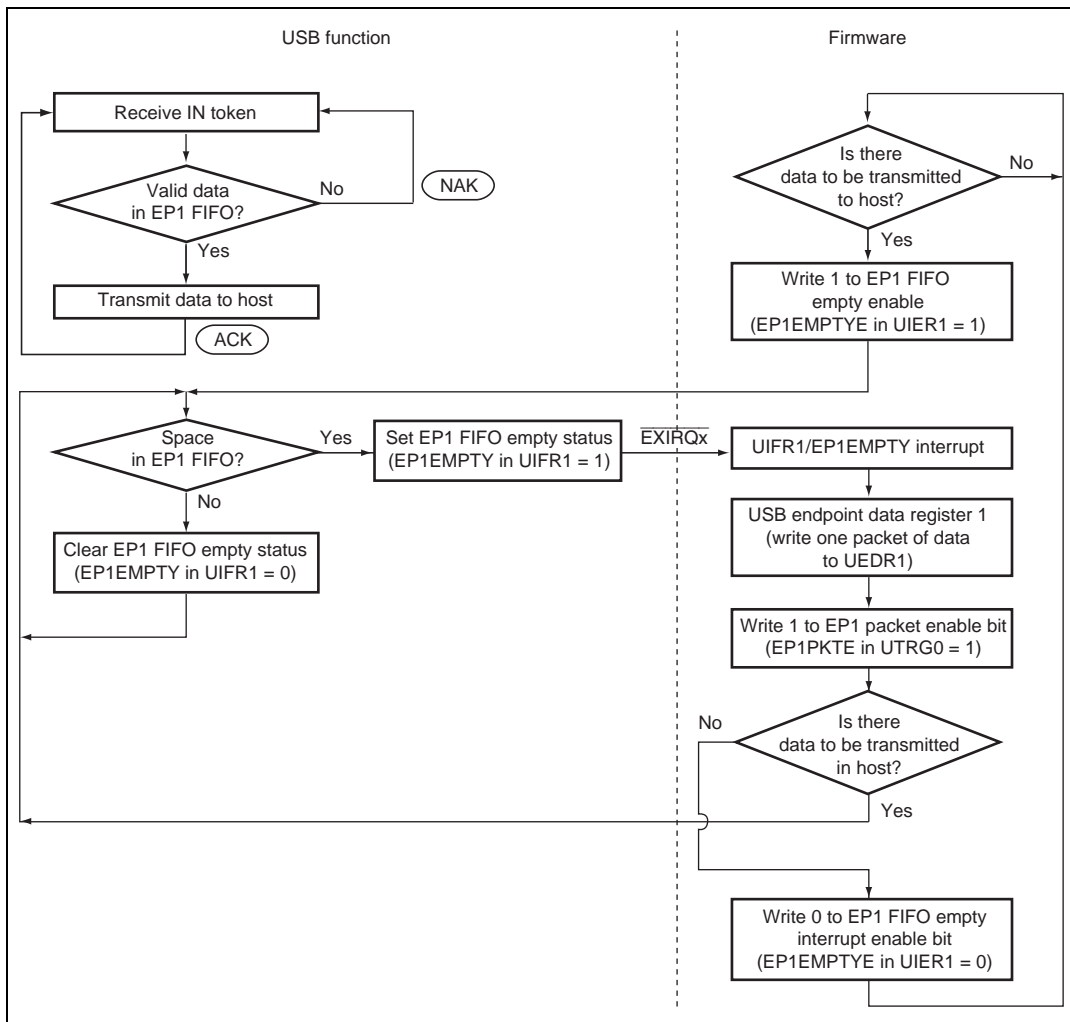
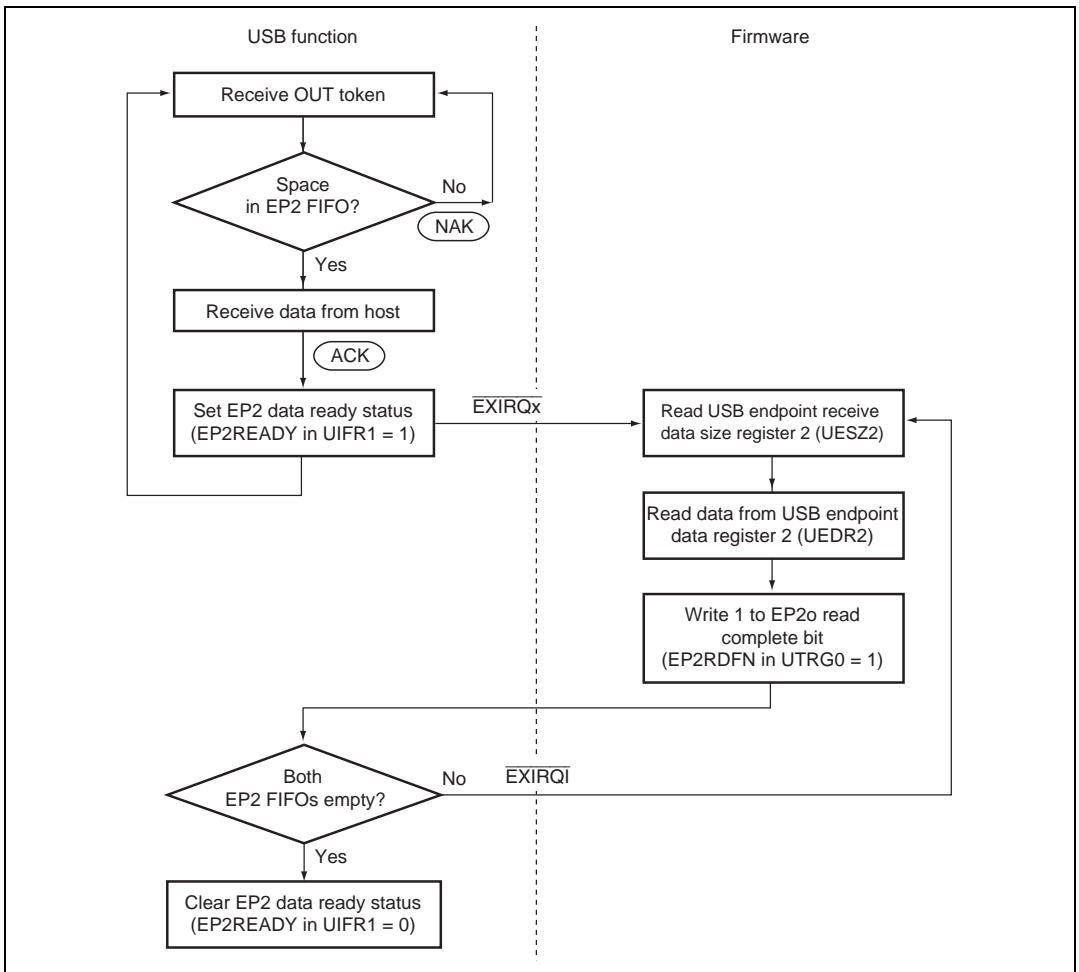


Figure 14.18 EP1 Bulk-In Transfer Operation

### 14.5.7 Bulk-Out Transfer (Dual FIFOs) (Endpoint 2)

EP2 has two 64-byte FIFOs, but the user can receive data and read receive data without being aware of this dual-FIFO configuration.

When one FIFO is full after reception is completed, the UIFR1/EP2READY bit is set. After the first receive operation into one of the FIFOs when both FIFOs are empty, the other FIFO is empty, and so the next packet can be received immediately. When both FIFOs are full, NAK is returned to the host automatically. When reading of the receive data is completed following data reception, 1 is written to the UTRG0/EP2RDFN bit. This operation empties the FIFO that has just been read, and makes it ready to receive the next packet.



**Figure 14.19 EP2 Bulk-Out Transfer Operation**

## 14.5.8 Processing of USB Standard Commands and Class/Vendor Commands

### (1) Processing of Commands Transmitted by Control Transfer

A command transmitted from the host by control transfer may require decoding and execution of command processing by the firmware. Whether or not command decoding is required by the firmware is indicated in table 14.5 below.

**Table 14.5 Command Decoding by Firmware**

<b>Decoding not Necessary by Firmware</b>	<b>Decoding Necessary by Firmware</b>
Clear Feature	Get Descriptor
Get Configuration	Synch Frame
Get Interface	Set Descriptor
Get Status	Class/Vendor command
Set Address	
Set Configuration	
Set Feature	
Set Interface	

If decoding is not necessary by the firmware, command decoding and data stage and status stage processing are performed automatically. No processing is necessary by the user. An interrupt is not generated in this case.

If decoding is necessary by the firmware, the USB function module stores the command in the EP0s FIFO. After normal reception is completed, the SetupTS flag in UIER0 is set and an interrupt request is generated from the  $\overline{\text{EXIRQx}}$  pin. In the interrupt routine, eight bytes of data must be read from the EP0s data register (UEDR0s) and decoded by the firmware. The necessary data stage and status stage processing should then be carried out according to the result of the decoding operation.

## 14.5.9 Stall Operations

### (1) Overview

This section describes stall operations in the USB function module. There are two cases in which the USB function module stall function is used:

- A. When the firmware forcibly stalls an endpoint for some reason
- B. When a stall is performed automatically within the USB function module due to a USB specification violation.

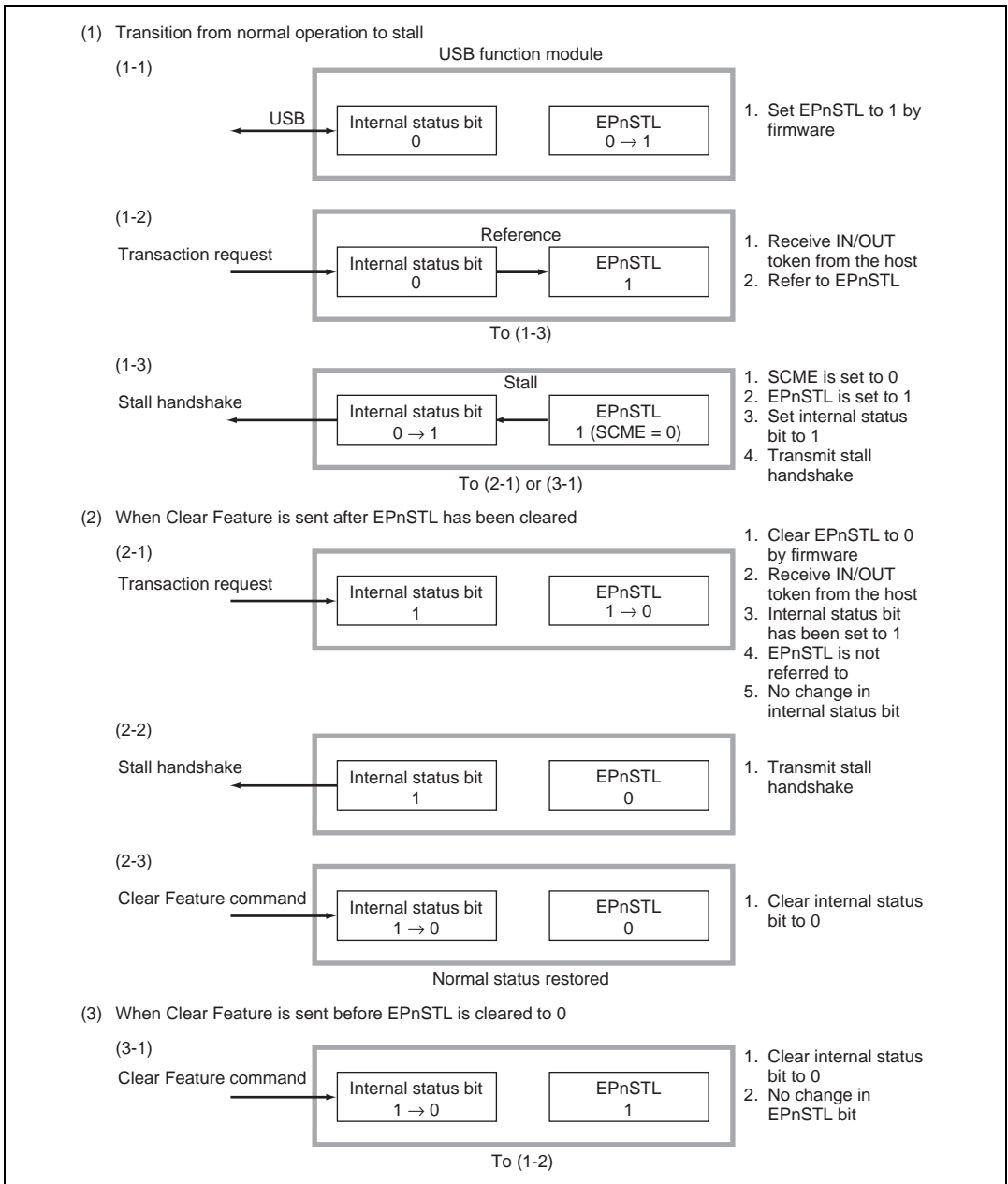
The USB function module has internal status bits that hold the status (stall or non-stall) of each endpoint. When a transaction is sent from the host, the module refers these internal status bits and determines whether to return a stall to the host. These bits cannot be cleared by the firmware; they must be cleared with a Clear Feature command from the host. However, the internal status bit for EP0 is cleared automatically at the reception of the setup command.

### (2) Forcible Stall by Firmware

The firmware uses the UESTL register to issue a stall request for the USB function module. When the firmware wishes to stall a specific endpoint, it sets the corresponding EPnSTL bit (1-1 in figure 14.20). The internal status bits are not changed at this time.

When a transaction is sent from the host for the endpoint for which the EPnSTL bit was set, the USB function module refers the internal status bit, and if this is not set, refers the corresponding EPnSTL bit (1-2 in figure 14.20). If the corresponding EPnSTL bit is not set, the internal status bit is not changed and the transaction is accepted. If the corresponding EPnSTL bit is set, the USB function module sets the internal status bit and returns a stall handshake to the host (1-3 in figure 14.20).

Once an internal status bit is set, it remains set until cleared by a Clear Feature command from the host, without regarding to EPnSTL. Even after a bit is cleared by the Clear Feature command (3-1 in figure 14.20), the USB function module continues to return a stall handshake while the EPnSTL bit is set, since the internal status bit is set each time a transaction is executed for the corresponding endpoint (1-2 in figure 14.20). To clear a stall, therefore, it is necessary for the corresponding EPnSTL bit to be cleared by the firmware, and also for the internal status bit to be cleared with a Clear Feature command (2-1 to 2-3 in figure 14.20).

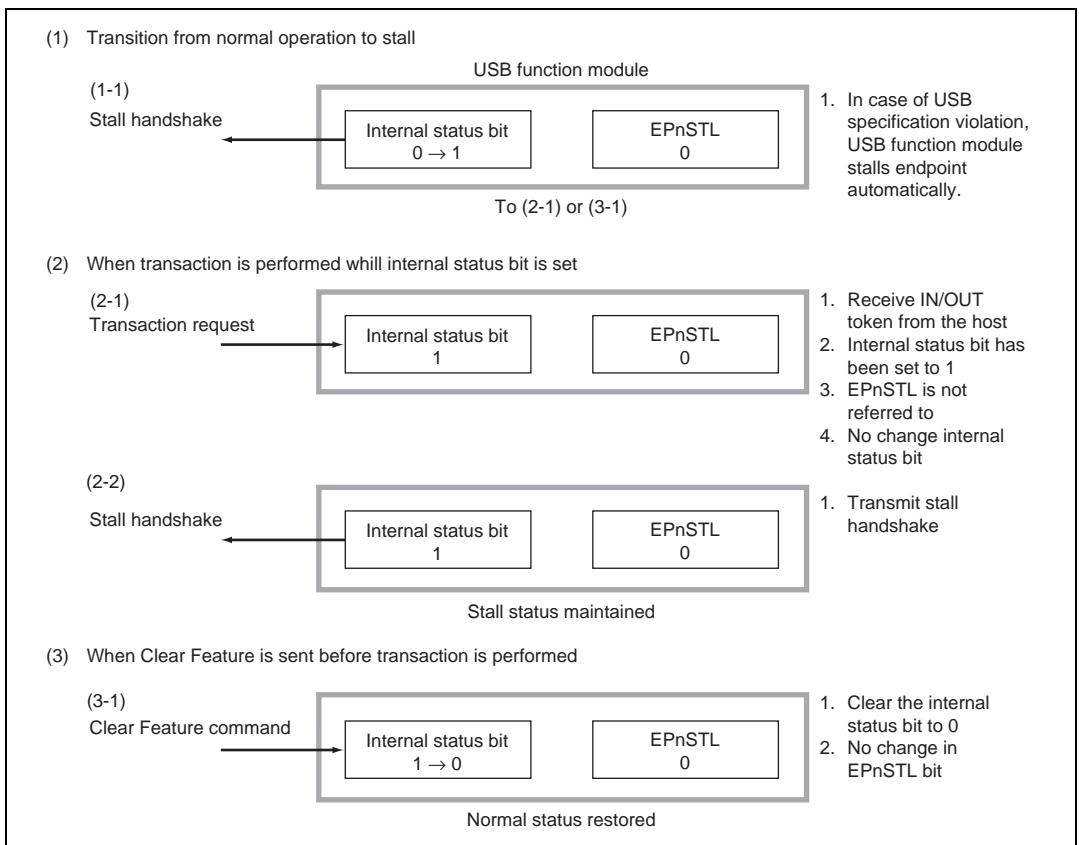


**Figure 14.20 Forcible Stall by Firmware**

### (3) Automatic Stall by USB Function Module

When a stall setting is made with the Set Feature command, when the information of this module differs from that returned to the host by the Get Descriptor, or in the event of a USB specification violation, the USB function module automatically sets the internal status bit for the corresponding endpoint without regarding to EPnSTL, and returns a stall handshake (1-1 in figure 14.21).

Once an internal status bit is set, it remains set until cleared by a Clear Feature command from the host, without regarding to EPnSTL. After a bit is cleared by the Clear Feature command, EPnSTL is referred (3-1 in figure 14.21). The USB function module continues to return a stall handshake while the internal status bit is set, since the internal status bit is set even if a transaction is executed for the corresponding endpoint (2-1 and 2-2 in figure 14.21). To clear a stall, therefore, the internal status bit must be cleared with a Clear Feature command (3-1 in figure 14.21). If set by the firmware, EPnSTL should also be cleared (2-1 in figure 14.21).



**Figure 14.21 Automatic Stall by USB Function Module**

## 14.6 DMA Transfer Specifications

Two methods of USB request and auto request are available for the DMA transfer of USB data.

### 14.6.1 DMAC Transfer by USB Request

#### (1) Overview

Only normal mode in full address mode (cycle steal mode) supports the transfer by a USB request of the on-chip DMAC. Endpoints that can be transferred by the on-chip DMAC are EP1 and EP2 in Bulk transfer (corresponding registers are UEDR1 and UEDR2). In DMA transfer, the USB module must be accessed as an external device in area 6. The USB module cannot be accessed as a device with external ACK (single-address transfer cannot be performed). 0-byte data transfer to EP2 is ignored even if the DMA transfer is enabled by setting the EP2T1 bit in UDMAR to 1.

#### (2) On-Chip DMAC Settings

The on-chip DMAC must be specified as follows: A USB request ( $\overline{\text{DREQ}}$  signal is used), activated by low-level input, byte size, full-address mode transfer, and the DTA bit in DMABCR = 1. After completing the DMA transfer of specified times, the DMAC automatically stops. Note, however, that the USB module keeps the  $\overline{\text{DREQ}}$  signal low while data to be transferred by the on-chip DMAC remains regardless of the DMAC status.

#### (3) EP1 DMA Transfer

The EP1T1 bit in UDMAR enables the DMA transfer. The EP1T0 bit in UDMAR specifies the  $\overline{\text{DREQ}}$  signal to be used by the DMA transfer. When 1 is written to the EP1T1 bit, the  $\overline{\text{DREQ}}$  signal is driven low if at least one of EP1 data FIFOs is empty; the  $\overline{\text{DREQ}}$  signal is driven high if both EP1 data FIFOs are full.

##### (a) EP1PKTE in UTRG0

When DMA transfer is performed on EP1 transmit data, the USB module automatically performs the same processing as writing 1 to EP1PKTE if one data FIFO (64 bytes) becomes full.

Accordingly, to transfer data of integral multiples of 64 bytes, the user needs not to write 1 to EP1PKTE. To transfer data of less than 64 bytes, the user must write 1 to EP1PKTE using the DMA transfer end interrupt of the on-chip DMAC. If the user writes 1 to EP1PKTE in cases other than the case when data of less than 64 bytes is transferred, excess transfer occurs and correct operation cannot be guaranteed.

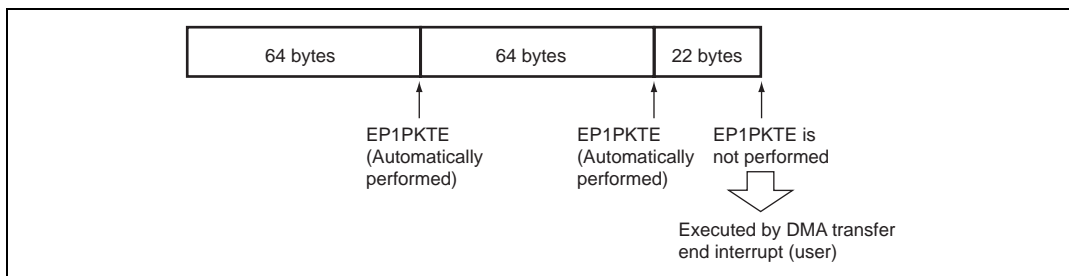
Figure 14.22 shows an example for transmitting 150 bytes of data from EP1 to the host. In this case, internal processing as the same as writing 1 to EP1PKTE is automatically performed twice. This kind of internal processing is performed when the currently selected data FIFO becomes full.



Accordingly, this processing is automatically performed only when 64-byte data is sent. This processing is not performed automatically when data less than 64 bytes is sent.

#### (b) EP1 DMA transfer procedure

1. Set the bits EP1T1 and EP1T0 in UDMAR.
2. Set DMAC (specifies the number of transfers in DMAC to transmit 150 bytes of data).
3. Activate DMAC.
4. Perform DMA transfer.
5. Write 1 to the EP1PKTE bit in UTRG0 by a DMA transfer end interrupt.



**Figure 14.22 EP1PKTE Operation in UTRG0**

#### (4) EP2 DMA Transfer

The EP2T1 bit in UDMAR enables the DMA transfer. The EP2T0 bit in the UDMAR specifies the DREQ signal to be used by the DMA transfer. When 1 is written to the EP2T1 bit, the DREQ signal is driven low if at least one of EP2 data FIFOs is full (ready state); the DREQ signal is driven high if both EP2 data FIFOs are empty when all receive data items are read.

##### (a) EP2RDFN in UTRG0

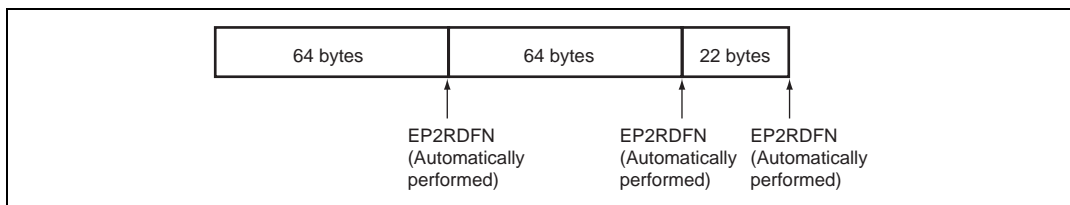
When DMA transfer is performed on EP2 receive data, do not write 1 to EP2RDFN after one data FIFO (64 bytes) has been read. In data transfer other than DMA transfer, the next data cannot be read after one data FIFO (64 bytes) has been read unless 1 is written to EP2RDFN. While in DMA transfer, the USB module automatically performs the same processing as writing 1 to EP2RDFN if the currently selected data FIFO becomes empty. Accordingly, in DMA transfer, the user needs not to write 1 to EP2RDFN. If the user writes 1 to EP2RDFN in DMA transfer, excess transfer occurs and correct operation cannot be guaranteed.

Figure 14.23 shows an example of EP2 receiving 150 bytes of data from the host. In this case, internal processing as the same as writing 1 to EP2RDFN is automatically performed three times. This kind of internal processing is performed when the currently selected data FIFO becomes empty. Accordingly, this processing is automatically performed both when 64-byte data is sent and when data less than 64 bytes is sent.

**(b) EP2 DMA transfer procedure**

Perform DMAC transfer in 1 packet units. After setting the EP2READY flag, check the size of data received from the host and then set the data size as the number of DMAC transfers.

1. Set the bits EP2T1 and EP2T0 in UDMAR.
2. Wait for the EP2READY flag in UIFR1 to be set.
3. Set DMAC.  
Read the value in UESZ2 and specifies the size of received data (not more than 64 bytes) as the number of transfers.
4. Activate DMAC.
5. Perform DMA transfer (not more than 64 bytes).
6. Wait for DMA transfer end.
7. Repeat steps 2 to 6.



**Figure 14.23 EP2RDFN Operation in UTRG0**

## 14.6.2 DMA Transfer by Auto-Request

### (1) Overview

Burst mode transfer or cycle steal transfer can be selected for the on-chip DMAC auto-request transfer. Endpoints that can be transferred by the on-chip DMAC are all registers (UEDR0s, UEDR0i, UEDR0o, UEDR1, UEDR2, UEDR3). Confirm flags and interrupts corresponding to each data register before activating the DMA. As UDMAR is not used in auto-request mode, set UDMAR to H'00.

### (2) On-Chip DMAC Settings

The on-chip DMAC must be specified as follows: Auto-request, byte size, full-address mode transfer, and number of transfers equal to or less than the maximum packet size of the data register. After completing the DMAC transfers of specified time, the DMAC automatically stops.

### (3) EP0, EP1, or EP3 DMA Transfer

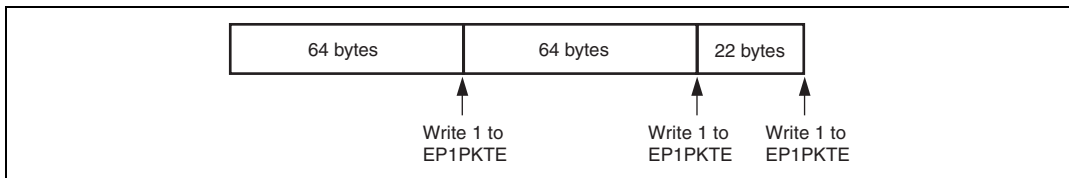
#### (a) EPnPKTE Bits of UTRG0 (n = 0i, 1, or 3)

Note that 1 is not automatically written to EPnPKTE in case of auto-request transfer. Always write 1 to EPnPKTE by the CPU. The following example shows when 150-byte data is transmitted from EP1 to the host. In this case, 1 should be written to EP2PKTE three times as shown in figure 14.24.

#### (b) EP1 DMA Transfer Procedure

The DMAC transfer unit should be one packet. Therefore, set the number of transfers so that it is equal to or less than the maximum packet size of each endpoint.

1. Confirm that UIFR1/EP1EMPTY flag is 1.
2. DMAC settings for EP1 data transfer (such as auto-request and address setting).
3. Set the number of transfers for 64 bytes (the maximum packet size or less) in the DMAC.
4. Activate the DMAC (write 1 to DTE after reading DTE as 0).
5. DMA transfer.
6. Write 1 to the UTRG0/EP1PKTE bit after the DMA transfer is completed.
7. Repeat steps 1 to 6 above.
8. Confirm that UIFR1/EP1EMPTY flag is 1.
9. Set the number of transfer for 22 bytes in the DMAC.
10. Activate the DMAC (write 1 to DTE after reading DTE as 0).
11. DMA transfer.
12. Write 1 to the UTRG0/EP1PKTE bit after the DMA transfer is completed.



**Figure 14.24 EP1PKTE Operation in UTRG0 (Auto-Request)**

### (4) EP0 or EP2 DMA Transfer

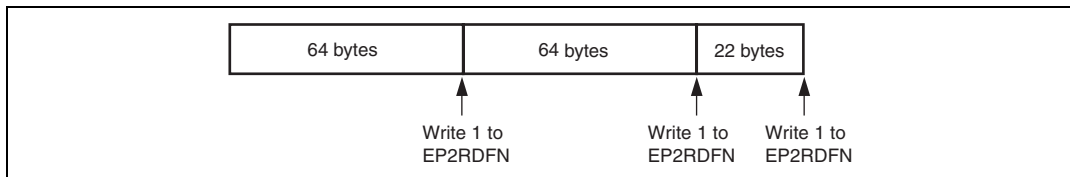
#### (a) EPnRDFN Bits of UTRG0 (n = 0o or 2)

Note that 1 is not automatically written to EPnRDFN in case of auto-request transfer. Always write 1 to EPnRDFN by the CPU. The following example shows when EP2 receives 150-byte data from the host. In this case, 1 should be written to EP2RDFN three times as shown in figure 14.25.

**(b) EP2 DMA Transfer Procedure**

The DMAC transfer unit should be one packet. Therefore, set the number of transfers so that it is equal to or less than the maximum packet size of each endpoint.

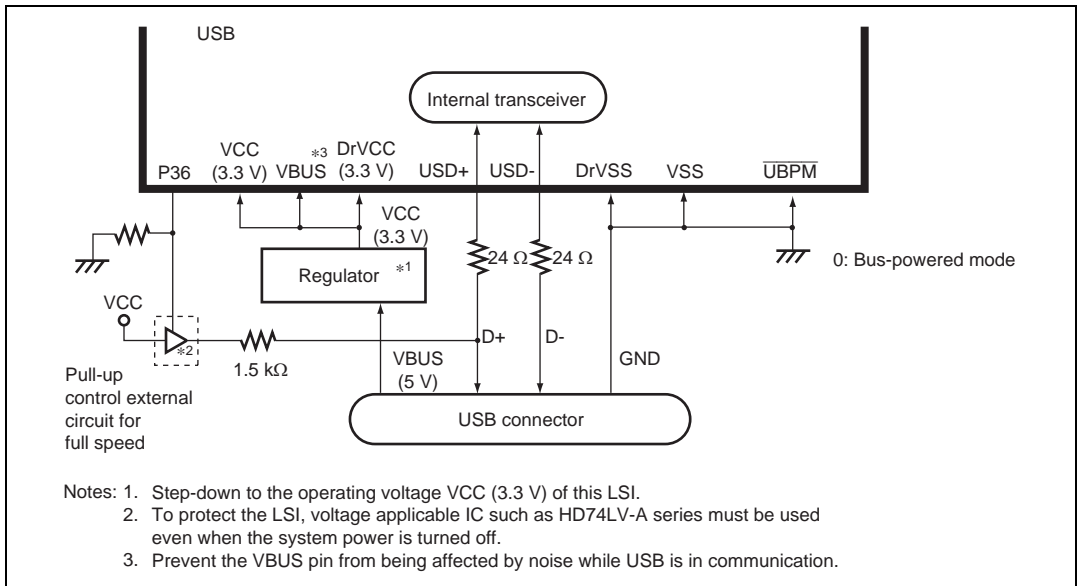
1. Wait for the UIFR1/EP2READY flag to be set.
2. DMAC settings for EP2 data transfer (such as auto-request and address setting). Read value of UESZ2 and specify number of transfers to match size of received data (64 bytes or less).
3. Activate the DMAC (write 1 to DTE after reading DTE as 0).
4. DMA transfer (transfer of 64 bytes or less).
5. Write 1 to the UTRG0/EP2RDFN bit after the DMA transfer is completed.
6. Repeat steps 1 to 5 above.



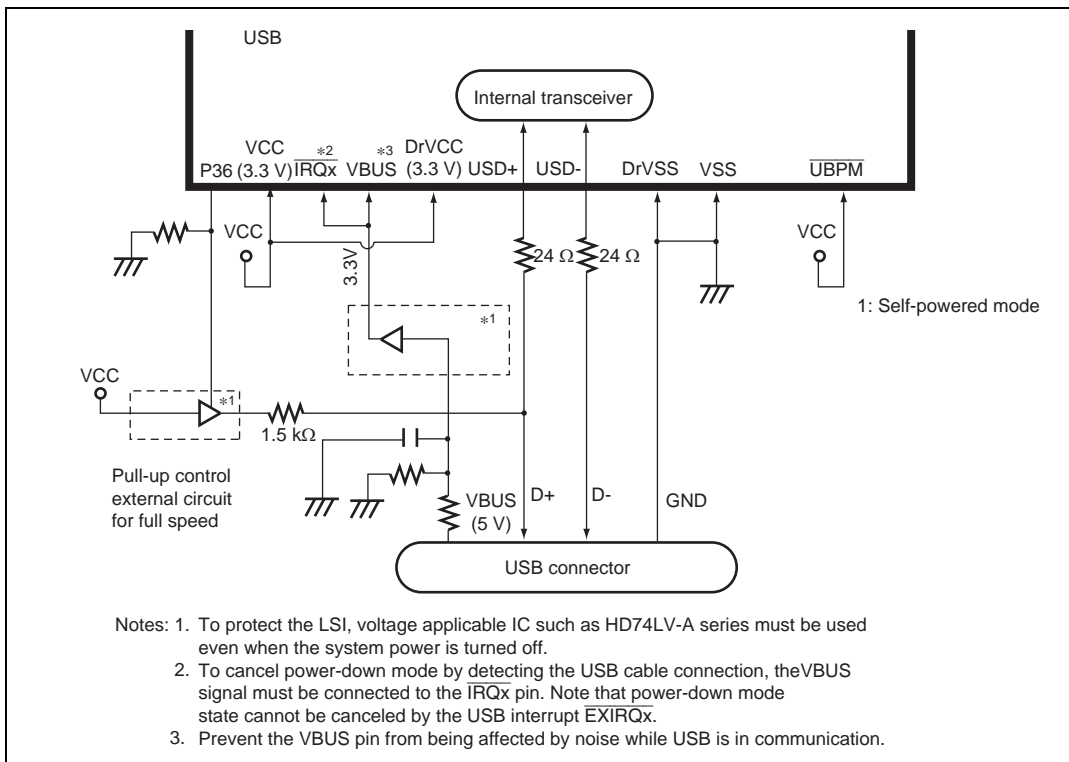
**Figure 14.25 EP2RDFN Operation in UTRG0 (Auto-Request)**

## 14.7 USB External Circuit Example

Figures 14.26 and 14.27 show the USB external circuit examples of this LIS.



**Figure 14.26 USB External Circuit in Bus-Powered Mode**



**Figure 14.27 USB External Circuit in Self-Powered Mode**

## 14.8 Usage Notes

### 14.8.1 Emulator Usage Notes

1. If UEDR0o and UEDR2 are displayed using the I/O register window function, or the like, the EP0o FIFO or EP2 FIFO read pointer will not operate properly, preventing UEDR0o, UESZ0o, UEDR2, and UESZ2 from being read correctly. Therefore, UEDR0o and UEDR2 should not be displayed.
2. In the E6000, since the USB module is mounted on the external extended board and accessed as an external module, there are some limitations as shown below. These limitations do not apply to the E10A or to product chips.
  - USB operation is not supported in the H8S/2218 Group's mode 7 (single-chip mode).
  - When using the USB module in the H8S/2218 Group's mode 6 (on-chip ROM-enabled mode) or the H8S/2212 Group's mode 7 (single-chip mode),  $\overline{CS6}$  and A9 to A0 are input pins in the initial status. Therefore,  $\overline{CS6}$  and A9 to A0 must be set as output pins (= B'0010) by setting P72DDR to 1, AE3 to AE0 to B'0010, and PC7DDR to PC0DDR to H'FF before accessing the USB module.
  - When using the USB module in the H8S/2218 Group's modes 4 and 5 (on-chip ROM-disabled mode),  $\overline{CS6}$  and A9 to A8 must be set as output pins by setting P72DDR to 1 and AE3 to AE0 to B'0010.

### 14.8.2 Bus Interface

The USB module's interface is based on the bus specifications of external area 6. Accordingly, before accessing the USB module, area 6 must be specified as having an 8-bit bus width and 3-state access using the bus controller register.

Address H'C00100 to H'DFFFFFF is for USB reserved area and thus access prohibited.

### 14.8.3 Operating Frequency

The main clock of this LSI must be 24 MHz or 16 MHz. This 24-MHz main clock, used as base clock, is doubled in the on-chip PLL circuit or this 16-MHz main clock, also used as base clock, is tripled in the on-chip PLL circuit, to generate the 48-MHz USB operating clock. Since the USB module does not support medium-speed mode, sleep mode, watch mode, subactive mode, and subsleep mode, make sure to use full-speed mode.

#### 14.8.4 Setup Data Reception

The following must be noted for the EP0s FIFO used to receive 8-byte setup data. The USB is designed to always receive setup commands. Accordingly, write from the UDC has higher priority than read from the LSI. If the reception of the next setup command starts while the LSI is reading data after completing reception, this data read from the LSI is forcibly cancelled and the next setup command write starts. After the next setup command write, data read from the LSI is thus undefined. Read operation is forcibly disabled because data cannot be guaranteed if DP-RAM used as FIFO accesses the same address for write and read.

#### 14.8.5 FIFO Clear

If the USB cable is disconnected during communication, old data may be contained in the FIFO. Accordingly, FIFOs must be cleared immediately after USB cable connection. In addition, after bus reset, all FIFOs must also be cleared. Note, however, that FIFOs that are currently used for data transfer to or from the host must not be cleared.

#### 14.8.6 $\overline{\text{IRQ6}}$ Interrupt

A suspend/resume interrupt requested by  $\overline{\text{IRQ6}}$  must be specified as falling-edge sensitive.

#### 14.8.7 Data Register Overread or Overwrite

When the CPU reads or writes to data registers, the following must be noted:

- Transmit data registers (UEDR0i, UEDR3, UEDR1)  
Data to be written to the transmit data registers must be within the maximum packet size. For the transmit data register of EP1 having a dual-FIFO configuration, data to be written at any time must be within the maximum packet size. In this case, after a data write, the FIFO is switched to the other FIFO, enabling a further data write, when the PKTE bit in UTRG0 is set to 1. Accordingly, data of size corresponding to two FIFOs must not be written to the transmit data registers at a time.
- Receive data registers (UEDR0o, UEDR2)  
Receive data registers must not read a data size that is greater than the effective size of the read data item. In other words, receive data registers must not read data with data size larger than that specified by the receive data size register. For the receive data register of EP2 having a dual-FIFO configuration, data to be read at any time must be within the maximum packet size. In this case, after reading the currently selected FIFO, set the RDFN bit in UTRG to 1. This switches the FIFO to the other FIFO and updates the receive data size, enabling the next data read. In addition, if there is no receive data in a FIFO, data must not be read. Otherwise, the



pointer that controls the internal module FIFO is updated and correct operation cannot be guaranteed.

### 14.8.8 Reset

— The manual reset during USB communication operations must not be executed, since the LSI may stop with the state of USD+ and USD- pins maintained.

This USB module uses synchronous reset for some registers. The reset state of these registers must be cancelled after the clock oscillation stabilization time has passed. At initialization, reset must be cancelled using the following procedure:

1. Cancel the USB module stop 1: Clear the USBSTOP1 bit in EXMDLSTP to 0.
2. Select the USB operating clock: Write 1 to the UCKS3 to UCKS0 bits in UCTLR.
3. Cancel the USB module stop 2: Clear the MSTPB0 bit in MSTPCRB to 0.
4. Wait for the USB operating clock stabilization: Wait until the CK48READY bit in UIFR3 is set to 1.
5. Cancel the USB interface reset state: Clear the UIFRST bit in UCTLR to 0.
6. Cancel the UDC core reset state: Clear the UDCRST bit in UCTLR to 0.

For details, see the flowcharts in section 14.5.1, Initialization and section 14.5.2, USB Cable Connection/Disconnection.

— The USB registers are not initialized when the watchdog timer (WDT) triggers a power-on reset. Therefore, the USB may not operate properly after a power-on reset is triggered by the WDT due to CPU runaway or a similar cause. (If a power-on reset is triggered by input of a power-on reset signal from the  $\overline{\text{RES}}$  pin, the USB registers are initialized and there is no problem.) Consequently, an initialization routine should be used to write the initial values listed below to the following three registers, thereby ensuring that all the USB registers are properly initialized, immediately following a reset.

UCTLR = H'03, UIER3 = H'80, UIFR3 = H'00

### 14.8.9 EP0 Interrupt Sources Assignment

EP0 interrupt sources assigned to bits 3 to 0 in UIFR0 must be assigned to the same interrupt signal ( $\overline{\text{EXIRQx}}$ ) by setting UISR0. There are no other restrictions on interrupt sources.

### 14.8.10 Level Shifter for VBUS and $\overline{\text{IRQx}}$ Pins

The VBUS and  $\overline{\text{IRQx}}$  pins of this USB module must be connected to the USB connector's VBUS pin via a level shifter. This is because the USB module has a circuit that operates by detecting USB cable connection or disconnection.

Even if the power of the device incorporating this USB module is turned off, 5-V power is applied to the USB connector's VBUS pin while the USB cable is connected to the device set. To protect the LSI from destruction, use a level shifter such as the HD74LV-A Series, which allows voltage application to the pin even when the power is off.

### 14.8.11 USB Endpoint Data Read and Write

To write data to an USB endpoint data register (UEDR0i, UEDR1, or UEDR3) on the transmit side using a CPU word or longword transfer instruction, the size of data to be written must be smaller than the size of data that is to be transmitted.

For example, when 7-byte data is transferred to the host, 8-byte data is sent to the host if data is written twice by the longword transfer instructions or if data is written four times by the word transfer instructions. To write 7-byte data correctly, data must be written once by a longword transfer instruction, once by a word transfer instruction, and once by a byte transfer instruction, or data must be written three times by a word transfer instruction and once by a byte transfer instruction.

To read data from the USB endpoint data register (UEDR0o or UEDR2) on the receive side, the correct size of data must be read. In this case, the data size is specified by the USB endpoint receive size register (UESZ0o or UESZ2).

To execute DMA transfer on data in the USB endpoint data register using the on-chip DMAC, byte transfer must be used. In word transfer, odd-byte data cannot be transferred. Word transfer is thus disabled.

### 14.8.12 Restrictions on Entering and Canceling Power-Down Mode

Before entering the power-down mode, set the USB module stop 2 state. The UDC core must not be reset.

To access the USB module after canceling power-down mode, cancel the USB module stop 2 state and wait for the USB operating clock (48 MHz) stabilization time.

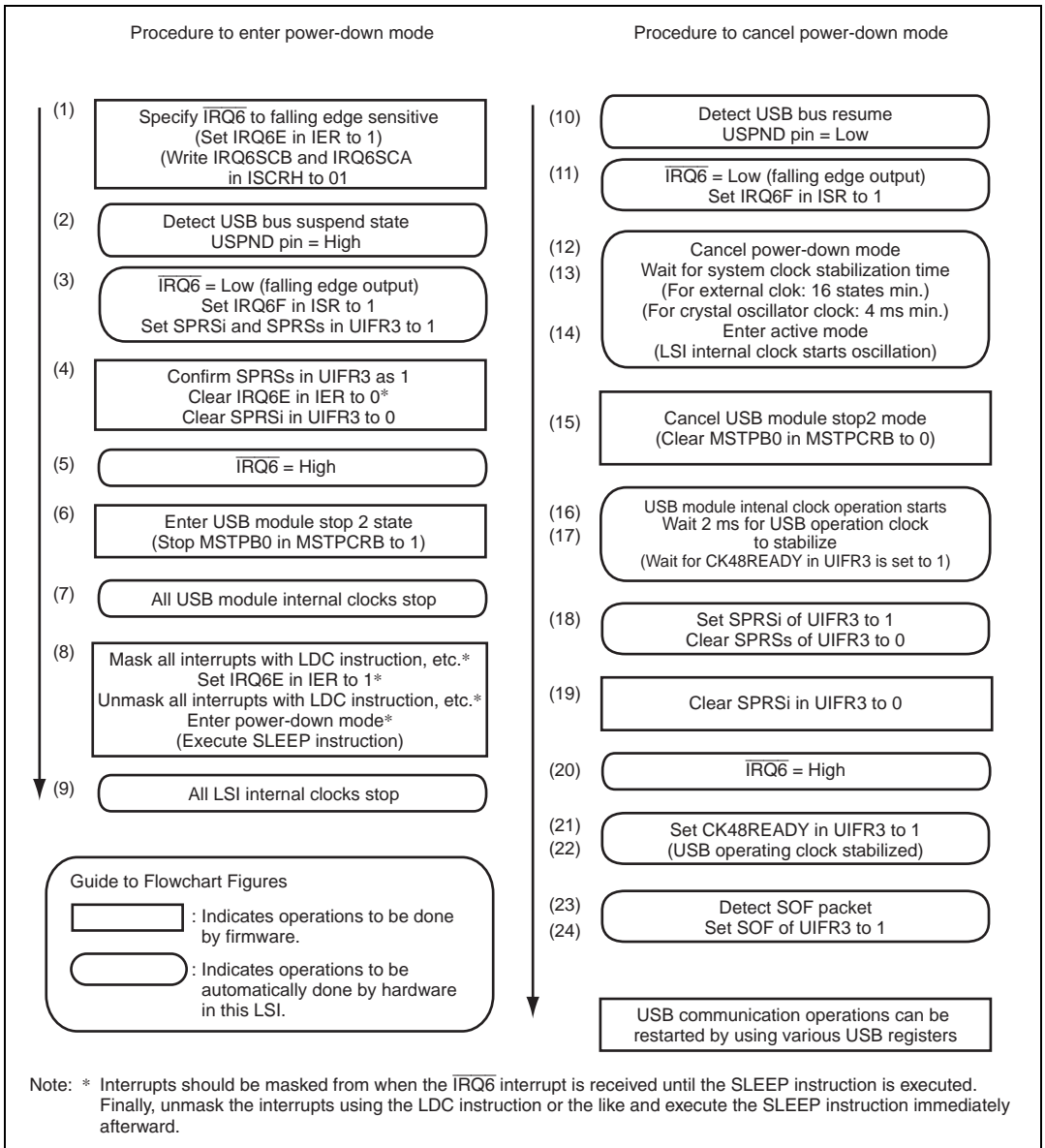


Figure 14.28 Flowchart

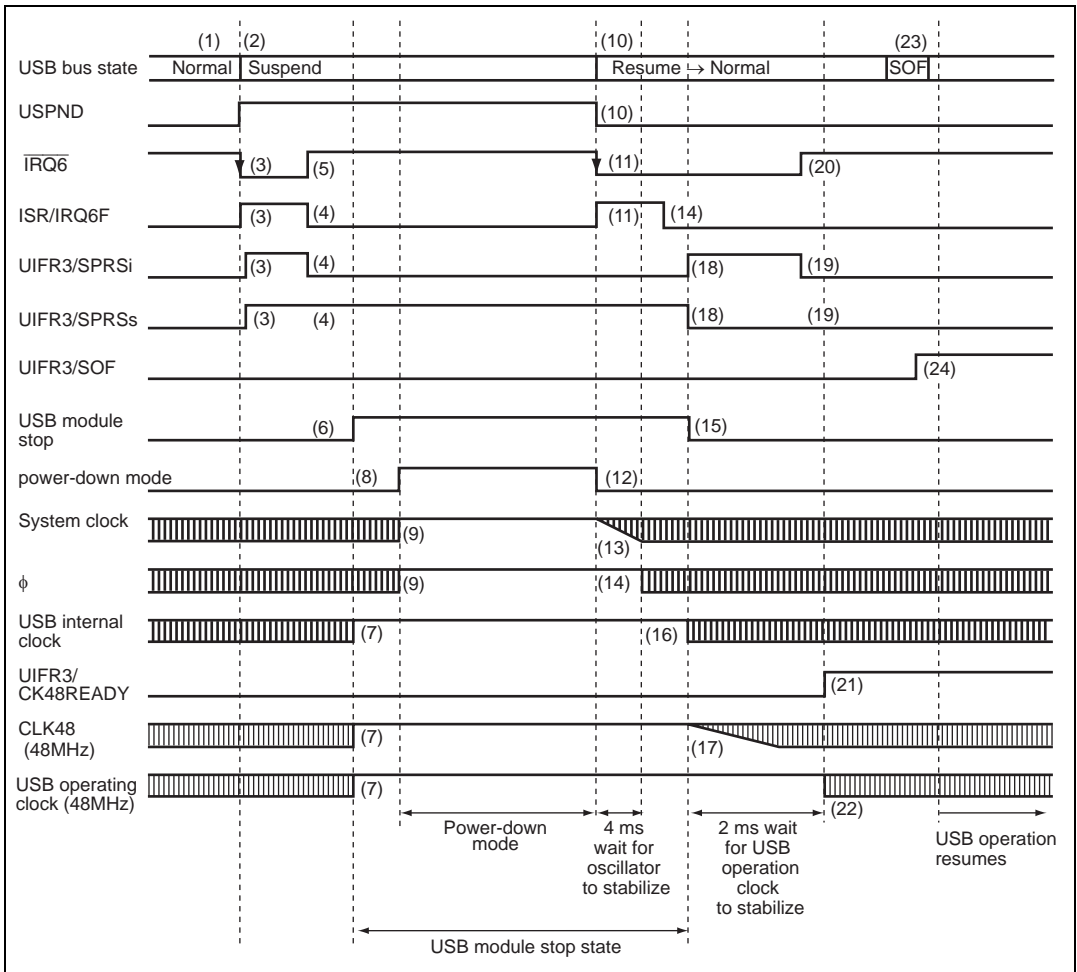


Figure 14.29 Timing Chart

### 14.8.13 USB External Circuit Example

The USB external circuit examples are used for reference only. In actual board design, carefully check the system operation.

In addition, the USB external circuit examples cannot guarantee the correct system operation. The user must individually take measures against external surges or ESD noise by incorporating protective diodes or other components if necessary.

### 14.8.14 Pin Processing when USB Not Used

Pin processing should be performed as follows.

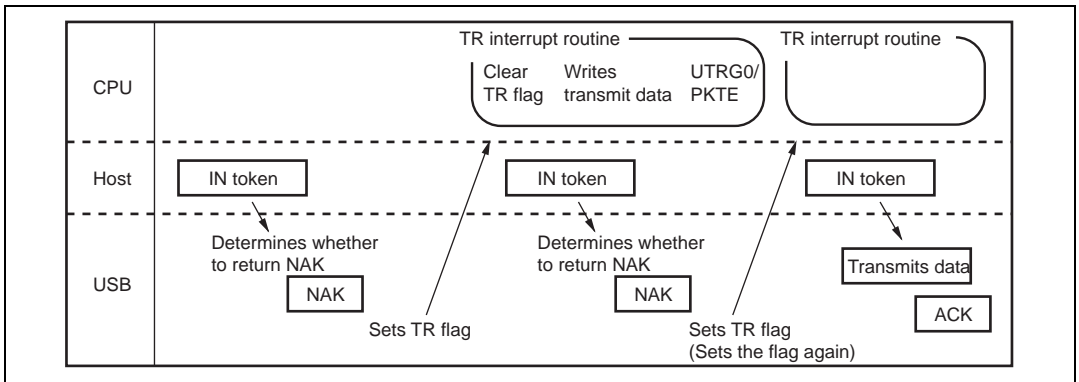
$DrVCC = VCC$ ,  $DrVSS = 0\text{ V}$ ,  $USD+ = USD- = USPND = \text{open state}$ ,  $VBUS = \overline{UBPM} = 0\text{ V}$

### 14.8.15 Notes on TR Interrupt

Note the following when using the transfer request interrupt (TR interrupt) for IN transfer to EP0i, EP1, or EP3.

The TR interrupt flag is set if the FIFO for the target EP has no data when the IN token is sent from the USB host. However, at the timing shown in figure 14.30, multiple TR interrupts occur successively. Take appropriate measures against malfunction in such a case.

Note: This module determines whether to return NAK if the FIFO of the target EP has no data when receiving the IN token, but the TR interrupt flag is set only after a NAK handshake is sent. If the next IN token is sent before PKTE of UTRG0 is written to, the TR interrupt flag is set again.



**Figure 14.30 TR Interrupt Flag Set Timing**

### 14.8.16 Clearing the FIFO when DMA Transfer Is Enabled

When DMA transfer is enabled ( $EP2T1 = 1$  and  $EP2T0 = 0$  or  $1$  in UDMAR) at endpoint 2, it is not possible to clear OUTFIFO in EP2. It is necessary to disable DMA transfer ( $EP2T1 = 0$  and  $EP2T0 = 0$  in UDMAR) before clearing the FIFO.

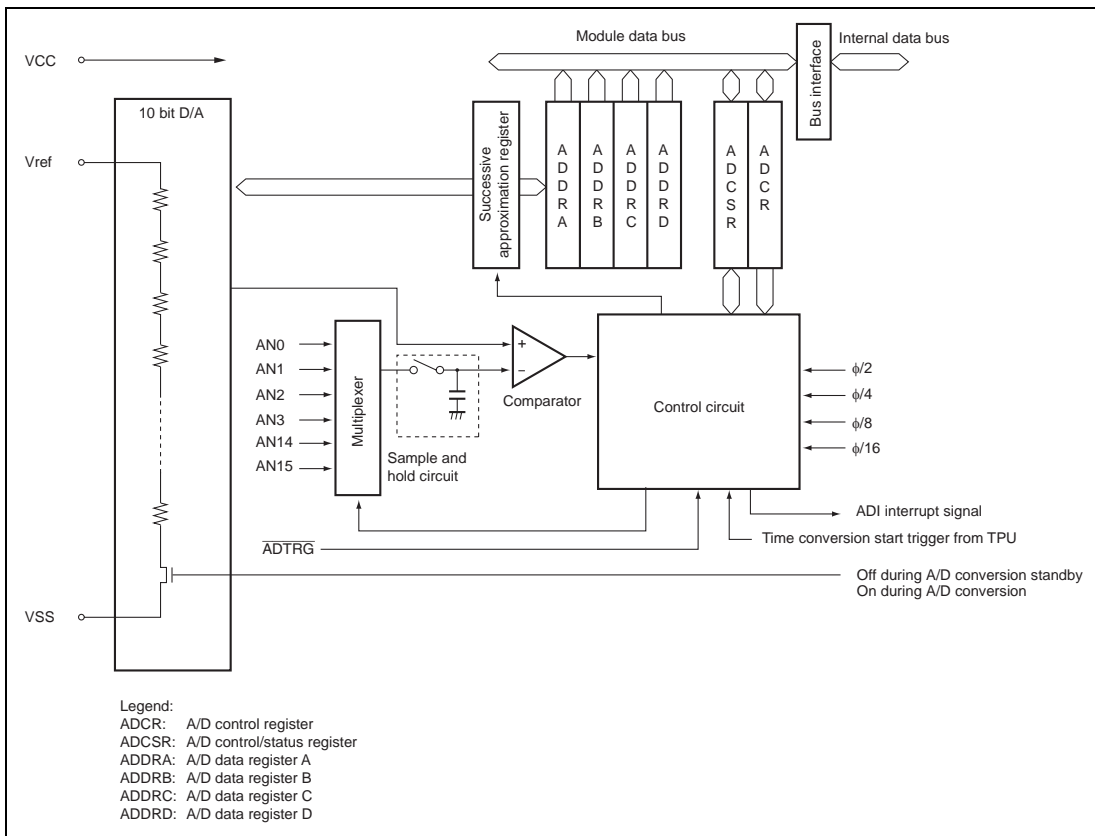


## Section 15 A/D Converter

This LSI includes a successive approximation type 10-bit A/D converter that allows up to six analog input channels to be selected. The block diagram of the A/D converter is shown in figure 15.1.

### 15.1 Features

- 10-bit resolution
- Six input channels
- Conversion time: 8.1  $\mu$ s per channel (at 16-MHz operation), 10.7  $\mu$ s per channel (at 24-MHz operation), 21.8  $\mu$ s per channel (at 6-MHz operation)
- Two operating modes
  - Single mode: Single-channel A/D conversion
  - Scan mode: Continuous A/D conversion on 1 to 4 channels
- Four data registers
  - Conversion results are held in a 16-bit data register for each channel
- Sample and hold function
- Three methods conversion start
  - Software
  - Timer (TPU) conversion start trigger
  - External trigger signal ( $\overline{\text{ADTRG}}$ )
- Interrupt request
  - An A/D conversion end interrupt request (ADI) can be generated
- Module stop mode can be set
- Settable analog conversion voltage range
  - Analog conversion voltage range settable using the reference voltage pin ( $V_{\text{ref}}$ ) as the reference voltage



**Figure 15.1 Block Diagram of A/D Converter**



## 15.2 Input/Output Pins

Table 15.1 summarizes the input pins used by the A/D converter. The AN0 to AN3 and AN14 to AN15 pins are analog input pins. The VCC and VSS pins are the power supply pins for the analog block in the A/D converter. The Vref pin is the reference voltage pin for the A/D conversion.

**Table 15.1 Pin Configuration**

Pin Name	Symbol	I/O	Function
Power supply pin	VCC	Input	Analog block power supply and reference voltage (also used for digital block)
Ground pin	VSS	Input	Analog block ground and reference voltage (also used for digital block)
Reference voltage pin	Vref	Input	Reference voltage pin for A/D conversion
Analog input pin 0	AN0	Input	Analog input pins
Analog input pin 1	AN1	Input	
Analog input pin 2	AN2	Input	
Analog input pin 3	AN3	Input	
Analog input pin 14	AN14	Input	
Analog input pin 15	AN15	Input	
A/D external trigger input pin	$\overline{\text{ADTRG}}$	Input	External trigger input pin for starting A/D conversion

## 15.3 Register Descriptions

The A/D converter has the following registers.

- A/D data register A (ADDRA)
- A/D data register B (ADDRB)
- A/D data register C (ADDRC)
- A/D data register D (ADDRD)
- A/D control/status register (ADCSR)
- A/D control register (ADCR)

### 15.3.1 A/D Data Registers A to D (ADDRA to ADDR D)

There are four 16-bit read-only ADDR registers; ADDRA to ADDR D, used to store the results of A/D conversion. The ADDR registers, which store a conversion result for each channel, are shown in table 15.2.

The converted 10-bit data is stored in bits 6 to 15. The lower 6 bits are always read as 0.

The data bus between the CPU and the A/D converter is 8 bits wide. The upper byte can be read directly from the CPU, however the lower byte should be read via a temporary register. The temporary register contents are transferred from the ADDR when the upper byte data is read. When reading the ADDR, read the upper byte before the lower byte, or read in word unit. The initial value of the ADDR is H'0000.

**Table 15.2 Analog Input Channels and Corresponding ADDR Registers**

Analog Input Channel	A/D Data Register to Be Stored the Results of A/D Conversion
AN0	ADDRA
AN1	ADDRB
AN2, AN14	ADDRC
AN3, AN15	ADDRD

### 15.3.2 A/D Control/Status Register (ADCSR)

ADCSR controls A/D conversion operations.

Bit	Bit Name	Initial Value	R/W	Description
7	ADF	0	R/(W)*	<p>A/D End Flag</p> <p>A status flag that indicates the end of A/D conversion.</p> <p>[Setting conditions]</p> <ul style="list-style-type: none"> <li>When A/D conversion ends in single mode</li> <li>When A/D conversion ends on all channels specified in scan mode</li> </ul> <p>[Clearing conditions]</p> <ul style="list-style-type: none"> <li>When 0 is written after reading ADF = 1</li> <li>When DMAC is activated by an ADI interrupt and ADDR is read</li> </ul>

Bit	Bit Name	Initial Value	R/W	Description
6	ADIE	0	R/W	A/D Interrupt Enable A/D conversion end interrupt (ADI) request enabled when 1 is set.
5	ADST	0	R/W	A/D Start Clearing this bit to 0 stops A/D conversion, and the A/D converter enters the wait state. Setting this bit to 1 starts A/D conversion. It can be set to 1 by software, the timer conversion start trigger, and the A/D external trigger (ADTRG). In single mode, this bit is cleared to 0 automatically when conversion on the specified channel is complete. In scan mode, conversion continues sequentially on the specified channels until this bit is cleared to 0 by software, a reset, a transition to standby mode, or module stop mode.
4	SCAN	0	R/W	Scan Mode Selects single mode or scan mode as the A/D conversion operating mode. 0: Single mode 1: Scan mode
3	CH3	0	R/W	Channel Select 3 to 0
2	CH2	0	R/W	Select analog input channels.
1	CH1	0	R/W	When SCAN = 0
0	CH0	0	R/W	When SCAN = 1
				0000: AN0
				0001: AN1
				0010: AN2
				0011: AN3
				01xx: Setting prohibited
				10xx: Setting prohibited
				11xx: Setting prohibited
				1110: AN14
				1111: AN15
				Legend:
				x: Don't care

Note: \* The write value should always be 0 to clear this flag.

### 15.3.3 A/D Control Register (ADCR)

The ADCR enables A/D conversion started by an external trigger signal.

Bit	Bit Name	Initial Value	R/W	Description
7	TRGS1	0	R/W	Timer Trigger Select 1 and 0
6	TRGS0	0	R/W	Enables the start of A/D conversion by a trigger signal. Only set bits TRGS1 and TRGS0 while conversion is stopped (ADST = 0). 00: A/D conversion start by software 01: A/D conversion start by TPU 10: Setting prohibited 11: A/D conversion start by external trigger pin (ADTRG)
5, 4	—	All 1	—	Reserved These bits are always read as 1 cannot be modified.
3	CKS1	0	R/W	Clock Select 1 and 0
2	CKS0	0	R/W	These bits specify the A/D conversion time. The conversion time should be changed only when ADST = 0. 00: Conversion time = 530 states (Max.) 01: Conversion time = 266 states (Max.) 10: Conversion time = 134 states (Max.) 11: Conversion time = 68 states (Max.) The conversion time setting should exceed the conversion time shown in section 22.6, A/D Converter Characteristics.
1, 0	—	All 1	—	Reserved These bits are always read as 1, and only 1 should be written to them.

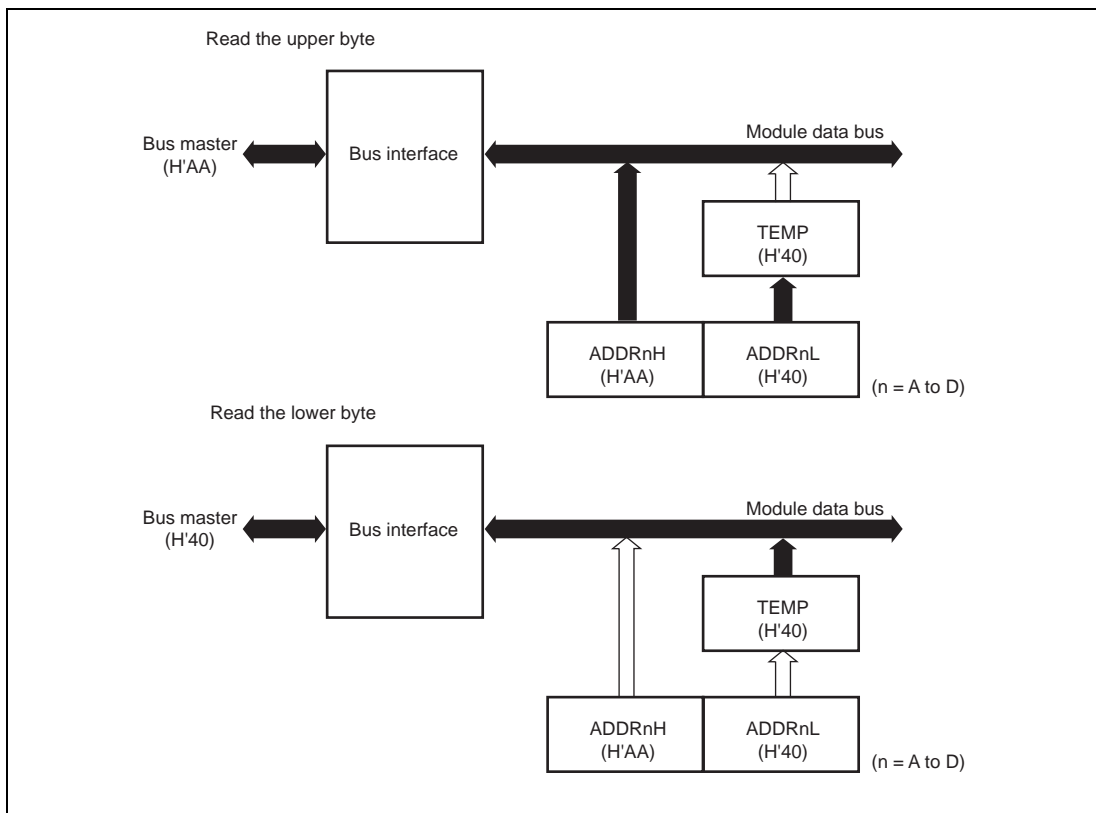
## 15.4 Interface to Bus Master

ADDRA to ADDR<sub>D</sub> are 16-bit registers. As the data bus to the bus master is 8 bits wide, the bus master accesses to the upper byte of the registers directly while to the lower byte of the registers via the temporary register (TEMP).

Data in ADDR is read in the following way: When the upper-byte data is read, the upper-byte data will be transferred to the CPU and the lower-byte data will be transferred to TEMP. Then, when the lower-byte data is read, the lower-byte data will be transferred to the CPU.

When data in ADDR is read, the data should be read from the upper byte and lower byte in the order. When only the upper-byte data is read, the data is guaranteed. However, when only the lower-byte data is read, the data is not guaranteed.

Figure 15.2 shows data flow when accessing to ADDR.



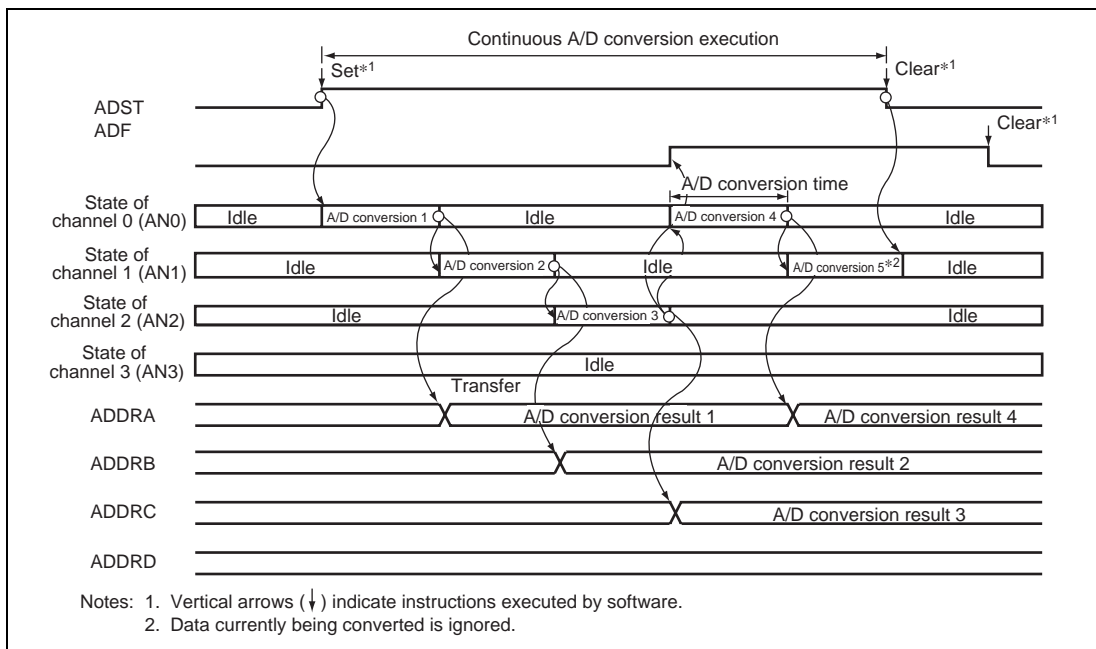
**Figure 15.2 Access to ADDR (When Reading H'AA40)**



## 15.5.2 Scan Mode

In scan mode, A/D conversion is to be performed sequentially on the specified channels (four channels maximum). The operations are as follows.

1. When the ADST bit is set to 1 by software, TPU or external trigger input, A/D conversion starts on the first channel in the group (AN0 when CH3 and CH2 = 00, AN4 when CH3 and CH2 = 01, or AN8 when CH3 and CH2 = 10).
2. When A/D conversion for each channel is completed, the result is sequentially transferred to the A/D data register corresponding to each channel.
3. When conversion of all the selected channels is completed, the ADF flag is set to 1. If the ADIE bit is set to 1 at this time, an ADI interrupt is requested after A/D conversion ends. Conversion of the first channel in the group starts again.
4. Steps 2 to 3 are repeated as long as the ADST bit remains set to 1. When the ADST bit is cleared to 0, A/D conversion stops.



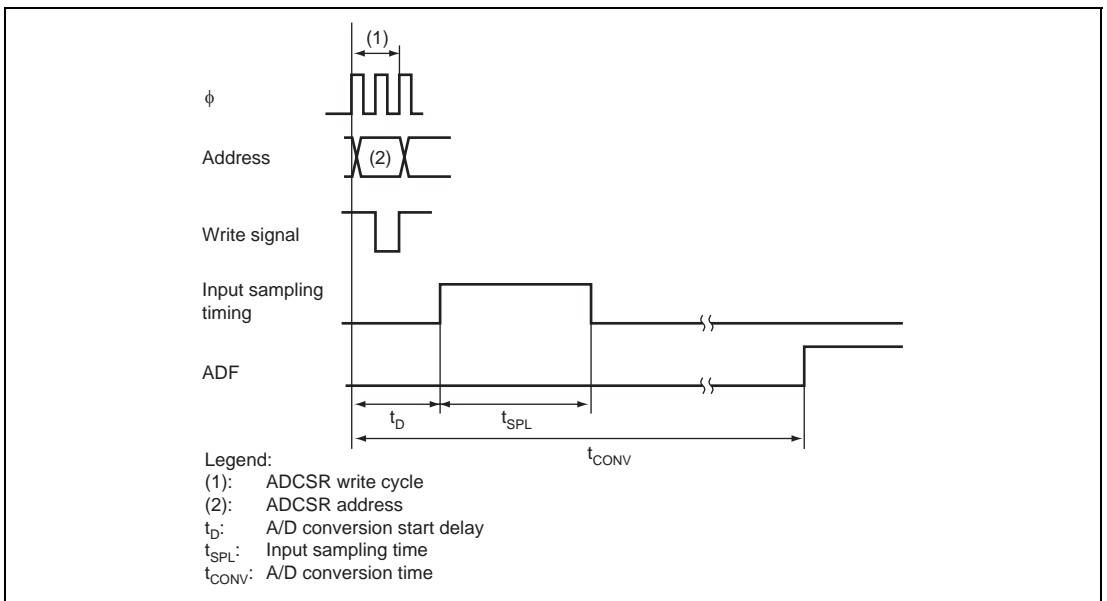
**Figure 15.4 A/D Conversion Timing (Scan Mode, Channels AN0 to AN2 Selected)**

### 15.5.3 Input Sampling and A/D Conversion Time

The A/D converter has a built-in sample-and-hold circuit. The A/D converter samples the analog input when the A/D conversion start delay time ( $t_D$ ) has passed after the ADST bit is set to 1, then starts conversion. Figure 15.5 shows the A/D conversion timing. Tables 15.3 and 15.4 show the A/D conversion time.

As indicated in figure 15.5, the A/D conversion time ( $t_{CONV}$ ) includes  $t_D$  and the input sampling time ( $t_{SPL}$ ). The length of  $t_D$  varies depending on the timing of the write access to ADCSR. The total conversion time therefore varies within the ranges indicated in table 15.4.

In scan mode, the values given in table 15.4 apply to the first conversion time. The values given in table 15.3 apply to the second and subsequent conversions.



**Figure 15.5 A/D Conversion Timing**



**Table 15.3 A/D Conversion Time (Single Mode)**

Item	Symbol	CKS1 = 0						CKS1 = 1					
		CKS0 = 0			CKS0 = 1			CKS0 = 0			CKS0 = 1		
		Min.	Typ.	Max.	Min.	Typ.	Max.	Min.	Typ.	Max.	Min.	Typ.	Max.
A/D conversion start delay	$t_D$	18	—	33	10	—	17	6	—	9	4	—	5
Input sampling time	$t_{SPL}$	—	127	—	—	63	—	—	31	—	—	15	—
A/D conversion time	$t_{CONV}$	515	—	530	259	—	266	131	—	134	67	—	68

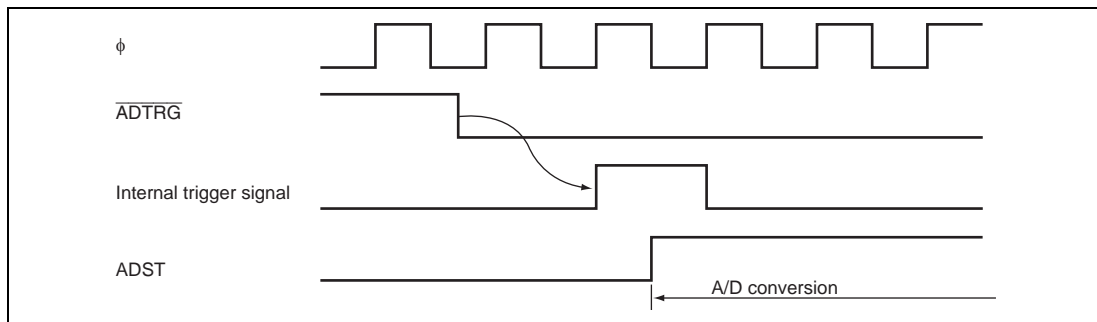
Note: All values represent the number of states.

**Table 15.4 A/D Conversion Time (Scan Mode)**

CKS1	CKS0	Conversion Time (State)
0	0	512 (Fixed)
	1	256 (Fixed)
1	0	128 (Fixed)
	1	64 (Fixed)

### 15.5.4 External Trigger Input Timing

A/D conversion can be externally triggered. When the TRGS0 and TRGS1 bits are set to 11 in ADCR, external trigger input is enabled at the  $\overline{\text{ADTRG}}$  pin. A falling edge at the  $\overline{\text{ADTRG}}$  pin sets the ADST bit to 1 in ADCSR, starting A/D conversion. Other operations, in both single and scan modes, are the same as when the bit ADST has been set to 1 by software. Figure 15.6 shows the timing.

**Figure 15.6 External Trigger Input Timing**

## 15.6 Interrupts

The A/D converter generates an A/D conversion end interrupt (ADI) at the end of A/D conversion. Setting the ADIE bit to 1 enables ADI interrupt requests while the bit ADF in ADCSR is set to 1 after A/D conversion is completed. The DMAC can be activated by an ADI interrupt.

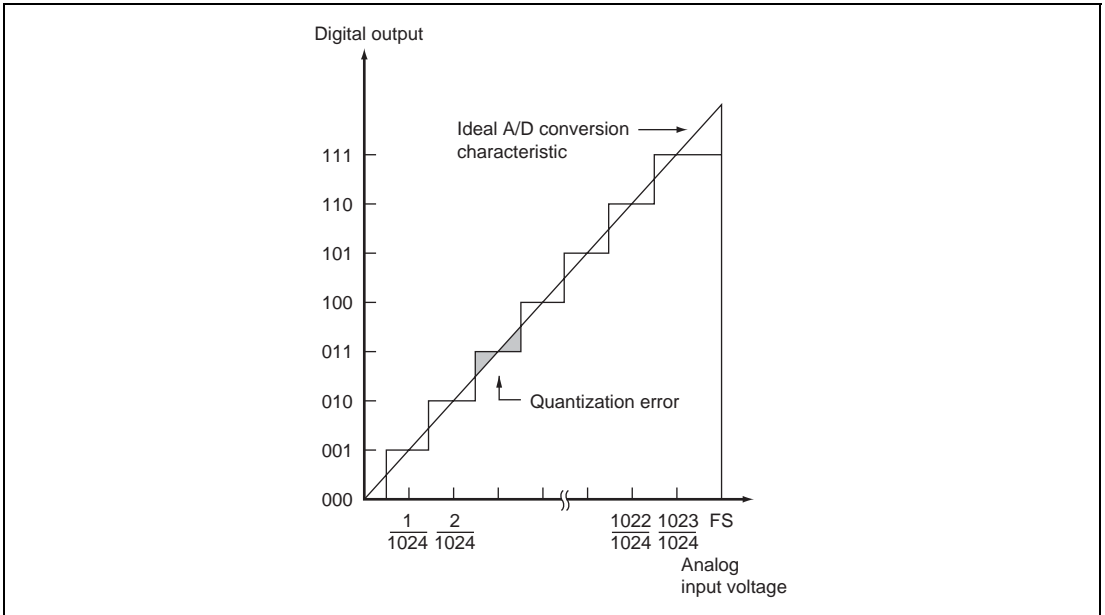
**Table 15.5 A/D Converter Interrupt Source**

Name	Interrupt Source	Interrupt Source Flag	DMAC Activation
ADI	A/D conversion completed	ADF	Possible

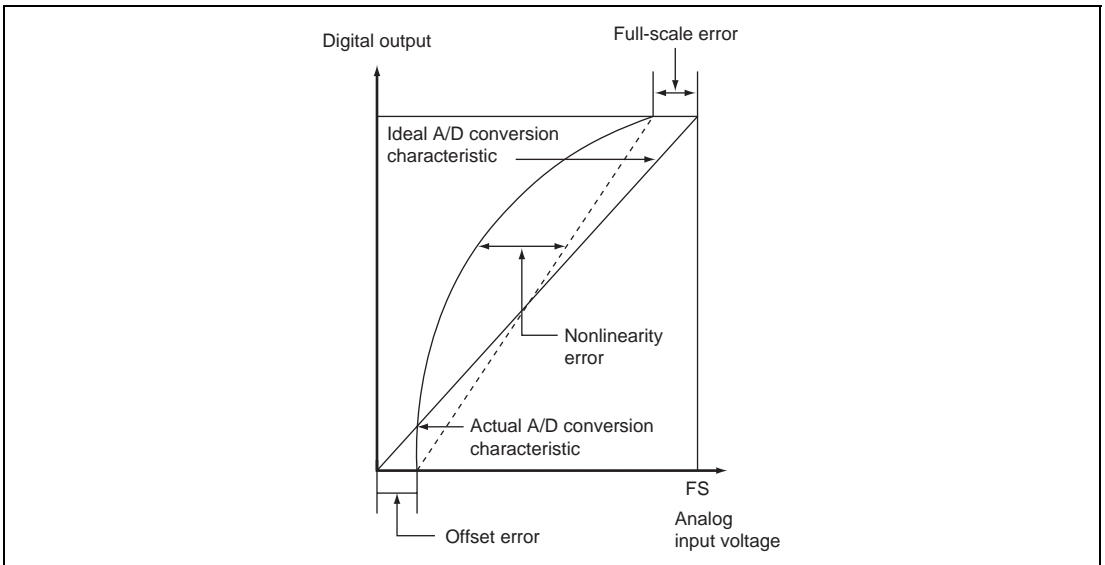
## 15.7 A/D Conversion Precision Definitions

This LSI's A/D conversion precision definitions are given below.

- Resolution  
The number of A/D converter digital output codes
- Quantization error  
The deviation inherent in the A/D converter, given by 1/2 LSB (see figure 15.7).
- Offset error  
The deviation of the analog input voltage value from the ideal A/D conversion characteristic when the digital output changes from the minimum voltage value B'000000000 (H'000) to B'000000001 (H'001) (see figure 15.8).
- Full-scale error  
The deviation of the analog input voltage value from the ideal A/D conversion characteristic when the digital output changes from B'111111110 (H'3FE) to B'111111111 (H'3FF) (see figure 15.8).
- Nonlinearity error  
The error with respect to the ideal A/D conversion characteristic between zero voltage and full-scale voltage. Does not include offset error, full-scale error, or quantization error (see figure 15.8).
- Absolute precision  
The deviation between the digital value and the analog input value. Includes offset error, full-scale error, quantization error, and nonlinearity error.



**Figure 15.7 A/D Conversion Precision Definitions (1)**



**Figure 15.8 A/D Conversion Precision Definitions (2)**

## 15.8 Usage Notes

### 15.8.1 Module Stop Mode Setting

Operation of the A/D converter can be disabled or enabled using the module stop control register. The initial setting is for operation of the A/D converter to be halted. Register access is enabled by clearing module stop mode. For details, refer to section 20, Power-Down Modes.

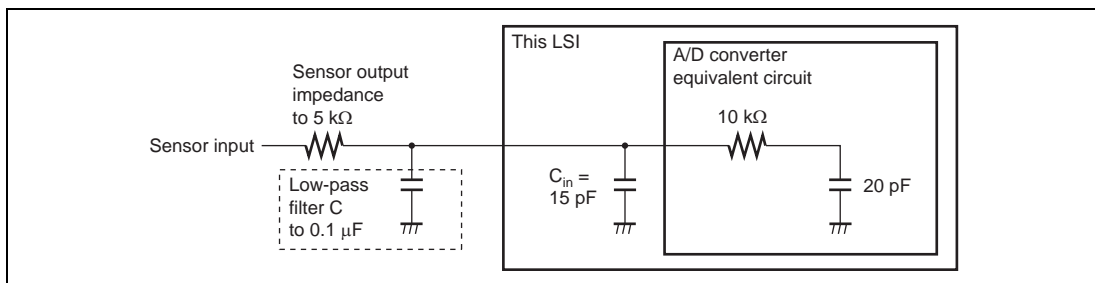
### 15.8.2 Permissible Signal Source Impedance

This LSI's analog input is designed such that conversion precision is guaranteed for an input signal for which the signal source impedance is  $5\text{ k}\Omega$  or less. This specification is provided to enable the A/D converter's sample-and-hold circuit input capacitance to be charged within the sampling time; if the sensor output impedance exceeds  $5\text{ k}\Omega$ , charging may be insufficient and it may not be possible to guarantee A/D conversion precision. However, for A/D conversion in single mode with a large capacitance provided externally, the input load will essentially comprise only the internal input resistance of  $10\text{ k}\Omega$ , and the signal source impedance is ignored. However, as a low-pass filter effect is obtained in this case, it may not be possible to follow an analog signal with a large differential coefficient (e.g.,  $5\text{ mV}/\Omega\text{s}$  or greater) (see figure 15.9). When converting a high-speed analog signal, a low-impedance buffer should be inserted.

### 15.8.3 Influences on Absolute Precision

Adding capacitance results in coupling with GND, and therefore noise in GND may adversely affect absolute precision. Be sure to make the connection to an electrically stable GND such as AVSS.

Care is also required to insure that filter circuits do not communicate with digital signals on the mounting board (i.e., acting as antennas).



**Figure 15.9 Example of Analog Input Circuit**

### 15.8.4 Range of Analog Power Supply and Other Pin Settings

If the conditions below are not met, the reliability of the device may be adversely affected.

- Analog input voltage range  
The voltage applied to analog input pin ANn during A/D conversion should be in the range  $V_{SS} \leq ANn \leq V_{ref}$ .
- Vref input range  
The analog reference voltage input at the Vref pin set is the range  $V_{ref} \leq V_{cc}$ .

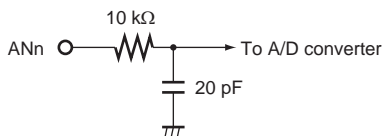
### 15.8.5 Notes on Board Design

Careful consideration is required in board design for noise countermeasures and in order to prevent damage due to abnormal voltage, such as an excessive surge at the analog input pins (AN0 to AN3 or AN14 to AN15) and analog reference voltage pin (Vref).

**Table 15.6 Analog Pin Specifications**

Item	Min.	Max.	Unit
Analog input capacitance	—	20	pF
Permissible signal source impedance	—	5*	k $\Omega$

Note: \*  $V_{cc} = 2.7$  to  $3.6$  V



Note: Values are reference values.

**Figure 15.10 Analog Input Pin Equivalent Circuit**



## Section 16 RAM

The HD64F2218, HD64F2218U, and HD64F2218CU have 12 kbytes of on-chip high-speed static RAM. The HD6432217, HD64F2211, HD64F2211U, and HD64F2211CU have 8 kbytes of on-chip high-speed static RAM. The HD6432210 and HD6432210S have 4 kbytes of on-chip high-speed static RAM. The RAM is connected to the CPU by a 16-bit data bus, enabling one-state access by the CPU to both byte data and word data.

The on-chip RAM can be enabled or disabled by means of the RAM enable bit (RAME) in the system control register (SYSCR). For details on SYSCR, refer to section 3.2.2, System Control Register (SYSCR).

Product Class	ROM Type	RAM Size	RAM Address	
H8S/2218 Group	HD64F2218	Flash memory Version	12 kbytes	H'FFC000 to H'FFEFBF
	HD64F2218U			H'FFFC0 to H'FFFFF
	HD64F2218CU			
	HD64F2217CU			
	HD6432217	Masked ROM Version	8 kbytes	H'FFD000 to H'FFEFBF H'FFFC0 to H'FFFFF
H8S/2212 Group	HDF64F2212	Flash memory Version	12 kbytes	H'FFC000 to H'FFEFBF
	HDF64F2212U			H'FFFC0 to H'FFFFF
	HDF64F2212CU			
	HD64F2211			8 kbytes
	HD64F2211U	H'FFFC0 to H'FFFFF		
	HD64F2211CU			
	HD64F2210CU			
	HD6432211	Masked ROM Version	8 kbytes	H'FFD000 to H'FFEFBF H'FFFC0 to H'FFFFF
	HD6432210		4 kbytes	H'FFE000 to H'FFEFBF
	HD6432210S			H'FFFC0 to H'FFFFF





## Section 17 Flash Memory (F-ZTAT Version)

The features of the on-chip flash memory are summarized below. The block diagram of the flash memory is shown in figure 17.1.

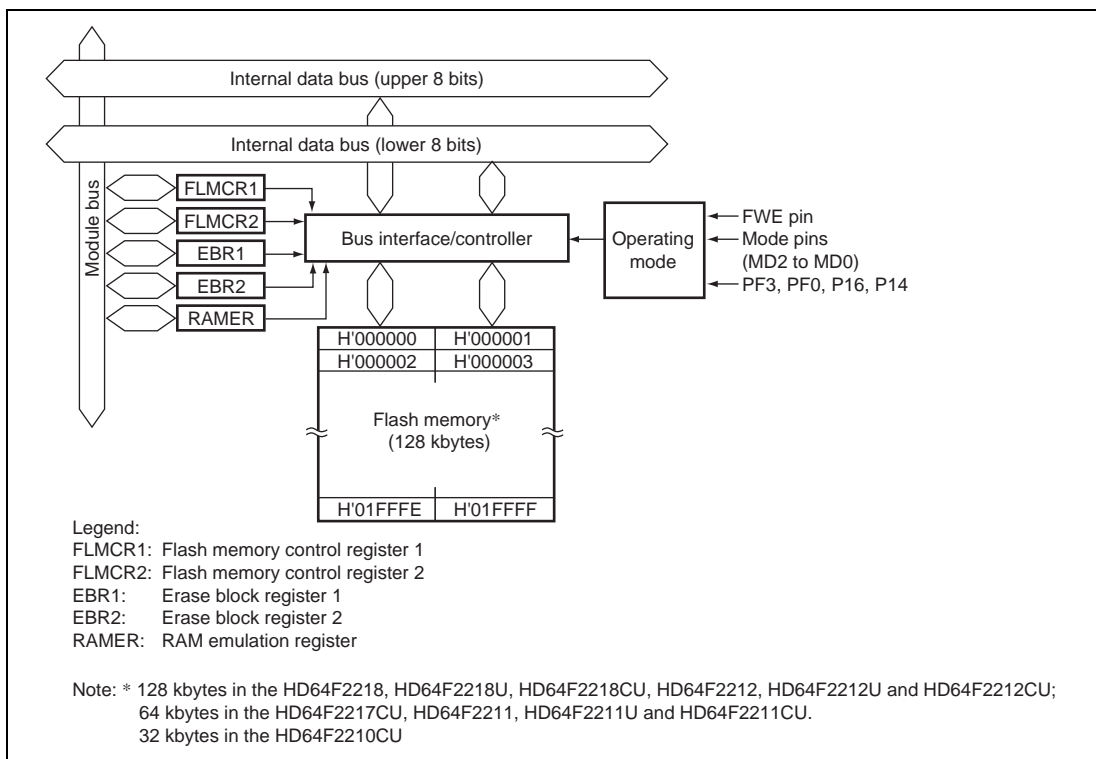
### 17.1 Features

- Size:

Product Class		ROM Size	ROM Address
H8S/2218 Group	HD64F2218, HD64F2218U HD64F2218CU	128 kbytes	H'000000 to H'01FFFF (Modes 6 and 7)
	HD64F2217CU	64 kbytes	H'000000 to H'00FFFF (Modes 6 and 7)
H8S/2212 Group	HD64F2212, HD64F2212U HD64F2212CU	128 kbytes	H'000000 to H'01FFFF (Mode 7)
	HD64F2211, HD64F2211U HD64F2211CU	64 kbytes	H'000000 to H'00FFFF (Mode 7)
	HD64F2210CU	32 kbytes	H'000000 to H'007FFF (Mode 7)

- Programming/erase methods
  - The flash memory is programmed 128 bytes at a time. Erase is performed in single-block units. The flash memory is configured as follows: 32 kbytes × 2 blocks, 28 kbytes × 1 block, 16 kbytes × 8 blocks, 8 kbytes × 1 block, and 1 kbyte × 4 blocks. To erase the entire flash memory, each block must be erased in turn.
- Reprogramming capability
  - Flash memory can be reprogrammed a minimum of 100 times.
- Two flash memory operating modes
  - Boot mode
    - SCI boot mode: HD64F2218, HD64F2212, and HD64F2211
    - USB boot mode: HD64F2218U, HD64F2218CU, HD64F2217CU, HD64F2212U, HD64F2212CU, HD64F2211U, HD64F2211CU and HD64F2210CU
  - User program mode
    - On-board programming/erasing can be done in boot mode in which the boot program built into the chip is started for erase or programming of the entire flash memory. In normal user program mode, individual blocks can be erased or programmed.

- Automatic bit rate adjustment
  - With data transfer in SCI boot mode, this LSI's bit rate can be automatically adjusted to match the transfer bit rate of the host.
- Programming/erasing protection
  - Sets hardware protection, software protection, and error protection against flash memory programming/erasing.
- Programmer mode
  - Flash memory can be programmed/erased in programmer mode, using a PROM programmer, as well as in on-board programming mode.
- Flash memory emulation in RAM
  - Flash memory programming can be emulated in real time by overlapping a part of RAM onto flash memory.

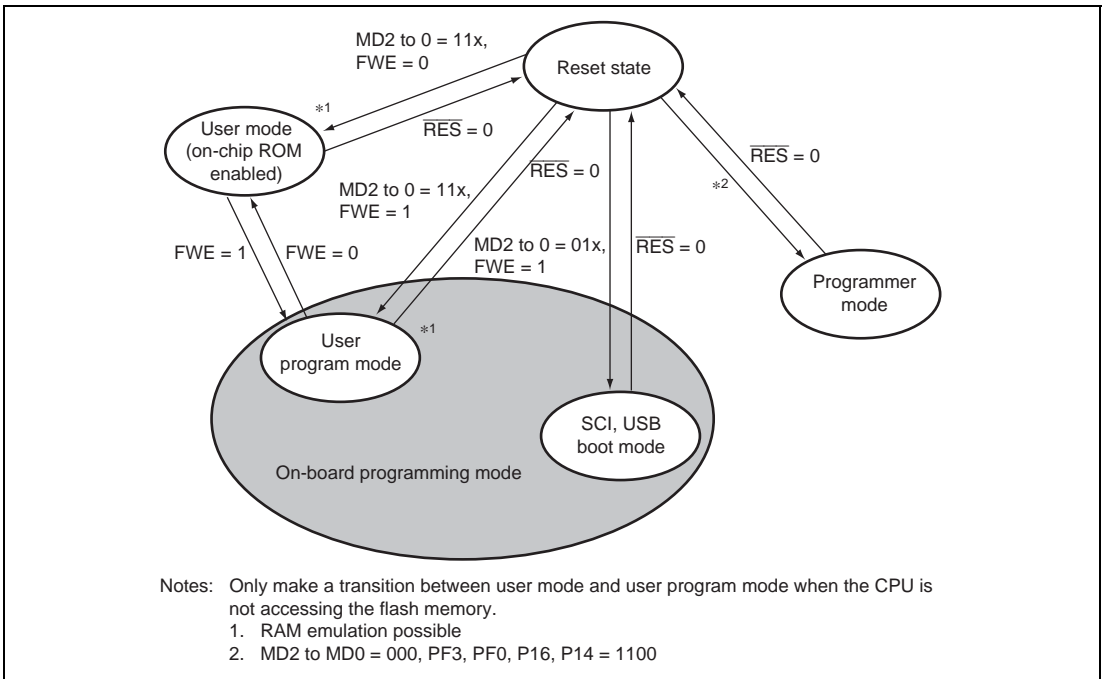


**Figure 17.1 Block Diagram of Flash Memory**

## 17.2 Mode Transitions

When the mode pins and the FWE pin are set in the reset state and a reset-start is executed, this LSI enters an operating mode as shown in figure 17.2. In user mode, flash memory can be read but not programmed or erased. The boot and user program modes are provided as modes to write and erase the flash memory.

The differences between boot mode and user program mode are shown in table 17.1. Boot mode and user program mode operations are shown in figures 17.3 and 17.4, respectively.



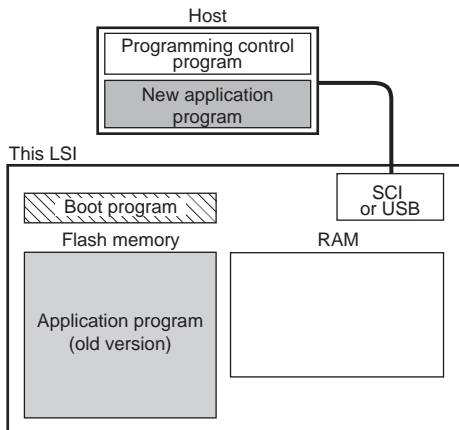
**Figure 17.2 Flash Memory State Transitions**

**Table 17.1 Differences between Boot Mode and User Program Mode**

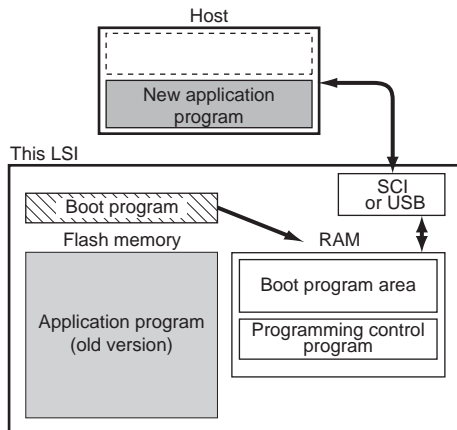
	SCI, USB Boot Mode	User Program Mode	User Mode
Total erase	Yes	Yes	No
Block erase	No	Yes	No
Programming control program*	Program/program-verify	Erase/erase-verify Program/program-verify Emulation	—

Note: \* To be provided by the user, in accordance with the recommended algorithm.

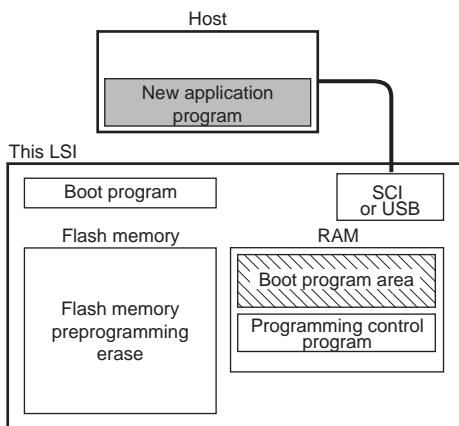
1. Initial state  
The old program version or data remains written in the flash memory. The user should prepare the programming control program and new application program beforehand in the host.



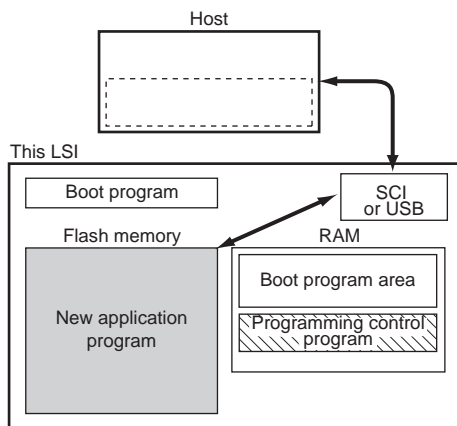
2. Programming control program transfer  
When boot mode is entered, the boot program in this LSI (originally incorporated in the chip) is started and the programming control program in the host is transferred to RAM via SCI or USB communication. The boot program required for flash memory erasing is automatically transferred to the RAM boot program area.



3. Flash memory initialization  
The erase program in the boot program area (in RAM) is executed, and the flash memory is initialized (to H'FF). In boot mode, total flash memory erasure is performed, without regard to blocks.



4. Writing new application program  
The programming control program transferred from the host to RAM is executed, and the new application program in the host is written into the flash memory.




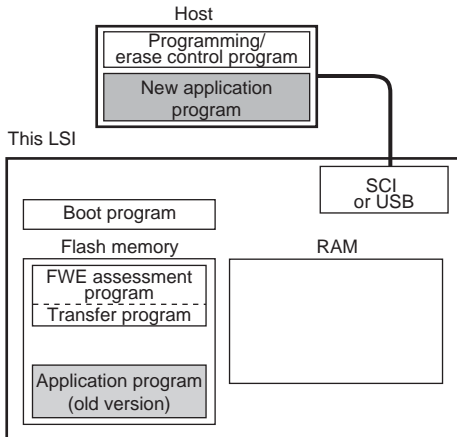
 Program execution state

Figure 17.3 Boot Mode (Sample)

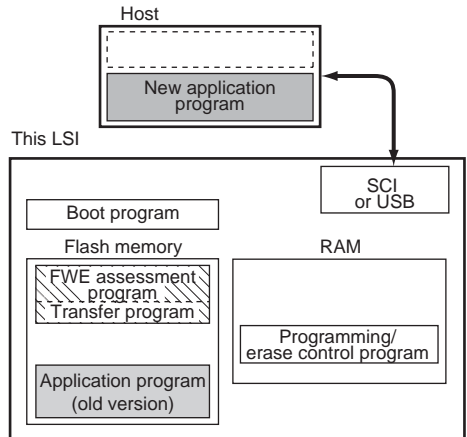
## 1. Initial state

The FWE assessment program that confirms that user program mode has been entered, and the program that will transfer the programming/erase control program from flash memory to on-chip RAM should be written into the flash memory by the user beforehand. The programming/erase control program should be prepared in the host or in the flash memory.



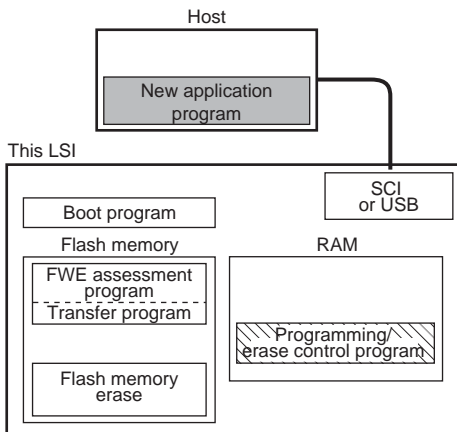
## 2. Programming/erase control program transfer

When user program mode is entered, user software confirms this fact, executes transfer program in the flash memory, and transfers the programming/erase control program to RAM.



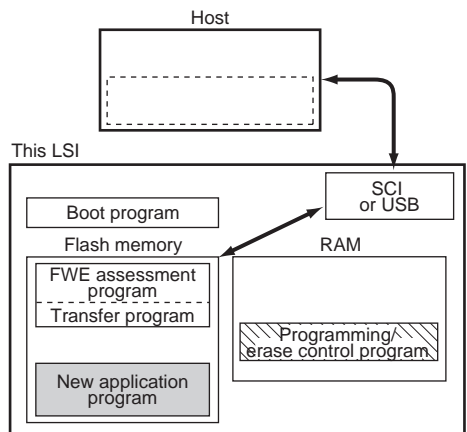
## 3. Flash memory initialization


The programming/erase program in RAM is executed, and the flash memory is initialized (to H'FF). Erasing can be performed in block units, but not in byte units.



## 4. Writing new application program

Next, the new application program in the host is written into the erased flash memory blocks. Do not write to unerased blocks.



 Program execution state

**Figure 17.4 User Program Mode (Sample)**

## 17.3 Block Configuration

Figure 17.5 shows the block configuration of 128-kbyte flash memory in the HD64F2218, HD64F2218U, HD64F2218CU, HD64F2212, HD64F2212U and HD64F2212CU. The thick lines indicate erasing units, the narrow lines indicate programming units, and the values are addresses. The flash memory is divided into one kbyte (four blocks), 28 kbytes (one block), 16 kbytes (one block), eight kbytes (two blocks), and 32 kbytes (two blocks). Erasing is performed in these divided units. Programming is performed in 128-byte units starting from an address whose lower eight bits are H'00 or H'80.

EB0 Erase unit 1 kbyte	H'000000	H'000001	H'000002	← Programming unit: 128 bytes →	H'00007F
	H'000380	H'000381	H'000382	-----	H'0003FF
EB1 Erase unit 1 kbyte	H'000400	H'000401	H'000402	← Programming unit: 128 bytes →	H'00047F
	H'000780	H'000781	H'000782	-----	H'0007FF
EB2 Erase unit 1 kbyte	H'000800	H'000801	H'000802	← Programming unit: 128 bytes →	H'00087F
	H'000B80	H'000B81	H'000B82	-----	H'000BFF
EB3 Erase unit 1 kbyte	H'000C00	H'000C01	H'000C02	← Programming unit: 128 bytes →	H'000C7F
	H'000F80	H'000F81	H'000F82	-----	H'000FFF
EB4 Erase unit 28 kbytes	H'001000	H'001001	H'001002	← Programming unit: 128 bytes →	H'00107F
	H'007F80	H'007F81	H'007F82	-----	H'007FFF
EB5 Erase unit 16 kbytes	H'008000	H'008001	H'008002	← Programming unit: 128 bytes →	H'00807F
	H'00BF80	H'00BF81	H'00BF82	-----	H'00BFFF
EB6 Erase unit 8 kbytes	H'00C000	H'00C001	H'00C002	← Programming unit: 128 bytes →	H'00C07F
	H'00DF80	H'00DF81	H'00DF82	-----	H'00DFFF
EB7 Erase unit 8 kbytes	H'00E000	H'00E001	H'00E002	← Programming unit: 128 bytes →	H'00E07F
	H'00FF80	H'00FF81	H'00FF82	-----	H'00FFFF
EB8 Erase unit 32 kbytes	H'010000	H'010001	H'010002	← Programming unit: 128 bytes →	H'01007F
	H'017F80	H'017F81	H'017F82	-----	H'017FFF
EB9 Erase unit 32 kbytes	H'018000	H'018001	H'018002	← Programming unit: 128 bytes →	H'01807F
	H'01FF80	H'01FF81	H'01FF82	-----	H'01FFFF

**Figure 17.5 Flash Memory Block Configuration**  
(HD64F2218, HD64F2218U, HD64F2218CU, HD64F2212, HD64F2212U, HD64F2212CU)

Figure 17.6 shows the block configuration of 64-kbyte flash memory in the HD64F2217CU, HD64F2211, HD64F2211U and HD64F2211CU. The thick lines indicate erasing units, the narrow lines indicate programming units, and the values are addresses. The flash memory is divided into one kbyte (four blocks), 28 kbytes (one block), and 16 kbytes (one block), eight kbytes (two blocks). Erasing is performed in these divided units. Programming is performed in 128-byte units starting from an address whose lower eight bits are H'00 or H'80.

EB0 Erase unit 1 kbyte	H'000000	H'000001	H'000002	← Programming unit: 128 bytes →	H'00007F
	H'000380	H'000381	H'000382	-----	H'0003FF
EB1 Erase unit 1 kbyte	H'000400	H'000401	H'000402	← Programming unit: 128 bytes →	H'00047F
	H'000780	H'000781	H'000782	-----	H'0007FF
EB2 Erase unit 1 kbyte	H'000800	H'000801	H'000802	← Programming unit: 128 bytes →	H'00087F
	H'000B80	H'000B81	H'000B82	-----	H'000BFF
EB3 Erase unit 1 kbyte	H'000C00	H'000C01	H'000C02	← Programming unit: 128 bytes →	H'000C7F
	H'000F80	H'000F81	H'000F82	-----	H'000FFF
EB4 Erase unit 28 kbytes	H'001000	H'001001	H'001002	← Programming unit: 128 bytes →	H'00107F
	H'007F80	H'007F81	H'007F82	-----	H'007FFF
EB5 Erase unit 16 kbytes	H'008000	H'008001	H'008002	← Programming unit: 128 bytes →	H'00807F
	H'00BF80	H'00BF81	H'00BF82	-----	H'00BFFF
EB6 Erase unit 8 kbytes	H'00C000	H'00C001	H'00C002	← Programming unit: 128 bytes →	H'00C07F
	H'00DF80	H'00DF81	H'00DF82	-----	H'00DFFF
EB7 Erase unit 8 kbytes	H'00E000	H'00E001	H'00E002	← Programming unit: 128 bytes →	H'00E07F
	H'00FF80	H'00FF81	H'00FF82	-----	H'00FFFF

**Figure 17.6 Flash Memory Block Configuration  
(HD64F2217CU, HD64F2211, HD64F2211U, HD64F2211CU)**

Figure 17.7 shows the block configuration of the 32 Kbyte flash memory in the HD64F2210CU. The thick lines indicate erase blocks, the narrow lines indicate programming units, and the values in the boxes are addresses. The flash memory is divided into units one Kbyte (four blocks) or 28 Kbytes (one block) in size, and erasing is performed in these units. Programming is performed in 128-byte units starting from an address whose lower eight bits are H'00 or H'80.

EB0 Erase unit 1 kbyte	H'000000	H'000001	H'000002	← Programming unit: 128 bytes →	H'00007F
	H'000380	H'000381	H'000382	-----	H'0003FF
EB1 Erase unit 1 kbyte	H'000400	H'000401	H'000402	← Programming unit: 128 bytes →	H'00047F
	H'000780	H'000781	H'000782	-----	H'0007FF
EB2 Erase unit 1 kbyte	H'000800	H'000801	H'000802	← Programming unit: 128 bytes →	H'00087F
	H'000B80	H'000B81	H'000B82	-----	H'000BFF
EB3 Erase unit 1 kbyte	H'000C00	H'000C01	H'000C02	← Programming unit: 128 bytes →	H'000C7F
	H'000F80	H'000F81	H'000F82	-----	H'000FFF
EB4 Erase unit 28 kbytes	H'001000	H'001001	H'001002	← Programming unit: 128 bytes →	H'00107F
	H'007F80	H'007F81	H'007F82	-----	H'007FFF

**Figure 17.7 Flash Memory Block Configuration  
(HD64F2210CU)**



## 17.4 Input/Output Pins

The flash memory is controlled by means of the pins shown in table 17.2.

**Table 17.2 Pin Configuration**

Pin Name	I/O	Function	
$\overline{\text{RES}}$	Input	Reset	All
FWE	Input	Flash program/erase protection by hardware	
MD2, MD1, MD0	Input	Sets this LSI's operating mode	
PF3, PF0, P16, P14	Input	Sets this LSI's operating mode in programmer mode	
EMLE	Input	Emulator enable	
TxD2	Output	Serial transmit data output	HD64F2218, HD64F2212, HD64F2211
RxD2	Input	Serial receive data input	
USD+, USD-	Input/output	USB data input/output	HD64F2218U, HD64F2218CU, HD64F2217CU,
VBUS	Input	USB cable connect/cut detect	HD64F2212U, HD64F2212CU, HD64F2211U
UBPM	Input	USB bus power mode/self power mode select	
USPND	Output	USB suspend output	
P36 (PUPD+)	Output	D+ pull-up control	

## 17.5 Register Descriptions

The flash memory has the following registers. For details on register addresses and register states during each processing, refer to section 21, List of Registers.

- Flash memory control register 1 (FLMCR1)
- Flash memory control register 2 (FLMCR2)
- Erase block register 1 (EBR1)
- Erase block register 2 (EBR2)
- RAM emulation register (RAMER)
- Serial control register X (SCRX)

The masked ROM version is not equipped with the above registers. Attempting to read them will produce an undetermined value, and writing to them is invalid.

### 17.5.1 Flash Memory Control Register 1 (FLMCR1)

FLMCR1 is a register that makes the flash memory transit to program mode, program-verify mode, erase mode, or erase-verify mode. For details on register setting, refer to section 17.8, Flash Memory Programming/Erasing.

Bit	Bit Name	Initial Value	R/W	Description
7	FWE	—*	R	Flash Write Enable Reflects the input level at the FWE pin. It is set to 1 when a low level is input to the FWE pin, and cleared to 0 when a high level is input.
6	SWE1	0	R/W	Software Write Enable When this bit is set to 1, flash memory programming/erasing is enabled. When this bit is cleared to 0, other FLMCR1 register bits and all EBR1, EBR2 bits cannot be set. [Setting condition] When FWE = 1
5	ESU1	0	R/W	Erase Setup When this bit is set to 1, the flash memory transits to the erase setup state. When it is cleared to 0, the erase setup state is cancelled. Set this bit to 1 before setting the E1 bit in FLMCR1. [Setting condition] When FWE = 1 and SWE1 = 1
4	PSU1	0	R/W	Program Setup When this bit is set to 1, the flash memory transits to the program setup state. When it is cleared to 0, the program setup state is cancelled. Set this bit to 1 before setting the P1 bit in FLMCR1. [Setting condition] When FWE = 1 and SWE1 = 1
3	EV1	0	R/W	Erase-Verify When this bit is set to 1, the flash memory transits to erase-verify mode. When it is cleared to 0, erase-verify mode is cancelled. [Setting condition] When FWE = 1 and SWE1 = 1

Bit	Bit Name	Initial Value	R/W	Description
2	PV1	0	R/W	<p>Program-Verify</p> <p>When this bit is set to 1, the flash memory transits to program-verify mode. When it is cleared to 0, program-verify mode is cancelled.</p> <p>[Setting condition]</p> <p>When FWE = 1 and SWE1 = 1</p>
1	E1	0	R/W	<p>Erase</p> <p>When this bit is set to 1 while the SWE1 and ESU1 bits are 1, the flash memory transits to erase mode. When it is cleared to 0, erase mode is cancelled.</p> <p>[Setting condition]</p> <p>When FWE = 1, SWE1 = 1, and ESU1 = 1</p>
0	P1	0	R/W	<p>Program</p> <p>When this bit is set to 1 while the SWE1 and PSU1 bits are 1, the flash memory transits to program mode. When it is cleared to 0, program mode is cancelled.</p> <p>[Setting condition]</p> <p>When FWE = 1, SWE1 = 1, and PSU1 = 1</p>

Note: \* Set according to the FWE pin state.

### 17.5.2 Flash Memory Control Register 2 (FLMCR2)

FLMCR2 is a register that displays the state of flash memory programming/erasing. FLMCR2 is a read-only register, and should not be written to.

Bit	Bit Name	Initial Value	R/W	Description
7	FLER	0	R	<p>Indicates that an error has occurred during an operation on flash memory (programming or erasing). When FLER is set to 1, flash memory goes to the error-protection state.</p> <p>See section 17.9.3, Error Protection, for details.</p>
6 to 0	—	All 0	—	<p>Reserved</p> <p>These bits are always read as 0.</p>

### 17.5.3 Erase Block Register 1 (EBR1)

EBR1 specifies the flash memory erase area block. EBR1 is initialized to H'00 when the SWE1 bit in FLMCR is 0. Do not set more than one bit at a time, as this will cause all the bits in EBR1 and EBR2 to be automatically cleared to 0.

Bit	Bit Name	Initial Value	R/W	Description
7	EB7	0	R/W	When this bit is set to 1, 8 kbytes of EB7 (H'00E000 to H'00FFFF) are to be erased.
6	EB6	0	R/W	When this bit is set to 1, 8 kbytes of EB6 (H'00C000 to H'00DFFF) are to be erased.
5	EB5	0	R/W	When this bit is set to 1, 16 kbytes of EB5 (H'008000 to H'00BFFF) are to be erased.
4	EB4	0	R/W	When this bit is set to 1, 28 kbytes of EB4 (H'001000 to H'007FFF) are to be erased.
3	EB3	0	R/W	When this bit is set to 1, 1 kbyte of EB3 (H'000C00 to H'000FFF) is to be erased.
2	EB2	0	R/W	When this bit is set to 1, 1 kbyte of EB2 (H'000800 to H'000BFF) is to be erased.
1	EB1	0	R/W	When this bit is set to 1, 1 kbyte of EB1 (H'000400 to H'0007FF) is to be erased.
0	EB0	0	R/W	When this bit is set to 4, 1 kbyte of EB0 (H'000000 to H'0003FF) is to be erased.

### 17.5.4 Erase Block Register 2 (EBR2)

EBR2 specifies the flash memory erase area block. EBR2 is initialized to H'00 when the SWE1 bit in FLMCR1 is 0. Do not set more than one bit at a time, as this will cause all the bits in EBR1 and EBR2 to be automatically cleared to 0.

Note: These registers are reserved on the HD64F2211 and HD64F2211U. Only H'00 should be written to them.

Bit	Bit Name	Initial Value	R/W	Description
7 to 2	—	All 0	R/W	Reserved The write value should always be 0.
1	EB9	0	R/W	When this bit is set to 1, 32 kbytes of EB9 (H'018000 to H'01FFFF) are to be erased.
0	EB8	0	R/W	When this bit is set to 1, 32 kbytes of EB8 (H'010000 to H'017FFF) are to be erased.

### 17.5.5 RAM Emulation Register (RAMER)

RAMER specifies the area of flash memory to be overlapped with part of RAM when emulating real-time flash memory programming. RAMER settings should be made in user mode or user program mode. To ensure correct operation of the emulation function, the ROM for which RAM emulation is performed should not be accessed immediately after this register has been modified. Normal execution of an access immediately after register modification is not guaranteed. For details, refer to section 17.7, Flash Memory Emulation in RAM.

Bit	Bit Name	Initial Value	R/W	Description
7 to 4	—	All 0	R/W	Reserved These bits always read as 0. The write value should always be 0.
3	RAMS	0	R/W	RAM Select Specifies selection or non-selection of flash memory emulation in RAM. When RAMS = 1, the flash memory is overlapped with part of RAM, and all flash memory block are program/erase-protected.
2	RAM2	0	R/W	Flash Memory Area Selection
1	RAM1	0	R/W	When the RAMS bit is set to 1, selects one of the following flash memory areas to overlap the RAM area. The areas correspond with 1-kbyte erase blocks. 000: H'000000 to H'0003FF (EB0) 001: H'000400 to H'0007FF (EB1) 010: H'000800 to H'000BFF (EB2) 011: H'000C00 to H'000FFF (EB3) 100: Setting prohibited 101: Setting prohibited 110: Setting prohibited 111: Setting prohibited
0	RAM0	0	R/W	

### 17.5.6 Serial Control Register X (SCRX)

SCRX performs register access control.

Bit	Bit Name	Initial Value	R/W	Description
7 to 4	—	All 0	R/W	Reserved The write value should always be 0.
3	FLSHE	0	R/W	Flash Memory Control Register Enable: Controls CPU access to the flash memory control registers (FLMCR1, FLMCR2, EBR1, and EBR2). Setting the FLSHE bit to 1 enables read/write access to the flash memory control registers. If FLSHE is cleared to 0, the flash memory control registers are deselected. In this case, the flash memory control register contents are retained. 0: Flash control registers deselected in area H'FFFA8 to H'FFFFAC 1: Flash control registers selected in area H'FFFA8 to H'FFFFAC
2 to 0	—	All 0	R/W	Reserved The write value should always be 0.

## 17.6 On-Board Programming Modes

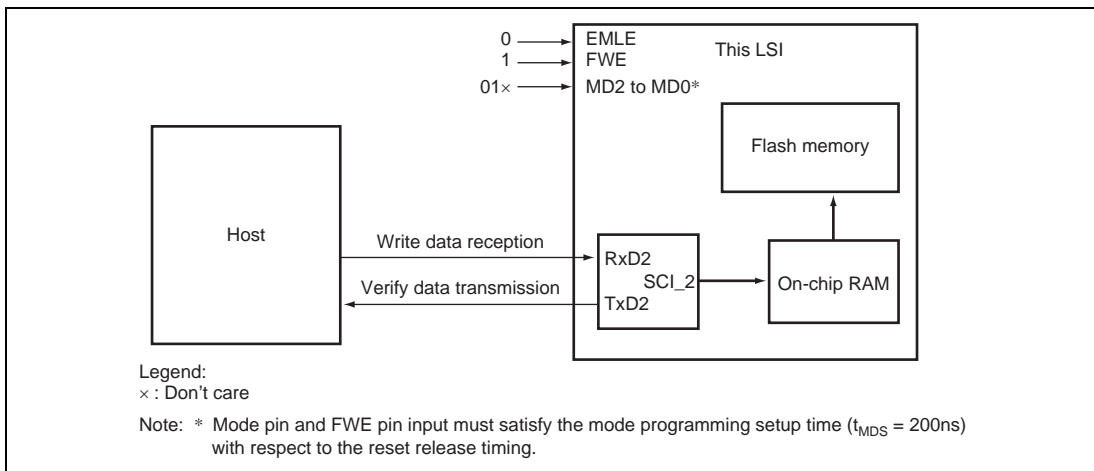
When pins are set to on-board programming mode and a reset-start is executed, a transition is made to the on-board programming state in which program/erase/verify operations can be performed on the on-chip flash memory. There are two on-board programming modes: boot mode and user program mode. The pin settings for transition to each of these modes are shown in table 17.3. For a diagram of the transitions to the various flash memory modes, see figure 17.2.

**Table 17.3 Setting On-Board Programming Modes**

Mode		EMLE	FWE	MD2	MD1	MD0
SCI boot mode (HD64F2218, HD64F2212, HD64F2211)	Advanced: single-chip mode	0	1	0	1	×
USB boot mode (HD64F2218U, HD64F2218CU, HD64F2217CU, HD64F2212U, HD64F2212CU, HD64F2211U, HD64F2211CU, HD64F2210CU)	Advanced: single-chip mode 24 MHz system clock	0	1	0	1	0
	Advanced: single-chip mode 16 MHz system clock	0	1	0	1	1
User program mode	Advanced: on-chip ROM extended mode (MCU operating mode 6)	0	1	1	1	0
	Advanced: Single-chip mode (MCU operating mode 7)	0	1	1	1	1

### 17.6.1 SCI Boot Mode (HD64F2218, HD64F2212, and HD64F2211)

When a reset-start is executed after the LSI's pins have been set to boot mode, the boot program built into the LSI is started and the programming control program prepared in the host is serially transmitted to the LSI via the SCI. In the LSI, the programming control program received via the SCI is written into the programming control program area in on-chip RAM. After the transfer is completed, control branches to the start address of the programming control program area and the programming control program execution state is entered (flash memory programming is performed). The system configuration in boot mode is shown in Figure 17.8.



**Figure 17.8 System Configuration in SCI Boot Mode**

Table 17.4 shows the boot mode operations between reset end and branching to the programming control program.

1. When boot mode is used, the flash memory programming control program must be prepared in the host beforehand. Prepare a programming control program in accordance with the description in section 17.8, Flash Memory Programming/Erasing. In boot mode, if any data has been programmed into the flash memory (if all data is not 1), all flash memory blocks are erased. Boot mode is for use in enforced exit when user program mode is unavailable, such as the first time on-board programming is performed, or if the program activated in user program mode is accidentally erased.
2. The SCI\_2 should be set to asynchronous mode, and the transfer format as follows: 8-bit data, 1 stop bit, and no parity.
3. When the boot program is initiated, the chip measures the low-level period of asynchronous SCI communication data (H'00) transmitted continuously from the host. The chip then calculates the bit rate of transmission from the host, and adjusts the SCI\_2 bit rate to match that of the host. The reset should end with the RxD pin high. The RxD and TxD pins should be pulled up on the board if necessary. After the reset ends, it takes approximately 100 states before the chip is ready to measure the low-level period.
4. After matching the bit rates, the chip transmits one H'00 byte to the host to indicate the end of bit rate adjustment. The host should confirm that this adjustment end indication (H'00) has been received normally, and transmit one H'55 byte to the chip. If reception could not be performed normally, initiate boot mode again by a reset. Depending on the host's transfer bit rate and system clock frequency of this LSI, there will be a discrepancy between the bit rates of the host and the chip. To operate the SCI properly, set the host's transfer bit rate and system clock frequency of this LSI within the ranges listed in table 17.5.



5. In boot mode, a part of the on-chip RAM area (four kbytes) is used by the boot program. The area to which the programming control program is transferred from the host is 8 kbytes (H'FFC000 to H'FFDFFF) in the HD64F2218 and HD64F2212 and 4 kbytes (H'FFD000 to H'FFDFFF) in the HD64F2211. The boot program area cannot be used until the execution state in boot mode switches to the programming control program.
6. Before branching to the programming control program, the chip terminates transfer operations by the SCI\_2 (by clearing the RE and TE bits in SCR to 0), but the adjusted bit rate value remains set in BRR. Therefore, the programming control program can still use it for transfer of write data or verify data with the host. The TxD pin is high. The contents of the CPU general registers are undefined immediately after branching to the programming control program. These registers must be initialized at the beginning of the programming control program, since the stack pointer (SP), in particular, is used implicitly in subroutine calls, etc.
7. Boot mode can be cleared by a reset. End the reset\* after driving the reset pin low, waiting at least 20 states, and then setting the FWE pin and the mode (MD) pins. Boot mode is also cleared when a WDT overflow occurs.
8. Do not change the MD pin input levels in boot mode. If the mode pin input levels are changed (for example, from low to high) during a reset, the state of ports with multiplexed address functions and bus control output pins ( $\overline{AS}$ ,  $\overline{RD}$ ,  $\overline{WR}$ ) will change according to the change in the microcomputer's operating mode. Therefore, care must be taken to make pin settings to prevent these pins from becoming output signal pins during a reset, or to prevent collision with signals outside the microcomputer.
9. All interrupts are disabled during programming or erasing of the flash memory.

Note:\* Mode pin and FWE pin input must satisfy the mode programming setup time ( $t_{MDS} = 200$  ns) with respect to the reset release timing.

**Table 17.4 Boot Mode Operation**

<b>Item</b>	<b>Host Operation</b>	<b>LSI Operation</b>
		Branches to boot program at reset-start
Bit rate adjustment	Continuously transmits data H'00 at specified bit rate	Measures low-level period of receive data H'00 Calculates bit rate and sets it in BRR of SCI_2
	Transmits data H'55 when data H'00 is received error-free	Transmits data H'00 to host as adjustment end indication Transmits data H'AA to host when data H'55 is received
Transmits number of bytes (N) of programming control program	Transmits number of bytes (N) of programming control program to be transferred as 2-byte data (low-order byte following high-order byte)	Echobacks the 2-byte data received as verification data
Transmits 1-byte of programming control program (repeated for N times)	Transmits 1-byte of programming control program	Echobacks received data to host and also transfers it to RAM
Flash memory erase		Checks flash memory data, erases all flash memory blocks in case of written data existing, and transmits data H'AA to host. (If erase could not be done, transmits data H'FF to host and aborts operation)
Programming control program execution		Branches to programming control program transferred to on-chip RAM and starts execution

**Table 17.5 System Clock Frequencies for which Automatic Adjustment of LSI Bit Rate Is Possible**

<b>Host Bit Rate</b>	<b>System Clock Frequency Range of LSI</b>
19,200 bps	8 to 24 MHz
9,600 bps	6 to 24 MHz
4,800 bps	6 to 24 MHz

## 17.6.2 USB Boot Mode (HD64F2218U, HD64F2212U, and HD64F2211U)

- Features
  - Selection of bus-powered mode or self-powered mode
  - Supports the USB operating clock generation by 16 MHz system clock with PLL3 multiplication (FWE = 1, MD2 to MD0 = 011) or 24 MHz system clock with PLL2 multiplication (FWE = 1, MD2 to MD0 = 010)
  - D+ pull up control connection supported for P36 pin only
  - See table 17.6 for enumeration information

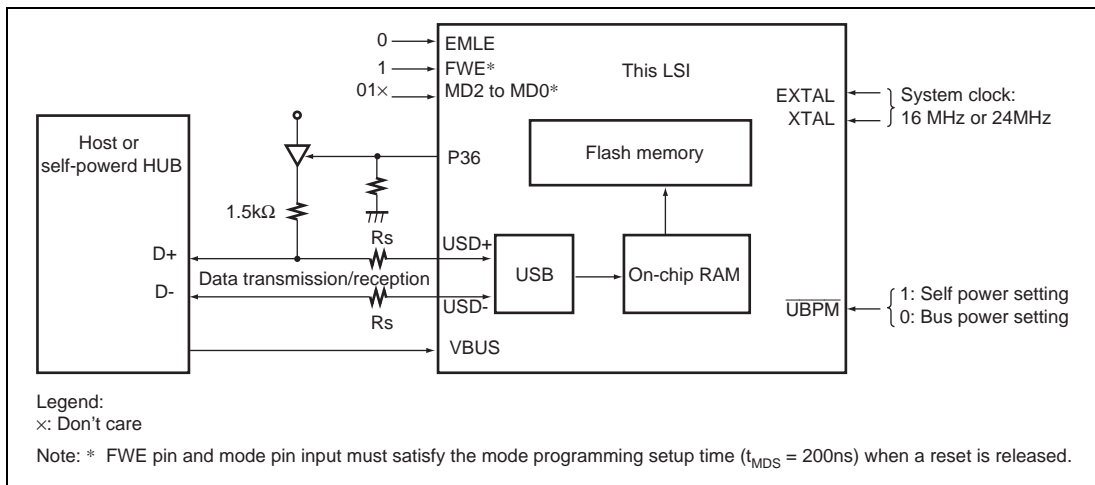
**Table 17.6 Enumeration Information**

USB Standard	Ver.1.1	
Transfer modes	Control (in, out), Bulk (in, out)	
Maximum power	Self power mode ( $\overline{\text{UBPM}}$ pin = 1)	100 mA
	Bus power mode ( $\overline{\text{UBPM}}$ pin = 0)	500 mA
Endpoint configuration	EP0 Control (in, out) 64 bytes	
	Configuration 1	
	└ Interface Number 0	
	└└ Alternate Setting 0	
	└└└ EP1 Bulk (in) 64 bytes	
	└└└ EP2 Bulk (out) 64 bytes	

- Notes on USB Boot Mode Execution
  - Specify 16 MHz or 24 MHz system clock and the FWE and MD2 to MD0 pins correctly.
  - Use the P36 pin for D+ pull-up control connection.
  - To ensure stable power supply during flash memory programming/erasing, do not use cable connection via a bus powered HUB.
  - Note in particular that, in the worst case, the LSI may be permanently damaged if the USB cable is detached during flash memory programming/erasing.
  - A transition is not made to power-down modes even if the USB bus enters suspend mode when in bus power mode.

- Overview

When a reset start preformed after the pins of this LSI have been set to boot mode, a boot program incorporated in the microcomputer beforehand is activated, and the prepared programming control program is transmitted sequentially to the host using the USB. With this LSI, the programming control program received by the USB is written to a programming control program area in on-chip RAM. After transfer is completed, control branches to the start address of the programming control program area, and the programming control program execution state is established (flash memory programming is performed). Figure 17.9 shows a system configuration diagram when using USB boot mode.



**Figure 17.9 System Configuration Diagram when Using USB Boot Mode**

Table 17.7 shows operations from reset release in USB boot mode until processing branches to the programming control program.

1. When boot mode is used, the flash memory programming control program must be prepared in the host beforehand. Prepare a programming control program in accordance with the description in section 17.8, Flash Memory Programming/Erasing. In boot mode, if any data has been programmed into the flash memory (if all data is not 1), all flash memory blocks are erased. Boot mode is for use in enforced exit when user program mode is unavailable, such as the first time on-board programming control program, or performed, or if the program activated in user program mode is accidentally erased.
2. When the boot program is activated, enumeration with respect to the host is carried out. Enumeration information is shown in table 17.6. When enumeration is completed, transmit a single H'55 byte from the host. If reception has not been preformed normally, restart boot mode by means of a reset.

3. Set the frequency for transmission from the host as a numeric value in units of MHz  $\times$  100 (ex: 16.00 MHz  $\rightarrow$  H'0640, 24.00 MHz  $\rightarrow$  H'0960).
4. In boot mode, the 4-kbyte on-chip RAM area H'FFE000 to H'FFEFBF is used by the boot program. The programming control program is transferred from the host stored in the 8-kbyte area H'FFC000 to H'FFDFFF in the HD64F2218U, HD64F2218CU, HD64F2212U, and HD64F2212CU and the 4-kbyte area H'FFD000 to H'FFDFFF in the HD64F2211U, HD64F2211CU and HD64F2210CU. The boot program area cannot be used until program execution switches to the programming control program. Also note that the boot program remains in RAM even after control passes to the programming control program.
5. When a branch is made to the programming control program, the USB remains connected and can be used immediately for transmission/reception of write data or verify data between the programming control program and the host. The contents of CPU general registers are undefined after a branch to the programming control program. Note, in particular, that since the stack pointer is used implicitly in subroutine calls and the like, it should be initialized at the start of the programming control program.
6. Boot mode is by means of a reset. Drive the reset pin low, wait for the elapse of at least 20 states, then set the FWE pin and mode pins to release the reset.\* Boot mode is also exited in the event of a WDT overflow reset.
7. Do not change the input level of the mode pins while in boot mode. In the input level of a mode pin is changed (from low to high) during a reset, the states of ports with a dual function as address output s, and bus control output signals ( $\overline{AS}$ ,  $\overline{RD}$ ,  $\overline{WR}$ ), will change due to switching of the operating mode. Either make pin settings so that these pins do not become output signal pins during a reset, or take precautions to prevent collisions with external signals.
8. Interrupt cannot be used during flash memory programming or erasing.

Note: \* FWE pin and mode pin input must satisfy the mode programming set up time ( $t_{MDS} = 200$  ns) when a reset is released.

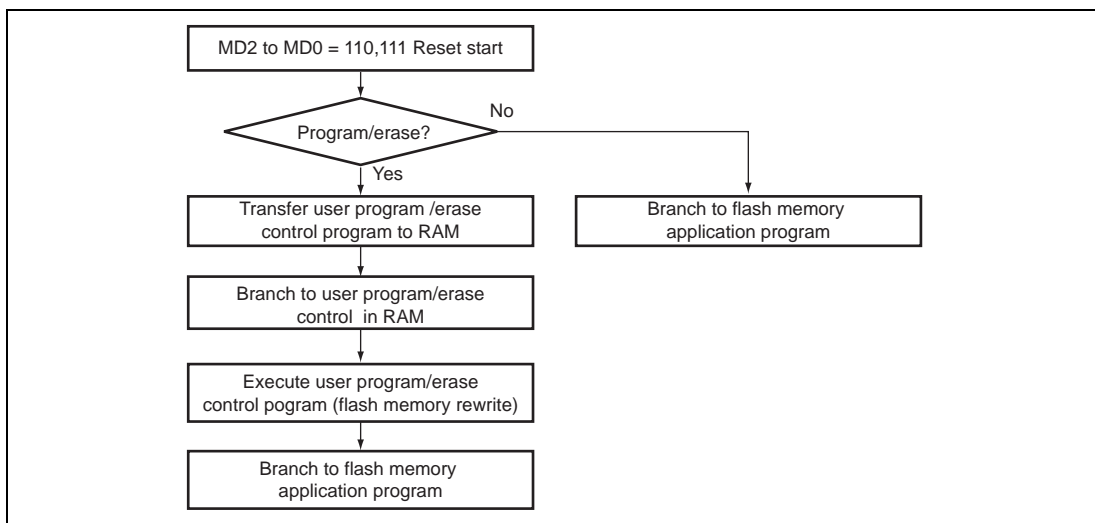
**Table 17.7 USB Boot Mode Operation**

Item	Host Operation	Operation of this LSI
Start of USB boot mode	Transmits one H'55 byte on completion of USB enumeration	Branches to boot program after reset start
Transfer clock information	Transmits frequency (2 bytes), number of multiplication Classification (1 byte), multiplication ratio (1 byte) With 16 MHz system clock, H'0640, H'01, H'01 are transmitted With 24 MHz system clock, H'0960, H'01, H'01 are transmitted	Transmits one H'AA byte to host on reception of H'55  If received data are within respective ranges, transmits H'AA to host If any received data is out-of-ranges, transmits H'FF to host and halts operation
Transfer number of bytes (N) of programming control program	Performs 2-byte transfer number of bytes (N) of programming control program	If received number of bytes is within ranges, transmits H'AA to host If received number of bytes is out-of- ranges, transmits H'FF to host and halts operation

Item	Host Operation	Operation of this LSI
Transfer of programming control program and sum value	<p data-bbox="394 118 726 172">Transmits programming control program in N-byte divisions.</p> <p data-bbox="394 284 707 400">Transmits sum value (two's complement of sum total of programming control program (1 byte))</p>	<p data-bbox="804 217 1126 271">Transfers received data to on-chip RAM</p> <p data-bbox="804 411 1126 552">Calculates sum total of received sum value and 1 byte units of programming control program transferred to on-chip RAM</p> <p data-bbox="804 568 1111 620">If sum is 0, transmits H'AA to host</p> <p data-bbox="804 636 1120 687">If sum is not 0, transmits H'FF to host halts operation</p>
Memory erase	<p data-bbox="394 772 687 825">Transmits total erase status command (H'3A)</p>	<p data-bbox="804 703 1069 756">Starts total erase of flash memory</p> <p data-bbox="804 842 1114 952">Transmits H'11 to host if total erase processing is being executed when total erase status command is received</p> <p data-bbox="804 968 1114 1078">Transmits H'06 to host if total erase of all blocks has been completed when total erase status command is received</p>
	<p data-bbox="394 1134 715 1214">Retransmits total erase status command (H'3A) when H'11 is received</p>	<p data-bbox="804 1094 1114 1235">If erase cannot be performed when total erase status command is received, transmits H'EE to host and halts operation</p>
Execution of programming control program		<p data-bbox="804 1254 1120 1364">Branches to programming control program transferred to on-chip RAM and starts execution.</p>

### 17.6.3 Programming/Erasing in User Program Mode

On-board programming/erasing of an individual flash memory block can also be performed in user program mode by branching to a user program/erase control program. The user must set branching conditions and provide on-board FWE control and supply of programming data, and storing a program/erase control program in part of the program area as necessary. The flash memory must contain the user program/erase control program or a program which provides the user program/erase control program from external memory. Because the flash memory itself cannot be read during programming/erasing, transfer the user program/erase control program to on-chip RAM, as like in boot mode. Figure 17.10 shows a sample procedure for programming/erasing in user program mode. Prepare a user program/erase control program in accordance with the description in section 17.8, Flash Memory Programming/Erasing.



**Figure 17.10 Programming/Erasing Flowchart Example in User Program Mode**



## 17.7 Flash Memory Emulation in RAM

Making a setting in the RAM emulation register (RAMER) enables part of RAM to be overlapped onto the flash memory area so that data to be written to flash memory can be emulated in RAM in real time. Emulation can be performed in user mode or user program mode. Figure 17.11 shows an example of emulation of real-time flash memory programming.

1. Set RAMER to overlap part of RAM onto the area for which real-time programming is required.
2. Emulation is performed using the overlapping RAM.
3. After the program data has been confirmed, the RAMS bit is cleared, thus releasing RAM overlap.
4. The data written in the overlapping RAM is written into the flash memory space (EB0).

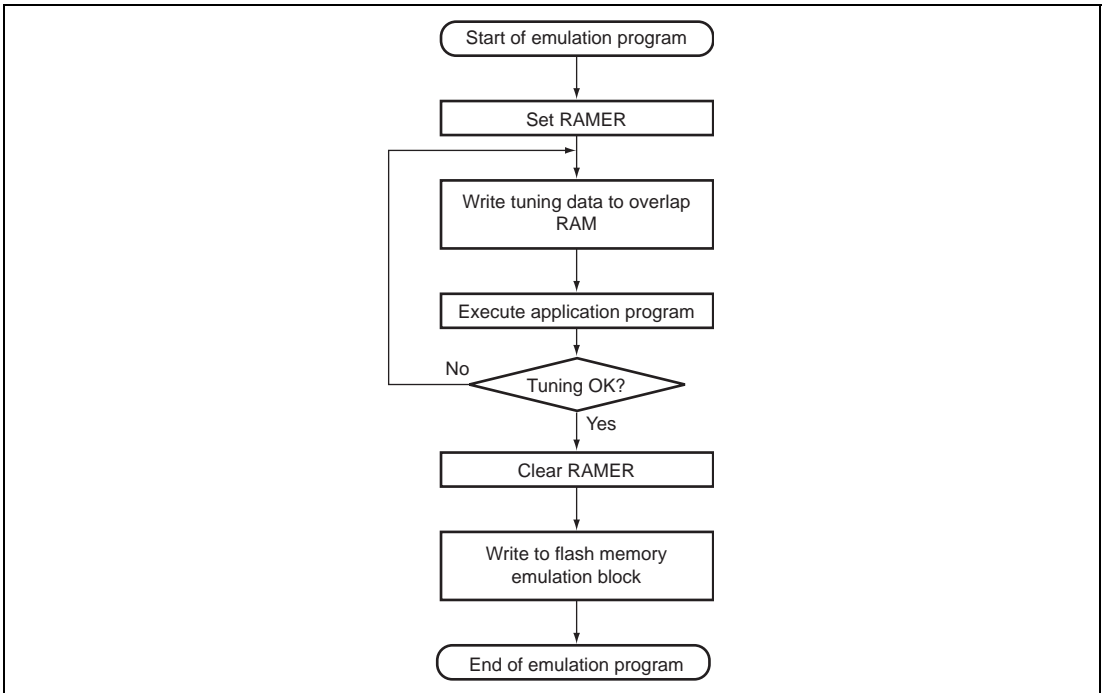
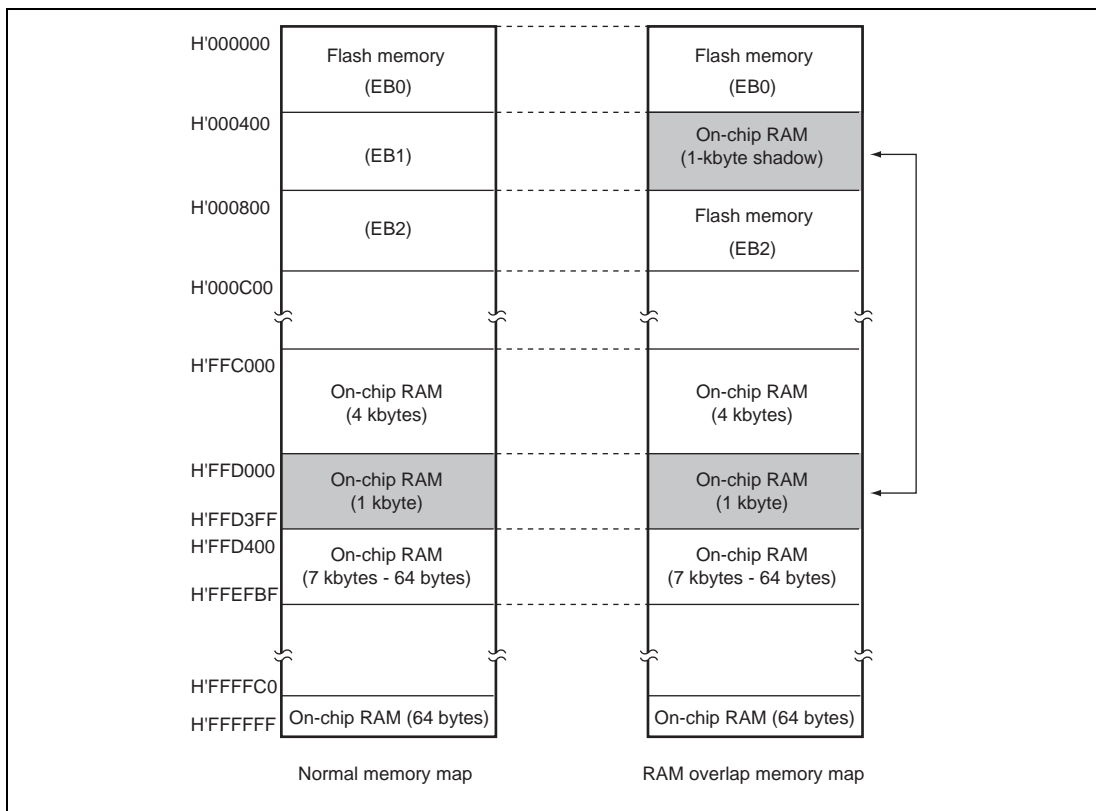


Figure 17.11 Flowchart for Flash Memory Emulation in RAM

An example in which flash memory block area EB0 is overlapped is shown in Figure 17.12.

1. The RAM area to be overlapped is fixed at a 1-kbyte area in the range of H'FFD000 to H'FFD3FF.
2. The flash memory area to overlap is selected by RAMER from a 1-kbyte area among one of the EB0 to EB3 blocks.
3. The overlapped RAM area can be accessed from both the flash memory addresses and RAM addresses.
4. When the RAMS bit in RAMER is set to 1, program/erase protection is enabled for all flash memory blocks (emulation protection). In this state, setting the P1 or E1 bit in FLMCR1 to 1 does not cause a transition to program mode or erase mode.
5. A RAM area cannot be erased by execution of software in accordance with the erase algorithm.
6. Block area EB0 contains the vector table. When performing RAM emulation, the vector table is needed in the overlap RAM.



**Figure 17.12 Example of RAM Overlap Operation**

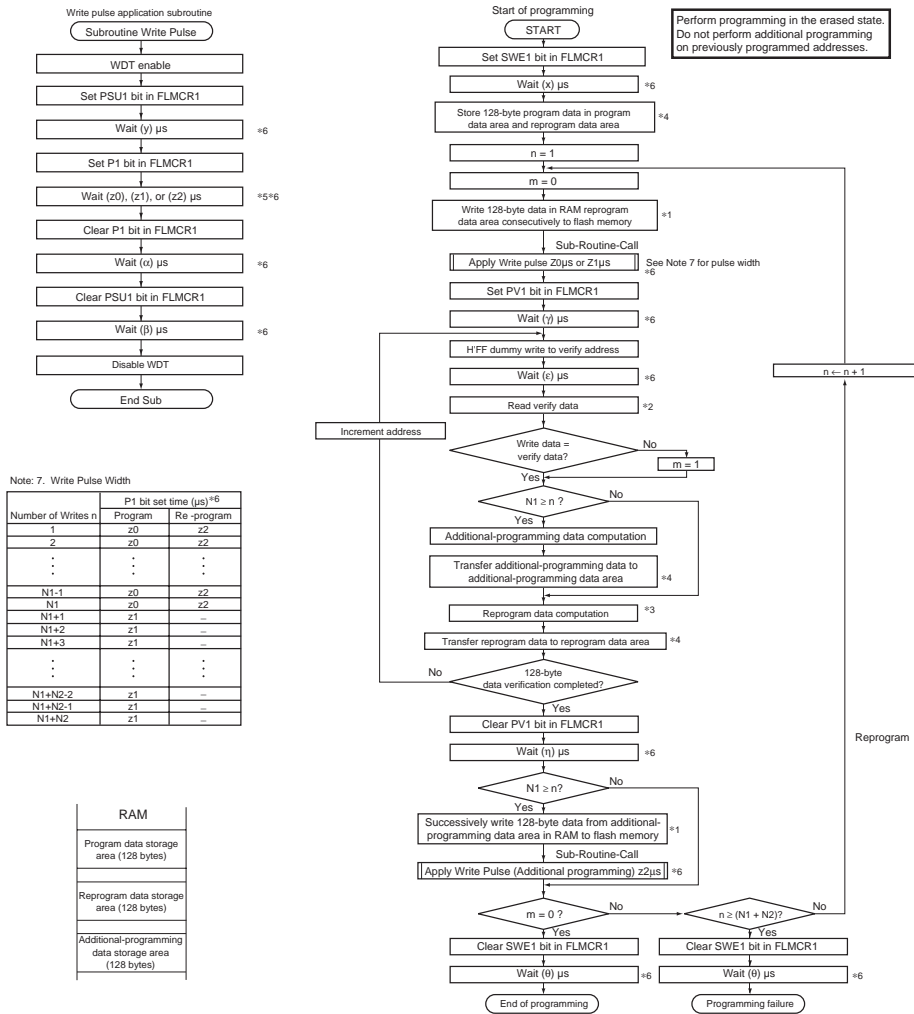
## 17.8 Flash Memory Programming/Erasing

A software method, using the CPU, is employed to program and erase flash memory in the on-board programming modes. Depending on the FLMCR1 setting, the flash memory operates in one of the following four modes: program mode, erase mode, program-verify mode, and erase-verify mode. The programming control program in boot mode and the user program/erase control program in user program mode use these operating modes in combination to perform programming/erasing. Flash memory programming and erasing should be performed in accordance with the descriptions in section 17.8.1, Program/Program-Verify and section 17.8.2, Erase/Erase-Verify, respectively.

### 17.8.1 Program/Program-Verify

When writing data or programs to the flash memory, the program/program-verify flowchart shown in Figure 17.13 should be followed. Performing programming operations according to this flowchart will enable data or programs to be written to the flash memory without subjecting the chip to voltage stress or sacrificing program data reliability.

1. Programming must be done to an empty address. Do not reprogram an address to which programming has already been performed.
2. Programming should be carried out 128 bytes at a time. A 128-byte data transfer must be performed even if writing fewer than 128 bytes. In this case, H'FF data must be written to the extra addresses.
3. Prepare the following data storage areas in RAM: a 128-byte programming data area, a 128-byte reprogramming data area, and a 128-byte additional-programming data area. Perform reprogramming data computation and additional programming data computation according to Figure 17.13.
4. Consecutively transfer 128 bytes of data in byte units from the reprogramming data area or additional-programming data area to the flash memory. The program address and 128-byte data are latched in the flash memory. The lower 8 bits of the start address in the flash memory destination area must be H'00 or H'80.
5. The time during which the P1 bit is set to 1 is the programming time. Figure 17.13 shows the allowable programming times.
6. The watchdog timer (WDT) is set to prevent overprogramming due to program runaway, etc. An overflow cycle of approximately  $(\gamma + z1 + \alpha + \beta)$   $\mu$ s is allowed.
7. For a dummy write to a verify address, write 1-byte data H'FF to an address whose lower 1 bit is B'0. Verify data can be read in words from the address to which a dummy write was performed.
8. The maximum number of repetitions of the program/program-verify sequence to the same bit is  $(N1 + N2)$ .



- Notes:
- Data transfer is performed by byte transfer. The lower 8 bits of the first address written to must be H'00 or H'80. A 128-byte data transfer must be performed even if writing fewer than 128 bytes; in this case, H'FF data must be written to the extra addresses.
  - Verify data is read in 16-bit (word) units.
  - Reprogram data is determined by the operation shown in the table below (comparison between the data stored in the program data area and the verify data). Bits for which the reprogram data is 0 are reprogrammed in the next reprogramming loop. Therefore, even bits for which programming has been completed will be subjected to programming once again if the result of the subsequent verify operation is NG. The contents of the reprogram data area and additional data area are modified as programming proceeds.
  - A 128-byte area for storing program data, a 128-byte area for storing reprogram data, and a 128-byte area for storing additional data must be provided in RAM.
  - A write pulse of z0 or z1 is applied according to the progress of the programming operation. See note 7 for details of the pulse widths. When writing of additional-programming data is executed, a z2 write pulse should be applied. Reprogram data 'X' means reprogram data when the write pulse is applied.
  - x, y, z0, z1, z2, α, β, γ, ε, η, θ, N1, and N2 are shown in section 22.7, Flash Memory Characteristics.

Reprogram Data Computation Table

Original Data (D)	Verify Data (V)	Reprogram Data (X)	Comments
0	0	1	Programming completed
0	1	0	Programming incomplete; reprogram
1	0	1	Still in erased state; no action
1	1	1	Still in erased state; no action

Additional-Programming Data Computation Table

Reprogram Data (X)	Verify Data (V)	Additional-Programming Data (Y)	Comments
0	0	0	Additional programming to be executed
0	1	1	Additional programming not to be executed
1	0	1	Additional programming not to be executed
1	1	1	Additional programming not to be executed

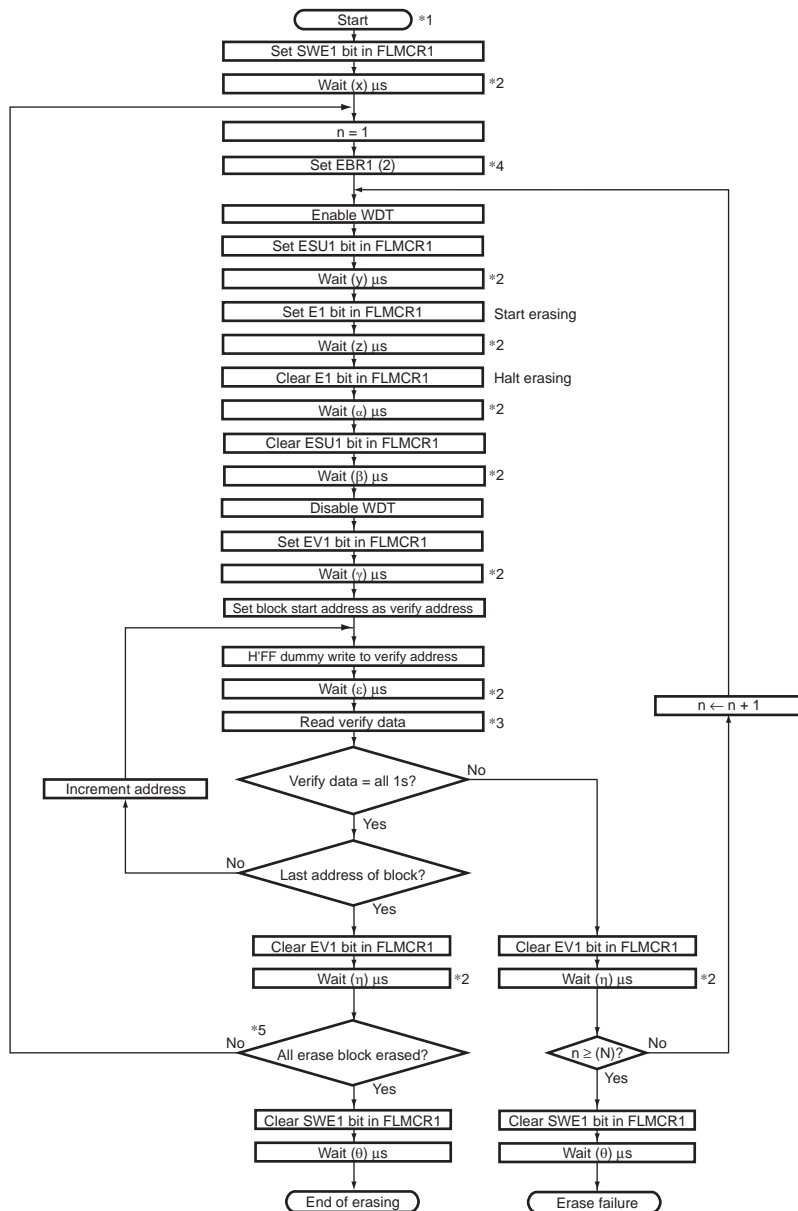
Figure 17.13 Program/Program-Verify Flowchart



### 17.8.2 Erase/Erase-Verify

When erasing flash memory, the erase/erase-verify flowchart shown in Figure 17.14 should be followed.

1. Prewriting (setting erase block data to all 0s) is not necessary.
2. Erasing is performed in block units. Make only a single-bit specification in the erase block register 1, 2 (EBR1, EBR2). To erase multiple blocks, each block must be erased in turn.
3. The time during which the E1 bit is set to 1 is the flash memory erase time.
4. The watchdog timer (WDT) is set to prevent overprogramming due to program runaway, etc. An overflow cycle of approximately  $(y+z+\alpha+\beta)$  ms is allowed.
5. For a dummy write to a verify address, write 1-byte data H'FF to an address whose lower 1 bit is B'0. Verify data can be read in longwords from the address to which a dummy write was performed.
6. If the read data is unerased, set erase mode again, and repeat the erase/erase-verify sequence as before. The maximum number of repetitions of the erase/erase-verify sequence is N.



- Notes:
1. Pre-write (clearing data in the block to be erased to 0) isn't required.
  2. x, y, z, α, β, γ, ε, η, θ, and N are shown in section 22.7, Flash Memory Characteristics.
  3. Verify data is read in 16 bits.
  4. Only 1 bit in the EBR register must be set. Two or more bits in EBR cannot be set.
  5. Erasure is performed in block units. To erase multiple blocks, each block must be erased sequentially.

**Figure 17.14 Erase/Erase-Verify Flowchart**

## 17.9 Program/Erase Protection

There are three kinds of flash memory program/erase protection: hardware protection, software protection, and error protection.

### 17.9.1 Hardware Protection

Hardware protection refers to a state in which programming/erasing of flash memory is forcibly disabled or aborted because of a transition to reset or standby mode. Flash memory control register 1 (FLMCR1), flash memory control register 2 (FLMCR2), erase block register 1 (EBR1), and erase block register 2 (EBR2) are initialized. In a reset via the  $\overline{\text{RES}}$  pin, the reset state is not entered unless the  $\overline{\text{RES}}$  pin is held low until oscillation stabilizes after powering on. In the case of a reset during operation, hold the  $\overline{\text{RES}}$  pin low for the  $\overline{\text{RES}}$  pulse width specified in the AC Characteristics section.

### 17.9.2 Software Protection

Software protection can be implemented against programming/erasing of all flash memory blocks by clearing the SWE1 bit in FLMCR1. When software protection is in effect, setting the P1 or E1 bit in FLMCR1 does not cause a transition to program mode or erase mode. By setting the erase block register 1 (EBR1), and erase block register 2 (EBR2), erase protection can be set for individual blocks. When EBR1 and EBR2 are set to H'00, erase protection is set for all blocks.

### 17.9.3 Error Protection

In error protection, an error is detected when the CPU's runaway occurs during flash memory programming/erasing, or operation is not performed in accordance with the program/erase algorithm, and the program/erase operation is aborted. Aborting the program/erase operation prevents damage to the flash memory due to overprogramming or overerasing.

When the following errors are detected during programming/erasing of flash memory, the FLER bit in FLMCR2 is set to 1, and the error protection state is entered.

Setting Conditions of FLER Bit (Erase Protection)

- When the flash memory of the relevant address area is read during programming/erasing (including vector read and instruction fetch)
- Immediately after exception handling (excluding a reset) during programming/erasing
- When a SLEEP instruction is executed during programming/erasing
- When the CPU releases the bus mastership to the DMAC during programming/erasing

The FLMCR1, FLMCR2, EBR1 and EBR2 settings are retained, but program mode or erase mode is aborted at the point at which the error occurred. Program mode or erase mode cannot be re-entered by re-setting the P1 or E1 bit. However, PV1 and EV1 bit setting is enabled, and a transition can be made to verify mode.

## 17.10 Interrupt Handling when Programming/Erasing Flash Memory

All interrupts, including NMI interrupt is disabled when flash memory is being programmed or erased (when the P1 or E1 bit is set in FLMCR1), and while the boot program is executing in boot mode\*<sup>1</sup>, to give priority to the program or erase operation. There are three reasons for this:

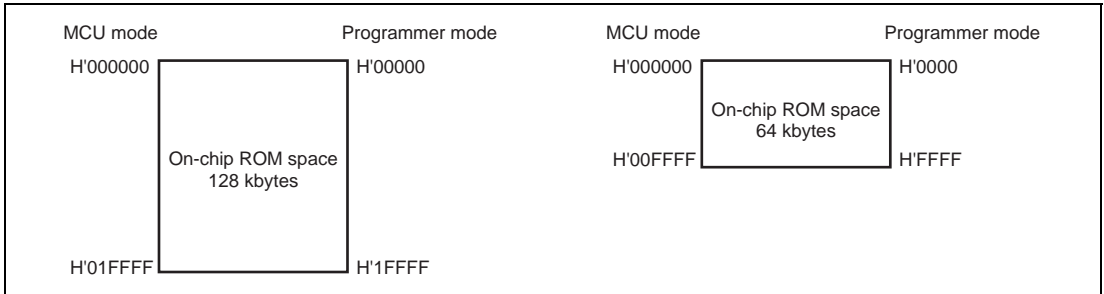
1. Interrupt during programming or erasing might cause a violation of the programming or erasing algorithm, with the result that normal operation could not be assured.
2. In the interrupt exception handling sequence during programming or erasing, the vector would not be read correctly\*<sup>2</sup>, possibly resulting in CPU runaway.
3. If interrupt occurred during boot program execution, it would not be possible to execute the normal boot mode sequence.

- Notes:
1. Interrupt requests must be disabled inside and outside the CPU until the programming control program has completed programming.
  2. The vector may not be read correctly in this case for the following two reasons:
    - If flash memory is read while being programmed or erased (while the P1 or E1 bit is set in FLMCR1), correct read data will not be obtained (undetermined values will be returned).
    - If the interrupt entry in the vector table has not been programmed yet, interrupt exception handling will not be executed correctly.



## 17.11 Programmer Mode

In programmer mode, a PROM programmer can perform programming/erasing via a socket adapter, just like for a discrete flash memory. Use a PROM programmer that supports the Renesas Technology 128-kbyte or 64-kbyte flash memory on-chip MCU device type. Memory map in programmer mode is shown in Figure 17.15.



**Figure 17.15 Memory Map in Programmer Mode**

## 17.12 Power-Down States for Flash Memory

In user mode, the flash memory will operate in either of the following states:

- Normal operating mode  
The flash memory can be read and written to.
- Standby mode  
All flash memory circuits are halted.
- Power-down state  
The flash memory can be read when part of the power supply circuit is halted and the LSI operates by subclocks.

Table 17.8 shows the correspondence between the operating modes of this LSI and the flash memory. When the flash memory returns to normal operation from a power-down state, a power supply circuit stabilization period is needed. When the flash memory returns to its normal operating state from watch mode or standby mode, bits STS2 to STS0 in SBYCR must be set to provide a wait time of at least 100  $\mu$ s; when returns from flash memory module stop mode, the software wait state should be set.

**Table 17.8 Flash Memory Operating States**

<b>LSI Operating State</b>	<b>Flash Memory Operating State</b>
Active mode	Normal operating mode
Sleep mode	
Watch mode	Standby mode
Standby mode	(Before entering to the normal operation mode, wait time of at least 100 $\mu$ s is required.)
Flash memory module stop mode	
Subactive mode	Power-down mode (read only)
Subsleep mode	

## 17.13 Flash Memory Programming and Erasing Precautions

Precautions concerning the use of on-board programming mode, the RAM emulation function, and PROM mode are summarized below.

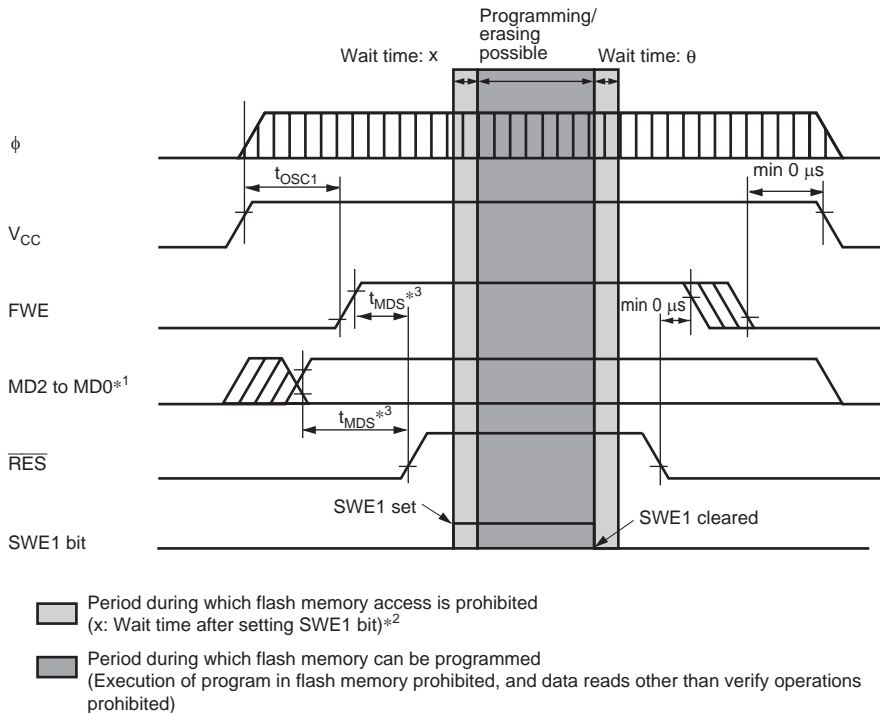
- Use the specified voltages and timing for programming and erasing.  
Applied voltages in excess of the rating can permanently damage the device. Use a PROM programmer that supports the Renesas Technology microcomputer device type with on-chip flash memory (FZTAT128V3A, FZTAT64V3A).  
Do not select the HN27C4096 setting for the PROM programmer, and only use the specified socket adapter. Failure to observe these points may result in damage to the device.
- Powering on and off  
Do not apply a high level to the FWE pin until VCC has stabilized. Also, drive the FWE pin low before turning off VCC. When applying or disconnecting VCC power, fix the FWE pin low and place the flash memory in the hardware protection state. The power-on and power-off timing requirements should also be satisfied in the event of a power failure and subsequent recovery.
- FWE application/disconnection  
FWE application should be carried out when MCU operation is in a stable condition. If MCU operation is not stable, fix the FWE pin low and set the protection state. The following points must be observed concerning FWE application and disconnection to prevent unintentional programming or erasing of flash memory:
  - Apply FWE when the VCC voltage has stabilized within its rated voltage range.
  - In boot mode, apply and disconnect FWE during a reset.
  - In user program mode, FWE can be switched between high and low level regardless of the reset state. FWE input can also be switched during execution of a program in flash memory.
  - Do not apply FWE if program runaway has occurred.
  - Disconnect FWE only when the SWE1, ESU1, PSU1, EV1, PV1, P1, and E1 bits in FLMCR1 are cleared. Make sure that the SWE1, ESU1, PSU1, EV1, PV1, P1, and E1 bits are not set by mistake when applying or disconnecting FWE.
- Do not apply a constant high level to the FWE pin.  
Apply a high level to the FWE pin only when programming or erasing flash memory. A system configuration in which a high level is constantly applied to the FWE pin should be avoided. Also, while a high level is applied to the FWE pin, the watchdog timer should be activated to prevent overprogramming or overerasing due to program runaway, etc.

- Use the recommended algorithm when programming and erasing flash memory.  
The recommended algorithm enables programming and erasing to be carried out without subjecting the device to voltage stress or sacrificing program data reliability. When setting the P1 or E1 bit in FLMCR1, the watchdog timer should be set beforehand as a precaution against program runaway, etc.
- Do not set or clear the SWE1 bit during execution of a program in flash memory.  
Wait at least  $0 \mu\text{s}^*$  after clearing the SWE1 bit before executing a program or reading data in flash memory. When the SWE1 bit is set, data in flash memory can be rewritten, but access flash memory only for verify operations (verification during programming/erasing). Also, do not clear the SWE1 bit during programming, erasing, or verifying. Similarly, when using emulation by RAM with a high level applied to the FWE pin, the SWE1 bit should be cleared before executing a program or reading data in flash memory. However, read/write accesses can be performed in the RAM area overlapping the flash memory space regardless of whether the SWE1 bit is set or cleared.

Note: \* Refer to section 22.7, Flash Memory Characteristics.

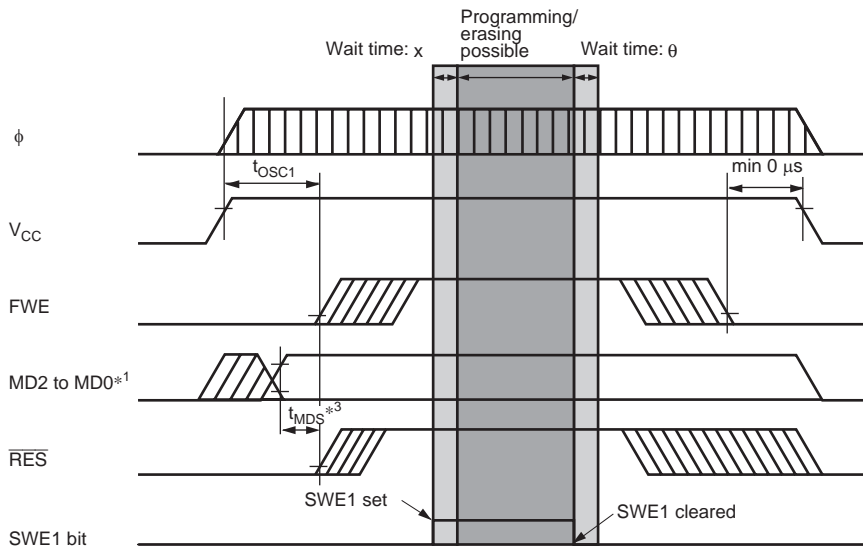
- Do not use interrupts while flash memory is being programmed or erased.  
All interrupt requests, including NMI, should be disabled during FWE application to give priority to program/erase operations.
- Do not perform additional programming. Erase the memory before reprogramming.  
In on-board programming, perform only one programming operation on a 128-byte programming unit block. In programmer mode, too, perform only one programming operation on a 128-byte programming unit block. Programming should be carried out with the entire programming unit block erased.
- Before programming, check that the chip is correctly mounted in the PROM programmer.  
Overcurrent damage to the device can result if the index marks on the PROM programmer socket, socket adapter, and chip are not correctly aligned.
- Do not touch the socket adapter or chip during programming.  
Touching either of these can cause contact faults and write errors.
- The reset state must be entered after powering on  
Apply the reset signal for at least  $100 \mu\text{s}$  during the oscillation setting period.
- When a reset is applied during operation, this should be done while the SWE1 pin is low.  
Wait at least  $0 \mu\text{s}^*$  after clearing the SWE1 bit before applying the reset.


Note: \* Refer to section 22.7, Flash Memory Characteristics.




- Notes:
1. Except when switching modes, the level of the mode pins (MD2 to MD0) must be fixed until power-off by pulling the pins up or down.
  2. See section 22.7, Flash Memory Characteristics.
  3. Mode programming setup time  $t_{MDS}$  (min) = 200 ns.

**Figure 17.16 Power-On/Off Timing (Boot Mode)**

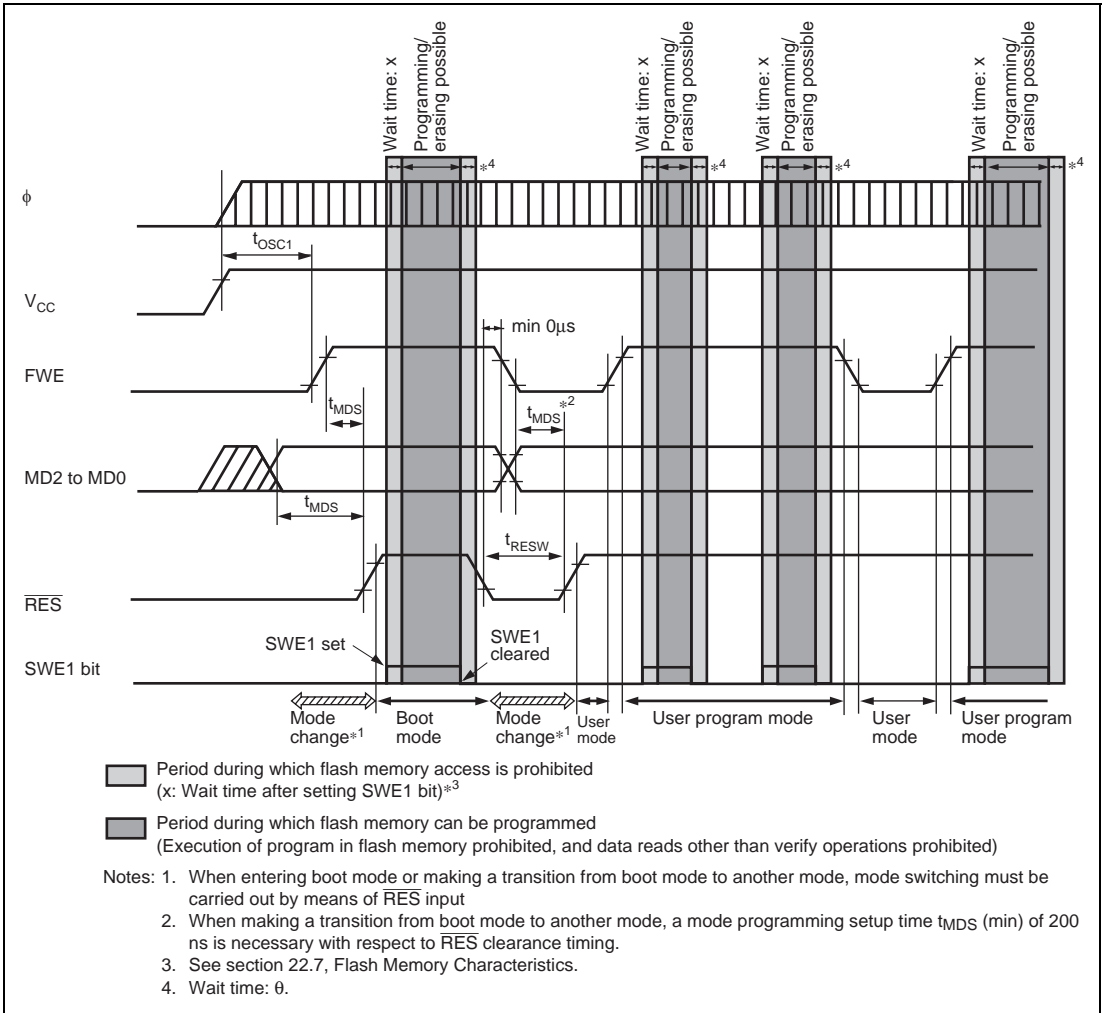


 Period during which flash memory access is prohibited (x: Wait time after setting SWE1 bit)<sup>\*2</sup>

 Period during which flash memory can be programmed (Execution of program in flash memory prohibited, and data reads other than verify operations prohibited)

- Notes: 1. Except when switching modes, the level of the mode pins (MD2 to MD0) must be fixed until power-off by pulling the pins up or down.  
 2. See section 22.7, Flash Memory Characteristics.  
 3. Mode programming setup time  $t_{MDS}$  (min) = 200 ns.

**Figure 17.17 Power-On/Off Timing (User Program Mode)**



**Figure 17.18 Mode Transition Timing**  
**(Example: Boot Mode → User Mode ↔ User Program Mode)**

## 17.14 Note on Switching from F-ZTAT Version to Masked ROM Version

The masked ROM version does not have the internal registers for flash memory control that are provided in the F-ZTAT version. Table 17.9 lists the registers that are present in the F-ZTAT version but not in the masked ROM version. If a register listed in table 17.9 is read in the masked ROM version, an undefined value will be returned. Therefore, if application software developed on the F-ZTAT version is switched to a masked ROM version product, it must be modified to ensure that the registers in table 17.9 have no effect.

**Table 17.9 Registers Present in F-ZTAT Version but Absent in Masked ROM Version**

<b>Register</b>	<b>Abbreviation</b>	<b>Address</b>
Flash memory control register 1	FLMCR1	H'FFA8
Flash memory control register 2	FLMCR2	H'FFA9
Erase block register 1	EBR1	H'FFAA
Erase block register 2	EBR2	H'FFAB
RAM emulation register	RAMER	H'FEDB
Serial control register x	SCRX	H'FDB4



## Section 18 Masked ROM

This LSI incorporates a masked ROM which has the following features.

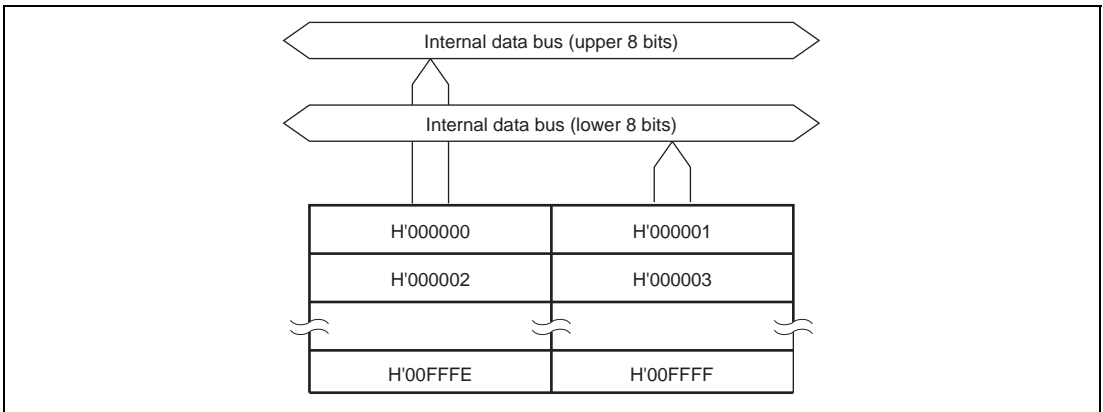
### 18.1 Features

- Size

Product Class		ROM Size	ROM Address (Modes 6 and 7)
H8S/2218 Group	HD6432217	64 kbytes	H'000000 to H'00FFFF
H8S/2212 Group	HD6432211	64 kbytes	H'000000 to H'00FFFF
	HD6432210, HD6432210S	32 kbytes	H'000000 to H'007FFF

- Connected to the bus master through 16-bit data bus, enabling one-state access to both byte data and word data.

Figure 18.1 shows a block diagram of the on-chip masked ROM.

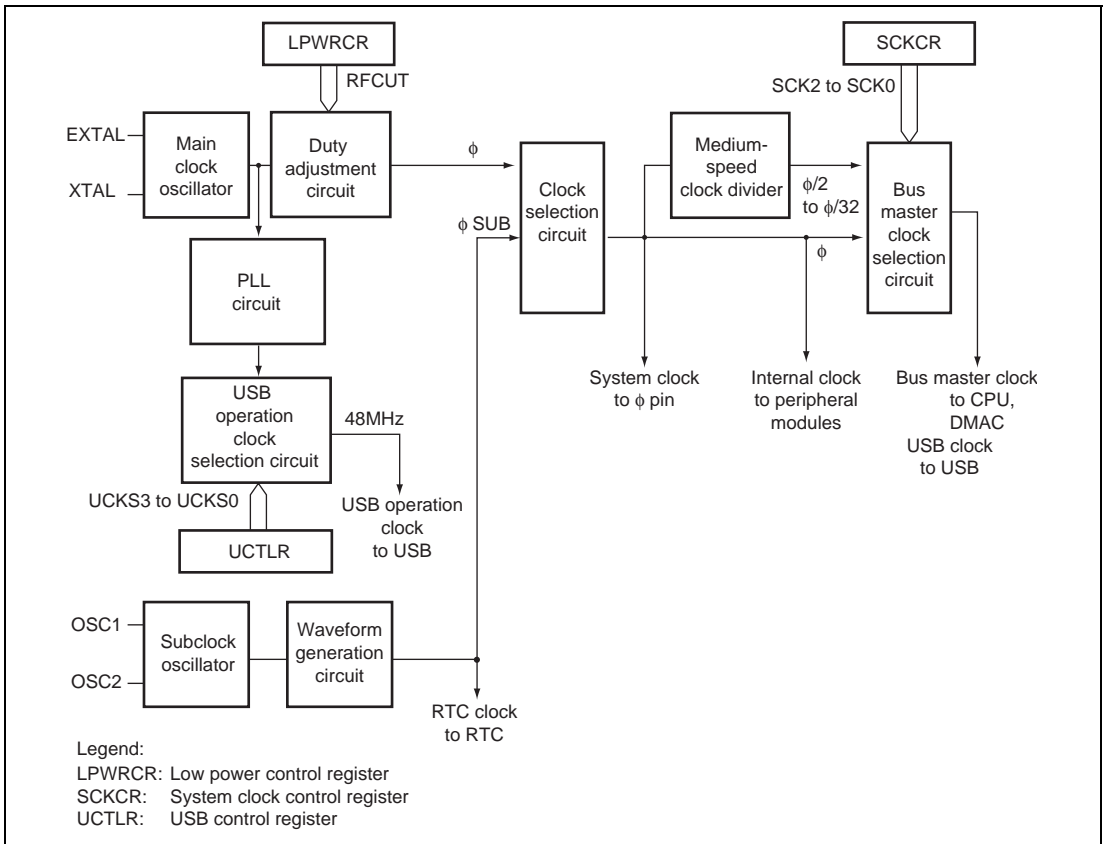


**Figure 18.1 Block Diagram of On-Chip Masked ROM (64 kbytes)**



## Section 19 Clock Pulse Generator

This LSI has an on-chip clock pulse generator that generates the system clock ( $\phi$ ), the bus master clock, and internal clocks. The clock pulse generator consists of a main clock oscillator, duty adjustment circuit, clock select circuit, medium-speed clock divider, bus master clock selection circuit, subclock oscillator, waveform shaping circuit, PLL (Phase Locked Loop) circuit, and USB operating clock selection circuit. A block diagram of clock pulse generator is shown in figure 19.1.



**Figure 19.1 Block Diagram of Clock Pulse Generator**

The frequency of the main clock oscillator can be changed by software by means of settings in the low-power control register (LPWRCR) and system clock control register (SCKCR). PLL 48-MHz clock can be selected by software by means of setting the USB control register (UCTLR). For details, refer to section 14, Universal Serial Bus (USB).

## 19.1 Register Descriptions

The on-chip clock pulse generator has the following registers.

- System clock control register (SCKCR)
- Low-power control register (LPWRCR)

### 19.1.1 System Clock Control Register (SCKCR)

SCKCR controls  $\phi$  clock output and medium-speed mode.

Bit	Bit Name	Initial Value	R/W	Description
7	PSTOP	0	R/W	<p><math>\phi</math> Clock Output Disable</p> <p>Controls <math>\phi</math> output. The operation of this bit changes depending on the operating mode. For details, see section 20.11, <math>\phi</math> Clock Output Disabling Function.</p> <p>0: <math>\phi</math> output, fixed high, or high impedance 1: Fixed high or high impedance</p>
6	—	0	R/W	<p>Reserved</p> <p>Although this bit is readable/writable, only 0 should be written to.</p>
5, 4	—	All 0	—	<p>Reserved</p> <p>These bits are always read as 0.</p>
3	—	0	R/W	<p>Reserved</p> <p>Although this bit is readable/writable, only 0 should be written to.</p>

Bit	Bit Name	Initial Value	R/W	Description
2	SCK2	0	R/W	System Clock Select 2 to 0
1	SCK1	0	R/W	These bits select the bus master clock. To operate in subactive mode or watch mode, clear the SCK2 to SCK0 bits to 0. 000: High-speed mode 001: Medium-speed clock is $\phi/2$ 010: Medium-speed clock is $\phi/4$ 011: Medium-speed clock is $\phi/8$ 100: Medium-speed clock is $\phi/16$ 101: Medium-speed clock is $\phi/32$ 11x: Setting prohibited
0	SCK0	0	R/W	

Legend:

x: Don't care

### 19.1.2 Low Power Control Register (LPWRCR)

LPWRCR performs power-down mode control, selects sampling frequency for eliminating noise, performs subclock oscillator control, and selects whether or not built-in feedback resistance and duty adjustment circuit of the system clock generator used.

Bit	Bit Name	Initial Value	R/W	Description
7	DTON	0	R/W	Direct Transition ON Flag 0: When the SLEEP instruction is executed in high-speed mode or medium-speed mode, operation shifts to sleep mode, software standby mode, or watch mode*. When the SLEEP instruction is executed in subactive mode, operation shifts to subsleep mode or watch mode. 1: When the SLEEP instruction is executed in high-speed mode or medium-speed mode, operation shifts directly to subactive mode, or shifts to sleep mode or software standby mode. When the SLEEP instruction is executed in subactive mode, operation shifts directly to high-speed mode, or shifts to subsleep mode.

Bit	Bit Name	Initial Value	R/W	Description
6	LSON	0	R/W	<p>Low Speed ON Flag</p> <p>0: When the SLEEP instruction is executed in high-speed mode or medium-speed mode, operation shifts to sleep mode, software standby mode, or watch mode*.</p> <p>When the SLEEP instruction is executed in subactive mode, operation shifts to watch mode* or shifts directly to high-speed mode.</p> <p>Operation shifts to high-speed mode when watch mode is cancelled.</p> <p>1: When the SLEEP instruction is executed in high-speed mode*, operation shifts to watch mode or subactive mode*.</p> <p>When the SLEEP instruction is executed in subactive mode, operation shifts to subsleep mode or watch mode.</p> <p>Operation shifts to subactive mode when watch mode is cancelled.</p>
5	NESEL	0	R/W	<p>Noise Elimination Sampling Frequency Select</p> <p>This bit selects the sampling frequency of the subclock (<math>\phi_{SUB}</math>) generated by the subclock oscillator is sampled by the clock (<math>\phi</math>) generated by the system clock oscillator</p> <p>0: Sampling using <math>1/32 \times \phi</math></p> <p>1: Sampling using <math>1/4 \times \phi</math></p>
4	SUBSTP	0	R/W	<p>Subclock Enable</p> <p>This bit enables/disables subclock generation. This bit should be set to 1 when subclock is not used.</p> <p>0: Enables subclock generation.</p> <p>1: Disables subclock generation.</p>

Bit	Bit Name	Initial Value	R/W	Description
3	RFCUT	0	R/W	<p>Built-in Feedback Resistor Control</p> <p>Selects whether the oscillator's built-in feedback resistor and duty adjustment circuit are used with external clock input. This bit should not be accessed when a crystal oscillator is used.</p> <p>After this bit is set when using external clock input, a transition should initially be made to software standby mode. Switching between use and non-use of the oscillator's built-in feedback resistor and duty adjustment circuit is performed when the transition is made to software standby mode.</p> <p>0: Main clock oscillator's built-in feedback resistor and duty adjustment circuit are used</p> <p>1: Main clock oscillator's built-in feedback resistor and duty adjustment circuit are not used</p>
2	—	0	R/W	<p>Reserved</p> <p>This bit can be read from or written to, but the write value should always 0.</p>
1	STC1	0	R/W	Frequency Multiplication Factor
0	STC0	0	R/W	<p>Specify the frequency multiplication factor of the PLL circuit incorporated into the evaluation chip. The specified frequency multiplication factor is valid after a transition to software standby mode.</p> <p>With this LSI, the STC1 and STC0 bits must both be set to 1. After a reset, the STC1 and STC0 bits are both cleared to 0, and so they must be set to 1.</p> <p>00: <math>\times 1</math></p> <p>01: <math>\times 2</math> (Setting prohibited)</p> <p>10: <math>\times 4</math> (Setting prohibited)</p> <p>11: PLL is bypassed</p>

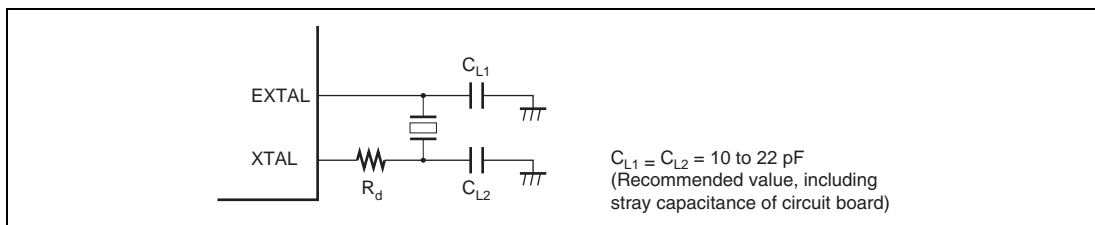
Note: \*When watch mode or subactive mode is entered, set high-speed mode.

## 19.2 System Clock Oscillator

Clock pulses can be supplied by connecting a crystal resonator, or by input of an external clock.

### 19.2.1 Connecting a Crystal Resonator

A crystal resonator can be connected as shown in the example in figure 19.2. Select the damping resistance  $R_d$  according to table 19.1. An AT-cut parallel-resonance crystal should be used.

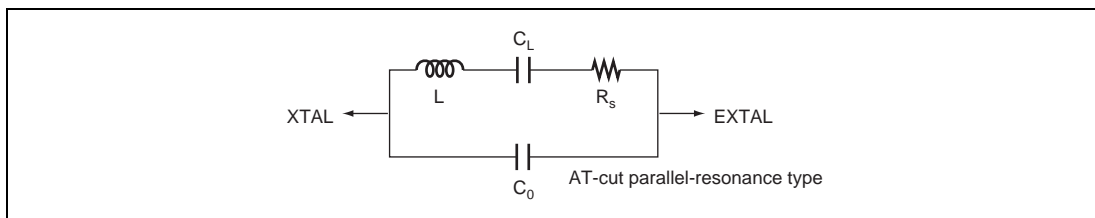


**Figure 19.2 Connection of Crystal Resonator (Example)**

**Table 19.1 Damping Resistance Value**

Frequency (MHz)	6	8	10	13	16	20	24
$R_d$ ( $\Omega$ )	300	200	100	0	0	0	0

Figure 19.3 shows the equivalent circuit of the crystal resonator. Use a crystal resonator that has the characteristics shown in table 19.2.



**Figure 19.3 Crystal Resonator Equivalent Circuit**

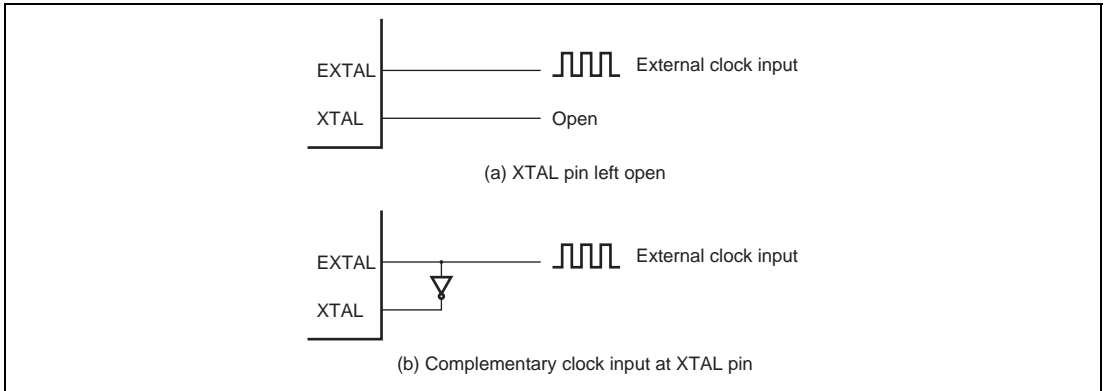
**Table 19.2 Crystal Resonator Characteristics**

Frequency (MHz)	6	8	10	13	16	20	24
$R_s$ max ( $\Omega$ )	100	80	60	60	50	40	40
$C_0$ max (pF)	7	7	7	7	7	7	7



## 19.2.2 Inputting External Clock

An external clock signal can be input as shown in an example in figure 19.4. If the XTAL pin is left open, make sure that stray capacitance is no more than 10 pF. When complementary clock input to XTAL pin, the external clock input should be fixed high in standby mode, subactive mode, subsleep mode, or watch mode.



**Figure 19.4 External Clock Input (Examples)**

Table 19.3 shows the input conditions for the external clock.

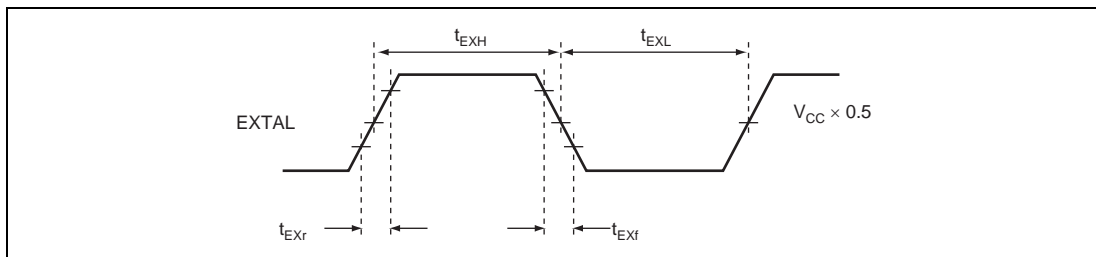
**Table 19.3 External Clock Input Conditions**

Item	Symbol	VCC = 2.4 to 3.6V		VCC = 2.7 to 3.6V		VCC = 3.0 to 3.6V		Unit	Test Conditions
		min	max	Min	max	min	max		
External clock input low pulse width	$t_{EXL}$	65	—	25	—	15.5	—	ns	Figure 19.5
External clock input high pulse width	$t_{EXH}$	65	—	25	—	15.5	—	ns	
External clock rise time	$t_{EXr}$	—	15	—	6.25	—	5.25	ns	
External clock fall time	$t_{EXf}$	—	15	—	6.25	—	5.25	ns	
Clock low pulse width level	$t_{CL}$	0.35	0.65	0.4	0.6	0.4	0.6	tcyc	Figure 22.3
Clock high pulse width level	$t_{CH}$	0.35	0.65	0.4	0.6	0.4	0.6	tcyc	

The external clock input conditions when the duty adjustment circuit is not used are shown in table 19.4. When the duty adjustment circuit is not used, note that the maximum operating frequency depends on the external clock input waveform. For example, if  $t_{EXL} = t_{EXH} = 20.8$  ns and  $t_{EXr} = t_{EXf} = 5.25$  ns, the maximum operating frequency becomes 19.2 MHz depending on the clock cycle time of 52.1 ns.

**Table 19.4 External Clock Input Conditions when Duty Adjustment Circuit Is not Used**

Item	Symbol	min	max	Min	max	min	max	Unit	Test
									Conditions
External clock input low pulse width	$t_{EXL}$	80	—	31.25	—	20.8	—	ns	Figure 19.5
External clock input high pulse width	$t_{EXH}$	80	—	31.25	—	20.8	—	ns	
External clock rise time	$t_{EXr}$	—	15	—	6.25	—	5.25	ns	
External clock fall time	$t_{EXf}$	—	15	—	6.25	—	5.25	ns	

**Figure 19.5 External Clock Input Timing**

### 19.3 Duty Adjustment Circuit

When the oscillator frequency is 5 MHz or higher, the duty adjustment circuit adjusts the duty cycle of the clock signal from the oscillator to generate the system clock ( $\phi$ ).

### 19.4 Medium-Speed Clock Divider

The medium-speed clock divider divides the system clock to generate  $\phi/2$ ,  $\phi/4$ ,  $\phi/8$ ,  $\phi/16$ , and  $\phi/32$ .

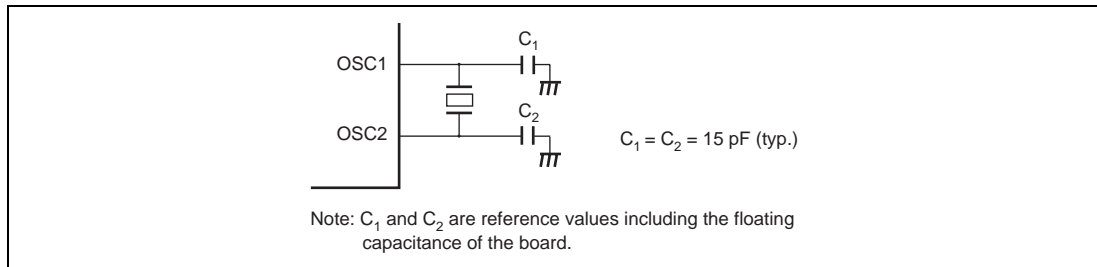
### 19.5 Bus Master Clock Selection Circuit

The bus master clock selection circuit selects the clock supplied to the bus master by setting the bits SCK2 to SCK0 in SCKCR. The bus master clock can be selected from high-speed mode, or medium-speed clocks ( $\phi/2$ ,  $\phi/4$ ,  $\phi/8$ ,  $\phi/16$ ,  $\phi/32$ ).

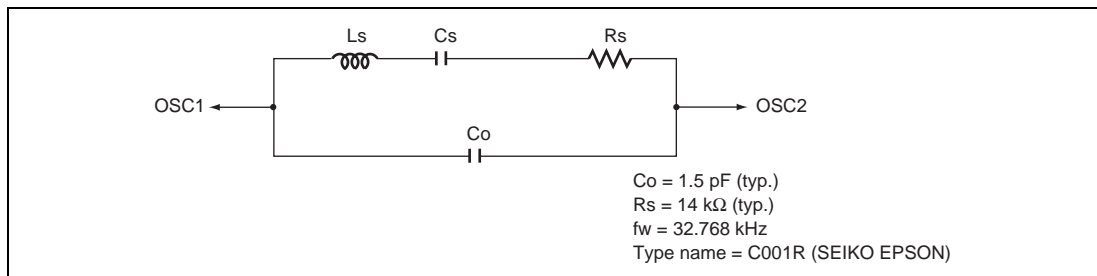
## 19.6 Subclock Oscillator

### 19.6.1 Connecting 32.768-kHz Crystal Resonator

supply a clock to the subclock divider, connect a 32.768-kHz crystal resonator, as shown in figure 19.6. Figure 19.7 shows the equivalence circuit for a 32.768-kHz oscillator.



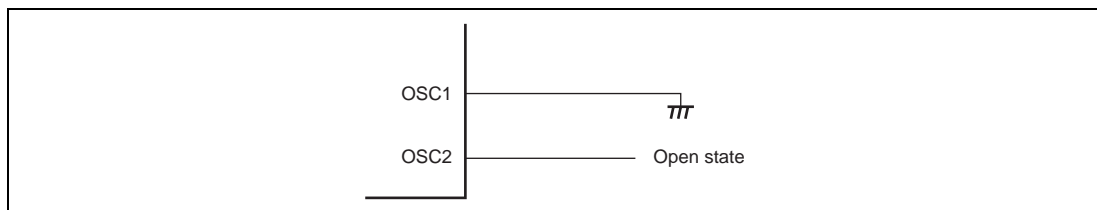
**Figure 19.6 Example Connection of 32.768-kHz Quartz Oscillator**



**Figure 19.7 Equivalence Circuit for 32.768-kHz Oscillator**

### 19.6.2 Handling Pins when Subclock Not Required

If no subclock is required, connect the OSC1 pin to  $V_{SS}$  and leave OSC2 open, as shown in figure 19.8. Set the SUBSTP bit of LPWRCCR to 1. If this setting is not made, transition to power-down mode may not complete properly in some cases.



**Figure 19.8 Pin Handling when Subclock Not Required**

## 19.7 Subclock Waveform Generation Circuit

To eliminate noise from the subclock input to OSCI, the subclock is sampled using the dividing clock  $\phi$ . The sampling frequency is set using the NESEL bit of LPWRCR. For details, see section 19.1.2, Low Power Control Register (LPWRCR).

No sampling is performed in subactive mode, subsleep mode, or watch mode.

## 19.8 PLL Circuit for USB

The PLL circuit has the function of doubling or tripling the 16-MHz or 24-MHz clock from the main oscillator to generate the 48-MHz USB operating clock.

When the PLL circuit is used, set the UCKS3 to UCKS0 bits of UCTLR. For details, refer to section 14, Universal Serial Bus (USB).

When the PLL circuit is not used, connect the PLVCC pin to Vcc and the PLLVSS pin to the ground (Vss). Figure 19.9 shows examples of external circuits peripheral to the PLL.

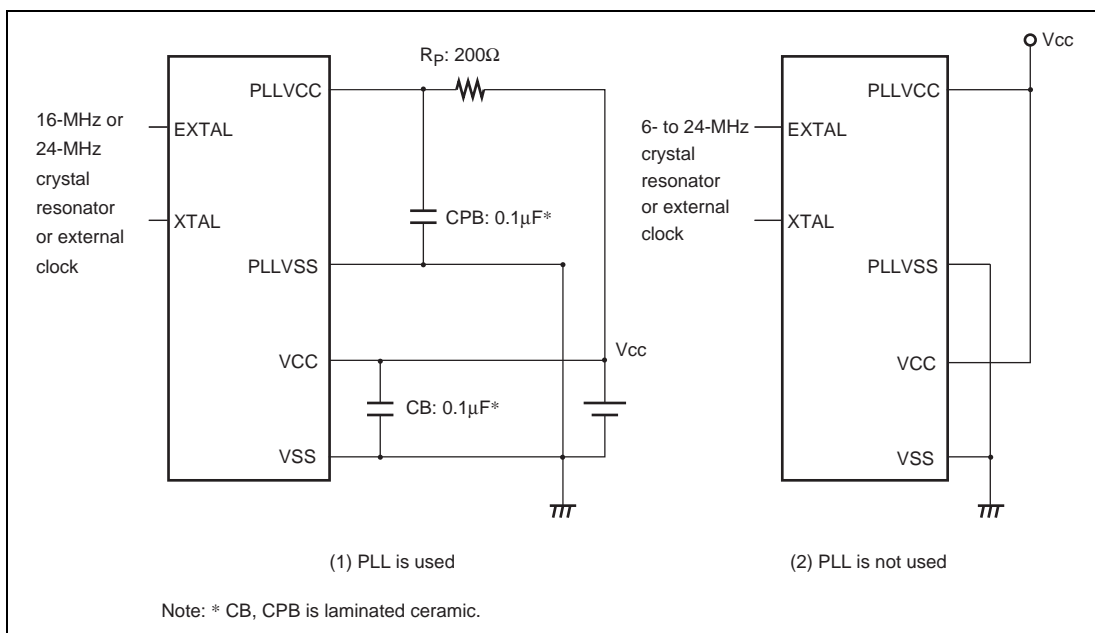


Figure 19.9 Example of PLL Circuit

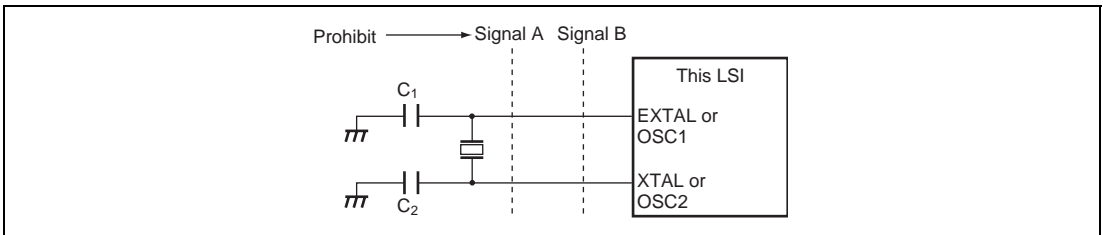
## 19.9 Usage Notes

### 19.9.1 Note on Crystal Resonator

Since various characteristics related to the crystal resonator are closely linked to the user's board design, thorough evaluation is necessary on the user's part, using the resonator connection examples shown in this section as a guide. As the resonator circuit ratings will depend on the floating capacitance of the resonator and the mounting circuit, the ratings should be determined in consultation with the resonator manufacturer. The design must ensure that a voltage exceeding the maximum rating is not applied to the oscillator pin.

### 19.9.2 Note on Board Design

When designing the board, place the crystal resonator and its load capacitors as close as possible to the XTAL or OSC1 and EXTAL or OSC2 pins. Other signal lines should be routed away from the oscillator circuit to prevent induction from interfering with correct oscillation. See figure 19.10.

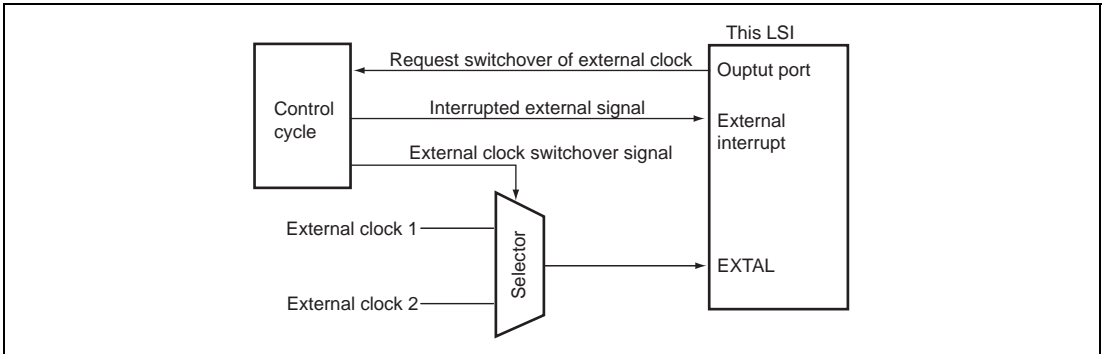


**Figure 19.10 Note on Board Design of Oscillator Circuit**

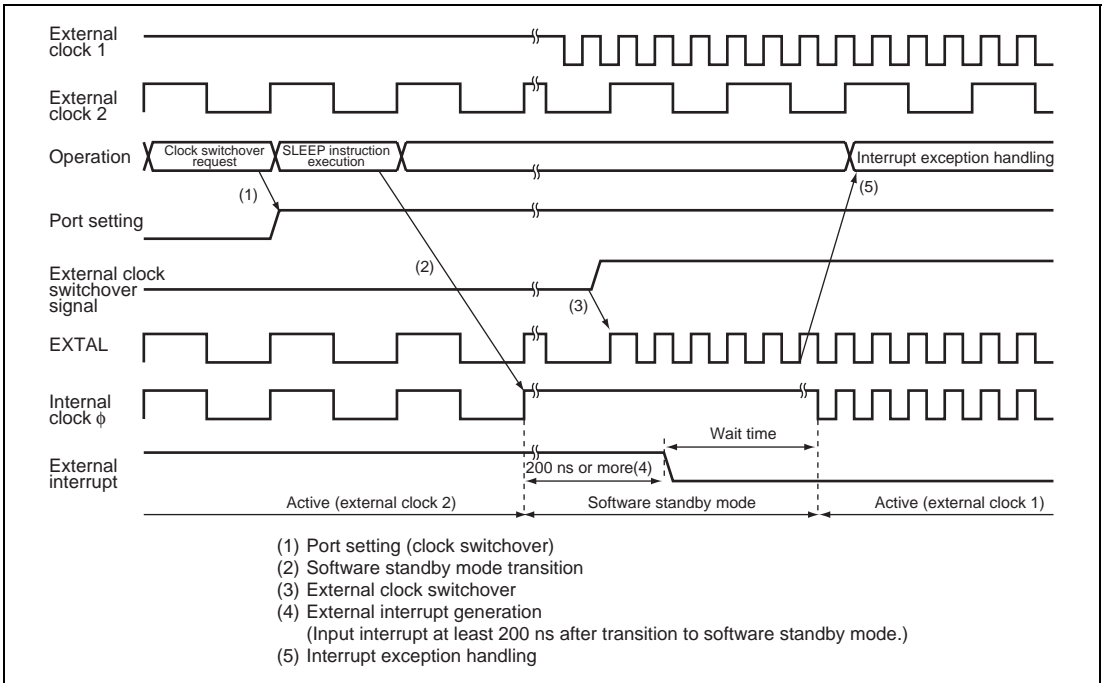
### 19.9.3 Note on Switchover of External Clock

When two or more external clocks (e.g. 16 MHz and 13 MHz) are used as the system clock, switchover of the input clock should be carried out in software standby mode.

An example of an external clock switching circuit is shown in figure 19.11, and an example of the external clock switchover timing in figure 19.12.



**Figure 19.11 Example of External Clock Switching Circuit**



**Figure 19.12 Example of External Clock Switchover Timing**

## Section 20 Power-Down Modes

In addition to the normal program execution state, this LSI has five power-down modes in which operation of the CPU and oscillator is halted and power dissipation is reduced. Low-power operation can be achieved by individually controlling the CPU, on-chip supporting modules, and so on.

This LSI's operating modes are high-speed mode and five power down modes:

1. Medium-speed mode
2. Subactive mode
3. Sleep mode
4. Subsleep mode
5. Watch mode
6. Module stop mode
7. Software standby mode
8. Hardware standby mode

1. to 5. are power-down modes. Sleep mode is CPU states, medium-speed mode is a CPU and bus master state, subactive mode is a CPU, bus master, and on-chip peripheral function state, and module stop mode is an internal peripheral function (including bus masters other than the CPU) state. Some of these states can be combined.

After a reset, the LSI is in high-speed mode, flash memory, and module stop mode (other than DMAC).

Table 20.1 and table 20.2 show the LSI internal states in each mode and the transition conditions of power-down modes respectively. Figure 20.1 shows the diagram of mode transition.

Table 20.1 LSI Internal States in Each Mode

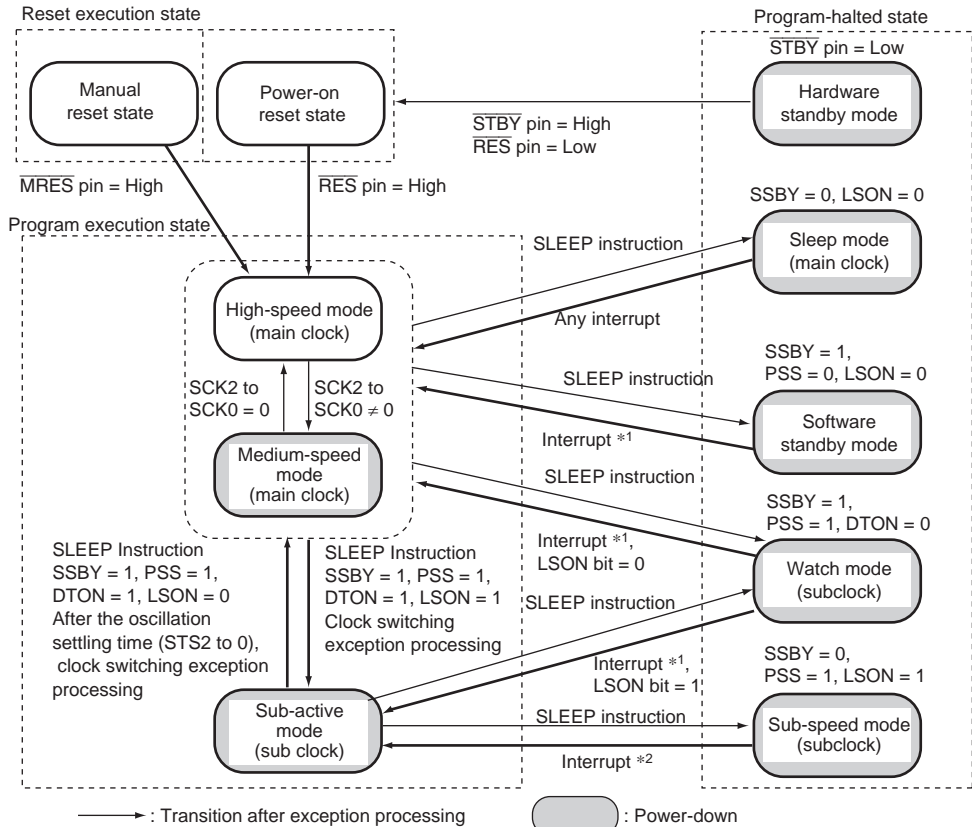
Function		High-Speed	Medium-Speed	Sleep	Module Stop	Watch	Subactive	Subsleep	Software Standby	Hardware Standby
System clock pulse generator		Functioning	Functioning	Functioning	Functioning	Halted	Halted	Halted	Halted	Halted
Subclock pulse generator		Functioning/halted	Functioning/halted	Functioning/halted	Functioning/halted	Functioning	Functioning	Functioning	Functioning/halted	Halted
CPU	Instructions	Functioning	Medium-speed operation	Halted	Functioning	Halted	Subclock operation	Halted	Halted	Halted
	Registers			Retained		Retained		Retained	Retained	Undefined
RAM		Functioning	Functioning	Functioning	Functioning	Retained	Functioning	Retained	Retained	Retained
I/O		Functioning	Functioning	Functioning	Functioning	Retained	Functioning	Functioning	Halted	High impedance
External interrupts	NMI IRQ0 to IRQ4, IRQ7	Functioning	Functioning	Functioning	Functioning	Functioning	Functioning	Functioning	Functioning	Halted
Peripheral functions	DMAC	Functioning	Medium-speed operation	Functioning	Halted (retained)	Halted (retained)	Halted (retained)	Halted (retained)	Halted (retained)	Halted (reset)
	WDT	Functioning	Functioning	Functioning	Functioning	Halted (retained)	Subclock operation	Subclock operation	Halted (retained)	Halted (reset)
RTC	Clock operation	Subclock operation	Subclock operation	Subclock operation	Halted (retained)	Subclock operation	Subclock operation	Subclock operation	Subclock functioning/halted	Halted (reset)
	Free-running timer operation	Functioning	Functioning	Functioning	Halted (retained)	Halted (retained)	Halted (retained)	Halted (retained)	Halted (retained)	Halted (reset)
TPU		Functioning	Functioning	Functioning	Halted (retained)	Halted (retained)	Halted (retained)	Halted (retained)	Halted (retained)	Halted (reset)
SCI										
A/D		Functioning	Functioning	Functioning	Halted (reset)	Halted (reset)	Halted (reset)	Halted (reset)	Halted (reset)	Halted (reset)
USB		Functioning	Function not guaranteed	Functioning	Halted (retained)	Function not guaranteed. Always select module stop mode.			Halted (retained)	Halted (reset)
	PLL circuit				Halted				Halted	

Notes: "Halted (retained)" means that internal register values are retained. The internal state is "operation suspended."

"Halted (reset)" means that internal register values and internal states are initialized.

In module stop mode, only modules for which a stop setting has been made are halted (reset or retained).





Notes: When a transition is made between modes by means of an interrupt, the transition cannot be made on interrupt source generation alone. Ensure that interrupt handling is performed after accepting the interrupt request.

From any state except hardware standby mode, a transition to the power-on reset state occurs when  $\overline{RES}$  is driven low. From any state except hardware standby mode and power-on reset, a transition to the manual reset state occurs when  $\overline{MRES}$  is driven low.

From any state, a transition to hardware standby mode occurs when  $\overline{STBY}$  is driven low.

Always select high-speed mode before making a transition to watch mode or subactive mode.

1. NMI and IRQ0 to IRQ4, IRQ7, RTC interrupt, and USB suspend/resume interrupt
2. NMI and IRQ0 to IRQ4, IRQ7, RTC interrupt, and WDT interrupt

**Figure 20.1 Mode Transition Diagram**

Table 20.2 Transition Conditions of Power-Down Modes

Pre-Transition State	Status of Control Bit at Transition				State after Transition Invoked by SLEEP Command	State after Transition Back from Power-Down Mode Invoked by Interrupt
	SSBY	PSS	LSON	DTON		
High-speed/ Medium-speed	0	×	0	×	Sleep	High-speed/Medium-speed
	0	×	1	×	—	—
	1	0	0	×	Software standby	High-speed/Medium-speed
	1	0	1	×	—	—
	1	1	0	0	Watch	High-speed
	1	1	1	0	Watch	Subactive
	1	1	0	1	—	—
	1	1	1	1	Subactive	—
Subactive	0	0	×	×	—	—
	0	1	0	×	—	—
	0	1	1	×	Sub sleep	Subactive
	1	0	×	×	—	—
	1	1	0	0	Watch	High-speed
	1	1	1	0	Watch	Subactive
	1	1	0	1	High-speed	—
	1	1	1	1	—	—

Legend:

×: Don't care

—: Do not set

## 20.1 Register Descriptions

The registers relating to the power down mode are shown below. For details on the low power control register (LPWRCR), refer to section 19.1.2, Low Power Control Register (LPWRCR). For details on the system clock control register (SCKCR), refer to section 19.1.1, System Clock Control Register (SCKCR).

- Standby control register (SBYCR)
- System clock control register (SCKCR)
- Low power control register (LPWRCR)
- Timer control/status register (TCSR\_1)
- Module stop control register A (MSTPCRA)
- Module stop control register B (MSTPCRB)
- Module stop control register C (MSTPCRC)
- Extended module stop register (EXMDLSTP)

### 20.1.1 Standby Control Register (SBYCR)

SBYCR performs software standby mode control.

Bit	Bit Name	Initial Value	R/W	Description
7	SSBY	0	R/W	<p>Software Standby</p> <p>This bit specifies the transition mode after executing the SLEEP instruction</p> <p>0: Shifts to sleep mode when the SLEEP instruction is executed in high-speed mode or medium-speed mode. Shifts to subsleep mode when the SLEEP instruction is executed in subactive mode.</p> <p>1: Shifts to software standby mode, subactive mode, or watch mode when the SLEEP instruction is executed in high-speed mode or medium-speed mode. Shifts to watch mode or high-speed mode when the SLEEP instruction is executed in subactive mode.</p> <p>This bit does not change when clearing software standby mode by using external interrupts and shifting to normal operation. 0 should be written to this bit for clearing.</p>

Bit	Bit Name	Initial Value	R/W	Description	
6	STS2	0	R/W	Standby Timer Select 2 to 0	
5	STS1	0	R/W	<p>These bits select the MCU wait time for clock stabilization when cancel software standby mode, watch mode, or subactive mode by an external interrupt. With a crystal oscillator (tables 20.3 and 20.4), select a wait time of <math>t_{OSC2}</math> ms (oscillation stabilization time) or more, depending on the operating frequency. With an external clock, there are no specific wait requirements. However, in the F-ZTAT version a standby time of 16 wait states cannot be used with an external clock. In this case, select a wait time of 100 <math>\mu</math>s or more.</p> <p>000: Standby time = 8192 states            001: Standby time = 16384 states            010: Standby time = 32768 states            011: Standby time = 65536 states            100: Standby time = 131072 states            101: Standby time = 262144 states            110: Standby time = 2048 states            111: Standby time = 16 states</p>	
4	STS0	0	R/W		
3	OPE	1	R/W		<p>Output Port Enable</p> <p>This bit selects whether address bus and bus control signals (<math>\overline{CS0}</math> to <math>\overline{CS7}</math>, <math>\overline{AS}</math>, <math>\overline{RD}</math>, <math>\overline{HWR}</math>, and <math>\overline{LWR}</math>) are brought to high impedance state or retained in software standby mode, watch mode, or direct transition.</p> <p>0: High impedance state            1: Retained</p>
2 to 0	—	All 0	—		<p>Reserved</p> <p>These bits are always read as 0, and cannot be modified.</p>

### 20.1.2 Timer Control/Status Register (TCSR\_1)

TCSR\_1 controls the operation in power-down mode transition.

Bit	Bit Name	Initial Value	R/W	Description
7 to 5	—	All 0	—	Reserved The write value should always be 0.
4	PSS	0	R/W	<p>Prescaler Select</p> <p>0: When the SLEEP instruction is executed in high-speed mode or medium-speed mode, operation shifts to sleep mode or software standby mode.</p> <p>1: When the SLEEP instruction is executed in high-speed mode or medium-speed mode, operation shifts to sleep mode, watch mode, or subactive mode.</p> <p>When the SLEEP instruction is executed in subactive mode, operation shifts to subsleep mode, watch mode, or high-speed mode</p> <p>TCSR_1 differs from other registers in being more difficult to write to. The procedures for writing to and reading this register are given below.</p> <p>Write:</p> <p>TCSR_1 must be written to by a word transfer instruction. The upper byte of the written word must contain H'A5 and the lower byte must contain the write data. (When the PSS bit is set to 1, the upper byte of the written word must contain H'A510.)</p> <p>Read:</p> <p>TCSR_1 is read by the same procedure as for the general registers.</p>
3 to 0	—	All 0	—	Reserved The write value should always be 0.

### 20.1.3 Module Stop Control Registers A to C (MSTPCRA to MSTPCRC)

MSTPCR, comprising three 8-bit readable/writable registers, performs module stop mode control. Setting a bit to 1, causes the corresponding module to enter module stop mode, while clearing the bit to 0 clears the module stop mode.

#### MSTPCRA

Bit	Bit Name	Initial Value	R/W	Module
7	MSTPA7	0	R/W	DMA controller (DMAC)
6	MSTPA6*	0	R/W	—
5	MSTPA5	1	R/W	16-bit timer pulse unit (TPU)
4	MSTPA4*	1	R/W	—
3	MSTPA3*	1	R/W	—
2	MSTPA2*	1	R/W	—
1	MSTPA1	1	R/W	A/D converter
0	MSTPA0*	1	R/W	—

#### MSTPCRB

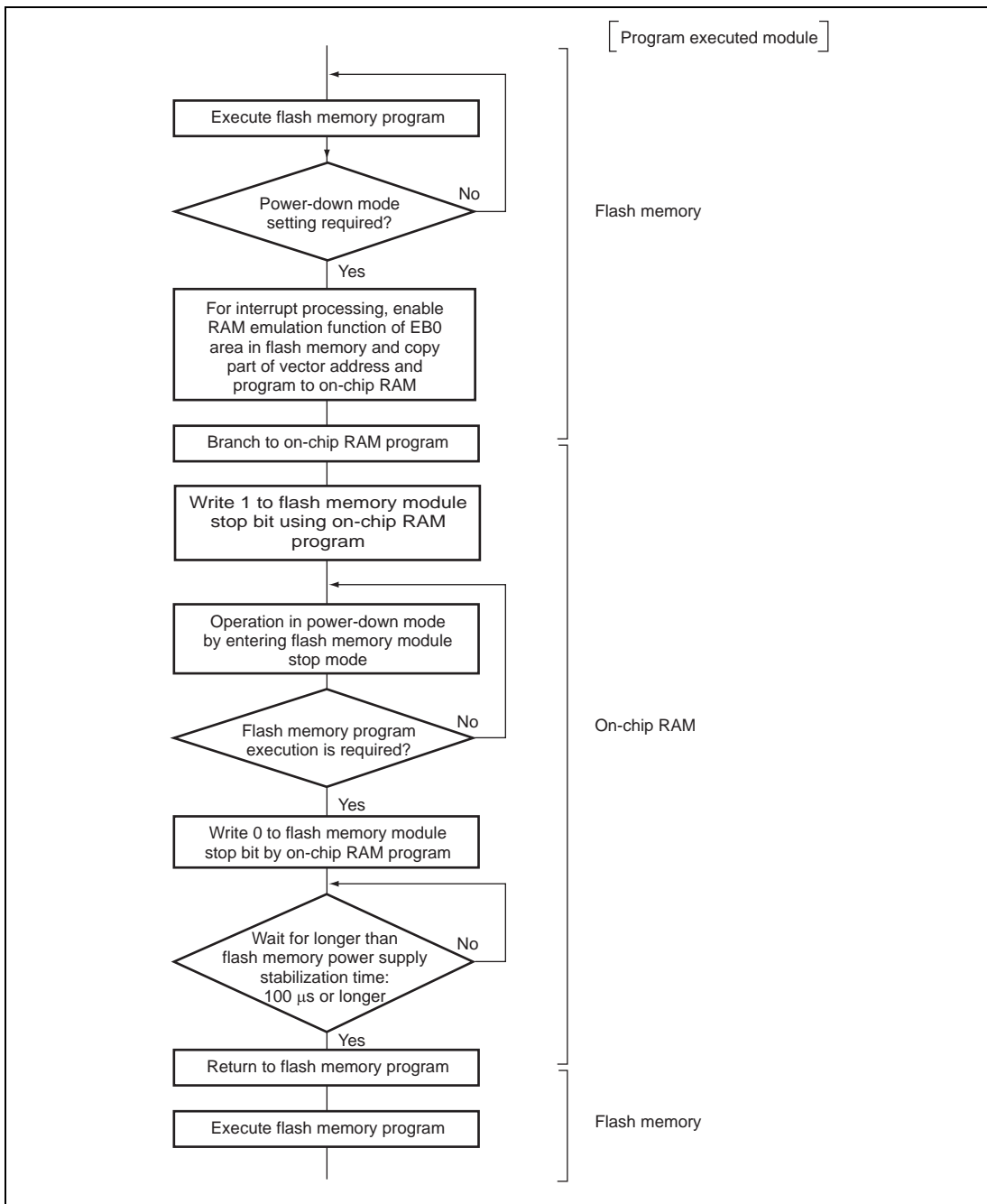
Bit	Bit Name	Initial Value	R/W	Module
7	MSTPB7	1	R/W	Serial communication interface 0 (SCI_0)
6	MSTPB6*	1	R/W	—
5	MSTPB5	1	R/W	Serial communication interface 2 (SCI_2)
4	MSTPB4*	1	R/W	—
3	MSTPB3*	1	R/W	—
2	MSTPB2*	1	R/W	—
1	MSTPB1*	1	R/W	—
0	MSTPB0	1	R/W	USB

## MSTPCRC

Bit	Bit Name	Initial Value	R/W	Module
7	MSTPC7*	1	R/W	—
6	MSTPC6*	1	R/W	—
5	MSTPC5*	1	R/W	—
4	MSTPC4*	1	R/W	—
3	MSTPC3*	1	R/W	—
2	MSTPC2*	1	R/W	—
1	MSTPC1	0	R/W	Flash Memory (This bit is reserved in the masked ROM version; setting is disabled.)
				Note: Setting of the flash memory module stop mode should be carried out while the programs in the on-chip RAM and external memory are executed. If the flash memory is stopped with the programming in the flash memory, the program after setting module stop mode stops and enters to the deadlock state. Figure 20.2 shows the example of using module stop mode.
0	MSTPC0*	1	R/W	—

Note: \* MSTPA6 are readable/writable bits with an initial value of 0 and should always be written with 1.

MSTPA4 to MSTPA2, MSTPA0, MSTPB6, MSTPB4 to MSTPB1, MSTPC7 to MSTPC2, MSTPC0 are readable/writable bits with an initial value of 1 and should always be written with 1.



**Figure 20.2 Example of Flash Memory Module Stop Mode Usage**



### 20.1.4 Extended Module Stop Register (EXMDLSTP)

EXMDLSTP controls the clock supply of the RTC and USB, performs module stop mode control. Setting a bit to 1, causes the corresponding module to enter module stop mode, while clearing the bit to 0 clears the module stop mode.

Bit	Bit Name	Initial Value	R/W	Module
7 to 2	—	Undefined	—	Reserved Read is undefined. These bits should not to be modified.
1	RTCSTOP	0	R/W	RTC
0	USBSTOP1	0	R/W	USB

## 20.2 Medium-Speed Mode

When the SCK2 to SCK0 bits in SCKCR are set to 1, the operating mode changes to medium-speed mode as soon as the current bus cycle ends. In medium-speed mode, the CPU operates on the operating clock ( $\phi/2$ ,  $\phi/4$ ,  $\phi/8$ ,  $\phi/16$ , or  $\phi/32$ ) specified by the SCK2 to SCK0 bits. The bus masters other than the CPU (DMAC) also operate in medium-speed mode. On-chip supporting modules other than the bus masters always operate on the high-speed clock ( $\phi$ ).

In medium-speed mode, a bus access is executed in the specified number of states with respect to the bus master operating clock. For example, if  $\phi/4$  is selected as the operating clock, on-chip memory is accessed in 4 states, and internal I/O registers in 8 states.

Medium-speed mode is cleared by clearing all of bits SCK2 to SCK0 to 0. A transition is made to high-speed mode and medium-speed mode is cleared at the end of the current bus cycle.

If a SLEEP instruction is executed when the SSBY bit in SBYCR, the LSON bit in LPWRCR are cleared to 0, a transition is made to sleep mode. When sleep mode is cleared by an interrupt, medium-speed mode is restored.

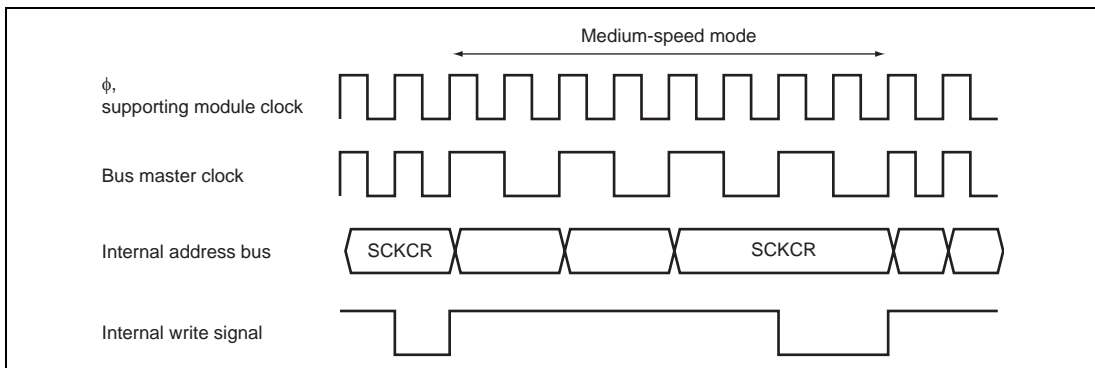
When the SLEEP instruction is executed with the SSBY bit = 1 and the LSON bit, and the PSS bit in TCSR\_1 are cleared to 0, operation shifts to the software standby mode. When software standby mode is cleared by an external interrupt, medium-speed mode is restored.

When the  $\overline{\text{RES}}$  or  $\overline{\text{MRES}}^*$  pin is set low and medium-speed mode is cancelled, operation shifts to the reset state. The same applies in the case of a reset caused by overflow of the watchdog timer.

When the  $\overline{\text{STBY}}$  pin is driven low, a transition is made to hardware standby mode.

Figure 20.3 shows the timing for transition to and clearance of medium-speed mode.

Note: \* Supported only by the H8S/2218 Group.



**Figure 20.3 Medium-Speed Mode Transition and Clearance Timing**

## 20.3 Sleep Mode

### 20.3.1 Transition to Sleep Mode

When the SLEEP instruction is executed when the SSBY bit in SBYCR and the LSON bit in LPWRCR are cleared to 0, the CPU enters the sleep mode. In sleep mode, CPU operation stops but the contents of the CPU's internal registers are retained. Other supporting modules do not stop.

### 20.3.2 Exiting Sleep Mode

Sleep mode is exited by any interrupt, or signals at the  $\overline{\text{RES}}$ ,  $\overline{\text{MRES}}^*$ , or  $\overline{\text{STBY}}$  pin.

- **Exiting Sleep Mode by Interrupts**  
When an interrupt occurs, sleep mode is exited and interrupt exception processing starts. Sleep mode is not exited if the interrupt is disabled, or interrupts other than NMI are masked by the CPU.
- **Exiting Sleep Mode by  $\overline{\text{RES}}$  or  $\overline{\text{MRES}}^*$  Pin**  
Setting the  $\overline{\text{RES}}$  or  $\overline{\text{MRES}}^*$  pin level Low selects the reset state. After the stipulated reset input duration, driving the  $\overline{\text{RES}}$  or  $\overline{\text{MRES}}^*$  pin High starts the CPU performing reset exception processing.
- **Exiting Sleep Mode by  $\overline{\text{STBY}}$  Pin**  
When the  $\overline{\text{STBY}}$  pin level is driven Low, a transition is made to hardware standby mode.

Note: \* Supported only by the H8S/2218 Group.

## 20.4 Software Standby Mode

### 20.4.1 Transition to Software Standby Mode

A transition is made to software standby mode when the SLEEP instruction is executed when the SSBY bit in SBYCR is set to 1 and the LSON bit in LPWRCR and the PSS bit in TCSR\_1 are cleared to 0. In this mode, the CPU, on-chip supporting modules, and oscillator all stop. However, the contents of the CPU's internal registers, RAM data, and the states of on-chip supporting modules other than the A/D converter, and the states of I/O ports, are retained. In this mode the oscillator stops, and therefore power dissipation is significantly reduced.

### 20.4.2 Clearing Software Standby Mode

Software standby mode is cleared by an external interrupt (NMI pin,  $\overline{\text{IRQ7}}$  pin, or  $\overline{\text{IRQ0}}$  to  $\overline{\text{IRQ4}}$  pins), RTC interrupt ( $\overline{\text{IRQ5}}$  signal), or USB suspend/resume interrupt ( $\overline{\text{IRQ6}}$  signal), or by means of the  $\overline{\text{RES}}$  pin,  $\overline{\text{MRES}}$  pin\*, or  $\overline{\text{STBY}}$  pin.

- Clearing with an interrupt  
When an NMI or  $\overline{\text{IRQ0}}$  to  $\overline{\text{IRQ7}}$  interrupt request signal is input, clock oscillation starts, and after the elapse of the time set in bits STS2 to STS0 in SBYCR, stable clocks are supplied to the entire chip, software standby mode is cleared, and interrupt exception handling is started. When clearing software standby mode with an  $\overline{\text{IRQ0}}$  to  $\overline{\text{IRQ7}}$  interrupt, set the corresponding enable bit to 1 and ensure that no interrupt with a higher priority than interrupts  $\overline{\text{IRQ0}}$  to  $\overline{\text{IRQ5}}$  is generated. Software standby mode cannot be cleared if the interrupt has been masked on the CPU side.
- Clearing with the  $\overline{\text{RES}}$  or  $\overline{\text{MRES}}$ \* pin  
When the  $\overline{\text{RES}}$  or  $\overline{\text{MRES}}$ \* pin is driven low, clock oscillation is started. At the same time as clock oscillation starts, clocks are supplied to the entire chip. Note that the  $\overline{\text{RES}}$  or  $\overline{\text{MRES}}$ \* pin must be held low until clock oscillation stabilizes. When the  $\overline{\text{RES}}$  or  $\overline{\text{MRES}}$ \* pin goes high, the CPU begins reset exception handling.
- Clearing with the  $\overline{\text{STBY}}$  pin  
When the  $\overline{\text{STBY}}$  pin is driven low, a transition is made to hardware standby mode.

Note: \* Supported only by the H8S/2218 Group.

### 20.4.3 Setting Oscillation Stabilization Time after Clearing Software Standby Mode

Bits STS2 to STS0 in SBYCR should be set as described below.

- Using a Crystal Oscillator:  
Set bits STS2 to STS0 so that the standby time is at least  $t_{OSC2}$  ms (the oscillation stabilization time).  
Table 20.3 shows the standby times for different operating frequencies and settings of bits STS2 to STS0.
- Using an External Clock  
Set bits STS2 to STS0 as any value. Usually, minimum value is recommended. A standby time of 100  $\mu$ s or longer (flash memory power supply stabilization time) should be used in the F-ZTAT version.

**Table 20.3 Oscillation Stabilization Time Settings**

STS2	STS1	STS0	Standby Time	24MHz	20MHz	16MHz	13MHz	10MHz	8MHz	6MHz	4MHz	2MHz	Unit
0	0	0	8192 states	0.34	0.41	0.51	0.63	0.82	1.0	1.4	2.0	4.1	ms
		1	16384 states	0.68	0.82	1.0	1.3	1.6	2.0	2.7	4.1	8.2	
	1	0	32768 states	1.4	1.6	2.0	2.5	3.3	4.1	5.5	8.2	16.4	
		1	65536 states	2.7	3.3	4.1	5.0	6.6	8.2	10.9	16.4	32.8	
1	0	0	131072 states	5.5	6.6	8.2	10.1	13.1	16.4	21.8	32.8	65.5	$\mu$ s
		1	262144 states	10.9	13.1	16.4	20.2	26.2	32.8	43.7	65.5	131.1	
	1	0	2048 states	0.09	0.10	0.13	0.16	0.20	0.26	0.34	0.51	1.0	
		1	16 states	0.67	0.80	1.0	1.2	1.6	2.0	2.7	4.0	8.0	

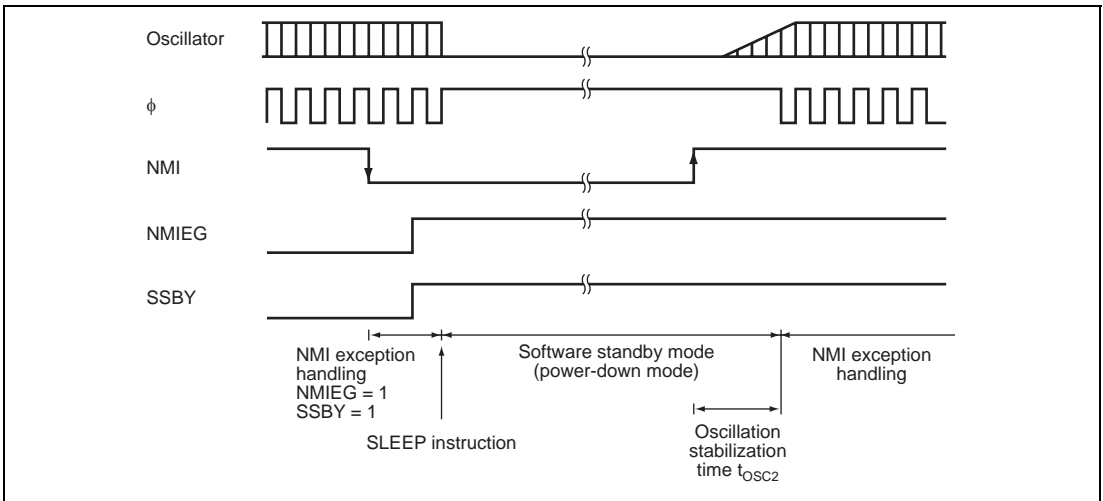
█: Recommended time setting (For conditions, see  $t_{OSC2}$  in table 22.4.)

### 20.4.4 Software Standby Mode Application Example

Figure 20.4 shows an example in which a transition is made to software standby mode at the falling edge on the NMI pin, and software standby mode is cleared at the rising edge on the NMI pin.

In this example, an NMI interrupt is accepted with the NMIEG bit in SYSCR cleared to 0 (falling edge specification), then the NMIEG bit is set to 1 (rising edge specification), the SSBY bit is set to 1, and a SLEEP instruction is executed, causing a transition to software standby mode.

Software standby mode is then cleared at the rising edge on the NMI pin.



**Figure 20.4 Software Standby Mode Application Example**

## 20.5 Hardware Standby Mode

### 20.5.1 Transition to Hardware Standby Mode

When the  $\overline{\text{STBY}}$  pin is driven low, a transition is made to hardware standby mode from any mode.

In hardware standby mode, all functions enter the reset state and stop operation, resulting in a significant reduction in power dissipation. As long as the prescribed voltage is supplied, on-chip RAM data is retained. I/O ports are set to the high-impedance state.

In order to retain on-chip RAM data, the RAME bit in SYSCR should be cleared to 0 before driving the  $\overline{\text{STBY}}$  pin low.

Do not change the state of the mode pins (MD2 to MD0) while this LSI is in hardware standby mode.

### 20.5.2 Clearing Hardware Standby Mode

Hardware standby mode is cleared by means of the  $\overline{\text{STBY}}$  pin and the  $\overline{\text{RES}}$  pin. When the  $\overline{\text{STBY}}$  pin is driven high while the  $\overline{\text{RES}}$  pin is low, the reset state is set and clock oscillation is started. Ensure that the  $\overline{\text{RES}}$  pin is held low until the clock oscillator stabilizes (at least  $t_{\text{osc1}}$ —the oscillation stabilization time—when using a crystal oscillator). When the  $\overline{\text{RES}}$  pin is subsequently driven high, a transition is made to the program execution state via the reset exception handling state.

### 20.5.3 Hardware Standby Mode Timing

Figure 20.5 shows an example of hardware standby mode timing.

When the  $\overline{\text{STBY}}$  pin is driven low after the  $\overline{\text{RES}}$  pin has been driven low, a transition is made to hardware standby mode. Hardware standby mode is cleared by driving the  $\overline{\text{STBY}}$  pin high, waiting for the oscillation stabilization time, then changing the  $\overline{\text{RES}}$  pin from low to high.

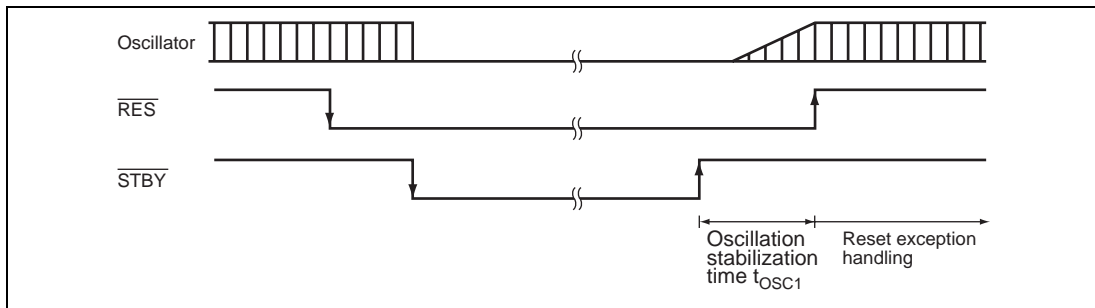


Figure 20.5 Hardware Standby Mode Timing (Example)

### 20.5.4 Hardware Standby Mode Timings

#### Timing of Transition to Hardware Standby Mode:

1. To retain RAM contents with the RAME bit set to 1 in SYSCR

Drive the  $\overline{\text{RES}}$  signal low at least 10 states before the  $\overline{\text{STBY}}$  signal goes low, as shown in figure 20.6. After  $\overline{\text{STBY}}$  has gone low,  $\overline{\text{RES}}$  has to wait for at least 0 ns before becoming high.

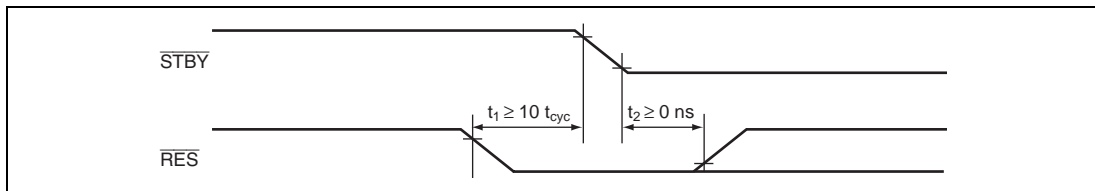


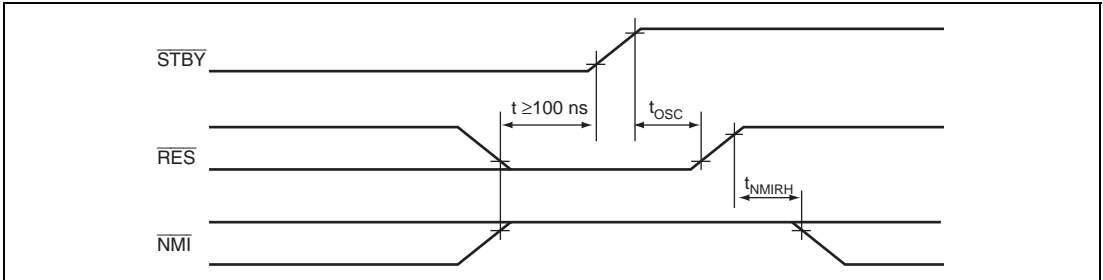
Figure 20.6 Timing of Transition to Hardware Standby Mode

2. To retain RAM contents with the RAME bit cleared to 0 in SYSCR, or when RAM contents do not need to be retained

$\overline{\text{RES}}$  does not have to be driven low as in the above case.

### Timing of Recovery from Hardware Standby Mode:

Drive the  $\overline{\text{RES}}$  signal low approximately 100 ns or more before  $\overline{\text{STBY}}$  goes high to execute a power-on reset.



**Figure 20.7 Timing of Recovery from Hardware Standby Mode**

## 20.6 Module Stop Mode

Module stop mode can be set for individual on-chip supporting modules.

When the corresponding MSTP bit in MSTPCR is set to 1, module operation stops at the end of the bus cycle and a transition is made to module stop mode. The CPU continues operating independently.

When the corresponding MSTP bit is cleared to 0, module stop mode is cleared and the module starts operating at the end of the bus cycle. In module stop mode, the internal states of modules other than the A/D converter are retained.

After reset clearance, all modules other than DMAC and flash memory are in module stop mode.

When an on-chip supporting module is in module stop mode, read/write access to its registers is disabled.

When a transition is made to sleep mode with all modules stopped, the bus controller and I/O ports also stop operating, enabling current dissipation to be further reduced.

## 20.7 Watch Mode

### 20.7.1 Transition to Watch Mode

CPU operation makes a transition to watch mode when the SLEEP instruction is executed in high-speed mode or subactive mode with SBYCR SSBY=1, LPWRCR DTON = 0, and TCSR\_1 PSS = 1.

In watch mode, the CPU is stopped and peripheral modules other than RTC are also stopped. The contents of the CPU's internal registers, the data in internal RAM, and the statuses of the internal peripheral modules (excluding the A/D converter) and I/O ports are retained. To make a transition to watch mode, bits SCK2 to SCK0 in SCKCR must be set to 0.

### 20.7.2 Exiting Watch Mode

Watch mode is exited by any interrupt (WOVI interrupt, NMI pin, or  $\overline{\text{IRQ0}}$ , to  $\overline{\text{IRQ7}}$ ), or signals at the  $\overline{\text{RES}}$ ,  $\overline{\text{MRES}}^*$ , or  $\overline{\text{STBY}}$  pin.

- Exiting Watch Mode by Interrupts

When an interrupt occurs, watch mode is exited and a transition is made to high-speed mode or medium-speed mode when the LPWRCR LSON bit = 0 or to subactive mode when the LSON bit = 1. When a transition is made to high-speed mode, a stable clock is supplied to all LSI circuits and interrupt exception processing starts after the time set in SBYCR STS2 to STS0 has elapsed. In case of IRQ0, to IRQ7 interrupts, no transition is made from watch mode if the corresponding enable bit/pin function switching bit has been cleared to 0, and, in the case of interrupts from the internal peripheral modules, the interrupt enable register has been set to disable the reception of that interrupt, or is masked by the CPU.

See section 20.4.3, Setting Oscillation Stabilization Time after Clearing Software Standby Mode, for how to set the oscillation settling time when making a transition from watch mode to high-speed mode.

- Exiting Watch Mode by  $\overline{\text{RES}}$  or  $\overline{\text{MRES}}^*$  pin

For exiting watch mode by the  $\overline{\text{RES}}$  or  $\overline{\text{MRES}}^*$  pin, see section 20.4.2, Clearing Software Standby Mode.

- Exiting Watch Mode by  $\overline{\text{STBY}}$  pin

When the  $\overline{\text{STBY}}$  pin level is driven low, a transition is made to hardware standby mode.

Note: \* Supported only by the H8S/2218 Group.



## 20.8 Subsleep Mode

### 20.8.1 Transition to Sleep Mode

When the SLEEP instruction is executed with the SBYCR SSBY bit = 0, LPWRCR LSON bit = 1, and TCSR\_1 PSS bit = 1, CPU operation shifts to subsleep mode.

In subsleep mode, the CPU is stopped. Peripheral modules other WDT and RTC are also stopped. The contents of the CPU's internal registers, the data in internal RAM, and the statuses of the internal peripheral modules (excluding the A/D converter) and I/O ports are retained.

### 20.8.2 Exiting Subsleep Mode

Subsleep mode is exited by an interrupt (interrupts from internal peripheral modules, NMI pin, or  $\overline{\text{IRQ0}}$ , to  $\overline{\text{IRQ7}}$ ), or signals at the  $\overline{\text{RES}}$ ,  $\overline{\text{MRES}}$ \*, or  $\overline{\text{STBY}}$  pin.

- Exiting Subsleep Mode by Interrupts

When an interrupt occurs, subsleep mode is exited and interrupt exception processing starts.

In case of  $\overline{\text{IRQ0}}$ , to  $\overline{\text{IRQ7}}$  interrupts, subsleep mode is not cancelled if the corresponding enable bit/pin function switching bit has been cleared to 0, and, in the case of interrupts from the internal peripheral modules, the interrupt enable register has been set to disable the reception of that interrupt, or is masked by the CPU.

- Exiting Subsleep Mode by  $\overline{\text{RES}}$  or  $\overline{\text{MRES}}$ \* pin

For exiting subsleep mode by the  $\overline{\text{RES}}$  or  $\overline{\text{MRES}}$ \* pin, see section 20.4.2, Clearing Software Standby Mode.

- Exiting Subsleep Mode by  $\overline{\text{STBY}}$  Pin

When the  $\overline{\text{STBY}}$  pin level is driven low, a transition is made to hardware standby mode.

Note: \* Supported only by the H8S/2218 Group.

## 20.9 Subactive Mode

### 20.9.1 Transition to Subactive Mode

When the SLEEP instruction is executed in high-speed mode with the SBYCR SSBY bit = 1, LPWRCR DTON bit = 1, LSON bit = 1, and TCSR\_1 PSS bit = 1, CPU operation shifts to subactive mode. When an interrupt occurs in watch mode, and if the LSON bit of LPWRCR is 1, a transition is made to subactive mode. And if an interrupt occurs in subsleep mode, a transition is made to subactive mode.

In subactive mode, the CPU operates at low speed on the subclock, and the program is executed step by step. Peripheral modules other than WDT and RTC are also stopped.

When operating the CPU in subactive mode, the SCKCR SCK2 to SCK0 bits must be set to 0.

### 20.9.2 Exiting Subactive Mode

Subactive mode is exited by the SLEEP instruction or the  $\overline{\text{RES}}$ ,  $\overline{\text{MRES}}^*$ , or  $\overline{\text{STBY}}$  pin.

- **Exiting Subactive Mode by SLEEP Instruction**  
When the SLEEP instruction is executed with the SBYCR SSBY bit = 1, LPWRCR DTON bit = 0, and TCSR\_1 PSS bit = 1, the CPU exits subactive mode and a transition is made to watch mode. When the SLEEP instruction is executed with the SBYCR SSBY bit = 0, LPWRCR LSON bit = 1, and TCSR\_1 PSS bit = 1, a transition is made to subsleep mode. Finally, when the SLEEP instruction is executed with the SBYCR SSBY bit = 1, LPWRCR DTON bit = 1, LSON bit = 0, and TCSR\_1 PSS bit = 1, a direct transition is made to high-speed mode (SCK0 to SCK2 all 0).
- **Exiting Subactive Mode by  $\overline{\text{RES}}$  or  $\overline{\text{MRES}}^*$  pin**  
For exiting subactive mode by the  $\overline{\text{RES}}$  or  $\overline{\text{MRES}}^*$  pin, see section 20.4.2, Clearing Software Standby Mode.
- **Exiting Subactive Mode by  $\overline{\text{STBY}}$  Pin**  
When the  $\overline{\text{STBY}}$  pin level is driven low, a transition is made to hardware standby mode.

Note: \* Supported only by the H8S/2218 Group.

## 20.10 Direct Transitions

There are three modes, high-speed, medium-speed, and subactive, in which the CPU executes programs. When a direct transition is made, there is no interruption of program execution when shifting between high-speed and subactive modes. Direct transitions are enabled by setting the LPWRCR DTON bit to 1, then executing the SLEEP instruction. After a transition, direct transition interrupt exception processing starts.

### 20.10.1 Direct Transitions from High-Speed Mode to Subactive Mode

Execute the SLEEP instruction in high-speed mode when the SBYCR SSBY bit = 1, LPWRCR LSON bit = 1, and DTON bit = 1, and TSCR\_1 PSS bit = 1 to make a transition to subactive mode.

### 20.10.2 Direct Transitions from Subactive Mode to High-Speed Mode

Execute the SLEEP instruction in subactive mode when the SBYCR SSBY bit = 1, LPWRCR LSON bit = 0, and DTON bit = 1, and TSCR\_1 PSS bit = 1 to make a direct transition to high-speed mode after the time set in SBYCR STS2 to STS0 has elapsed.

## 20.11 $\phi$ Clock Output Disabling Function

Output of the  $\phi$  clock can be controlled by means of the PSTOP bit in SCKCR, and DDR for the corresponding port. When the PSTOP bit is set to 1, the  $\phi$  clock stops at the end of the bus cycle, and  $\phi$  output goes high.  $\phi$  clock output is enabled when the PSTOP bit is cleared to 0. When DDR for the corresponding port is cleared to 0,  $\phi$  clock output is disabled and input port mode is set. Table 20.4 shows the state of the  $\phi$  pin in each processing state.

**Table 20.4  $\phi$  Pin State in Each Processing State**

Register Settings		High-Speed Mode, Medium-Speed Mode, Subactive Mode	Sleep Mode, Subsleep Mode	Software Standby Mode, Watch Mode, Direct Transition	Hardware Standby Mode
DDR	PSSTOP				
0	×	High impedance	High impedance	High impedance	High impedance
1	0	$\phi$ output	$\phi$ output	Fixed high	High impedance
1	1	Fixed high	Fixed high	Fixed high	High impedance

Legend:

×: Don't care

## 20.12 Usage Notes

### 20.12.1 I/O Port Status

In software standby mode or watch mode, I/O port states are retained. In addition, if the OPE bit is set to 1, the address bus and bus control signal output are retained. Therefore, there is no reduction in current dissipation for the output current when a high-level signal is output.

### 20.12.2 Current Dissipation during Oscillation Stabilization Wait Period

Current dissipation increases during the oscillation stabilization wait period.

### 20.12.3 Flash Memory Module Stop

Setting of the flash memory module stop mode should be carried out while the programs in the on-chip RAM and external memory are executed. For details, see section 20.1.3, Module Stop Control Registers A to C (MSTPCRA to MSTPCRC).

### 20.12.4 DMAC Module Stop

Depending on the operating status of the DMAC, the MSTPA7 bit may not be set to 1. Setting of the DMAC module stop mode should be carried out only when the DMAC is not activated.

For details, section 7, DMA Controller (DMAC).

### 20.12.5 On-Chip Peripheral Module Interrupt

- Module stop mode

Relevant interrupt operations cannot be performed in module stop mode. Consequently, if module stop mode is entered when an interrupt has been requested, it will not be possible to clear the CPU interrupt source or DMAC activation source. Interrupts should therefore be disabled before setting module stop mode.

- Subactive Mode/Watch Mode

On-chip peripheral modules (DMAC and TPU) that stop operation in subactive mode cannot clear interrupts in subactive mode. Therefore, if subactive mode is entered when an interrupt is requested, CPU interrupt factors cannot be cleared.

Interrupts should therefore be cleared before executing the SLEEP instruction and entering subactive or watch mode.

### **20.12.6 Entering Subactive/Watch Mode and DMAC and DTC Module Stop**

To enter subactive or watch mode, set DMAC to module stop (write 1 to the MSTPA7 bit) and reading the MSTPA7 bit as 1 before transiting mode. After transiting from subactive mode to active mode, clear module stop.

When a DMAC activation source is generated in subactive mode, the DMAC is activated when module stop is cleared following the transition to active mode.

### **20.12.7 Writing to MSTPCR**

MSTPCR should only be written to by the CPU.



---

## Section 21 List of Registers

The register list gives information on the on-chip I/O register addresses, how the register bits are configured, and the register states in each operating mode. The information is given as shown below.

### 1. Register Addresses (address order)

- Registers are listed from the lower allocation addresses.
- Registers are classified by functional modules.
- The access size is indicated.

### 2. Register Bits

- Bit configurations of the registers are described in the same order as the Register Addresses (address order) above.
- Reserved bits are indicated by “—” in the bit name column.
- The bit number in the bit-name column indicates that the whole register is allocated as a counter or for holding data.
- 16-bit or 24-bit registers are indicated from the bit on the MSB side.

### 3. Register States in Each Operating Mode

- Register states are described in the same order as the Register Addresses (address order) above.
- The register states described here are for the basic operating modes. If there is a specific reset for an on-chip peripheral module, refer to the section on that on-chip peripheral module.

## 21.1 Register Addresses (Address Order)

The data bus width indicates the numbers of bits by which the register is accessed.

The number of access states indicates the number of states based on the specified reference clock.

Register Name	Abbreviation	Number of Bits	Address	Data Bus Width	Number of Access States	Module
USB reserved area	—	—	H'C00000 to H'C0007F	—	—	USB
USB control register	UCTLR	8	H'C00080	8	3	
USB test register A	UTSTRA	8	H'C00081	8	3	
USB DMAC transfer request register	UDMAR	8	H'C00082	8	3	
USB device resume register	UDRR	8	H'C00083	8	3	
USB trigger register 0	UTRG0	8	H'C00084	8	3	
USB FIFO clear register 0	UFCLR0	8	H'C00086	8	3	
USB endpoint stall register 0	UESTL0	8	H'C00088	8	3	
USB endpoint stall register 1	UESTL1	8	H'C00089	8	3	
USB endpoint data register 0s	UEDR0s	8	H'C00090 to H'C00093	8	3	
USB endpoint data register 0i	UEDR0i	8	H'C00094 to H'C00097	8	3	
USB endpoint data register 0o	UEDR0o	8	H'C00098 to H'C0009B	8	3	
USB endpoint data register 3	UEDR3	8	H'C0009C to H'C0009F	8	3	
USB endpoint data register 1	UEDR1	8	H'C000A0 to H'C000A3	8	3	
USB endpoint data register 2	UEDR2	8	H'C000A4 to H'C000A7	8	3	



Register Name	Abbreviation	Number of Bits	Address	Data Bus Width	Number of Access States	Module
USB endpoint receive data size register 0o	UESZ0o	8	H'C000BC	8	3	USB
USB endpoint receive data size register 2	UESZ2	8	H'C000BD	8	3	
USB interrupt flag register 0	UIFR0	8	H'C000C0	8	3	
USB interrupt flag register 1	UIFR1	8	H'C000C1	8	3	
USB interrupt flag register 3	UIFR3	8	H'C000C3	8	3	
USB interrupt enable register 0	UIER0	8	H'C000C4	8	3	
USB interrupt enable register 1	UIER1	8	H'C000C5	8	3	
USB interrupt enable register 3	UIER3	8	H'C000C7	8	3	
USB interrupt selection register 0	UISR0	8	H'C000C8	8	3	
USB interrupt selection register 1	UISR1	8	H'C000C9	8	3	
USB interrupt selection register 3	UISR3	8	H'C000CB	8	3	
USB data status register	UDSR	8	H'C000CC	8	3	
USB configuration value register	UCVR	8	H'C000CF	8	3	
USB test register 0	UTSTR0	8	H'C000F0	8	3	
USB test register 1	UTSTR1	8	H'C000F1	8	3	
USB test register 2	UTSTR2	8	H'C000F2	8	3	
USB test register B	UTSTRB	8	H'C000FB	8	3	
USB test register C	UTSTRC	8	H'C000FC	8	3	
USB test register D	UTSTRD	8	H'C000FD	8	3	
USB test register E	UTSTRE	8	H'C000FE	8	3	
USB test register F	UTSTRF	8	H'C000FF	8	3	
USB reserved area	—	—	H'C00100 to H'DFFFFFF	—	—	
Serial control register X	SCRX	8	H'FDB4	8	2	FLASH

## Section 21 List of Registers

Register Name	Abbreviation	Number of Bits	Address	Data Bus Width	Number of Access States	Module
Standby control register	SBYCR	8	H'FDE4	8	2	SYSTEM
System control register	SYSCR	8	H'FDE5	8	2	
System clock control register	SCKCR	8	H'FDE6	8	2	
Mode control register	MDCR	8	H'FDE7	8	2	
Module stop control register A	MSTPCRA	8	H'FDE8	8	2	
Module stop control register B	MSTPCRB	8	H'FDE9	8	2	
Module stop control register C	MSTPCRC	8	H'FDEA	8	2	
Pin function control register	PFCR	8	H'FDEB	8	2	BSC
Low power control register	LPWRCR	8	H'FDEC	8	2	SYSTEM
Clock output control register	OUTCR	8	H'FDEF	8	2	PORT
Serial extended mode register A_0	SEMRA_0	8	H'FDF8	8	2	SCI_0
Serial extended mode register B_0	SEMRB_0	8	H'FDF9	8	2	
IRQ sense control register H	ISCRH	8	H'FE12	8	2	INT
IRQ sense control register L	ISCRH	8	H'FE13	8	2	
IRQ enable register	IER	8	H'FE14	8	2	
IRQ status register	ISR	8	H'FE15	8	2	
Port 1 data direction register	P1DDR	8	H'FE30	8	2	PORT
Port 3 data direction register	P3DDR	8	H'FE32	8	2	
Port 7 data direction register	P7DDR	8	H'FE36	8	2	
Port A data direction register	PADDR	8	H'FE39	8	2	
Port B data direction register	PBDDR	8	H'FE3A	8	2	
Port C data direction register	PCDDR	8	H'FE3B	8	2	
Port D data direction register	PDDDR	8	H'FE3C	8	2	
Port E data direction register	PEDDR	8	H'FE3D	8	2	
Port F data direction register	PFDDR	8	H'FE3E	8	2	
Port G data direction register	PGDDR	8	H'FE3F	8	2	
Port A pull-up MOS control register	PAPCR	8	H'FE40	8	2	
Port B pull-up MOS control register	PBPCR	8	H'FE41	8	2	
Port C pull-up MOS control register	PCPCR	8	H'FE42	8	2	
Port D pull-up MOS control register	PDPCR	8	H'FE43	8	2	
Port E pull-up MOS control register	PEPCR	8	H'FE44	8	2	
Port 3 open drain control register	P3ODR	8	H'FE46	8	2	
Port A open drain control register	PAODR	8	H'FE47	8	2	

Register Name	Abbreviation	Number of Bits	Address	Data Bus Width	Number of Access States	Module
Timer start register	TSTR	8	H'FEB0	16	2	TPU
Timer synchro register	TSYR	8	H'FEB1	16	2	
Interrupt priority register A	IPRA	8	H'FEC0	8	2	INT
Interrupt priority register B	IPRB	8	H'FEC1	8	2	
Interrupt priority register C	IPRC	8	H'FEC2	8	2	
Interrupt priority register D	IPRD	8	H'FEC3	8	2	
Interrupt priority register E	IPRE	8	H'FEC4	8	2	
Interrupt priority register F	IPRF	8	H'FEC5	8	2	
Interrupt priority register G	IPRG	8	H'FEC6	8	2	
Interrupt priority register J	IPRJ	8	H'FEC9	8	2	
Interrupt priority register K	IPRK	8	H'FECA	8	2	
Interrupt priority register M	IPRM	8	H'FECC	8	2	
Bus width control register	ABWCR	8	H'FED0	8	2	BSC
Access state control register	ASTCR	8	H'FED1	8	2	
Wait control register H	WCRH	8	H'FED2	8	2	
Wait control register L	WCRL	8	H'FED3	8	2	
Bus control register H	BCRH	8	H'FED4	8	2	
Bus control register L	BCRL	8	H'FED5	8	2	
RAM emulation register	RAMER	8	H'FEDB	8	2	FLASH
Memory address register 0A H	MAR0AH	16	H'FEE0	16	2	DMAC
Memory address register 0A L	MAR0AL	16	H'FEE2	16	2	
I/O address register 0A	IOAR0A	16	H'FEE4	16	2	
Transfer count register 0A	ETCR0A	16	H'FEE6	16	2	
Memory address register 0B H	MAR0BH	16	H'FEE8	16	2	
Memory address register 0B L	MAR0BL	16	H'FEEA	16	2	
I/O address register 0B	IOAR0B	16	H'FEEC	16	2	
Transfer count register 0B	ETCR0B	16	H'FEED	16	2	
Memory address register 1A H	MAR1AH	16	H'FEF0	16	2	
Memory address register 1A L	MAR1AL	16	H'FEF2	16	2	
I/O address register 1A	IOAR1A	16	H'FEF4	16	2	
Transfer count register 1A	ETCR1A	16	H'FEF6	16	2	
Memory address register 1B H	MAR1BH	16	H'FEF8	16	2	
Memory address register 1B L	MAR1BL	16	H'FEFA	16	2	

## Section 21 List of Registers

Register Name	Abbreviation	Number of Bits	Address	Data Bus Width	Number of Access States	Module
I/O address register 1B	IOAR1B	16	H'FEFC	16	2	DMAC
Transfer count register 1B	ETCR1B	16	H'FEFE	16	2	
Port 1 data register	P1DR	8	H'FF00	8	2	PORT
Port 3 data register	P3DR	8	H'FF02	8	2	
Port 7 data register	P7DR	8	H'FF06	8	2	
Port A data register	PADR	8	H'FF09	8	2	
Port B data register	PBDR	8	H'FF0A	8	2	
Port C data register	PCDR	8	H'FF0B	8	2	
Port D data register	PDDR	8	H'FF0C	8	2	
Port E data register	PEDR	8	H'FF0D	8	2	
Port F data register	PFDR	8	H'FF0E	8	2	
Port G data register	PGDR	8	H'FF0F	8	2	
Timer control register_0	TCR_0	8	H'FF10	16	2	TPU_0
Timer mode register_0	TMDR_0	8	H'FF11	16	2	
Timer I/O control register H_0	TIORH_0	8	H'FF12	16	2	
Timer I/O control register L_0	TIORL_0	8	H'FF13	16	2	
Timer interrupt enable register_0	TIER_0	8	H'FF14	16	2	
Timer status register_0	TSR_0	8	H'FF15	16	2	
Timer counter_0	TCNT_0	16	H'FF16	16	2	
Timer general register A_0	TGRA_0	16	H'FF18	16	2	
Timer general register B_0	TGRB_0	16	H'FF1A	16	2	
Timer general register C_0	TGRC_0	16	H'FF1C	16	2	
Timer general register D_0	TGRD_0	16	H'FF1E	16	2	
Timer control register_1	TCR_1	8	H'FF20	16	2	TPU_1
Timer mode register_1	TMDR_1	8	H'FF21	16	2	
Timer I/O control register_1	TIOR_1	8	H'FF22	16	2	
Timer interrupt enable register_1	TIER_1	8	H'FF24	16	2	
Timer status register_1	TSR_1	8	H'FF25	16	2	
Timer counter_1	TCNT_1	16	H'FF26	16	2	
Timer general register A_1	TGRA_1	16	H'FF28	16	2	
Timer general register B_1	TGRB_1	16	H'FF2A	16	2	

Register Name	Abbreviation	Number of Bits	Address	Data Bus Width	Number of Access States	Module
Timer control register_2	TCR_2	8	H'FF30	16	2	TPU_2
Timer mode register_2	TMDR_2	8	H'FF31	16	2	
Timer I/O control register 2	TIOR_2	8	H'FF32	16	2	
Timer interrupt enable register 2	TIER_2	8	H'FF34	16	2	
Timer status register_2	TSR_2	8	H'FF35	16	2	
Timer counter_2	TCNT_2	16	H'FF36	16	2	
Timer general register A_2	TGRA_2	16	H'FF38	16	2	
Timer general register B_2	TGRB_2	16	H'FF3A	16	2	
Extended module stop register	EXMDLSTP	8	H'FF40	8	2	SYSTEM
Second data register/ free running counter data register	RSECDR	8	H'FF48	8	2	RTC
Minute data register	RMINDR	8	H'FF49	8	2	
Hour data register	RHRDR	8	H'FF4A	8	2	
Day-of-week data register	RWKDR	8	H'FF4B	8	2	
RTC control register 1	RTCCR1	8	H'FF4C	8	2	
RTC control register 2	RTCCR2	8	H'FF4D	8	2	
Clock source select register	RTCCSR	8	H'FF4F	8	2	
DMA control register 0A	DMACR0A	8	H'FF62	16	2	DMAC
DMA control register 0B	DMACR0B	8	H'FF63	16	2	
DMA control register 1A	DMACR1A	8	H'FF64	16	2	
DMA control register 1B	DMACR1B	8	H'FF65	16	2	
DMA band control register	DMABCR	16	H'FF66	16	2	
Timer control/status register	TCSR	8	H'FF74	16	2	WDT
Timer counter	TCNT	8	H'FF74 (write)	16	2	
Timer counter	TCNT	8	H'FF75 (read)	16	2	
Reset control/status register	RSTCSR	8	H'FF76 (write)	16	2	
Reset control/status register	RSTCSR	8	H'FF77 (read)	16	2	

## Section 21 List of Registers

Register Name	Abbreviation	Number of Bits	Address	Data Bus Width	Number of Access States	Module
Serial mode register_0	SMR_0	8	H'FF78	8	2	SCI_0
Bit rate register_0	BRR_0	8	H'FF79	8	2	
Serial control register_0	SCR_0	8	H'FF7A	8	2	
Transmit data register_0	TDR_0	8	H'FF7B	8	2	
Serial status register_0	SSR_0	8	H'FF7C	8	2	
Receive data register_0	RDR_0	8	H'FF7D	8	2	
Smart card mode register_0	SCMR_0	8	H'FF7E	8	2	
Serial mode register_2	SMR_2	8	H'FF88	8	2	SCI_2
Bit rate register_2	BRR_2	8	H'FF89	8	2	
Serial control register_2	SCR_2	8	H'FF8A	8	2	
Transmit data register_2	TDR_2	8	H'FF8B	8	2	
Serial status register_2	SSR_2	8	H'FF8C	8	2	
Receive data register_2	RDR_2	8	H'FF8D	8	2	
Smart card mode register_2	SCMR_2	8	H'FF8E	8	2	
A/D data register AH	ADDRAH	8	H'FF90	8	2	A/D
A/D data register AL	ADDRAL	8	H'FF91	8	2	
A/D data register BH	ADDRBH	8	H'FF92	8	2	
A/D data register BL	ADDRBL	8	H'FF93	8	2	
A/D data register CH	ADDRCH	8	H'FF94	8	2	
A/D data register CL	ADDRCL	8	H'FF95	8	2	
A/D data register DH	ADDRDH	8	H'FF96	8	2	
A/D data register DL	ADDRDL	8	H'FF97	8	2	
A/D control/status register	ADCSR	8	H'FF98	8	2	
A/D control register	ADCR	8	H'FF99	8	2	
Timer control/status register	TCSR_1	8	H'FFA2	16	2	SYSTEM
Flash memory control register 1	FLMCR1	8	H'FFA8	8	2	FLASH
Flash memory control register 2	FLMCR2	8	H'FFA9	8	2	
Erase block register 1	EBR1	8	H'FFAA	8	2	
Erase block register 2	EBR2	8	H'FFAB	8	2	

Register Name	Abbreviation	Number of Bits	Address	Data Bus Width	Number of Access States	Module
Port 1 register	PORT1	8	H'FFB0	8	2	PORT
Port 3 register	PORT3	8	H'FFB2	8	2	
Port 4 register	PORT4	8	H'FFB3	8	2	
Port 7 register	PORT7	8	H'FFB6	8	2	
Port 9 register	PORT9	8	H'FFB8	8	2	
Port A register	PORTA	8	H'FFB9	8	2	
Port B register	PORTB	8	H'FFBA	8	2	
Port C register	PORTC	8	H'FFBB	8	2	
Port D register	PORTD	8	H'FFBC	8	2	
Port E register	PORTE	8	H'FFBD	8	2	
Port F register	PORTF	8	H'FFBE	8	2	
Port G register	PORTG	8	H'FFBF	8	2	

## 21.2 Register Bits

Register bit names of the on-chip peripheral modules are described below.

Each line covers eight bits, so 16-bit registers are shown as two lines and 32-bit registers as four lines.

Register Name	Bit 7	Bit 6	Bit 5	Bit 4	Bit 3	Bit 2	Bit 1	Bit 0	Module
UCTLR	—	USPNDE	UCKS3	UCKS2	UCKS1	UCKS0	UIFRST	UDCRST	USB
UTSTRA	—	—	—	—	—	—	—	—	
UDMAR	—	—	—	—	EP2T1	EP2T0	EP1T1	EP1T0	
UDRR	—	—	—	—	—	—	RWUPs	DVR	
UTRG0	—	—	EP2RDFN	EP1PKTE	EP3PKTE	EP0oRDFN	EP0iPKTE	EP0sRDFN	
UFCLR0	—	—	EP2CLR	EP1CLR	EP3CLR	EP0oCLR	EP0iCLR	—	
UESTL0	—	—	EP2STL	EP1STL	EP3STL	—	—	EP0STL	
UESTL1	SCME	—	—	—	—	—	—	—	
UEDR0s	D7	D6	D5	D4	D3	D2	D1	D0	
UEDR0i	D7	D6	D5	D4	D3	D2	D1	D0	
UEDR0o	D7	D6	D5	D4	D3	D2	D1	D0	
UEDR3	D7	D6	D5	D4	D3	D2	D1	D0	
UEDR1	D7	D6	D5	D4	D3	D2	D1	D0	
UEDR2	D7	D6	D5	D4	D3	D2	D1	D0	
UESZ0o	—	D6	D5	D4	D3	D2	D1	D0	
UESZ2	—	D6	D5	D4	D3	D2	D1	D0	
UIFR0	BRST	—	EP3TR	EP3TS	EP0oTS	EP0iTR	EP0iTS	SetupTS	
UIFR1	—	—	—	—	EP1ALL EMPTYs	EP2 READY	EP1TR	EP1 EMPTY	
UIFR3	CK48 READY	SOF	SETC	—	SPRSs	SPRSi	VBUSs	VBUSi	
UIER0	BRSTE	—	EP3TRE	EP3TSE	EP0oTSE	EP0iTRE	EP0iTSE	SetupTSE	
UIER1	—	—	—	—	—	EP2 READYE	EP1TRE	EP1 EMPTYE	
UIER3	CK48 READYE	SOFE	SETCE	—	—	SPRSiE	—	VBUSiE	
UISR0	BRSTS	—	EP3TRS	EP3TSS	EP0oTSS	EP0iTRS	EP0iTSS	SetupTSS	



Register Name	Bit 7	Bit 6	Bit 5	Bit 4	Bit 3	Bit 2	Bit 1	Bit 0	Module
UISR1	—	—	—	—	—	EP2 READY5	EP1TRS	EP1 EMPTY5	USB
UISR3	CK48 READY5	SOFS	SETCS	—	—	—	—	VBUSiS	
UDSR	—	—	—	—	—	EP1DE	EP3DE	EP0iDE	
UCVR	—	—	CNFV0	—	—	—	—	—	
UTSTR0	PTSTE	—	—	—	SUSPEND	OE	FSE0	VPO	
UTSTR1	VBUS	UBPM	—	—	—	RCV	VP	VM	
UTSTR2	—	—	—	—	—	—	—	—	
UTSTRB	—	—	—	—	—	—	—	—	
UTSTRC	—	—	—	—	—	—	—	—	
UTSTRD	—	—	—	—	—	—	—	—	
UTSTRE	—	—	—	—	—	—	—	—	
UTSTRF	—	—	—	—	—	—	—	—	
SCRX	—	—	—	—	FLSHE	—	—	—	FLASH
SBYCR	SSBY	STS2	STS1	STS0	OPE	—	—	—	SYSTEM
SYSCR	—	—	INTM1	INTM0	NMIEG	MRESE	—	RAME	
SCKCR	PSTOP	—	—	—	—	SCK2	SCK1	SCK0	
MDCR	—	—	—	—	FWE	MDS2	MDS1	MDS0	
MSTPCRA	MSTPA7	MSTPA6	MSTPA5	MSTPA4	MSTPA3	MSTPA2	MSTPA1	MSTPA0	
MSTPCRB	MSTPB7	MSTPB6	MSTPB5	MSTPB4	MSTPB3	MSTPB2	MSTPB1	MSTPB0	
MSTPCRC	MSTPC7	MSTPC6	MSTPC5	MSTPC4	MSTPC3	MSTPC2	MSTPC1	MSTPC0	
PF7CR	—	—	—	—	AE3	AE2	AE1	AE0	BSC
LPWRCR	DTON	LSON	NESEL	SUBSTP	RFCUT	—	STC1	STC0	SYSTEM
OUTCR	—	—	—	—	—	PF7OUT2	PF7OUT1	PF7OUT0	PORT
SEMRA_0	SSE	TCS2	TCS1	TCS0	ABCS	ACS2	ACS1	ACS0	SCI_0
SEMRB_0	ACS3	—	—	—	TIOCA2E	TIOCA1E	TIOCC0E	TIOCA0E	
ISCRH	IRQ7SCB	IRQ7SCA	IRQ6SCB	IRQ6SCA	IRQ5SCB	IRQ5SCA	IRQ4SCB	IRQ4SCA	INT
ISCR_L	IRQ3SCB	IRQ3SCA	IRQ2SCB	IRQ2SCA	IRQ1SCB	IRQ1SCA	IRQ0SCB	IRQ0SCA	
IER	IRQ7E	IRQ6E	IRQ5E	IRQ4E	IRQ3E	IRQ2E	IRQ1E	IRQ0E	
ISR	IRQ7F	IRQ6F	IRQ5F	IRQ4F	IRQ3F	IRQ2F	IRQ1F	IRQ0F	

## Section 21 List of Registers

Register									
Name	Bit 7	Bit 6	Bit 5	Bit 4	Bit 3	Bit 2	Bit 1	Bit 0	Module
P1DDR	P17DDR	P16DDR	P15DDR	P14DDR	P13DDR	P12DDR	P11DDR	P10DDR	PORT
P3DDR	—	P36DDR	—	—	—	P32DDR	P31DDR	P30DDR	
P7DDR	P77DDR	P76DDR	P75DDR	P74DDR	—	—	P71DDR	P70DDR	
PADDR	—	—	—	—	PA3DDR	PA2DDR	PA1DDR	PA0DDR	
PBDDR	PB7DDR	PB6DDR	PB5DDR	PB4DDR	PB3DDR	PB2DDR	PB1DDR	PB0DDR	
PCDDR	PC7DDR	PC6DDR	PC5DDR	PC4DDR	PC3DDR	PC2DDR	PC1DDR	PC0DDR	
PDDDR	PD7DDR	PD6DDR	PD5DDR	PD4DDR	PD3DDR	PD2DDR	PD1DDR	PD0DDR	
PEDDR	PE7DDR	PE6DDR	PE5DDR	PE4DDR	PE3DDR	PE2DDR	PE1DDR	PE0DDR	
PFDDR	PF7DDR	PF6DDR	PF5DDR	PF4DDR	PF3DDR	PF2DDR	PF1DDR	PF0DDR	
PGDDR	—	—	—	PG4DDR	PG3DDR	PG2DDR	PG1DDR	PG0DDR	
PAPCR	—	—	—	—	PA3PCR	PA2PCR	PA1PCR	PA0PCR	
PBPCR	PB7PCR	PB6PCR	PB5PCR	PB4PCR	PB3PCR	PB2PCR	PB1PCR	PB0PCR	
PCPCR	PC7PCR	PC6PCR	PC5PCR	PC4PCR	PC3PCR	PC2PCR	PC1PCR	PC0PCR	
PDPCR	PD7PCR	PD6PCR	PD5PCR	PD4PCR	PD3PCR	PD2PCR	PD1PCR	PD0PCR	
PEPCR	PE7PCR	PE6PCR	PE5PCR	PE4PCR	PE3PCR	PE2PCR	PE1PCR	PE0PCR	
P3ODR	—	P36ODR	—	—	—	P32ODR	P31ODR	P30ODR	
PAODR	—	—	—	—	PA3ODR	PA2ODR	PA1ODR	PA0ODR	
TSTR	—	—	—	—	—	CST2	CST1	CST0	TPU
TSYR	—	—	—	—	—	SYNC2	SYNC1	SYNC0	
IPRA	—	IPRA6	IPRA5	IPRA4	—	IPRA2	IPRA1	IPRA0	INT
IPRB	—	IPRB6	IPRB5	IPRB4	—	IPRB2	IPRB1	IPRB0	
IPRC	—	IPRC6	IPRC5	IPRC4	—	—	—	—	
IPRD	—	IPRD6	IPRD5	IPRD4	—	—	—	—	
IPRE	—	—	—	—	—	IPRE2	IPRE1	IPRE0	
IPRF	—	IPRF6	IPRF5	IPRF4	—	IPRF2	IPRF1	IPRF0	
IPRG	—	IPRG6	IPRG5	IPRG4	—	—	—	—	
IPRJ	—	IPRJ6	IPRJ5	IPRJ4	—	IPRJ2	IPRJ1	IPRJ0	
IPRK	—	—	—	—	—	IPRK2	IPRK1	IPRK0	
IPRM	—	IPRM6	IPRM5	IPRM4	—	—	—	—	

Register Name	Bit 7	Bit 6	Bit 5	Bit 4	Bit 3	Bit 2	Bit 1	Bit 0	Module
ABWCR	ABW7	ABW6	ABW5	ABW4	ABW3	ABW2	ABW1	ABW0	BSC
ASTCR	AST7	AST6	AST5	AST4	AST3	AST2	AST1	AST0	
WCRH	W71	W70	W61	W60	W51	W50	W41	W40	
WCRL	W31	W30	W21	W20	W11	W10	W01	W00	
BCRH	ICIS1	ICIS0	BRSTRM	BRSTS1	BRSTS0	RMTS2	RMTS1	RMTS0	
BCRL	BRLE	—	—	—	—	—	—	WAITE	
RAMER	—	—	—	—	RAMS	—	RAM1	RAM0	FLASH
MAR0A	—	—	—	—	—	—	—	—	DMAC
	Bit 23	Bit 22	Bit 21	Bit 20	Bit 19	Bit 18	Bit 17	Bit 16	
	Bit 15	Bit 14	Bit 13	Bit 12	Bit 11	Bit 10	Bit 9	Bit 8	
	Bit 7	Bit 6	Bit 5	Bit 4	Bit 3	Bit 2	Bit 1	Bit 0	
IOAR0A	Bit 15	Bit 14	Bit 13	Bit 12	Bit 11	Bit 10	Bit 9	Bit 8	
	Bit 7	Bit 6	Bit 5	Bit 4	Bit 3	Bit 2	Bit 1	Bit 0	
ETCR0A	Bit 15	Bit 14	Bit 13	Bit 12	Bit 11	Bit 10	Bit 9	Bit 8	
	Bit 7	Bit 6	Bit 5	Bit 4	Bit 3	Bit 2	Bit 1	Bit 0	
MAR0B	—	—	—	—	—	—	—	—	
	Bit 23	Bit 22	Bit 21	Bit 20	Bit 19	Bit 18	Bit 17	Bit 16	
	Bit 15	Bit 14	Bit 13	Bit 12	Bit 11	Bit 10	Bit 9	Bit 8	
	Bit 7	Bit 6	Bit 5	Bit 4	Bit 3	Bit 2	Bit 1	Bit 0	
IOAR0B	Bit 15	Bit 14	Bit 13	Bit 12	Bit 11	Bit 10	Bit 9	Bit 8	
	Bit 7	Bit 6	Bit 5	Bit 4	Bit 3	Bit 2	Bit 1	Bit 0	
ETCR0B	Bit 15	Bit 14	Bit 13	Bit 12	Bit 11	Bit 10	Bit 9	Bit 8	
	Bit 7	Bit 6	Bit 5	Bit 4	Bit 3	Bit 2	Bit 1	Bit 0	
MAR1A	—	—	—	—	—	—	—	—	
	Bit 23	Bit 22	Bit 21	Bit 20	Bit 19	Bit 18	Bit 17	Bit 16	
	Bit 15	Bit 14	Bit 13	Bit 12	Bit 11	Bit 10	Bit 9	Bit 8	
	Bit 7	Bit 6	Bit 5	Bit 4	Bit 3	Bit 2	Bit 1	Bit 0	
IOAR1A	Bit 15	Bit 14	Bit 13	Bit 12	Bit 11	Bit 10	Bit 9	Bit 8	
	Bit 7	Bit 6	Bit 5	Bit 4	Bit 3	Bit 2	Bit 1	Bit 0	
ETCR1A	Bit 15	Bit 14	Bit 13	Bit 12	Bit 11	Bit 10	Bit 9	Bit 8	
	Bit 7	Bit 6	Bit 5	Bit 4	Bit 3	Bit 2	Bit 1	Bit 0	

## Section 21 List of Registers

Register									
Name	Bit 7	Bit 6	Bit 5	Bit 4	Bit 3	Bit 2	Bit 1	Bit 0	Module
MAR1B	—	—	—	—	—	—	—	—	DMAC
	Bit 23	Bit 22	Bit 21	Bit 20	Bit 19	Bit 18	Bit 17	Bit 16	
	Bit 15	Bit 14	Bit 13	Bit 12	Bit 11	Bit 10	Bit 9	Bit 8	
	Bit 7	Bit 6	Bit 5	Bit 4	Bit 3	Bit 2	Bit 1	Bit 0	
IOAR1B	Bit 15	Bit 14	Bit 13	Bit 12	Bit 11	Bit 10	Bit 9	Bit 8	
	Bit 7	Bit 6	Bit 5	Bit 4	Bit 3	Bit 2	Bit 1	Bit 0	
ETCR1B	Bit 15	Bit 14	Bit 13	Bit 12	Bit 11	Bit 10	Bit 9	Bit 8	
	Bit 7	Bit 6	Bit 5	Bit 4	Bit 3	Bit 2	Bit 1	Bit 0	
P1DR	P17DR	P16DR	P15DR	P14DR	P13DR	P12DR	P11DR	P10DR	PORT
P3DR	—	P36DR	—	—	—	P32DR	P31DR	P30DR	
P7DR	P77DR	P76DR	P75DR	P74DR	—	—	P71DR	P70DR	
PADR	—	—	—	—	PA3DR	PA2DR	PA1DR	PA0DR	
PBDR	PB7DR	PB6DR	PB5DR	PB4DR	PB3DR	PB2DR	PB1DR	PB0DR	
PCDR	PC7DR	PC6DR	PC5DR	PC4DR	PC3DR	PC2DR	PC1DR	PC0DR	
PDDR	PD7DR	PD6DR	PD5DR	PD4DR	PD3DR	PD2DR	PD1DR	PD0DR	
PEDR	PE7DR	PE6DR	PE5DR	PE4DR	PE3DR	PE2DR	PE1DR	PE0DR	
PFDR	PF7DR	PF6DR	PF5DR	PF4DR	PF3DR	PF2DR	PF1DR	PF0DR	
PGDR	—	—	—	PG4DR	PG3DR	PG2DR	PG1DR	PG0DR	
TCR_0	CCLR2	CCLR1	CCLR0	CKEG1	CKEG0	TPSC2	TPSC1	TPSC0	TPU_0
TMDR_0	—	—	BFB	BFA	MD3	MD2	MD1	MD0	
TIORH_0	IOB3	IOB2	IOB1	IOB0	IOA3	IOA2	IOA1	IOA0	
TIORL_0	IOD3	IOD2	IOD1	IOD0	IOC3	IOC2	IOC1	IOC0	
TIER_0	TTGE	—	—	TCIEV	TGIED	TGIEC	TGIEB	TGIEA	
TSR_0	—	—	—	TCFV	TGFD	TGFC	TGFB	TGFA	
TCNT_0	Bit 15	Bit 14	Bit 13	Bit 12	Bit 11	Bit 10	Bit 9	Bit 8	
	Bit 7	Bit 6	Bit 5	Bit 4	Bit 3	Bit 2	Bit 1	Bit 0	
TGRA_0	Bit 15	Bit 14	Bit 13	Bit 12	Bit 11	Bit 10	Bit 9	Bit 8	
	Bit 7	Bit 6	Bit 5	Bit 4	Bit 3	Bit 2	Bit 1	Bit 0	
TGRB_0	Bit 15	Bit 14	Bit 13	Bit 12	Bit 11	Bit 10	Bit 9	Bit 8	
	Bit 7	Bit 6	Bit 5	Bit 4	Bit 3	Bit 2	Bit 1	Bit 0	

Register Name	Bit 7	Bit 6	Bit 5	Bit 4	Bit 3	Bit 2	Bit 1	Bit 0	Module
TGRC_0	Bit 15	Bit 14	Bit 13	Bit 12	Bit 11	Bit 10	Bit 9	Bit 8	TPU_0
	Bit 7	Bit 6	Bit 5	Bit 4	Bit 3	Bit 2	Bit 1	Bit 0	
TGRD_0	Bit 15	Bit 14	Bit 13	Bit 12	Bit 11	Bit 10	Bit 9	Bit 8	
	Bit 7	Bit 6	Bit 5	Bit 4	Bit 3	Bit 2	Bit 1	Bit 0	
TCR_1	—	CCLR1	CCLR0	CKEG1	CKEG0	TPSC2	TPSC1	TPSC0	TPU_1
TMDR_1	—	—	—	—	MD3	MD2	MD1	MD0	
TIOR_1	IOB3	IOB2	IOB1	IOB0	IOA3	IOA2	IOA1	IOA0	
TIER_1	TTGE	—	TCIEU	TCIEV	—	—	TGIEB	TGIEA	
TSR_1	TCFD	—	TCFU	TCFV	—	—	TGFB	TGFA	
TCNT_1	Bit 15	Bit 14	Bit 13	Bit 12	Bit 11	Bit 10	Bit 9	Bit 8	
	Bit 7	Bit 6	Bit 5	Bit 4	Bit 3	Bit 2	Bit 1	Bit 0	
TGRA_1	Bit 15	Bit 14	Bit 13	Bit 12	Bit 11	Bit 10	Bit 9	Bit 8	
	Bit 7	Bit 6	Bit 5	Bit 4	Bit 3	Bit 2	Bit 1	Bit 0	
TGRB_1	Bit 15	Bit 14	Bit 13	Bit 12	Bit 11	Bit 10	Bit 9	Bit 8	
	Bit 7	Bit 6	Bit 5	Bit 4	Bit 3	Bit 2	Bit 1	Bit 0	
TCR_2	—	CCLR1	CCLR0	CKEG1	CKEG0	TPSC2	TPSC1	TPSC0	TPU_2
TMDR_2	—	—	—	—	MD3	MD2	MD1	MD0	
TIOR_2	IOB3	IOB2	IOB1	IOB0	IOA3	IOA2	IOA1	IOA0	
TIER_2	TTGE	—	TCIEU	TCIEV	—	—	TGIEB	TGIEA	
TSR_2	TCFD	—	TCFU	TCFV	—	—	TGFB	TGFA	
TCNT_2	Bit 15	Bit 14	Bit 13	Bit 12	Bit 11	Bit 10	Bit 9	Bit 8	
	Bit 7	Bit 6	Bit 5	Bit 4	Bit 3	Bit 2	Bit 1	Bit 0	
TGRA_2	Bit 15	Bit 14	Bit 13	Bit 12	Bit 11	Bit 10	Bit 9	Bit 8	
	Bit 7	Bit 6	Bit 5	Bit 4	Bit 3	Bit 2	Bit 1	Bit 0	
TGRB_2	Bit 15	Bit 14	Bit 13	Bit 12	Bit 11	Bit 10	Bit 9	Bit 8	
	Bit 7	Bit 6	Bit 5	Bit 4	Bit 3	Bit 2	Bit 1	Bit 0	
EXMDLSTP	—	—	—	—	—	—	RTCSTOP	USBSTOP1	SYSTEM

## Section 21 List of Registers

Register Name	Bit 7	Bit 6	Bit 5	Bit 4	Bit 3	Bit 2	Bit 1	Bit 0	Module
RSECDR	BSY	SC12	SC11	SC10	SC03	SC02	SC01	SC00	RTC
RMINDR	BSY	MN12	MN11	MN10	MN03	MN02	MN01	MN00	
RHRDR	BSY	—	HR11	HR10	HR03	HR02	HR01	HR00	
RWKDR	BSY	—	—	—	—	WK2	WK1	KWK0	
RTCCR1	RUN	12/24	PM	RST	—	—	—	—	
RTCCR2	—	—	FOIE	WKIE	DYIE	HRIE	MNIE	SEIE	
RTCCSR	—	RCS6	RCS5	—	RCS3	RCS2	RCS1	RCS0	
DMACR0A* <sup>1</sup>	DTSZ	DTID	RPE	DTDIR	DTF3	DTF2	DTF1	DTF0	DMAC
DMACR0A* <sup>2</sup>	DTSZ	SAID	SAIDE	BLKDIR	BLKE	—	—	—	
DMACR0B* <sup>1</sup>	DTSZ	DTID	RPE	DTDIR	DTF3	DTF2	DTF1	DTF0	
DMACR0B* <sup>2</sup>	—	DAID	DAIDE	—	DTF3	DTF2	DTF1	DTF0	
DMACR1A* <sup>1</sup>	DTSZ	DTID	RPE	DTDIR	DTF3	DTF2	DTF1	DTF0	
DMACR1A* <sup>2</sup>	DTSZ	SAID	SAIDE	BLKDIR	BLKE	—	—	—	
DMACR1B* <sup>1</sup>	DTSZ	DTID	RPE	DTDIR	DTF3	DTF2	DTF1	DTF0	
DMACR1B* <sup>2</sup>	—	DAID	DAIDE	—	DTF3	DTF2	DTF1	DTF0	
DMABCR* <sup>1</sup>	FAE1	FAE0	—	—	DTA1B	DTA1A	DTA0B	DTA0A	
	DTE1B	DTE1A	DTE0B	DTE0A	DTIE1B	DTIE1A	DTIE0B	DTIE0A	
DMABCR* <sup>2</sup>	FAE1	FAE0	—	—	DTA1	—	DTA0	—	
	DTME1	DTE1	DTME0	DTE0	DTIE1B	DTIE1A	DTIE0B	DTIE0A	
TCSR	OVF	WT/IT	TME	—	—	CKS2	CKS1	CKS0	WDT
TCNT	Bit 7	Bit 6	Bit 5	Bit 4	Bit 3	Bit 2	Bit 1	Bit 0	
RSTCSR	WOVF	RSTE	RSTS	—	—	—	—	—	
SMR_0	C/A	CHR	PE	O/E	STOP	MP	CKS1	CKS0	SCI_0
SMR_0* <sup>3</sup>	GM	BLK	PE	O/E	BCP1	BCP0	CKS1	CKS0	
BRR_0	Bit 7	Bit 6	Bit 5	Bit 4	Bit 3	Bit 2	Bit 1	Bit 0	
SCR_0	TIE	RIE	TE	RE	MPIE	TEIE	CKE1	CKE0	
TDR_0	Bit 7	Bit 6	Bit 5	Bit 4	Bit 3	Bit 2	Bit 1	Bit 0	
SSR_0	TDRE	RDRF	ORER	FER	PER	TEND	MPB	MPBT	
SSR_0* <sup>3</sup>	TDRE	RDRF	ORER	ERS	PER	TEND	MPB	MPBT	
RDR_0	Bit 7	Bit 6	Bit 5	Bit 4	Bit 3	Bit 2	Bit 1	Bit 0	
SCMR_0	—	—	—	—	SDIR	SINV	—	SMIF	

Register									
Name	Bit 7	Bit 6	Bit 5	Bit 4	Bit 3	Bit 2	Bit 1	Bit 0	Module
SMR_2	C/ $\bar{A}$	CHR	PE	O/ $\bar{E}$	STOP	MP	CKS1	CKS0	SCI_2
SMR_2* <sup>3</sup>	GM	BLK	PE	O/ $\bar{E}$	BCP1	BCP0	CKS1	CKS0	
BRR_2	Bit 7	Bit 6	Bit 5	Bit 4	Bit 3	Bit 2	Bit 1	Bit 0	
SCR_2	TIE	RIE	TE	RE	MPIE	TEIE	CKE1	CKE0	
TDR_2	Bit 7	Bit 6	Bit 5	Bit 4	Bit 3	Bit 2	Bit 1	Bit 0	
SSR_2	TDRE	RDRF	ORER	FER	PER	TEND	MPB	MPBT	
SSR_2* <sup>3</sup>	TDRE	RDRF	ORER	ERS	PER	TEND	MPB	MPBT	
RDR_2	Bit 7	Bit 6	Bit 5	Bit 4	Bit 3	Bit 2	Bit 1	Bit 0	
SCMR_2	—	—	—	—	SDIR	SINV	—	SMIF	
ADDRAH	AD9	AD8	AD7	AD6	AD5	AD4	AD3	AD2	A/D
ADDRAL	AD1	AD0	—	—	—	—	—	—	
ADDRBH	AD9	AD8	AD7	AD6	AD5	AD4	AD3	AD2	
ADDRBL	AD1	AD0	—	—	—	—	—	—	
ADDRCH	AD9	AD8	AD7	AD6	AD5	AD4	AD3	AD2	
ADDRCL	AD1	AD0	—	—	—	—	—	—	
ADDRDH	AD9	AD8	AD7	AD6	AD5	AD4	AD3	AD2	
ADDRDL	AD1	AD0	—	—	—	—	—	—	
ADCSR	ADF	ADIE	ADST	SCAN	—	CH2	CH1	CH0	
ADCR	TRGS1	TRGS0	—	—	CKS1	CKS0	—	—	
TCSR_1	—	—	—	PSS	—	—	—	—	SYSTEM
FLMCR1	FWE	SWE1	ESU1	PSU1	EV1	PV1	E1	P1	FLASH
FLMCR2	FLER	—	—	—	—	—	—	—	
EBR1	EB7	EB6	EB5	EB4	EB3	EB2	EB1	EB0	
EBR2	—	—	—	—	—	—	EB9	EB8	

**Register**

<b>Name</b>	<b>Bit 7</b>	<b>Bit 6</b>	<b>Bit 5</b>	<b>Bit 4</b>	<b>Bit 3</b>	<b>Bit 2</b>	<b>Bit 1</b>	<b>Bit 0</b>	<b>Module</b>
PORT1	P17	P16	P15	P14	P13	P12	P11	P10	PORT
PORT3	—	P36	—	—	—	P32	P31	P30	
PORT4	—	—	—	—	P43	P42	P41	P40	
PORT7	P77	P76	P75	P74	—	—	P71	P70	
PORT9	P97	P96	—	—	—	—	—	—	
PORTA	—	—	—	—	PA3	PA2	PA1	PA0	
PORTB	PB7	PB6	PB5	PB4	PB3	PB2	PB1	PB0	
PORTC	PC7	PC6	PC5	PC4	PC3	PC2	PC1	PC0	
PORTD	PD7	PD6	PD5	PD4	PD3	PD2	PD1	PD0	
PORTE	PE7	PE6	PE5	PE4	PE3	PE2	PE1	PE0	
PORTF	PF7	PF6	PF5	PF4	PF3	PF2	PF1	PF0	
PORTG	—	—	—	PG4	PG3	PG2	PG1	PG0	

---

Notes: 1. Short address mode  
2. Full address mode  
3. Smart card interface



## 21.3 Register States in Each Operating Mode

Register Name	Power-on Reset	Manual Reset	High-Speed	Medium-Speed	Sleep	Module				Software	Hardware	Module
						Stop	Watch	Subactive	Subsleep	Standby	Standby	
UCTLR	Initialized*	—	—	—	—	—	—	—	—	—	Initialized	USB
UTSTRA	Initialized*	—	—	—	—	—	—	—	—	—	Initialized	
UDMAR	Initialized*	—	—	—	—	—	—	—	—	—	Initialized	
UDRR	Initialized*	—	—	—	—	—	—	—	—	—	Initialized	
UTRG0	Initialized*	—	—	—	—	—	—	—	—	—	Initialized	
UFCLR0	Initialized*	—	—	—	—	—	—	—	—	—	Initialized	
UESTL0	Initialized*	—	—	—	—	—	—	—	—	—	Initialized	
UESTL1	Initialized*	—	—	—	—	—	—	—	—	—	Initialized	
UEDR0s	—*	—	—	—	—	—	—	—	—	—	—	
UEDR0i	Initialized*	—	—	—	—	—	—	—	—	—	Initialized	
UEDR0o	—*	—	—	—	—	—	—	—	—	—	—	
UEDR3	Initialized*	—	—	—	—	—	—	—	—	—	Initialized	
UEDR1	Initialized*	—	—	—	—	—	—	—	—	—	Initialized	
UEDR2	—*	—	—	—	—	—	—	—	—	—	—	
UESZ0o	—*	—	—	—	—	—	—	—	—	—	—	
UESZ2	—*	—	—	—	—	—	—	—	—	—	—	
UIFR0	Initialized*	—	—	—	—	—	—	—	—	—	Initialized	
UIFR1	Initialized*	—	—	—	—	—	—	—	—	—	Initialized	
UIFR3	Initialized*	—	—	—	—	—	—	—	—	—	Initialized	
UIER0	Initialized*	—	—	—	—	—	—	—	—	—	Initialized	
UIER1	Initialized*	—	—	—	—	—	—	—	—	—	Initialized	
UIER3	Initialized*	—	—	—	—	—	—	—	—	—	Initialized	
UISR0	Initialized*	—	—	—	—	—	—	—	—	—	Initialized	
UISR1	Initialized*	—	—	—	—	—	—	—	—	—	Initialized	
UISR3	Initialized*	—	—	—	—	—	—	—	—	—	Initialized	
UDSR	Initialized*	—	—	—	—	—	—	—	—	—	Initialized	
UCVR	Initialized*	—	—	—	—	—	—	—	—	—	Initialized	

## Section 21 List of Registers

Register Name	Power-on	Manual	High-	Medium-	Module					Software	Hardware	Module
	Reset	Reset	Speed	Speed	Sleep	Stop	Watch	Subactive	Subsleep	Standby	Standby	
UTSTR0	Initialized*	—	—	—	—	—	—	—	—	—	Initialized	USB
UTSTR1	Initialized*	—	—	—	—	—	—	—	—	—	Initialized	
UTSTR2	Initialized*	—	—	—	—	—	—	—	—	—	Initialized	
UTSTRB	Initialized*	—	—	—	—	—	—	—	—	—	Initialized	
UTSTRC	Initialized*	—	—	—	—	—	—	—	—	—	Initialized	
UTSTRD	Initialized*	—	—	—	—	—	—	—	—	—	Initialized	
UTSTRE	Initialized*	—	—	—	—	—	—	—	—	—	Initialized	
UTSTRF	Initialized*	—	—	—	—	—	—	—	—	—	Initialized	
SCRX	Initialized	Initialized	—	—	—	—	—	—	—	—	Initialized	FLASH
SBYCR	Initialized	Initialized	—	—	—	—	—	—	—	—	Initialized	SYSTEM
SYSCR	Initialized	Initialized	—	—	—	—	—	—	—	—	Initialized	
SCKCR	Initialized	Initialized	—	—	—	—	—	—	—	—	Initialized	
MDCR	Initialized	—	—	—	—	—	—	—	—	—	Initialized	
MSTPCRA	Initialized	Initialized	—	—	—	—	—	—	—	—	Initialized	
MSTPCRB	Initialized	Initialized	—	—	—	—	—	—	—	—	Initialized	
MSTPCRC	Initialized	Initialized	—	—	—	—	—	—	—	—	Initialized	
PFCR	Initialized	—	—	—	—	—	—	—	—	—	Initialized	BSC
LPWRCR	Initialized	—	—	—	—	—	—	—	—	—	Initialized	SYSTEM
OUTCR	Initialized	Initialized	—	—	—	—	—	—	—	—	Initialized	PORT
SEMRA_0	Initialized	Initialized	—	—	—	—	—	—	—	—	Initialized	SCL_0
SEMRB_0	Initialized	Initialized	—	—	—	—	—	—	—	—	Initialized	
ISCRH	Initialized	Initialized	—	—	—	—	—	—	—	—	Initialized	INT
ISCLR	Initialized	Initialized	—	—	—	—	—	—	—	—	Initialized	
IER	Initialized	Initialized	—	—	—	—	—	—	—	—	Initialized	
ISR	Initialized	Initialized	—	—	—	—	—	—	—	—	Initialized	
P1DDR	Initialized	—	—	—	—	—	—	—	—	—	Initialized	PORT
P3DDR	Initialized	—	—	—	—	—	—	—	—	—	Initialized	
P7DDR	Initialized	—	—	—	—	—	—	—	—	—	Initialized	
PADDR	Initialized	—	—	—	—	—	—	—	—	—	Initialized	
PBDDR	Initialized	—	—	—	—	—	—	—	—	—	Initialized	
PCDDR	Initialized	—	—	—	—	—	—	—	—	—	Initialized	

Register Name	Power-on	Manual	High-	Medium-	Module					Software	Hardware	Module	
	Reset	Reset	Speed	Speed	Sleep	Stop	Watch	Subactive	Subsleep	Standby	Standby		
PDDDR	Initialized	—	—	—	—	—	—	—	—	—	—	Initialized	PORT
PEDDR	Initialized	—	—	—	—	—	—	—	—	—	—	Initialized	
PFDDR	Initialized	—	—	—	—	—	—	—	—	—	—	Initialized	
PGDDR	Initialized	—	—	—	—	—	—	—	—	—	—	Initialized	
PAPCR	Initialized	—	—	—	—	—	—	—	—	—	—	Initialized	
PBPCR	Initialized	—	—	—	—	—	—	—	—	—	—	Initialized	
PCPCR	Initialized	—	—	—	—	—	—	—	—	—	—	Initialized	
PDPCR	Initialized	—	—	—	—	—	—	—	—	—	—	Initialized	
PEPCR	Initialized	—	—	—	—	—	—	—	—	—	—	Initialized	
P3ODR	Initialized	—	—	—	—	—	—	—	—	—	—	Initialized	
PAODR	Initialized	—	—	—	—	—	—	—	—	—	—	Initialized	
TSTR	Initialized	Initialized	—	—	—	—	—	—	—	—	—	Initialized	TPU
TSYR	Initialized	Initialized	—	—	—	—	—	—	—	—	—	Initialized	
IPRA	Initialized	Initialized	—	—	—	—	—	—	—	—	—	Initialized	INT
IPRB	Initialized	Initialized	—	—	—	—	—	—	—	—	—	Initialized	
IPRC	Initialized	Initialized	—	—	—	—	—	—	—	—	—	Initialized	
IPRD	Initialized	Initialized	—	—	—	—	—	—	—	—	—	Initialized	
IPRE	Initialized	Initialized	—	—	—	—	—	—	—	—	—	Initialized	
IPRF	Initialized	Initialized	—	—	—	—	—	—	—	—	—	Initialized	
IPRG	Initialized	Initialized	—	—	—	—	—	—	—	—	—	Initialized	
IPRJ	Initialized	Initialized	—	—	—	—	—	—	—	—	—	Initialized	
IPRK	Initialized	Initialized	—	—	—	—	—	—	—	—	—	Initialized	
IPRM	Initialized	Initialized	—	—	—	—	—	—	—	—	—	Initialized	
ABWCR	Initialized	—	—	—	—	—	—	—	—	—	—	Initialized	BSC
ASTCR	Initialized	—	—	—	—	—	—	—	—	—	—	Initialized	
WCRH	Initialized	—	—	—	—	—	—	—	—	—	—	Initialized	
WCRL	Initialized	—	—	—	—	—	—	—	—	—	—	Initialized	
BCRH	Initialized	—	—	—	—	—	—	—	—	—	—	Initialized	
BCRL	Initialized	—	—	—	—	—	—	—	—	—	—	Initialized	
RAMER	Initialized	—	—	—	—	—	—	—	—	—	—	Initialized	FLASH

## Section 21 List of Registers

Register Name	Power-on	Manual	High-	Medium-	Sleep	Module				Software	Hardware	Module
	Reset	Reset	Speed	Speed		Stop	Watch	Subactive	Subsleep	Standby	Standby	
MAR0A	—	—	—	—	—	—	—	—	—	—	—	DMAC
IOAR0A	—	—	—	—	—	—	—	—	—	—	—	
ETCR0A	—	—	—	—	—	—	—	—	—	—	—	
MAR0B	—	—	—	—	—	—	—	—	—	—	—	
IOAR0B	—	—	—	—	—	—	—	—	—	—	—	
ETCR0B	—	—	—	—	—	—	—	—	—	—	—	
MAR1A	—	—	—	—	—	—	—	—	—	—	—	
IOAR1A	—	—	—	—	—	—	—	—	—	—	—	
ETCR1A	—	—	—	—	—	—	—	—	—	—	—	
MAR1B	—	—	—	—	—	—	—	—	—	—	—	
IOAR1B	—	—	—	—	—	—	—	—	—	—	—	
ETCR1B	—	—	—	—	—	—	—	—	—	—	—	
P1DR	Initialized	—	—	—	—	—	—	—	—	—	Initialized	PORT
P3DR	Initialized	—	—	—	—	—	—	—	—	—	Initialized	
P7DR	Initialized	—	—	—	—	—	—	—	—	—	Initialized	
PADR	Initialized	—	—	—	—	—	—	—	—	—	Initialized	
PBDR	Initialized	—	—	—	—	—	—	—	—	—	Initialized	
PCDR	Initialized	—	—	—	—	—	—	—	—	—	Initialized	
PDDR	Initialized	—	—	—	—	—	—	—	—	—	Initialized	
PEDR	Initialized	—	—	—	—	—	—	—	—	—	Initialized	
PFDR	Initialized	—	—	—	—	—	—	—	—	—	Initialized	
PGDR	Initialized	—	—	—	—	—	—	—	—	—	Initialized	
TCR_0	Initialized	Initialized	—	—	—	—	—	—	—	—	Initialized	TPU_0
TMDR_0	Initialized	Initialized	—	—	—	—	—	—	—	—	Initialized	
TIORH_0	Initialized	Initialized	—	—	—	—	—	—	—	—	Initialized	
TIORL_0	Initialized	Initialized	—	—	—	—	—	—	—	—	Initialized	
TIER_0	Initialized	Initialized	—	—	—	—	—	—	—	—	Initialized	
TSR_0	Initialized	Initialized	—	—	—	—	—	—	—	—	Initialized	
TCNT_0	Initialized	Initialized	—	—	—	—	—	—	—	—	Initialized	
TGRA_0	Initialized	Initialized	—	—	—	—	—	—	—	—	Initialized	
TGRB_0	Initialized	Initialized	—	—	—	—	—	—	—	—	Initialized	
TGRC_0	Initialized	Initialized	—	—	—	—	—	—	—	—	Initialized	
TGRD_0	Initialized	Initialized	—	—	—	—	—	—	—	—	Initialized	

Register Name	Power-on	Manual	High-	Medium-	Module					Software	Hardware	
	Reset	Reset	Speed	Speed	Sleep	Stop	Watch	Subactive	Subsleep	Standby	Standby	
TCR_1	Initialized	Initialized	—	—	—	—	—	—	—	—	Initialized	TPU_1
TMDR_1	Initialized	Initialized	—	—	—	—	—	—	—	—	Initialized	
TIOR_1	Initialized	Initialized	—	—	—	—	—	—	—	—	Initialized	
TIER_1	Initialized	Initialized	—	—	—	—	—	—	—	—	Initialized	
TSR_1	Initialized	Initialized	—	—	—	—	—	—	—	—	Initialized	
TCNT_1	Initialized	Initialized	—	—	—	—	—	—	—	—	Initialized	
TGRA_1	Initialized	Initialized	—	—	—	—	—	—	—	—	Initialized	
TGRB_1	Initialized	Initialized	—	—	—	—	—	—	—	—	Initialized	
TCR_2	Initialized	Initialized	—	—	—	—	—	—	—	—	Initialized	TPU_2
TMDR_2	Initialized	Initialized	—	—	—	—	—	—	—	—	Initialized	
TIOR_2	Initialized	Initialized	—	—	—	—	—	—	—	—	Initialized	
TIER_2	Initialized	Initialized	—	—	—	—	—	—	—	—	Initialized	
TSR_2	Initialized	Initialized	—	—	—	—	—	—	—	—	Initialized	
TCNT_2	Initialized	Initialized	—	—	—	—	—	—	—	—	Initialized	
TGRA_2	Initialized	Initialized	—	—	—	—	—	—	—	—	Initialized	
TGRB_2	Initialized	Initialized	—	—	—	—	—	—	—	—	Initialized	
EXMDLSTP	Initialized	—	—	—	—	—	—	—	—	—	Initialized	SYSTEM
RSECDR	—	—	—	—	—	—	—	—	—	—	Initialized	RTC
RMINDR	—	—	—	—	—	—	—	—	—	—	Initialized	
RHRDR	—	—	—	—	—	—	—	—	—	—	Initialized	
RWKDR	—	—	—	—	—	—	—	—	—	—	Initialized	
RTCCR1	—	—	—	—	—	—	—	—	—	—	Initialized	
RTCCR2	—	—	—	—	—	—	—	—	—	—	Initialized	
RTCCSR	Initialized	—	—	—	—	—	—	—	—	—	Initialized	
DMACR0A	Initialized	Initialized	—	—	—	—	—	—	—	—	Initialized	DMAC
DMACR0B	Initialized	Initialized	—	—	—	—	—	—	—	—	Initialized	
DMACR1A	Initialized	Initialized	—	—	—	—	—	—	—	—	Initialized	
DMACR1B	Initialized	Initialized	—	—	—	—	—	—	—	—	Initialized	
DMABCR	Initialized	Initialized	—	—	—	—	—	—	—	—	Initialized	
TCSR	Initialized	Initialized	—	—	—	—	—	—	—	—	Initialized	WDT
TCNT	Initialized	Initialized	—	—	—	—	—	—	—	—	Initialized	
RSTCSR	Initialized	Initialized	—	—	—	—	—	—	—	—	Initialized	

## Section 21 List of Registers

Register Name	Power-on Reset	Manual Reset	High-Speed	Medium-Speed	Sleep	Module Stop	Watch	Subactive	Subsleep	Software Standby	Hardware Standby	Module
SMR_0	Initialized	Initialized	—	—	—	—	—	—	—	—	Initialized	SCL_0
BRR_0	Initialized	Initialized	—	—	—	—	—	—	—	—	Initialized	
SCR_0	Initialized	Initialized	—	—	—	—	—	—	—	—	Initialized	
TDR_0	Initialized	Initialized	—	—	—	Initialized	Initialized	Initialized	Initialized	Initialized	Initialized	
SSR_0	Initialized	Initialized	—	—	—	Initialized	Initialized	Initialized	Initialized	Initialized	Initialized	
RDR_0	Initialized	Initialized	—	—	—	Initialized	Initialized	Initialized	Initialized	Initialized	Initialized	
SCMR_0	Initialized	Initialized	—	—	—	—	—	—	—	—	Initialized	
SMR_2	Initialized	Initialized	—	—	—	—	—	—	—	—	Initialized	SCL_2
BRR_2	Initialized	Initialized	—	—	—	—	—	—	—	—	Initialized	
SCR_2	Initialized	Initialized	—	—	—	—	—	—	—	—	Initialized	
TDR_2	Initialized	Initialized	—	—	—	Initialized	Initialized	Initialized	Initialized	Initialized	Initialized	
SSR_2	Initialized	Initialized	—	—	—	Initialized	Initialized	Initialized	Initialized	Initialized	Initialized	
RDR_2	Initialized	Initialized	—	—	—	Initialized	Initialized	Initialized	Initialized	Initialized	Initialized	
SCMR_2	Initialized	Initialized	—	—	—	—	—	—	—	—	Initialized	
ADDRAH	Initialized	Initialized	—	—	—	Initialized	Initialized	Initialized	Initialized	Initialized	Initialized	A/D
ADDRAL	Initialized	Initialized	—	—	—	Initialized	Initialized	Initialized	Initialized	Initialized	Initialized	
ADDRBH	Initialized	Initialized	—	—	—	Initialized	Initialized	Initialized	Initialized	Initialized	Initialized	
ADDRBL	Initialized	Initialized	—	—	—	Initialized	Initialized	Initialized	Initialized	Initialized	Initialized	
ADDRCH	Initialized	Initialized	—	—	—	Initialized	Initialized	Initialized	Initialized	Initialized	Initialized	
ADDRCL	Initialized	Initialized	—	—	—	Initialized	Initialized	Initialized	Initialized	Initialized	Initialized	
ADDRDH	Initialized	Initialized	—	—	—	Initialized	Initialized	Initialized	Initialized	Initialized	Initialized	
ADDRDL	Initialized	Initialized	—	—	—	Initialized	Initialized	Initialized	Initialized	Initialized	Initialized	
ADCSR	Initialized	Initialized	—	—	—	Initialized	Initialized	Initialized	Initialized	Initialized	Initialized	
ADCR	Initialized	Initialized	—	—	—	Initialized	Initialized	Initialized	Initialized	Initialized	Initialized	
TCSR_1	Initialized	Initialized	—	—	—	—	—	—	—	Initialized	Initialized	SYSTEM
FLMCR1	Initialized	—	—	—	—	—	—	—	—	Initialized	Initialized	FLASH
FLMCR2	Initialized	—	—	—	—	—	—	—	—	Initialized	Initialized	
EBR1	Initialized	—	—	—	—	—	—	—	—	Initialized	Initialized	
EBR2	Initialized	—	—	—	—	—	—	—	—	Initialized	Initialized	

Register Name	Power-on	Manual	High-	Medium-	Module					Software	Hardware	Module
	Reset	Reset	Speed	Speed	Sleep	Stop	Watch	Subactive	Subsleep	Standby	Standby	
PORT1	—	—	—	—	—	—	—	—	—	—	—	PORT
PORT3	—	—	—	—	—	—	—	—	—	—	—	
PORT4	—	—	—	—	—	—	—	—	—	—	—	
PORT7	—	—	—	—	—	—	—	—	—	—	—	
PORT9	—	—	—	—	—	—	—	—	—	—	—	
PORTA	—	—	—	—	—	—	—	—	—	—	—	
PORTB	—	—	—	—	—	—	—	—	—	—	—	
PORTC	—	—	—	—	—	—	—	—	—	—	—	
PORTD	—	—	—	—	—	—	—	—	—	—	—	
PORTE	—	—	—	—	—	—	—	—	—	—	—	
PORTF	—	—	—	—	—	—	—	—	—	—	—	
PORTG	—	—	—	—	—	—	—	—	—	—	—	

Notes: — : is not initialized.

\* The USB registers are no initialized by a power-on reset triggered by the WDT.





## Section 22 Electrical Characteristics

### 22.1 Absolute Maximum Ratings

Table 22.1 lists the absolute maximum ratings.

**Table 22.1 Absolute Maximum Ratings**

Item	Symbol	Value	Unit
Power supply voltage	$V_{CC}$ , $PLL V_{CC}$ , $DrV_{CC}$	-0.3 to +4.3	V
Input voltage	$V_{in}$	-0.3 to $V_{CC} + 0.3$	V
Reference voltage	$V_{ref}$	-0.3 to $V_{CC} + 0.3$	V
Analog input voltage	$V_{AN}$	-0.3 to $V_{CC} + 0.3$	V
Operating temperature	$T_{opr}$	Regular specifications: -20 to +75	°C
		Wide-range specifications: -40 to +85*	°C
Storage temperature	$T_{stg}$	-55 to +125	°C

Caution: Permanent damage to the chip may result if absolute maximum rating are exceeded.

Note: \* The operating temperature ranges for flash memory programming/erasing are  $T_a = -20^{\circ}\text{C}$  to  $+75^{\circ}\text{C}$ .

## 22.2 Power Supply Voltage and Operating Frequency Range

Power supply voltage and operating frequency ranges (shaded areas) are shown in figure 22.1.

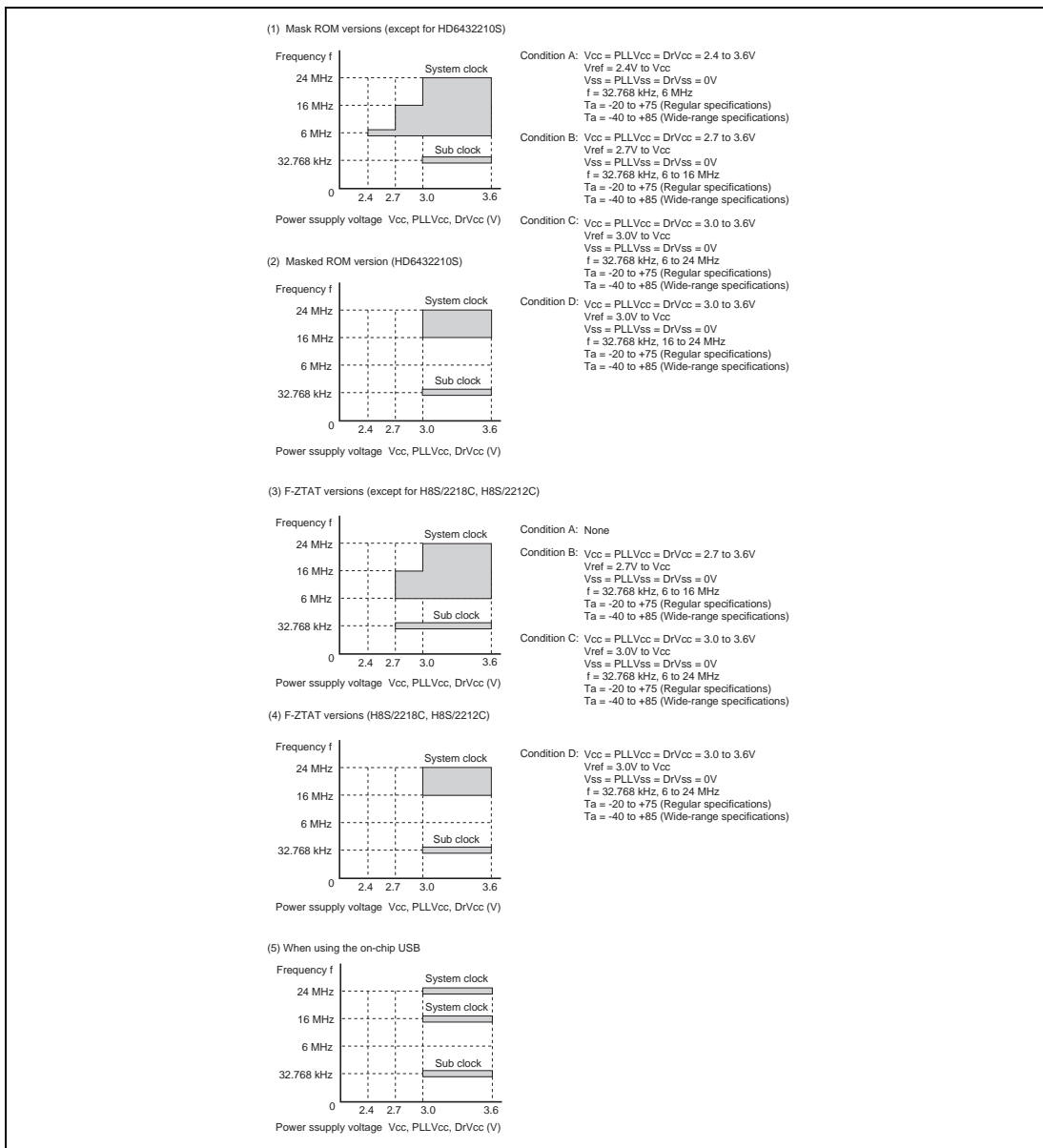


Figure 22.1 Power Supply Voltage and Operating Ranges

## 22.3 DC Characteristics

Table 22.2 lists the DC characteristics. Table 22.3 lists the permissible output currents.

**Table 22.2 DC Characteristics**

Condition A:  $V_{CC} = PLL$   $V_{CC} = Dr$   $V_{CC} = 2.4$  V to 3.6 V,  $V_{ref} = 2.4$  V to  $V_{CC}$ ,  $V_{SS} = PLLV_{SS} = Dr$   $V_{SS} = 0$  V,  $f = 32.768$  kHz, 6 MHz,  $T_a = -20^{\circ}C$  to  $+75^{\circ}C$  (regular specifications),  $T_a = -40^{\circ}C$  to  $+85^{\circ}C$  (wide-range specifications)

Condition B:  $V_{CC} = PLL$   $V_{CC} = Dr$   $V_{CC} = 2.7$  V to 3.6 V,  $V_{ref} = 2.7$  V to  $V_{CC}$ ,  $V_{SS} = PLLV_{SS} = Dr$   $V_{SS} = 0$  V,  $f = 32.768$  kHz, 6 MHz to 16 MHz,  $T_a = -20^{\circ}C$  to  $+75^{\circ}C$  (regular specifications),  $T_a = -40^{\circ}C$  to  $+85^{\circ}C$  (wide-range specifications)

Condition C:  $V_{CC} = PLL$   $V_{CC} = Dr$   $V_{CC} = 3.0$  V to 3.6 V,  $V_{ref} = 3.0$  V to  $V_{CC}$ ,  $V_{SS} = PLLV_{SS} = Dr$   $V_{SS} = 0$  V,  $f = 32.768$  kHz, 6 MHz to 24 MHz,  $T_a = -20^{\circ}C$  to  $+75^{\circ}C$  (regular specifications),  $T_a = -40^{\circ}C$  to  $+85^{\circ}C$  (wide-range specifications)

Condition D:  $V_{CC} = PLL$   $V_{CC} = Dr$   $V_{CC} = 3.0$  V to 3.6 V,  $V_{ref} = 3.0$  V to  $V_{CC}$ ,  $V_{SS} = PLLV_{SS} = Dr$   $V_{SS} = 0$  V,  $f = 32.768$  kHz, 16 MHz to 24 MHz,  $T_a = -20^{\circ}C$  to  $+75^{\circ}C$  (regular specifications),  $T_a = -40^{\circ}C$  to  $+85^{\circ}C$  (wide-range specifications)

Item	Symbol	Min.	Typ.	Max.	Unit	Test Conditions
Schmitt trigger input voltage	$\overline{IRQ0}$ to $\overline{IRQ4}$ $\overline{IRQ7}$	$V_T^-$ $V_T^+$ $V_T^+ - V_T^-$	$V_{CC} \times 0.2$ — $V_{CC} \times 0.05$	— — —	— $V_{CC} \times 0.8$ —	V V V
Input high voltage	$\overline{RES}$ , $\overline{STBY}$ , NMI, MD2 to MD0, $\overline{TRST}$ , TCK, TMS, TDI, EMLE, VBUS, $\overline{UBPM}$ , FWE* <sup>4</sup>	$V_{IH}$	$V_{CC} \times 0.9$	—	$V_{CC} + 0.3$	V
	EXTAL, ports 1, 3, 4, 7, 9, and A to G		$V_{CC} \times 0.8$	—	$V_{CC} + 0.3$	V

Item	Symbol	Min.	Typ.	Max.	Unit	Test Conditions	
Input low voltage	$\overline{RES}$ , $\overline{STBY}$ , MD2 to MD0, $\overline{TRST}$ , TCK, TMS, TDI, EMLE, VBUS, UBPM, FWE* <sup>4</sup>	$V_{IL}$	-0.3	—	$V_{CC} \times 0.1$	V	
	EXTAL, NMI, ports 1, 3, 4, 7, 9, and A to G		-0.3	—	$V_{CC} \times 0.2$	V	
Output high voltage	All output pins	$V_{OH}$	$V_{CC} - 0.5$	—	—	V	$I_{OH} = -200 \mu A$
			$V_{CC} - 1.0$	—	—	V	$I_{OH} = -1 \text{ mA}$
Output low voltage	All output pins	$V_{OL}$	—	—	0.4	V	$I_{OL} = 0.8 \text{ mA}$
Input leakage current	$\overline{RES}$ , VBUS, UBPM, $\overline{STBY}$ , NMI, EMLE, MD2 to MD0, FWE* <sup>4</sup> , ports 4, 9	$ I_{in} $	—	—	1.0	$\mu A$	$V_{in} = 0.5$ to $V_{CC} - 0.5 \text{ V}$
Three-state leakage current (off state)	Ports 1, 3, 7, and A to G	$ I_{TSL} $	—	—	1.0	$\mu A$	$V_{in} = 0.5$ to $V_{CC} - 0.5 \text{ V}$
Input pull-up MOS current	Ports A to E TDI, TCK, TMS, $\overline{TRST}$	$-I_P$	10	—	300	$\mu A$	$V_{in} = 0 \text{ V}$
Input capacitance	$\overline{RES}$ , NMI	$C_{in}$	—	—	30	pF	$V_{in} = 0 \text{ V}$ $f = 1 \text{ MHz}$
	All input pins other than $\overline{RES}$ , NMI		—	—	15	pF	$T_a = 25^\circ C$
Current dissipation* <sup>1</sup>	Normal operation	$I_{CC}^{*2}$	—	22	35	mA	$f = 16 \text{ MHz}$
	(USB halts)		—	31	50	mA	$f = 24 \text{ MHz}$
				$V_{CC} = 3.3 \text{ V}$	$V_{CC} = 3.6 \text{ V}$		
				$V_{CC} = 3.3 \text{ V}$	$V_{CC} = 3.6 \text{ V}$		

Item		Symbol	Min.	Typ.	Max.	Unit	Test Conditions
Current dissipation* <sup>1</sup>	Normal operation (USB operates)	$I_{CC}^{*2}$	—	30	45	mA	f = 16 MHz, When PLL3 is used
				$V_{CC} = 3.3\text{ V } V_{CC} = 3.6\text{ V}$			
	Sleep mode		—	16	30	mA	f = 16 MHz, When USB and PLL are halted
				$V_{CC} = 3.3\text{ V } V_{CC} = 3.6\text{ V}$			
	All modules other than flash memory stopped		—	16	—	mA	f = 16 MHz (reference value)
				$V_{CC} = 3.3\text{ V}$			
	Subactive mode		—	45	180	$\mu\text{A}$	$V_{CC} = 3.3\text{ V}$ , EMLE = 0
				$30^{*5}$	—		
	Subsleep mode		—	35	100	$\mu\text{A}$	When crystal resonator (32.768 kHz) is used
				$20^{*5}$	—		
	Watch mode		—	5	40	$\mu\text{A}$	
	Standby mode* <sup>3</sup>			—	1.0	10	$\mu\text{A}$
				—	50	$50^\circ\text{C} < T_a$ 32.768 kHz RTC halted EMLE = 0	
Reference power supply current	During A/D conversion	$I_{CC}$	—	1.3	2.5	mA	$V_{ref} = 3.3\text{ V}$
	Idle		—	0.01	5.0		
RAM standby voltage		$V_{RAM}$	2.0	—	—	V	

Notes: If the A/D converter is not used, the Vref pin should not be open. Even if the A/D converter is not used, connect the Vref pin to Vcc.

1. Current dissipation values are for  $V_{IH \text{ min.}} = V_{CC} - 0.2 \text{ V}$  and  $V_{IL \text{ max.}} = 0.2 \text{ V}$ , with all output pins unloaded and the on-chip MOS pull-up transistors in the off state.
2.  $I_{CC}$  depends on  $V_{CC}$  and  $f$  as follows (Reference):  
 $I_{CC \text{ max.}} = 5 \text{ (mA)} + 0.52 \text{ (mA/(MHz} \times \text{V))} \times V_{CC} \times f$  (normal operation, USB halted)  
 $I_{CC \text{ max.}} = 9 \text{ (mA)} + 0.60 \text{ (mA/(MHz} \times \text{V))} \times V_{CC} \times f$  (normal operation, USB operated)  
 $I_{CC \text{ max.}} = 1 \text{ (mA)} + 0.51 \text{ (mA/(MHz} \times \text{V))} \times V_{CC} \times f$  (sleep mode)
3. The values are for  $V_{RAM} < V_{CC} < 2.7 \text{ V}$ ,  $V_{IH \text{ min.}} = V_{CC} \times 0.9$ , and  $V_{IL \text{ max.}} = 0.3 \text{ V}$ .
4. The FWE pin is effective only in the F-ZTAT version.
5. Reference value when setting the flash memory module stop mode is carried out while the on-chip RAM program is executed. The value is effective in the F-ZTAT version.

**Table 22.3 Permissible Output Currents**

Condition A:  $V_{CC} = \text{PLL } V_{CC} = \text{Dr } V_{CC} = 2.4 \text{ V to } 3.6 \text{ V}$ ,  $V_{\text{ref}} = 2.4 \text{ V to } V_{CC}$ ,  $V_{SS} = \text{PLL } V_{SS} = \text{Dr } V_{SS} = 0 \text{ V}$ ,  $f = 32.768 \text{ kHz, } 6 \text{ MHz}$ ,  $T_a = -20^\circ\text{C to } +75^\circ\text{C}$  (regular specifications),  $T_a = -40^\circ\text{C to } +85^\circ\text{C}$  (wide-range specifications)

Condition B:  $V_{CC} = \text{PLL } V_{CC} = \text{Dr } V_{CC} = 2.7 \text{ V to } 3.6 \text{ V}$ ,  $V_{\text{ref}} = 2.7 \text{ V to } V_{CC}$ ,  $V_{SS} = \text{PLL } V_{SS} = \text{Dr } V_{SS} = 0 \text{ V}$ ,  $f = 32.768 \text{ kHz, } 6 \text{ MHz to } 16 \text{ MHz}$ ,  $T_a = -20^\circ\text{C to } +75^\circ\text{C}$  (regular specifications),  $T_a = -40^\circ\text{C to } +85^\circ\text{C}$  (wide-range specifications)

Condition C:  $V_{CC} = \text{PLL } V_{CC} = \text{Dr } V_{CC} = 3.0 \text{ V to } 3.6 \text{ V}$ ,  $V_{\text{ref}} = 3.0 \text{ V to } V_{CC}$ ,  $V_{SS} = \text{PLL } V_{SS} = \text{Dr } V_{SS} = 0 \text{ V}$ ,  $f = 32.768 \text{ kHz, } 6 \text{ MHz to } 24 \text{ MHz}$ ,  $T_a = -20^\circ\text{C to } +75^\circ\text{C}$  (regular specifications),  $T_a = -40^\circ\text{C to } +85^\circ\text{C}$  (wide-range specifications)

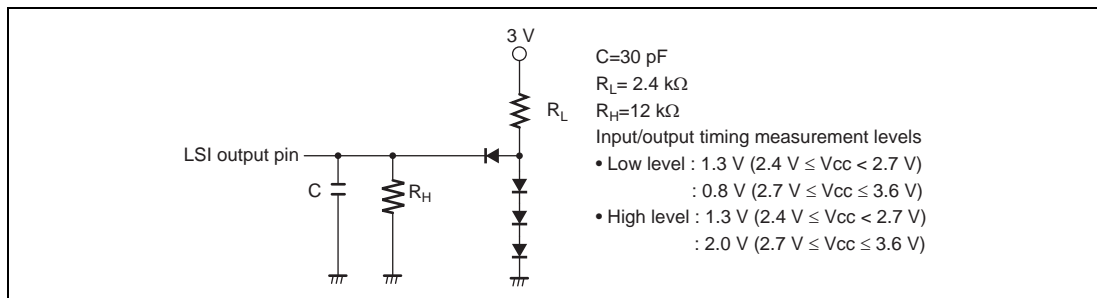
Condition D:  $V_{CC} = \text{PLL } V_{CC} = \text{Dr } V_{CC} = 3.0 \text{ V to } 3.6 \text{ V}$ ,  $V_{\text{ref}} = 3.0 \text{ V to } V_{CC}$ ,  $V_{SS} = \text{PLL } V_{SS} = \text{Dr } V_{SS} = 0 \text{ V}$ ,  $f = 32.768 \text{ kHz, } 16 \text{ MHz to } 24 \text{ MHz}$ ,  $T_a = -20^\circ\text{C to } +75^\circ\text{C}$  (regular specifications),  $T_a = -40^\circ\text{C to } +85^\circ\text{C}$  (wide-range specifications)

Item		Symbol	Min.	Typ.	Max.	Unit
Permissible output low current (per pin)	All output pins	$I_{OL}$	—	—	1.0	mA
Permissible output low current (total)	Total of all output pins	$\sum I_{OL}$	—	—	60	mA
Permissible output high current (per pin)	All output pins	$-I_{OH}$	—	—	1.0	mA
Permissible output high current (total)	Total of all output pins	$\sum -I_{OH}$	—	—	30	mA

Note: To protect chip reliability, do not exceed the output current values in table 22.3.

## 22.4 AC Characteristics

Figure 22.2 shows, the test conditions for the AC characteristics.



**Figure 22.2 Output Load Circuit**

## 22.4.1 Clock Timing

Table 22.4 lists the clock timing

**Table 22.4 Clock Timing**

Condition A:  $V_{CC} = PLL V_{CC} = Dr V_{CC} = 2.4 \text{ V to } 3.6 \text{ V}$ ,  $V_{ref} = 2.4 \text{ V to } V_{CC}$ ,  $V_{SS} = PLLV_{SS} = Dr V_{SS} = 0 \text{ V}$ ,  $f = 32.768 \text{ kHz, } 6 \text{ MHz}$ ,  $T_a = -20^\circ\text{C to } +75^\circ\text{C}$  (regular specifications),  $T_a = -40^\circ\text{C to } +85^\circ\text{C}$  (wide-range specifications)

Condition B:  $V_{CC} = PLL V_{CC} = Dr V_{CC} = 2.7 \text{ V to } 3.6 \text{ V}$ ,  $V_{ref} = 2.7 \text{ V to } V_{CC}$ ,  $V_{SS} = PLLV_{SS} = Dr V_{SS} = 0 \text{ V}$ ,  $f = 32.768 \text{ kHz, } 6 \text{ MHz to } 16 \text{ MHz}$ ,  $T_a = -20^\circ\text{C to } +75^\circ\text{C}$  (regular specifications),  $T_a = -40^\circ\text{C to } +85^\circ\text{C}$  (wide-range specifications)

Condition C:  $V_{CC} = PLL V_{CC} = Dr V_{CC} = 3.0 \text{ V to } 3.6 \text{ V}$ ,  $V_{ref} = 3.0 \text{ V to } V_{CC}$ ,  $V_{SS} = PLLV_{SS} = Dr V_{SS} = 0 \text{ V}$ ,  $f = 32.768 \text{ kHz, } 6 \text{ MHz to } 24 \text{ MHz}$ ,  $T_a = -20^\circ\text{C to } +75^\circ\text{C}$  (regular specifications),  $T_a = -40^\circ\text{C to } +85^\circ\text{C}$  (wide-range specifications)

Condition D:  $V_{CC} = PLL V_{CC} = Dr V_{CC} = 3.0 \text{ V to } 3.6 \text{ V}$ ,  $V_{ref} = 3.0 \text{ V to } V_{CC}$ ,  $V_{SS} = PLLV_{SS} = Dr V_{SS} = 0 \text{ V}$ ,  $f = 32.768 \text{ kHz, } 16 \text{ MHz to } 24 \text{ MHz}$ ,  $T_a = -20^\circ\text{C to } +75^\circ\text{C}$  (regular specifications),  $T_a = -40^\circ\text{C to } +85^\circ\text{C}$  (wide-range specifications)

Item	Symbol	Condition A		Condition B		Condition C		Condition D		Unit	Test Conditions
		Min.	Max.	Min.	Max.	Min.	Max.	Min.	Max.		
Clock cycle time	$t_{cyc}$	166.6	62.5	166.6	41.6	166.6	41.6	62.5	ns		
Clock high pulse width	$t_{CH}$	50	—	20	—	13	—	13	—	ns	
Clock low pulse width	$t_{CL}$	50	—	20	—	13	—	13	—	ns	
Clock rise time	$t_{Cr}$	—	25	—	10	—	7	—	7	ns	
Clock fall time	$t_{Cf}$	—	25	—	10	—	7	—	7	ns	
Oscillation stabilization time at reset (crystal)	$t_{OSC1}$	40	—	20	—	20	—	20	—	ms	Figure 22.4
Oscillation stabilization time in software standby (crystal)	$t_{OSC2}$	16	—	8	—	8	—	8	—	ms	Figures 20.4, 19.2 $C_{L1} = C_{L2} = 10 \text{ to } 22 \text{ pF}$
		16	—	8	—	4	—	4	—	ms	Figures 20.4, 19.2 $C_{L1} = C_{L2} = 10 \text{ to } 15 \text{ pF}$



Item	Symbol	Condition A		Condition B		Condition C		Condition D		Unit	Test Conditions
		Min.	Max.	Min.	Max.	Min.	Max.	Min.	Max.		
External clock output stabilization delay time	$t_{DEXT}$	1000	—	500	—	500	—	500	—	$\mu\text{s}$	Figure 22.4
Subclock stabilization time	$t_{OSC3}$	—	4	—	2	—	2	—	2	s	
Subclock oscillator frequency	$f_{SUB}$	32.768		32.768		32.768		32.768		kHz	
Subclock ( $\phi_{SUB}$ ) cycle time	$f_{SUB}$	30.5		30.5		30.5		30.5		$\mu\text{s}$	

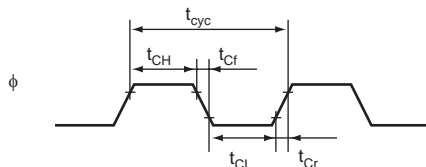


Figure 22.3 System Clock Timing

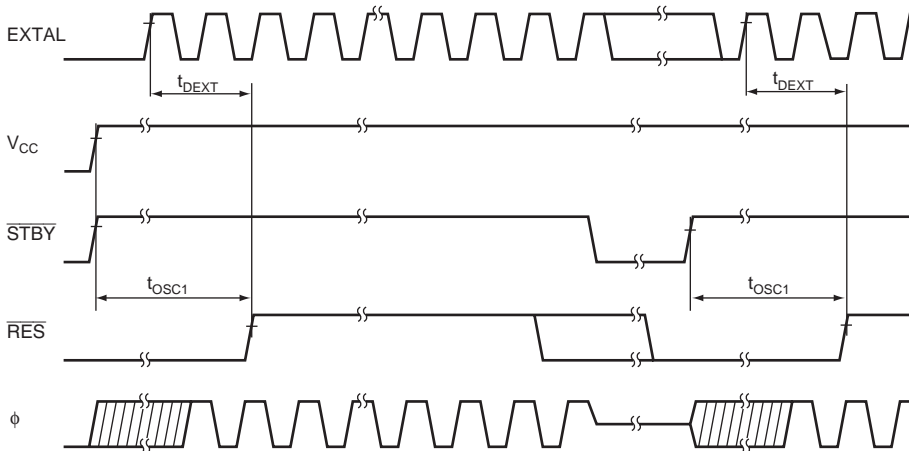


Figure 22.4 Oscillation Stabilization Timing

## 22.4.2 Control Signal Timing

Table 22.5 lists the control signal timing.

**Table 22.5 Control Signal Timing**

Condition A:  $V_{CC} = PLL V_{CC} = Dr V_{CC} = 2.4 \text{ V to } 3.6 \text{ V}$ ,  $V_{ref} = 2.4 \text{ V to } V_{CC}$ ,  $V_{SS} = PLL V_{SS} = Dr V_{SS} = 0 \text{ V}$ ,  $f = 32.768 \text{ kHz, } 6 \text{ MHz}$ ,  $T_a = -20^\circ\text{C to } +75^\circ\text{C}$  (regular specifications),  $T_a = -40^\circ\text{C to } +85^\circ\text{C}$  (wide-range specifications)

Condition B:  $V_{CC} = PLL V_{CC} = Dr V_{CC} = 2.7 \text{ V to } 3.6 \text{ V}$ ,  $V_{ref} = 2.7 \text{ V to } V_{CC}$ ,  $V_{SS} = PLL V_{SS} = Dr V_{SS} = 0 \text{ V}$ ,  $f = 32.768 \text{ kHz, } 6 \text{ MHz to } 16 \text{ MHz}$ ,  $T_a = -20^\circ\text{C to } +75^\circ\text{C}$  (regular specifications),  $T_a = -40^\circ\text{C to } +85^\circ\text{C}$  (wide-range specifications)

Condition C:  $V_{CC} = PLL V_{CC} = Dr V_{CC} = 3.0 \text{ V to } 3.6 \text{ V}$ ,  $V_{ref} = 3.0 \text{ V to } V_{CC}$ ,  $V_{SS} = PLL V_{SS} = Dr V_{SS} = 0 \text{ V}$ ,  $f = 32.768 \text{ kHz, } 6 \text{ MHz to } 24 \text{ MHz}$ ,  $T_a = -20^\circ\text{C to } +75^\circ\text{C}$  (regular specifications),  $T_a = -40^\circ\text{C to } +85^\circ\text{C}$  (wide-range specifications)

Condition D:  $V_{CC} = PLL V_{CC} = Dr V_{CC} = 3.0 \text{ V to } 3.6 \text{ V}$ ,  $V_{ref} = 3.0 \text{ V to } V_{CC}$ ,  $V_{SS} = PLL V_{SS} = Dr V_{SS} = 0 \text{ V}$ ,  $f = 32.768 \text{ kHz, } 16 \text{ MHz to } 24 \text{ MHz}$ ,  $T_a = -20^\circ\text{C to } +75^\circ\text{C}$  (regular specifications),  $T_a = -40^\circ\text{C to } +85^\circ\text{C}$  (wide-range specifications)

Item	Symbol	Condition A		Condition B, C, D		Unit	Test Conditions
		Min.	Max.	Min.	Max.		
$\overline{RES}$ setup time	$t_{RESS}$	350	—	250	—	ns	Figure 22.5
$\overline{RES}$ pulse width	$t_{RESW}$	20	—	20	—	$t_{cyc}$	
$\overline{MRES}$ setup time	$t_{MRESS}$	350	—	250	—	ns	Figure 22.6
$\overline{MRES}$ pulse width	$t_{MRESW}$	20	—	20	—	$t_{cyc}$	
NMI setup time	$t_{NMIS}$	350	—	250	—	ns	Figure 22.6
NMI hold time	$t_{NMIH}$	10	—	10	—	ns	
NMI pulse width (exiting software standby mode)	$t_{NMIW}$	300	—	200	—	ns	
$\overline{IRQ}$ setup time	$t_{IRQS}$	350	—	250	—	ns	
$\overline{IRQ}$ hold time	$t_{IRQH}$	10	—	10	—	ns	
$\overline{IRQ}$ pulse width (exiting software standby mode)	$t_{IRQW}$	300	—	200	—	ns	

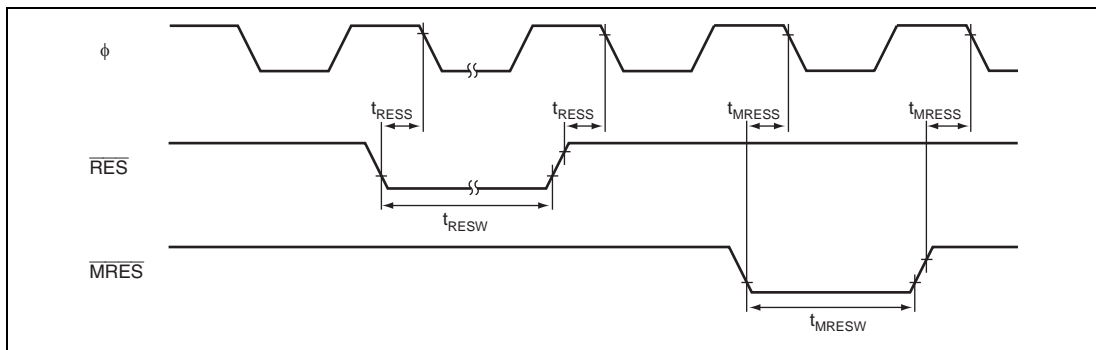


Figure 22.5 Reset Input Timing

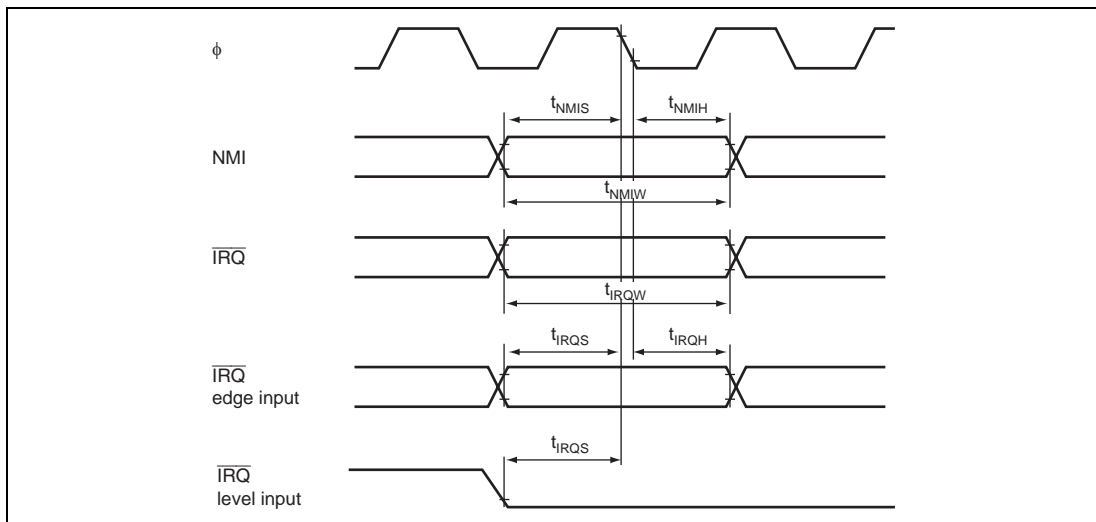


Figure 22.6 Interrupt Input Timing

### 22.4.3 Bus Timing

Table 22.6 shows, Bus Timing.

**Table 22.6 Bus Timing**

Condition A:  $V_{CC} = PLL V_{CC} = Dr V_{CC} = 2.4 \text{ V to } 3.6 \text{ V}$ ,  $V_{ref} = 2.4 \text{ V to } V_{CC}$ ,  $V_{SS} = PLL V_{SS} = Dr V_{SS} = 0 \text{ V}$ ,  $f = 32.768 \text{ kHz, } 6 \text{ MHz}$ ,  $T_a = -20^\circ\text{C to } +75^\circ\text{C}$  (regular specifications),  $T_a = -40^\circ\text{C to } +85^\circ\text{C}$  (wide-range specifications)

Condition B:  $V_{CC} = PLL V_{CC} = Dr V_{CC} = 2.7 \text{ V to } 3.6 \text{ V}$ ,  $V_{ref} = 2.7 \text{ V to } V_{CC}$ ,  $V_{SS} = PLL V_{SS} = Dr V_{SS} = 0 \text{ V}$ ,  $f = 32.768 \text{ kHz, } 6 \text{ MHz to } 16 \text{ MHz}$ ,  $T_a = -20^\circ\text{C to } +75^\circ\text{C}$  (regular specifications),  $T_a = -40^\circ\text{C to } +85^\circ\text{C}$  (wide-range specifications)

Condition C:  $V_{CC} = PLL V_{CC} = Dr V_{CC} = 3.0 \text{ V to } 3.6 \text{ V}$ ,  $V_{ref} = 3.0 \text{ V to } V_{CC}$ ,  $V_{SS} = PLL V_{SS} = Dr V_{SS} = 0 \text{ V}$ ,  $f = 32.768 \text{ kHz, } 6 \text{ MHz to } 24 \text{ MHz}$ ,  $T_a = -20^\circ\text{C to } +75^\circ\text{C}$  (regular specifications),  $T_a = -40^\circ\text{C to } +85^\circ\text{C}$  (wide-range specifications)

Condition D:  $V_{CC} = PLL V_{CC} = Dr V_{CC} = 3.0 \text{ V to } 3.6 \text{ V}$ ,  $V_{ref} = 3.0 \text{ V to } V_{CC}$ ,  $V_{SS} = PLL V_{SS} = Dr V_{SS} = 0 \text{ V}$ ,  $f = 32.768 \text{ kHz, } 16 \text{ MHz to } 24 \text{ MHz}$ ,  $T_a = -20^\circ\text{C to } +75^\circ\text{C}$  (regular specifications),  $T_a = -40^\circ\text{C to } +85^\circ\text{C}$  (wide-range specifications)

Item	Symbol	Condition A		Condition B		Condition C, D		Unit	Test Conditions
		Min.	Max.	Min.	Max.	Min.	Max.		
Address delay time	$t_{AD}$	—	90	—	50	—	30	ns	Figures 22.7, 22.8, 22.10
Address setup time	$t_{AS}$	$0.5 \times t_{cyc}$ - 60	—	$0.5 \times t_{cyc}$ - 30	—	$0.5 \times t_{cyc}$ - 20	—	ns	
Address hold time	$t_{AH}$	$0.5 \times t_{cyc}$ - 30	—	$0.5 \times t_{cyc}$ - 15	—	$0.5 \times t_{cyc}$ - 8	—	ns	
$\overline{CS}$ delay time	$t_{CSD}$	—	90	—	50	—	30	ns	Figures 22.7, 22.8
$\overline{AS}$ delay time	$t_{ASD}$	—	90	—	50	—	25	ns	Figures 22.7, 22.8, 22.10
$\overline{RD}$ delay time 1	$t_{RSD1}$	—	90	—	50	—	25	ns	Figures 22.7, 22.8
$\overline{RD}$ delay time 2	$t_{RSD2}$	—	90	—	50	—	25	ns	Figures 22.7, 22.8, 22.10
Read data setup time	$t_{RDS}$	50	—	30	—	20	—	ns	
Read data hold time	$t_{RDH}$	0	—	0	—	0	—	ns	
Read data access time 2	$t_{ACC2}$	—	$1.5 \times t_{cyc}$ - 90	—	$1.5 \times t_{cyc}$ - 65	—	$1.5 \times t_{cyc}$ - 35	ns	Figure 22.7

Item	Symbol	Condition A		Condition B		Condition C, D		Unit	Test Conditions
		Min.	Max.	Min.	Max.	Min.	Max.		
Read data access time 3	$t_{ACC3}$	—	$2.0 \times t_{cyc}$ – 90	—	$2.0 \times t_{cyc}$ – 65	—	$2.0 \times t_{cyc}$ – 40	ns	Figures 22.7, 22.10
Read data access time 4	$t_{ACC4}$	—	$2.5 \times t_{cyc}$ – 90	—	$2.5 \times t_{cyc}$ – 65	—	$2.5 \times t_{cyc}$ – 35	ns	Figure 22.8
Read data access time 5	$t_{ACC5}$	—	$3.0 \times t_{cyc}$ – 90	—	$3.0 \times t_{cyc}$ – 65	—	$3.0 \times t_{cyc}$ – 40	ns	
$\overline{WR}$ delay time 1	$t_{WRD1}$	—	90	—	50	—	20	ns	Figure 22.8
$\overline{WR}$ delay time 2	$t_{WRD2}$	—	90	—	50	—	25	ns	Figures 22.7, 22.8
$\overline{WR}$ pulse width 1	$t_{WSW1}$	$1.0 \times t_{cyc}$ – 60	—	$1.0 \times t_{cyc}$ – 30	—	$1.0 \times t_{cyc}$ – 20	—	ns	Figure 22.7
$\overline{WR}$ pulse width 2	$t_{WSW2}$	$1.5 \times t_{cyc}$ – 60	—	$1.5 \times t_{cyc}$ – 30	—	$1.5 \times t_{cyc}$ – 20	—	ns	Figure 22.8
Write data delay time	$t_{WDD}$	—	100	—	50	—	30	ns	Figures 22.7, 22.8
Write data setup time	$t_{WDS}$	$0.5 \times t_{cyc}$ – 80	—	$0.5 \times t_{cyc}$ – 30	—	$0.5 \times t_{cyc}$ – 20	—	ns	Figure 22.8
Write data hold time	$t_{WDH}$	$0.5 \times t_{cyc}$ – 60	—	$0.5 \times t_{cyc}$ – 15	—	$0.5 \times t_{cyc}$ – 10	—	ns	Figures 22.7, 22.8
$\overline{WAIT}$ setup time	$t_{WTS}$	90	—	50	—	25	—	ns	Figure 22.9
$\overline{WAIT}$ hold time	$t_{WTH}$	10	—	10	—	5	—	ns	
$\overline{BREQ}$ setup time	$t_{BRQS}$	90	—	50	—	25	—	ns	Figure 22.11
$\overline{BACK}$ delay time	$t_{BACD}$	—	90	—	50	—	35	ns	
Bus-floating time	$t_{BZD}$	—	160	—	80	—	50	ns	

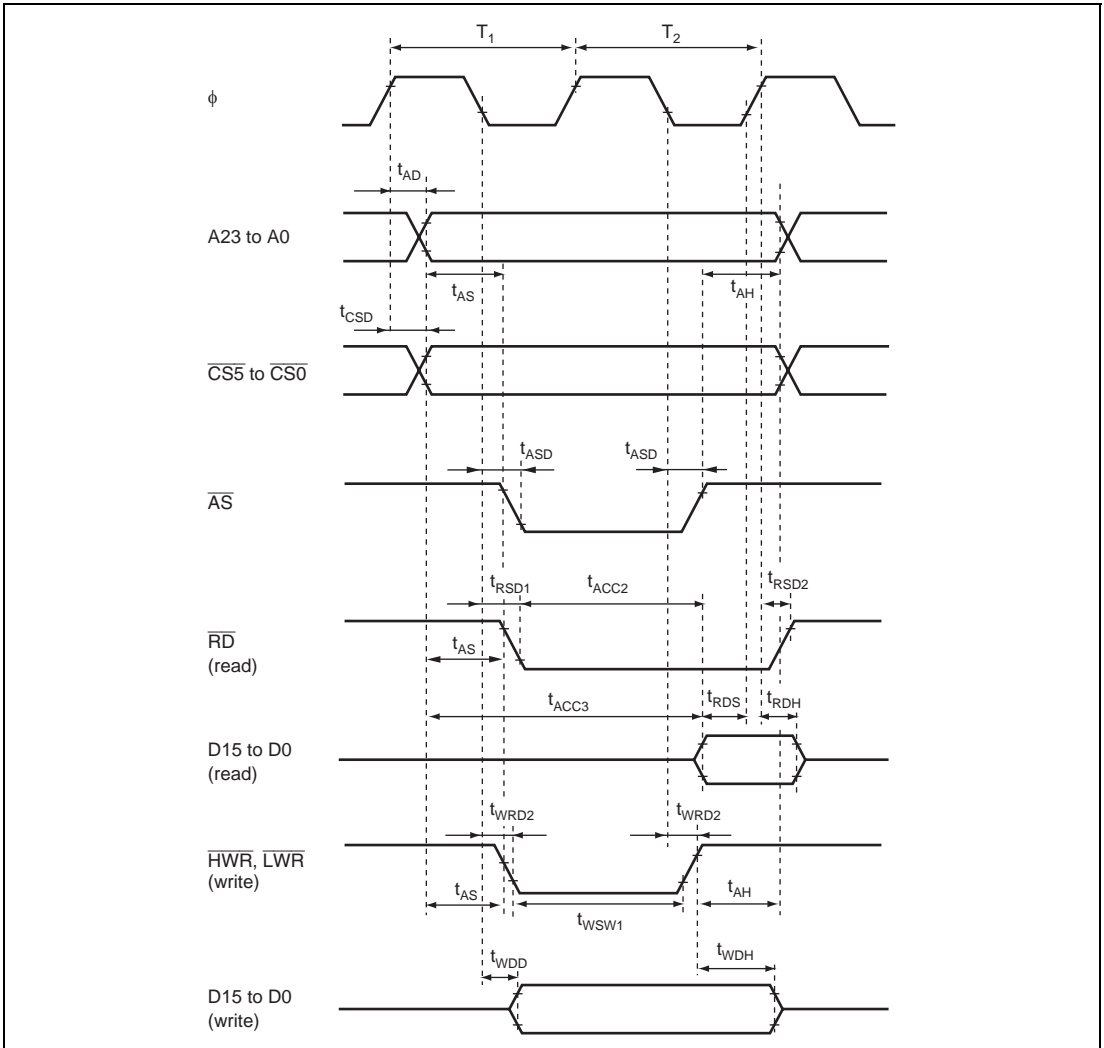


Figure 22.7 Basic Bus Timing (Two-State Access)

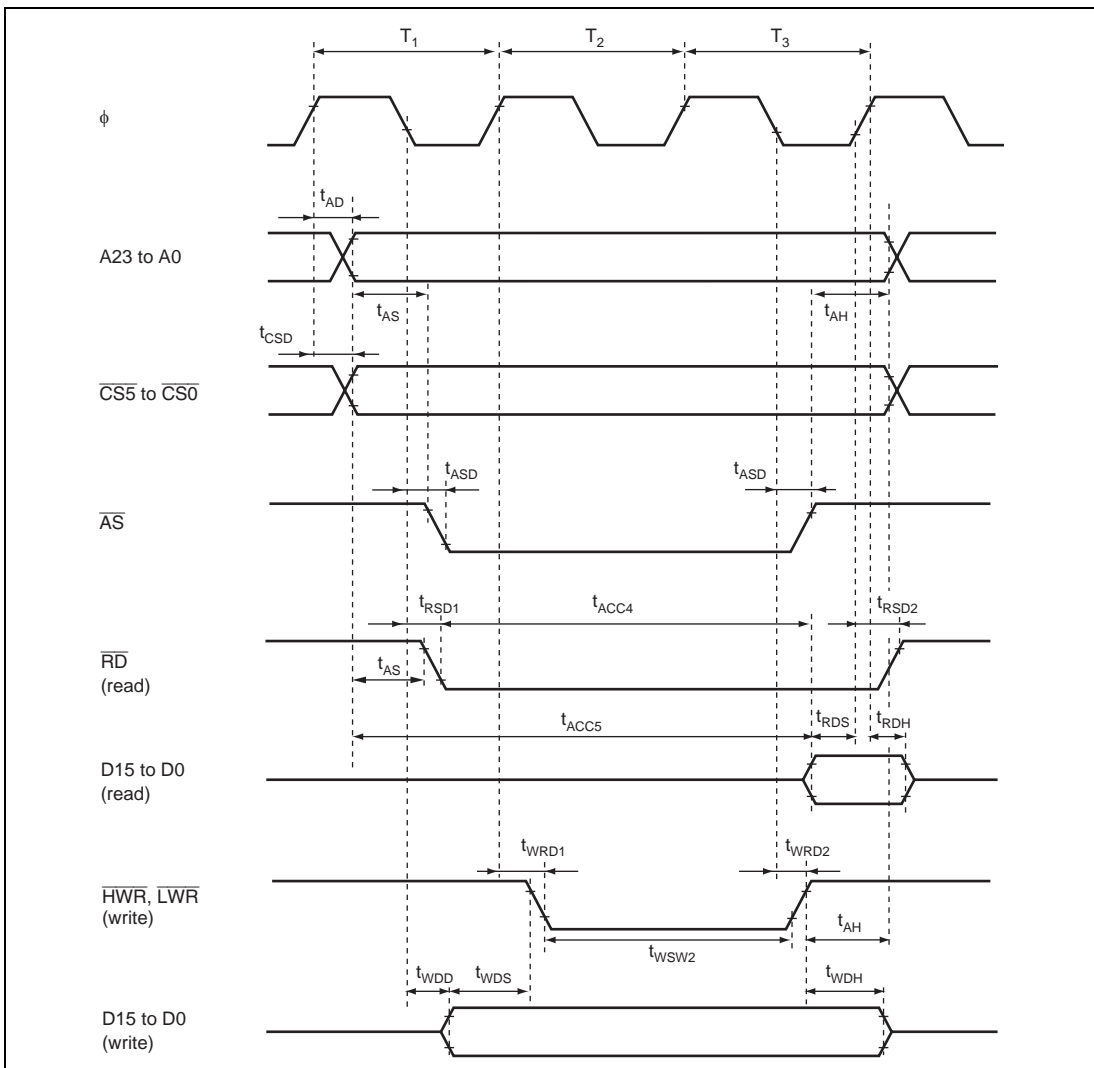
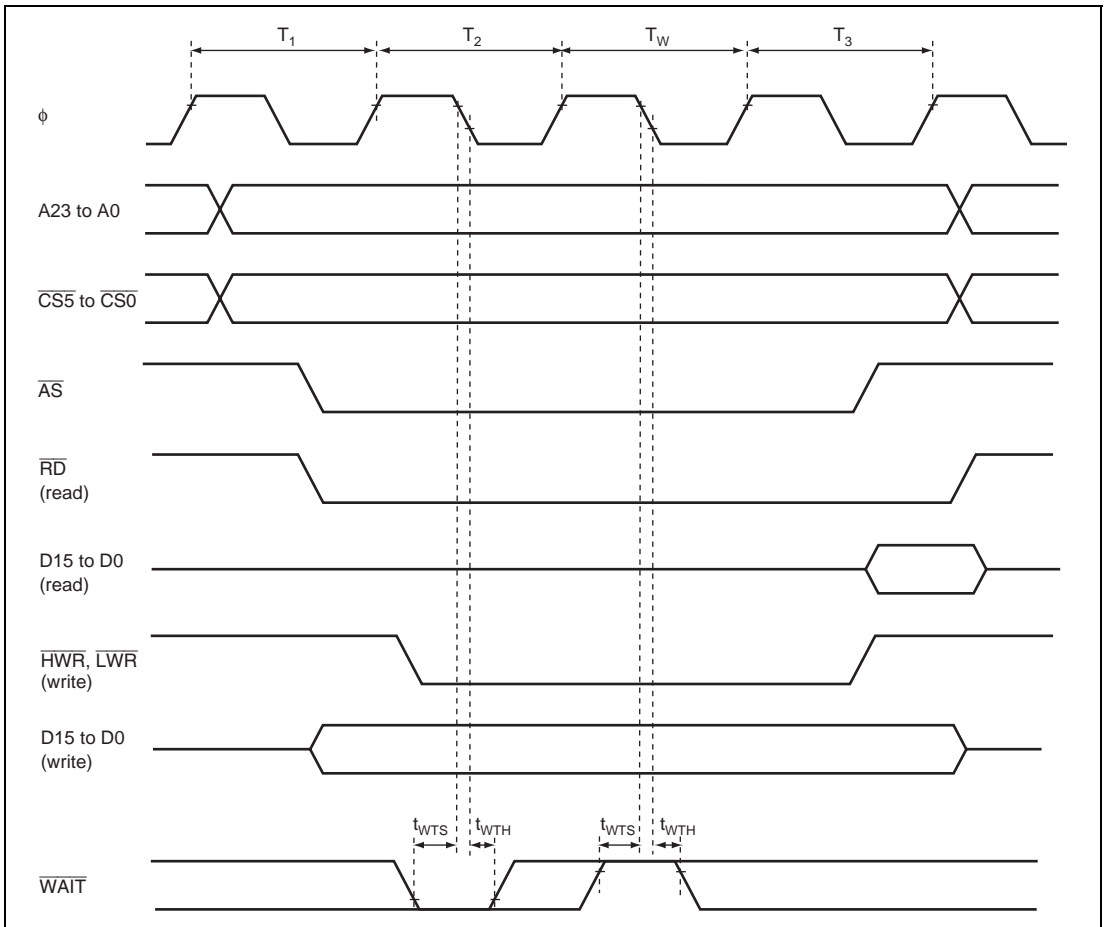
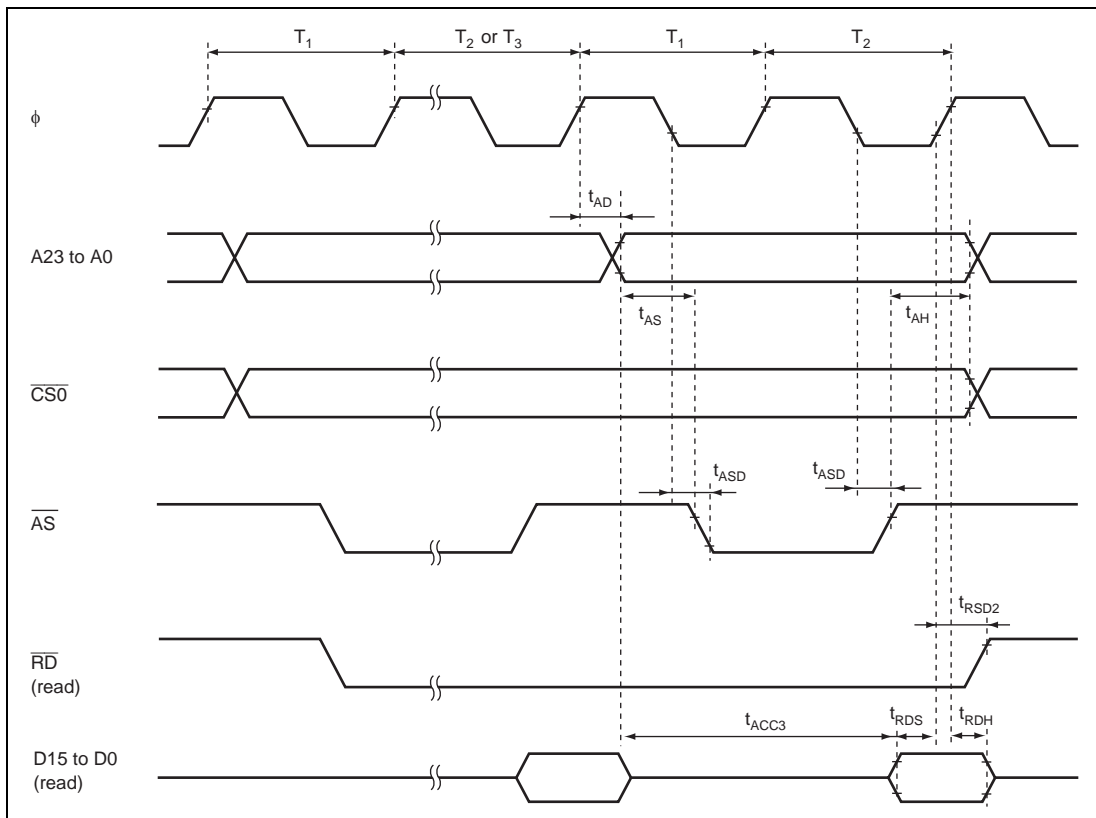


Figure 22.8 Basic Bus Timing (Three-State Access)



**Figure 22.9 Basic Bus Timing (Three-State Access with One Wait State)**





**Figure 22.10 Burst ROM Access Timing (Two-State Access)**

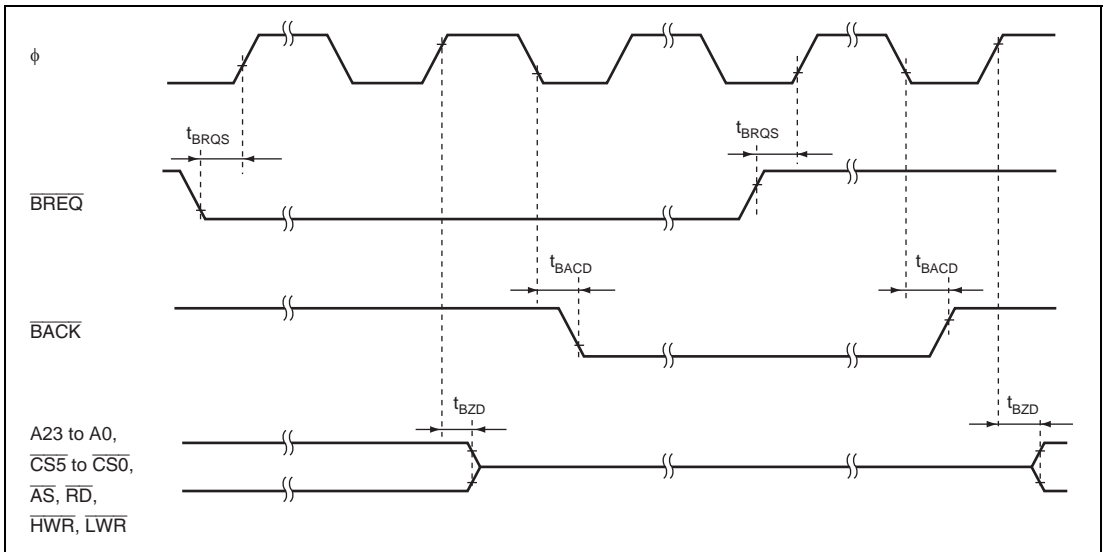


Figure 22.11 External Bus Release Timing

## 22.4.4 Timing of On-Chip Supporting Modules

Table 22.7 lists the timing of on-chip supporting modules.

**Table 22.7 Timing of On-Chip Supporting Modules**

Condition A:  $V_{CC} = PLL V_{CC} = Dr V_{CC} = 2.4 \text{ V to } 3.6 \text{ V}$ ,  $V_{ref} = 2.4 \text{ V to } V_{CC}$ ,  $V_{SS} = PLLV_{SS} = Dr V_{SS} = 0 \text{ V}$ ,  $f = 32.768 \text{ kHz, } 6 \text{ MHz}$ ,  $T_a = -20^\circ\text{C to } +75^\circ\text{C}$  (regular specifications),  $T_a = -40^\circ\text{C to } +85^\circ\text{C}$  (wide-range specifications)

Condition B:  $V_{CC} = PLL V_{CC} = Dr V_{CC} = 2.7 \text{ V to } 3.6 \text{ V}$ ,  $V_{ref} = 2.7 \text{ V to } V_{CC}$ ,  $V_{SS} = PLLV_{SS} = Dr V_{SS} = 0 \text{ V}$ ,  $f = 32.768 \text{ kHz, } 6 \text{ MHz to } 16 \text{ MHz}$ ,  $T_a = -20^\circ\text{C to } +75^\circ\text{C}$  (regular specifications),  $T_a = -40^\circ\text{C to } +85^\circ\text{C}$  (wide-range specifications)

Condition C:  $V_{CC} = PLL V_{CC} = Dr V_{CC} = 3.0 \text{ V to } 3.6 \text{ V}$ ,  $V_{ref} = 3.0 \text{ V to } V_{CC}$ ,  $V_{SS} = PLLV_{SS} = Dr V_{SS} = 0 \text{ V}$ ,  $f = 32.768 \text{ kHz, } 6 \text{ MHz to } 24 \text{ MHz}$ ,  $T_a = -20^\circ\text{C to } +75^\circ\text{C}$  (regular specifications),  $T_a = -40^\circ\text{C to } +85^\circ\text{C}$  (wide-range specifications)

Condition D:  $V_{CC} = PLL V_{CC} = Dr V_{CC} = 3.0 \text{ V to } 3.6 \text{ V}$ ,  $V_{ref} = 3.0 \text{ V to } V_{CC}$ ,  $V_{SS} = PLLV_{SS} = Dr V_{SS} = 0 \text{ V}$ ,  $f = 32.768 \text{ kHz, } 16 \text{ MHz to } 24 \text{ MHz}$ ,  $T_a = -20^\circ\text{C to } +75^\circ\text{C}$  (regular specifications),  $T_a = -40^\circ\text{C to } +85^\circ\text{C}$  (wide-range specifications)

Item	Symbol	Condition A				Condition B				Condition C, D				Test Conditions
		Min.	Max.	Min.	Max.	Min.	Max.	Min.	Max.	Min.	Max.	Unit		
I/O port	Output data delay time	$t_{PWD}$	—	150	—	60	—	40	ns	Figure 22.12				
	Input data setup time	$t_{PRS}$	80	—	50	—	30	—						
	Input data hold time	$t_{PRH}$	50	—	50	—	30	—						
TPU	Timer output delay time	$t_{TOCD}$	—	150	—	60	—	40	ns	Figure 22.13				
	Timer input setup time	$t_{TICS}$	60	—	40	—	30	—						
	Timer clock input setup time	$t_{TCKS}$	60	—	40	—	30	—	ns	Figure 22.14				
	Timer clock pulse width	Single edge	$t_{TCKWH}$	1.5	—	1.5	—	1.5	—	$t_{cyc}$				
Both edges		$t_{TCKWL}$	2.5	—	2.5	—	2.5	—						

Item	Symbol	Condition A		Condition B		Condition C,D		Unit	Test Conditions		
		Min.	Max.	Min.	Max.	Min.	Max.				
SCI	Input clock cycle	Asynchronous	$t_{SCYC}$	4	—	4	—	4	—	$t_{CYC}$	Figure 22.15
		Synchronous		6	—	6	—	6	—		
	Input clock pulse width	$t_{SCKW}$	0.4	0.6	0.4	0.6	0.4	0.6	$t_{SCYC}$		
	Input clock rise time	$t_{SCKr}$	—	1.5	—	1.5	—	1.5	$t_{CYC}$		
	Input clock fall time	$t_{SCKf}$	—	1.5	—	1.5	—	1.5			
	Transmit data delay time	$t_{TXD}$	—	150	—	60	—	40	ns	Figure 22.16	
	Receive data setup time (synchronous)	$t_{RXS}$	150	—	60	—	40	—			
	Receive data hold time (synchronous)	$t_{RXH}$	150	—	60	—	40	—			
A/D converter	Trigger input setup time	$t_{TRGS}$	60	—	40	—	30	—	ns	Figure 22.17	
Boundary scan	TCK cycle time	$t_{TCYC}$	166.6	—	62.5	—	41.6	—	ns	Figure 22.18	
	TCK high level pulse width	$t_{TCKH}$	0.4	0.6	0.4	0.6	0.4	0.6	$t_{TCYC}$		
	TCK low level pulse width	$t_{TCKL}$	0.4	0.6	0.4	0.6	0.4	0.6	$t_{TCYC}$		
	TRST pulse width	$t_{TRSW}$	20	—	20	—	20	—	$t_{TCYC}$	Figure 22.19	
	TRST setup time	$t_{TRSS}$	350	—	250	—	250	—	ns		
	TDI setup time	$t_{TDIS}$	80	—	30	—	20	—	ns	Figure 22.20	
	TDI hold time	$t_{TDIH}$	10	—	10	—	10	—			
	TMS setup time	$t_{TMSS}$	80	—	30	—	20	—			
TMS hold time	$t_{TMSH}$	10	—	10	—	10	—				
TDO delay time	$t_{TDOD}$	—	100	—	40	—	35				

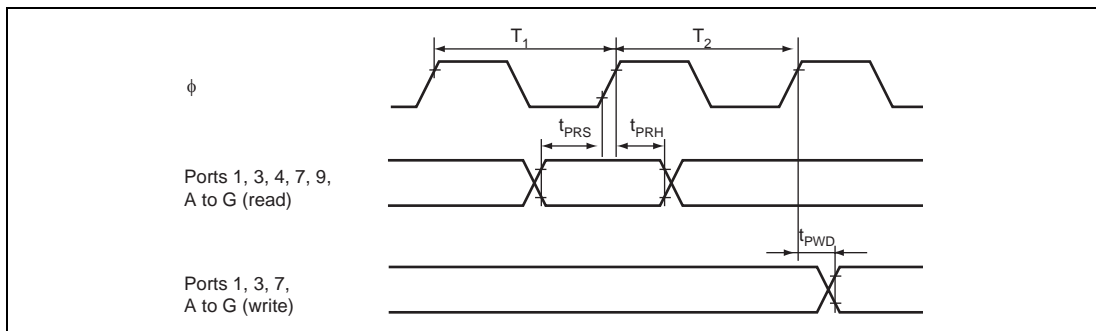


Figure 22.12 I/O Port Input/Output Timing

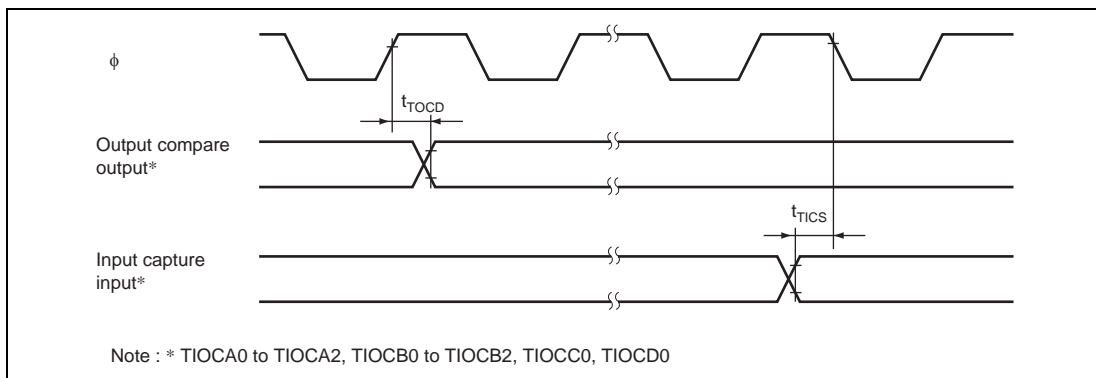


Figure 22.13 TPU Input/Output Timing

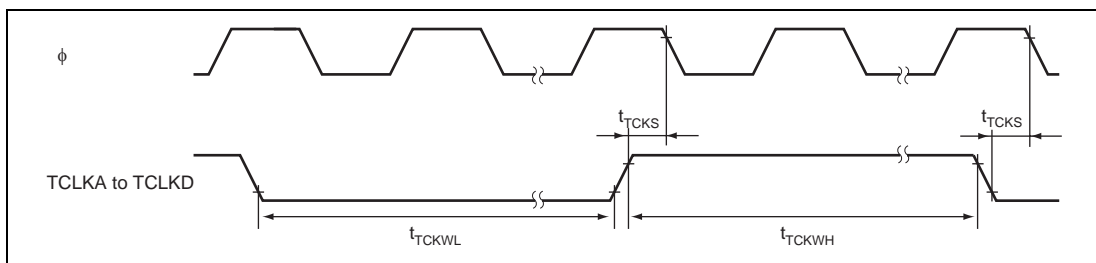
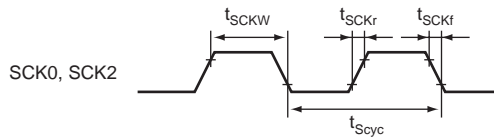
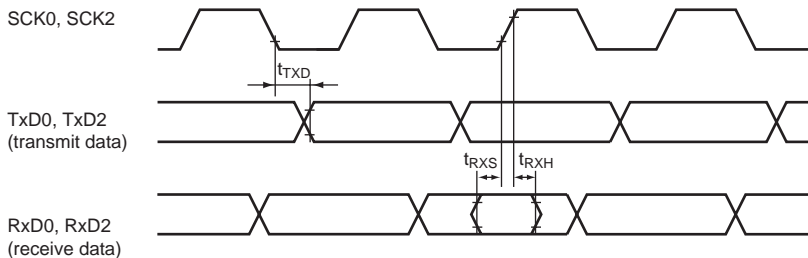


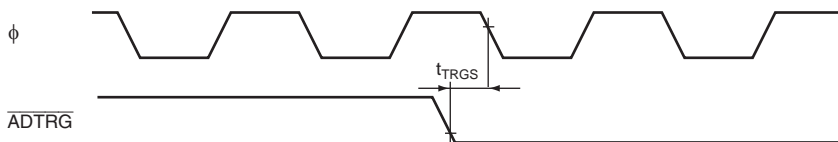
Figure 22.14 TPU Clock Input Timing



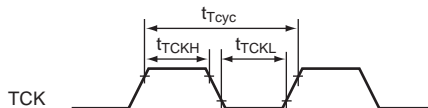
**Figure 22.15 SCK Clock Input Timing**



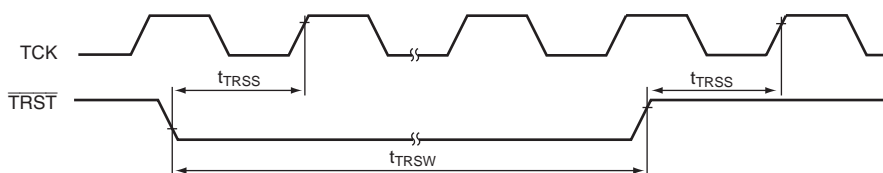
**Figure 22.16 SCI Input/Output Timing (Clock Synchronous Mode)**



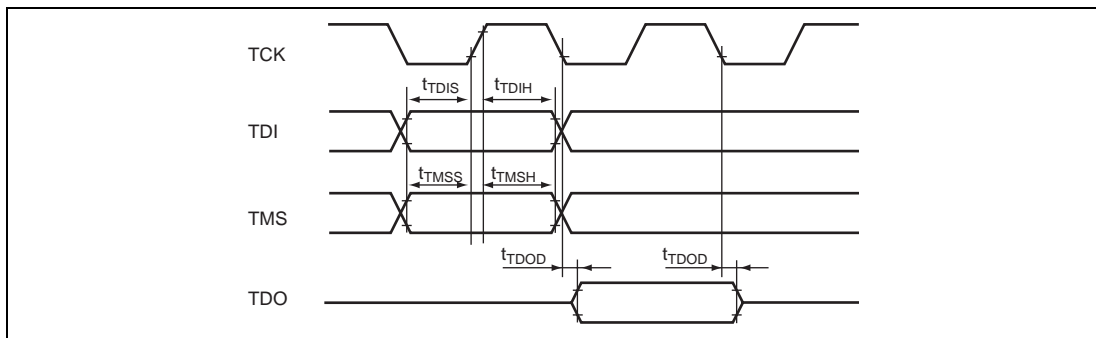
**Figure 22.17 A/D Converter External Trigger Input Timing**



**Figure 22.18 Boundary Scan TCK Input Timing**



**Figure 22.19 Boundary Scan  $\overline{TRST}$  Input Timing (At Reset Hold)**



**Figure 22.20 Boundary Scan Data Transmission Timing**

## 22.5 USB Characteristics

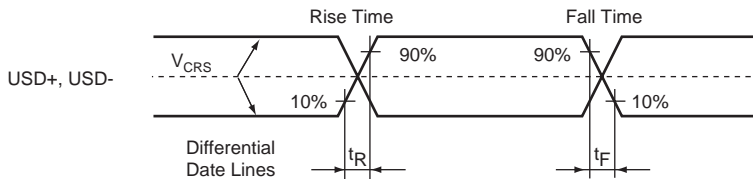
Table 22.8 lists the USB characteristics (USD+ and USD- pins) when the on-chip USB transceiver is used.

**Table 22.8 USB Characteristics (USD+ and USD- pins) when On-Chip USB Transceiver Is Used**

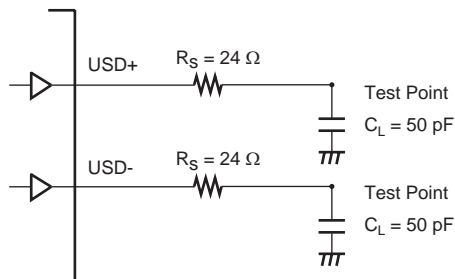
Conditions:  $V_{CC} = PLL V_{CC} = Dr V_{CC} = 3.0 \text{ V to } 3.6 \text{ V}$ ,  $V_{SS} = PLL V_{SS} = Dr V_{SS} = 0 \text{ V}$ ,  $f = 16 \text{ MHz, } 24 \text{ MHz}$ ,  $T_a = -20^\circ\text{C to } +75^\circ\text{C}$  (regular specifications),  $T_a = -40^\circ\text{C to } +85^\circ\text{C}$  (wide-range specifications)

Item	Symbol	Min.	Max.	Unit	Test Condition
Input characteristics	Input high level voltage $V_{IH}$	2.0	—	V	
	Input low level voltage $V_{IL}$	—	0.8	V	
	Differential input sense $V_{DI}$	0.2	—	V	(D+)-(D-)
	Differential common mode range $V_{CM}$	0.8	2.5	V	
Output characteristics	Output high level voltage $V_{OH}$	2.8	—	V	$I_{OH} = -200 \mu\text{A}$
	Output low level voltage $V_{OL}$	—	0.3	V	$I_{OL} = 2 \text{ mA}$
	Crossover voltage $V_{CRS}$	1.3	2.0	V	
	Rise time $t_R$	4	20	ns	
	Fall time $t_F$	4	20	ns	
	Rise time/fall time matching $t_{RFM}$	90	111.11	%	$(T_R/T_F)$
	Output resistance $Z_{DRV}$	28	44	$\Omega$	Including $R_s = 24 \Omega$





**Figure 22.21 Data Signal Timing**



**Figure 22.22 Test Load Circuit**

## 22.6 A/D Conversion Characteristics

Table 22.9 lists the A/D conversion characteristics.

**Table 22.9 A/D Conversion Characteristics**

Condition A:  $V_{CC} = PLL V_{CC} = Dr V_{CC} = 2.4 \text{ V to } 3.6 \text{ V}$ ,  $V_{ref} = 2.4 \text{ V to } V_{CC}$ ,  $V_{SS} = PLL V_{SS} = Dr V_{SS} = 0 \text{ V}$ ,  $f = 32.768 \text{ kHz, } 6 \text{ MHz}$ ,  $T_a = -20^\circ\text{C to } +75^\circ\text{C}$  (regular specifications),  $T_a = -40^\circ\text{C to } +85^\circ\text{C}$  (wide-range specifications)

Condition B:  $V_{CC} = PLL V_{CC} = Dr V_{CC} = 2.7 \text{ V to } 3.6 \text{ V}$ ,  $V_{ref} = 2.7 \text{ V to } V_{CC}$ ,  $V_{SS} = PLL V_{SS} = Dr V_{SS} = 0 \text{ V}$ ,  $f = 32.768 \text{ kHz, } 6 \text{ MHz to } 16 \text{ MHz}$ ,  $T_a = -20^\circ\text{C to } +75^\circ\text{C}$  (regular specifications),  $T_a = -40^\circ\text{C to } +85^\circ\text{C}$  (wide-range specifications)

Condition C:  $V_{CC} = PLL V_{CC} = Dr V_{CC} = 3.0 \text{ V to } 3.6 \text{ V}$ ,  $V_{ref} = 3.0 \text{ V to } V_{CC}$ ,  $V_{SS} = PLL V_{SS} = Dr V_{SS} = 0 \text{ V}$ ,  $f = 32.768 \text{ kHz, } 6 \text{ MHz to } 24 \text{ MHz}$ ,  $T_a = -20^\circ\text{C to } +75^\circ\text{C}$  (regular specifications),  $T_a = -40^\circ\text{C to } +85^\circ\text{C}$  (wide-range specifications)

Condition D:  $V_{CC} = PLL V_{CC} = Dr V_{CC} = 3.0 \text{ V to } 3.6 \text{ V}$ ,  $V_{ref} = 3.0 \text{ V to } V_{CC}$ ,  $V_{SS} = PLL V_{SS} = Dr V_{SS} = 0 \text{ V}$ ,  $f = 32.768 \text{ kHz, } 16 \text{ MHz to } 24 \text{ MHz}$ ,  $T_a = -20^\circ\text{C to } +75^\circ\text{C}$  (regular specifications),  $T_a = -40^\circ\text{C to } +85^\circ\text{C}$  (wide-range specifications)

Item	Condition A			Condition B, C, D			Unit
	Min.	Typ.	Max.	Min.	Typ.	Max.	
Resolution	10	10	10	10	10	10	bits
Conversion time	21.8	—	—	8.1	—	—	$\mu\text{s}$
Analog input capacitance	—	—	20	—	—	20	pF
Permissible signal-source impedance	—	—	5	—	—	5	k $\Omega$
Nonlinearity error	—	—	$\pm 6.0$	—	—	$\pm 6.0$	LSB
Offset error	—	—	$\pm 4.0$	—	—	$\pm 4.0$	LSB
Full-scale error	—	—	$\pm 4.0$	—	—	$\pm 4.0$	LSB
Quantization	—	—	$\pm 0.5$	—	—	$\pm 0.5$	LSB
Absolute accuracy	—	—	$\pm 8.0$	—	—	$\pm 6.0$	LSB

## 22.7 Flash Memory Characteristics

Table 22.10 lists the flash memory characteristics.

**Table 22.10 Flash Memory Characteristics**

Conditions:  $V_{CC} = PLLV_{CC} = DrV_{CC} = 3.0\text{ V to }3.6\text{ V}$ ,  $V_{ref} = 2.7\text{ V to }V_{CC}$ ,  
 $V_{SS} = PLLV_{SS} = DrV_{SS} = 0\text{ V}$ ,  
 $T_a = -20\text{ to }+75^{\circ}\text{C}$  (Programming/erasing operating temperature range)

Item	Symbol	Min.	Typ.	Max.	Unit	
Programming time* <sup>1</sup> * <sup>2</sup> * <sup>4</sup>	$t_P$	—	10	200	ms/128 bytes	
Erase time* <sup>1</sup> * <sup>3</sup> * <sup>5</sup>	$t_E$	—	50	1000	ms/block	
Reprogramming count	$N_{WEC}$	100* <sup>6</sup>	10000* <sup>7</sup>	—	Times	
Data retention time* <sup>8</sup>	$t_{DRP}$	10	—	—	Years	
Programming	Wait time after PSU1 bit setting* <sup>1</sup>	$y$	50	50	—	$\mu\text{s}$
	Wait time after P1 bit setting* <sup>1</sup> * <sup>4</sup>	$z0$	28	30	32	$\mu\text{s}$
		$z1$	198	200	202	$\mu\text{s}$
		$z2$	8	10	12	$\mu\text{s}$
		Wait time after P1 bit clear* <sup>1</sup>	$\alpha$	5	5	—
	Wait time after PSU1 bit clear* <sup>1</sup>	$\beta$	5	5	—	$\mu\text{s}$
	Wait time after PV1 bit setting* <sup>1</sup>	$\gamma$	4	4	—	$\mu\text{s}$
	Wait time after H'FF dummy write* <sup>1</sup>	$\varepsilon$	2	2	—	$\mu\text{s}$
	Wait time after PV1 bit clear* <sup>1</sup>	$\eta$	2	2	—	$\mu\text{s}$
	Maximum programming count* <sup>1</sup> * <sup>4</sup>	$N1$	—	—	6* <sup>4</sup>	Times
		$N2$	—	—	994* <sup>4</sup>	Times
	Common	Wait time after SWE1 bit setting* <sup>1</sup>	$x$	1	1	—
Wait time after SWE1 bit clear* <sup>1</sup>		$\theta$	100	100	—	$\mu\text{s}$
Erase	Wait time after ESU1 bit setting* <sup>1</sup>	$y$	100	100	—	$\mu\text{s}$
	Wait time after E1 bit setting* <sup>1</sup> * <sup>5</sup>	$z$	10	10	100	ms
	Wait time after E1 bit clear* <sup>1</sup>	$\alpha$	10	10	—	$\mu\text{s}$
	Wait time after ESU1 bit clear* <sup>1</sup>	$\beta$	10	10	—	$\mu\text{s}$
	Wait time after EV1 bit setting* <sup>1</sup>	$\gamma$	20	20	—	$\mu\text{s}$
	Wait time after H'FF dummy write* <sup>1</sup>	$\varepsilon$	2	2	—	$\mu\text{s}$
	Wait time after EV1 bit clear* <sup>1</sup>	$\eta$	4	4	—	$\mu\text{s}$
	Maximum erase count* <sup>1</sup> * <sup>5</sup>	$N$	—	—	100	Times

Notes: 1. Make each time setting in accordance with the program/program-verify flowchart or erase/erase-verify flowchart.

2. Programming time per 128 bytes (Shows the total period for which the P-bit in the flash memory control register (FLMCR1) is set. It does not include the programming verification time.)

3. Block erase time (Shows the total period for which the E1-bit FLMCR1 is set. It does not include the erase verification time.)
4. Maximum programming time value
$$t_p (\text{max.}) = \text{Wait time after P1 bit set (z)} \times \text{maximum programming count (N1 + N2)}$$
$$= (Z0 + Z2) \times 6 + Z1 \times 994$$
5. Maximum erasure time value
$$t_E (\text{max.}) = \text{Wait time after E1 bit set (z)} \times \text{maximum erasure count (N)}$$
6. Minimum times that guarantee all characteristics after programming. (The guaranteed range is 1 to the minimum value.)
7. Reference value when the temperature is 25°C. (It is reference that reprogramming is normally enabled up to this value.)
8. Data hold characteristics when reprogramming is performed within the range of specifications including the minimum value.

## 22.8 Usage Note

**General Notice during Design for Printed Circuit Board:** Measures for radiation noise caused by the transient current in this LSI should be taken into consideration. The examples of the measures are shown below.

- To use a multilayer printed circuit board which includes layers for Vcc and GND.
- To mount by-pass capacitors (approximately 0.1  $\mu\text{F}$ ) between the Vcc and GND (Vss) pins, and the PLLVcc and PLLGND pins, of this LSI.

**Characteristics of F-ZTAT and Masked ROM Versions:** Though the F-ZTAT version and the masked ROM version satisfy electrical characteristics described in this manual, the actual value of electrical characteristics, operating margin, and noise margin may differ due to the differences of production process, on-chip ROM, and layout patterning.

When the system has been evaluated with the F-ZTAT version, the equivalent evaluation should be implemented to the masked ROM version when shifted to the masked ROM version.

# Appendix

## A. I/O Port States in Each Processing State

Port Name Pin Name	MCU			Hardware Standby Mode	Software	Bus Right Release State	Program Execution State or Sleep Mode
	Operating Mode	Power-on Reset	Manual Reset		Standby Mode or Watch Mode		
P17 to P14	4 to 7	T	keep	T	keep	keep	I/O port
P13/A23 P12/A22 P11/A21	7	T	keep	T	keep	keep	I/O port
Address output selected by AEn bit	4 to 6	T	keep	T	[OPE=0] T [OPE=1] keep	T	Address output
Port selection	4 to 6	T	keep	T	keep	keep	I/O port
P10/A20	7	T	keep	T	keep	keep	I/O port
Address output selected by AEn bit	4 and 5	L	keep	T	[OPE=0] T [OPE=1] keep	T	Address output
Port selection	6	T					
Port selection	4 to 6	T* <sup>1</sup>	keep	T	keep	keep	I/O port
Port 3	4 to 7	T	keep	T	keep	keep	I/O port
Port 4	4 to 7	T	T	T	T	T	Input port
P77 to P75* <sup>3</sup>	7	T	keep	T	keep	keep	I/O port
P74* <sup>2</sup>	4 to 7	T	keep	T	keep	keep	I/O port
P71/ $\overline{CS5}$ * <sup>2</sup>	7	T	keep	T	keep	keep	I/O port
P70/ $\overline{CS4}$ * <sup>2</sup>	4 to 6	T	keep	T	[DDR•OPE=0] T [DDR•OPE=1] H	T	[DDR=0] Input port [DDR=1] $\overline{CS5}$ , $\overline{CS4}$
Port 9	4 to 7	T	T	T	[DAOEn=1] keep [DAOEn=0] T	keep	Input port

# Appendix

Port Name Pin Name	MCU			Hardware Standby Mode	Software		Program Execution State or Sleep Mode
	Operating Mode	Power-on Reset	Manual Reset		Standby Mode or Watch Mode	Bus Right Release State	
Port A	7	T	keep	T	keep	keep	I/O port
Address output selected by AEn bit	4 and 5	L	keep	T	[OPE=0] T	T	Address output
	6	T			[OPE=1] keep		
Port selection	4 to 6	T* <sup>1</sup>	keep	T	keep	keep	I/O port
Port B* <sup>2</sup>	7	T	keep	T	keep	keep	I/O port
Address output selected by AEn bit	4 and 5	L	keep	T	[OPE=0] T	T	Address output
	6	T			[OPE=1] keep		
Port selection	4 to 6	T* <sup>1</sup>	keep	T	keep	keep	I/O port
Port C* <sup>2</sup>	4 and 5	L	keep	T	[OPE=0] T	T	Address output
					[OPE=1] keep		
	6	T	keep	T	[DDR•OPE=0] T	T	[DDR=0] Input port
					[DDR•OPE=1] keep		[DDR=1] Address output
	7	T	keep	T	keep	keep	I/O port
Port D* <sup>2</sup>	4 to 6	T	T	T	T	T	Data bus
	7	T	keep	T	keep	keep	I/O port
Port E	8-bit bus	4 to 6	T	keep	T	keep	I/O port
	16-bit bus	4 to 6	T	T	T	T	Data bus
		7	T	keep	T	keep	keep

Port Name Pin Name	MCU			Hardware Standby Mode	Software	Bus Right Release State	Program Execution State or Sleep Mode
	Operating Mode	Power-on Reset	Manual Reset		Standby Mode or Watch Mode		
PF7/ $\phi$	4 to 6	Clock output	[DDR=0]	T	[DDR=0]	[DDR=0]	[DDR=0]
			Input port	[DDR=1]		Input port	Input port
			[DDR=1]		[DDR=1]	[DDR=1]	[DDR=1]
			Clock output		H	Clock output	Clock output
	7	T	keep	T	[DDR=0]	[DDR=0]	[DDR=0]
					Input port	Input port	Input port
					[DDR=1]	[DDR=1]	[DDR=1]
					H	Clock output	Clock output
PF6/ $\overline{AS}^{*2}$	4 to 6	H	H	T	[OPE=0]	T	$\overline{AS}$ , $\overline{RD}$ , $\overline{HWR}$
PF5/ $\overline{RD}^{*2}$					T		
PF4/ $\overline{HWR}^{*2}$					[OPE=1]		
					H		
	7	T	keep	T	keep	keep	I/O port
PF3/ $\overline{LWR}$	7	T	keep	T	keep	keep	I/O port
8-bit bus	4 to 6	(Mode 4)	keep	T	keep	keep	I/O port
		H					
16-bit bus	4 to 6	(Modes 5 ,6)	H	T	[OPE=0]	T	$\overline{LWR}$
		T			T		
					[OPE=1]		
					H		
PF2/ $\overline{WAIT}^{*2}$	4 to 6	T	keep	T	[WAITE=0]	[WAITE=0]	[WAITE=0]
					keep	keep	I/O port
					[WAITE=1]	[WAITE=1]	[WAITE=1]
					T	T	$\overline{WAIT}$
	7	T	keep	T	keep	keep	I/O port
PF1/ $\overline{BACK}^{*2}$	4 to 6	T	keep	T	[BRLE=0]	L	[BRLE=0]
					keep		I/O port
					[BRLE=1]		[BRLE=1]
					H		$\overline{BACK}$
	7	T	keep	T	keep	keep	I/O port

Port Name Pin Name	MCU			Hardware Standby Mode	Software	Bus Right Release State	Program Execution State or Sleep Mode
	Operating Mode	Power-on Reset	Manual Reset		Standby Mode or Watch Mode		
PF0/ $\overline{\text{BREQ}}$	4 to 6	T	keep	T	[BRLE=0]	T	[BRLE=0]
					keep		I/O port
					[BRLE=1]		[BRLE=1]
					T		$\overline{\text{BREQ}}$
PG4/ $\overline{\text{CS0}}^{*2}$	4 and 5	H	keep	T	[DDR•OPE=0]	T	[DDR=0]
					T		I/O port
					[DDR•OPE=1]		[DDR=1]
					H		$\overline{\text{CS0}}$
	6	T					(When sleep mode)H
	7	T	keep	T	keep	keep	I/O port
PG3/ $\overline{\text{CS1}}^{*2}$	4 to 6	T	keep	T	[DDR•OPE=0]	T	[DDR=0]
PG2/ $\overline{\text{CS2}}^{*2}$					T		I/O port
PG1/ $\overline{\text{CS3}}$					[DDR•OPE=1]		[DDR=1]
					H		$\overline{\text{CS1}}$ to $\overline{\text{CS3}}$
	7	T	keep	T	keep	keep	I/O port
PG0 <sup>*3</sup>	4 to 7	T	keep	T	keep	keep	I/O port

## Legend:

H: High level

L: Low level

T: High impedance

keep: Input port level is high impedance, and output port level is retained.

DDR: Data direction register

OPE: Output port enable

WAITE: Wait port enable

BRLE: Bus release enable

- Notes:
1. L (address input) in mode 4 or 5
  2. Supported only by the H8S/2218 Group.
  3. Supported only by the H8S/2212 Group.



## B. Product Model Lineup

Product Class		Part No.	Model Name	Marking	Package (code)
H8S/2218 Group	Flash memory Version	HD64F2218	HD64F2218TF24	F2218TF24	100-pin TQFP (TFP-100G, TFP-100GV)
			HD64F2218BR24	64F2218BR24	112-pin P-LFBGA (BP-112, BP-112V)
		HD64F2218U	HD64F2218UTF24	F2218UTF24	100-pin TQFP (TFP-100G, TFP-100GV)
			HD64F2218UBR24	64F2218UBR24	112-pin P-LFBGA (BP-112, BP-112V)
		HD64F2218CU	HD64F2218CUTF24	F2218CUTF24	100-pin TQFP (TFP-100GV)
			HD64F2218CUBR24	64F2218CUBR24	112-pin P-LFBGA (BP-112V)
	Masked ROM Version	HD6432217	HD6432217(***)TF	2217(***)TF	100-pin TQFP (TFP-100G, TFP-100GV)
			HD6432217(***)BR	2217(***)BR	112-pin P-LFBGA (BP-112, BP-112V)
		HD64F2212	HD64F2212FP24	2212FP24	64-pin LQFP (FP-64E, FP-64EV)
			HD64F2212NP24	F2212NP24	64-pin VQFN (TNP-64B, TNP-64BV)
		HD64F2212U	HD64F2212UFP24	2212UFP24	64-pin LQFP (FP-64E, FP-64EV)
			HD64F2212UNP24	F2212UNP24	64-pin VQFN (TNP-64B, TNP-64BV)
H8S/2212 Group	Flash memory Version	HD64F2212CU	HD64F2212CUFP24	2212CUFP24	64-pin LQFP (FP-64EV)
			HD64F2212CUNP24	F2212CUNP24	64-pin VQFN (TNP-64BV)
	HD64F2211	HD64F2211FP24	2211FP24	64-pin LQFP (FP-64E, FP-64EV)	
		HD64F2211NP24	F2211NP24	64-pin VQFN (TNP-64B, TNP-64BV)	

# Appendix

Product Class		Part No.	Model Name	Marking	Package (code)
H8S/2212 Group	Flash memory Version	HD64F2211U	HD64F2211UFP24	2211UFP24	64-pin LQFP (FP-64E, FP-64EV)
			HD64F2211UNP24	F2211UNP24	64-pin VQFN (TNP-64B, TNP-64BV)
		HD64F2211CU	HD64F2211CUFP24	2211CUFP24	64-pin LQFP (FP-64EV)
			HD64F2211CUNP24	F2211CUNP24	64-pin VQFN (TNP-64BV)
	HD64F2210CU	HD64F2210CUFP24	2210CUFP24	64-pin LQFP (FP-64EV)	
		HD64F2210CUNP24	F2210CUNP24	64-pin VQFN (TNP-64BV)	
	Masked ROM Version	HD6432211	HD6432211(***)FP	2211(***)FP	64-pin LQFP (FP-64E, FP-64EV)
			HD6432211(***)NP	2211(***)NP	64-pin VQFN (TNP-64B, TNP-64BV)
		HD6432210	HD6432210(***)FP	2210(***)FP	64-pin LQFP (FP-64E, FP-64EV)
			HD6432210(***)NP	2210(***)NP	64-pin VQFN (TNP-64B, TNP-64BV)
HD6432210S		HD6432210S(***)FP	2210S(***)FP	64-pin LQFP (FP-64E, FP-64EV)	
		HD6432210S(***)NP	2210S(***)NP	64-pin VQFN (TNP-64B, TNP-64BV)	

Legend:

\*\*\*: ROM code

## C. Package Dimensions

The package dimension that is shown in the Renesas Semiconductor Package Data Book has priority.

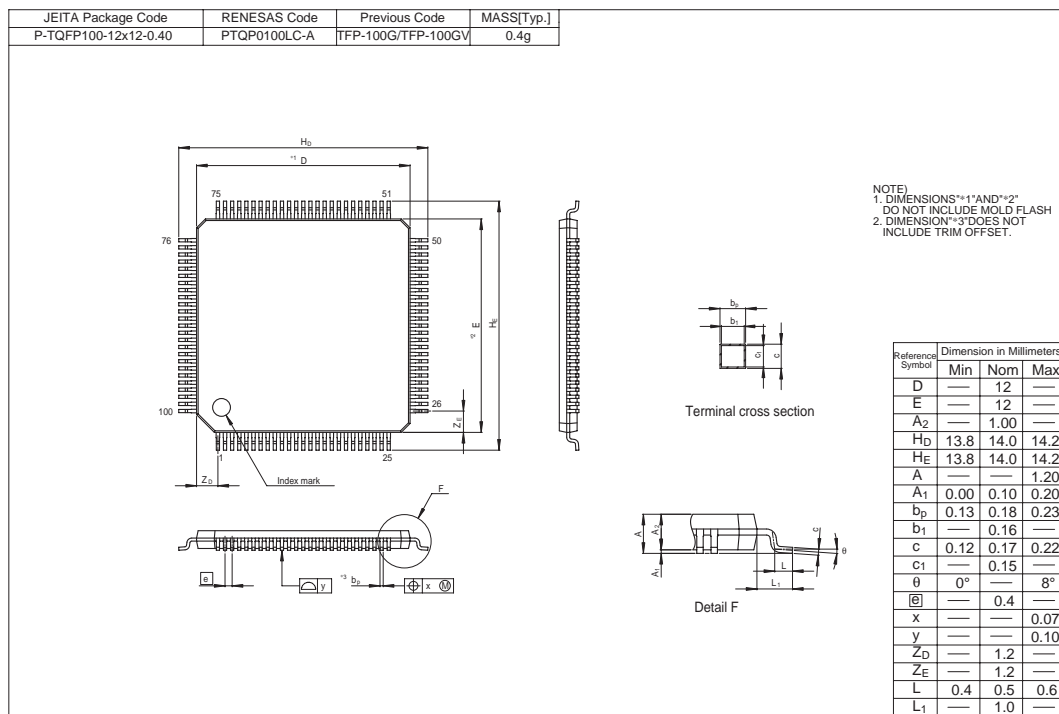


Figure C.1 TFP-100G and TFP-100GV Package Dimensions

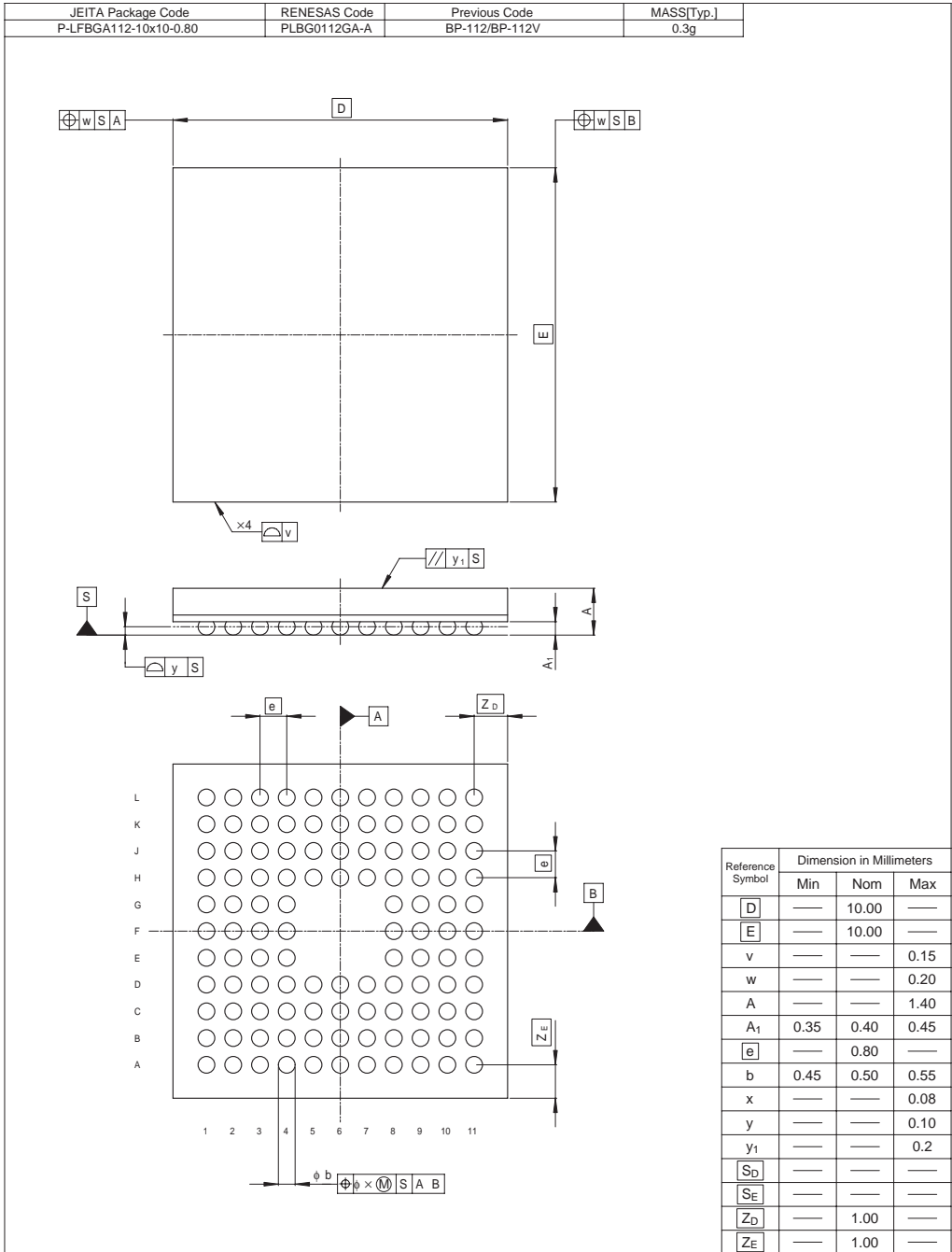


Figure C.2 BP-112 and BP-112V Package Dimensions

JEITA Package Code	RENESAS Code	Previous Code	MASS[Typ.]
P-LQFP64-10x10-0.50	PLQP0064KC-A	FP-64E/FP-64EV	0.4g

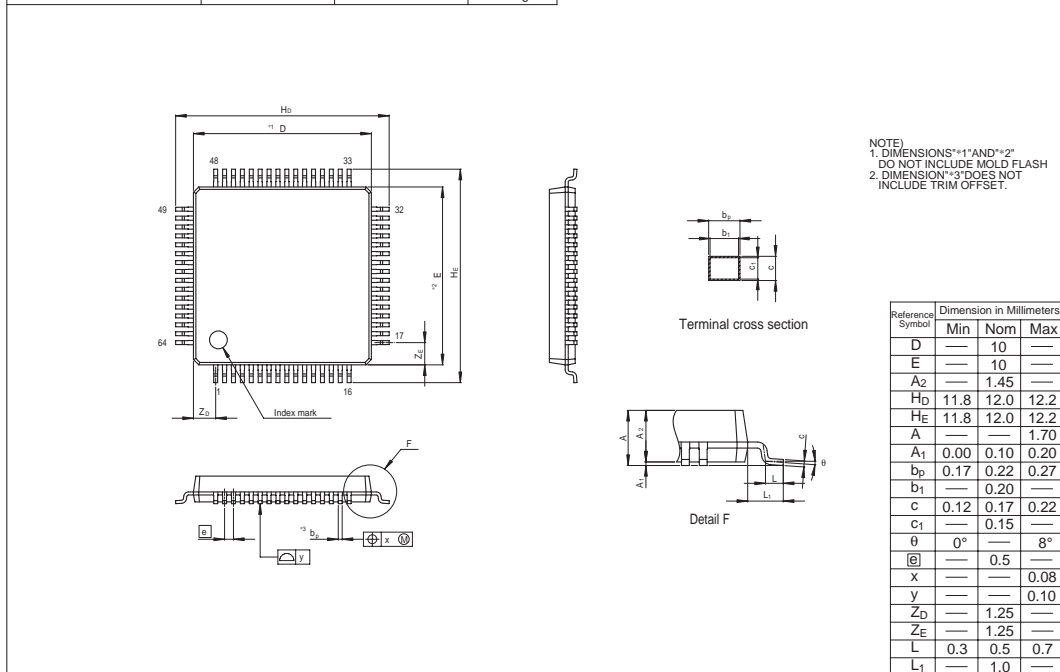
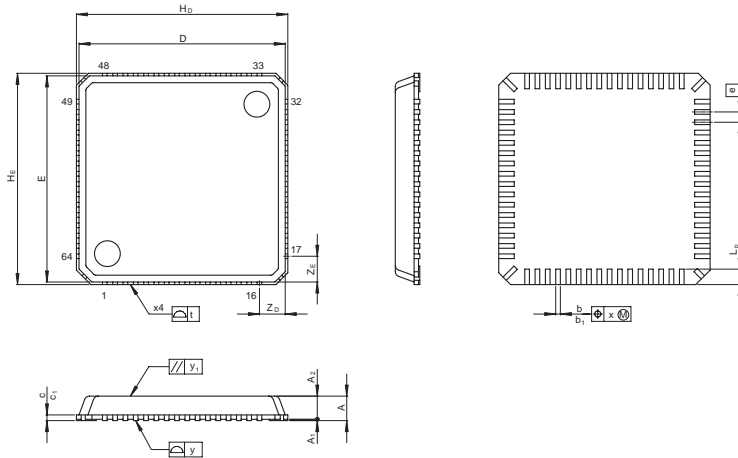


Figure C.3 FP-64E and FP-64EV Package Dimensions

JEITA Package Code	RENESAS Code	Previous Code	MASS[Typ.]
P-VQFN64-8x8-0.40	PVQN0064LB-A	TNP-64B/TNP-64BV	0.12g



Reference Symbol	Dimension in Millimeters		
	Min	Nom	Max
D	—	8.0	—
E	—	8.0	—
A <sub>2</sub>	—	0.89	—
A	—	—	0.95
A <sub>1</sub>	0.005	0.02	0.04
b	0.13	0.18	0.23
b <sub>1</sub>	—	0.16	—
Ⓢ	—	0.4	—
L <sub>p</sub>	0.50	0.60	0.70
x	—	—	0.05
y	—	—	0.05
y <sub>1</sub>	—	—	0.2
t	—	—	0.2
H <sub>D</sub>	—	8.2	—
H <sub>E</sub>	—	8.2	—
Z <sub>D</sub>	—	1.0	—
Z <sub>E</sub>	—	1.0	—
c	0.17	0.22	0.25
c <sub>1</sub>	—	0.20	—

**Figure C.4 TNP-64B and TNP-64BV Package Dimensions**

# Index

16-Bit Timer Pulse Unit.....	273	Effective Address Extension.....	57
A/D Conversion Time.....	544	Emulation.....	577
A/D Converter .....	535	Erase/Erase-Verify.....	581
A/D Converter Activation.....	323	Erasing units .....	558, 559
Absolute Address.....	59	Error Protection.....	583
Address Space.....	38	Exception Handling .....	81
Addressing Mode.....	58	Extended Control Register (EXR) .....	41
ADI .....	546	External Trigger .....	545
Advanced Mode.....	36	Flash Memory .....	553
Arithmetic Operations Instructions.....	49	Framing error.....	410
Asynchronous Mode .....	403	Free-running count operation.....	302
Bcc.....	46, 54	General Registers.....	40
Bit Manipulation Instructions .....	52	Hardware Protection .....	583
Bit rate .....	395	Immediate .....	60
Block Data Transfer Instruction.....	56	Input Capture Function .....	305
Boot Mode .....	567	Instruction Set.....	45
Boundary Scan.....	449	Internal bus masters .....	115
Branch Instructions.....	54	Interrupt Control Mode.....	103
Break.....	441	Interrupt Controller .....	91
Buffer Operation.....	309	Interrupt Exception Handling Vector Table .....	101
Bulk-In Transfer .....	513	Interrupt Mask Bit.....	42
Bulk-Out Transfer.....	515	Interrupt mask level .....	41
Bus Arbitration .....	155	Interrupt priority register.....	91
Bus cycle.....	133	Interrupt-In Transfer .....	512
Clock Pulse Generator .....	595	Interrupts.....	87
Condition Field.....	57	Interval Timer Mode.....	344
Condition-Code Register .....	42	Logic Operations Instructions.....	50
Control Transfer.....	506	Mark State.....	442
CPU Operating Modes.....	34	Masked ROM.....	593
Data reading procedure.....	359	Memory cycle .....	131
Data Transfer Instructions .....	48	Memory Indirect .....	61
DMA Transfer Specifications .....	520		
Effective Address.....	58, 62		

Memory Map.....	77	ETCR .....	162, 635, 643, 652
NMI Interrupt.....	99	FLMCR1 .....	562, 638, 647, 654
Normal Mode .....	34	FLMCR2 .....	563, 638, 647, 654
On-Board Programming.....	567	IDCODE.....	454
Operating Mode Selection.....	71	IER .....	95, 634, 641, 650
Operation Field.....	57	INSTR .....	452
Overflow .....	345	IOAR.....	161, 635, 643, 652
Overrun error.....	410	IPR .....	94, 635, 642, 651
Parity error .....	410	ISCR.....	96, 634, 641, 650
Periodic count operation.....	302	ISR .....	98, 634, 641, 650
Phase Counting Mode .....	317	LPWRCR .....	597, 634, 641, 650
PLL Circuit .....	604	MAR.....	161, 635, 643, 652
Processing of USB Standard Commands and Class/Vendor Commands .....	516	MDCR .....	72, 634, 641, 650
Program Counter .....	41	MSTPCR.....	614, 634, 641, 650
Program/Program-Verify .....	579	P1DDR .....	216, 634, 642, 650
Program-Counter Relative.....	60	P1DR.....	217, 636, 644, 652
Programmer Mode .....	585	P3DDR .....	223, 634, 642, 650
Programming units .....	558, 559	P3DR.....	224, 636, 644, 652
Programming/Erasing in User Program Mode .....	576	P3ODR .....	225, 634, 642, 651
PWM Modes .....	313	P7DDR .....	228, 634, 642, 650
Realtime Clock (RTC) .....	349	P7DR.....	229, 636, 644, 652
Register		PADDR .....	233, 634, 642, 650
ABWCR.....	118, 635, 643, 651	PADR .....	234, 636, 644, 652
ADCR.....	540, 638, 647, 654	PAODR.....	235, 634, 642, 651
ADCSR .....	538, 638, 647, 654	PAPCR.....	235, 634, 642, 651
ADDR .....	538, 638, 647, 654	PBDDR .....	239, 634, 642, 650
ASTCR.....	119, 635, 643, 651	PBDR .....	240, 636, 644, 652
BCRH.....	124, 635, 643, 651	PBPCR .....	241, 634, 642, 651
BCRL .....	125, 635, 643, 651	PCDDR .....	245, 634, 642, 650
BRR.....	395, 638, 646, 654	PCDR .....	246, 636, 644, 652
BSCANR.....	454	PCPCR .....	247, 634, 642, 651
BYPASS.....	454	PDDDR .....	250, 634, 642, 651
DMACR.....	163, 637, 646, 653	PDDR .....	251, 636, 644, 652
EBR1.....	564, 638, 647, 654	PDPCR .....	252, 634, 642, 651
EBR2.....	564, 638, 647, 654	PEDDR.....	255, 634, 642, 651
		PEDR .....	256, 636, 644, 652
		PEPCR .....	257, 634, 642, 651
		PFCR.....	126, 634, 641, 650
		PFDDR.....	262, 634, 642, 651
		PFDR.....	263, 636, 644, 652
		PGDDR.....	268, 634, 642, 651



PGDR.....	269, 636, 644, 652	TMDR.....	282, 636, 644, 652
PORT1.....	217, 639, 648, 655	TSR.....	294, 636, 644, 652
PORT3.....	224, 639, 648, 655	TSTR.....	297, 635, 642, 651
PORT4.....	227, 639, 648, 655	TSYR.....	298, 635, 642, 651
PORT7.....	230, 639, 648, 655	UCTLR.....	468, 632, 640, 649
PORT9.....	232, 639, 648, 655	UCVR.....	488, 633, 641, 649
PORTA.....	234, 639, 648, 655	UDMAR.....	471, 632, 640, 649
PORTB.....	240, 639, 648, 655	UDRR.....	472, 632, 640, 649
PORTC.....	246, 639, 648, 655	UDSR.....	487, 633, 641, 649
PORTD.....	251, 639, 648, 655	UEDR0i.....	477, 632, 640, 649
PORTE.....	256, 639, 648, 655	UEDR0o.....	478, 632, 640, 649
PORTF.....	263, 639, 648, 655	UEDR0s.....	477, 632, 640, 649
PORTG.....	269, 639, 648, 655	UESTL0.....	476, 632, 640, 649
RAMER.....	565, 635, 643, 651	UESTL1.....	477, 632, 640, 649
RDR.....	368, 638, 646, 654	UESZ0o.....	479, 633, 640, 649
RHRDR.....	352	UESZ2.....	479, 633, 640, 649
RMINDR.....	351, 637, 646, 653	UFCLR0.....	475, 632, 640, 649
RSECDR.....	637, 646, 653	UIER0.....	484, 633, 640, 649
RSTCSR.....	342, 637, 646, 653	UIER1.....	485, 633, 640, 649
RTCCR1.....	354, 637, 646, 653	UIER3.....	485, 633, 640, 649
RTCCR2.....	355, 637, 646, 653	UIFR0.....	480, 633, 640, 649
RTCCSR.....	356, 637, 646, 653	UIFR1.....	482, 633, 640, 649
RWKDR.....	353, 637, 646, 653	UIFR3.....	483, 633, 640, 649
SBYCR.....	611, 634, 641, 650	UISR0.....	486, 633, 640, 649
SCKCR.....	596, 634, 641, 650	UISR1.....	486, 633, 641, 649
SCMR.....	383, 638, 646, 654	UISR3.....	487, 633, 641, 649
SCR.....	373, 638, 646, 654	UTRG0.....	473, 632, 640, 649
SCRX.....	566, 633, 641, 650	UTSTR0.....	489, 633, 641, 650
SEMRA_0.....	384, 634, 641, 650	UTSTR1.....	490, 633, 641, 650
SEMRB_0.....	386, 634, 641, 650	WCRH.....	120, 635, 643, 651
SMR.....	369, 638, 646, 654	WCRL.....	120, 635, 643, 651
SSR.....	377, 638, 646, 654	Register Direct.....	58
SYSCR.....	72, 634, 641, 650	Register Field.....	57
TCNT.....	297, 340, 636, 637, 644, 646, 652, 653	Register Indirect.....	58
TCR.....	279, 636, 644, 652	Register Indirect with Displacement.....	59
TCSR.....	340, 637, 646, 653	Register Indirect with Post-Increment.....	59
TDR.....	368, 638, 646, 654	Register indirect with pre-decrement.....	59
TGR.....	297, 636, 644, 652	Reset.....	83
TIER.....	293, 636, 644, 652	Reset exception handling.....	84
TIOR.....	284, 636, 644, 652	Scan Mode.....	543

---

Serial Communication Interface.....	363	TGI0C .....	322
Shift Instructions .....	51	TGI0D .....	322
Single Mode .....	542	TGI1A .....	322
Software Protection.....	583	TGI1B .....	322
Stack pointer (SP) .....	40	TGI2A .....	322
Stack Status.....	89	TGI2B .....	322
Stall Operations.....	517	Toggle output .....	304
Suspend and Resume.....	502	Trace Bit.....	41
Synchronous Operation.....	307	Traces .....	87
System Control Instruction.....	55	Trap Instruction.....	88
TCI0V .....	322	TRAPA.....	60, 88
TCI1U .....	322	Universal Serial Bus.....	465
TCI1V .....	322	USB Cable Connection/Disconnection ..	498
TCI2U .....	322	Watchdog timer.....	339
TCI2V .....	322	Waveform Output by Compare Match...	303
TGI0A .....	322	WOVI.....	345
TGI0B .....	322		

---

**Renesas 16-Bit Single-Chip Microcomputer  
Hardware Manual  
H8S/2218 Group, H8S/2212 Group**

Publication Date: 1st Edition, February 2003  
Rev.7.00, December 24, 2008

Published by: Sales Strategic Planning Div.  
Renesas Technology Corp.

Edited by: Customer Support Department  
Global Strategic Communication Div.  
Renesas Solutions Corp.

Renesas Technology Corp. Sales Strategic Planning Div. Nippon Bldg., 2-6-2, Ohte-machi, Chiyoda-ku, Tokyo 100-0004, Japan

---



## RENESAS SALES OFFICES

<http://www.renesas.com>

Refer to "<http://www.renesas.com/en/network>" for the latest and detailed information.

### **Renesas Technology America, Inc.**

450 Holger Way, San Jose, CA 95134-1368, U.S.A  
Tel: <1> (408) 382-7500, Fax: <1> (408) 382-7501

### **Renesas Technology Europe Limited**

Dukes Meadow, Millboard Road, Bourne End, Buckinghamshire, SL8 5FH, U.K.  
Tel: <44> (1628) 585-100, Fax: <44> (1628) 585-900

### **Renesas Technology (Shanghai) Co., Ltd.**

Unit 204, 205, AZIA Center, No.1233 Lujiazui Ring Rd, Pudong District, Shanghai, China 200120  
Tel: <86> (21) 5877-1818, Fax: <86> (21) 6887-7858/7898

### **Renesas Technology Hong Kong Ltd.**

7th Floor, North Tower, World Finance Centre, Harbour City, Canton Road, Tsimshatsui, Kowloon, Hong Kong  
Tel: <852> 2265-6688, Fax: <852> 2377-3473

### **Renesas Technology Taiwan Co., Ltd.**

10th Floor, No.99, Fushing North Road, Taipei, Taiwan  
Tel: <886> (2) 2715-2888, Fax: <886> (2) 3518-3399

### **Renesas Technology Singapore Pte. Ltd.**

1 Harbour Front Avenue, #06-10, Keppel Bay Tower, Singapore 098632  
Tel: <65> 6213-0200, Fax: <65> 6278-8001

### **Renesas Technology Korea Co., Ltd.**

Kukje Center Bldg. 18th Fl., 191, 2-ka, Hangang-ro, Yongsan-ku, Seoul 140-702, Korea  
Tel: <82> (2) 796-3115, Fax: <82> (2) 796-2145

### **Renesas Technology Malaysia Sdn. Bhd**

Unit 906, Block B, Menara Amcorp, Amcorp Trade Centre, No.18, Jln Persiaran Barat, 46050 Petaling Jaya, Selangor Darul Ehsan, Malaysia  
Tel: <603> 7955-9390, Fax: <603> 7955-9510





# H8S/2218 Group, H8S/2212 Group Hardware Manual



Renesas Electronics Corporation

1753, Shimonumabe, Nakahara-ku, Kawasaki-shi, Kanagawa 211-8668 Japan

REJ09B0074-0700