



The Future of Analog IC Technology®

MP2013

40V, 150mA, Low Quiescent Current Linear Regulator

DESCRIPTION

The MP2013 is a low power linear regulator that supplies power to systems with high voltage batteries. It includes a wide 2.5V to 40V input range, low dropout voltage and low quiescent supply current. The low quiescent current and low dropout voltage allow operations at extremely low power levels. Therefore, the MP2013 are ideal for the low power microcontrollers and the battery-powered equipments.

The MP2013 provides wide variety of fixed output voltage options (if request): 1.8V, 1.9V, 2.3V, 2.5V, 3.0V, 3.3V, 3.45V, 5.0V; and also provides the output adjustable option (from 1.215V to 15V).

The regulator output current is internally limited and the device is protected against over-load and over-temperature conditions.

The MP2013 also includes thermal shutdown and current limiting fault protection, and is available in a QFN6 (2mmx2mm) and QFN8 (3mmx3mm) packages.

FEATURES

- 2.5V to 40V Input Range
- 3.2 μ A Quiescent Supply Current
- Stable With LOW-VALUE Output Ceramic Capacitor (>0.47 μ F)
- 150mA Specified Current
- 620mV Dropout at 150mA Load
- Available in Fixed and Adjustable Output (1.215V to 15V) Versions
- Output \pm 2% Accuracy
- Specified Current Limit
- Thermal Shutdown
- -40°C to +125°C Specified Junction Temperature Range
- Available in a QFN6 (2mmx2mm) and QFN8 (3mmx3mm) Package

APPLICATIONS

- Industrial and Automotive Applications
- Portable and Battery-Powered Equipment
- Ultra-Low-Power Microcontrollers
- Cellular Handsets
- Medical Imaging

All MPS parts are lead-free, halogen-free, and adhere to the RoHS directive. For MPS green status, please visit the MPS website under Quality Assurance. "MPS", the MPS logo, and "Simple, Easy Solutions" are trademarks of Monolithic Power Systems, Inc. or its subsidiaries.

TYPICAL APPLICATION

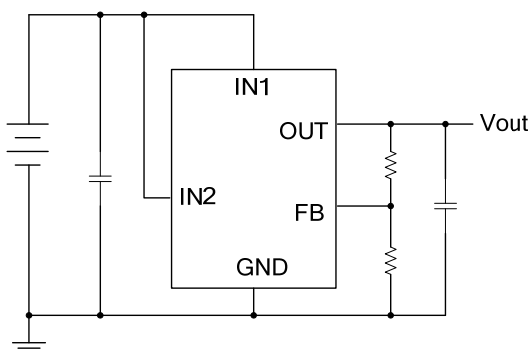

Output Adjustable Version

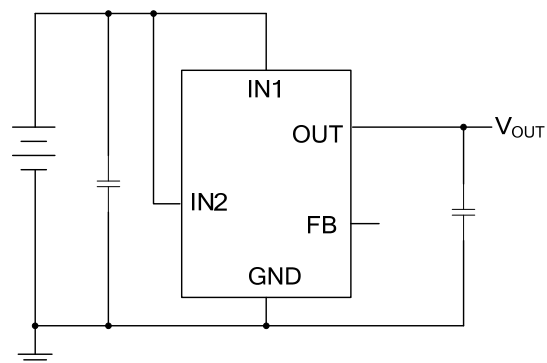

Output Fixed Version

ORDERING INFORMATION

Part Number*	Package	Top Marking
MP2013GG	QFN6 (2mmx2mm)	AX
MP2013GQ	QFN8 (3mmx3mm)	AFF
MP2013GQ-33	QFN8 (3mmx3mm)	AGG

* For Tape & Reel, add suffix -Z (e.g. MP2013GG-Z);

PACKAGE REFERENCE

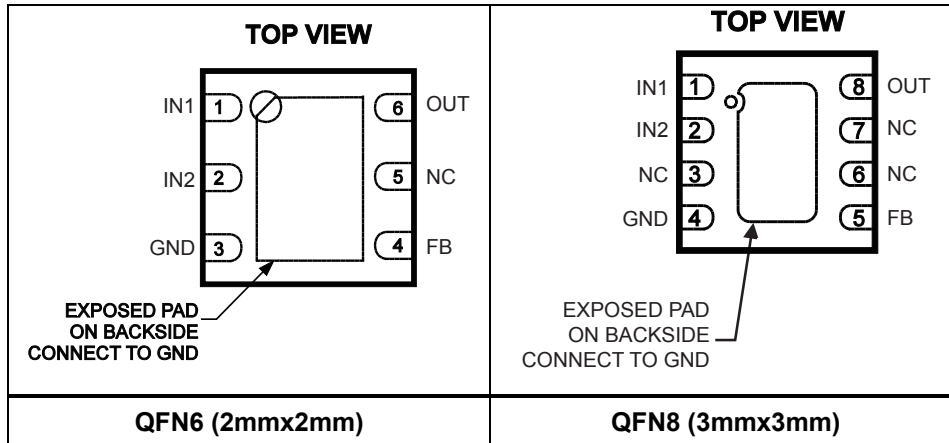

ABSOLUTE MAXIMUM RATINGS ⁽¹⁾

IN1, IN2	-0.3V to +42V
OUT	-0.3V to +17V
FB	-0.3V to +6V
Lead Temperature	260°C
Storage Temperature	-65°C to +150°C
Continuous Power Dissipation (T _A = 25°C) ⁽²⁾	
QFN8(3x3mm)	2.08W
QFN6(2x2mm)	1.25W

ESD Ratings ⁽³⁾

HBM (Human Body Mode)	2kV
MM (Machine Mode)	200V

Recommended Operating Conditions ⁽⁴⁾

Supply Voltage V _{IN}	2.5V to 40V
Output Voltage V _{OUT}	1.215V to 15V
Operating Junction Temp. (T _J)	-40°C to +125°C

Thermal Resistance ⁽⁵⁾	θ_{JA}	θ_{JC}
QFN6(2x2mm)	80	16 ... °C/W
QFN8(3x3mm)	48	11 ... °C/W

Notes:

- Exceeding these ratings may damage the device.
- The maximum allowable power dissipation is a function of the maximum junction temperature T_J (MAX), the junction-to-ambient thermal resistance θ_{JA} , and the ambient temperature T_A. The maximum allowable continuous power dissipation at any ambient temperature is calculated by P_D (MAX) = (T_J (MAX) - T_A) / θ_{JA} . Exceeding the maximum allowable power dissipation will cause excessive die temperature, and the regulator will go into thermal shutdown. Internal thermal shutdown circuitry protects the device from permanent damage.
- Devices are ESD sensitive. Handling precaution recommended.
- The device is not guaranteed to function outside of its operating conditions.
- Measured on JESD51-7, 4-layer PCB.

ELECTRICAL CHARACTERISTICS
 $V_{OUT(NOM)} = 5V (V_{IN} \geq 6V)$ or $FB (V_{IN} < 6V)$, $I_{OUT} = 1mA$, $C_{OUT} = 1\mu F$, $T_J = 25^\circ C$, unless otherwise noted.

Parameter	Symbol	Condition	Min	Typ	Max	Units	
Input Voltage	V_{IN}		2.5		40	V	
Output Voltage range	V_{OUT}		1.215		15	V	
GND Pin Current	I_{GND}	MP2013	$0 < I_{OUT} < 1mA$, $V_{IN} = 2.5V$ to $40V$		3.2	7.2	μA
			$1mA < I_{OUT} < 30mA$, $V_{IN} = 2.5V$ to $15V$		14	18	
			$30mA < I_{OUT} < 150mA$, $V_{IN} = 3V$ to $6V$		35	50	
		MP2013-33	$0 < I_{OUT} < 1mA$, $V_{IN} = 4.3V$ to $40V$		4.4	8	
			$1mA < I_{OUT} < 30mA$, $V_{IN} = 4.3V$ to $15V$		15	19	
			$30mA < I_{OUT} < 150mA$, $V_{IN} = 4.3V$		35	50	
Load Current Limit	I_{LIMIT}	$V_{OUT} = 0V$, $V_{IN} = 6V$ to $15V$	180	270	400	mA	
Output Voltage Accuracy		MP2013-33, $V_{IN} = 4.3V$, $I_O = 0$	3.234	3.3	3.366	V	
FB Voltage	V_{FB}	$FB = OUT$, $V_{IN} = 5V$	1.191	1.215	1.239	V	
Dropout Voltage $V_{IN} = V_{OUT(NOM)} - 0.1V$	$V_{DROPOUT}$	MP2013, $I_{LOAD} = 150mA$, $V_{OUT(NOM)} = 5V$		620	900	mV	
		MP2013-33, $I_{LOAD} = 150mA$		740	900		
FB Pin Input Current	I_{FB}	MP2013, $V_{FB} = 1.3V$, $V_{IN} = 6V$, OUT floating	-50	+4	+50	nA	
		MP2013-33, $V_{FB} = 1.3V$, $V_{IN} = 6V$, OUT floating	0.98	1.25	1.52	μA	
Line Regulation ⁽⁶⁾		$V_{IN} = 2.5$ to $40V$, $I_{LOAD} = 1mA$, $OUT = FB$		0.01	0.05	%/V	
Load Regulation ⁽⁷⁾		MP2013, $I_{LOAD} = 100\mu A$ to $150mA$, $OUT = FB$, $V_{IN} = 3V$ to $6V$		0.003	0.005	%mA	
		MP2013-33, $I_{LOAD} = 100\mu A$ to $150mA$, $V_{IN} = 4.3V$ to $6V$		0.005	0.01		
Output Voltage PSRR ⁽⁸⁾		100Hz, $C_{IN} = 100pF$, $C_{OUT} = 4.7\mu F$ $I_{LOAD} = 10mA$, $V_{IN} = 6V$		58		dB	
		1kHz, $C_{IN} = 100pF$, $C_{OUT} = 4.7\mu F$ $I_{LOAD} = 10mA$, $V_{IN} = 6V$		41		dB	
		100kHz, $C_{IN} = 100pF$, $C_{OUT} = 4.7\mu F$ $I_{LOAD} = 10mA$, $V_{IN} = 6V$		55		dB	

ELECTRICAL CHARACTERISTICS (continued)
 $V_{OUT(NOM)} = 5V$ ($V_{IN} \geq 6V$) or FB ($V_{IN} < 6V$), $I_{OUT} = 1mA$, $C_{OUT} = 1\mu F$, $T_J = 25^\circ C$, unless otherwise noted.

Parameter	Symbol	Condition	Min	Typ	Max	Units
Startup Response Time		$R_{LOAD} = 500\Omega$, $C_{OUT} = 6.8\mu F$, $V_{OUT} = 5V$			2.5	ms
Thermal Shutdown ⁽⁸⁾	T_{SD}		150	165		$^\circ C$
Thermal Shutdown Hysteresis ⁽⁸⁾	ΔT_{SD}			20		$^\circ C$

Notes:

$$6) \text{ Line Regulation} = \frac{|V_{OUT[V_{IN(MAX)}]} - V_{OUT[V_{IN(MIN)}]}|}{(V_{IN(MAX)} - V_{IN(MIN)}) \times V_{OUT(NOM)}} \times (\% / V)$$

$$7) \text{ Load Regulation} = \frac{|V_{OUT[I_{OUT(MAX)}]} - V_{OUT[I_{OUT(MIN)}]}|}{(I_{OUT(MAX)} - I_{OUT(MIN)}) \times V_{OUT(NOM)}} \times (\% / mA)$$

8) Derived from bench characterization. Not tested in production.

PIN FUNCTIONS

Pin #		Name	Description
QFN6 (2mmx 2mm)	QFN8 (3mmx 3mm)		
1	1	IN1	Input Voltage. Connect a 2.5V to 40V supply to this pin.
2	2	IN2	VIN pin to power internal logic. Connect to IN1.
3, exposed pad	4, exposed pad	GND	Ground (the exposed pad and GND pin must be connected to the same ground plane)
4	5	FB	Feedback input pin, regulated to 1.215V nominally. Connected to an external resistive divider between OUT and GND to set output voltage. For fixed output version, this pin can be just float.
6	8	OUT	Regulated output voltage, only low-value ceramic capacitor ($\geq 0.47\mu\text{F}$) on output is required for stability.
5	3, 6, 7	NC	No connection. May be left open or tied to Ground for improved thermal performance.

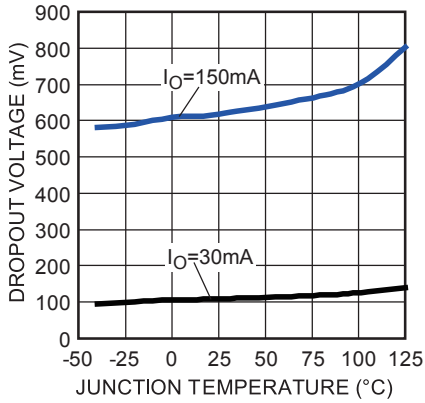
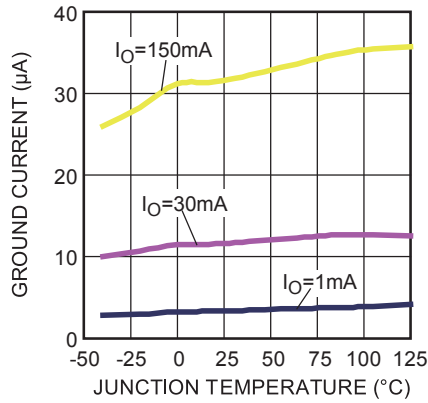
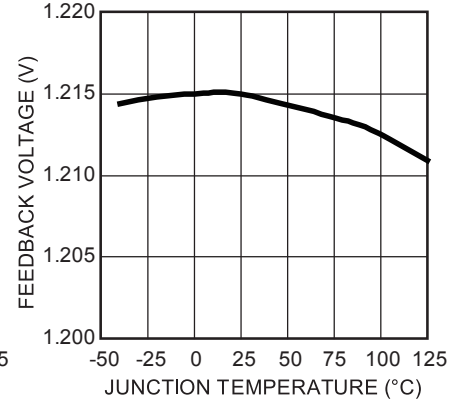
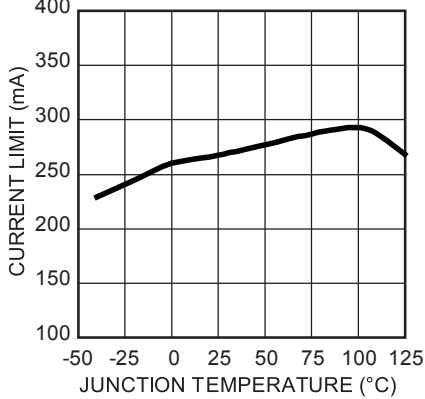
TYPICAL CHARACTERISTICS
Dropout Voltage vs. Junction Temperature
 $V_{OUT}=5V$

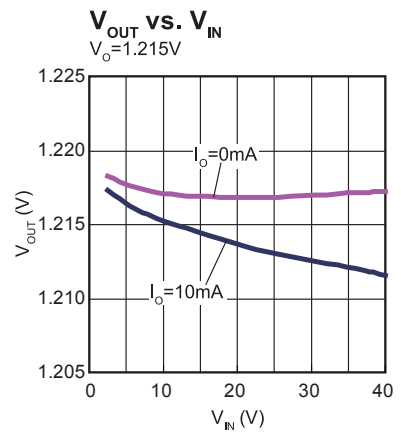
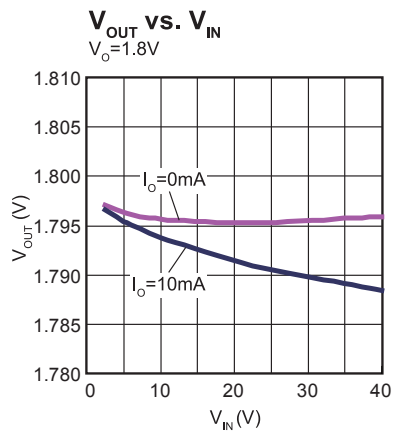
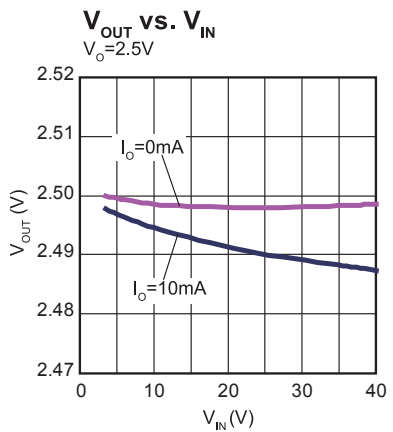
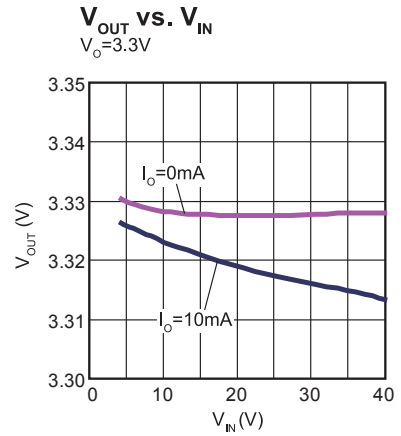
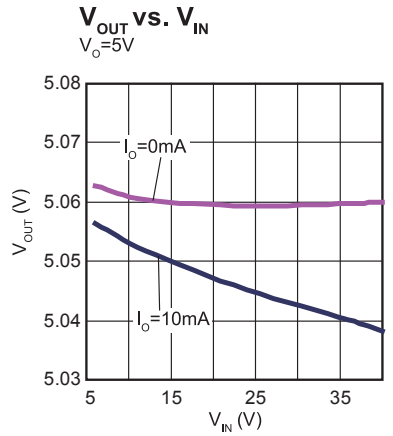
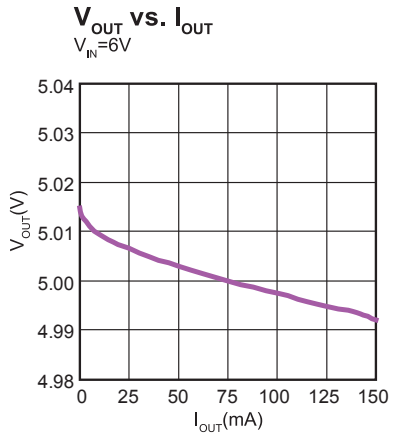
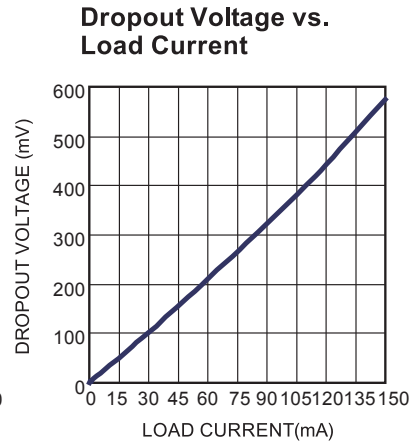
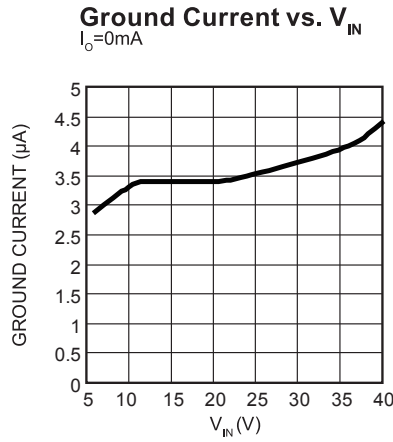
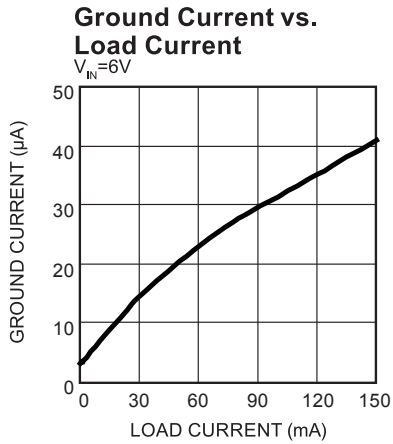
Ground Current vs. Junction Temperature
 $V_{IN}=6V, V_{OUT}=5V$

Feedback Voltage vs. Junction Temperature
 $V_{IN}=6V$

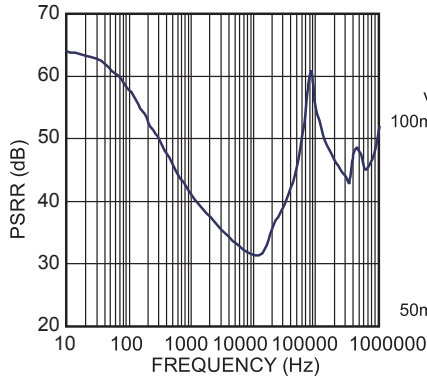
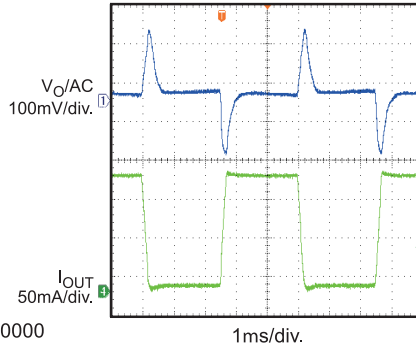
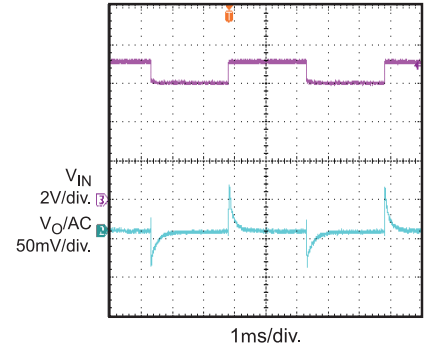
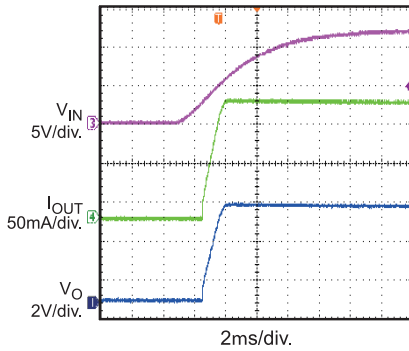
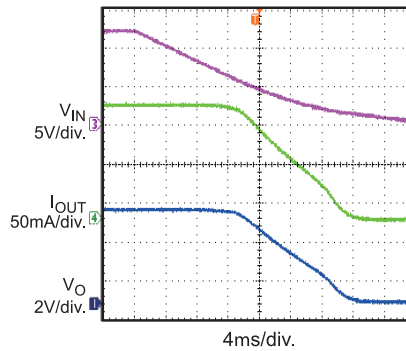
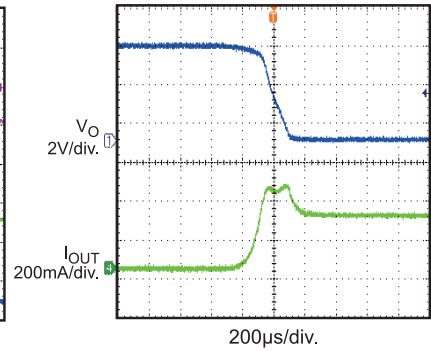
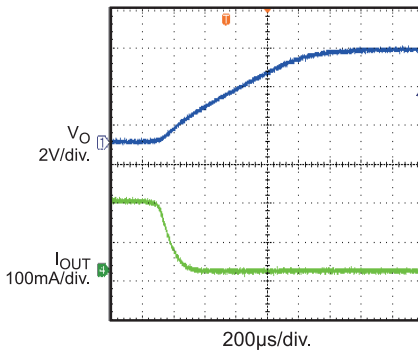
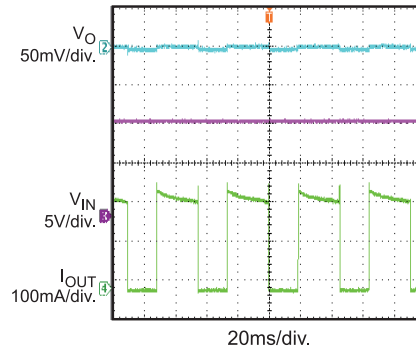
Current Limit vs. Junction Temperature
 $V_{IN}=6V$

TYPICAL PERFORMANCE CHARACTERISTICS
 $C_{IN} = 1\mu F$, $C_{OUT} = 4.7\mu F$, $V_{OUT}=5V$, $T_A = 25^\circ C$, unless otherwise noted.

TYPICAL PERFORMANCE CHARACTERISTICS (continued)
 $C_{IN} = 1\mu F, C_{OUT} = 4.7\mu F, V_{OUT} = 5V, T_A = 25^\circ C$, unless otherwise noted.

PSRR vs. Frequency
 $V_{IN1} = V_{IN2} = 6V, I_O = 10mA, C_{IN} = 100pF$

Load Transient
 $V_{IN} = 12V, I_{OUT} = 8mA-150mA$

Line Transient
 $V_{IN} = 6V-7V, I_{OUT} = 150mA$

Startup Through V_{IN}
 $V_{IN} = 12V, I_{OUT} = 150mA$

Shutdown Through V_{IN}
 $V_{IN} = 12V, I_{OUT} = 150mA$

Short Circuit Entry
 $V_{IN} = 12V, I_{OUT} = 0mA$ to short circuit

Short Circuit Recovery
 $V_{IN} = 12V$, short circuit to $I_{OUT} = 0mA$

Short Circuit Steady State
 $V_{IN} = 12V$

OPERATION

The MP2013 is a linear regulator that supplies power to systems with high voltage batteries. It includes a wide 2.5V to 40V input range, low dropout voltage and low quiescent supply current.

The MP2013 provides wide variety of fixed output voltage options: 1.8V, 1.9V, 2.3V, 2.5V, 3.0V, 3.3V, 3.45V, 5.0V; and also provides the output adjustable option (from 1.215V to 15V).

The output adjustable version has an output that is adjustable from 1.215V to 15V with a simple resistor divider. It uses external feedback, allowing the user to set the output voltage with an external resistor divider. The typical FB pin voltage is 1.215V.

The regulator output current is internally limited and the device is protected against over-load and over-temperature conditions.

The peak output current is limited to around 270mA, which exceeds the 150mA recommended continuous output current.

When the junction temperature is too high, the thermal sensor sends a signal to the control logic that will shutdown the IC. The IC will restart when the temperature has sufficiently cooled.

The maximum power output current is a function of the package's maximum power dissipation for a given temperature.

The maximum power dissipation is dependent on the thermal resistance of the case and the circuit board, the temperature difference between the die junction and the ambient air, and the rate of air flow. The GND pin and Exposed Pad must be connected to the ground plane for proper dissipation.

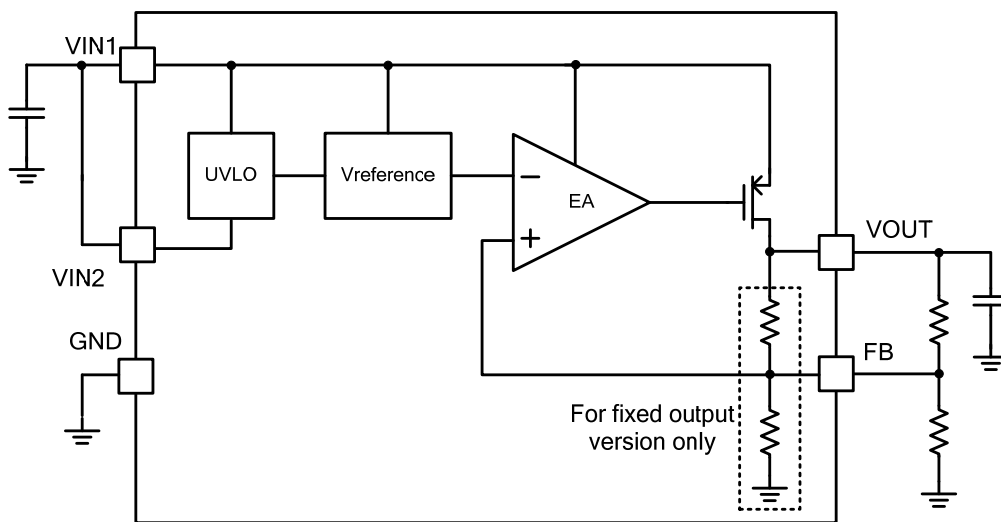

Figure 1: Functional Block Diagram

APPLICATION INFORMATION

COMPONENT SELECTION

Setting the Output Voltage

Set the output voltage of the MP2013 by using a resistor divider as shown:

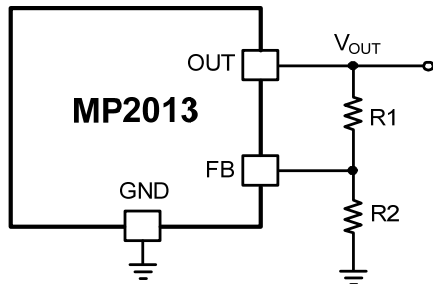

Figure 2: FB Resistor Divider to Set V_{OUT}

Choose $R2=1M\Omega$ to maintain a $1.215\mu A$ minimum load. Calculate the value for $R1$ using the following equation:

$$R1 = R2 \times \left(\frac{V_{OUT}}{1.215V} - 1 \right)$$

For fixed output version, V_{OUT} also can be adjusted by adding external resistor divider. Just note to take internal FB resistor divider into consideration when choose external divider.

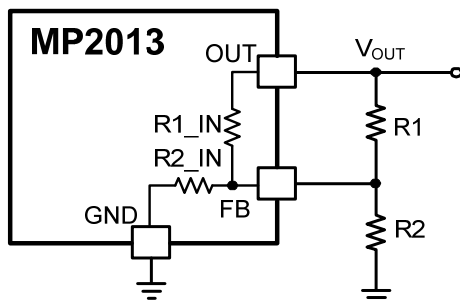

Figure 3: FB Divider of Fixed Output Version

The internal FB resistor dividers for different fixed output versions please see below table.

Table 1: Internal FB Resistor Divider

Fixed Output Voltage	R1_IN	R2_IN
3.3V	1.72M Ω	1M Ω

Input Capacitor

For proper operation, place a ceramic capacitor ($C1$) between $1\mu F$ and $10\mu F$ of dielectric type X5R or X7R between the input pin and ground. Larger values in this range will help improve line transient response.

Output Capacitor

For stable operation, use a ceramic capacitor ($C2$) of type X5R or X7R between $1\mu F$ and $10\mu F$. Larger values in this range will help improve load transient response and reduce noise. Output capacitors of other dielectric types may be used, but are not recommended as their capacitance can deviate greatly from their rated value over temperature.

To improve load transient response, add a small ceramic (X5R, X7R or Y5V dielectric) 22nF feed forward capacitor in parallel with $R1$. The feed forward capacitor is not required for stable operation.

OUTPUT NOISE

The MP2013 will exhibit noise on the output during normal operation. This noise is negligible for most applications. However, in applications that include analog-to-digital converters (ADCs) of more than 12 bits, one needs to consider the ADC's power supply rejection specifications. The feed forward capacitor $C2$ across $R1$ will significantly reduce the output noise.

External Reverse Voltage Protection

In some situations, e.g. a backup battery is connected as MP2013 load, the output voltage may be held up while the input is either pulled to ground, pulled to some intermediate voltage or is floating. Thus, the output voltage is higher than input voltage. Since the MP2013 PMOS pass element has a body diode, a current will conduct from the output to input and is not internally limited. It's possible that the IC will be damaged by this unlimited reverse current. To avoid this, it's recommended to place an external diode at input like below.

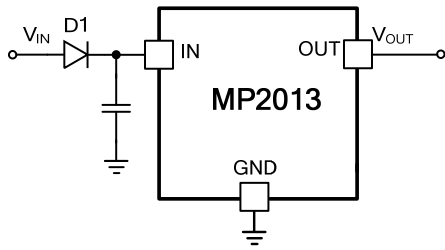
Figure 4: External Reverse Voltage Protection
PCB LAYOUT GUIDE

PCB layout is very important to achieve good regulation, ripple rejection, transient response and thermal performance. It is highly recommended to duplicate EVB layout for optimum performance.

If change is necessary, please follow these guidelines and take figure 5 for reference.

- 1) Input and output bypass ceramic capacitors are suggested to be put close to the IN Pin and OUT Pin respectively.
- 2) Ensure all feedback connections are short and direct. Place the feedback resistors and compensation components as close to the chip as possible.
- 3) Connect IN, OUT and especially GND respectively to a large copper area to cool the chip to improve thermal performance and long-term reliability.

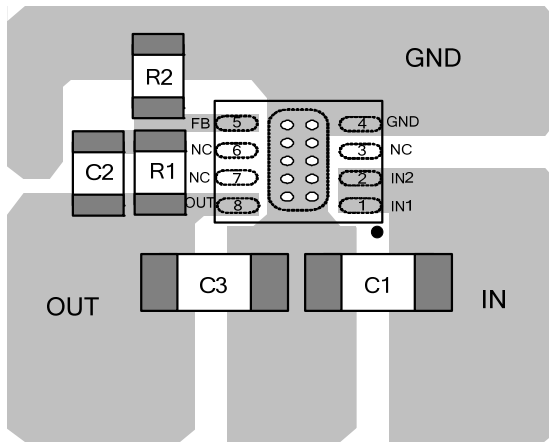
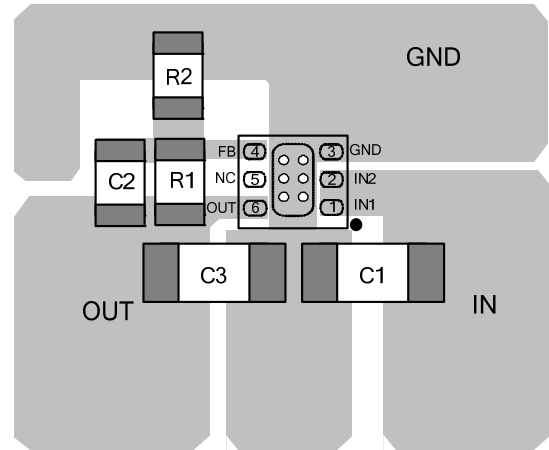
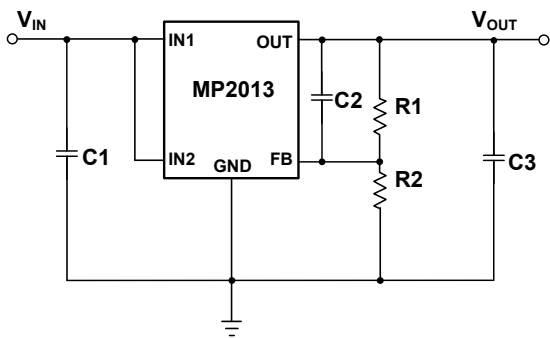
Figure 5: PCB Layout (Top Layer)

DESIGN EXAMPLE

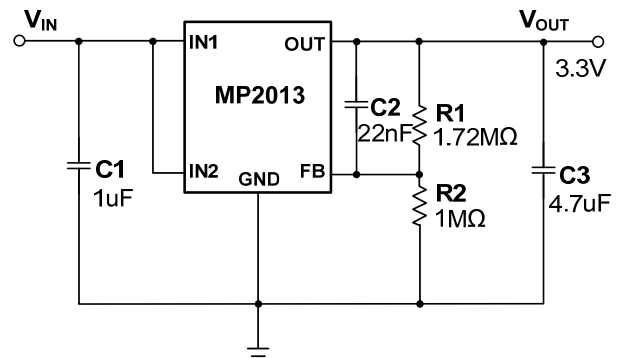
Below is a design example following the application guidelines for $V_{OUT}=3.3V$ with feedforward cap.

Figure 6: Design Example

TYPICAL APPLICATION CIRCUITS

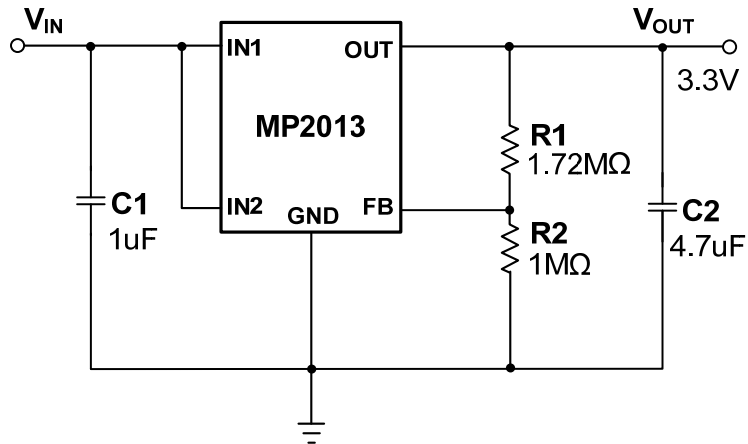

Figure 7: 3.3V Output Typical Application Circuit

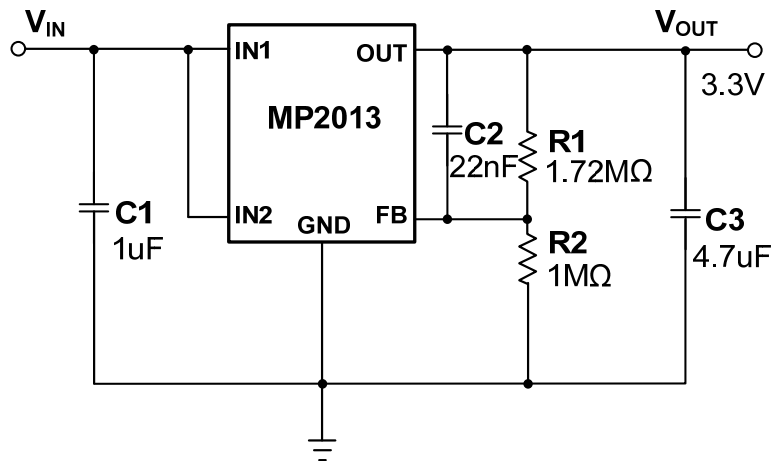

Figure 8: 3.3V Output with Feedforward Capacitor

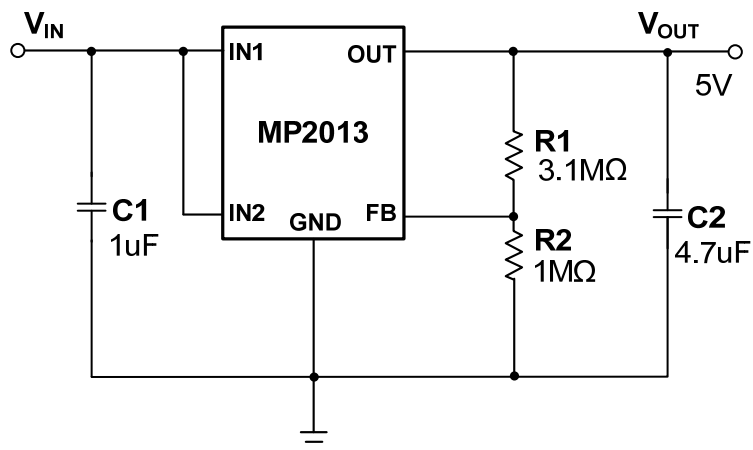
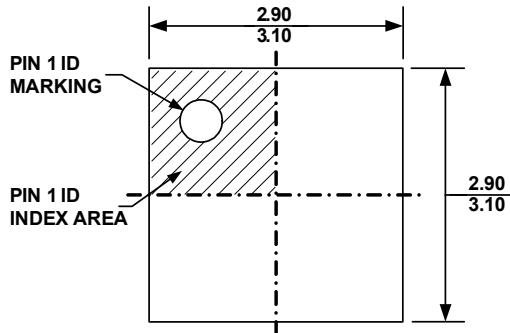

Figure 9: 5V Output Typical Application Circuit

PACKAGE INFORMATION

QFN8 (3mmx3mm)



TOP VIEW

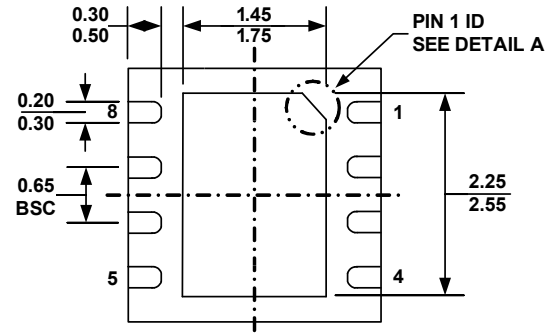

BOTTOM VIEW

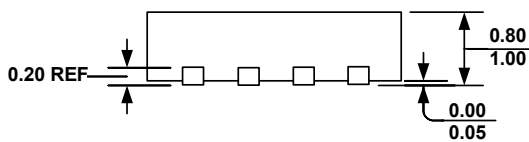

SIDE VIEW

PIN 1 ID OPTION A
0.30x45° TYP.

PIN 1 ID OPTION B
R0.20 TYP.

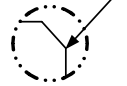

DETAIL A

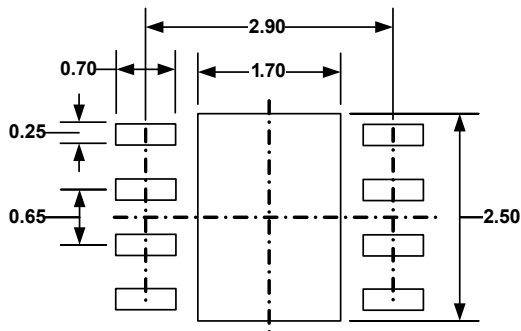

RECOMMENDED LAND PATTERN

NOTE:

- 1) ALL DIMENSIONS ARE IN MILLIMETERS
- 2) EXPOSED PADDLE SIZE DOES NOT INCLUDE MOLD FLASH
- 3) LEAD COPLANARITY SHALL BE 0.10 MILLIMETER MAX
- 4) JEDEC REFERENCE IS MO-229, VARIATION VEEC-2.
- 5) DRAWING IS NOT TO SCALE

PACKAGE INFORMATION (continued)

QFN6 (2mmx2mm)

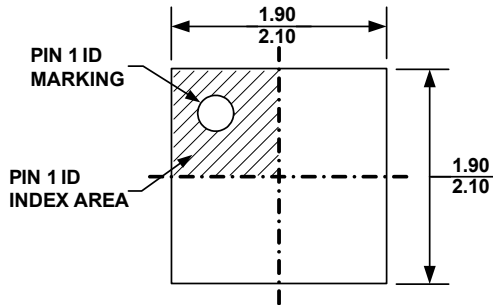

TOP VIEW

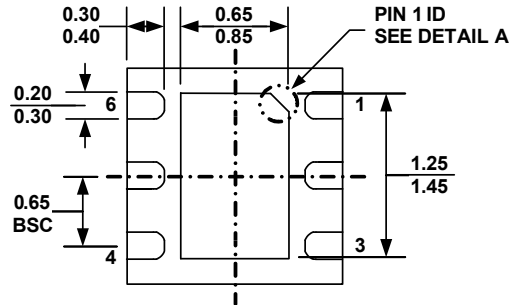

BOTTOM VIEW

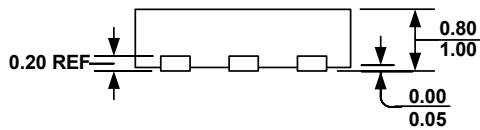

SIDE VIEW

PIN 1 ID OPTION A
0.30x45° TYP.

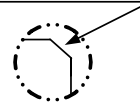

PIN 1 ID OPTION B
R0.20 TYP.

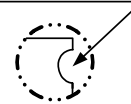

DETAIL A

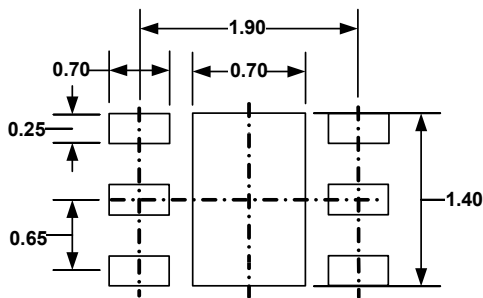

RECOMMENDED LAND PATTERN

NOTE:

- 1) ALL DIMENSIONS ARE IN MILLIMETERS
- 2) EXPOSED PADDLE SIZE DOES NOT INCLUDE MOLD FLASH
- 3) LEAD COPLANARITY SHALL BE 0.10 MILLIMETER MAX
- 4) JEDEC REFERENCE IS MO-229, VARIATION VCCC.
- 5) DRAWING IS NOT TO SCALE

REVISION HISTORY

Revision #	Revision Date	Description	Pages updated
1.0	10/16/2013	Initial Release	-
1.1	9/30/2021	Updated the footnote below the Applications section; removed TSOT23-5 package information	1
		Removed MP2013GJ orderable SKU information; removed TSOT23-5 package information	2
		Removed TSOT23-5 package information	5
		Removed TSOT23-5 package information	14
		Grammar and formatting updates	All

Notice: The information in this document is subject to change without notice. Please contact MPS for current specifications. Users should warrant and guarantee that third party Intellectual Property rights are not infringed upon when integrating MPS products into any application. MPS will not assume any legal responsibility for any said applications.