

# CMD67-21 Series PLCC-2 Package Surface Mount LED

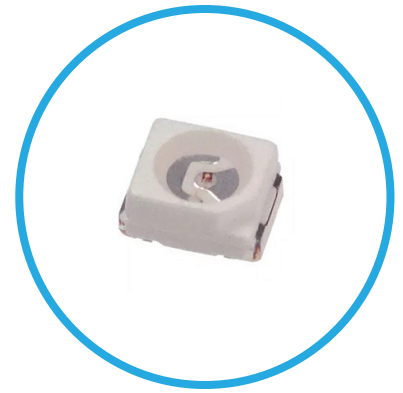

CMD67-21 Series features a SMD LED with a high intensity light output and a clear lens

## Applications

- Wearable and Portable Devices
- Automotive Features
- Navigations Systems
- Home and Smart Appliance
- Backlit Keypads
- Medical Devices
- Health Care Application
- Industrial Control Systems
- Status Indicator

## Key Features

- Surface mount technology
- Tape and reel packaged for high-speed automatic insertion
- Convection and vapor-phase reflow compatible
- Compact form enables high density placement
- Packaged 2000 pieces per reel
- Leading edge LED optoelectronic performance
- Consistent high brightness
- Low current types available
- Exceptional reliability
- Stringent process controls assure quality
- Extensive qualification testing to meet strictest requirements
- Designed to permit easy post-reflow solder joint inspection
- Compliant with RoHS and REACH requirements

# Product Dimensions

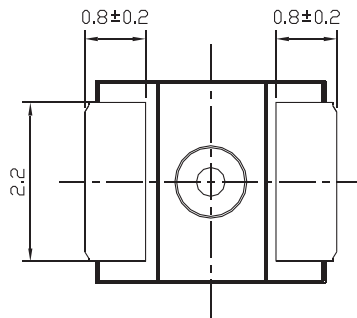
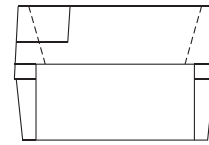
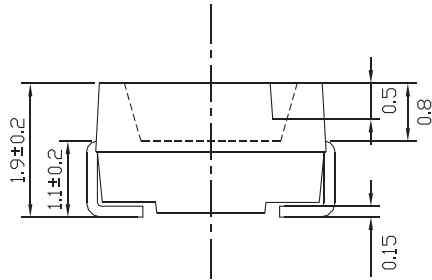
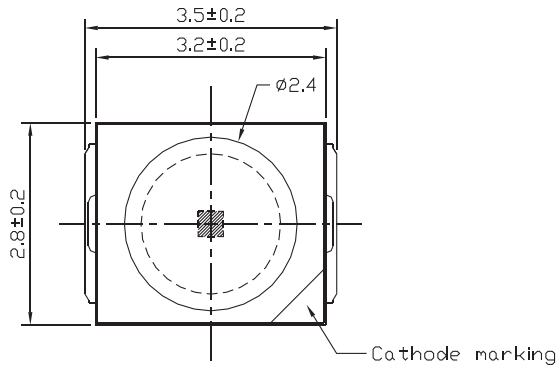

Recommended Solder Pad

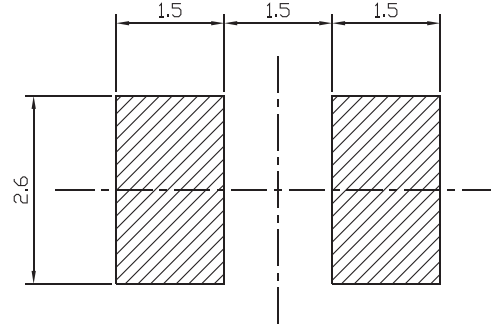

## Notes:

1. All dimensions are in mm
2. The tolerance unless mentioned is  $\pm 0.1$ mm

## Product Specifications

### Electrical-Optical Characteristics

Part Number	Emitted Color	Lens Color	Luminous Intensity		Forward Voltage		Polarity Mark Indicates	Peak Wavelength (nm)	Viewing Angle (degrees)
			Min. (mcd)	Typ. (mcd)	Typ. (V)	Max. (V)			
CMD67-21VGC/TR8	Green	Clear	15.0	25.0	2.1	2.8	Cathode	570	120
CMD67-21VYC/TR8	Yellow	Clear	6.0	10.0	2.0	2.8	Cathode	585	120
CMD67-21VRC/TR8	H.E. Red	Clear	6.0	10.0	2.0	2.4	Cathode	632	120
CMD67-21SRC/TR8	Bright Red	Clear	25.0	40.0	1.7	2.4	Anode	660	120
CMD67-21URC/TR8	Bright red	Clear	36.0	62.0	1.7	2.4	Anode	660	120

### Absolute Maximum Ratings

Emitted Color	Reverse Voltage (IR=100 $\mu$ A) (V)	Average Forward Current (mA)	Peak Forward Current (1 $\mu$ s @ 10% duty cycle) (mA)	Power Dissipation (mW)	Operating Temperature ( $^{\circ}$ C)	Storage Temperature ( $^{\circ}$ C)	Lead Solder Time at 260 $^{\circ}$ C (Seconds)
Green	5.0	25	150	105	-40 to +85	-40 to +85	5
H.E. Red	5.0	25	60	60	-40 to +85	-40 to +100	5
Yellow	5.0	30	150	105	-40 to +85	-40 to +85	5
Bright red	5.0	30	150	100	-40 to +85	-40 to +85	5

## Precautions

### • Over-current-proof

- Customer must apply resistors for protection, otherwise slight voltage shift will cause big current change ( Burn out will happen ).

### • Storage

- Do not open moisture proof bag before the products are ready to use.
- Before opening the package: The LEDs should be kept at 30°C or less and 90%RH or less.
- After opening the package: The LED's floor life is 168 hrs under 30°C or less and 60% RH or less. If unused LEDs remain, it should be stored in moisture proof packages.
- If the moisture absorbent material (silica gel) has faded away or the LEDs have exceeded the storage time, baking treatment should be performed using the following conditions. Baking treatment : 60±5°C for 24 hours.

### • Soldering Condition

- Pb-free solder temperature profile

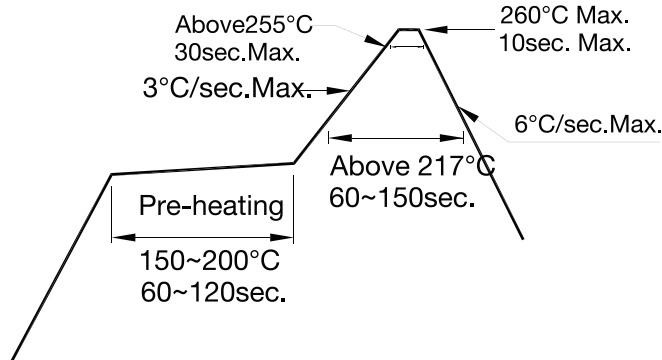

- Reflow soldering should not be done more than two times.
- When soldering, do not put stress on the LEDs during heating.
- After soldering, do not warp the circuit board.

### • Soldering Iron

- Each terminal is to go to the tip of soldering iron temperature less than 350°C for 3 seconds within once in less than the soldering iron capacity 25W. Leave two seconds and more intervals, and do soldering of each terminal. Be careful because the damage of the product is often started at the time of the hand solder.

### • Repairing

- Repair should not be done after the LEDs have been soldered. When repairing is unavoidable, a double-head soldering iron should be used (as below figure). It should be confirmed beforehand whether the characteristics of the LEDs will or will not be damaged by repairing.

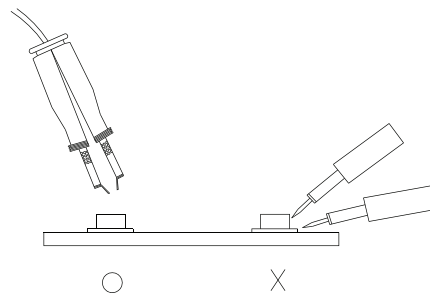

## Tape and Reel Dimensions

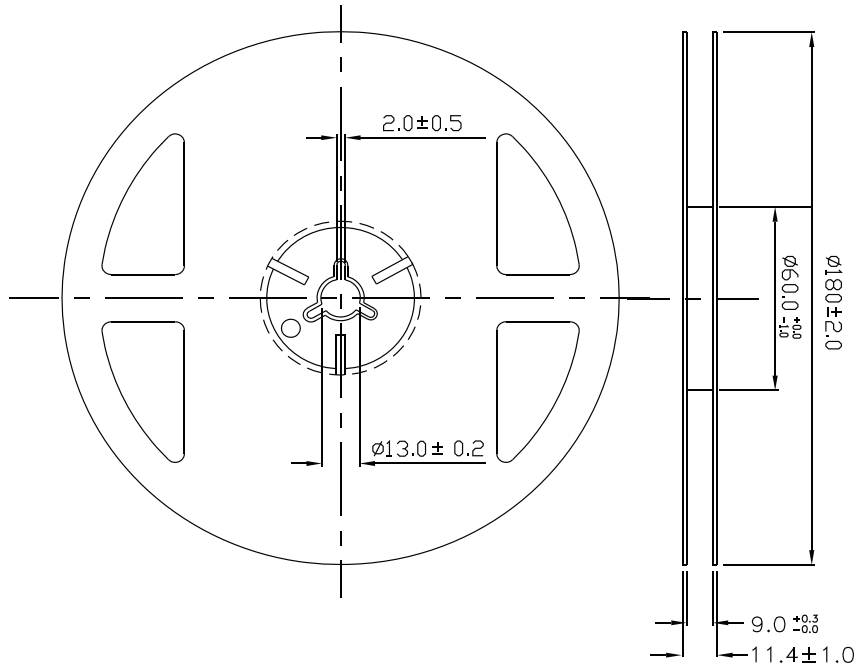

## Carrier Tape Dimensions: Loaded Quantity 2000 pcs Per Reel

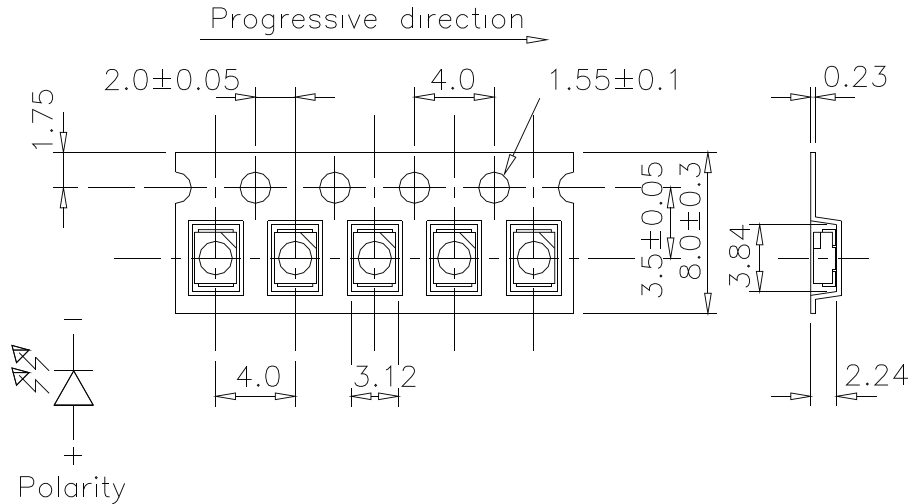

### Notes:

1. The tolerance unless mentioned is  $\pm 0.1\text{mm}$

## Compliances and Approvals

