

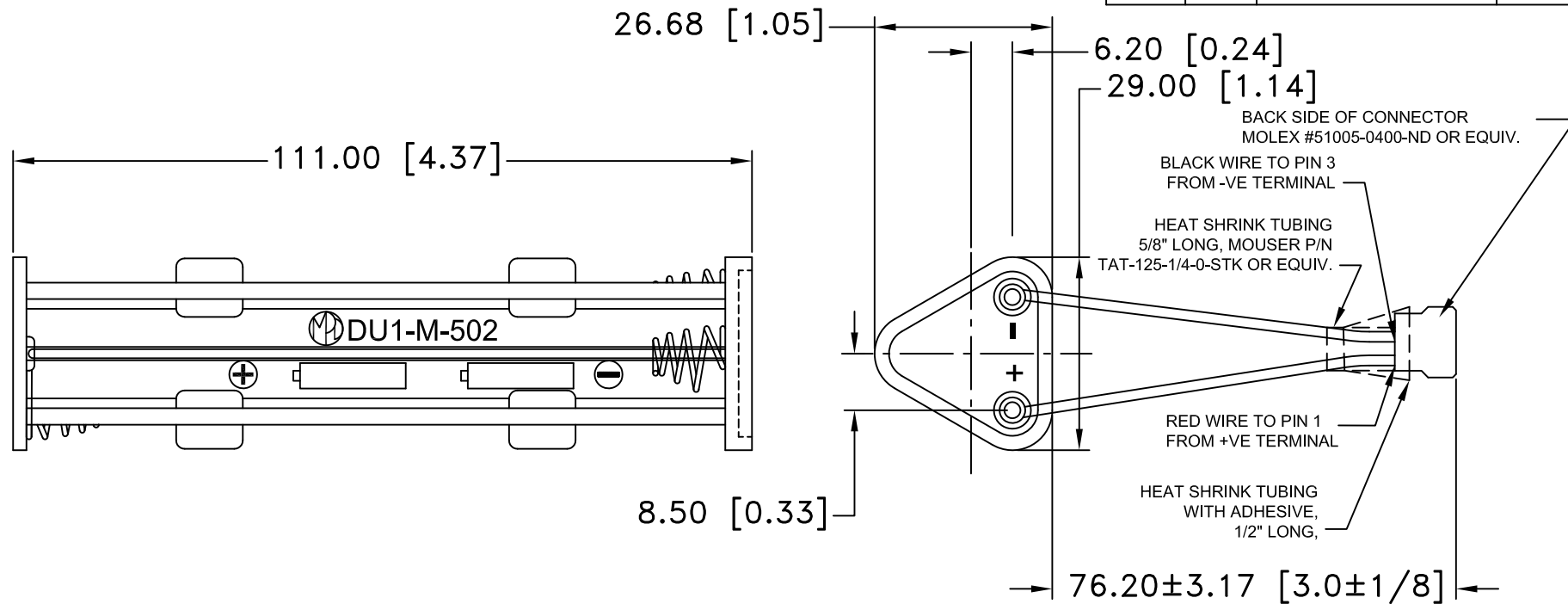

Date	SYM	REVISION RECORD	AUTH	DR.	CK.
10/08/05	C	Changed to Heat Shrink tubing w/adhesive	T.B.	B.S.	
11/05/05	D	Added note #9	T.B.	B.S.	
4/22/06	E	Added "ROHS COMPLIANT"	T.B.	B.S.	
12/05/14	F	Updated to ROHS 2 Compliant	T.B.	B.S.	



NOTES:

1. HOUSING: POLYPROPYLENE WITH 10% TALC.
2. LUGS: BRASS, NICKEL PLATED.
3. BUMP PLATES: MILD STEEL G3141 NICKEL PLATED.
4. EYELETS: BRASS, NICKEL PLATED.
5. SPRINGS: HARD DRAWN STEEL WIRE JIS G 3521 NICKEL PLATED.
6. WIRE: BLACK AND RED, 2 5/8 ± 1/8 LONG
7. CONNECTOR: MOLEX OR EQUIV.
MOLEX #51005-0400-ND OR EQUIV.
FEMALE 4-PIN CONNECTOR. PIN CENTERS=.079".
8. CONTACTS: MOLEX OR EQUIV.
MOLEX #50013
9. CRIMP TERMINAL CONNECTIONS FOR WIRES
10. ROHS 2 COMPLIANT

Tolerance (Except as noted)	 Memory Protection Devices, Inc 200 Broad Hollow Road, Farmingdale, New York 11735	Scale	Drawn By B.S.
		Approved By T.B.	
decimal ±.5 (.020)	Title SIX "AA" SIZE CELL BATTERY HOLDER		
Fractional ± .8 (.030)	Date 12/05/14	Drawing Number BK-5075	
Angular ± 3°			