

ISL98611

High Efficiency Display Power and LED Driver for Smart Phones

FN8662
Rev.4.00
Sep 13, 2017

The [ISL98611](#) is a high-efficiency display power supply and LED driver for small size displays, such as smart phones. It integrates a boost regulator, LDO, and inverting charge pump that are used to generate regulated positive and negative voltages for display power. It also integrates a boost regulator and 3-channel current sinks for the LED backlight driver. The positive and negative output voltages can be adjusted from $\pm 4.5V$ up to $\pm 6V$.

The ISL98611 extends the battery life of mobile devices by delivering greater than 88% efficiency for the display power function and up to 93% efficiency for the backlight driver when powering 12 LEDs. It reduces the PCB area by integrating the two functions into a single IC and by requiring only eight external components in total.

This product drives backlight LEDs with excellent current matching even at very low LED current ($\pm 2.2\%$ down to 1mA and $\pm 2.8\%$ at 50 μA), improving the brightness uniformity of LCD displays. It includes analog, PWM, and hybrid dimming to maximize LED efficiency while eliminating color shift issues.

The ISL98611 is offered in a 2.33x2.61mm² WLCSP package and the device is specified for operation across the -40°C to +85°C ambient temperature range.

Applications

- TFT-LCD Smart phone displays
- Small size/handheld display

Related Literature

- For a full list of related documents, visit our website - [ISL98611](#) product page

Features

- Display power output voltage: $\pm 5V$, $\pm 5.6V$
- Positive and negative voltages can be programmed from $\pm 4.5V$ to $\pm 6V$
- >88% efficiency with 12mA load between VP and VN
- Up to 93% efficient LED driver
- Only 8 external components; integrated compensation and feedback circuits
- Analog, PWM, and hybrid dimming
- $\pm 2.2\%$ current matching down to 1mA and $\pm 2.8\%$ at 50 μA
- Can drive 2 strings of LEDs
- 10-bit linear and 11-bit logarithmic DC output current control
- I²C, PWM, and SWIRE dimming inputs with internal multiplier for CABC
- 2.5V to 5V input voltage range
- VP and VN output adjustable from $\pm 4.5V$ up to $\pm 6V$ with 50mV steps
- I²C adjustable output voltages and settings
- 1 μA shutdown supply current
- RoHS compliant

TABLE 1. KEY DIFFERENCES BETWEEN PARTS

PART NUMBER	VP/VN OPTIONS (V)
ISL98611IIZ-T	± 5
ISL98611II56Z-T	± 5.6

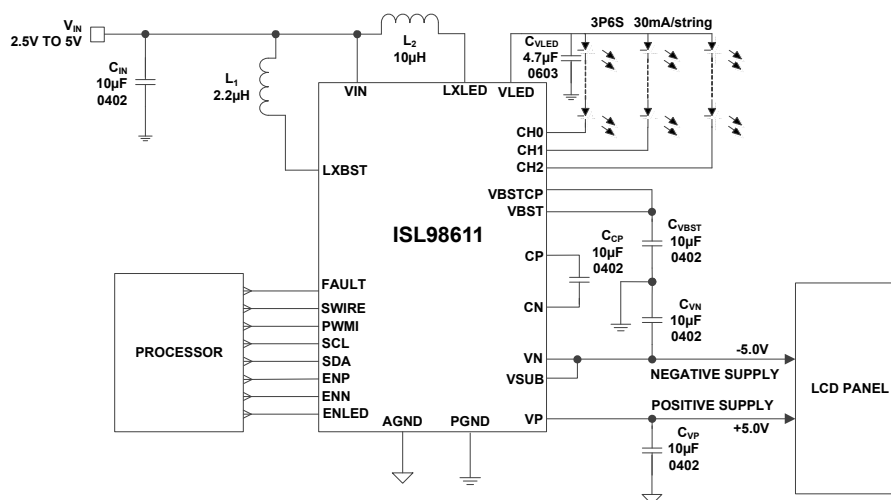

FIGURE 1. TYPICAL APPLICATION CIRCUIT FOR 3-CHANNEL LED DRIVER

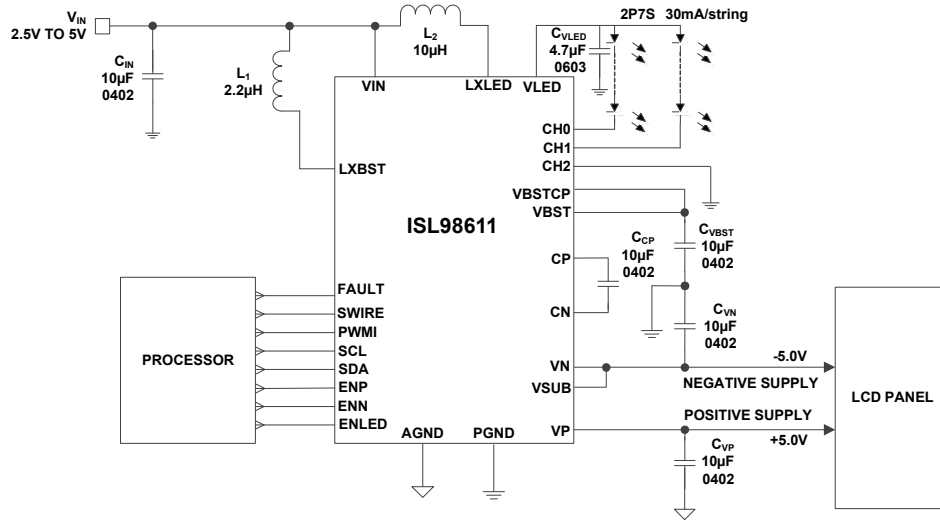

FIGURE 2. TYPICAL APPLICATION CIRCUIT FOR 2-CHANNEL LED DRIVER

© Copyright Intersil Americas LLC 2014-2017. All Rights Reserved.
 All trademarks and registered trademarks are the property of their respective owners.

For additional products, see www.intersil.com/en/products.html

Intersil products are manufactured, assembled and tested utilizing ISO9001 quality systems as noted in the quality certifications found at www.intersil.com/en/support/qualandreliability.html

Intersil products are sold by description only. Intersil may modify the circuit design and/or specifications of products at any time without notice, provided that such modification does not, in Intersil's sole judgment, affect the form, fit or function of the product. Accordingly, the reader is cautioned to verify that datasheets are current before placing orders. Information furnished by Intersil is believed to be accurate and reliable. However, no responsibility is assumed by Intersil or its subsidiaries for its use; nor for any infringements of patents or other rights of third parties which may result from its use. No license is granted by implication or otherwise under any patent or patent rights of Intersil or its subsidiaries.

For information regarding Intersil Corporation and its products, see www.intersil.com