

Features

- 0402 0.45mm SMD LED
- High Brightness
- AllnGaP / InGaN Technology
- Small package
- High reliability
- Clear Lens

Applications

- Consumer Electronics
- Wearables
- Automobile After Market
- Industrial Equipment

Description

The IN-S42AT series is a popular low profile 0402 package with versatile design capabilities. It is a PCB type molding style LED which can be used in various applications.

Recommended Solder Pattern

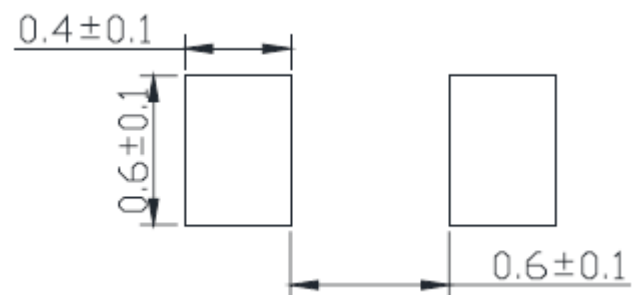

Figure 1. IN-S42AT Solder Pattern

Package Dimensions in mm

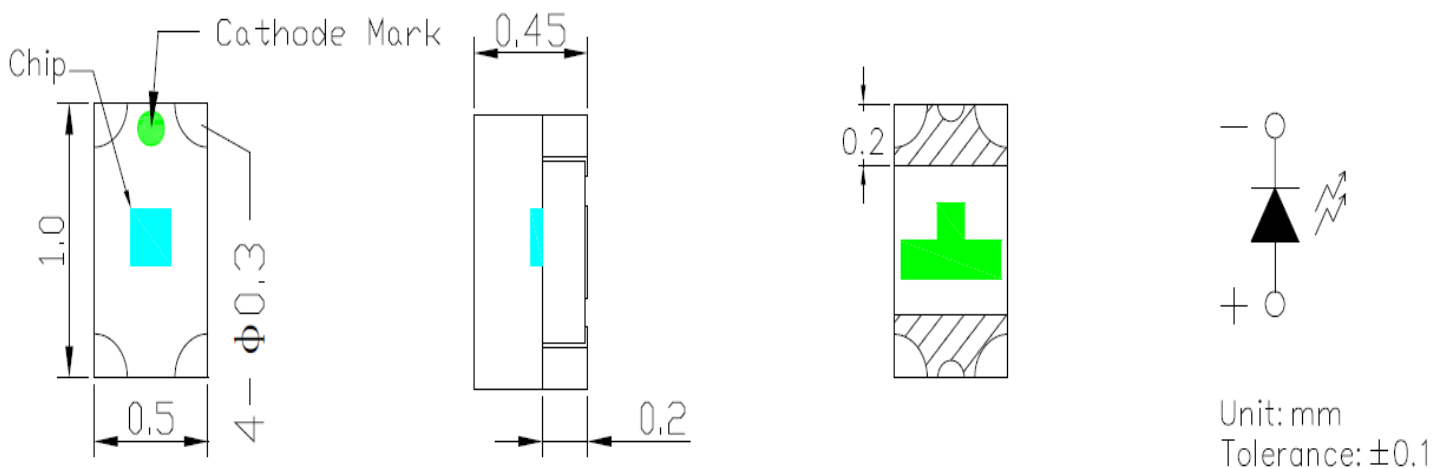

Figure 2. IN-S42AT Package Dimensions

Absolute Maximum Rating at 25°C (Note 1)

Product	Emission Color	P _d (mW)	I _F (mA)	I _{FP} * (mA)	V _R (V)	T _{OP} (°C)	T _{ST} (°C)
IN-S42ATYG	Yellow Green	78	25	100	5	-30°C~+80°C	-40°C~+85°C
IN-S42ATY	Yellow	78	25	100	5	-30°C~+80°C	-40°C~+85°C
IN-S42ATA	Amber	78	25	100	5	-30°C~+80°C	-40°C~+85°C
IN-S42ATR	Red	78	25	100	5	-30°C~+80°C	-40°C~+85°C
IN-S42ATB	Blue	100	25	100	5	-30°C~+80°C	-40°C~+85°C
IN-S42ATG	Green	100	25	100	5	-30°C~+80°C	-40°C~+85°C
IN-S42ATUW	White	100	25	100	5	-30°C~+80°C	-40°C~+85°C

Notes

1. Condition for IFP is pulse of 1/10 duty and 0.1msec width

ESD Precaution

ATTENTION: Electrostatic Discharge (ESD) protection



The symbol above denotes that ESD precaution is needed. ESD protection for GaP and AlGaAs based chips is necessary even though they are relatively safe in the presence of low static-electric discharge. Parts built with AlInGaP, GaN, or/and InGaN based chips are STATIC SENSITIVE devices. ESD precaution must be taken during design and assembly. If manual work or processing is needed, please ensure the device is adequately protected from ESD during the process.

Please be advised that normal static precautions should be taken in the handling and assembly of this device to prevent damage or degradation which may be induced by electrostatic discharge (ESD).

Electrical Characteristics $T_A = 25^\circ\text{C}$ (Note 1)

Product	Emission Color	$I_F(\text{mA})$	$V_F(\text{V})$		$\lambda(\text{nm})$			Viewing Angle	$I^*_v(\text{mcd})$
			typ.	max	λ_D	λ_P	$\Delta\lambda$	$2\theta_{1/2}$	typ.
IN-S42ATYG	Yellow Green	20	1.9	2.6	572	575	-	130	28.5
IN-S42ATY	Yellow	20	2.0	2.6	592	593	-	130	145
IN-S42ATA	Amber	20	2.1	2.6	605	610	-	130	145
IN-S42ATR	Red	20	2.1	2.6	631	645	-	130	90
IN-S42ATB	Blue	20	3.1	4.0	470	468	-	120	100
IN-S42ATG	Green	20	3.3	4.0	525	523	-	130	450
IN-S42ATUW	White	20	3.1	4.0	X=0.295 Y=0.30	-	-	130	600

Notes

1. Performance guaranteed only under conditions listed in above tables.

Chromaticity Bin (for White only)

BIN	CIE	Top	Right	Bottom	Left	BIN	CIE	Top	Right	Bottom	Left
R27	X	0.275	0.285	0.305	0.295	R28	X	0.28	0.29	0.31	0.3
	Y	0.27	0.28	0.28	0.27		Y	0.28	0.29	0.29	0.28
R29	X	0.285	0.295	0.315	0.305	R30	X	0.29	0.3	0.32	0.31
	Y	0.29	0.3	0.3	0.29		Y	0.3	0.31	0.31	0.3
R31	X	0.295	0.305	0.325	0.315						
	Y	0.31	0.32	0.32	0.31						

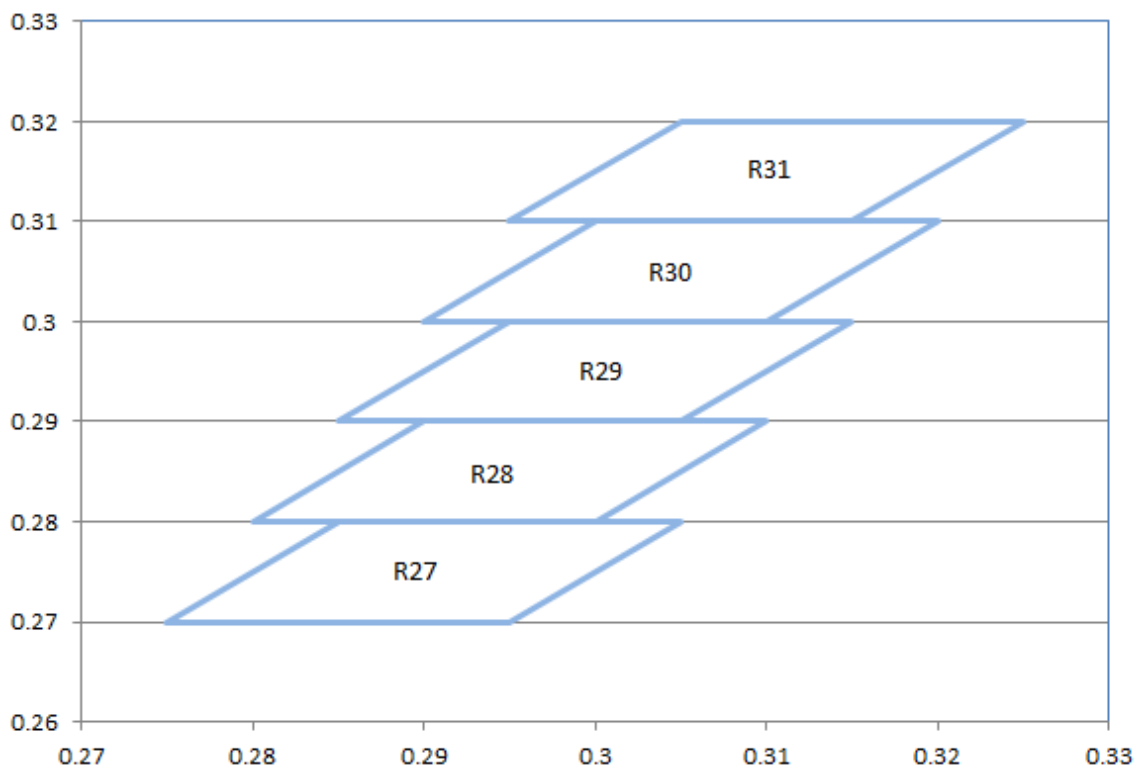

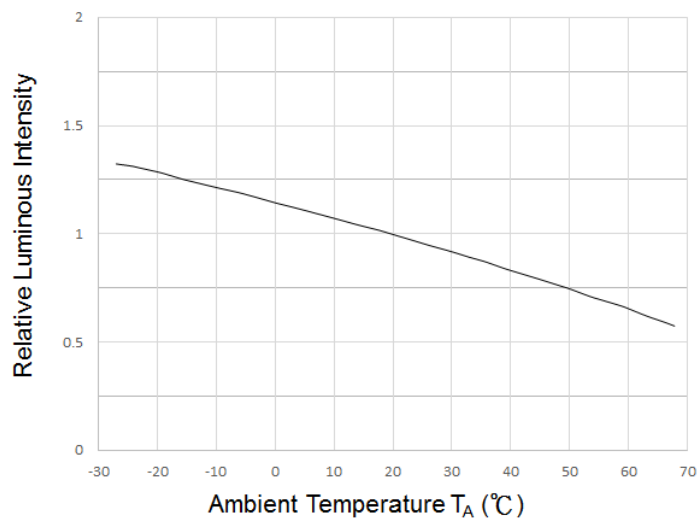
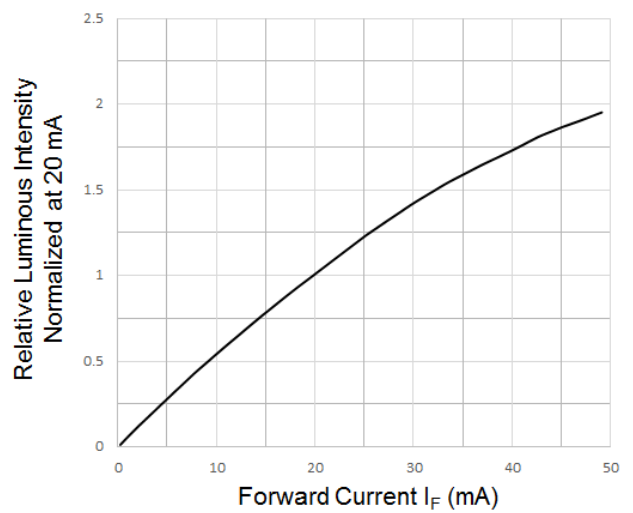
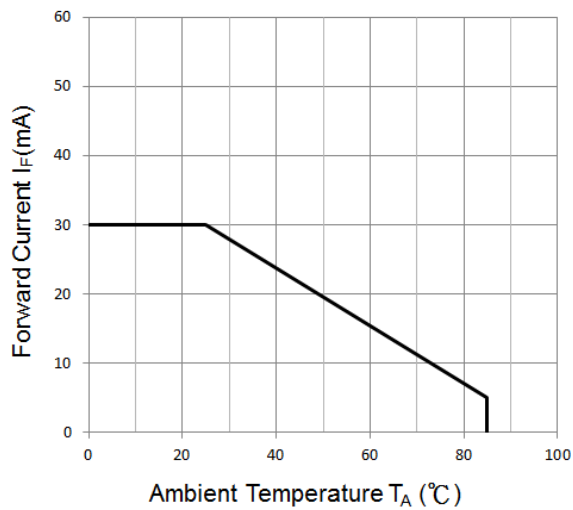
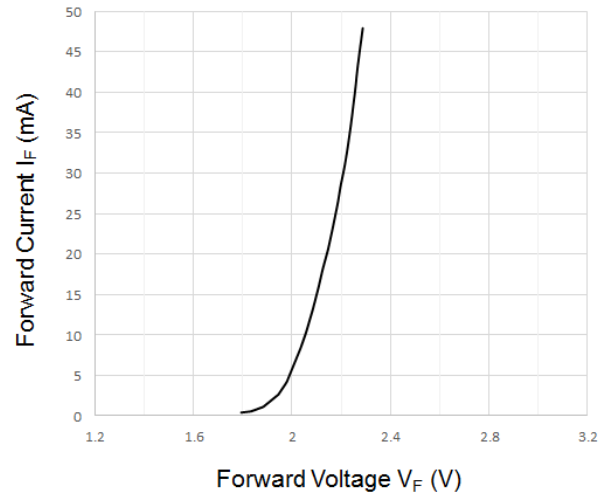
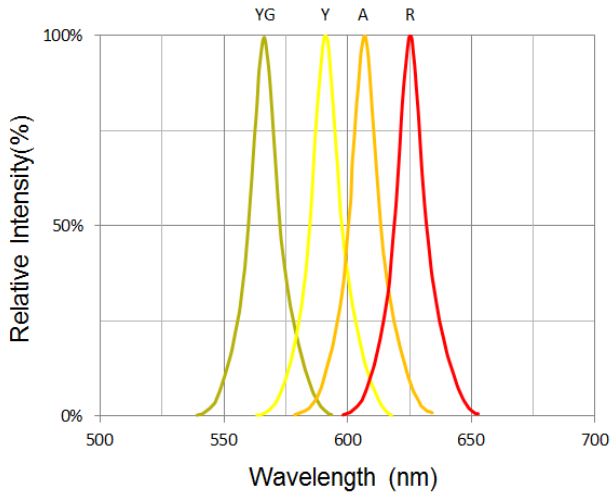
Typical Characteristic Curves – YG, Y, A, R

Typical Characteristic Curves – B, G, W

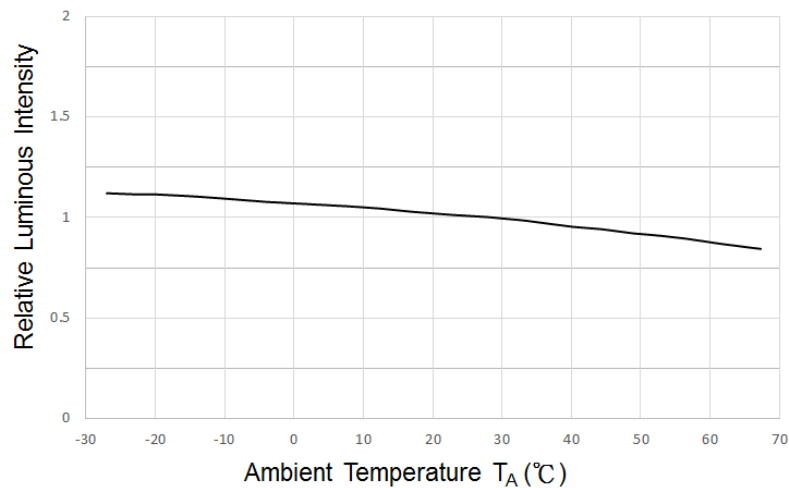
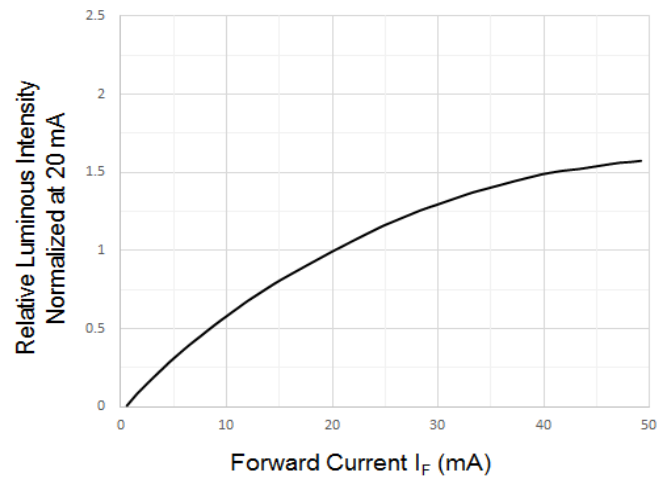
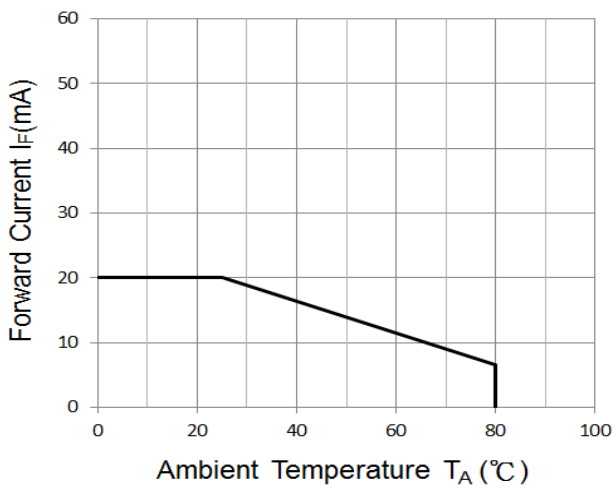
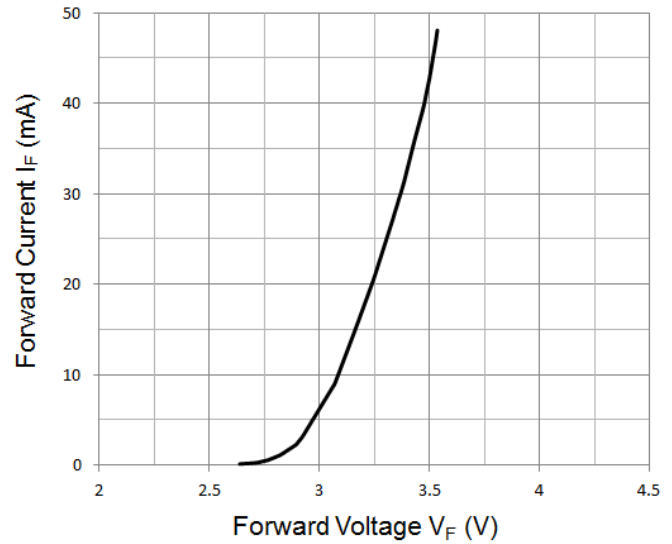
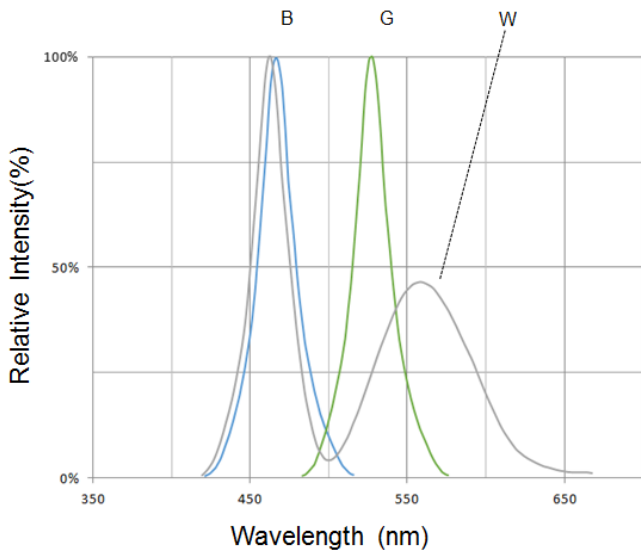

Typical Characteristic Curves – Radiation Pattern

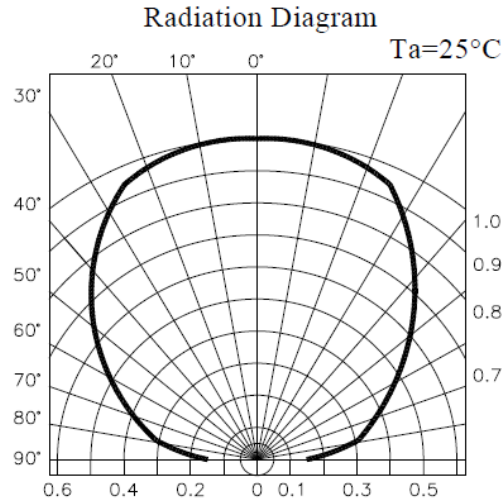

Ordering Information

Product	Emission Color	Technology	Test Current I_F (mA)	Luminous Intensity I_V (mcd) (Typ.)	Forward Voltage V_F (V) (Typ.)	Orderable Part Number
IN-S42ATYG	Yellow Green	AlInGaP	20	36	1.9	IN-S42ATYG
IN-S42ATY	Yellow	AlInGaP	20	90	2.0	IN-S42ATY
IN-S42ATA	Amber	AlInGaP	20	90	2.1	IN-S42ATA
IN-S42ATR	Red	AlInGaP	20	90	2.1	IN-S42ATR
IN-S42ATB	Blue	InGaN	20	100	3.1	IN-S42ATB
IN-S42ATG	Green	InGaN	20	360	3.3	IN-S42ATG
IN-S42ATUW	White	InGaN	20	600	3.1	IN-S42ATUW

Label Specifications

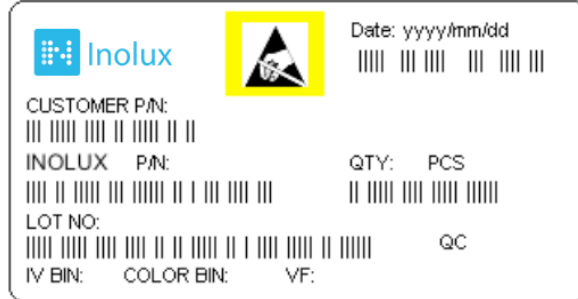

Inolux P/N:

I	N	-	S	4	2	A	T			X	-	X	X	X	X
Inolux SMD			Material	Package		Variation	Orientation	Current	Lens	Color		Customized Stamp-off			
			S = PCB Type	42A = 1.0 x 0.5 x 0.45mm			T = Top Mount	(Blank) = 20mA 5=5mA	(Blank) = Clear U = Diffused	R=645m A=610nm Y=593nm YG=575nm G=523nm B=468nm W=White					

Lot No.:

Z	2	0	1	7	01	24	001
Internal Tracker	Year (2017, 2018,)				Month	Date	Serial

Packaging Information: 5000pcs Per Reel
Tape Dimension

Packing Size													
Item	W	P1	E	F	Do	D1	Po	10Po	P2	Ao	Bo	Ko	T
Spec.	8.00	4.00	1.75	3.50	1.55	0.40	4.00	40.00	2.00	0.57	1.12	0.55	0.20
Tolerance	+0.30 -0.10	±0.10	±0.10	±0.05	±0.05	±0.1	±0.1	±0.20	±0.05	±0.03	±0.03	±0.03	±0.05

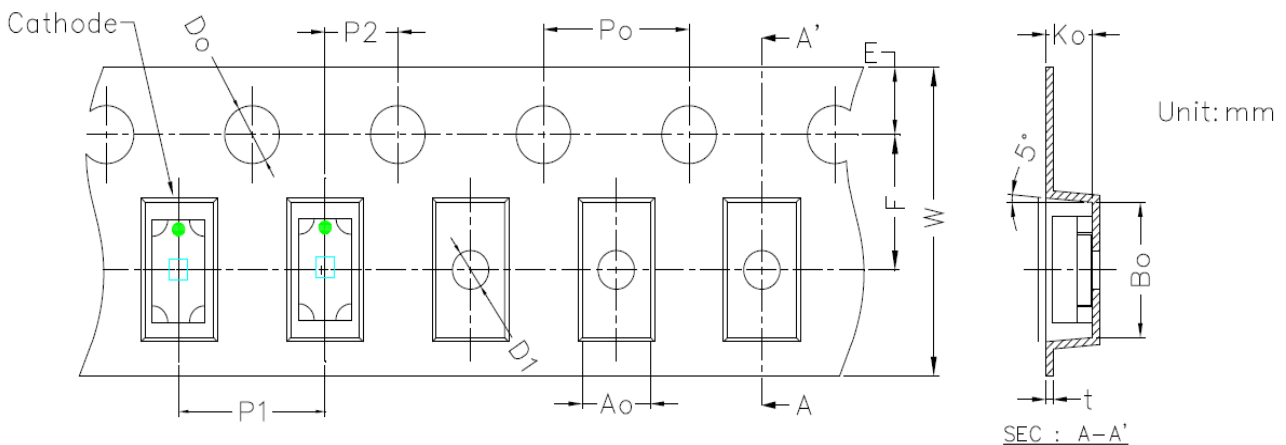
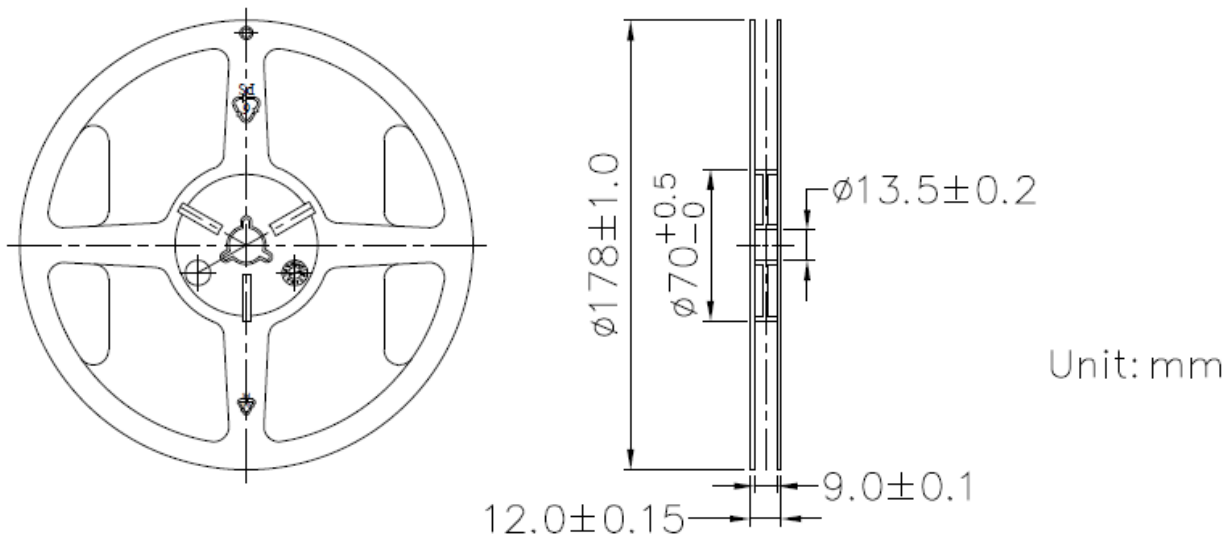
Reel Dimension

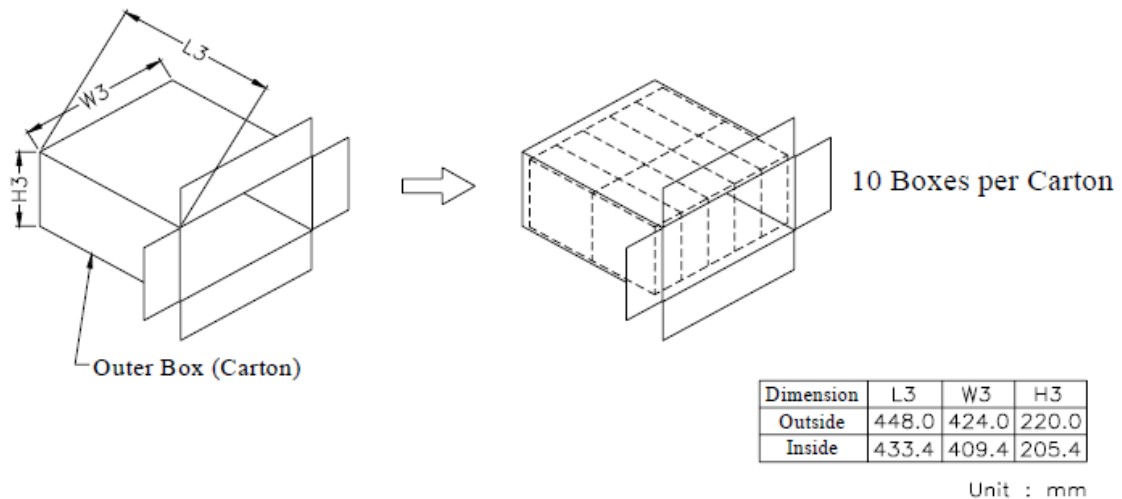
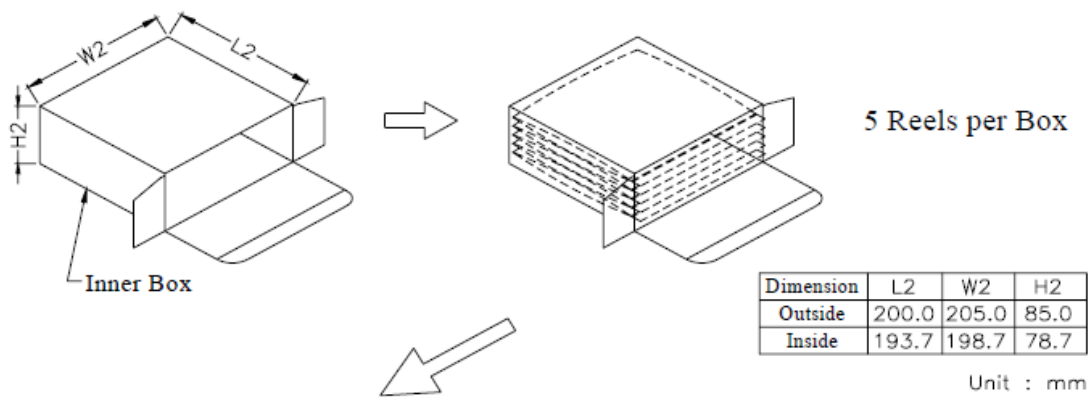
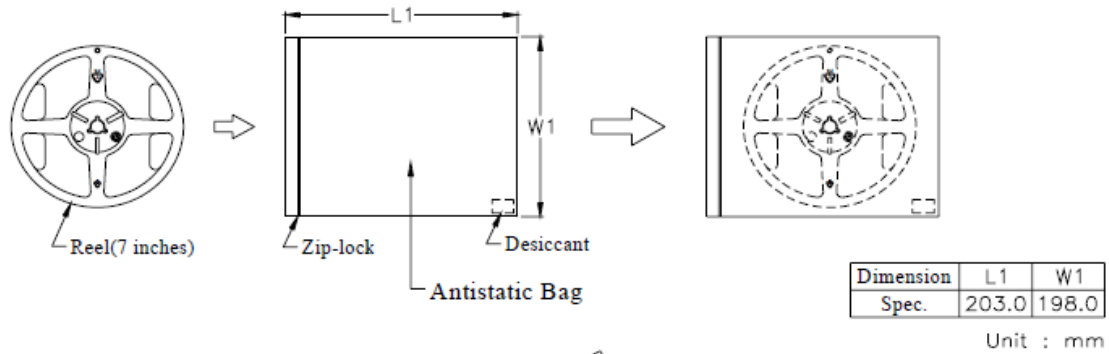
Packing Dimension

Dry Pack

All SMD optical devices are **MOISTURE SENSITIVE**. Avoid exposure to moisture at all times during transportation or storage. Every reel is packaged in a moisture protected anti-static bag. Each bag is properly sealed prior to shipment.

Upon request, a humidity indicator will be included in the moisture protected anti-static bag prior to shipment.

The packaging sequence is as follows:

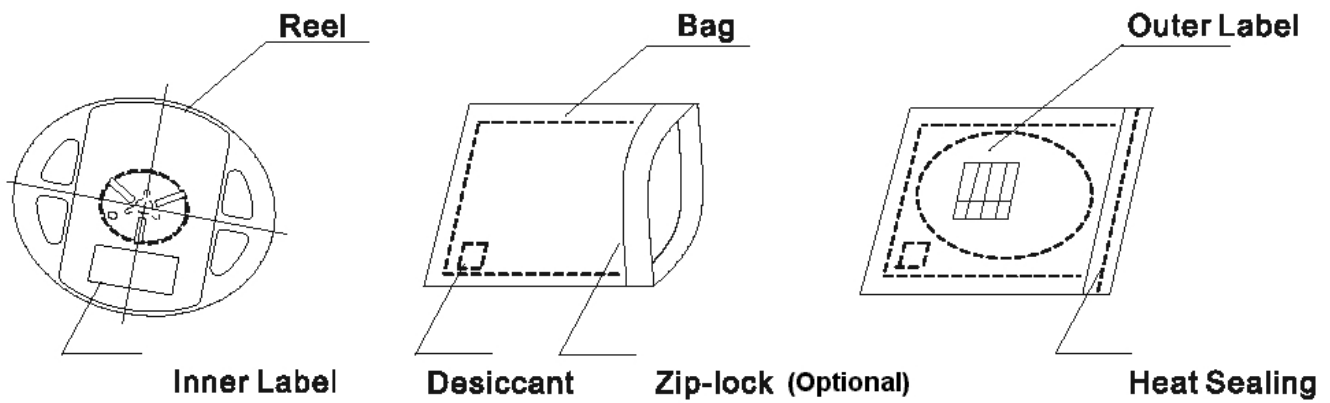

Reflow Soldering

- Recommended tin glue specifications: melting temperature in the range of 178~192 °C
- The recommended reflow soldering profile is as follows (temperatures indicated are as measured on the surface of the LED resin):

Lead-free Solder Profile

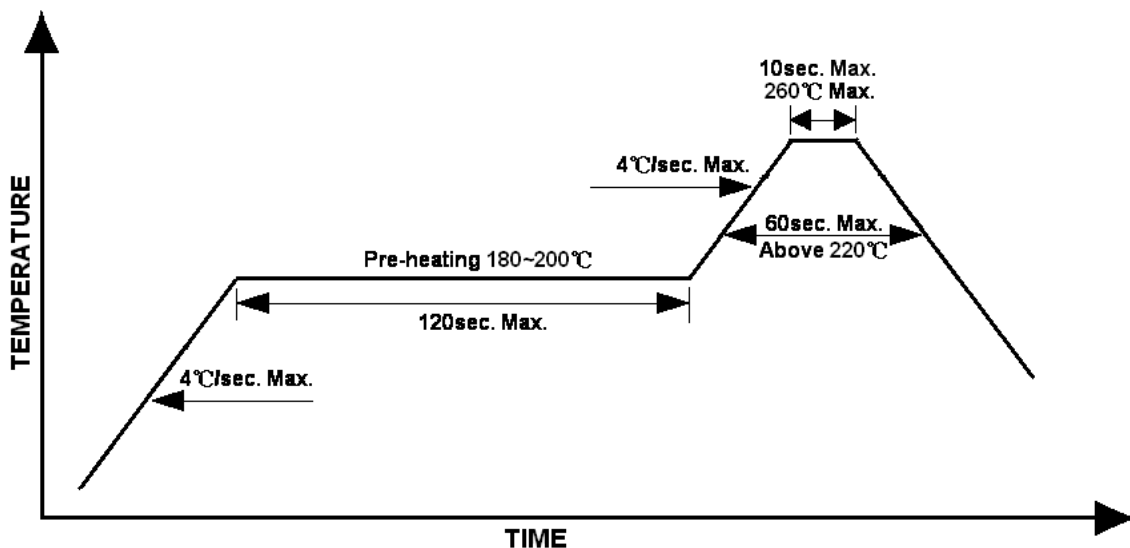

Precautions

- Avoid exposure to moisture at all times during transportation or storage.
- Anti-Static precaution must be taken when handling GaN, InGaN, and AlInGaP products.
- It is suggested to connect the unit with a current limiting resistor of the proper size. Avoid applying a reverse voltage.
- Avoid operation beyond the limits as specified by the absolute maximum ratings.
- Avoid direct contact with the surface through which the LED emits light.
- If possible, assemble the unit in a clean room or dust-free environment.

Reworking

- Rework should be completed within 5 seconds under 260 °C.
- The iron tip must not come in contact with the copper foil.
- Twin-head type is preferred.

Cleaning

Following are cleaning procedures after soldering:

- An alcohol-based solvent such as isopropyl alcohol (IPA) is recommended.
- Temperature x Time should be 50°C x 30sec. or <30°C x 3min
- Ultra sonic cleaning: < 15W/ bath; bath volume ≤ 1liter
- Curing: 100 °C max, <3min

Cautions of Pick and Place

- Avoid stress on the resin at elevated temperature.
- Avoid rubbing or scraping the resin by any object.
- Electro-static may cause damage to the component. Please ensure that the equipment is properly grounded. Use of an ionizer fan is recommended.

Reliability

Item	Frequency/ lots/ samples/ failures	Standards Reference	Conditions
Precondition	For all reliability monitoring tests according to JEDEC Level 2	J-STD-020	1.) Baking at 85°C for 24hrs 2.) Moisture storage at 85°C/ 60% R.H. for 168hrs
Solderability	1Q/ 1/ 22/ 0	JESD22-B102-B And CNS-5068	Accelerated aging 155°C/ 24hrs Tinning speed: 2.5+0.5cm/s Tinning: A: 215°C/ 3+1s or B: 260°C/ 10+1s
Resistance to soldering heat		CNS-5067	Dipping soldering terminal only Soldering bath temperature A: 260+/-5°C; 10+/-1s B: 350+/-10°C; 3+/-0.5s
Operating life test	1Q/ 1/ 40/ 0	CNS-11829	1.) Precondition: 85°C baking for 24hrs 85°C/ 60%R.H. for 168hrs 2.) Tamb25°C; IF=20mA; duration 1000hrs
High humidity, high temperature bias	1Q/ 1/ 45/ 0	JESD-A101-B	Tamb: 85°C Humidity: 85% R.H., IF=5mA Duration: 1000hrs
High temperature bias	1Q/ 1/ 20	IN specs.	Tamb: 55°C IF=20mA Duration: 1000hrs
Pulse life test	1Q/ 1/ 40/ 0		Tamb25°C, If=20mA,, Ip=100mA, Duty cycle=0.125 (tp=125 μs, T=1sec) Duration 500hrs)
Temperature cycle	1Q/ 1/ 76/ 0	JESD-A104-A IEC 68-2-14, Nb	A cycle: -40 degree C 15min; +85 degree C 15min Thermal steady within 5 min.. 300 cycles 2 chamber/ Air-to-air type
High humidity storage test	1Q/ 1/ 40/ 0	CNS-6117	60+3°C 90+5/-10% R.H. for 500hrs
High temperature storage test	1Q/ 1/ 40/ 0	CNS-554	100+10°C for 500hrs
Low temperature storage test	1Q/ 1/ 40/ 0	CNS-6118	-40+5°C for 500hrs

Revision History

Changes since last revision	Page	Version No.	Revision Date
Initial Release		1.0	02-07-2017
Format Update		1.1	04-25-2017

DISCLAIMER

INOLUX reserves the right to make changes without further notice to any products herein to improve reliability, function or design. INOLUX does not assume any liability arising out of the application or use of any product or circuit described herein; neither does it convey any license under its patent rights, nor the rights of others.

LIFE SUPPORT POLICY

INOLUX's products are not authorized for use as critical components in life support devices or systems without the express written approval of the President of INOLUX or INOLUX CORPORATION. As used herein:

1. Life support devices or systems are devices or systems which, (a) are intended for surgical implant into the body, or (b) support or sustain life, and (c) whose failure to perform when properly used in accordance with instructions for use provided in the labeling, can be reasonably expected to result in a significant injury of the user.
2. A critical component in any component of a life support device or system whose failure to perform can be reasonably expected to cause the failure of the life support device or system, or to affect its safety or effectiveness.