

# MGJ6 Full Bridge Series

5.7kVDC Isolated 6W Triple Output Gate Drive SM DC-DC Converters

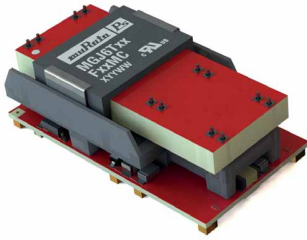

## FEATURES

- No opto feedback
- Patent protected
- Three isolated output voltages suitable for IGBT/SiC & Mosfet gate drives in a full bridge configuration
- Reinforced insulation to UL60950 with 8mm creepage & clearance recognised
- ANSI/AAMI ES60601-1, 2 MOPP recognised
- Characterised CMTI >100kV/μS
- Characterised partial discharge performance
- 5.7kVDC isolation test voltage 'Hi Pot Test'
- Ultra low isolation capacitance typically 15pF
- Continuous barrier withstand voltage 3kVDC
- 5V, 12V & 24V input voltages
- 105°C operating temperature

## PRODUCT OVERVIEW

Offering Three isolated output voltages of 24V, the MGJ6-FB series of DC-DC converters is ideal for simultaneously powering 'high side' and 'low side' gate drive circuits for IGBTs, Silicon and Silicon Carbide Mosfets in full bridge circuits. The MGJ6-FB series is characterised for high isolation and dv/dt requirements commonly seen in bridge circuits used in motor drives and inverters.

## SELECTION GUIDE

| Order Code <sup>1</sup> | Input Voltage Range | Output 1 VHA / Output 2 VHB |                      |              | Output 3 VL          |                      |              |
|-------------------------|---------------------|-----------------------------|----------------------|--------------|----------------------|----------------------|--------------|
|                         |                     | Rated Output Voltage        | Rated Output Current | Output Power | Rated Output Voltage | Rated Output Current | Output Power |
|                         |                     | V                           | mA                   | W            | V                    | mA                   | W            |
| MGJ6T05F24MC            | 4.5 - 9             | 24                          | 62.5                 | 1.5          | 24                   | 125                  | 3            |
| MGJ6T12F24MC            | 9 - 18              | 24                          | 62.5                 | 1.5          | 24                   | 125                  | 3            |
| MGJ6T24F24MC            | 18 - 36             | 24                          | 62.5                 | 1.5          | 24                   | 125                  | 3            |

## SELECTION GUIDE (Continued)

| Order Code <sup>1</sup> | Input Voltage Range | Output 1 VHA / Output 2 VHB        |                                    |                                   |                                   | Output 3 VL           |                       |                                   |                                   |
|-------------------------|---------------------|------------------------------------|------------------------------------|-----------------------------------|-----------------------------------|-----------------------|-----------------------|-----------------------------------|-----------------------------------|
|                         |                     | Load Regulation (Typ) <sup>4</sup> | Load Regulation (Max) <sup>4</sup> | Ripple & Noise (Typ) <sup>2</sup> | Ripple & Noise (Max) <sup>2</sup> | Load Regulation (Typ) | Load Regulation (Max) | Ripple & Noise (Typ) <sup>2</sup> | Ripple & Noise (Max) <sup>2</sup> |
|                         |                     | %                                  | %                                  | mVp-p                             | mVp-p                             | %                     | %                     | mVp-p                             | mVp-p                             |
| MGJ6T05F24MC            | 4.5 - 9             | 2                                  | 3                                  | 100                               | 150                               | 2                     | 3                     | 100                               | 150                               |
| MGJ6T12F24MC            | 9 - 18              | 2                                  | 3                                  | 150                               | 200                               | 2                     | 3                     | 150                               | 200                               |
| MGJ6T24F24MC            | 18 - 36             | 2                                  | 3                                  | 150                               | 200                               | 2                     | 3                     | 150                               | 200                               |

## SELECTION GUIDE (Continued)

| Order Code <sup>1</sup> | Nominal Input Voltage | Input Current at Rated Load | Efficiency (Min) | Efficiency (Typ) | MTTF <sup>3</sup> |            |
|-------------------------|-----------------------|-----------------------------|------------------|------------------|-------------------|------------|
|                         |                       |                             |                  |                  | MIL-217           | Telecordia |
|                         |                       |                             |                  |                  | kHrs              |            |
| MGJ6T05F24MC            | 5                     | 1500                        | 76               | 80               | 686               | 2706       |
| MGJ6T12F24MC            | 12                    | 600                         | 81               | 84               | 885               | 1971       |
| MGJ6T24F24MC            | 24                    | 300                         | 82               | 85               | 885               | 1917       |



For full details go to [www.murata-ps.com/rohs](http://www.murata-ps.com/rohs)



1. Components are supplied in tape and reel packaging, please refer to tape and reel specification section. Orderable part numbers are MGJ6TXXF24MC-R7 (23 pieces per reel), or MGJ6TXXF24MC-R13 (92 pieces per reel).
  2. See ripple & noise test method.
  3. Calculated using MIL-HDBK-217 FN2 and Telecordia SR-332 calculation model at T<sub>A</sub>=25°C with nominal input voltage at full load.
  4. Between 50% and 100% rated output current.
- All specifications typical at T<sub>A</sub>=25°C, nominal input voltage and rated output current unless otherwise specified.

| INPUT CHARACTERISTICS  |                            |      |      |      |           |
|------------------------|----------------------------|------|------|------|-----------|
| Parameter              | Conditions                 | Min. | Typ. | Max. | Units     |
| Voltage range          | 5V input types             | 4.5  | 5    | 9    | V         |
|                        | 12V input types            | 9    | 12   | 18   |           |
|                        | 24V input types            | 18   | 24   | 36   |           |
| Under voltage lock out | Turn on threshold MGJ6T05  |      | 3.8  |      | V         |
|                        | Turn off threshold MGJ6T05 |      | 3.2  |      |           |
|                        | Turn on threshold MGJ6T12  |      | 8.1  |      |           |
|                        | Turn off threshold MGJ6T12 |      | 7.5  |      |           |
|                        | Turn on threshold MGJ6T24  |      | 16.7 |      |           |
|                        | Turn off threshold MGJ6T24 |      | 16.3 |      |           |
| Input ripple current   | 5V input types             |      | 30   |      | mA<br>p-p |
|                        | 12V input types            |      | 45   |      |           |
|                        | 24V input types            |      | 30   |      |           |

| OUTPUT CHARACTERISTICS     |  |      |         |      |       |
|----------------------------|--|------|---------|------|-------|
| Parameter                  | Conditions   | Min. | Typ.    | Max. | Units |
| Minimum load               | Below 10% load, output may rise to 30V maximum voltage | 10   |         |      | %     |
| Voltage set point accuracy | All output types                                       |      | +3 / -2 |      | %     |
| Total regulation           |  |      |         | 10   | %     |
| Line regulation            | Low line to high line                                  |      | 0.5     | 1    | %     |

| GENERAL CHARACTERISTICS |                        |      |      |      |       |
|-------------------------|------------------------|------|------|------|-------|
| Parameter               | Conditions             | Min. | Typ. | Max. | Units |
| Power Consumption       | Disable pin pulled low |      | 45   |      | mW    |
| Switching frequency     |                        |      | 100  |      | kHz   |

| ISOLATION CHARACTERISTICS            |  |            |      |      |       |
|--------------------------------------|--|------------|------|------|-------|
| Parameter                            | Conditions   | Min.       | Typ. | Max. | Units |
| Isolation test voltage               | Flash tested for 1 second (input to output)          | 4000       |      |      | VAC   |
|                                      | Flash tested for 1 second (output to output)         | 2500       |      |      |       |
|                                      | Qualification tested for 1 minute (input to output)  | 5700       |      |      | VDC   |
|                                      | Qualification tested for 1 minute (output to output) | 3000       |      |      |       |
| Resistance                           | Viso = 1kVDC   | 100        |      |      | GΩ    |
| Continuous barrier withstand voltage | Non-safety barrier application                       |            |      | 3000 | VDC   |
| Safety standard                      | UL60950-1  | Reinforced |      | 250  | Vrms  |
|                                      | ANSI/AAMI ES60601-1                                  | 2 MOPP     |      | 250  |       |
| Creepage & clearance                 | Input to output                                      |            |      | 8    | mm    |
|                                      | Output to output                                     |            |      | 8    |       |
| Isolation capacitance                | Primary to Output 1 VHA                              |            | 15   |      | pF    |
|                                      | Primary to Output 2 VHB                              |            | 15   |      |       |
|                                      | Primary to Output 3 VL                               |            | 15   |      |       |

| TEMPERATURE CHARACTERISTICS            |  |                       |      |      |       |
|--|--|-----------------------|------|------|-------|
| Parameter                              | Conditions                                 | Min.                  | Typ. | Max. | Units |
| Operation                              | See derating graphs                        | -40                   |      | 105  | °C    |
| Storage                                |  | -55                   |      | 125  |       |
| Product temperature rise above ambient | 100% Load, Nom V <sub>in</sub> , Still Air | 5V input types        | 25   |      |       |
|  |  | All other input types | 19   |      |       |

| ABSOLUTE MAXIMUM RATINGS               |            |
|--|------------|
| Short-circuit protection               | Continuous |
| Input voltage, MGJ6-FB 5V input types  | 12V        |
| Input voltage, MGJ6-FB 12V input types | 20V        |
| Input voltage, MGJ6-FB 24V input types | 40V        |

### TECHNICAL NOTES

#### ISOLATION VOLTAGE

'Hi Pot Test', 'Flash Tested', 'Withstand Voltage', 'Proof Voltage', 'Dielectric Withstand Voltage' & 'Isolation Test Voltage' are all terms that relate to the same thing, a test voltage, applied for a specified time, across a component designed to provide electrical isolation, to verify the integrity of that isolation.

Murata Power Solutions MGJ6-FB series of DC-DC converters are all 100% production tested at 4kVACrms for 1 second from input to output and 2.5kVACrms for 1 second from output to output. Also they are all qualification tested at 5.7kVDC for 1 minute from input to output and 3kVDC for 1 minute from output to output.

The MGJ6-FB series is recognised by Underwriters Laboratory, please see safety approval section for more information. When the insulation in the MGJ6-FB series is not used as a safety barrier, i.e. provides functional isolation only, continuous or switched voltages across the barrier up to 3kV are sustainable. This is established by measuring the partial discharge Inception voltage in accordance with IEC 60270. Please contact Murata for further information.

#### REPEATED HIGH-VOLTAGE ISOLATION TESTING

It is well known that repeated high-voltage isolation testing of a barrier component can actually degrade isolation capability, to a lesser or greater degree depending on materials, construction and environment. We therefore strongly advise against repeated high voltage isolation testing, but if it is absolutely required, that the voltage be reduced by 20% from specified test voltage.

### SAFETY APPROVAL

#### ANSI/AAMI ES60601-1

The MGJ6-FB series is recognised by Underwriters Laboratory (UL) to ANSI/AAMI ES60601-1 and provides 2 MOPP (Means Of Patient Protection) based on a working voltage of 250vrms.

#### UL60950

The MGJ6-FB series is recognised by Underwriters Laboratory (UL) to UL60950 for reinforced insulation to a working voltage of 250Vrms with a maximum measured product operating temperature of 130°C.

Creepage and clearance 8mm, input to output & across outputs.

Working altitude 5000m

Over voltage category (OVC) II

#### FUSING

The MGJ6-FB Series of converters are not internally fused so to meet the requirements of UL an anti-surge input line fuse should always be used with ratings as defined below.

Input Voltage, 5V 4A

Input Voltage, 12V 2A

Input Voltage, 24V 1A

All fuses should be UL recognised, 250Vac rated.

### RoHS COMPLIANCE, MSL, PSL AND REFLOW SOLDERING INFORMATION



This series is compatible with Pb-Free soldering systems and is also backward compatible with Sn/Pb soldering systems. The MGJ6 full bridge series has a process, moisture, and reflow sensitivity classification of MSL2 PSL R7F as defined in J-STD-020 and J-STD-075. Please refer to [application notes](#) for further information. This translates to: MSL2 = 1 year floor life, PSL R7F = Peak reflow temperature 245°C with a limitation on the time above liquidus (217°C) which for this series is 90sec max. The pin termination finish on this product series is Gold with Nickel Pre-plate.

### ENVIRONMENTAL VALIDATION TESTING

The following tests have been conducted on this product series, please contact Murata if further information about the tests is required.

| Test                               | Standard   | Condition   |
|------------------------------------|--|---|
| Temperature cycling                | MIL-STD-883 Method 1010, Condition B                                     | 10 cycles between two chambers set to achieve -55°C and +125°C. The dwell time shall not be less than 10min and the load shall reach the specified temperature in 15min.  |
| Humidity bias                      | JEDEC JESD22-A101  | 85±2°C, 85±5% R.H. for 1000 (+168/-24) hours.   |
| High Temperature Storage life      | JEDEC JESD22-A103, Condition A   | 125°C +10/-0°C for ≥1000 hours.   |
| Vibration                          | BS EN 61373 with respect to BS EN 60068-2-64, Test Fh Category 1 Class B | 5 – 150Hz. Level at each axis – Vertical, Traverse and Longitudinal: 5.72m/s <sup>2</sup> rms. 5 hours in each axis. Crest factor: 3 Sigma. Device is secured via surface mount pins.   |
| Solderability                      | EIA/IPC/JEDEC J-STD-002, Test S and S1                                   | The parts are conditioned in a steam ager for 8 hours ±15 min. at a temperature of 93±3°C. SnPb (Test S): The parts are placed onto a stencil with Sn60Pb40 solder paste on and then placed into the reflow oven at 215 ±5°C for 50–70 seconds.<br>Pb-free (Test S1): The parts are placed onto a stencil with Sn96.5Ag3.0Cu0.5 solder paste on and then placed into the reflow oven at 245 ±5°C for 30–60 seconds. |
| Solvent cleaning                   | Resistance to cleaning agents.   | Solvent – Novec 71IPA & Topklean EL-20A. Pulsed ultrasonic immersion 45°C - 65°C  |
| Solvent Resistance                 | MIL-STD-883 Method 2015  | The parts and the bristle portion of the brush are immersed in Isopropanol for a minimum of 1 minute. The parts are brushed 3 times, after the third time the parts are blown dry and inspected.  |
| Moisture sensitivity level (MSL 2) | Based on IPC/JEDEC J-STD-020   | Bake samples at 125 +5/-0°C for 24hours minimum before conditioning in the temperature/humidity chamber for 168 hours at 85°C/60%RH and Pb Free JEDEC Max profile conditioning with electrical testing, co-planarity inspection before and after.   |

### PART NUMBER STRUCTURE

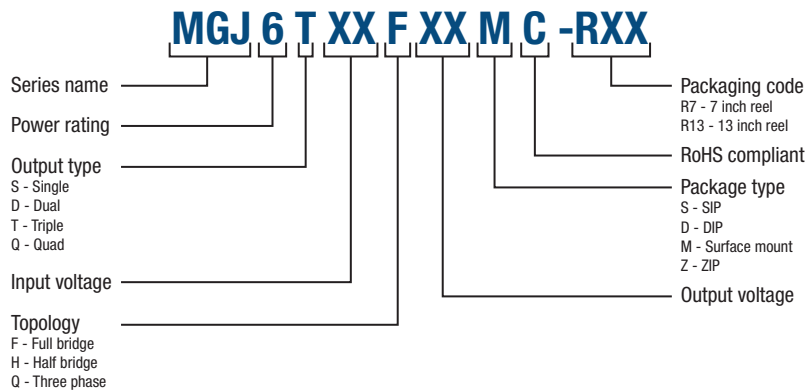

## CHARACTERISATION TEST METHODS

### Ripple & Noise Characterisation Method

Ripple and noise measurements are performed with the following test configuration.

|  |  |
|--|--|
| C1   | 1µF X7R multilayer ceramic capacitor, voltage rating to be a minimum of 3 times the output voltage of the DC-DC converter                                |
| C2   | 10µF tantalum capacitor, voltage rating to be a minimum of 1.5 times the output voltage of the DC-DC converter with an ESR of less than 100mΩ at 100 kHz |
| C3   | 100nF multilayer ceramic capacitor, general purpose  |
| R1   | 450Ω resistor, carbon film, ±1% tolerance  |
| R2   | 50Ω BNC termination  |
| T1   | 3T of the coax cable through a ferrite toroid  |
| RLOAD  | Resistive load to the maximum power rating of the DC-DC converter. Connections should be made via twisted wires  |
| Measured values are multiplied by 10 to obtain the specified values. |  |

Differential Mode Noise Test Schematic

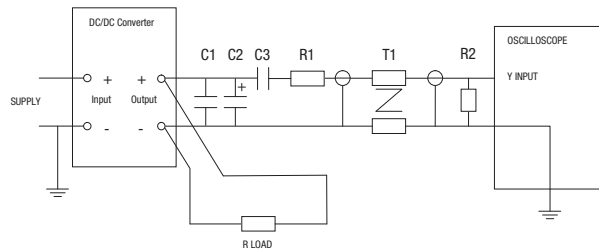

### APPLICATION NOTES

#### Disable/Frequency synchronisation

Please refer to application notes for further information.

|                           |                   | Min  | Typ | Max | Units |
|---------------------------|-------------------|------|-----|-----|-------|
| Disable/Sync <sup>1</sup> | Pull Down Current |      | 0.5 |     | mA    |
|                           | Input High        | 2    |     | 60  | V     |
|                           | Input Low         | -0.6 |     | 0.8 | V     |
| Synchronisation           | Frequency Range   | 90   | 100 | 110 | kHz   |
|                           | Duty Cycle        | 25   |     | 75  | %     |

The Disable/Synchronization pin has three modes:

1. When a DC logic low voltage is applied to this pin the MGJ6-FB is disabled and enters a low quiescent current sleep mode.
2. When this pin is left floating or a DC logic high (CMOS/TTL compatible) voltage is applied the MGJ6-FB is enabled and operates at the programmed frequency of 100kHz.
3. When a square wave of between 90kHz and 110kHz is applied to this pin, the switcher operates at the same frequency as the square wave. The falling edge of the square wave corresponds to the start of the switching cycle. If the signal is slower than 25Hz, it will be interpreted as enabling and disabling the part. If the MGJ6-FB is disabled, it must be disabled for 7 clock cycles before being re-enabled.

Note: The  $\overline{\text{Dis}}/\text{Sync}$  pin is a high impedance TTL input and can be triggered by noise from external circuits if not treated carefully.

Please refer to "LAYOUT CONSIDERATIONS" and "SYNCHRONISATION CIRCUIT" for further details.

[Click here for general guidance for gate drive applications.](#)

#### LAYOUT CONSIDERATIONS

Unlike standard isolated DC-DC products the MGJ6-FB series has been designed specifically for high side gate drive applications where the outputs are being driven to a high voltage at a very high dV/dT. This is possible due to minimum transformer isolation capacitance and considered circuit design regarding common mode transient immunity. It is important that these few simple pcb layout guidelines are implemented so as not to compromise the performance of the DC-DC and that of the overall system.

1. The keep clear area shown must not have any copper traces even on internal layers. This is not only to avoid compromising the creepage and clearance distance but also to minimise capacitive isolation between the noisy output circuits and input control circuits. In general it is good practice to maintain the same band of clearance area running directly through both the DC-DC and the gate drive isolators as shown so that input and output are kept separate and do not overlap or mesh together at any point.
2. A top layer ground plane copper area connected to  $-\text{Vin}$  can be used to create an effective screen to the underside of the MGJ6-FB series and can also be used as a guard ring for the gate drive isolator inputs. If the  $\overline{\text{Dis}}/\text{Sync}$  pin is being used then it is imperative that it follows a route covered by this screen to avoid differential pick up. It should also be kept as short as possible.

Please refer to "PACKAGE SPECIFICATIONS" for recommended layout.

#### SYNCHRONISATION CIRCUIT

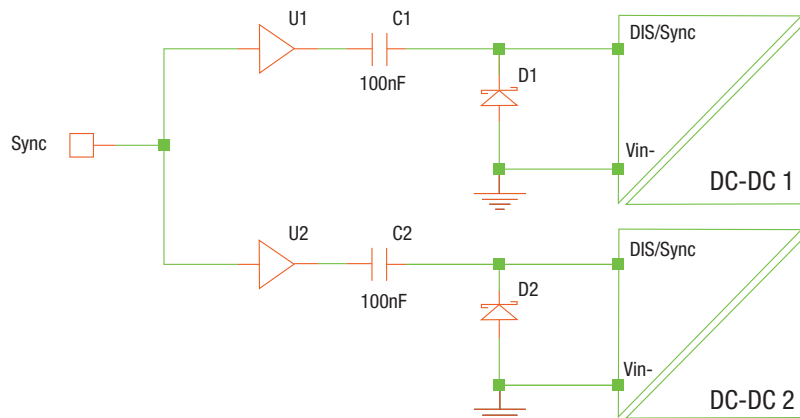

1. A suggested synchronisation circuit is shown. C1 and C2 are 100nF capacitors. D1 and D2 are schottky diodes. The capacitive isolation and close connected diode ensures that a transition from high to low is seen at the input pin even in a noisy environment or when there is a slight ground shift between devices.
2. If the  $\overline{\text{Dis}}/\text{Sync}$  pin is not used for synchronisation, then a 22nF capacitor can be added between the  $\overline{\text{Dis}}/\text{Sync}$  pin and  $-\text{Vin}$  pin to improve noise immunity. If the functionality of  $\overline{\text{Dis}}/\text{Sync}$  is not required, the  $\overline{\text{Dis}}/\text{Sync}$  pin can be connected directly to the  $+\text{Vin}$  pin to improve noise immunity.
3. One very effective method to reduce common mode transient interference is to add a common mode filter to the DC input. It may only be necessary to add one before splitting the supply to each DC-DC.

## APPLICATION NOTES (Continued)

### Start-up times

Typical start up times for this series, with recommended maximum additional output capacitance are:

| Part No.            | Start-up times |
|---------------------|----------------|
|                     | ms             |
| <b>MGJ6T05F24MC</b> | 30             |
| <b>MGJ6T12F24MC</b> | 30             |
| <b>MGJ6T24F24MC</b> | 30             |

Output capacitance must not exceed:

| Output Voltage | Maximum output capacitance |
|----------------|----------------------------|
| V              | μF                         |
| 24 VHA         | 27                         |
| 24 VHB         | 27                         |
| 24 VL          | 56                         |

### Output configurations for power switches

There are several zener based divider circuits that can be used to configure a bipolar output for gate drives as shown below. The table below shows suggested component values for various power switches using circuit A.

| Component                | IGBT | SIC | MOSFET |
|--------------------------|------|-----|--------|
| Zener diode <sup>1</sup> | 9V1  | 5V1 | 9V1    |
| Resistor                 | 15K  | 18K | 15K    |

1. Suggested zener diode is BZX84C.

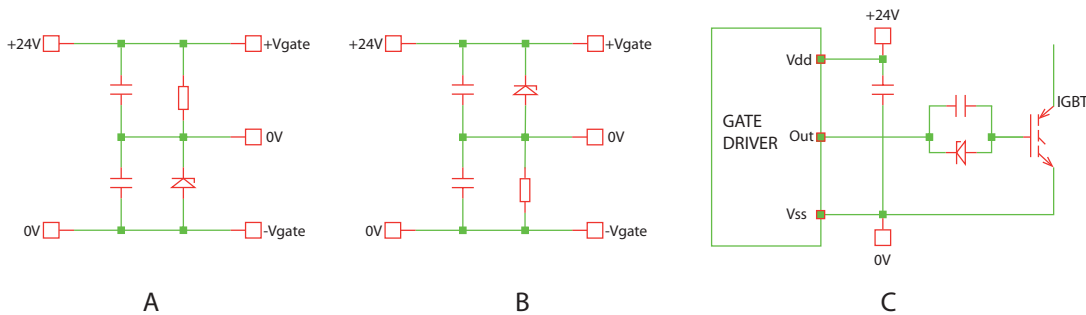

**APPLICATION NOTES (Continued)**

**Schematic for driving IGBT**

The following circuit shows an example of a complete full bridge and how the DC-DC would be connected using the zener divider in circuit A (page 5).

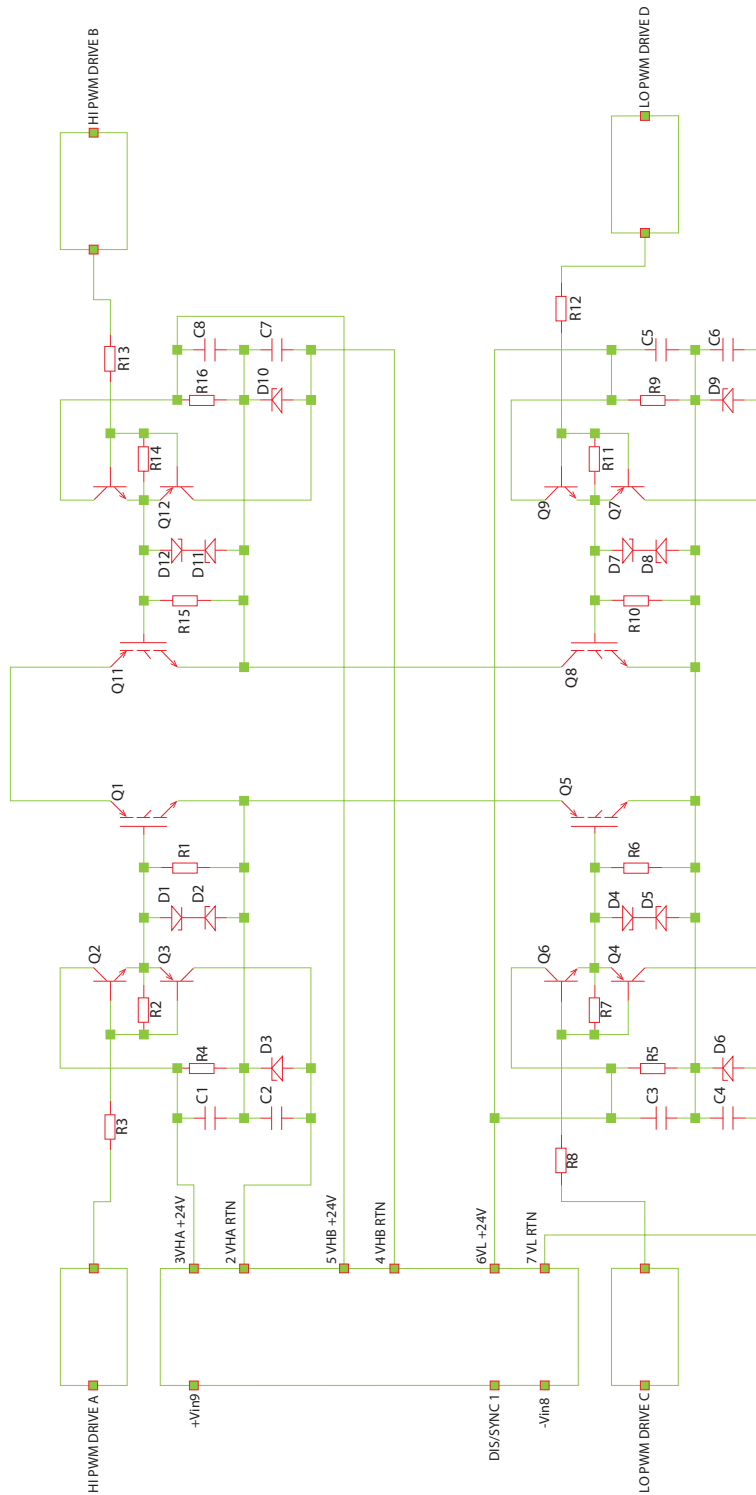



**APPLICATION NOTES (Continued)**

**Schematic for driving IGBT**

For some high frequency applications where each low side device has a kelvin sense terminal or it is necessary to connect the gate drive supply as close to the device terminal as possible the following circuit can be used. By adding 10 Ohm resistors in the positive and negative gate supply lines to each gate drive circuit it is possible to create a high frequency separation between the supplies. This means it is possible to significantly reduce the emitter inductance in the gate driving loop without the need for separate isolated supplies

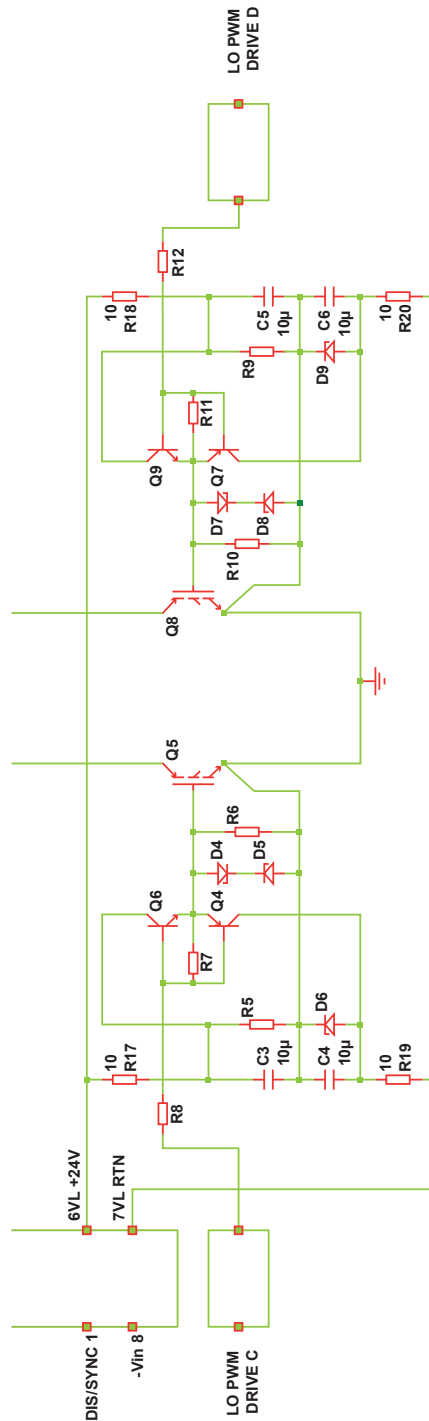

**APPLICATION NOTES (Continued)**

**Schematic for Powering Three Phase Drivers on Electrical Vehicle Systems**

For three phase drives on an Electric Vehicle system it is sometimes necessary, for safety and diagnostic reasons to power the high side switches independently to the Low side switches. This means that if a fault occurs on a the high side switch it is possible to disable all of the high side switches without disabling the low side switches. The circuit below shows how two Full bridge MGJ6 units can be connected to achieve this.

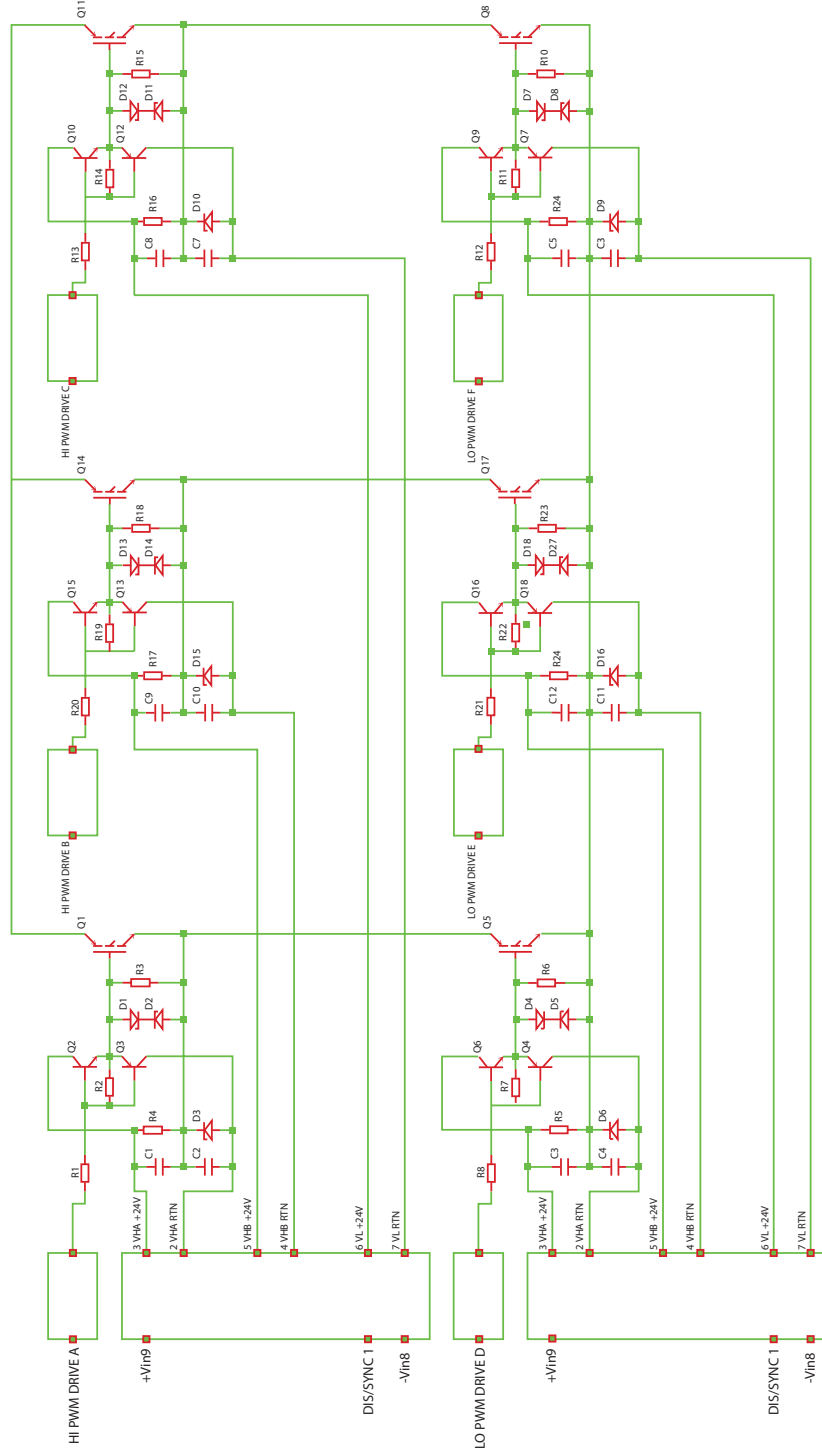

### APPLICATION NOTES (Continued)

For convenience the three isolated 24V outputs have been labelled VHA (Voltage A for high side), VHB (Voltage B for high side), and VL (Voltage for low side) however they can be swapped if this helps to improve system layout. It is recommended however that if VHA or VHB are used in place of VL that an additional 4.7uF ceramic capacitor is added close to the output pins to reduce ripple voltage.

Any output can be connected in parallel with another and all three outputs can also be connected in series with one another. With the possibility of series and parallel output connections a number of output configurations are possible. Some are shown below:

- A) 24V @ 0.25A
- B) 72V @ 0.083A output
- C) 72V @ 0.028A, 48V @ 0.042A and 24V @ 0.083A
- D) +48V/-24V @ 0.083A
- E) Non-isolated +24V to +96V boost converter @0.083A
- F) Non-isolated +12V to +84V boost converter @0.083A

**Note:** Any single 24V output can deliver up to 3W however the output power from all outputs combined must not exceed 6W

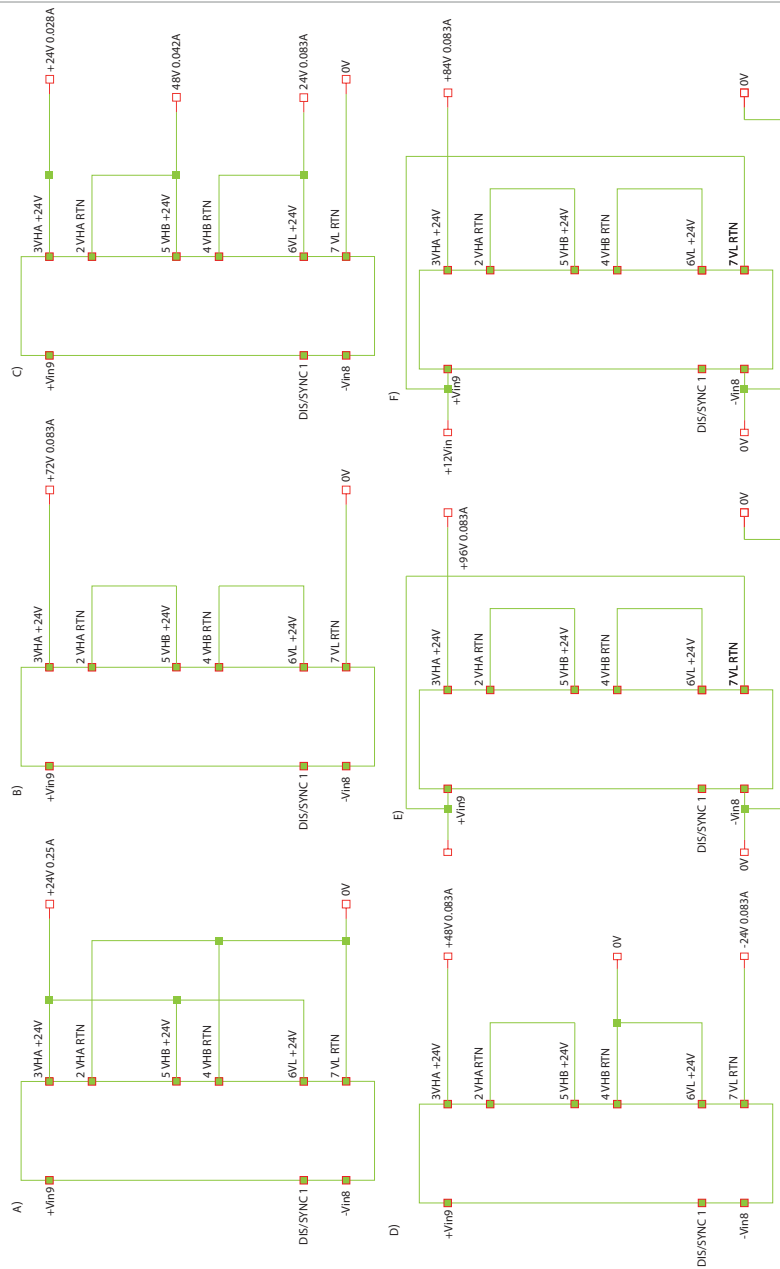

**APPLICATION NOTES (Continued)**

**SLIC Circuits**

The output configuration shown below could be used for subscriber line interface circuits (SLIC's), particularly for the Integrated Services Digital Network (ISDN) and also for standard telecommunications circuits where a local power source is preferred to the telephone system power due to either the power quality of the telecommunications system power supply or to avoid potential power line disturbances, such as lightning strikes and access switching, which will affect the target circuit function. Another application area is in fibre-in-the-loop (FITL) or radio-in-the-loop (RITL) interfacing via a standard telecommunication SLIC, where the usual telecommunication battery voltage is not available due to the transmission media in use (fibre or radio). In particular, FITL/RITL interfaces directly on PC cards, in local monitor and boost circuits and at exchanges between the fibre/radio and wire media. The supply rails can be used for ringing generators as well as SLIC circuits or where both are combined, such as in the AMD AM79R79 Ringing SLIC device (see figure 2). The -72V rail is used primarily for the generation of the ringing signal (VBAT1), the -48V rail is used to supply in line access circuitry (VBAT2) and the -24V supply for the on-chip regulator for the logic interface (VNEG). Alternative devices from other manufacturers could use the -24V output for their internal circuit supply and -72V for ringing.

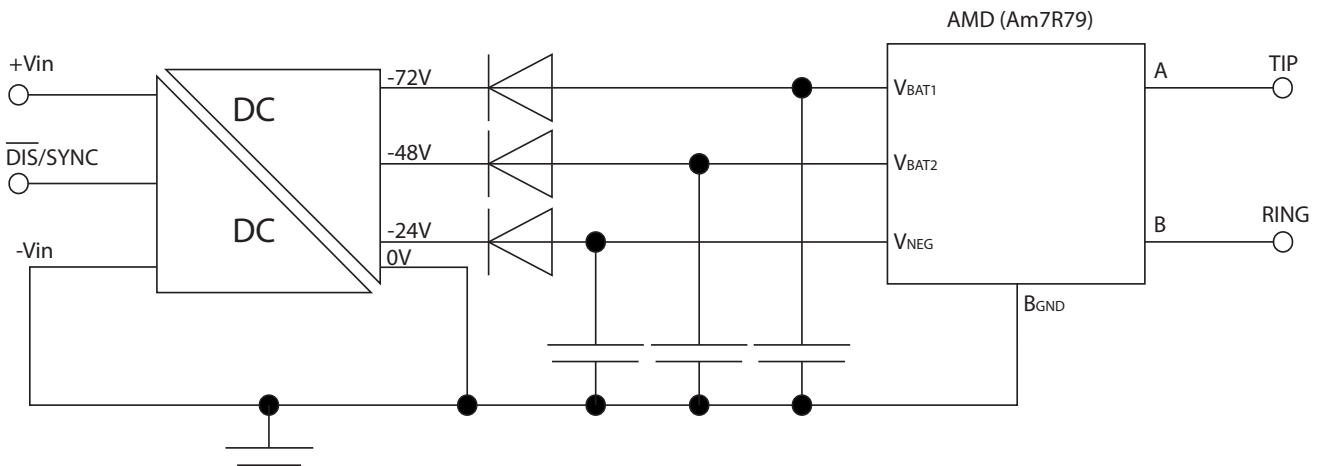

## EFFICIENCY VS LOAD

**MGJ6T05F24MC**

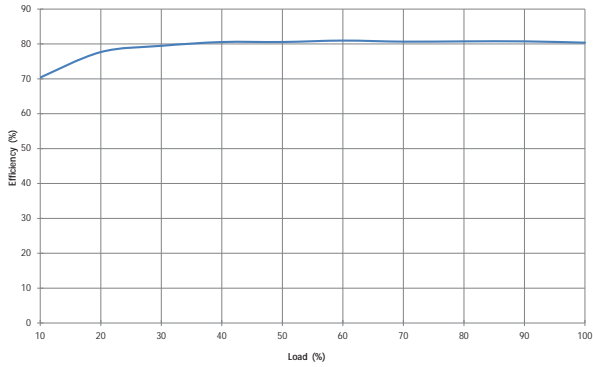

**MGJ6T12F24MC**

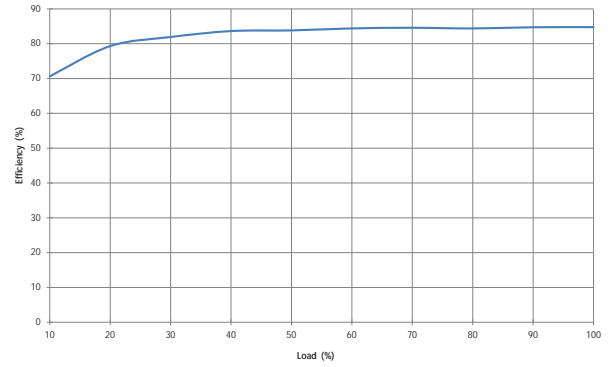

**MGJ6T24F24MC**

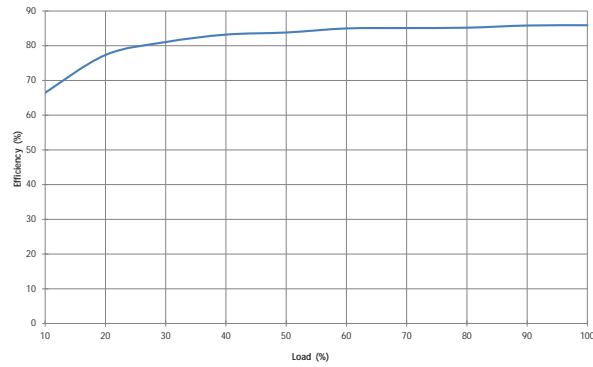

### TEMPERATURE DERATING

Derating curves are based on IPC-9592. With no derating some components may be operating at the manufacturers maximum temperature ratings.

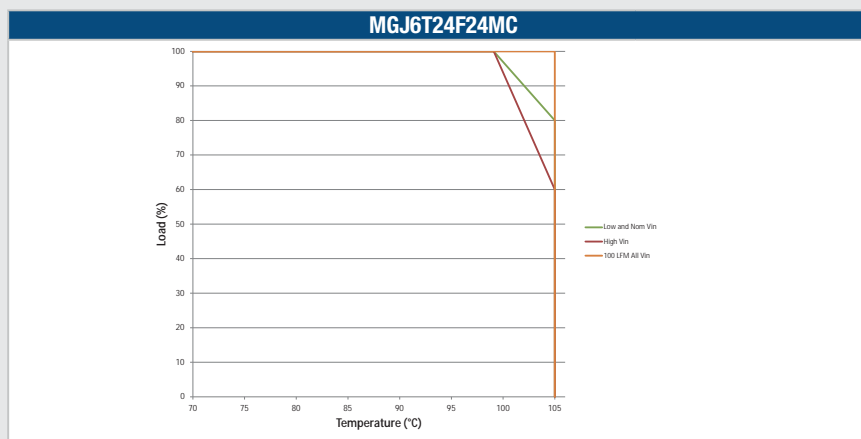
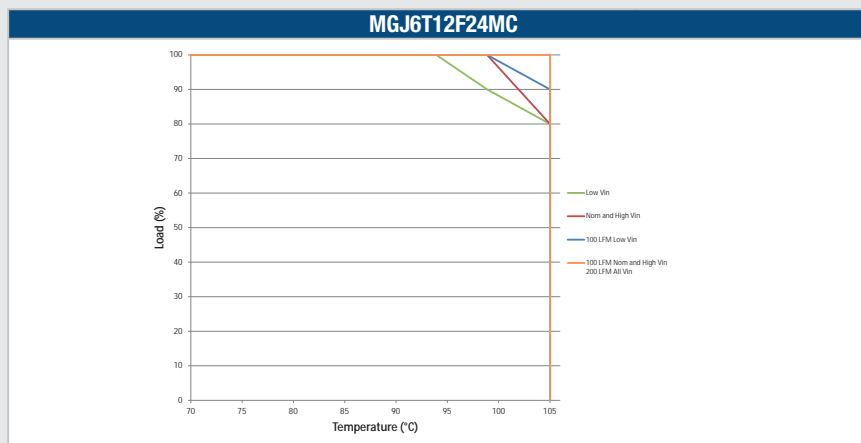
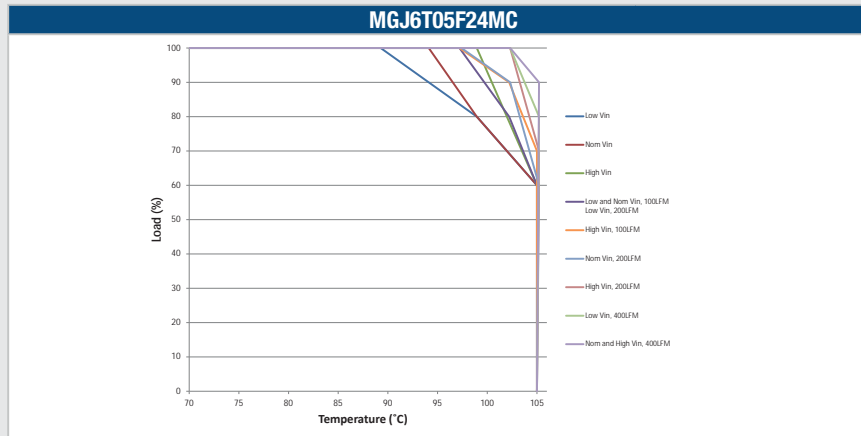

## EMC FILTERING AND SPECTRA

### FILTERING

The following filter circuit and filter table shows the input filters typically required to meet conducted emissions limits for EN 55022 curve B using Quasi-Peak (pink line) and average (green line) detectors according to CISPR22. The following plots show measurements of the positive (L1) and negative (L2) inputs for both Quasi-peak limit B adherence and Average limit B adherence. If a high dv/dt above 80kV/us is expected from output to input it is advised that a common mode filter is used on each output as this will reduce the common mode current circulating between outputs and input and causing interference.

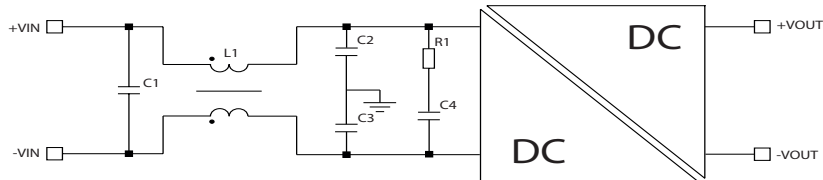

**C1, C2 & C3** Polyester or ceramic capacitor

**C4** Electrolytic capacitor (note R1 could be omitted if C4 has ESR  $\geq$  R1)

#### TO MEET CURVE B

| Part Number  | C1         | L1  | Part Number | C2  | C3  | R1         | C4          |
|--------------|------------|-----|-------------|-----|-----|------------|-------------|
| MGJ6T05F24MC | 10 $\mu$ F | 1mH | 51105C      | 1nF | 1nF | 1 $\Omega$ | 470 $\mu$ F |
| MGJ6T12F24MC | 10 $\mu$ F | 1mH | 51105C      | 1nF | 1nF | 1 $\Omega$ | 470 $\mu$ F |
| MGJ6T24F24MC | 10 $\mu$ F | 1mH | 51105C      | 1nF | 1nF | 1 $\Omega$ | 470 $\mu$ F |

MGJ6T05F24MC (Quasi Peak)

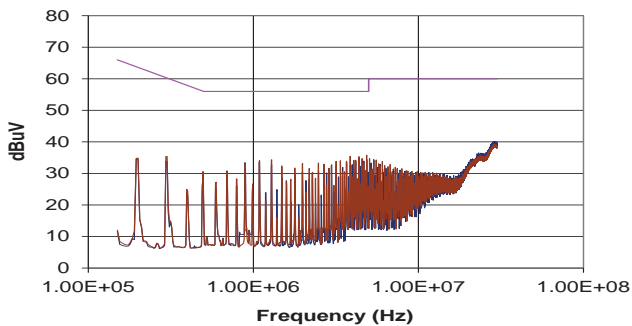

MGJ6T05F24MC (Average)

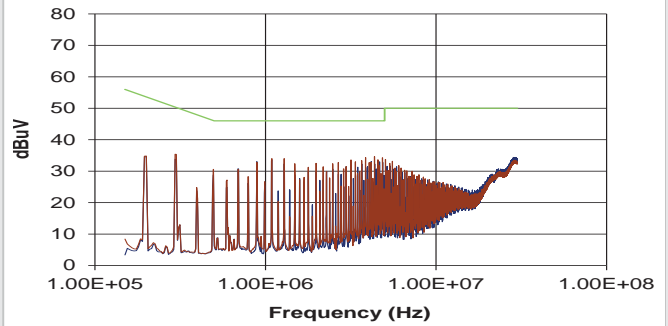

MGJ6T12F24MC (Quasi Peak)

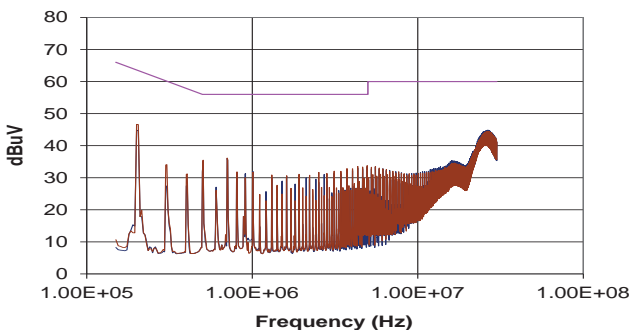

MGJ6T12F24MC (Average)

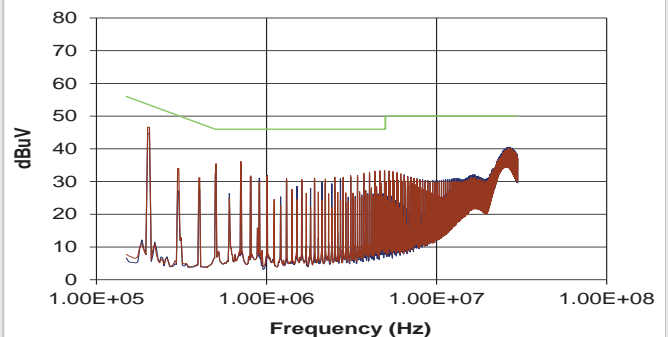

EMC FILTERING AND SPECTRA (Continued)

MGJ6T24F24MC (Quasi Peak)

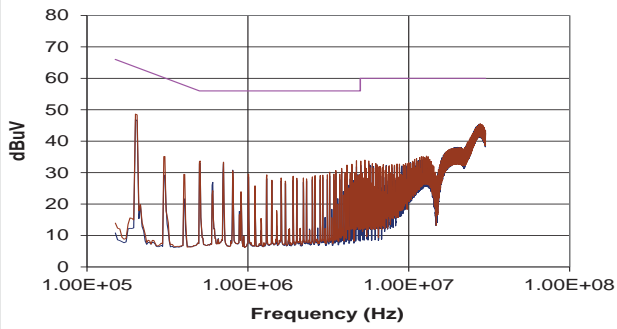

MGJ6T24F24MC (Average)

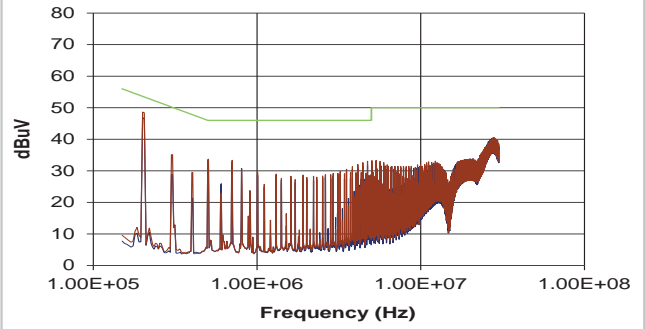



### PACKAGE SPECIFICATIONS

#### MECHANICAL DIMENSIONS

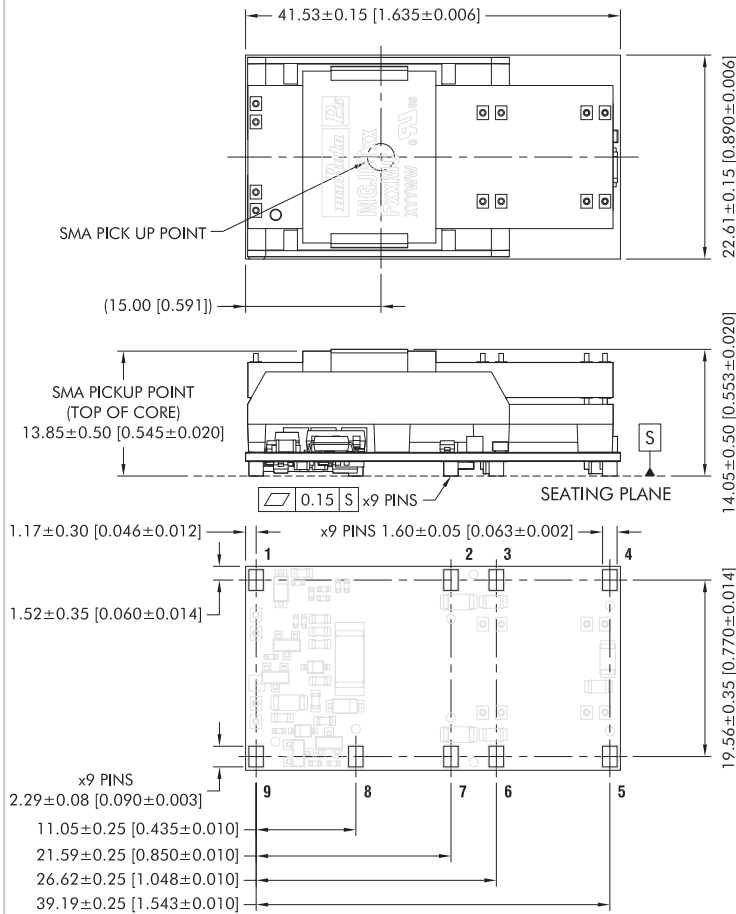

All dimensions in mm (inches). Controlling dimensions in mm.  
Component shown for reference only.

Weight: 17.3g

#### PIN CONNECTIONS

| Pin | Function |
|-----|----------|
| 1   | Dis/Sync |
| 2   | VHA RTN  |
| 3   | VHA +24V |
| 4   | VHB RTN  |
| 5   | VHB +24V |
| 6   | VL +24V  |
| 7   | VL RTN   |
| 8   | -Vin     |
| 9   | +Vin     |

#### RECOMMENDED FOOTPRINT DETAILS

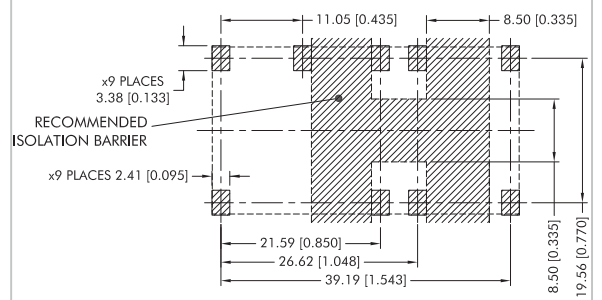

#### RECOMMENDED LAYOUT

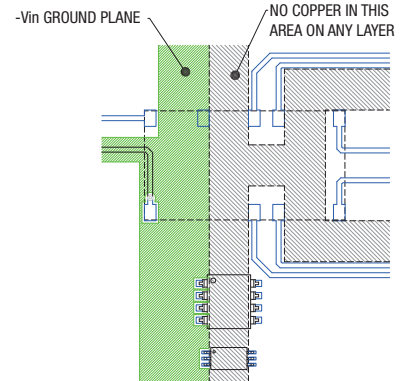

Please refer to "[LAYOUT CONSIDERATIONS](#)" for further details.

### TAPE & REEL SPECIFICATIONS

#### REEL OUTLINE DIMENSIONS

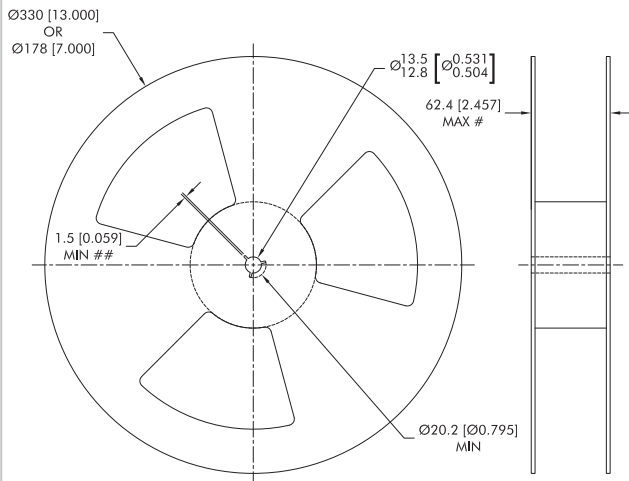

Tape & Reel specifications shall conform with current EIA-481 standard  
 Unless otherwise stated all dimensions in mm (inches)  
 Controlling dimension is mm  
 # Measured at hub  
 ## Six equi-spaced slots on 180mm/7" reel

#### REEL PACKAGING DETAILS

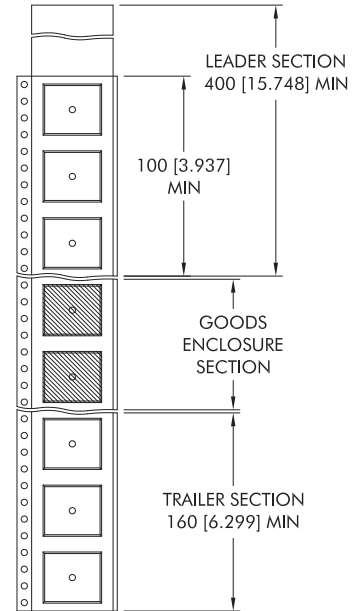

Reel Quantity: 7" - 23 or 13" - 92  
 Carrier tape pockets shown are illustrative only - refer to carrier tape diagram for actual pocket details

#### TAPE OUTLINE DIMENSIONS

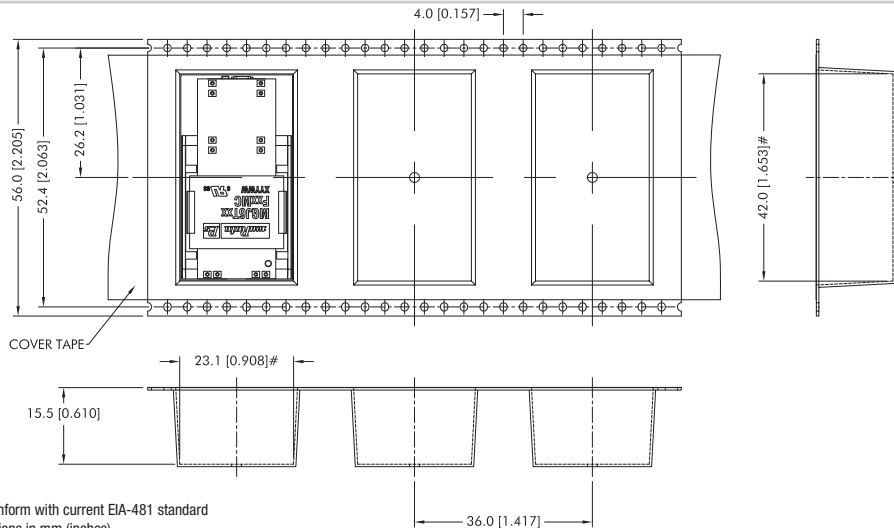

Tape & Reel specifications shall conform with current EIA-481 standard  
 Unless otherwise stated all dimensions in mm (inches)  
 Controlling dimension is mm  
 Components shall be orientated within the carrier tape as indicated  
 # Measured on a plane 0.3mm above the bottom pocket

### DISCLAIMER

Unless otherwise stated in the datasheet, all products are designed for standard commercial and industrial applications and NOT for safety-critical and/or life-critical applications.

Particularly for safety-critical and/or life-critical applications, i.e. applications that may directly endanger or cause the loss of life, inflict bodily harm and/or loss or severe damage to equipment/property, and severely harm the environment, a prior explicit written approval from Murata is strictly required. Any use of Murata standard products for any safety-critical, life-critical or any related applications without any prior explicit written approval from Murata shall be deemed unauthorised use.

These applications include but are not limited to:

- Aircraft equipment
- Aerospace equipment
- Undersea equipment
- Power plant control equipment
- Medical equipment
- Transportation equipment ( automobiles, trains, ships, etc.)
- Traffic signal equipment
- Disaster prevention / crime prevention equipment
- Data Processing equipment

Murata makes no express or implied warranty, representation, or guarantee of suitability, fitness for any particular use/purpose and/or compatibility with any application or device of the buyer, nor does Murata assume any liability whatsoever arising out of unauthorised use of any Murata product for the application of the buyer. The suitability, fitness for any particular use/purpose and/or compatibility of Murata product with any application or device of the buyer remain to be the responsibility and liability of the buyer.

Buyer represents and agrees that it has all the necessary expertise to create and implement safeguards that anticipate dangerous consequences of failures, monitor failures and their consequences, lessen the likelihood of failures that might cause harm, and take appropriate remedial actions. Buyer will fully indemnify and hold Murata, its affiliated companies, and its representatives harmless against any damages arising out of unauthorised use of any Murata products in any safety-critical and/or life-critical applications.

Remark: Murata in this section refers to Murata Manufacturing Company and its affiliated companies worldwide including, but not limited to, Murata Power Solutions.



**This product is subject to the following [operating requirements](https://www.murata.com/en-eu/products/power/requirements) and the [Life and Safety Critical Application Sales Policy](https://www.murata.com/en-eu/products/power/requirements):**

**Refer to:** <https://www.murata.com/en-eu/products/power/requirements>

Murata Power Solutions (Milton Keynes) Ltd. makes no representation that the use of its products in the circuits described herein, or the use of other technical information contained herein, will not infringe upon existing or future patent rights. The descriptions contained herein do not imply the granting of licenses to make, use, or sell equipment constructed in accordance therewith. Specifications are subject to change without notice.

© 2021 Murata Power Solutions (Milton Keynes) Ltd.