

REVISIONS					
REV	ECO	DESCRIPTION	DATE	BY	APPR
A1	-	FIRST RELEASE	May,15,2015	Drack	TOMMY

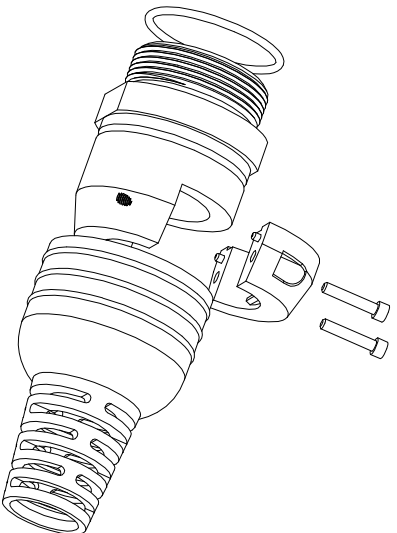
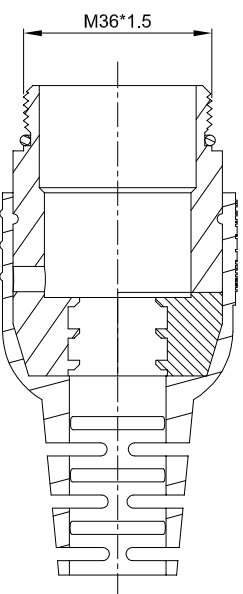
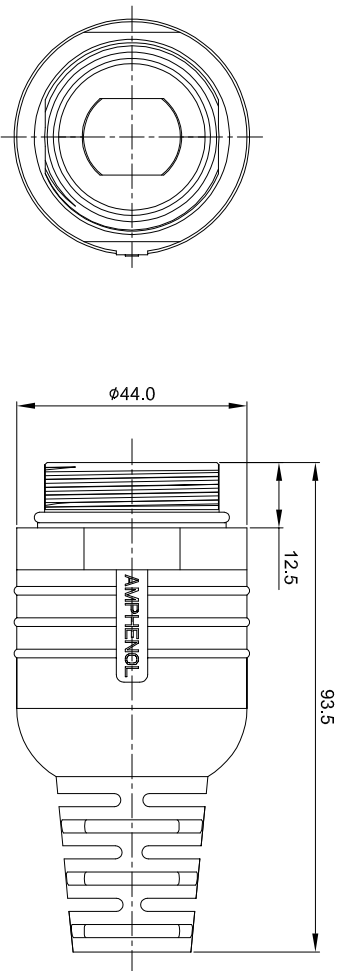

NOTES: UNLESS OTHERWISE SPECIFIED

1. MATERIAL:
BOOT: THERMOPLASTIC ELASTOMER
SEAL: VITON
HOUSING BODY: ZINC DIE CAST, NICKEL PLATED

2. SPECIFICATIONS:
2.1 DEGREE OF PROTECTION: IP67 (MATED CONDITION)
2.2 RoHS COMPLIANT
2.3 CABLE OD RANGE:17.5-18.5mm

3. ALL DIMENSIONS ARE FOR REFERENCE USE ONLY.

QUANTITY	SEE PART NUMBER CHART	PART NUMBER	DESCRIPTION	ITEM
MATERIALS LIST				
UNLESS OTHERWISE SPECIFIED				
1) All dimensions are in millimeters.				
2) Tolerances are as follows:				
1 Pt. DEC 20.30 Fractions ±1/64				
3 Pt. DEC 20.48 Angles ±1°				
3) Note reference = APPROVAL:				
MATERIAL SPECIFICATIONS:				
CUSTOMER:				
PROCESS SPECIFICATIONS:				
NEXT ASSY:				
THIS DRAWING IS SUPPLIED FOR YOUR INFORMATION ONLY. IT IS NOT TO BE USED FOR REPRODUCTION OR REPRODUCTION AND PERFORMANCE DATA SHOWN HEREON ARE THE PROPERTY OF AMPHENOL. ALL RIGHTS OF REPRODUCTION ARE RESERVED. DIMENSIONS ARE SUBJECT TO NORMAL MANUFACTURING VARIATIONS.				
SCALE:	B	TYPE:	C-	DWG NO.:
SCALE:	NONE	TYPE:	C-	DWG NO.:
SHEET:	1	OF:	1	REVISION:
SHEET:	1	OF:	1	REVISION:

Amphenol

Shie Systems - www.amphenol-shie.com
44724 Modely Drive
Clifton Township, MI 48036

M40.CORD GRIP 17.5-18.5mm