

# CGH27060F

60 W Peak, 28 V, GaN HEMT for Linear Communications from VHF to 3 GHz

## Description

Cree's CGH27060F is a gallium nitride (GaN) high electron mobility transistor (HEMT) designed specifically for high efficiency, high gain and wide bandwidth capabilities, which makes the CGH27060F ideal for VHF, Comms, 3G, 4G, LTE, 2.3-2.9GHz WiMAX and BWA amplifier applications. The unmatched transistor is supplied in a ceramic/metal flange package.



Package Type: 440193  
PN: CGH27060F

## Typical Performance Over 2.3-2.7 GHz ( $T_c = 25^\circ\text{C}$ ) of Demonstration Amplifier

Parameter	2.3 GHz	2.4 GHz	2.5 GHz	2.6 GHz	2.7 GHz	Units
Small Signal Gain	15.1	14.7	14.3	14.3	14.5	dB
EVM @ 39 dBm	2.35	2.16	2.01	2.13	2.82	%
Drain Efficiency @ 39 dBm	28.3	27.6	27.3	26.7	26.3	%
Input Return Loss	10.0	7.3	6.0	7.0	10.3	dB

Note: Measured in the CGH27060F-AMP amplifier circuit, under 802.16 OFDM, 3.5 MHz Channel BW, 1/4 Cyclic Prefix, 64 QAM Modulated Burst, 5 ms Burst, Symbol Length of 59, Coding Type RS-CC, Coding Rate Type 2/3, PAR = 9.8 dB @ 0.01 % Probability on CCDF

## Features

- VHF - 3.0 GHz Operation
- 14 dB Small Signal Gain
- 8.0 W  $P_{AVE}$  at < 2.0% EVM
- 27% Drain Efficiency at 8 W Average Power
- WiMAX Fixed Access 802.16-2004 OFDM
- WiMAX Mobile Access 802.16e OFDMA

 Large Signal Models Available for ADS and MWO

**RoHS**  
COMPLIANT



## Absolute Maximum Ratings (not simultaneous) at 25 °C Case Temperature

Parameter	Symbol	Rating	Units	Conditions
Drain-Source Voltage	$V_{DS}$	120	Volts	25 °C
Gate-to-Source Voltage	$V_{GS}$	-10, +2	Volts	25 °C
Storage Temperature	$T_{STG}$	-65, +150	°C	
Operating Junction Temperature	$T_J$	225	°C	
Maximum Forward Gate Current	$I_{GMAX}$	15	mA	25 °C
Maximum Drain Current <sup>1</sup>	$I_{DMAX}$	6	A	25 °C
Soldering Temperature <sup>2</sup>	$T_S$	245	°C	
Screw Torque	$\tau$	40	in-oz	
Thermal Resistance, Junction to Case <sup>3</sup>	$R_{\theta JC}$	2.8	°C/W	85 °C
Case Operating Temperature <sup>3</sup>	$T_C$	-40, +150	°C	

Notes:

<sup>1</sup> Current limit for long term, reliable operation

<sup>2</sup> Refer to the Application Note on soldering at [wolfspeed.com/RF/Document-Library](http://wolfspeed.com/RF/Document-Library)

<sup>3</sup> Measured for the CGH27060F at  $P_{DISS} = 56$  W

## Electrical Characteristics ( $T_C = 25$ °C)

Characteristics	Symbol	Min.	Typ.	Max.	Units	Conditions
<b>DC Characteristics<sup>1</sup></b>						
Gate Threshold Voltage	$V_{GS(th)}$	-3.5	-3.0	-2.0	VDC	$V_{DS} = 10$ V, $I_D = 14.4$ mA
Gate Quiescent Voltage	$V_{GS(Q)}$	-	-2.7	-	VDC	$V_{DS} = 28$ V, $I_{DQ} = 300$ mA
Saturated Drain Current	$I_{DS}$	11.6	14.0	-	A	$V_{DS} = 6.0$ V, $V_{GS} = 2$ V
Drain-Source Breakdown Voltage	$V_{BR}$	84	-	-	VDC	$V_{GS} = -8$ V, $I_D = 14.4$ mA
<b>RF Characteristics<sup>2,3</sup> (<math>T_C = 25</math> °C, <math>F_0 = 2.5</math> GHz unless otherwise noted)</b>						
Small Signal Gain	$G_{SS}$	11.0	13.0	-	dB	$V_{DD} = 28$ V, $I_{DQ} = 300$ mA
Drain Efficiency <sup>4</sup>	$\eta$	21	24	-	%	$V_{DD} = 28$ V, $I_{DQ} = 300$ mA, $P_{AVE} = 8$ W
Error Vector Magnitude	EVM	-	2.0	-		$V_{DD} = 28$ V, $I_{DQ} = 300$ mA, $P_{AVE} = 8$ W
Output Mismatch Stress	VSWR	-	-	10 : 1	Y	No damage at all phase angles, $V_{DD} = 28$ V, $I_{DQ} = 300$ mA, $P_{AVE} = 8$ W
<b>Dynamic Characteristics</b>						
Input Capacitance	$C_{GS}$	-	19.0	-	pF	$V_{DS} = 28$ V, $V_{GS} = -8$ V, $f = 1$ MHz
Output Capacitance	$C_{DS}$	-	5.9	-	pF	$V_{DS} = 28$ V, $V_{GS} = -8$ V, $f = 1$ MHz
Feedback Capacitance	$C_{GD}$	-	0.8	-	pF	$V_{DS} = 28$ V, $V_{GS} = -8$ V, $f = 1$ MHz

Notes:

<sup>1</sup> Measured on wafer prior to packaging

<sup>2</sup> Measured in the CGH27060F-AMP test fixture

<sup>3</sup> Under 802.16 OFDM, 3.5 MHz Channel BW, 1/4 Cyclic Prefix, 64 QAM Modulated Burst, 5 ms Burst, Symbol Length of 59, Coding Type RS-CC, Coding Rate Type 2/3, PAR = 9.8 dB @ 0.01 % Probability on CCDF

<sup>4</sup> Drain Efficiency =  $P_{OUT} / P_{DC}$

Typical WiMAX Performance

Figure 1. Gain and Return Loss vs Frequency measured in Broadband Amplifier Circuit CGH27060F-AMP,  $V_{DD} = 28\text{ V}$ ,  $I_{DQ} = 300\text{ mA}$

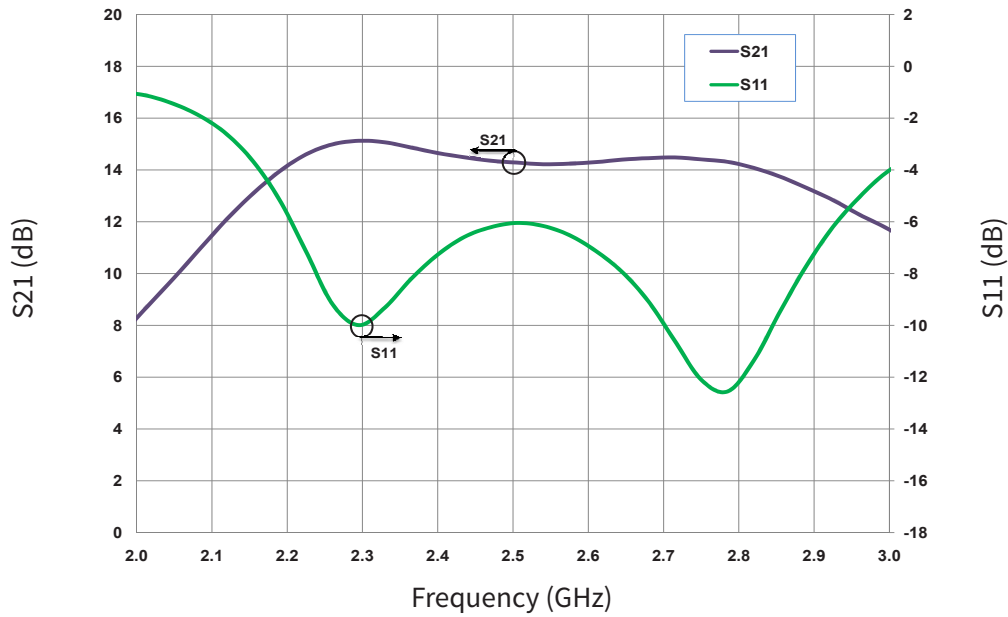
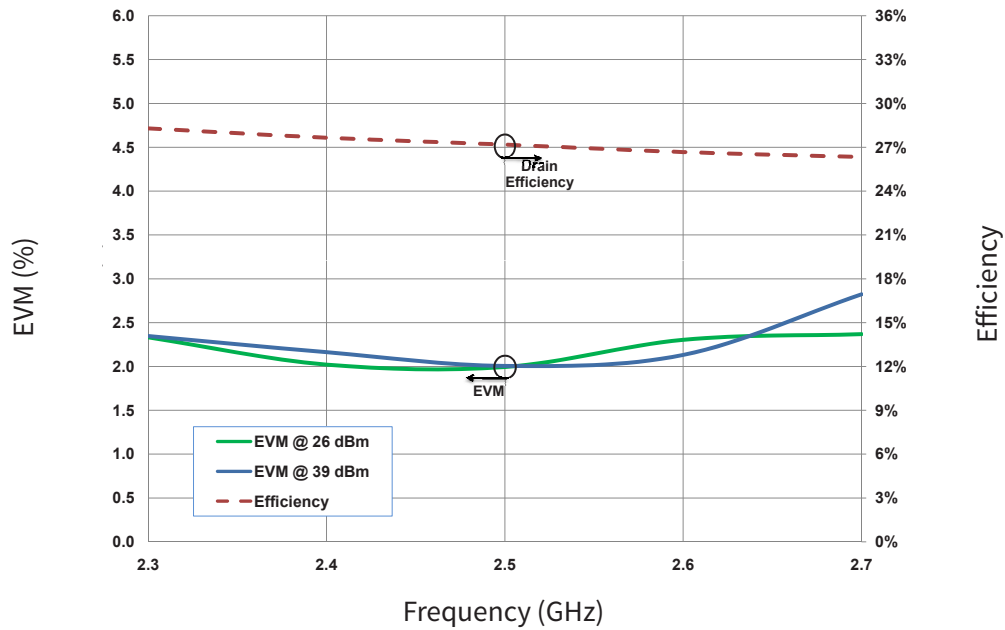

Figure 2. Typical EVM at 24 dBm and 39 dBm vs Frequency measured in Broadband Amplifier Circuit CGH27060F-AMP



Note: Under 802.16-2004 OFDM, 3.5 MHz Channel BW, 1/4 Cyclic Prefix, 64 QAM Modulated Burst, Symbol Length of 59, Coding Type RS-CC, Coding Rate Type 2/3.



Typical WiMAX Performance

**Figure 3. Drain Efficiency and EVM vs Output Power measured in CGH27060F-AMP**  
 $V_{DD} = 28\text{ V}$ ,  $I_{DQ} = 300\text{ mA}$ , 802.16-2004 OFDM, PAR = 9.8 dB

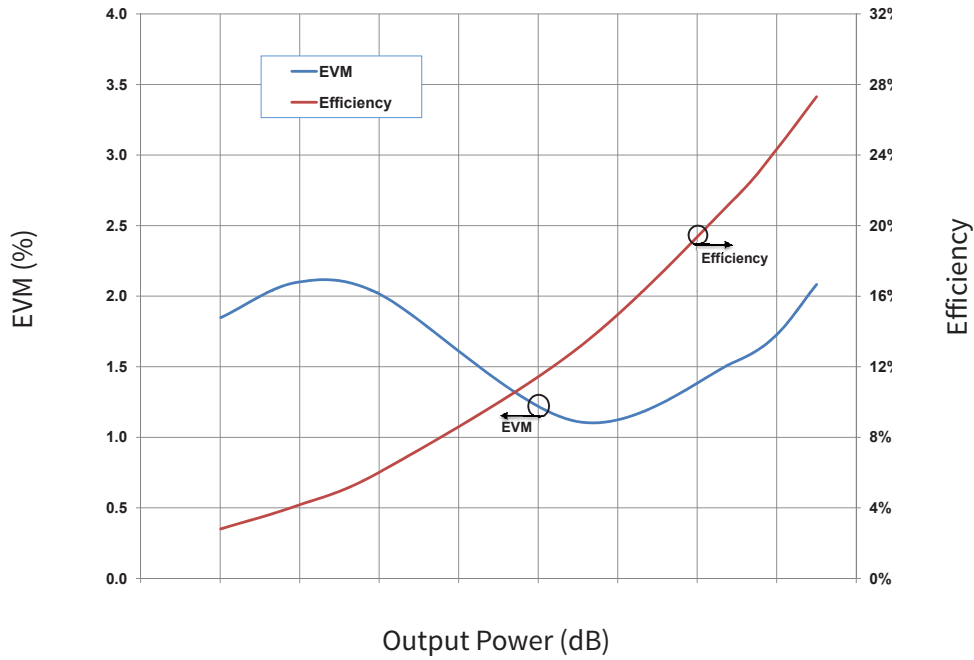

**Figure 4. Typical Gain and Efficiency versus Power Output measured in CGH27060F-AMP**  
 $V_{DD} = 28\text{ V}$ ,  $I_{DQ} = 300\text{ mA}$ , 802.16-2004 OFDM, PAR=9.8 dB

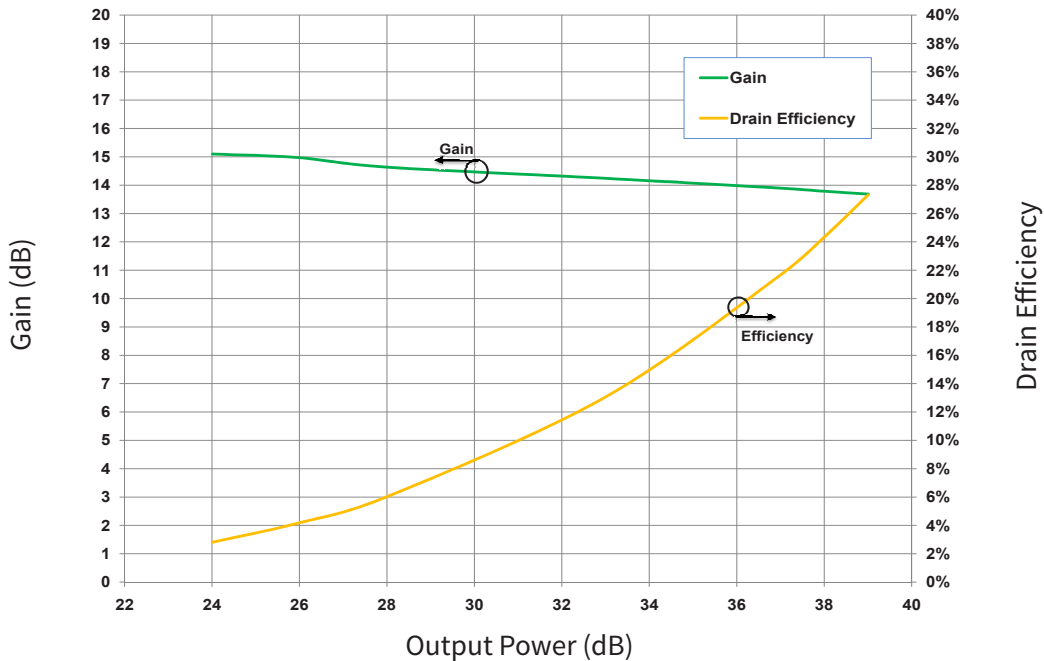

Note: Under 802.16-2004 OFDM, 3.5 MHz Channel BW, 1/4 Cyclic Prefix, 64 QAM Modulated Burst, Symbol Length of 59, Coding Type RS-CC, Coding Rate Type 2/3.



**Typical Performance**

**Figure 5. Simulated Maximum Available Gain and K Factor of the CGH27060F**

$V_{DD} = 28\text{ V}, I_{DQ} = 300\text{ mA}$

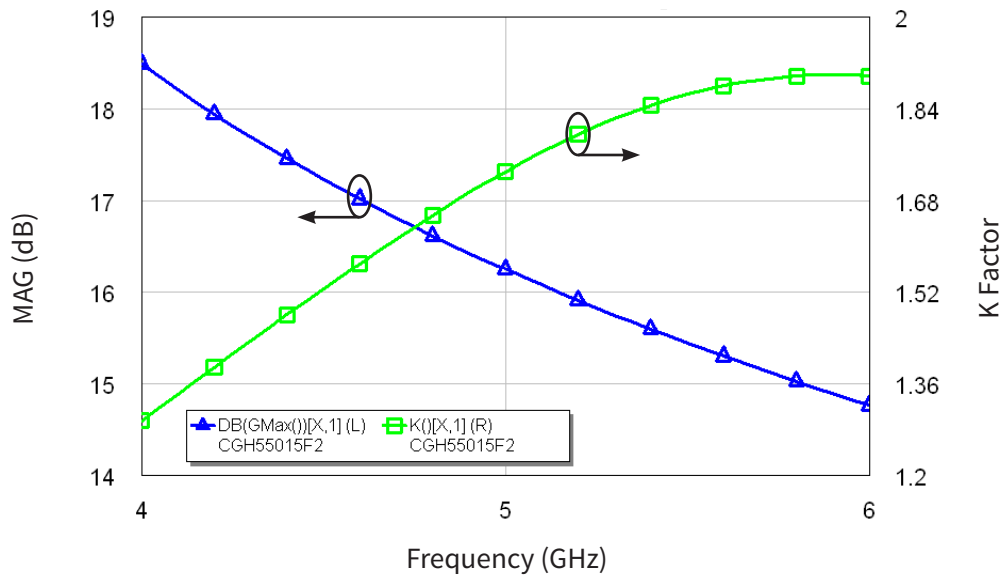

**Typical Noise Performance**

**Figure 6. Simulated Minimum Noise Figure and Noise Resistance vs Frequency of the CGH27060**

$V_{DD} = 28\text{ V}, I_{DQ} = 100\text{ mA}$

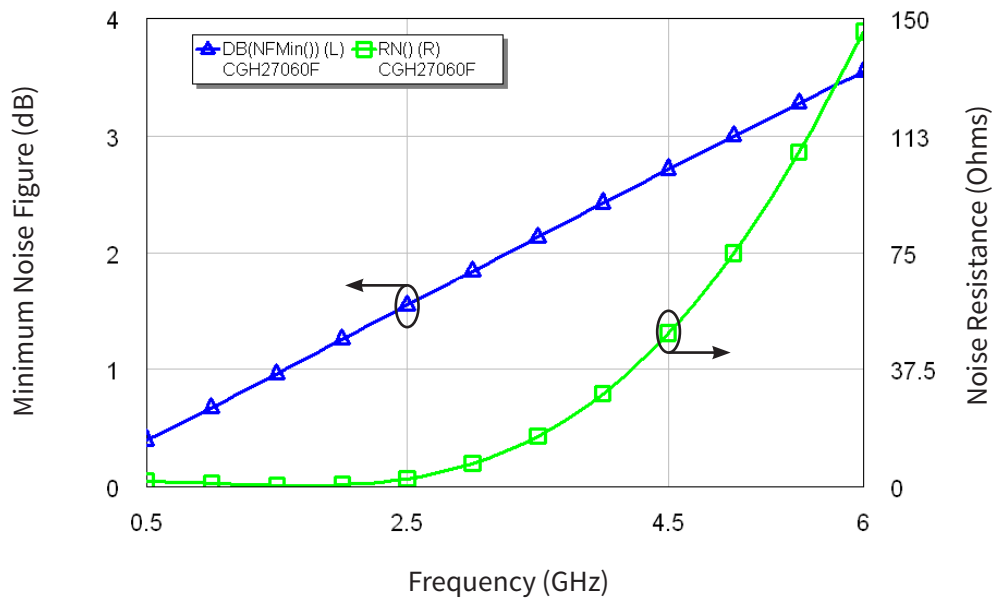

**Electrostatic Discharge (ESD) Classifications**

Parameter	Symbol	Class	Test Methodology
Human Body Model	HBM	1A (> 250 V)	JEDEC JESD22 A114-D
Charge Device Model	CDM	II (200 < 500 V)	JEDEC JESD22 C101-C



### Source and Load Impedances

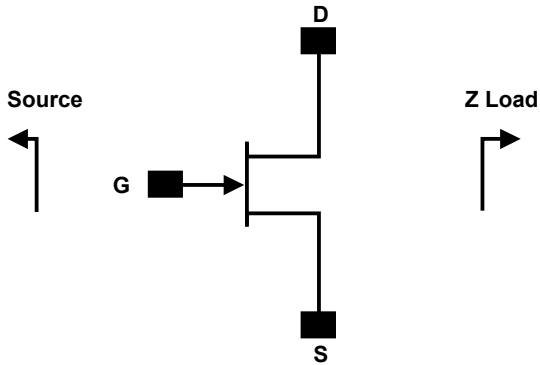

Frequency	Z Source	Z Lead
500	3.34 + j4.56	10.8 - j8.24
1000	2.07 - j0.05	6.18 - j4.17
2000	1.3 - j3.37	4.65 - j0.05
3000	1.64 - j8.15	4.75 - j3.4
4000	1.9 - j10.8	4.56 - j7.9

Note<sup>1</sup>.  $V_{DD} = 28V$ ,  $I_{DQ} = 300$  mA in the 440193 package

Note<sup>2</sup>. Optimized for  $P_{SAT}$  and PAE

Note<sup>3</sup>. When using this device at low frequency, series resistors should be used to maintain amplifier stability

### CGH27060 Power Dissipation De-rating Curve

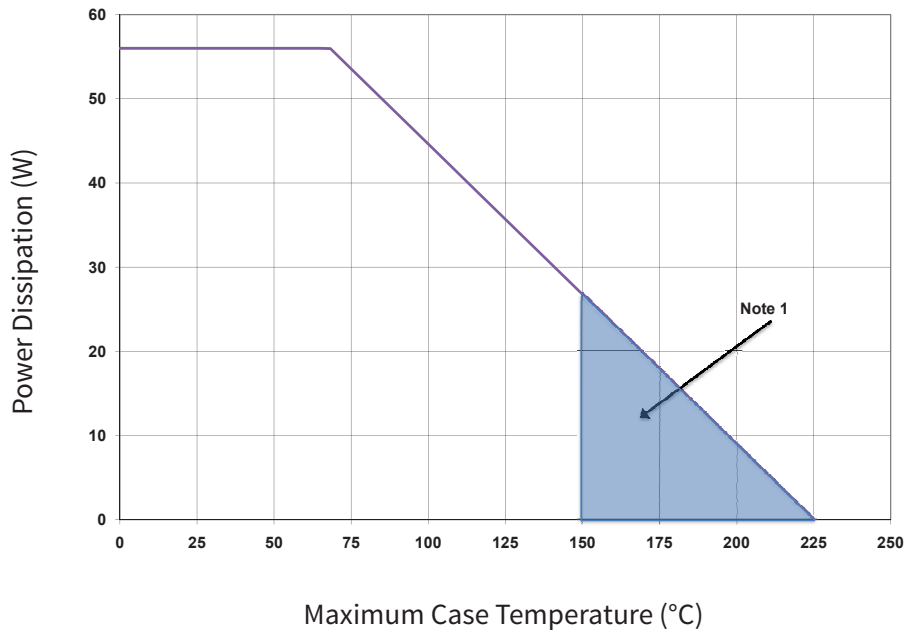

Note 1. Area exceeds Maximum Case Operating Temperature (See Page 2)

## CGH27060F-AMP Demonstration Amplifier Circuit Bill of Materials

Designator	Description	Qty
R1	RES, 1/16W, 0603, 1%, 5.1 OHMS	1
R2	RES, 1/16W, 0603, 1%, 100 OHMS	1
C6, C13, C19	CAP, 470PF, 10%,100V, 0603	3
C16, C22	CAP, 33 UF, 20%, G CASE	1
C15, C21	CAP, 1.0UF, 100V, 10%, X7R, 1210	1
C8	CAP 10UF 16V TANTALUM	1
C10	CAP, 8.2pF, +/-5%, 100B	1
C1	CAP, 0.9pF, +/-0.05pF, 0603	1
C2	CAP, 2.2pF, +/-0.1pF, 0603	1
C10, C11, C17	CAP, 10.0pF,+/-5%, 0603	3
C5, C12, C18, C30, C31	CAP, 82pF, +/-5%, 0603	5
C7, C14, C20	CAP,33000PF, 0805,100V, X7R	3
J2, J3	CONN SMA STR PANEL JACK RECP	1
J1	HEADER RT>PLZ .1CEN LK 9POS	1
-	PCB, RO4350B, Er = 3.48, h = 20 mil	1
-	CGH27060F	1

## CGH27060F-AMP Demonstration Amplifier Circuit

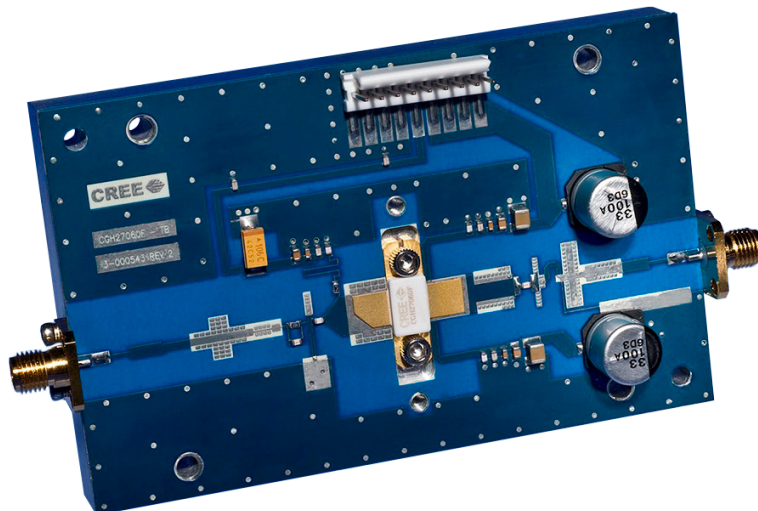



### CGH27060F-AMP Demonstration Amplifier Circuit Schematic

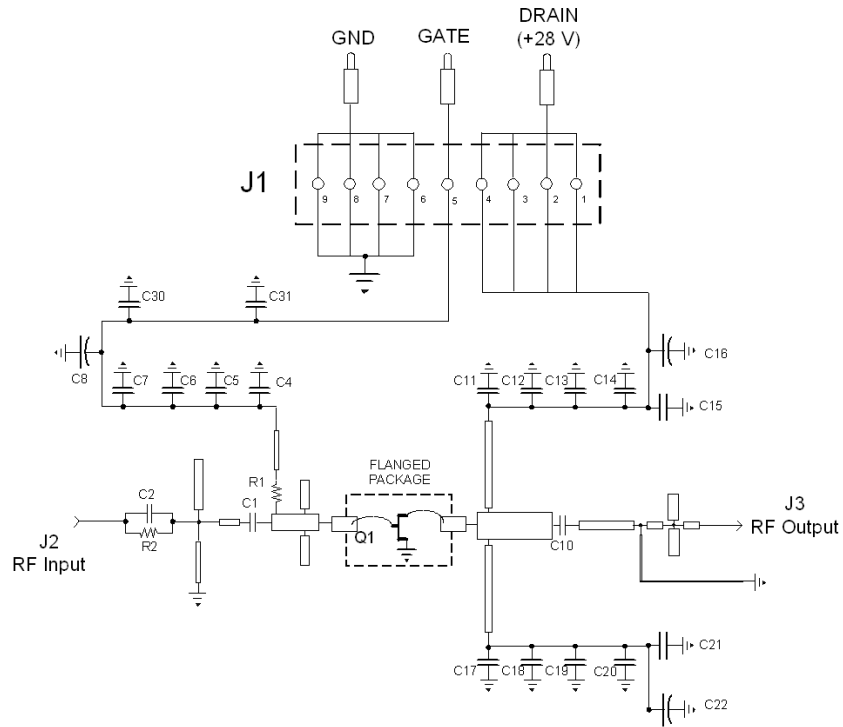

### CGH27060F-AMP Demonstration Amplifier Circuit Outline

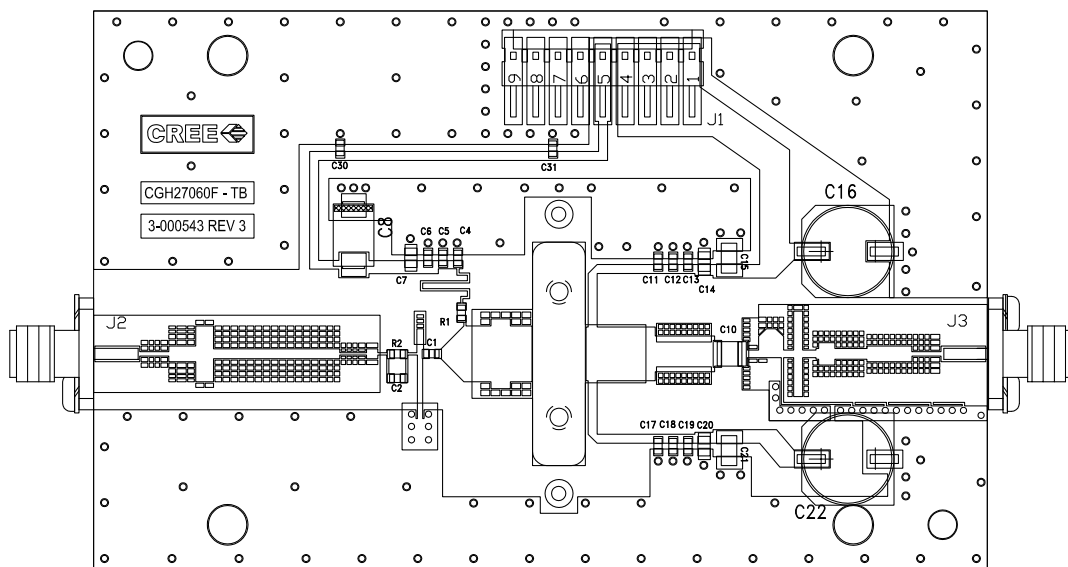



## Typical Package S-Parameters for CGH27060

(Small Signal,  $V_{DS} = 28\text{ V}$ ,  $I_{DQ} = 300\text{ mA}$ , angle in degrees)

Frequency	Mag S11	Ang S11	Mag S21	Ang S21	Mag S12	Ang S12	Mag S22	Ang S22
500 MHz	0.935	-171.10	7.31	80.30	0.013	-4.81	0.629	-171.50
600 MHz	0.935	-173.48	6.08	76.43	0.013	-7.68	0.635	-171.81
700 MHz	0.936	-175.34	5.20	72.85	0.013	-10.25	0.642	-171.96
800 MHz	0.937	-176.87	4.54	69.47	0.013	-12.62	0.649	-172.04
900 MHz	0.937	-178.19	4.03	66.24	0.013	-14.82	0.656	-172.11
1.0 GHz	0.938	-179.38	3.62	63.13	0.013	-16.89	0.664	-172.18
1.1 GHz	0.939	179.54	3.28	60.12	0.013	-18.84	0.672	-172.28
1.2 GHz	0.939	178.52	3.00	57.20	0.012	-20.69	0.680	-172.42
1.3 GHz	0.940	177.55	2.77	54.36	0.012	-22.44	0.688	-172.60
1.4 GHz	0.941	176.60	2.57	51.59	0.012	-24.10	0.695	-172.83
1.5 GHz	0.942	175.68	2.39	48.89	0.012	-25.67	0.703	-173.11
1.6 GHz	0.942	174.77	2.24	46.24	0.012	-27.15	0.710	-173.42
1.7 GHz	0.943	173.87	2.11	43.66	0.012	-28.56	0.718	-173.78
1.8 GHz	0.943	172.96	2.00	41.12	0.011	-29.88	0.724	-174.18
1.9 GHz	0.944	172.04	1.90	38.63	0.011	-31.12	0.731	-174.61
2.0 GHz	0.944	171.11	1.81	36.19	0.011	-32.29	0.737	-175.07
2.1 GHz	0.944	170.16	1.73	33.78	0.011	-33.39	0.743	-175.57
2.2 GHz	0.944	169.19	1.67	31.41	0.011	-34.42	0.748	-176.10
2.3 GHz	0.945	168.19	1.61	29.06	0.011	-35.38	0.753	-176.65
2.4 GHz	0.944	167.16	1.55	26.74	0.010	-36.28	0.758	-177.23
2.5 GHz	0.944	166.10	1.51	24.43	0.010	-37.11	0.762	-177.83
2.6 GHz	0.944	165.00	1.47	22.14	0.010	-37.88	0.765	-178.45
2.7 GHz	0.944	163.85	1.43	19.85	0.010	-38.60	0.769	-179.10
2.8 GHz	0.943	162.64	1.41	17.56	0.010	-39.27	0.771	-179.77
2.9 GHz	0.942	161.38	1.38	15.27	0.010	-39.90	0.774	179.54
3.0 GHz	0.941	160.06	1.36	12.96	0.010	-40.48	0.776	178.82
3.2 GHz	0.939	157.18	1.34	8.27	0.010	-41.54	0.778	177.32
3.4 GHz	0.935	153.93	1.33	3.43	0.010	-42.52	0.779	175.73
3.6 GHz	0.931	150.21	1.34	-1.65	0.010	-43.50	0.778	174.01
3.8 GHz	0.925	145.88	1.37	-7.06	0.010	-44.60	0.774	172.17
4.0 GHz	0.916	140.74	1.43	-12.95	0.011	-45.95	0.769	170.17
4.2 GHz	0.906	134.55	1.50	-19.47	0.011	-47.77	0.760	167.98
4.4 GHz	0.891	126.90	1.61	-26.85	0.012	-50.32	0.749	165.56
4.6 GHz	0.872	117.26	1.75	-35.39	0.013	-53.96	0.733	162.84
4.8 GHz	0.848	104.85	1.92	-45.48	0.014	-59.15	0.713	159.74
5.0 GHz	0.817	88.57	2.14	-57.60	0.016	-66.44	0.688	156.11
5.2 GHz	0.784	67.16	2.37	-72.25	0.018	-76.37	0.654	151.74
5.4 GHz	0.759	39.85	2.58	-89.71	0.020	-89.30	0.609	146.35
5.6 GHz	0.757	8.00	2.70	-109.65	0.021	-104.92	0.546	139.55
5.8 GHz	0.788	-24.14	2.67	-130.98	0.022	-122.14	0.460	130.98
6.0 GHz	0.836	-52.18	2.49	-152.33	0.021	-139.60	0.347	119.94

To download the s-parameters in s2p format, go to the [CGH27060F](#) Product page and click on the documentation tab.

**Product Dimensions CGH27060F (Package Type — 440193)**

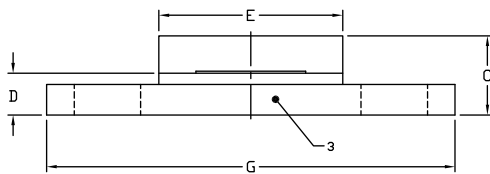
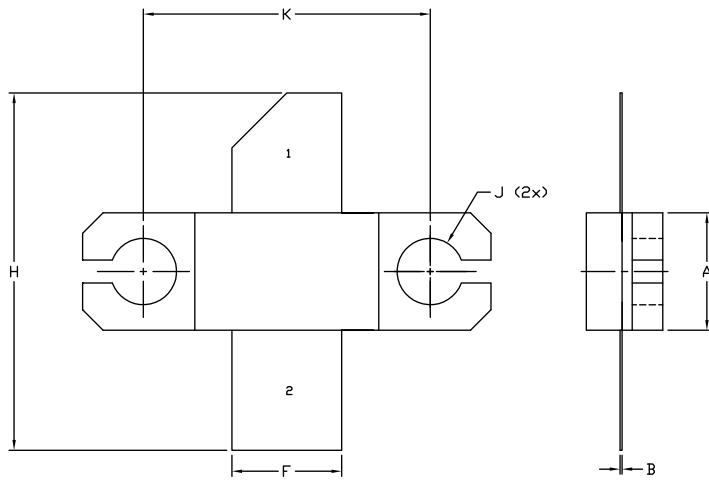

**NOTES:**

1. DIMENSIONING AND TOLERANCING PER ANSI Y14.5M, 1982.
2. CONTROLLING DIMENSION: INCH.
3. ADHESIVE FROM LID MAY EXTEND A MAXIMUM OF 0.020" BEYOND EDGE OF LID.
4. LID MAY BE MISALIGNED TO THE BODY OF THE PACKAGE BY A MAXIMUM OF 0.008" IN ANY DIRECTION.
5. ALL PLATED SURFACES ARE Ni/AU

DIM	INCHES		MILLIMETERS	
	MIN	MAX	MIN	MAX
A	0.225	0.235	5.72	5.97
B	0.004	0.006	0.10	0.15
C	0.145	0.165	3.68	4.19
D	0.077	0.087	1.96	2.21
E	0.355	0.365	9.02	9.27
F	0.210	0.220	5.33	5.59
G	0.795	0.805	20.19	20.45
H	0.670	0.730	17.02	18.54
J	∅ .130		3.30	
k	0.562		14.28	

- PIN 1. GATE  
 PIN 2. DRAIN  
 PIN 3. SOURCE



**Product Ordering Information**

Order Number	Description	Unit of Measure	Image
CGH27060F	GaN HEMT	Each	
CGH27060F-AMP	Test board with GaN HEMT installed	Each	



For more information, please contact:

4600 Silicon Drive  
Durham, North Carolina, USA 27703  
[www.wolfspeed.com/RF](http://www.wolfspeed.com/RF)

Sales Contact  
RFSales@cree.com

## Notes

---

### Disclaimer

Specifications are subject to change without notice. “Typical” parameters are the average values expected by Cree in large quantities and are provided for information purposes only. Cree products are not warranted or authorized for use as critical components in medical, life-saving, or life-sustaining applications, or other applications where a failure would reasonably be expected to cause severe personal injury or death. No responsibility is assumed by Cree for any infringement of patents or other rights of third parties which may result from use of the information contained herein. No license is granted by implication or otherwise under any patent or patent rights of Cree.