

CGHV40050

50 W, DC - 4.0 GHz, 50 V, GaN HEMT

Description

Cree's CGHV40050 is an unmatched, gallium nitride (GaN) high electron mobility transistor (HEMT). The CGHV40050, operating from a 50 volt rail, offers a general purpose, broadband solution to a variety of RF and microwave applications up to 4 GHz. The reference HPA design in the datasheet operates from 800 MHz to 2 GHz operation instantaneously. It is a demonstration amplifier to showcase the CGHV40050's high efficiency, high gain and wide bandwidth capabilities. The device can be used for a range of applications from narrow band UHF, L and S Band as well as multi-octave bandwidth amplifiers up to 4 GHz. The transistor is available in a 2-lead flange and pill package.

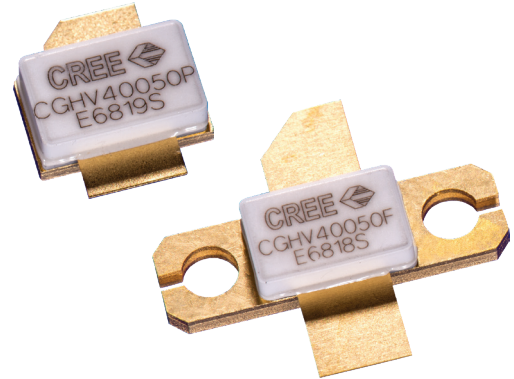

Package Types: 440193 & 440206
PNs: CGHV40050F & CGHV40050P

Typical Performance Over 800 MHz - 2.5 GHz ($T_c = 25^\circ\text{C}$), 50 V

Parameter	800 MHz	1.2 GHz	1.4 GHz	1.8 GHz	2.0 GHz	Units
Small Signal Gain	17.6	16.9	17.7	17.5	14.8	dB
Saturated Output Power	65	70	63	77	60	W
Drain Efficiency @ P_{SAT}	63	63	60	53	52	%
Input Return Loss	5	5.5	4.2	8	5	dB

Note: Measured CW in the CGHV40050F-AMP application circuit.

Features

- Up to 4 GHz Operation
- 77 W Typical Output Power
- 17.5 dB Small Signal Gain at 1.8 GHz
- Application Circuit for 0.8 - 2.0 GHz
- 53% Efficiency at P_{SAT}
- 50 V Operation

 Large Signal Models Available for ADS and MWO

RoHS
COMPLIANT



Absolute Maximum Ratings (not simultaneous) at 25 °C Case Temperature

Parameter	Symbol	Rating	Units	Conditions
Drain-Source Voltage	V_{DSS}	150	Volts	25 °C
Gate-to-Source Voltage	V_{GS}	-10, +2	Volts	25 °C
Storage Temperature	T_{STG}	-65, +150	°C	
Operating Junction Temperature	T_J	225	°C	
Maximum Forward Gate Current	I_{GMAX}	10.4	mA	25 °C
Maximum Drain Current ¹	I_{DMAX}	6.3	A	25 °C
Soldering Temperature ²	T_S	245	°C	
Screw Torque	τ	40	in-oz	
Thermal Resistance, Junction to Case ³	$R_{\theta JC}$	3.04	°C/W	85 °C
Thermal Resistance, Junction to Case ⁴	$R_{\theta JC}$	3.11	°C/W	85 °C
Case Operating Temperature ⁵	T_C	-40, +80	°C	30 seconds

Notes:

¹ Current limit for long term, reliable operation

² Refer to the Application Note on soldering at wolfspeed.com/rf/document-library

³ Measured for the CGHV40050P at $P_{DISS} = 41.6$ W

⁴ Measured for the CGHV40050F at $P_{DISS} = 41.6$ W

⁵ See also, Power Derating Curve on Page 7

Electrical Characteristics ($T_C = 25$ °C)

Characteristics	Symbol	Min.	Typ.	Max.	Units	Conditions
DC Characteristics¹						
Gate Threshold Voltage	$V_{GS(th)}$	-3.8	-3.0	-2.3	V_{DC}	$V_{DS} = 10$ V, $I_D = 10.4$ mA
Gate Quiescent Voltage	$V_{GS(Q)}$	-	-2.7	-	V_{DC}	$V_{DS} = 50$ V, $I_D = 0.3$ A
Saturated Drain Current ²	I_{DS}	6.8	9.7	-	A	$V_{DS} = 6.0$ V, $V_{GS} = 2.0$ V
Drain-Source Breakdown Voltage	V_{BR}	100	-	-	V_{DC}	$V_{GS} = -8$ V, $I_D = 10.4$ mA
RF Characteristics³ ($T_C = 25$ °C, $F_0 = 1.8$ GHz unless otherwise noted)						
Small Signal Gain	G_{SS}	17.5	19	-	dB	$V_{DD} = 50$ V, $I_{DQ} = 0.3$ A
Power Gain	G_P	-	15.5	-	dB	$V_{DD} = 50$ V, $I_{DQ} = 0.3$ A, $P_{OUT} = P_{SAT}$
Output Power at Saturation ⁴	P_{SAT}	70	77	-	W	$V_{DD} = 50$ V, $I_{DQ} = 0.3$ A
Drain Efficiency	η	48	53	-	%	$V_{DD} = 50$ V, $I_{DQ} = 0.3$ A, $P_{OUT} = P_{SAT}$
Output Mismatch Stress	VSWR	-	-	10 : 1	Ψ	No damage at all phase angles, $V_{DD} = 50$ V, $I_{DQ} = 0.3$ A, $P_{OUT} = 50$ W CW
Dynamic Characteristics⁵						
Input Capacitance	C_{GS}	-	16	-	pF	$V_{DS} = 50$ V, $V_{GS} = -8$ V, $f = 1$ MHz
Output Capacitance	C_{DS}	-	5	-	pF	$V_{DS} = 50$ V, $V_{GS} = -8$ V, $f = 1$ MHz
Feedback Capacitance	C_{GD}	-	0.3	-	pF	$V_{DS} = 50$ V, $V_{GS} = -8$ V, $f = 1$ MHz

Notes:

¹ Measured on wafer prior to packaging

² Scaled from PCM data

³ Measured in CGHV40050-AMP

⁴ P_{SAT} is defined as $I_G = 1$ mA

⁵ Includes package



CGHV40050 Typical Performance

Figure 1. Small Signal Gain and Return Losses versus Frequency of the CGHV40050 in the application circuit CGHV40050-AMP

$V_{DD} = 50\text{ V}$, $I_{DQ} = 300\text{ mA}$, $T_{case} = 25^\circ\text{C}$

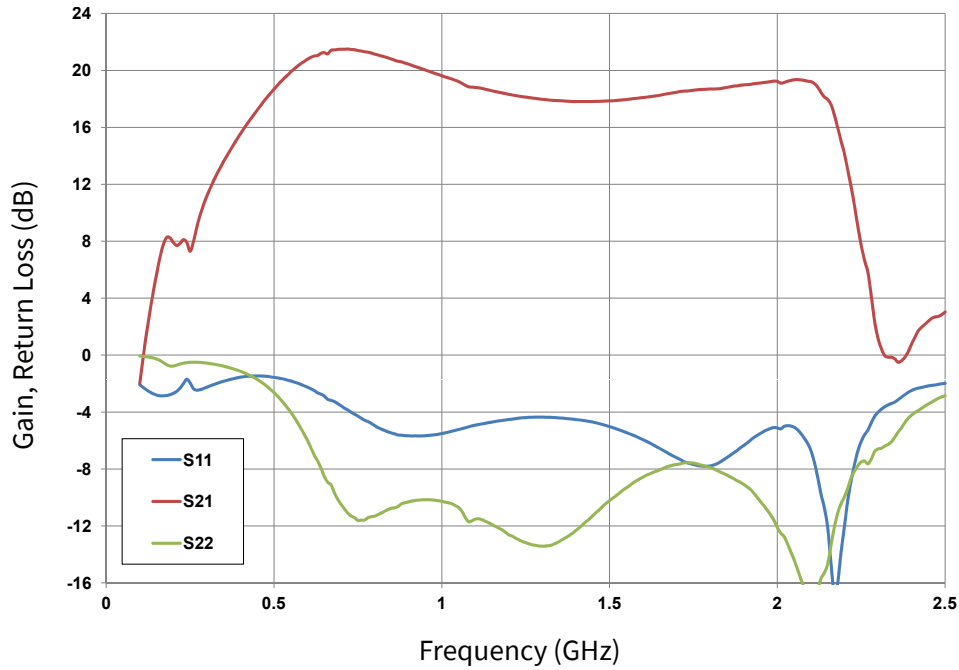
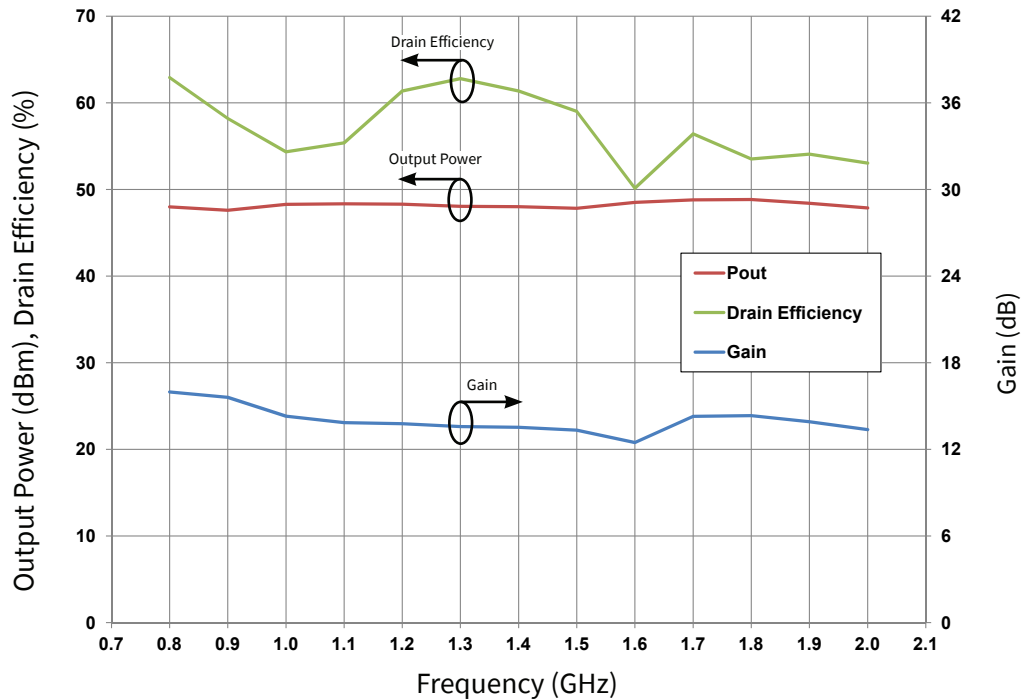

Figure 2. Gain, Output Power and Drain Efficiency vs Frequency of the CGHV40050 measured in Broadband Amplifier Circuit CGHV40050-AMP

$V_{DD} = 50\text{ V}$, $I_{DQ} = 300\text{ mA}$, $T_{case} = 25^\circ\text{C}$





CGHV40050 Typical Performance

Figure 3. G_{MAX} and K-Factor vs Frequency
 $V_{DD} = 50V, I_{DQ} = 300\text{ mA}, T_{case} = 25^{\circ}C$

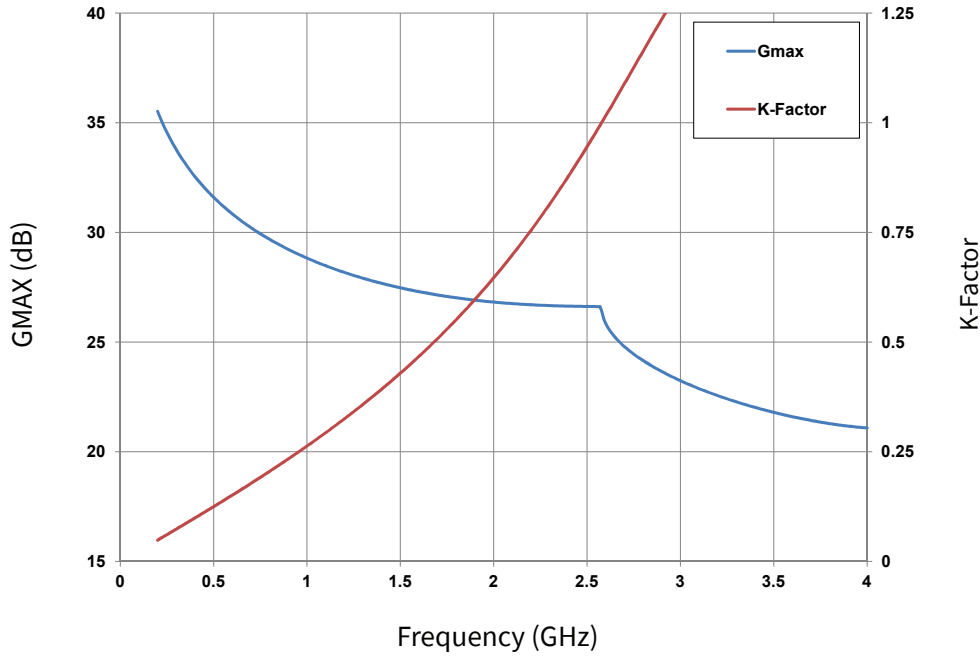

Source and Load Impedances

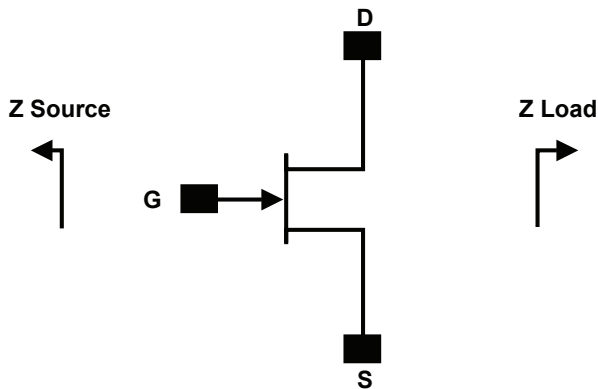

Frequency (MHz)	Z Source	Z Load
500	5.69+j7.82	21.47+j10.28
1000	3.21+j3.48	11.72+j10.50
2000	3.2-j1.74	3.84+j7.07
3000	3.23-j5.23	5.58+j3.02
4000	2.75-j10.6	4.65-j0.74

Note: $V_{DD} = 50\text{ V}, I_{DQ} = 300\text{ mA}$ in the 440193 package



CGHV40050-AMP Application Circuit Schematic

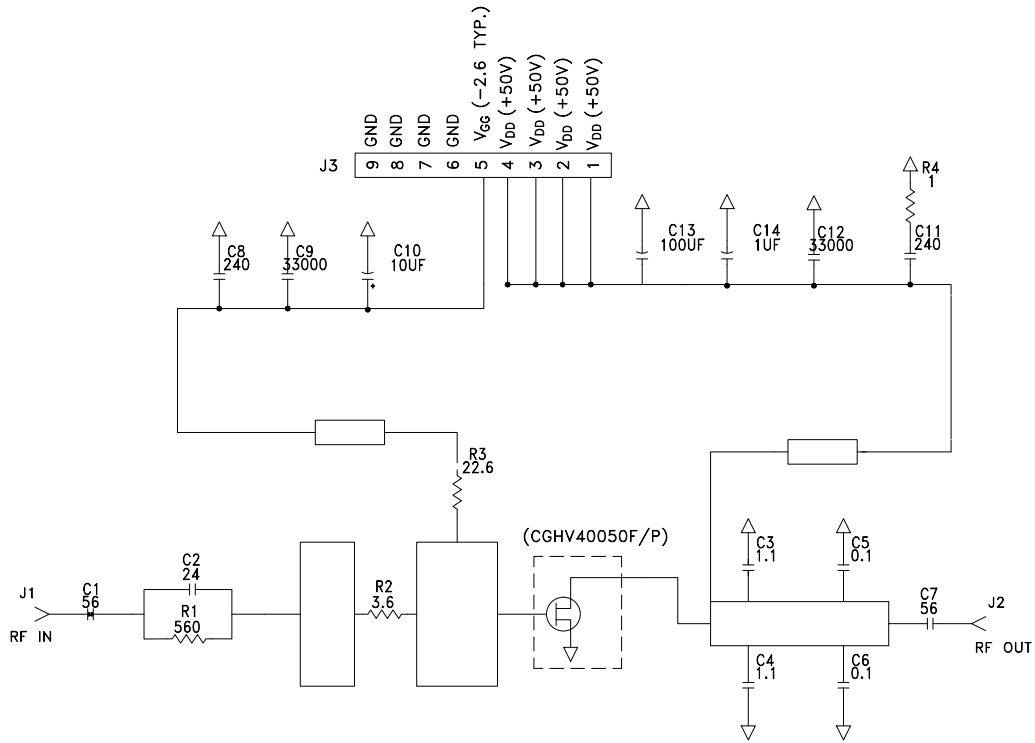

CGHV40050-AMP Application Circuit

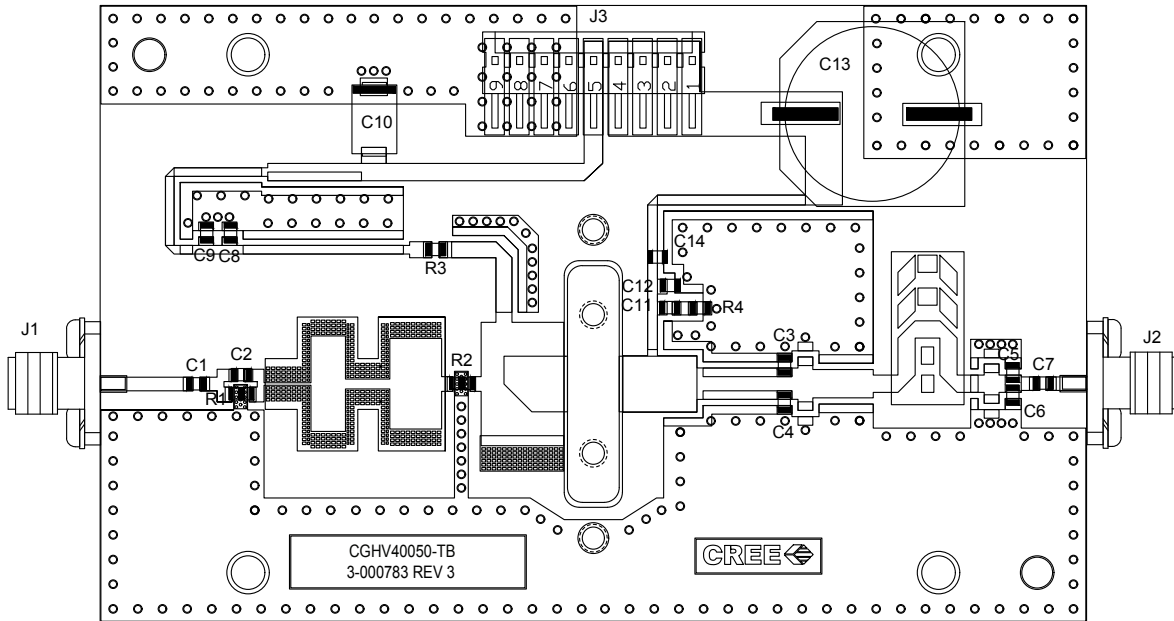

CGHV40050-AMP Application Circuit Bill of Materials

Designator	Description	Qty
R1	RES, 560Ohms, 0805, HIGH POWER SMT	1
R2	RES, 3.6Ohms, 1005, HIGH POWER SMT	1
R3	RES, SMT, 0805, 22 OHM	1
R4	RES, SMT, 0805, 1OHM	1
C1, C7	CAP, 56 PF +/- 5%, 250V, 0805, ATC 600F	3
C2	CAP, 24 pF +/- 5%, 250V, 0805, ATC 600F	1
C3, C4	CAP, 1.1pF, +/-0.1pF, 250V, 0805, ATC600F	2
C5, C6	CAP, 0.1 PF +/- 0.05 pF, 0805, ATC 600F	2
C8, C11	CAP, 240pF, +/-5%, 0805, ATC600F	2
C9, C12	CAP, 33000pF, 0805, 100V, X7R	2
C10	CAP, 10UF, 16V, TANTALUM	1
C13	CAP, 100UF, 80V, ELECTROLYTIC, CAN	1
C14	CAP, 1UF, 0805, 100V, X7S	1
J1,J2	CONN, SMA, PANEL MOUNT JACK, FLANGE, 4-HOLE, BLUNT POST	2
J3	HEADER RT>PLZ .1CEN LK 9POS	1
-	BASEPLATE, CGH35120	1
-	PCB, RO4350B, 2.5"x4"x0.020", CGHV40050F	1

CGHV40050-AMP Demonstration Amplifier Circuit

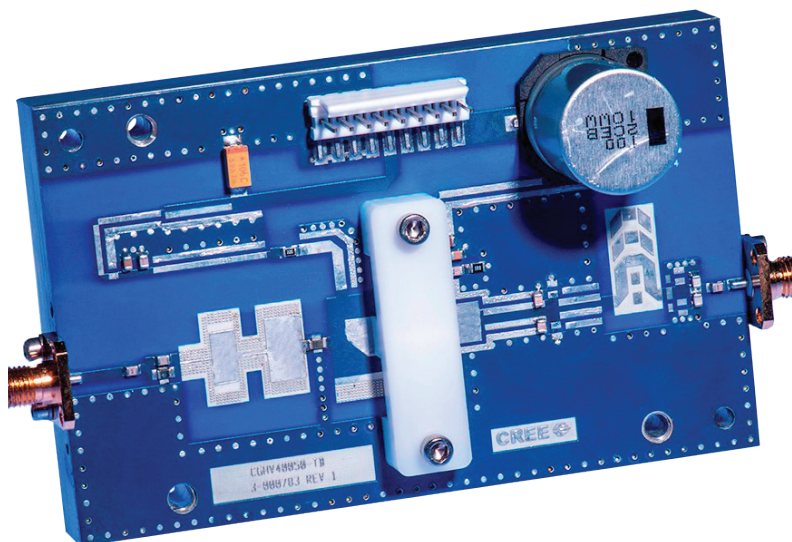



CGHV40050 Power Dissipation De-rating Curve

Figure 4. Transient Power Dissipation De-Rating Curve

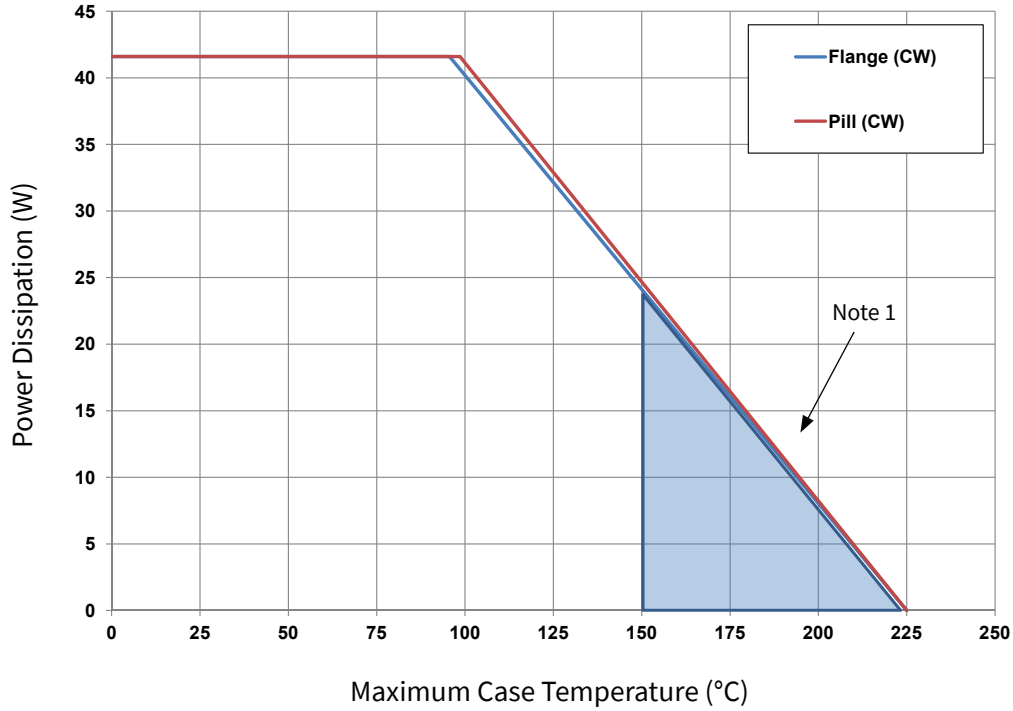

Note 1. Area exceeds Maximum Case Operating Temperature (See Page 2).

Electrostatic Discharge (ESD) Classifications

Parameter	Symbol	Class	Test Methodology
Human Body Model	HBM	1A (> 250 V)	JEDEC JESD22 A114-D
Charge Device Model	CDM	II (200 < 500 V)	JEDEC JESD22 C101-C



Typical S-Parameters (Small Signal, $V_{DS} = 50\text{ V}$, $I_{DQ} = 300\text{ mA}$, magnitude / angle)

Frequency	Mag S11	Ang S11	Mag S21	Ang S21	Mag S12	Ang S12	Mag S22	Ang S22
500 MHz	0.92	-161.97	13.79	79.27	0.01	-5.56	0.44	-142.42
600 MHz	0.92	-165.42	11.38	74.02	0.01	-9.73	0.46	-143.34
700 MHz	0.92	-168.02	9.62	69.31	0.01	-13.32	0.49	-144.16
800 MHz	0.93	-170.08	8.29	64.99	0.01	-16.49	0.52	-145.04
900 MHz	0.93	-171.8	7.24	60.98	0.009	-19.32	0.55	-146.01
1.0 GHz	0.93	-173.27	6.4	57.23	0.009	-21.83	0.58	-147.07
1.1 GHz	0.93	-174.58	5.7	53.71	0.009	-24.07	0.61	-148.21
1.2 GHz	0.94	-175.77	5.13	50.38	0.008	-26.05	0.63	-149.4
1.3 GHz	0.94	-176.86	4.64	47.24	0.008	-27.77	0.65	-150.62
1.4 GHz	0.94	-177.89	4.23	44.25	0.007	-29.25	0.67	-151.85
1.5 GHz	0.94	-178.87	3.87	41.42	0.007	-30.48	0.69	-153.09
1.6 GHz	0.94	-179.81	3.56	38.72	0.007	-31.46	0.71	-154.33
1.7 GHz	0.95	179.28	3.3	36.14	0.006	-32.19	0.73	-155.54
1.8 GHz	0.95	178.4	3.06	33.68	0.006	-32.66	0.74	-156.74
1.9 GHz	0.95	177.53	2.85	31.32	0.006	-32.85	0.76	-157.91
2.0 GHz	0.95	176.67	2.67	29.06	0.005	-32.75	0.77	-159.06
2.1 GHz	0.95	175.82	2.51	26.88	0.005	-32.33	0.78	-160.18
2.2 GHz	0.95	174.97	2.37	24.78	0.005	-31.57	0.79	-161.28
2.3 GHz	0.95	174.13	2.24	22.75	0.005	-30.43	0.8	-162.34
2.4 GHz	0.96	173.28	2.12	20.78	0.004	-28.87	0.81	-163.39
2.5 GHz	0.96	172.43	2.02	18.87	0.004	-26.86	0.82	-164.4
2.6 GHz	0.96	171.57	1.93	17.02	0.004	-24.35	0.82	-165.4
2.7 GHz	0.96	170.7	1.85	15.2	0.004	-21.31	0.83	-166.37
2.8 GHz	0.96	169.82	1.77	13.43	0.003	-17.72	0.84	-167.32
2.9 GHz	0.96	168.92	1.71	11.69	0.003	-13.6	0.84	-168.25
3.0 GHz	0.96	168.01	1.65	9.98	0.003	-8.98	0.85	-169.17
3.2 GHz	0.96	166.12	1.55	6.62	0.003	1.31	0.86	-170.95
3.4 GHz	0.96	164.13	1.47	3.33	0.003	11.88	0.86	-172.69
3.6 GHz	0.96	162	1.41	0.06	0.004	21.35	0.87	-174.4
3.8 GHz	0.95	159.72	1.36	-3.22	0.004	28.89	0.87	-176.09
4.0 GHz	0.95	157.25	1.33	-6.55	0.005	34.35	0.88	-177.76

To download the s-parameters in s2p format, go to the [CGHV40050](#) Product page and click on the documentation tab.



Product Dimensions CGHV40050F (Package Type — 440193)

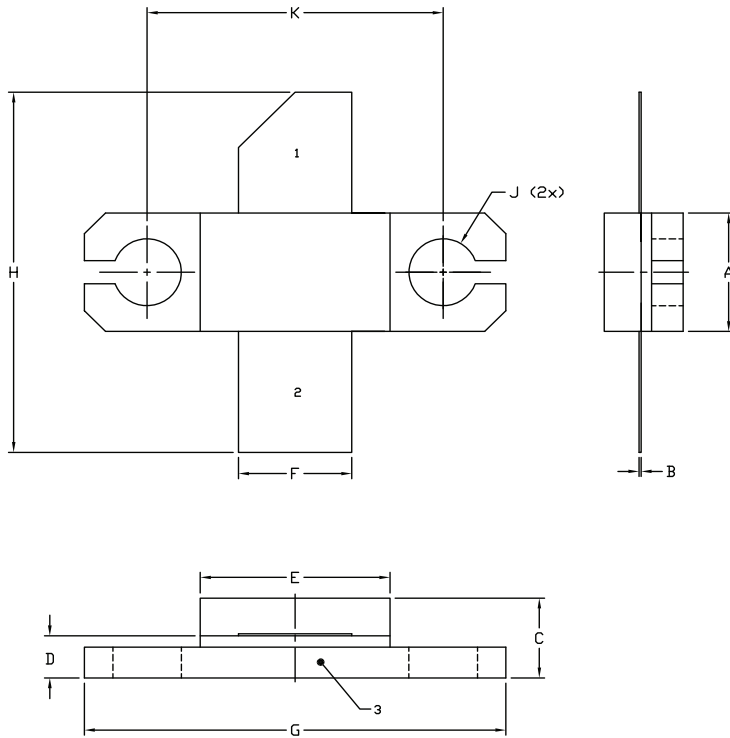

- NOTES:
1. DIMENSIONING AND TOLERANCING PER ANSI Y14.5M, 1982.
 2. CONTROLLING DIMENSION: INCH.
 3. ADHESIVE FROM LID MAY EXTEND A MAXIMUM OF 0.020" BEYOND EDGE OF LID.
 4. LID MAY BE MISALIGNED TO THE BODY OF THE PACKAGE BY A MAXIMUM OF 0.008" IN ANY DIRECTION.
 5. ALL PLATED SURFACES ARE Ni/AU

DIM	INCHES		MILLIMETERS	
	MIN	MAX	MIN	MAX
A	0.225	0.235	5.72	5.97
B	0.004	0.006	0.10	0.15
C	0.145	0.165	3.68	4.19
D	0.077	0.087	1.96	2.21
E	0.355	0.365	9.02	9.27
F	0.210	0.220	5.33	5.59
G	0.795	0.805	20.19	20.45
H	0.670	0.730	17.02	18.54
J	ø .130		3.30	
k	0.562		14.28	

- PIN 1. GATE
 PIN 2. DRAIN
 PIN 3. SOURCE

Product Dimensions CGHV40050P (Package Type — 440206)

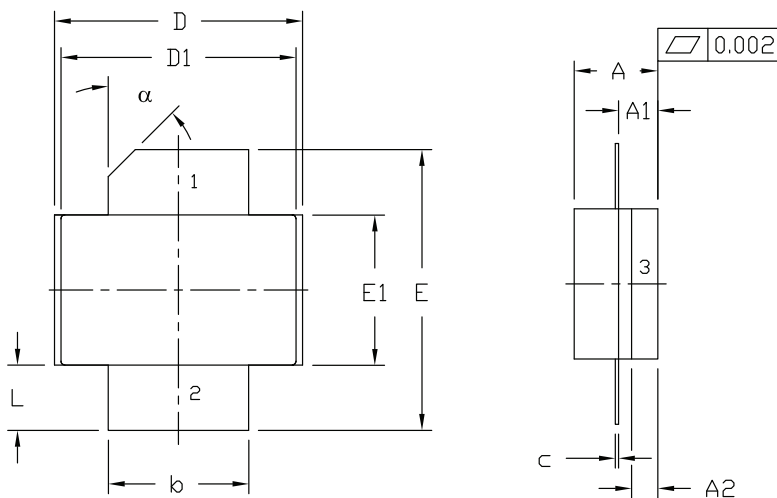



- NOTES:
1. DIMENSIONING AND TOLERANCING PER ANSI Y14.5M - 1994.
 2. CONTROLLING DIMENSION: INCH.
 3. ADHESIVE FROM LID MAY EXTEND A MAXIMUM OF 0.020" BEYOND EDGE OF LID.
 4. LID MAY BE MISALIGNED TO THE BODY OF PACKAGE BY A MAXIMUM OF 0.008" IN ANY DIRECTION.

DIM	INCHES		MILLIMETERS		NOTES
	MIN	MAX	MIN	MAX	
A	0.125	0.145	3.18	3.68	
A1	0.057	0.067	1.45	1.70	
A2	0.035	0.045	0.89	1.14	
b	0.210	0.220	5.33	5.59	2x
c	0.004	0.006	0.10	0.15	2x
D	0.375	0.385	9.53	9.78	
D1	0.355	0.365	9.02	9.27	
E	0.400	0.460	10.16	11.68	
E1	0.225	0.235	5.72	5.97	
L	0.085	0.115	2.16	2.92	2x
α	45° REF		45° REF		

- PIN 1. GATE
 PIN 2. DRAIN
 PIN 3. SOURCE

Product Ordering Information

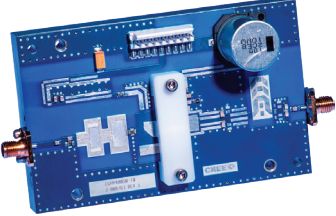
Order Number	Description	Unit of Measure	Image
CGHV40050F	GaN HEMT	Each	
CGHV40050P	GaN HEMT	Each	
CGHV40050F-AMP	Test board with GaN HEMT installed	Each	



For more information, please contact:

4600 Silicon Drive
Durham, North Carolina, USA 27703
www.wolfspeed.com/rf

Sales Contact
rfsales@cree.com

Notes & Disclaimer

Specifications are subject to change without notice. “Typical” parameters are the average values expected by Cree in large quantities and are provided for information purposes only. Cree products are not warranted or authorized for use as critical components in medical, life-saving, or life-sustaining applications, or other applications where a failure would reasonably be expected to cause severe personal injury or death. No responsibility is assumed by Cree for any infringement of patents or other rights of third parties which may result from use of the information contained herein. No license is granted by implication or otherwise under any patent or patent rights of Cree.

© 2015 – 2021 Cree, Inc. All rights reserved. Wolfspeed® and the Wolfspeed logo are registered trademarks of Cree, Inc.