

CGHV14800

800 W, 960 - 1400 MHz, 50 V, GaN HEMT for L-Band Radar Systems



Package Type: 440117
PN: CGHV14800F

Description

Cree's CGHV14800 is a gallium nitride (GaN) high electron mobility transistor (HEMT) designed specifically with high efficiency, high gain and wide bandwidth capabilities, which makes the CGHV14800 ideal for 960 - 1400 MHz pulsed L-Band radar amplifier applications, such as air traffic control (ATC) radar, weather radar, penetration radars, antimissile system radars, target tracking radars and long range surveillance radars. The GaN HEMT typically operates at 50 V, typically delivering > 65% drain efficiency. The package options are ceramic/metal flange package.

Typical Performance Over 1.2 - 1.4 GHz (TC = 25 °C) of Demonstration Amplifier

Parameter	1.2 GHz	1.25 GHz	1.3 GHz	1.35 GHz	1.4 GHz	Units
Output Power	1000	940	940	920	910	W
Gain	15.5	15.2	15.2	15.1	15.1	dB
Drain Efficiency	74	73	73	69	67	%

Note: Measured in the CGHV14800F-AMP amplifier circuit, under 100 μsecs pulse width, 5% duty cycle, Pin = 44.5 dBm.

Features

- Reference design amplifier 1.2 - 1.4 GHz Operation
- 910 W Typical Output Power
- 14 dB Power Gain
- 70% Typical Drain Efficiency
- <0.3 dB Pulsed Amplitude Droop
- Internally input and output matched

 Large Signal Models Available for ADS and MWO

RoHS
COMPLIANT

Absolute Maximum Ratings (not simultaneous)

Parameter	Symbol	Rating	Units	Conditions
Drain-Source Voltage	V_{DSS}	150	Volts	25 °C
Gate-to-Source Voltage	V_{GS}	-10, +2	Volts	25 °C
Storage Temperature	T_{STG}	-65, +150	°C	
Operating Junction Temperature	T_J	225	°C	
Maximum Forward Gate Current	I_{GMAX}	132	mA	25 °C
Maximum DC Current ¹	I_{DMAX}	24	A	25 °C
Maximum Duty Cycle	D	5	%	
Soldering Temperature ²	T_S	245	°C	
Screw Torque	τ	40	in-oz	
Pulsed Thermal Resistance, Junction to Case ³	$R_{\theta JC}$	0.16	°C/W	$P_{DISS} = 664 \text{ W}, 100 \mu\text{sec}, 5\%, 85 \text{ °C}$
Case Operating Temperature ⁴	T_C	-40, +100	°C	$P_{DISS} = 664 \text{ W}, 100 \mu\text{sec}, 5\%$

Notes:

¹ Current limit for long term, reliable operation² Refer to the Application Note on soldering at www.wolfspeed.com/rf/document-library³ Measured for the CGHV14800F-AMP⁴ See also, the Power Dissipation De-rating Curve on Page 6**Electrical Characteristics ($T_C = 25 \text{ °C}$)**

Characteristics	Symbol	Min.	Typ.	Max.	Units	Conditions
DC Characteristics¹						
Gate Threshold Voltage	$V_{GS(th)}$	-3.8	-3.0	-2.3	V_{DC}	$V_{DS} = 10 \text{ V}, I_D = 132.8 \text{ mA}$
Gate Quiescent Voltage	$V_{GS(Q)}$	-	-2.7	-	V_{DC}	$V_{DS} = 50 \text{ V}, I_D = 800 \text{ mA}$
Saturated Drain Current ²	I_{DS}	86.3	123.5	-	A	$V_{DS} = 6.0 \text{ V}, V_{GS} = 2.0 \text{ V}$
Drain-Source Breakdown Voltage	V_{BR}	125	-	-	V_{DC}	$V_{GS} = -8 \text{ V}, I_D = 132.8 \text{ mA}$
RF Characteristics³ ($T_C = 25 \text{ °C}, F_0 = 1.3 \text{ GHz}$ unless otherwise noted)						
Output Power	P_{OUT}	804	977	-	W	$V_{DD} = 50 \text{ V}, I_{DQ} = 800 \text{ mA}, F = 1.2 \text{ GHz}, P_{IN} = 44.5 \text{ dBm}$
Drain Efficiency	D_E	62	71	-	%	$V_{DD} = 50 \text{ V}, I_{DQ} = 800 \text{ mA}, F = 1.2 \text{ GHz}, P_{IN} = 44.5 \text{ dBm}$
Output Power	P_{OUT}	795	933	-	W	$V_{DD} = 50 \text{ V}, I_{DQ} = 800 \text{ mA}, F = 1.23 \text{ GHz}, P_{IN} = 44.5 \text{ dBm}$
Drain Efficiency	D_E	63	71	-	%	$V_{DD} = 50 \text{ V}, I_{DQ} = 800 \text{ mA}, F = 1.23 \text{ GHz}, P_{IN} = 44.5 \text{ dBm}$
Output Power	P_{OUT}	750	912	-	W	$V_{DD} = 50 \text{ V}, I_{DQ} = 800 \text{ mA}, F = 1.4 \text{ GHz}, P_{IN} = 44.5 \text{ dBm}$
Drain Efficiency	D_E	57	67	-	%	$V_{DD} = 50 \text{ V}, I_{DQ} = 800 \text{ mA}, F = 1.4 \text{ GHz}, P_{IN} = 44.5 \text{ dBm}$
Pulsed Amplitude Droop	D	-	-0.3	-	dB	$V_{DD} = 50 \text{ V}, I_{DQ} = 800 \text{ mA}$
Output Mismatch Stress	VSWR	-	9 : 1	-	Y	No damage at all phase angles, $V_{DD} = 50 \text{ V}, I_{DQ} = 800 \text{ mA}, P_{IN} = 44.5 \text{ dBm}$ Pulsed
Dynamic Characteristics						
Input Capacitance	C_{GS}	-	326	-	pF	$V_{DS} = 50 \text{ V}, V_{GS} = -8 \text{ V}, f = 1 \text{ MHz}$
Output Capacitance	C_{DS}	-	643	-	pF	$V_{DS} = 50 \text{ V}, V_{GS} = -8 \text{ V}, f = 1 \text{ MHz}$
Feedback Capacitance	C_{GD}	-	3.9	-	pF	$V_{DS} = 50 \text{ V}, V_{GS} = -8 \text{ V}, f = 1 \text{ MHz}$

Notes:

¹ Measured on wafer prior to packaging² Scaled from PCM data³ Measured in CGHV14800F-AMP. Pulsed Width = 100 μs , Duty Cycle = 5%.



Typical Pulsed Performance

Saturated Output Power and Drain Efficiency vs Frequency of the CGHV14800F in the CGHV14800F-AMP
 $V_{DD} = 50\text{ V}$, $I_{DQ} = 800\text{ mA}$, Pulse Width = 100 μs , Duty Cycle = 5%

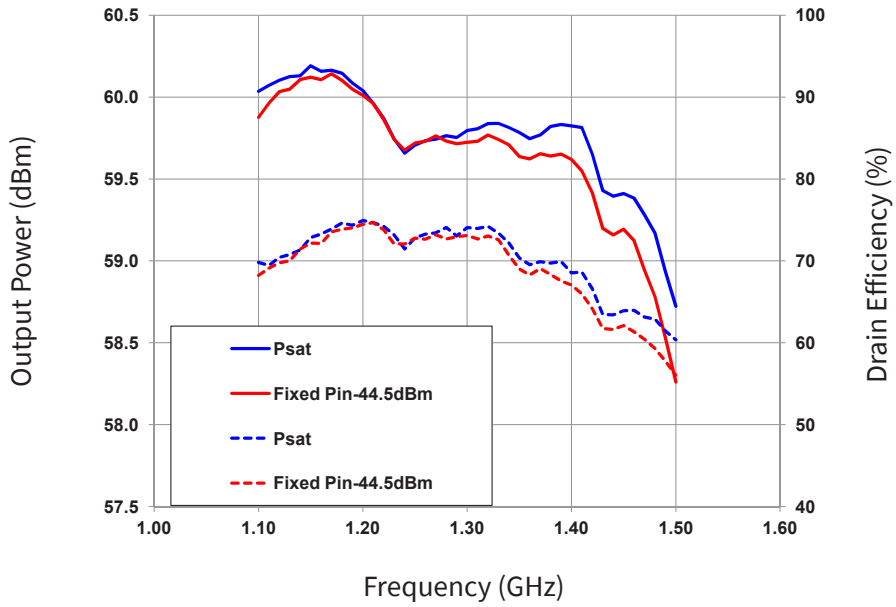

Small Signal Gain and Return Losses vs Frequency of the CGHV14800F in the CGHV14800F-AMP
 $V_{DD} = 50\text{ V}$, $I_{DQ} = 800\text{ mA}$

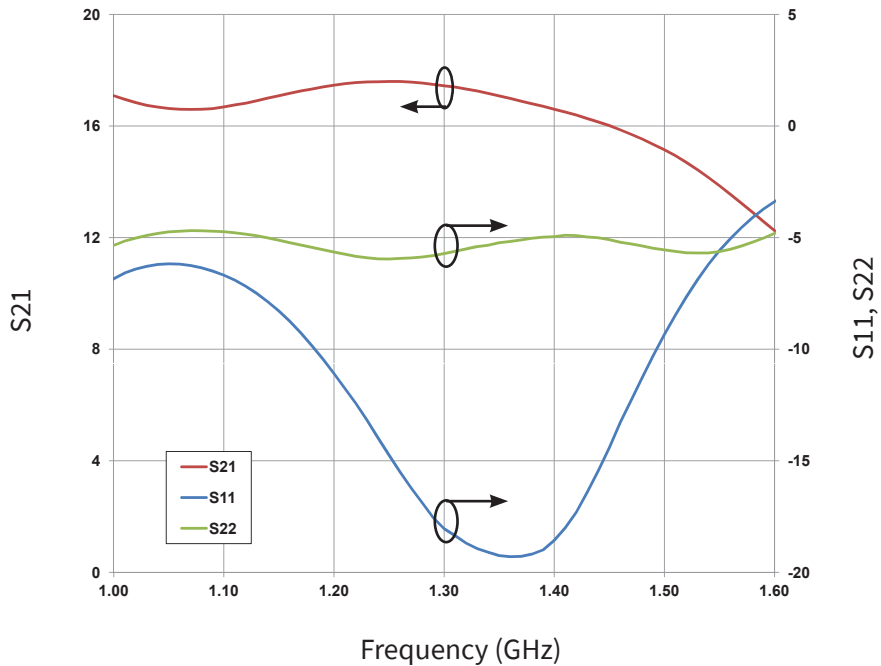

CGHV14800F-AMP Demonstration Amplifier Circuit Bill of Materials

Designator	Description	Qty
R2	RES,1/16W,0603,1%,4.99K OHMS	1
C3	CAP, 470PF, 5%, 100V, 0603, X7R, ROHS COMPLIANT	1
C5	CAP, 1.0UF, 100V, +/-10%, X7R, 1210	1
C11	CAP, 3300 UF, +/-20%, 100V, ELECTROLYTIC, VR, RADIAL	1
C16	CAP, 2.0pF, +/-0.1pF, 0603, ATC	1
C2	CAP, 33PF, +/-5%, 0603, ATC	1
C4,C9	CAP,33000PF, 0805,100V, X7R	2
C1	CAP, 100 PF +/- 5%, 250V, 0805, ATC 600F	1
C7	CAP, 33 PF +/- 5%, 250V, 0805, ATC 600F	1
	PCB, TMM10i, 0.025" THK, CGHV14800F-TB	1
	BASEPLATE, AL, 4.00 X 2.50 X 0.49, ALTERNATE HOLE PATTERN	1
	2-56 SOC HD SCREW 1/4 SS	4
	#2 SPLIT LOCKWASHER SS	4
J1,J2	CONN, SMA, PANEL MOUNT JACK, FLANGE, 4-HOLE, BLUNT POST	2
J3	HEADER RT>PLZ .1CEN LK 9POS	1
L1	INDUCTOR,CHIP,6.8nH,0603 SMT	1
W1	WIRE, BLACK, 18 AWG, EXTRUDED TFE TEFLON	1
J4	CONN, SMB, STRAIGHT JACK RECEPTACLE, SMT, 50 OHM, Au PLATED	1
C6	CAP 10UF 16V TANTALUM, 2312	1
R1,R4	RES,5.1 OHM,SMT,1206,125MW, 5%	2
R3	RES, 1/4W, 1206 1% 536 OHM	1
L2	IND, FERRITE, 220 OHM, 0805	1
C13	CAP, 3.0PF, ATC800B, +/-0.1PF	1
C12	CAP, 2.0PF, ATC800B, +/-0.1PF	1
C14,C15	CAP, 3.9 pF, +/-0.1pF, 250V, 0805, ATC600F	2
Q1	CGHV14800F	1



CGHV14800-AMP Demonstration Amplifier Circuit Outline

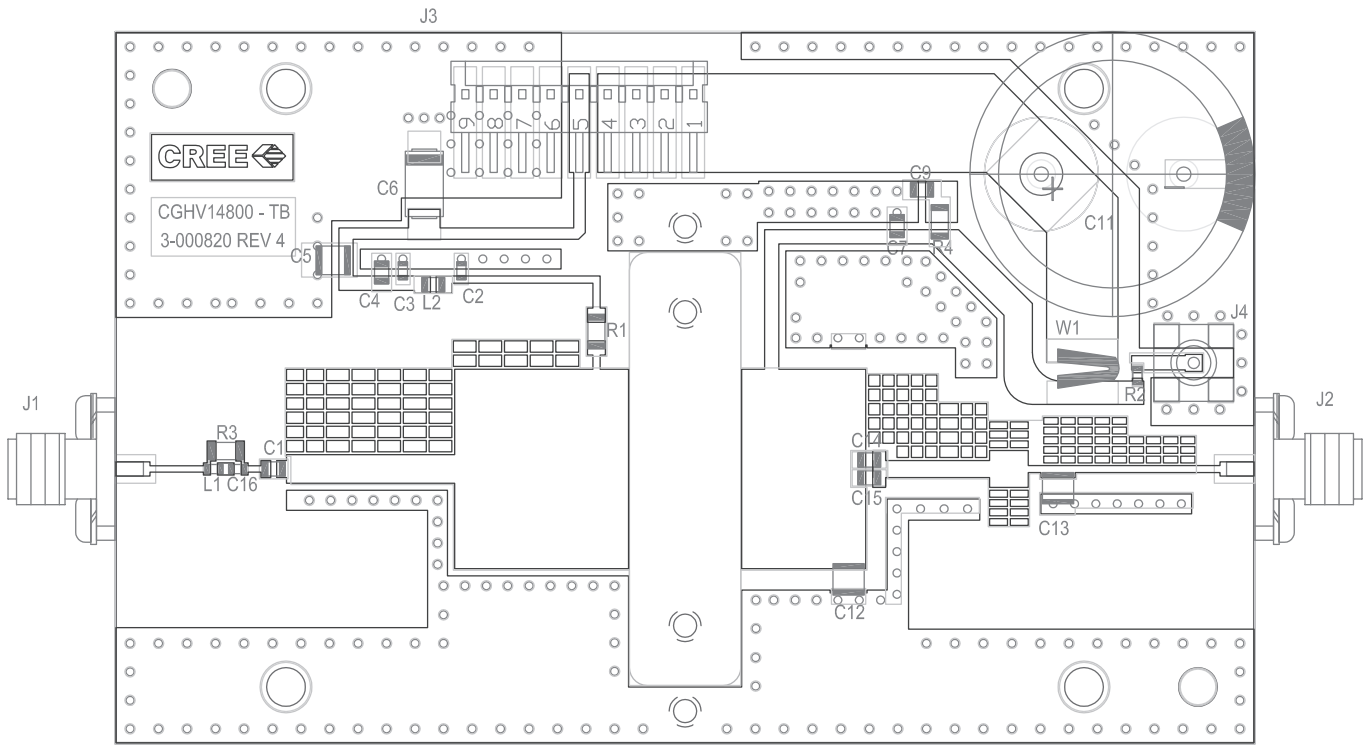

CGHV14800-AMP Demonstration Amplifier Circuit Schematic

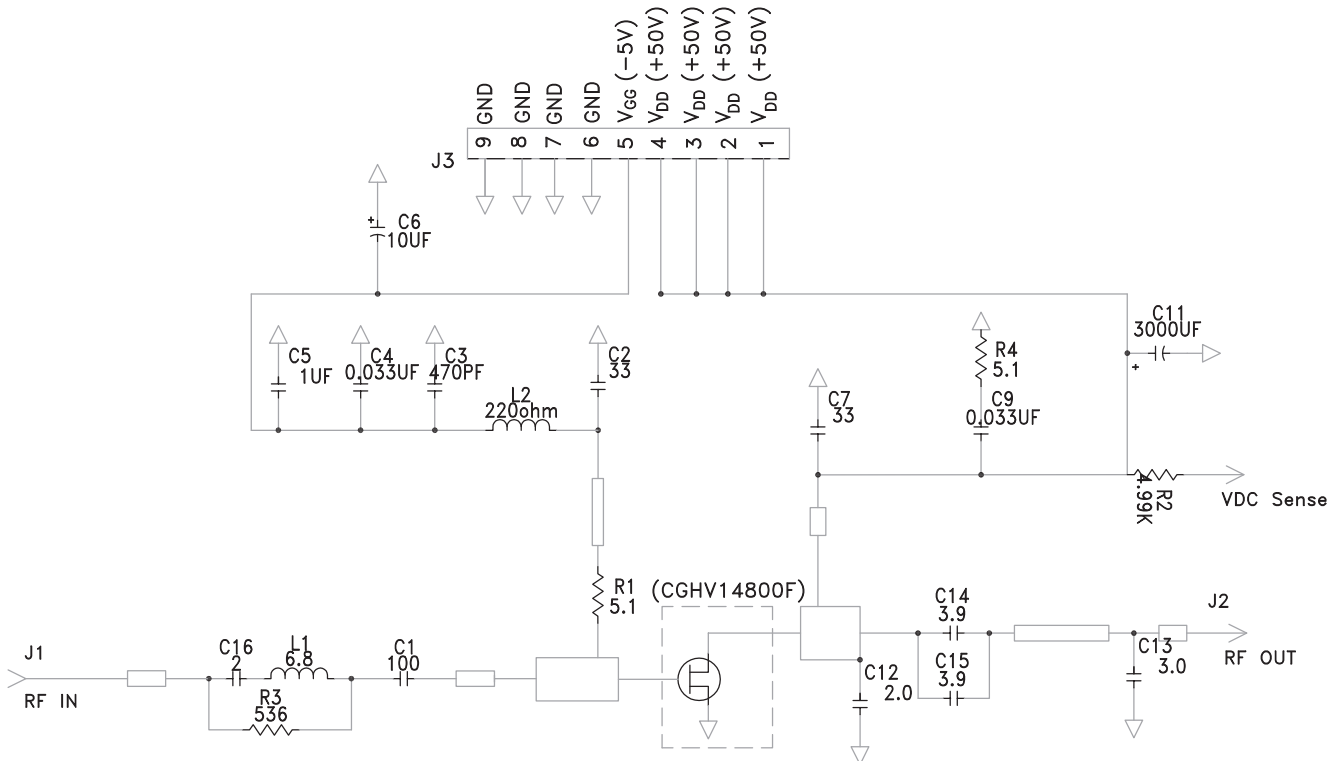



CGHV14800F-AMP Demonstration Amplifier Circuit

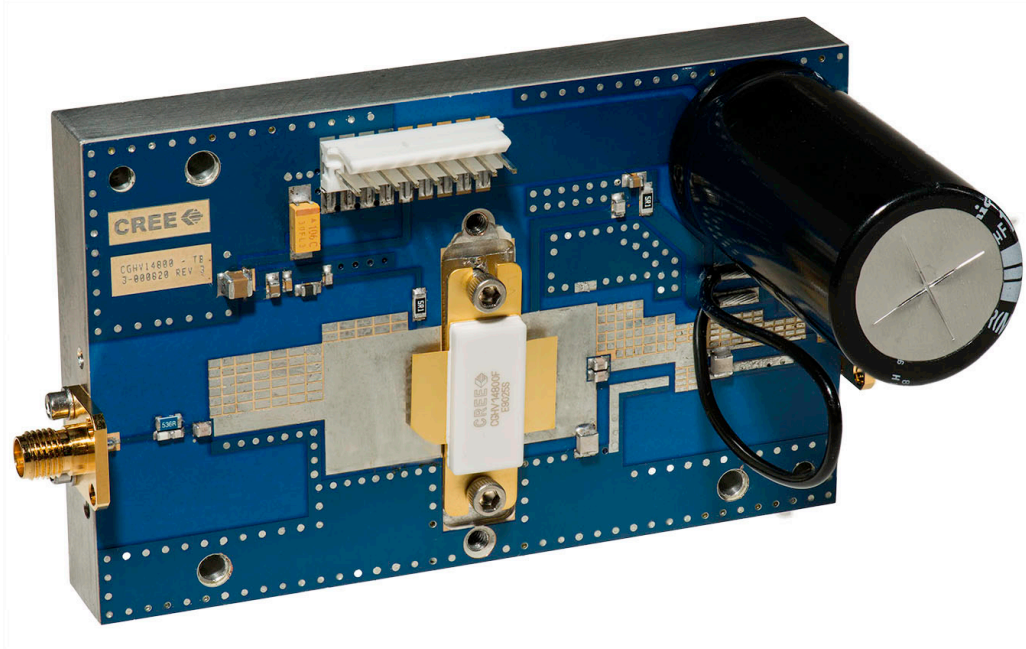

Product Dimensions CGHV14800F (Package Type — 440117)

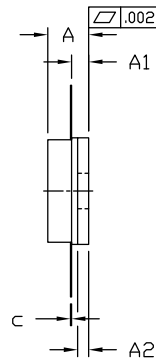
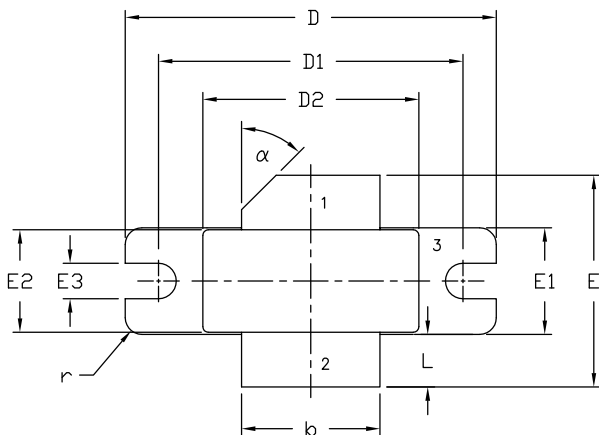

NOTES:

1. DIMENSIONING AND TOLERANCING PER ANSI Y14.5M - 1994.
2. CONTROLLING DIMENSION: INCH.
3. ADHESIVE FROM LID MAY EXTEND A MAXIMUM OF 0.020" BEYOND EDGE OF LID.
4. LID MAY BE MISALIGNED TO THE BODY OF PACKAGE BY A MAXIMUM OF 0.008" IN ANY DIRECTION.

DIM	INCHES		MILLIMETERS		NOTES
	MIN	MAX	MIN	MAX	
A	0.138	0.158	3.51	4.01	
A1	0.057	0.067	1.45	1.70	
A2	0.035	0.045	0.89	1.14	
b	0.495	0.505	12.57	12.83	2x
c	0.003	0.006	0.08	0.15	
D	1.335	1.345	33.91	34.16	
D1	1.095	1.105	27.81	28.07	
D2	0.773	0.787	19.63	20.00	
E	0.745	0.785	18.92	19.94	
E1	0.380	0.390	9.65	9.91	
E2	0.365	0.375	9.27	9.53	
E3	0.123	0.133	3.12	3.38	
L	0.170	0.210	4.32	5.33	2x
r	0.06	TYP	0.06	TYP	4x
α	45°	REF	45°	REF	

- PIN 1. GATE
 2. DRAIN
 3. SOURCE



Source and Load Impedances

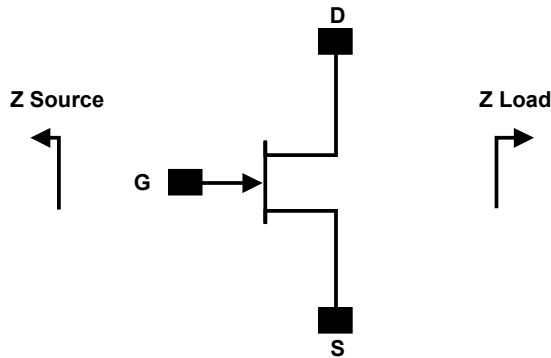

Frequency	Z Source	Z Load
1000	0.51 - j1.44	1.44 - j0.76
1100	0.92 - j1.62	1.30 - j1.55
1200	1.42 - j1.60	1.17 - j1.69
1300	1.79 - j1.04	116 - j1.85
1400	1.44 - j0.46	1.08 - j1.99
1500	0.87 - j0.42	1.07 - j2.13
1600	0.52 - j0.66	1.00 - j2.36

Note 1. $V_{DD} = 50\text{ V}$, $I_{DQ} = 800\text{ mA}$ in the 440117 package.
 Note 2. Optimized for power gain, P_{SAT} and Drain Efficiency

CGHV14800F Power Dissipation De-rating Curve

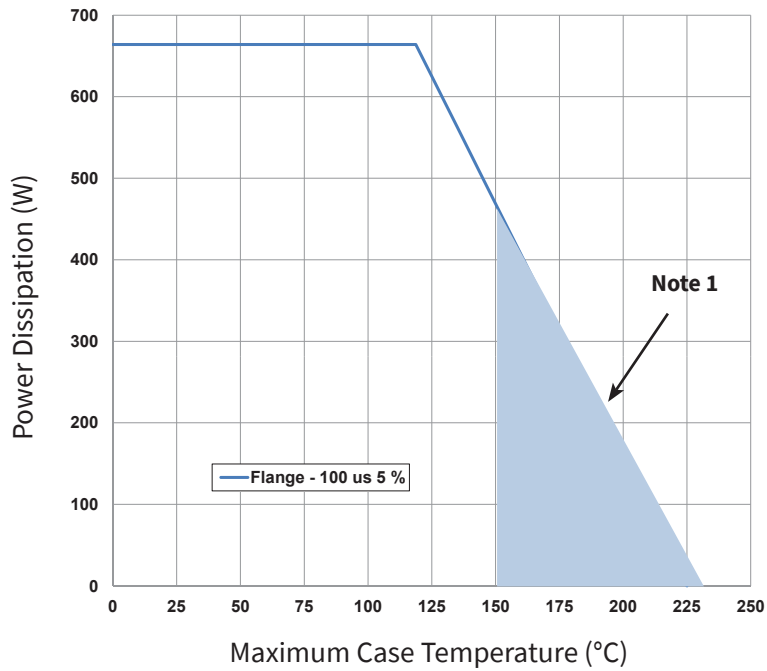

Note 1. Area exceeds Maximum Case Operating Temperature (See Page 2)



Part Number System

CGHV14800F

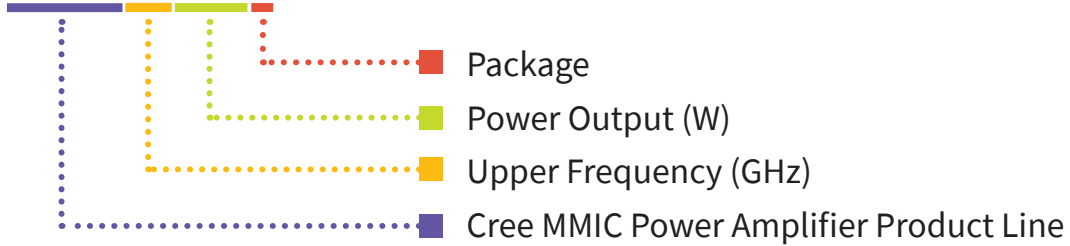

Table 1

Parameter	Value	Units
Upper Frequency ¹	1.4	GHz
Power Output	800	W
Type	F = Flanged P = Package	-

¹ Alpha characters used in frequency code indicate a value greater than 9.9 GHz. See Table 2 for value.

Table 2

Character Code	Code Value
A	0
B	1
C	2
D	3
E	4
F	5
G	6
H	7
J	8
K	9

Examples: 1A = 10.0 GHz
2H = 27.0 GHz



Product Ordering Information

Order Number	Description	Unit of Measure	Image
CGHV14800F	GaN HEMT	Each	
CGHV14800F-AMP	Test board with GaN HEMT installed, 1.2 - 1.4 GHz	Each	



For more information, please contact:

4600 Silicon Drive
Durham, North Carolina, USA 27703
www.wolfspeed.com/RF

Sales Contact
RFSales@cree.com

Notes

Disclaimer

Specifications are subject to change without notice. “Typical” parameters are the average values expected by Cree in large quantities and are provided for information purposes only. Cree products are not warranted or authorized for use as critical components in medical, life-saving, or life-sustaining applications, or other applications where a failure would reasonably be expected to cause severe personal injury or death. No responsibility is assumed by Cree for any infringement of patents or other rights of third parties which may result from use of the information contained herein. No license is granted by implication or otherwise under any patent or patent rights of Cree.