

PART NUMBER	SML-LXT0805SUGW-TR	REV.	D
DATE	E.C.N. NUMBER AND REVISION COMMENTS	REV.	
03.22.04	E.C.N. #10967.	A	
08.12.05	E.C.N. #11248.	B	
09.30.09	E.C.N. #11508.	C	
09.30.09	ECN-Lumex201900133	D	

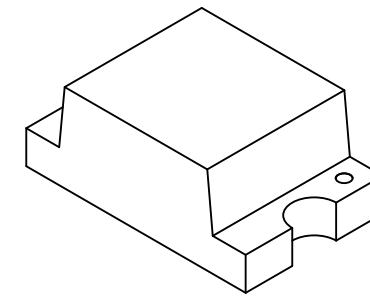

ELECTRO-OPTICAL CHARACTERISTICS $T_A=25^\circ\text{C}$ $I_f=20\text{mA}$					
PARAMETER	MIN	TYP	MAX	UNITS	TEST COND
PEAK WAVELENGTH		574		nm	
[P3] FORWARD VOLTAGE		2.2	2.6	V_f	
REVERSE VOLTAGE	5.0			V_r	$I_f=100\mu\text{A}$
AXIAL INTENSITY	25	40		mcd	$I_f=20\text{mA}$
VIEWING ANGLE		140		2x theta	
[V3] EMITTED COLOR:	GREEN				
[V3] EPOXY LENS FINISH:	MILKY WHITE DIFFUSED				

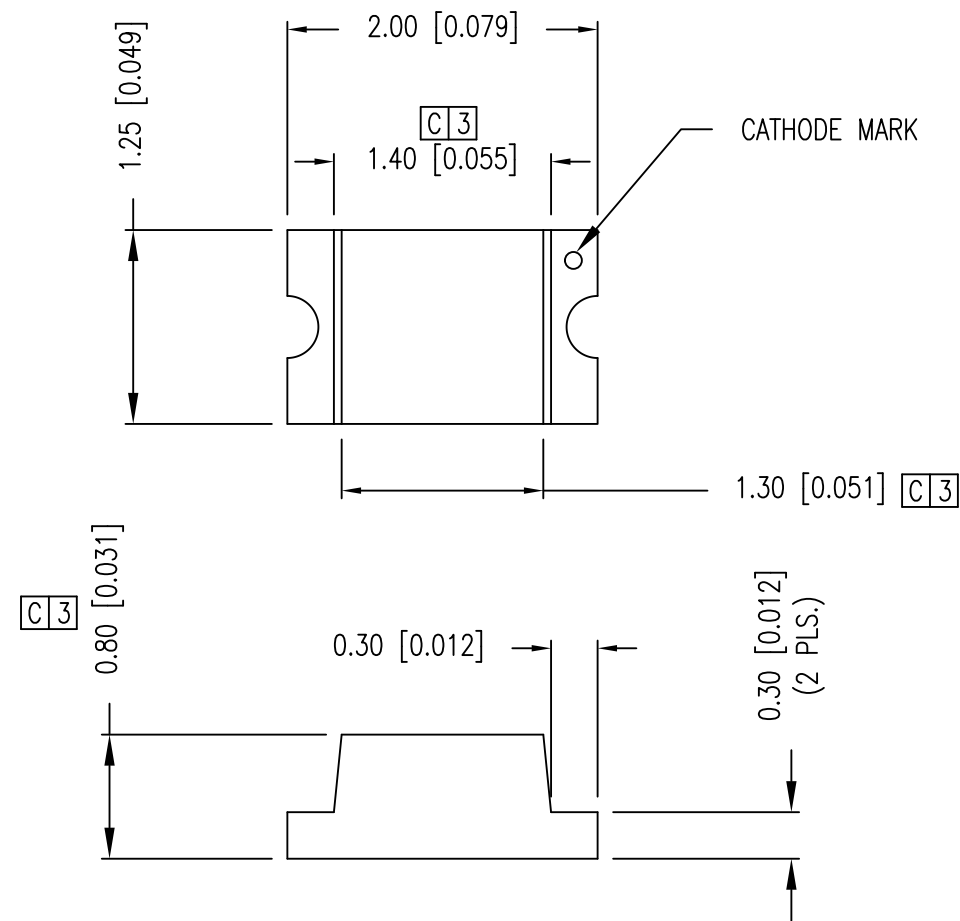
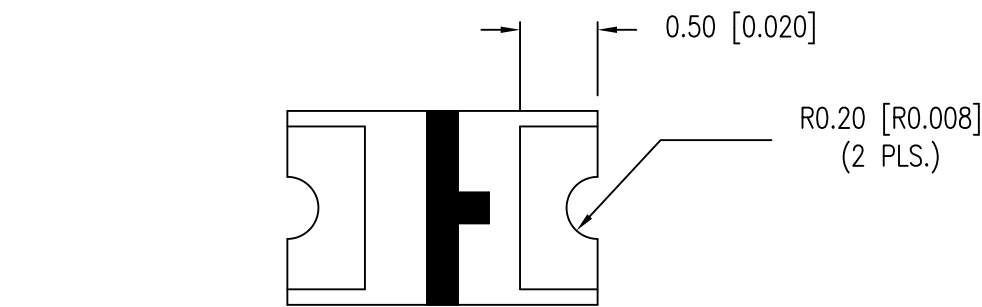

[B] LEAD FREE REFLOW PROFILE

10 SEC. MAX.

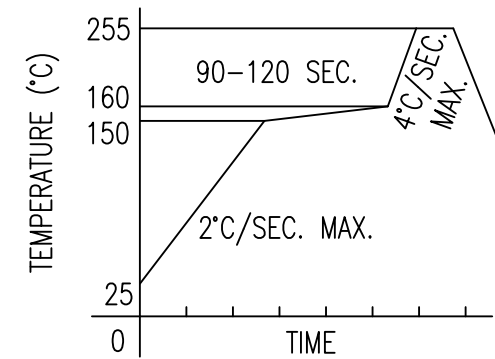

TOTAL TIME ABOVE 220°C IS 60 SECONDS MAX.

LIMITS OF SAFE OPERATION AT 25°C		
PARAMETER	MAX	UNITS
PEAK FORWARD CURRENT*	100	mA
STEADY CURRENT	30	mA
POWER DISSIPATION	50	mW
DERATE FROM 25°C	-1.2	mW/°C
OPERATING TEMP.	-25 TO +80	°C
STORAGE TEMP.	-30 TO +85	°C

* $t < 10\mu\text{s}$

- NOTES:
- 4K PER REEL
 - CATHODE IS ORIENTED TOWARDS THE TAPE SPROCKET HOLE.

[D][C][A] CAUTION: MOISTURE SENSITIVE DEVICE PER JEDEC LEVEL 2a STANDARDS

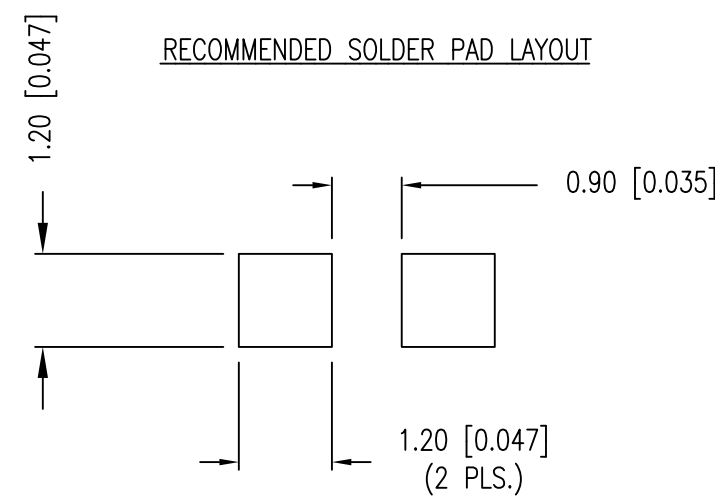
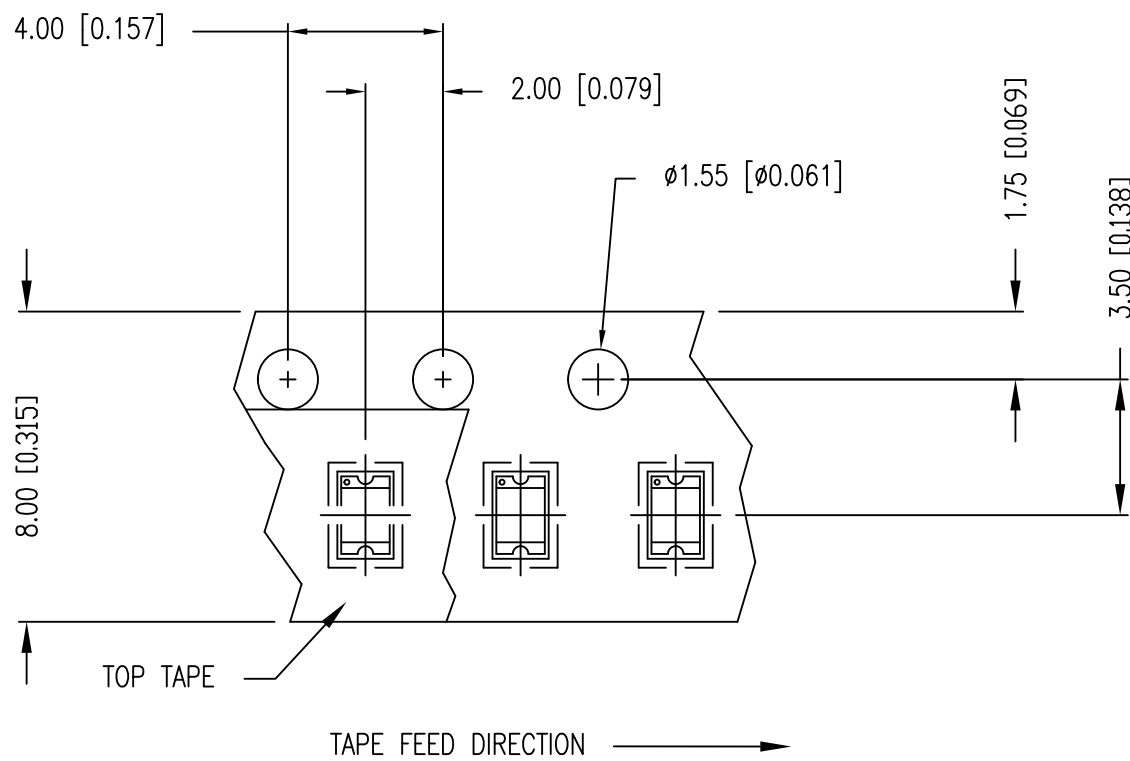

[C][M] [C3] [C3]

*UNLESS OTHERWISE SPECIFIED TOLERANCES PER DECIMAL PRECISION ARE: X=±1 (±0.039), X.X=±0.5 (±0.020), X.XX=±0.25 (±0.010), X.XXX=±0.127 (±0.005). LEAD SIZE=±0.05 (±0.002), LEAD LENGTH=±0.75 (±0.030). MIN= +DECIMAL PRECISION -0.00, MAX.= +0.00 -DECIMAL PRECISION UNCONTROLLED DOCUMENT



425 N. GARY AVE.
CAROL STREAM, IL 60188
PHONE: 800-278-5666
FAX: 630-315-2150
WEB: WWW.LUMEX.COM

2.0mm x 1.25mm THIN PCB SURFACE MOUNT, 574nm AlInGaP GREEN LED, MILKY WHITE DIFFUSED, TAPE & REEL.

THE SPECIFICATIONS MAY CHANGE AT ANY TIME WITHOUT NOTICE

CONFIDENTIAL INFORMATION
THE INFORMATION CONTAINED IN THIS DOCUMENT IS THE PROPERTY OF LUMEX INC. EXCEPT AS SPECIFICALLY AUTHORIZED IN WRITING BY LUMEX INC., THE HOLDER OF THIS DOCUMENT SHALL KEEP ALL INFORMATION CONTAINED HEREIN CONFIDENTIAL AND SHALL PROTECT SAME IN WHOLE OR IN PART FROM DISCLOSURE AND DISSEMINATION TO ALL THIRD PARTIES.

DATE:	12.17.19	DRAWN BY:	C.S.
PAGE:	1 OF 1	CHKD BY:	E.C.
SCALE:	N/A	APRVD BY:	G.Y.
UNIT:	mm [INCH]		(Rb)