

LOOSE PIECE		TAPE MOUNTED		SPECIFICATIONS						
MATERIAL NUMBER	ENGINEERING NUMBER	MATERIAL NUMBER	ENGINEERING NUMBER	STUD SIZE	"S" ±.005 [0.13]	"W" ±.010 [0.25]	"C" MIN.	"L" MAX.	"H"	STOCK ±.001 [0.025] THICKNESS
190570046	B-518-38	---	---	38	.390 [9.91]	.534 [13.56]	.554 [14.07]	1.407 [35.74]	---	.031 [0.79]
190570048	B-518-56	---	---	56	.328 [8.33]					
190570052	B-523-04	---	---	4	.119 [3.02]	.250 [6.35]	.209 [5.31]	.931 [23.65]	.980 [24.89]	.031 [0.79]
190570054	B-523-06	190570055	B-523-06T	6	.146 [3.71]					
190570056	B-523-08	190570057	B-523-08T	8	.173 [4.39]					
190570060	B-525-14	---	---	14	.265 [6.73]	.467 [11.86]	.388 [9.86]	1.208 [30.68]	---	.031 [0.79]
190570062	B-525-56	---	---	56	.328 [8.33]					
190570086	B-537-04	---	---	4	.119 [3.02]	.312 [7.92]	.285 [7.24]	1.022 [25.96]	---	.031 [0.79]
190570088	B-537-06	---	---	6	.146 [3.71]					
190570090	B-537-08	---	---	8	.173 [4.39]					
190570093	B-537-10	---	---	10	.198 [5.03]					
190570100	B-539-08	---	---	8	.173 [4.39]	.342 [8.69]	.310 [7.87]	1.067 [27.10]	---	.031 [0.79]
190570102	B-539-10	---	---	10	.198 [5.03]					

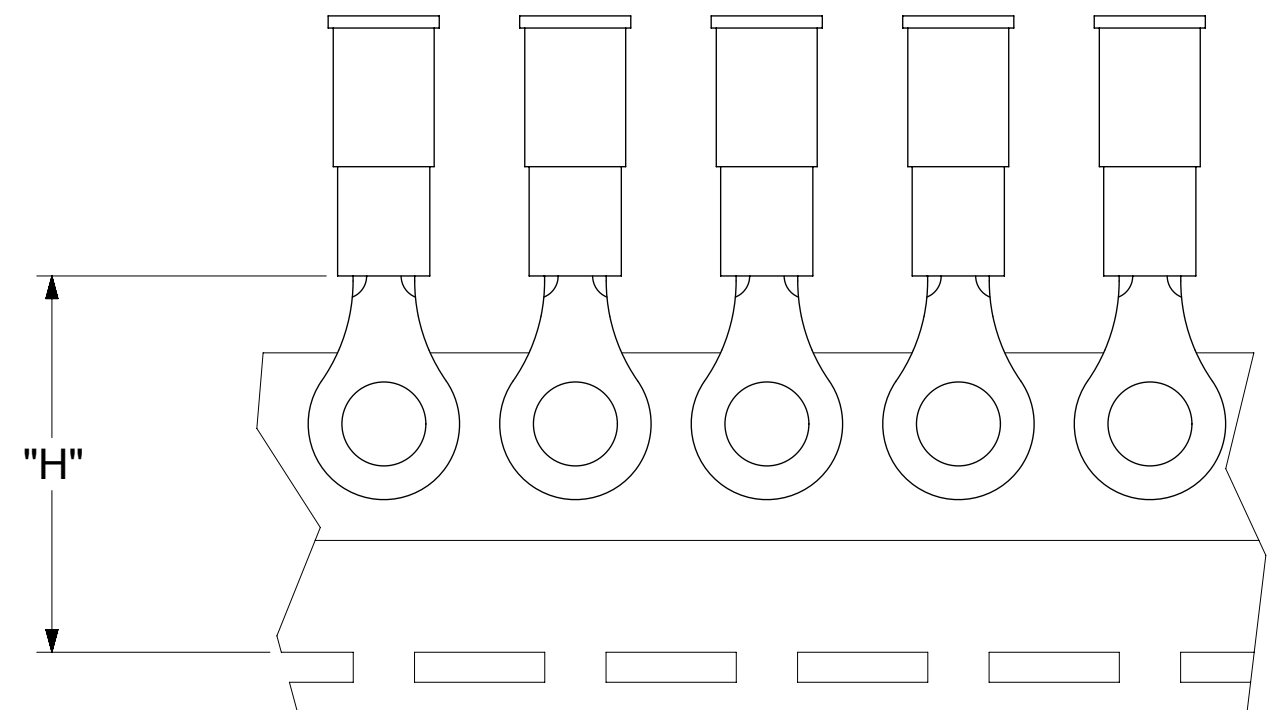
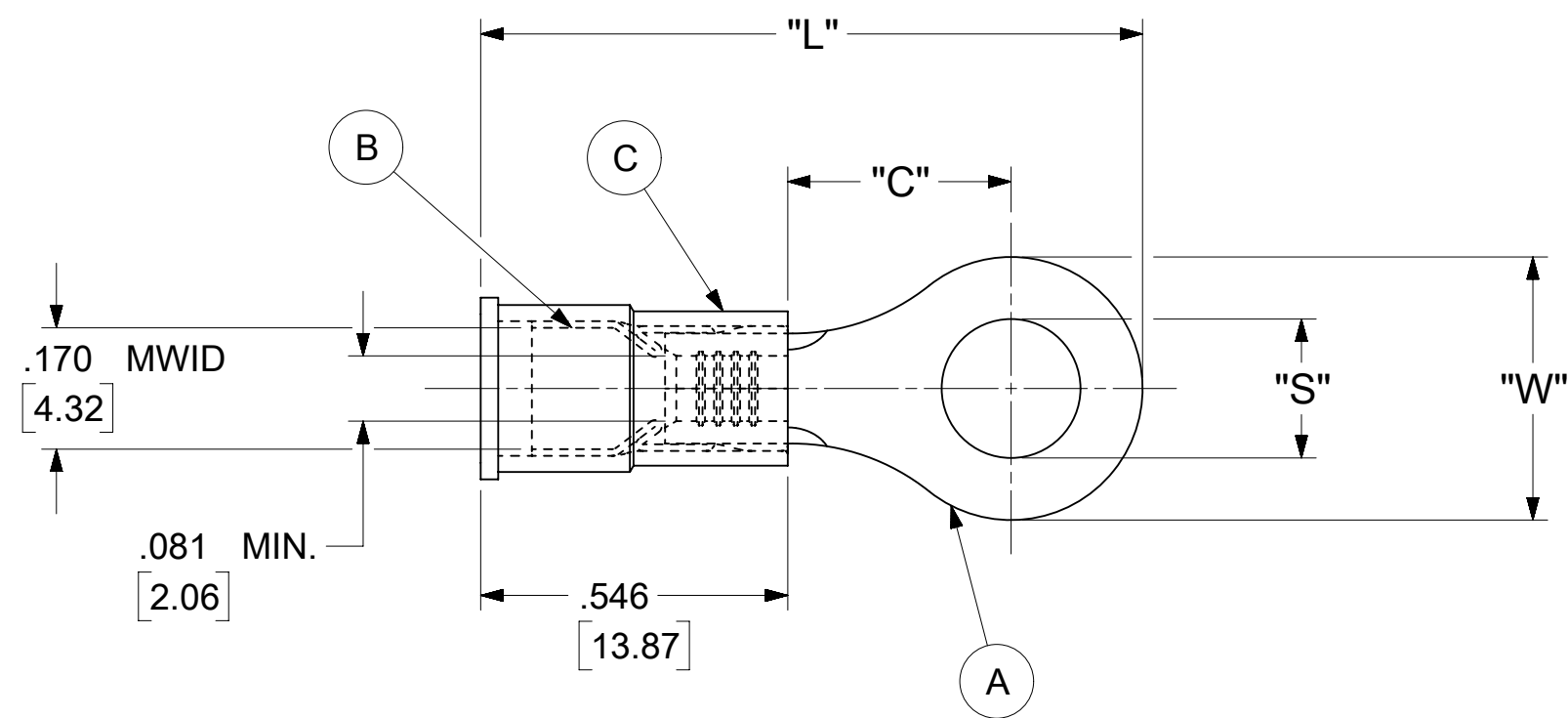

PARTS ON TAPE

NOTES:

- MATERIAL:
 - (A). RING TONGUE TERMINAL: COPPER
PLATING: ELECTRO-TIN (.0003 MIN.)
 - (B). TIN-PLATED BRASS FUNNEL FERRULE
 - (C). INSULATION: NYLON (BLUE)
- MWID: MAXIMUM WIRE INSULATION DIAMETER
- WIRE SIZE: 16 -14 AWG
1.0 -2.5 MM²
- ALL DIMENSIONS IN INCHES/[MM].
- PARTS ARE ROHS COMPLIANT.
- DIMS. SHOWN ARE FOR REFERENCE ONLY.

SYMBOLS	THIS DRAWING CONTAINS INFORMATION THAT IS PROPRIETARY TO MOLEX ELECTRONIC TECHNOLOGIES, LLC AND SHOULD NOT BE USED WITHOUT WRITTEN PERMISSION									
	DIMENSION UNITS		SCALE		CURRENT REV DESC: MIGRATION TO ECTR/NX					
▽ = 0	INCH/MM		NTS		EC NO: 620952 DRWN: ABENJAMINLW 2019/06/14 CHK'D: GROJAS01 2019/07/19 APPR: JMACNEIL 2019/08/05 INITIAL REVISION: DRWN: KO 1984/11/12 APPR: JMACNEIL 2019/08/05					
▽ = 0	GENERAL TOLERANCES (UNLESS SPECIFIED)									
▽ = 0			MM	INCH	PRODUCT CUSTOMER DRAWING DOCUMENT NUMBER: 190570042 DOC TYPE: PSD DOC PART: 000 REVISION: A MATERIAL NUMBER: SEE TABLE CUSTOMER: GENERAL MARKET SHEET NUMBER: 1 OF 1					
▽ = 0	4 PLACES	±	---	±						
▽ = 0	3 PLACES	±	---	±	.005					
▽ = 0	2 PLACES	±	0.13	±	.01					
▽ = 0	1 PLACE	±	0.25	±	---					
▽ = 0	0 PLACES	±	---	±	---					
▽ = 0	ANGULAR TOL		± 0.5 °							
▽ = 0	DRAFT WHERE APPLICABLE MUST REMAIN WITHIN DIMENSIONS				THIRD ANGLE PROJECTION		DRAWING		SERIES	
▽ = 0					C-SIZE		19057			

NOTES:

- ① MAT'L: COPPER (STOCK TKN. $\frac{.031}{.79}$) $\pm .001$
- PLATING: ELECTRO TIN (.0003 MIN)
- ② TIN-PLATED BRASS FUNNEL FERRULE
- ③ NYLON INSULATION (COLOR CODED BLUE)

FILE NO. B-CD-501-01

STUD SIZES: ($\pm .005$)

- 02 = .094
- 04 = .119
- 06 = .146
- 08 = .173
- 10 = .198
- 14 = .265
- 56 = .328
- 38 = .390

"UL" LISTING # E32244
 "CSA" LISTING # 18689

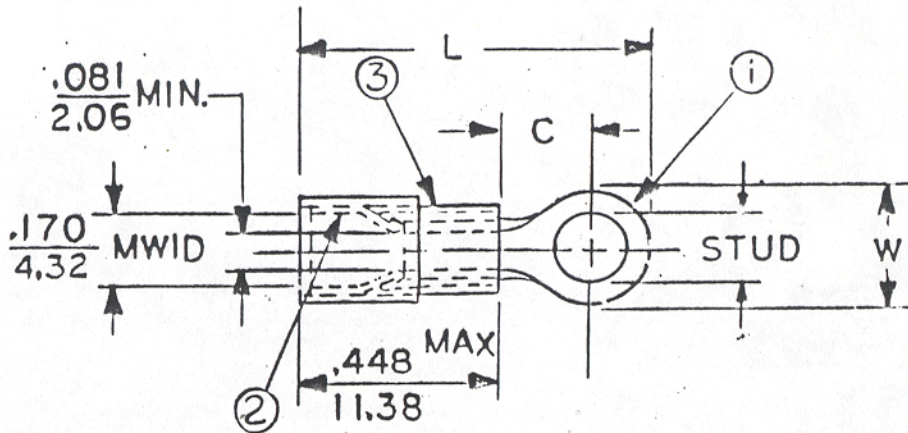

WIRE SIZE: 16-14 AWG
 1.0-2.5 MM²

ALL DIMENSIONS = $\frac{\text{INCHES}}{\text{MM}}$ (MWID) = DENOTES MAXIMUM WIRE INSULATION DIAMETER

PART NUMBER	"W" $\pm .010$	"C" MIN.	"L" MAX.				AVAILABLE STUD SIZES
B-523-	$\frac{.250}{6.35}$	$\frac{.209}{5.31}$	$\frac{.833}{21.16}$				02, 04, 06, 08

DIMENSIONAL TOLERANCES UNLESS OTHERWISE SPECIFIED			REFERENCE	SCALE: NTS	DATE	TITLE: RING TONGUE TERMINAL AVIKRIMP 500-SERIES		
FRAC.	DEC.	ANG.		DRWN. BY: <i>fo</i>	11-12-84			
\pm	\pm	\pm		CHKD. BY: <i>6Z</i>	11-30-84			
				APPRD. BY:				
							DWG. NO. A	CUSTOMER DWG