

LOOSE PIECE		TAPE MOUNTED		SPECIFICATIONS						
MATERIAL NUMBER	ALTERNATE NUMBER	MATERIAL NUMBER	ALTERNATE NUMBER	STUD SIZE	'S" ±.005/(0.13)	'W" ±.010/(0.25)	'C" MIN.	'L" MAX.	'ID" MIN.	STOCK THICKNESS
190440063	A-120-02	-	-	2	.094/(2.39)	.225/(5.72)	.157/(3.99)	.563/(14.30)	.062/(1.57)	.028/1.71)
190440064	A-120-04	-	-	4	.119/(3.02)	.225/(5.72)	.157/(3.99)	.563/(14.30)	.062/(1.57)	.028/1.71)
190440066	A-120-06	-	-	6	.146/(3.71)	.225/(5.72)	.157/(3.99)	.563/(14.30)	.062/(1.57)	.028/1.71)
190440068	A-121-06	-	-	6	.146/(3.71)	.312/(7.92)	.270/(6.86)	.720/(18.29)	.062/(1.57)	.028/1.71)
190440069	A-121-08	-	-	8	.173/(4.39)	.312/(7.92)	.270/(6.86)	.720/(18.29)	.062/(1.57)	.028/1.71)
190440072	A-121-10	190440073	A-121-10T	10	.198/(5.03)	.312/(7.92)	.270/(6.86)	.720/(18.29)	.062/(1.57)	.028/1.71)
190440075	A-122-14	-	-	1/4	.265/(6.73)	.467/(11.86)	.386/(9.80)	.914/(23.22)	.062/(1.57)	.028/1.71)
190440077	A-122-56	-	-	5/16	.328/(8.33)	.467/(11.86)	.386/(9.80)	.914/(23.22)	.062/(1.57)	.028/1.71)
190440078	A-126-10	-	-	10	.198/(5.03)	.534/(13.56)	.552/(14.02)	1.113/(28.27)	.054/(1.37)	.031/1.79)
190440079	A-126-14	-	-	1/4	.265/(6.73)	.534/(13.56)	.552/(14.02)	1.113/(28.27)	.054/(1.37)	.031/1.79)
190440082	A-126-56	-	-	5/16	.328/(8.33)	.534/(13.56)	.552/(14.02)	1.113/(28.27)	.054/(1.37)	.031/1.79)
190440081	A-126-38	-	-	3/8	.390/(9.91)	.534/(13.56)	.552/(14.02)	1.113/(28.27)	.054/(1.37)	.031/1.79)
190440083	A-132-04	-	-	4	.126/(3.20)	.256/(6.45)	.240/(6.10)	.661/(16.69)	.062/(1.57)	.028/1.71)
190440084	A-132-06	-	-	6	.146/(3.71)	.256/(6.45)	.240/(6.10)	.661/(16.69)	.062/(1.57)	.028/1.71)
190440086	A-132-08	-	-	8	.146/(3.71)	.256/(6.45)	.240/(6.10)	.661/(16.69)	.062/(1.57)	.028/1.71)

(C3)

(C3)

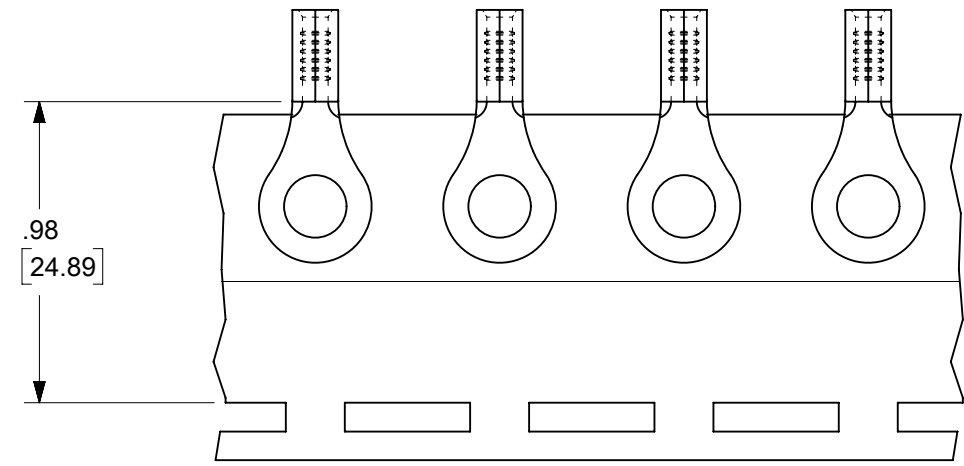
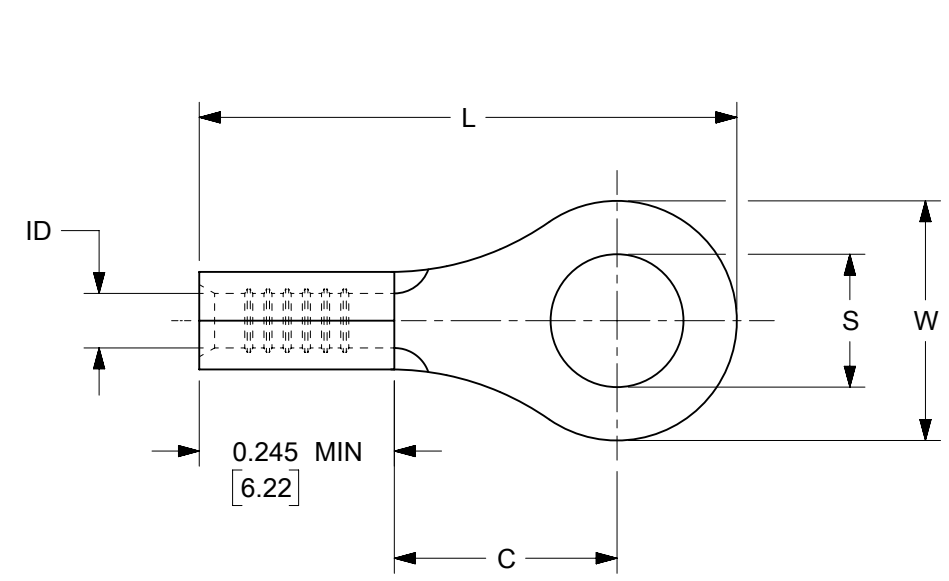

SEE TABLE FOR TAPE MOUNTED PARTS

- 1. MATERIAL : COPPER
- 2. PLATING : ELECTRO-TIN
- 3. PARTS ARE RoHS COMPLIANT.

THIS DRAWING CONTAINS INFORMATION THAT IS PROPRIETARY TO MOLEX ELECTRONIC TECHNOLOGIES, LLC AND SHOULD NOT BE USED WITHOUT WRITTEN PERMISSION											
DIMENSION UNITS INCH/MM		SCALE NTS		CURRENT REV DESC: REMASTERED IN NX AND REVISED							
GENERAL TOLERANCES (UNLESS SPECIFIED)				EC NO: 676039		2021/08/23		RING TONGUE			
				DRWN: SCV		2021/08/31		PRODUCT CUSTOMER DRAWING			
				CHK'D: DMYRICK		2021/08/31		DOCUMENT NUMBER			
				APPR: EJOHNSON04		2021/08/31		SD-19044-001			
				INITIAL REVISION:		1999/10/27		DOC TYPE		DOC PART	
				DRWN: HEB		1999/10/27		PSD		001	
				APPR: RWD		1999/10/27		REVISION		C3	
DRAFT WHERE APPLICABLE MUST REMAIN WITHIN DIMENSIONS				THIRD ANGLE PROJECTION		DRAWING		SERIES		SHEET NUMBER	
				B-SIZE		19044		MATERIAL NUMBER		CUSTOMER	
				SEE TABLE		GENERAL MARKET				1 OF 1	