

SERIES: ACZ09 | **DESCRIPTION:** MECHANICAL INCREMENTAL ENCODER**ELECTRICAL SPECIFICATIONS**

parameter	conditions/description
output waveform	square wave
output signals	A, B phase
current consumption	10 mA
output phase difference	T1, T2, T3, T4 \geq 3.5 ms @ 60 rpm
supply voltage	5 V dc max.
output resolution	10, 15, 20 ppr
switch rating	12 V dc, 50 mA (ACZ09BRXE models only)
insulation resistance	100 M Ω , 300 V dc, 1 min.
withstand voltage	300 V ac, 1 minute; no arc, damage or dielectric breakdown

MECHANICAL SPECIFICATIONS

parameter	conditions/description	min	nom	max	units
shaft load	axial			8	kgf
rotational torque	with detent click	60	140	220	gf•cm
	without detent click	60	80	100	gf•cm
push switch operational force	(ACZ09BRXE models only)	300		1,500	gf•cm
push switch life	(ACZ09BRXE models only)			50,000	cycles
rotational life				30,000	cycles

ENVIRONMENTAL SPECIFICATIONS

parameter	conditions/description	min	nom	max	units
operating temperature		-10		75	°C
storage temperature		-20		75	°C
humidity		0		95	% RH
vibration	0.75 mm max. travel for 2 hours	10		55	Hz

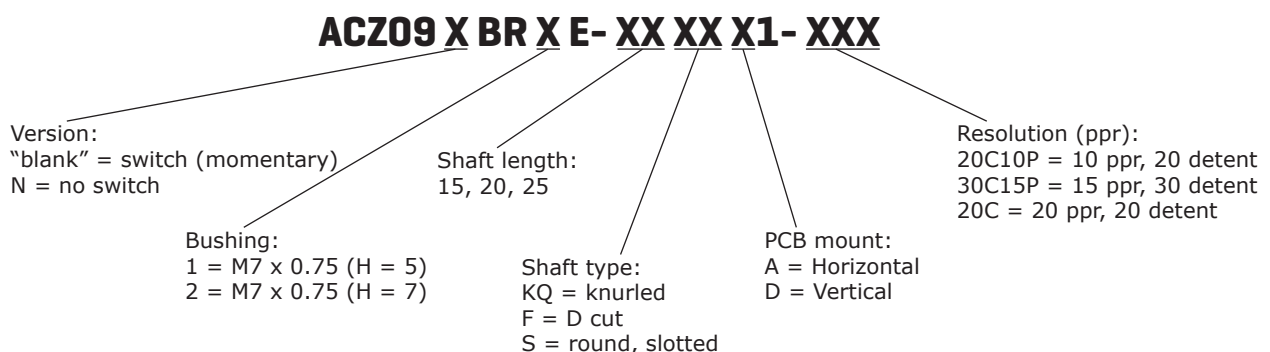
PART NUMBER KEY

SHAFT OPTIONS (VERSIONS WITH SWITCH)

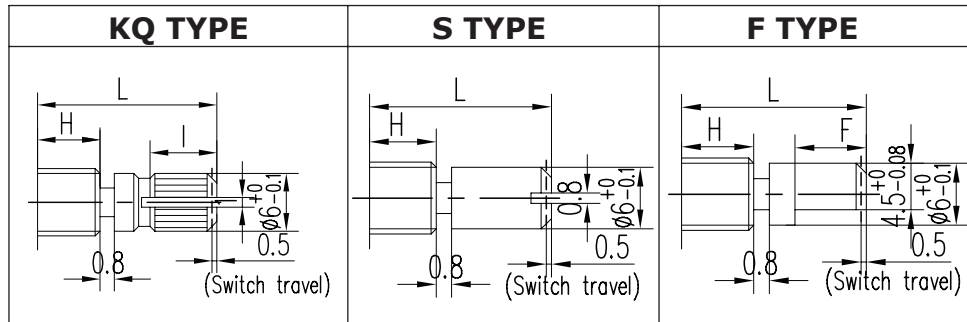

H=5

	15KQ	20KQ	25KQ
L	15	20	25
I	7	8.5	12

H=5

	15S	20S	25S
L	15	20	25

H=5

	15F	20F	25F
L	15	20	25
F	8	12	12

H=7

	15KQ	20KQ	25KQ
L	15	20	25
I	5	8.5	10

H=7

	15F	20F	25F
L	15	20	25
F	5	8.5	10

SHAFT OPTIONS (VERSIONS WITHOUT SWITCH)

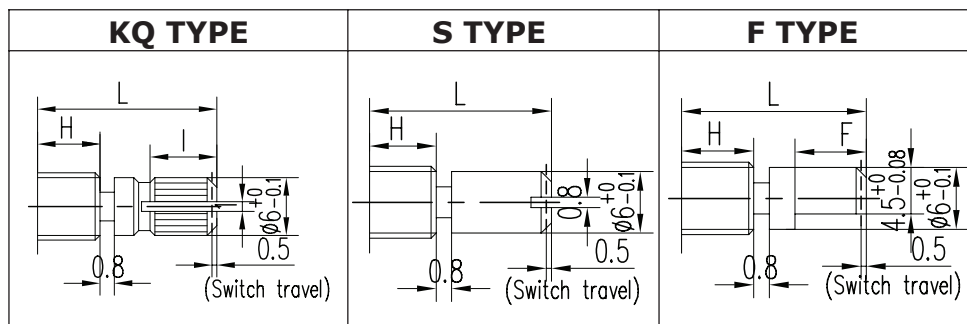

H=5

L	15	20	25	30
I	6	8.5	12	12

H=5/7

L	15	20	25	30
---	----	----	----	----

H=5

L	15	20	25	30
F	8	12	12	12

H=7

L	15	20	25	30
I	5	8.5	10	10

H=7

L	15	20	25	30
F	5	12	12	12

MECHANICAL DRAWING (horizontal)

ACZ09NBRXE

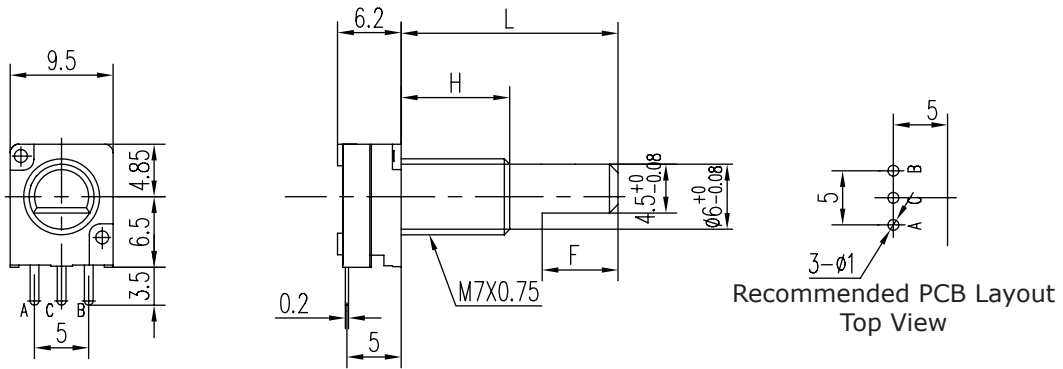

ACZ09BRXE

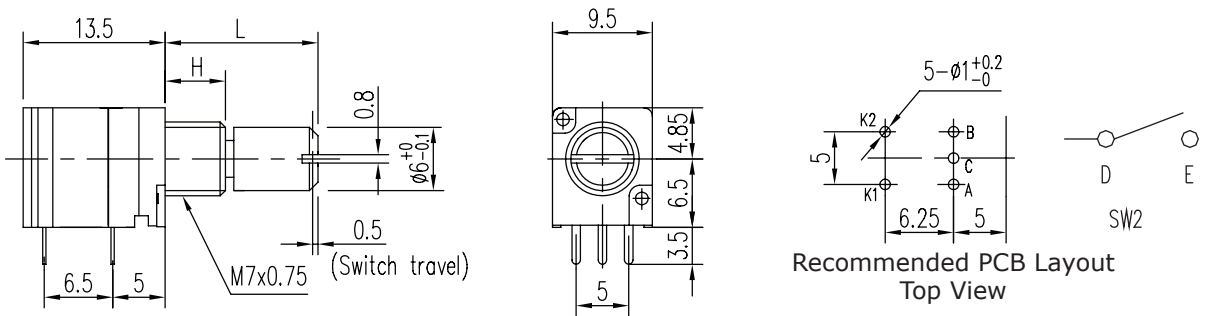

MECHANICAL DRAWING (vertical)

ACZ09NBRXE

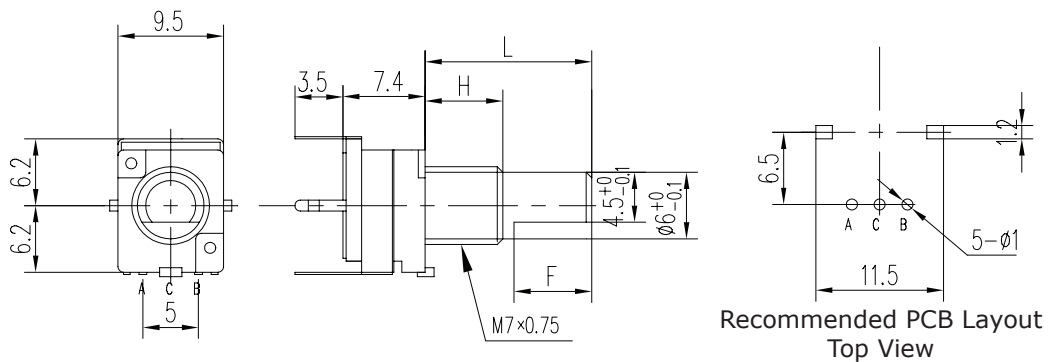

ACZ09BRXE

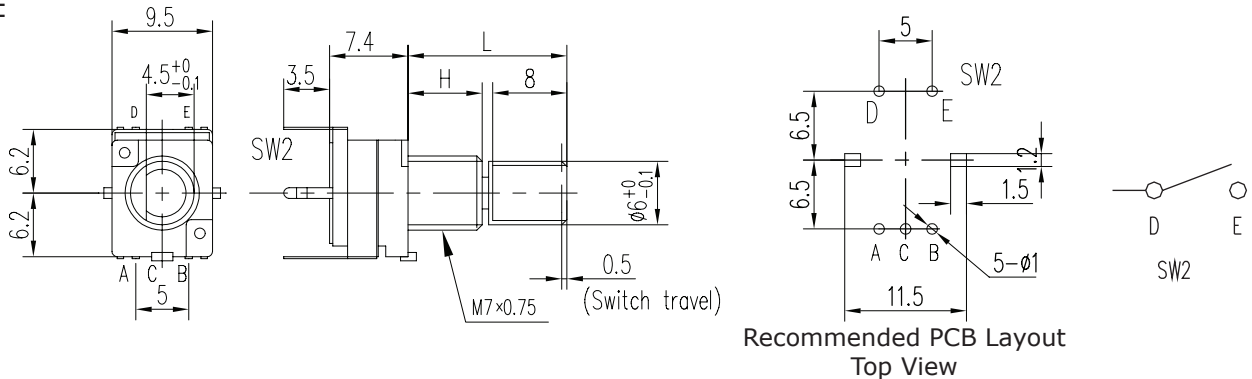

REVISION HISTORY

rev.	description	date
1.0	initial release	10/30/2009
1.01	brand update	10/04/2019
1.02	updated datasheet	06/15/2020
1.03	updated datasheet	08/10/2021

The revision history provided is for informational purposes only and is believed to be accurate.

CUI DEVICES

CUI Devices offers a one (1) year limited warranty. Complete warranty information is listed on our website.

CUI Devices reserves the right to make changes to the product at any time without notice. Information provided by CUI Devices is believed to be accurate and reliable. However, no responsibility is assumed by CUI Devices for its use, nor for any infringements of patents or other rights of third parties which may result from its use.

CUI Devices products are not authorized or warranted for use as critical components in equipment that requires an extremely high level of reliability. A critical component is any component of a life support device or system whose failure to perform can be reasonably expected to cause the failure of the life support device or system, or to affect its safety or effectiveness.