

REV.	DESCRIPTION	DATE	APPROVED
A	Engineering Release	06/30/14	J. C.
B	Revised Typo	04/01/15	J. C.
C	Engineering Update w/o Changes	05/25/16	J. C.

SERIES P/N	"H" IN (MM)	"B" IN (MM)
MSB3.0-04SP	0.157 (4)	0.12 (3)
MSB3.0-05SP	0.197 (5)	0.16 (4)
MSB3.0-06SP	0.236 (6)	0.20 (5)
MSB3.0-07SP	0.276 (7)	0.23 (5)
MSB3.0-08SP	0.315 (8)	0.24 (6) MIN.
MSB3.0-09SP	0.354 (9)	0.24 (6) MIN.
MSB3.0-10SP	0.394 (10)	0.24 (6) MIN.
MSB3.0-11SP	0.433 (11)	0.24 (6) MIN.
MSB3.0-12SP	0.472 (12)	0.24 (6) MIN.
MSB3.0-13SP	0.512 (13)	0.24 (6) MIN.
MSB3.0-14SP	0.551 (14)	0.24 (6) MIN.
MSB3.0-15SP	0.591 (15)	0.24 (6) MIN.
MSB3.0-16SP	0.630 (16)	0.24 (6) MIN.
MSB3.0-17SP	0.669 (17)	0.24 (6) MIN.
MSB3.0-18SP	0.709 (18)	0.24 (6) MIN.
MSB3.0-19SP	0.748 (19)	0.24 (6) MIN.
MSB3.0-20SP	0.787 (20)	0.24 (6) MIN.
MSB3.0-21SP	0.827 (21)	0.24 (6) MIN.
MSB3.0-22SP	0.866 (22)	0.24 (6) MIN.
MSB3.0-25SP	0.984 (25)	0.24 (6) MIN.
MSB3.0-27SP	1.063 (27)	0.24 (6) MIN.
MSB3.0-28SP	1.102 (28)	0.24 (6) MIN.
MSB3.0-29SP	1.141 (29)	0.24 (6) MIN.
MSB3.0-30SP	1.181 (30)	0.24 (6) MIN.

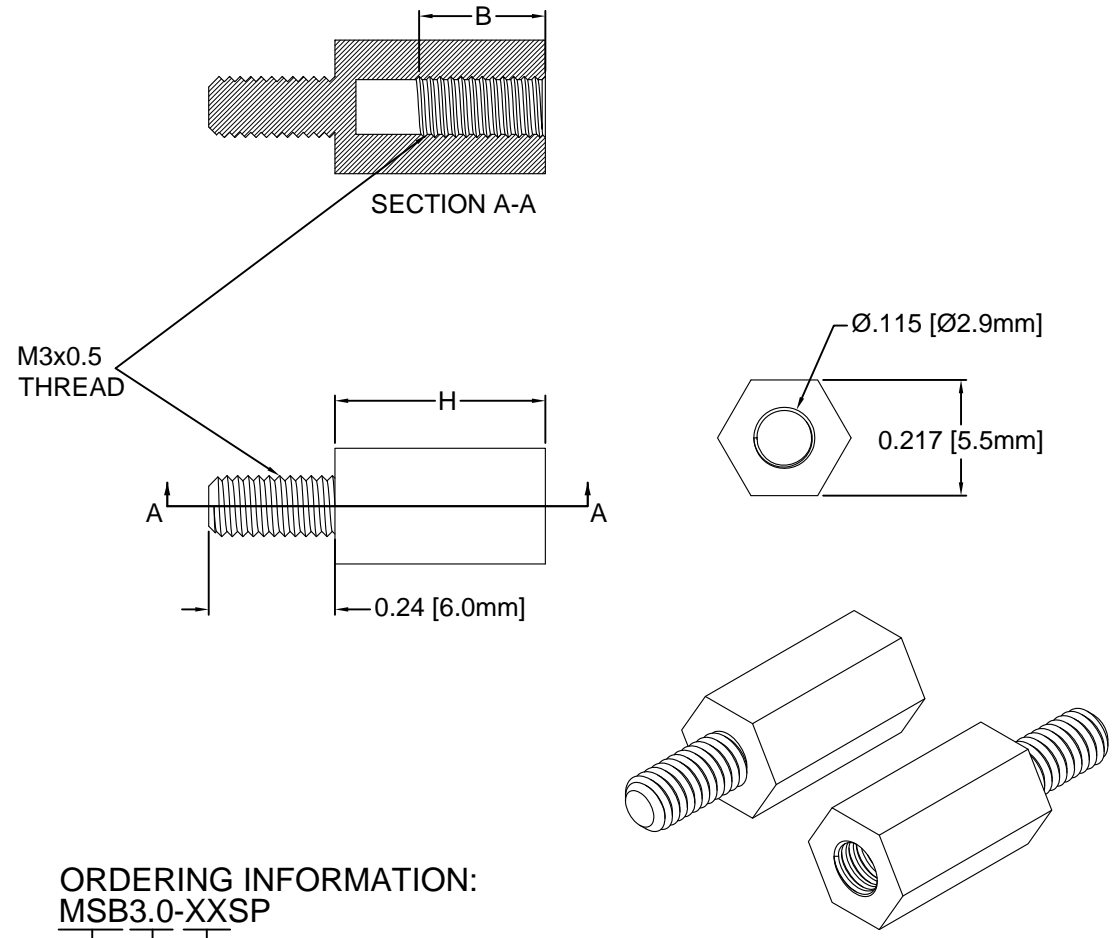

ORDERING INFORMATION:
MSB3.0-XXSP

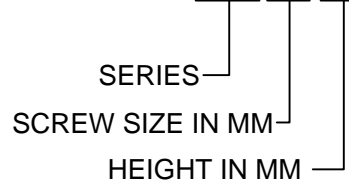

2. TOLERANCE "H" DIMENSION:
0.197 - 0.786 (5.0 - 19.9mm)±0.012(0.3mm)
0.787 - 1.575 (20.0 - 40.0mm)±0.016(0.4mm)
1. MATERIAL: NYLON 6/6, UL 94V-2, NATURAL.

STANDARD TOLERANCE (UNLESS OTHERWISE SPECIFIED)		 4 THOMAS, IRVINE, CA. 92618 TEL: (949) 951-8808 FAX: (949) 951-3974	
DECIMALS	ANGULAR		
.X ±.1	X° ± 1°		TITLE: M3 BOARD-TO-BOARD SPACER
.XX ±.01			PART NO: MSB3.0-XXSP
.XXX ±.005		DESIGNED: A. Wright	REVISION: C
		CHECKED: B. Oliver	CAGE CODE : 32559 SHEET # 1 OF 1
			CAD GENERATED DOCUMENT. DO NOT MEASURE DRAWING.