

FCM400 Series



- Integral Low Noise Fan
- 400 W Output Power
- 600 W Peak Rating 500 ms
- Screw Terminals
- Class B Conducted Emissions
- 5 V Standby Rail
- 80 V – 275 VAC Input Operation
- IT & Medical Safety Approvals
- Remote On/Off & Power Fail Signal as Standard

The FCM400 AC-DC power supply provides upto 400 W continuous and 600 W peak output power for up to 0.5 seconds.

Packaged in a compact 6" (152 mm) x 4" (102 mm) x 1.9" (49 mm) and certified to IEC60950, IEC6238 & IEC60601 family safety approvals, the FCM400 can be easily integrated into a wide range of both industrial and medical applications. A low noise fan allows quiet operation at full power from -10 °C to 50 °C and 50% power at +70 °C.

The unit comprises of a main output with voltages from 12-48 VDC and a peripheral output providing a 5 VDC standby supply which can be utilised with the signals and control features of the unit to provide detection of loss of AC input and remote on/off control.

Models and Ratings

Output Power		Output Voltage V1	Output Current V1		Standby Supply V2	Model Number
P nom	P peak ⁽¹⁾		I nom	I peak ⁽¹⁾		
400 W	600 W	12.0 VDC	33.3 A	50 A	5.0 V/0.5 A	FCM400PS12
400 W	600 W	15.0 VDC	26.6 A	40 A	5.0 V/0.5 A	FCM400PS15
400 W	600 W	24.0 VDC	16.6 A	25 A	5.0 V/0.5 A	FCM400PS24
400 W	600 W	28.0 VDC	14.2 A	21.4 A	5.0 V/0.5 A	FCM400PS28
400 W	600 W	36.0 VDC	11.1 A	16.7 A	5.0 V/0.5 A	FCM400PS36
400 W	600 W	48.0 VDC	8.3 A	12.5 A	5.0 V/0.5 A	FCM400PS48

Notes:

1. Peak duration is 500 ms max, average power must not exceed 400 W.

Input Characteristics

Characteristic	Minimum	Typical	Maximum	Units	Notes & Conditions
Input Voltage - Operating	80	115/230	275	VAC	Derate output power <90 VAC. See fig 1. Power fail signal cannot be used <90 VAC.
Input Frequency	47	50/60	63	Hz	
Power Factor		>0.9			EN61000-3-2 class A compliant
Input Current - No Load		0.11/0.15		A	115/230 VAC
Input Current - Full Load		4.1/2.1		A	115/230 VAC
Inrush Current			60	A	230 VAC, 25°C
Earth Leakage Current		100/165	260	µA	115 VAC 60 Hz/230 VAC 50 Hz (Typ), 264 VAC/60 Hz (Max.)
Input Protection	F10 A/250 V internal fuse in both line and neutral				

Output Characteristics

Characteristic	Minimum	Typical	Maximum	Units	Notes & Conditions
Output Voltage - V1	12		48	VDC	See Models and Ratings table
Initial Set Accuracy			±0.5 ^(v1) , ±5 ^(v2)	%	50% load, 115/230 VAC
Output Voltage Adjustment	±10			%	V1 only via potentiometer. See mech. details (page 11).
Minimum Load	0			A	
Start Up Delay		1		s	230 VAC full load (see fig.2)
Hold Up Time	20	35		ms	90 VAC full load (see fig.3)
Drift			±0.2	%	After 20 min warm up
Line Regulation			±0.5	%	90-264 VAC
Load Regulation			±1 ^(v1) , ±5 ^(v2)	%	0-100% load.
Transient Response - V1			4	%	Recovery within 1% in less than 500 µs for a 50-75% and 75-50% load step
Over/Undershoot - V1			5	%	
Ripple & Noise		0.5	1 ^(v1) , 2 ^(v2)	% pk-pk	20 MHz bandwidth (see fig.4 & 5)
Overvoltage Protection	115		140	%	Vnom DC. Output 1 only, recycle input to reset
Overload Protection	150		165	% I nom	Output 1 only, auto reset (see fig.6)
Short Circuit Protection					Continuous (see fig. 6)
Temperature Coefficient			0.05	%/°C	
Overtemperature Protection				°C	Auto recovery - temperature of main transformer

Input Voltage Derating

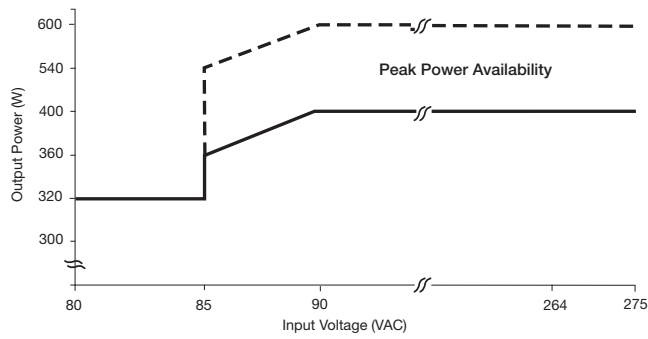

Figure. 1

Start Up Delay From AC Turn On

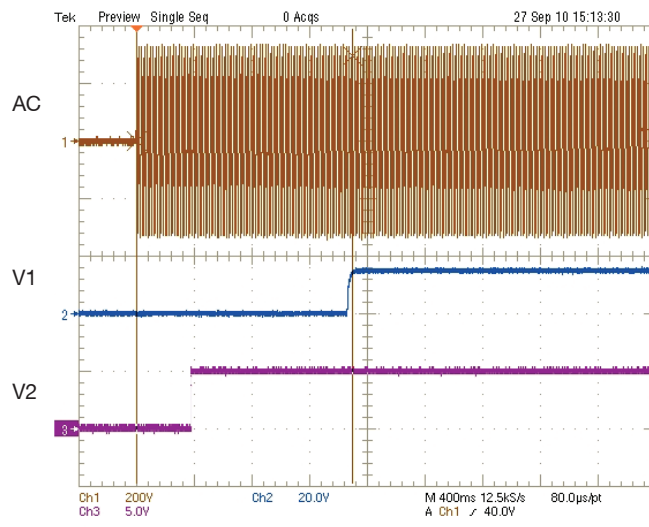

Figure. 2
V1 & V2 start up example from AC turn on (1.5 s)

Hold Up Time From Loss of AC

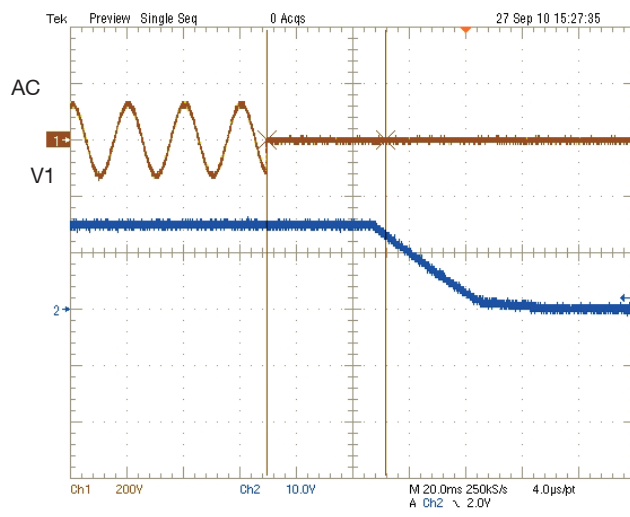

Figure 3
V1 hold up example at 400 W load with 90 VAC input (42 ms)

Output Ripple & Noise

Figure 4
V1 FCM400PS12 (full load)
50 mV pk-pk ripple. 20 MHz BW

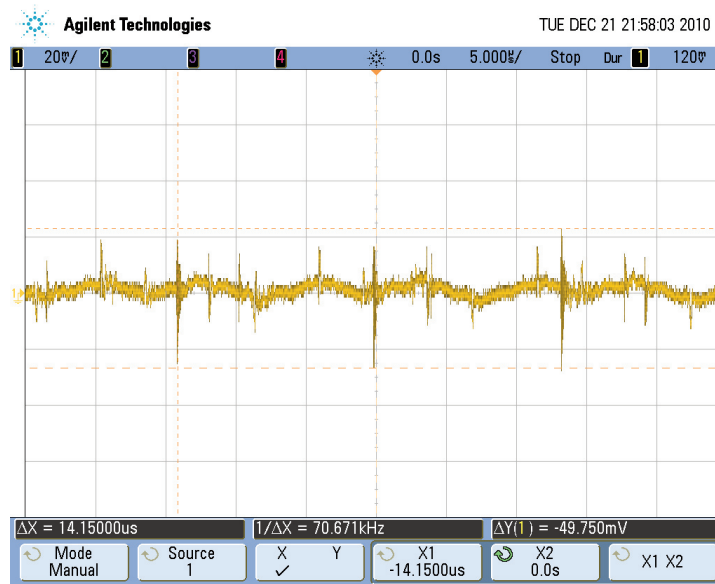
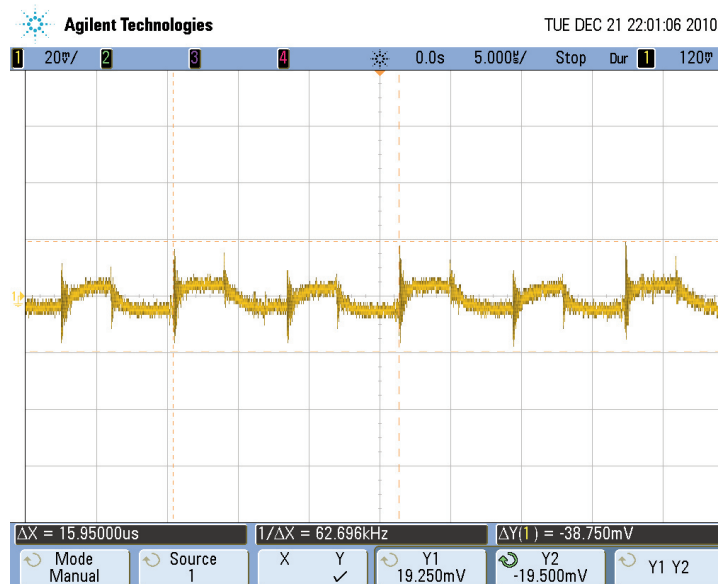
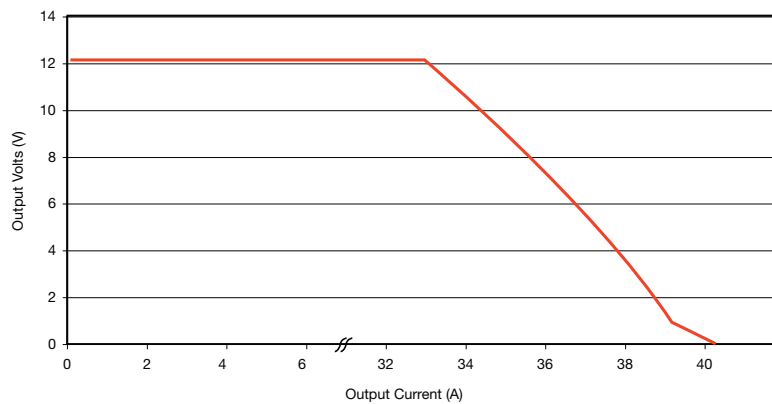

Figure 5
V1 FCM400PS24 (full load)
38 mV pk-pk ripple. 20 MHz BW



Output Overload Characteristic

Figure 6
Typical V1 Overload
Characteristic
(FCM400PS12 shown)



General Specifications

Characteristic	Minimum	Typical	Maximum	Units	Notes & Conditions
Efficiency		87		%	Full load (see fig.7 & 8)
Isolation: Input to Output Input to Ground Output to Ground	4000			VAC	
	1500			VAC	
	500			VAC	
Switching Frequency		70 / 65		kHz	PFC / Main Converter.
Power Density			13.9	W/in ³	
Mean Time Between Failure		236		kHrs	MIL-HDBK-217F, Notice 2 +25 °C GB
Weight		1.8 (800)		lb (g)	

Efficiency Versus Load

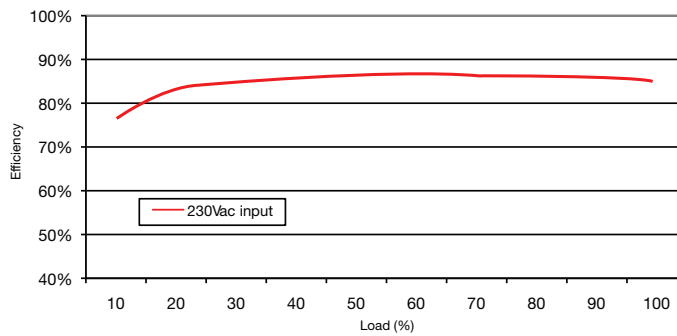

Figure 7
FCM400PS12

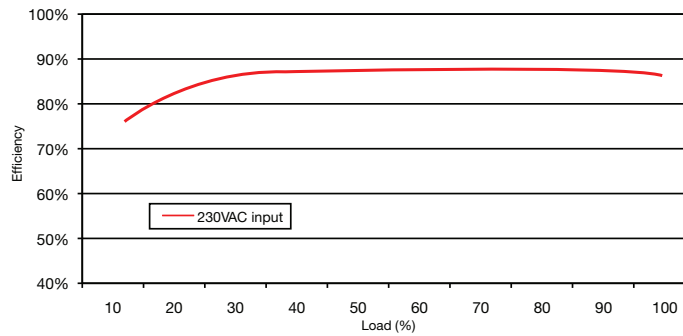

Figure 8
FCM400PS24

Characteristic	Notes & Conditions
Signals	
Power Fail	Uncommitted opto isolated transistor, normally off when AC is good (see fig.9 - 11) Provides ≥ 5 ms (typically 20-30ms) warning of loss of output from AC failure
Remote On/Off (Inhibit/Enable)	Uncommitted isolated optocoupler diode, powered diode inhibits the supply (see fig.12-17)
Standby Supply V2	Isolated 5 V/0.5 A supply, always present when AC supplied.

Signals

Power Fail

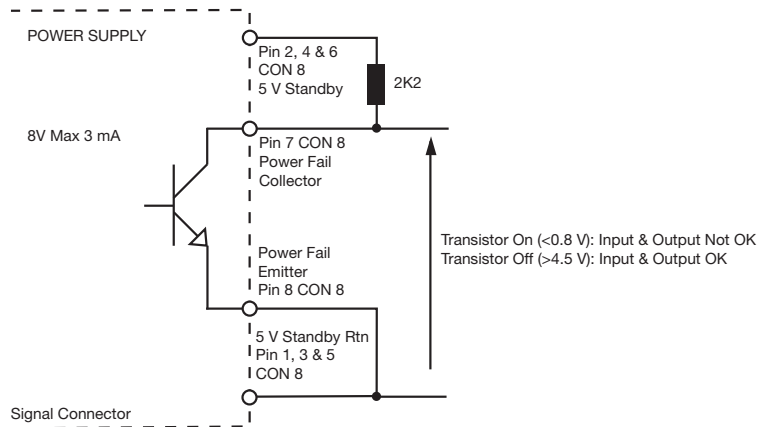

Figure 9

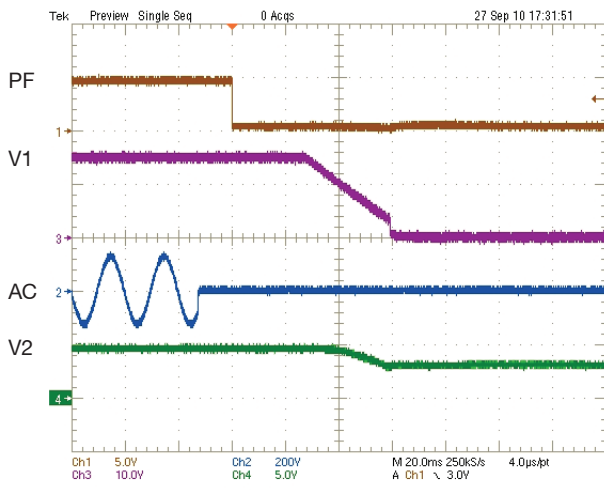

Figure 10
Power Fail signal example
at AC switch off

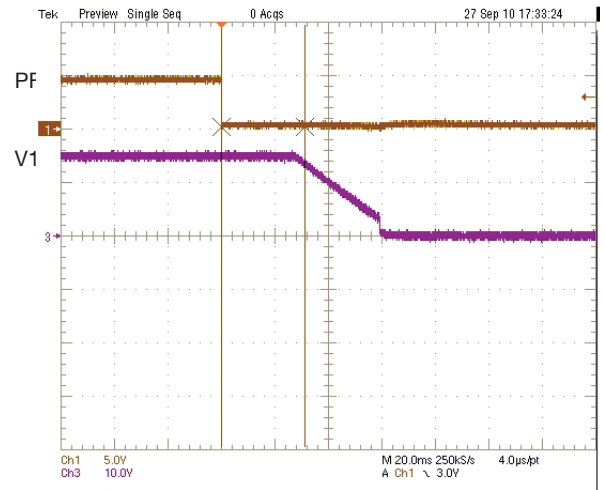

Figure 11
V1 warning time example at Power Fail signal 230
VAC 400 W load (31 ms)

Signals

Remote On/Off (Inhibit/Enable)

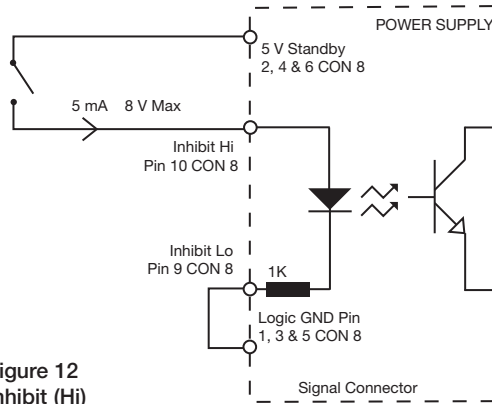

Figure 12
Inhibit (Hi)

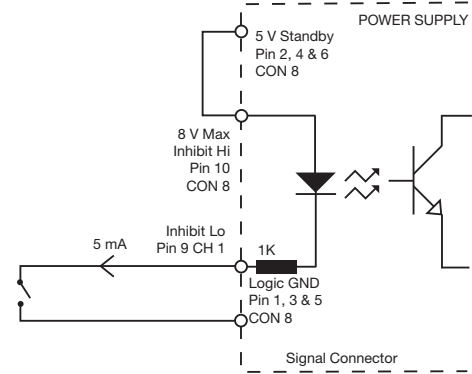

Figure 13
Inhibit (Lo)

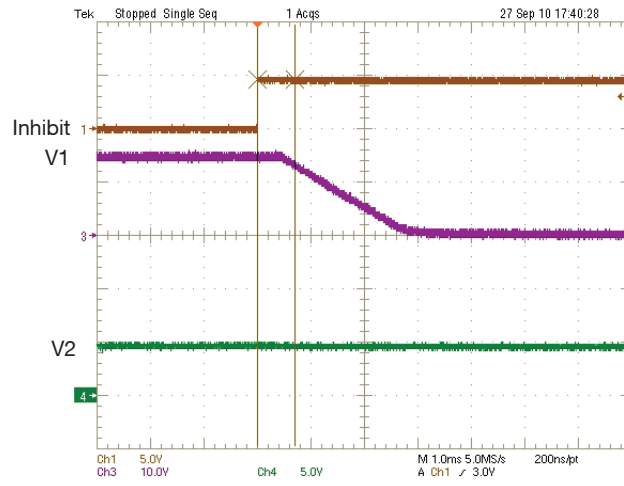

Figure 14
Example of outputs
switching off when
Inhibit (Lo) configuration
used & switch closed

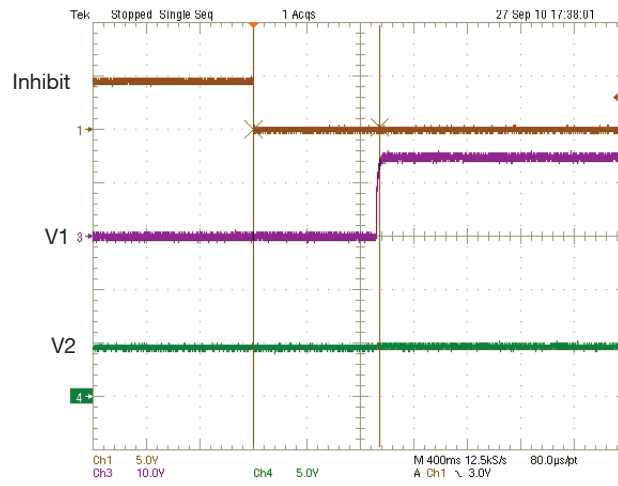

Figure 15
Example of outputs
switching on when
Inhibit (Lo) configuration
used & switch open

Signals

Remote On/Off (Inhibit/Enable)

Figure 16
Enable (Hi)

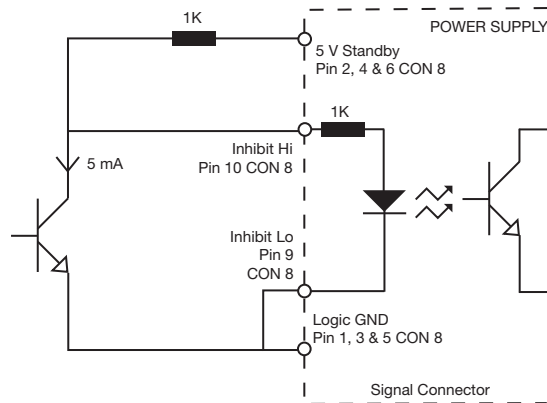
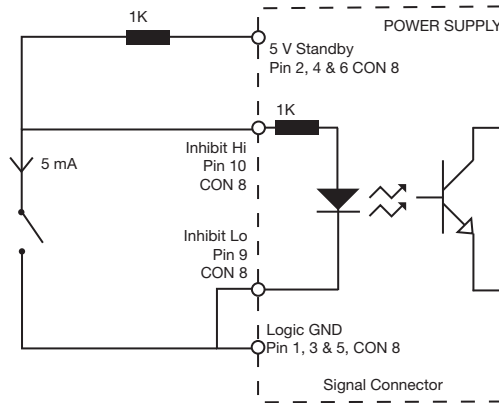

Figure 17
Enable (Lo)



Notes

1. At AC switch on the output (V) may momentarily rise when the unit is disabled using the 5V standby in conjunction with the Remote On/Off function.

Environmental

Characteristic	Minimum	Typical	Maximum	Units	Notes & Conditions
Operating Temperature	-10		+70	°C	Derate linearly from +50 °C at 2.5%/°C to 50% at 70 °C. See fig.18.
Warm up Temperature		20		Minutes	
Storage Temperature	-40		+85	°C	
Cooling					Forced cooled via low noise integral fan
Humidity	5		95	%RH	Non-condensing
Operating Altitude			3000	m	
Shock					3 x 30 g/11 ms shocks in both +ve & -ve directions along the 3 orthogonal axis, total 18 shocks.
Vibration					Single axis 10-500 Hz at 2 g x 10 sweeps

Derating Curve

Figure 18

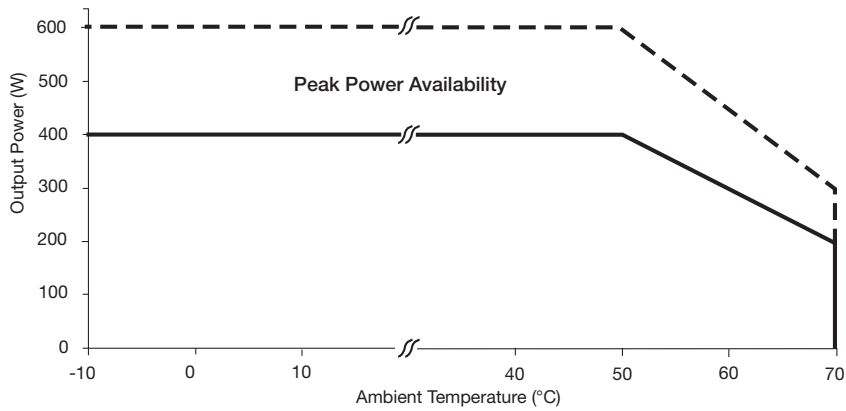

Electromagnetic Compatibility - Immunity

Phenomenon	Standard	Test Level	Criteria	Notes & Conditions
Low Voltage PSU EMC	EN61204-3	High severity level	as below	
Harmonic Current	EN61000-3-2	Class A		
Radiated	EN61000-4-3	3	A	
EFT	EN61000-4-4	3	A	
Surges	EN61000-4-5	Installation class 3	A	
Conducted	EN61000-4-6	3	A	
Dips and Interruptions	EN61000-4-11	Dip: 30% 10 ms	A	
		Dip: 60% 100 ms	B	
		Dip: 100% 5000 ms	B	
	EN60601-1-2 (EN61000-4-11)	Dip: 30% 500 ms	A	
		Dip: 60% 100 ms	A	Requires load derating to approx 80% with 100 VAC input.
		Int.: >95% 5000 ms	B	

Electromagnetic Compatibility - Emissions

Phenomenon	Standard	Test Level	Criteria	Notes & Conditions
Conducted	EN55011/22	Class B		
Radiated	EN55011/22	Class A		
Voltage Fluctuations	EN61000-3-3			

Safety Agency Approvals

Safety Agency	Safety Standard	Category
CB Report	UL Cert #US/15598/UL, IEC60950-1:2005 Ed 2, IEC62368-1:2014 Ed 2	Information Technology
UL	UL Filed #E139109-A43-UL, UL60950-1(2007), CSA 22.2 No60950-1-07 Ed2, UL62368-1 (2014) , CSA 22.2 No.62368-1-14 Ed 2	Information Technology
TUV	TUV Certificate # B 10 09 57396 081, EN 60950-1/A2:2013, EN 62368-1:2014/A11:2017	Information Technology
CE	LVD	

Safety Agency	Safety Standard	Category
CB Report	Certificate #US/17946/UL, IEC60601-1 Ed 3 Including Risk Management	Medical
UL	UL File # E146893, ANSI/AAMI ES 60601-1:2005 & CSA C22.2 No. 60601-1:08	Medical
TUV	EN60601-1:2006	Medical

Means of Protection		Category
Primary to Secondary	2 x MOPP (Means of Patient Protection)	IEC60601-1 Ed 3
Primary to Earth	1 x MOPP (Means of Patient Protection)	

Equipment Protection Class	Safety Standard	Notes & Conditions
Class I	IEC60950-1:2005 Ed 2 & IEC60601-1 Ed 3	See safety agency conditions of acceptability for details

Mechanical Details

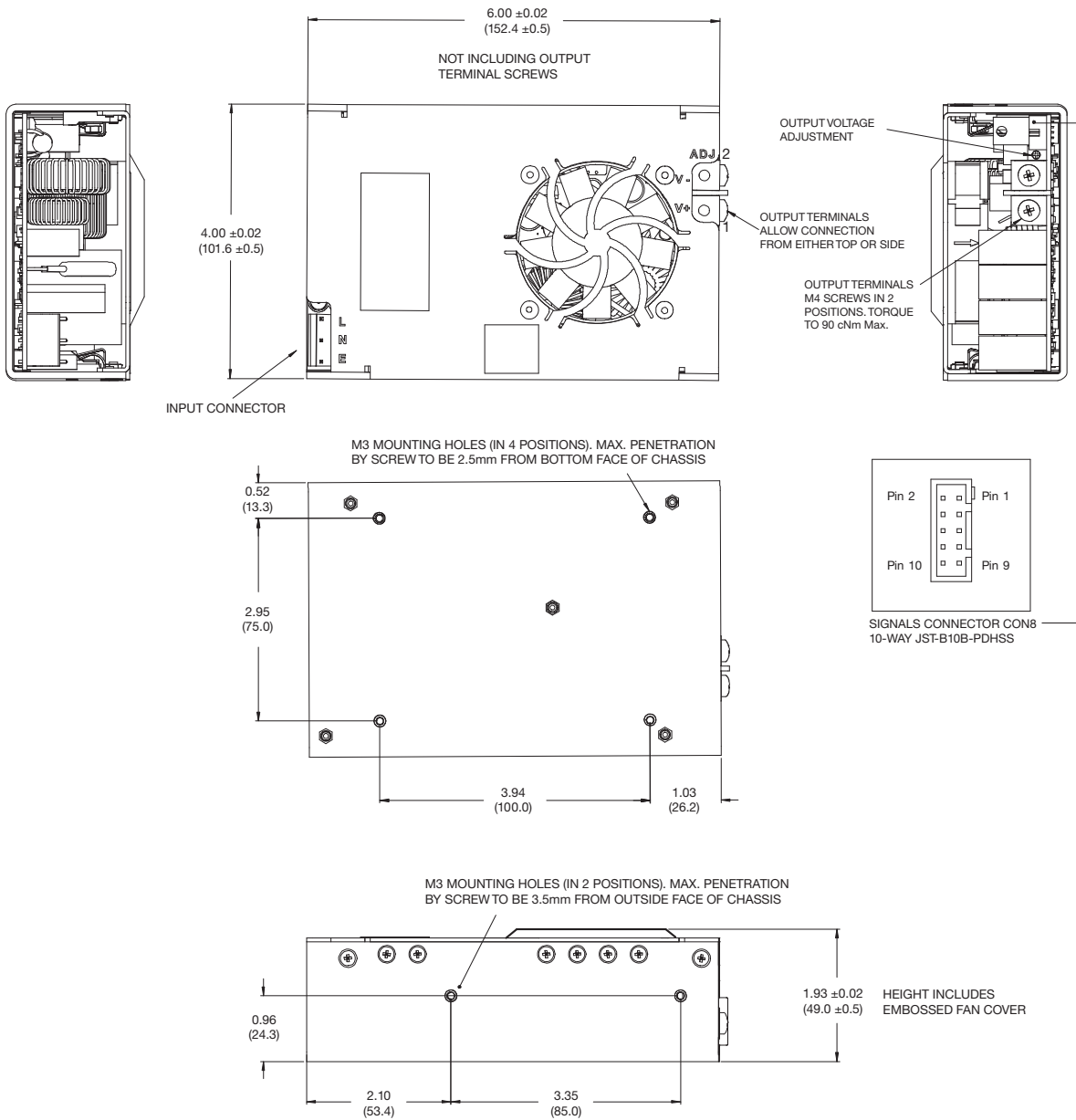

Notes

- Dimensions shown in inches (mm). Tolerance: ±0.02 (±0.5)
- Weight: 1.8 lb (800g).

Signals Connector CON 8	
1	5 V Standby Return
2	5 V Standby
3	5 V Standby Return
4	5 V Standby
5	5 V Standby Return
6	5 V Standby
7	Power Fail (Collector)
8	Power Fail (Emitter)
9	Remote On / Off (Cathode)
10	Remote On / Off (Anode)

Mating plug: JST p/n PHDR-10VS

Contact: 26-22 AWG JST p/n SPHD-001T-P0.5

Input Connector CON 2 Tyco part #640445-5	
Pin 1	Line
Pin 2	Neutral
Pin 3	Earth

J1 mates with Tyco MTA-156 & 5L-156 product lines