

CGHV27060MP

60 W, DC - 2.7 GHz, 50 V, GaN HEMT for Communication Amplifiers and Pulse Radar Applications

Description

Cree's CGHV27060MP is a 60 W gallium nitride (GaN) high electron mobility transistor (HEMT) housed in a small plastic SMT package 4.4 mm x 6.5 mm. The transistor is a broadband device with no internal input or output match which allows for the agility to apply to a wide range of frequencies from UHF thru 2.7GHz. The CGHV27060MP makes for an excellent transistor for pulsed applications at UHF, L Band, or low S Band (<2.7GHz). Additionally, the transistor is well suited for communication amplifiers in the power class of 10 to 15 W average power in high efficiency topologies such as Class A/B, F, or Doherty amplifiers.

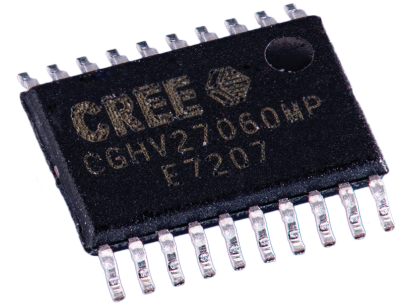

PN: CGHV27060MP

Typical Performance Over 2.5 - 2.7 GHz (TC = 25 ° C) of Demonstration Amplifier

Parameter	2.5 GHz	2.6 GHz	2.7 GHz	Units
Gain	16.7	16.4	16.2	dB
Output Power	94	87	83	W
Drain Efficiency	69	69	64	%

Note: Measured in the CGHV27060MP-AMP1 amplifier circuit, under pulse width 100 μ s, 10% duty cycle, P_{IN} = 33 dBm.

Typical Performance Over 2.5 - 2.7 GHz (TC = 25 ° C) of Demonstration Amplifier

Parameter	2.5 GHz	2.6 GHz	2.7 GHz	Units
Gain	18.4	18.2	17.6	dB
ACLR	-33.2	-34.5	-35.8	dBc
Drain Efficiency	33	33	32	%

Note: Measured in the CGHV27060MP-AMP1 amplifier circuit, under WCDMA 3GPP test model 1, 64 DPCH, 45% clipping, PAR = 7.5 dB @ 0.01% probability on CCDF, VDD = 50 V, IDS = 125 mA, PAVE = 41.5 dBm

Features - Pulsed

- 16.5 dB Gain at Pulsed P_{SAT}
- 70% Efficiency at Pulsed P_{SAT}
- 85 W at Pulsed P_{SAT}

Features - Linear

- 18 dB Gain at P_{AVE} = 14 W
- -35 dBc ACLR at P_{AVE} = 14 W
- 33% Efficiency P_{AVE} = 14 W
- High Degree of DPD Correction Can be Applied

Listing of Available Hardware Application Circuits / Demonstration Circuits

Application Circuit	Operating Frequency	Amplifier Class	Operating Voltage
CGHV27060MP-AMP1	2.5 - 2.7 GHz	Class A/B	50 V
CGHV27060MP-AMP3	0.8 - 2.7 GHz	Class A/B	50 V
CGHV27060MP-AMP4	0.1 - 1.0 GHz	Class A/B	45 V

 Large Signal Models Available for ADS and MWO

RoHS
COMPLIANT



Absolute Maximum Ratings (not simultaneous) at 25 °C Case Temperature

Parameter	Symbol	Rating	Units	Conditions
Drain-Source Voltage	V_{DSS}	150	Volts	25 °C
Gate-to-Source Voltage	V_{GS}	-10, +2	Volts	25 °C
Storage Temperature	T_{STG}	-65, +150	°C	
Operating Junction Temperature	T_J	225	°C	
Maximum Forward Gate Current	I_{GMAX}	10.4	mA	25 °C
Maximum Drain Current ¹	I_{DMAX}	6.3	A	25 °C
Soldering Temperature ²	T_S	245	°C	
Thermal Resistance, Junction to Case ³	$R_{\theta JC}$	2.6	°C/W	85 °C, $P_{DISS} = 52$ W (CW)
Thermal Resistance Pulsed 10%, 100 μ s, Junction to Case	$R_{\theta JC}$	1.95	°C/W	85 °C, $P_{DISS} = 62$ W, 100 μ s/10%
Case Operating Temperature ⁴	T_C	-40, +150	°C	

Notes:

¹ Current limit for long term, reliable operation

² Refer to the Application Note on soldering at wolfspeed.com/rf/document-library

³ Measured for the CGHV27060MP

⁴ See also, the Power Dissipation De-rating Curve on Page 12

Electrical Characteristics ($T_C = 25$ °C)

Characteristics	Symbol	Min.	Typ.	Max.	Units	Conditions
DC Characteristics¹						
Gate Threshold Voltage	$V_{GS(th)}$	-3.8	-3.0	-2.3	V_{DC}	$V_{DS} = 10$ V, $I_D = 10.4$ mA
Gate Quiescent Voltage	$V_{GS(Q)}$	-	-2.7	-	V_{DC}	$V_{DS} = 50$ V, $I_D = 125$ mA
Saturated Drain Current ²	I_{DS}	6.8	9.7	-	A	$V_{DS} = 6.0$ V, $V_{GS} = 2.0$ V
Drain-Source Breakdown Voltage	V_{BR}	125	-	-	V_{DC}	$V_{GS} = -8$ V, $I_D = 10.4$ mA
RF Characteristics⁴ ($T_C = 25$ °C, $F_0 = 2.5$ GHz unless otherwise noted)						
Output Power ³	P_{OUT}	-	95	-	W	$V_{DD} = 50$ V, $I_{DQ} = 125$ mA, $P_{IN} = 35$ dBm
Pulsed Drain Efficiency ³	η	-	64	-	%	$V_{DD} = 50$ V, $I_{DQ} = 125$ mA, $P_{IN} = 35$ dBm
Gain ³	G	-	18.3	-	dB	$V_{DD} = 50$ V, $I_{DQ} = 125$ mA, $P_{IN} = 10$ dBm
Output Mismatch Stress ³	VSWR	-	-	10:1	Ψ	No damage at all phase angles, $V_{DD} = 50$ V, $I_{DQ} = 125$ mA, $P_{OUT} = 60$ W Pulsed
Dynamic Characteristics						
Input Capacitance ⁵	C_{GS}	-	15.3	-	pF	$V_{DS} = 50$ V, $V_{GS} = -8$ V, $f = 1$ MHz
Output Capacitance ⁵	C_{DS}	-	4.7	-	pF	$V_{DS} = 50$ V, $V_{GS} = -8$ V, $f = 1$ MHz
Feedback Capacitance	C_{GD}	-	0.5	-	pF	$V_{DS} = 50$ V, $V_{GS} = -8$ V, $f = 1$ MHz

Notes:

¹ Measured on wafer prior to packaging

² Scaled from PCM data

³ Pulse Width = 100 μ s, Duty Cycle = 10%

⁴ Measured in CGHV27060MP-TB high volume test fixture

⁵ Includes package



Electrical Characteristics When Tested in CGHV27060MP-AMP1 Under WCDMA Modulation

Characteristics	Symbol	Frequency (GHz)	Min.	Typ.	Max.	Units	Conditions
RF Characteristics^{2,3} (T_c = 25 °C)							
Small Signal Gain ²	G _{SS}	2.6	-	19.2	-	dB	V _{DD} = 50 V, I _{DQ} = 125 mA, P _{IN} = 10 dBm
Gain ²	G	2.5	-	18.4	-	dB	V _{DD} = 50 V, I _{DQ} = 125 mA, P _{IN} = 41.5 dBm
Gain ²	G	2.6	-	18.6	-	dB	V _{DD} = 50 V, I _{DQ} = 125 mA, P _{IN} = 41.5 dBm
Gain ²	G	2.7	-	18.1	-	dB	V _{DD} = 50 V, I _{DQ} = 125 mA, P _{IN} = 41.5 dBm
ACLR ²	ACLR	2.5	-	-35	-	dBc	V _{DD} = 50 V, I _{DQ} = 125 mA, P _{IN} = 41.5 dBm
ACLR ²	ACLR	2.6	-	-35	-	dBc	V _{DD} = 50 V, I _{DQ} = 125 mA, P _{IN} = 41.5 dBm
ACLR ²	ACLR	2.7	-	-35	-	dBc	V _{DD} = 50 V, I _{DQ} = 125 mA, P _{IN} = 41.5 dBm
Drain Efficiency ^{2,3}	η	2.5	-	32	-	%	V _{DD} = 50 V, I _{DQ} = 125 mA, P _{IN} = 41.5 dBm
Drain Efficiency ^{2,3}	η	2.6	-	33	-	%	V _{DD} = 50 V, I _{DQ} = 125 mA, P _{IN} = 41.5 dBm
Drain Efficiency ^{2,3}	η	2.7	-	31	-	%	V _{DD} = 50 V, I _{DQ} = 125 mA, P _{IN} = 41.5 dBm

Notes:

¹ Measured in CGHV27060MP-AMP1 Application Circuit

² Single Carrier WCDMA, 3GPP Test Model 1, 64 DPCH, 45% Clipping, PAR = 7.5 dB @ 0.01% Probability on CCDF

³ Drain Efficiency = P_{OUT} / P_{DC}

Typical Performance in Application Circuit CGHV27060MP-AMP1

Figure 1. Small Signal Gain and Return Losses of the CGHV27060MP Measured in Demonstration Amplifier Circuit CGHV27060MP-AMP1

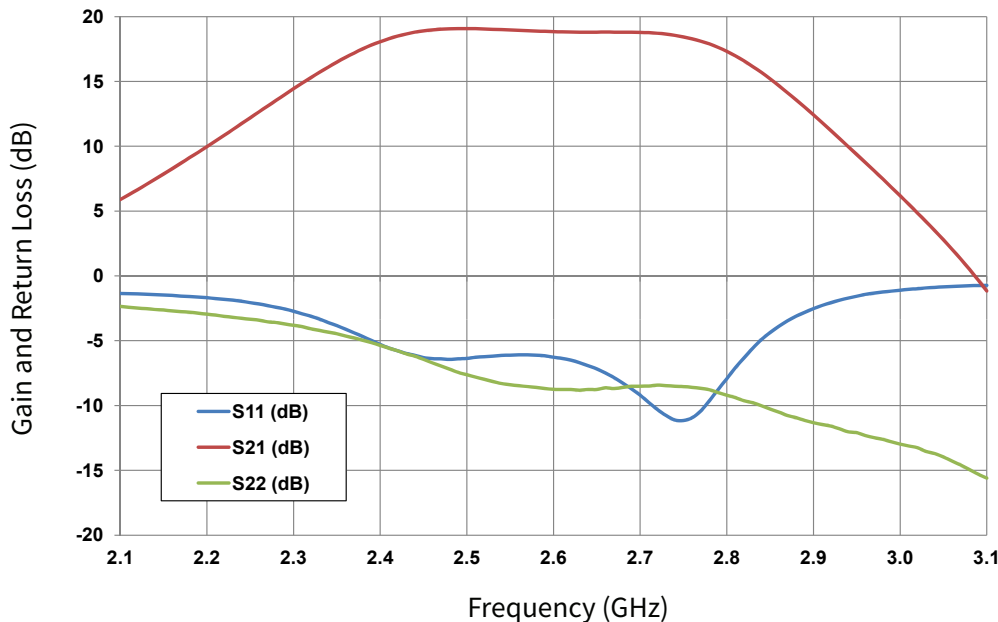



Typical Performance in Application Circuit CGHV27060MP-AMP1

Figure 2. Gain, Output Power, and Drain Efficiency under 100 μ s Pulse Width, 10% Duty Cycle for the CGHV27060MP Measured in Demonstration Amplifier Circuit CGHV27060MP-AMP1

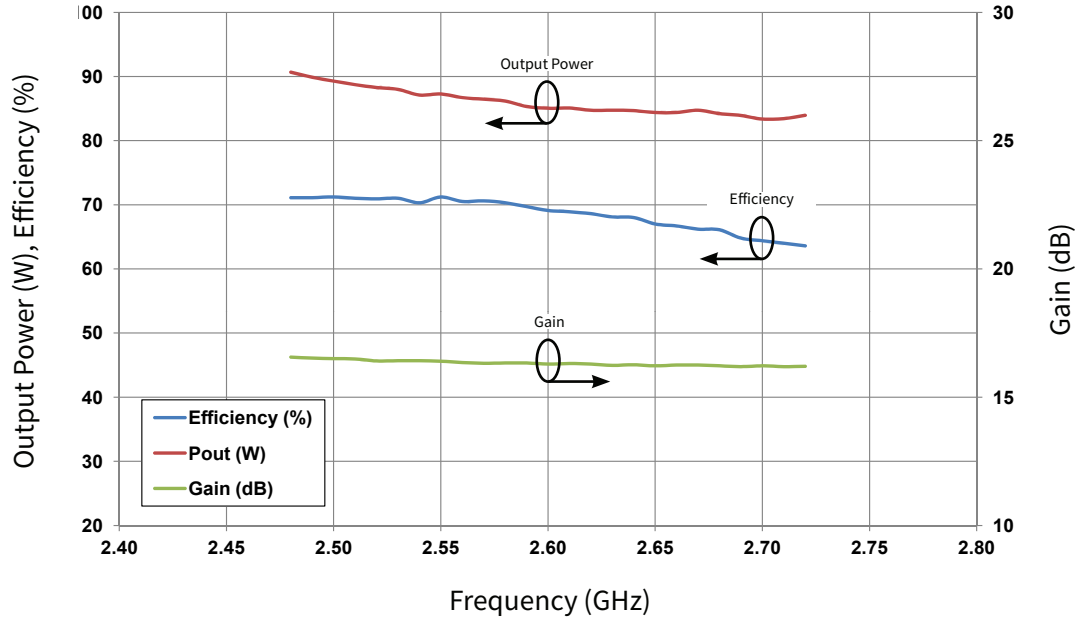



Electrical Characteristics When Tested in CGHV27060MP-AMP3, MILCOM

Characteristics	Symbol	Min.	Typ.	Max.	Units	Conditions
RF Characteristics¹ (T_c = 25° C, F₀ = 0.8 - 2.7 GHz unless otherwise noted)						
Gain	G	-	16.5	-	dB	V _{DD} = 50 V, I _{DQ} = 120 mA, P _{IN} = 0 dBm
Output Power	P _{OUT}	-	48.5	-	dBm	V _{DD} = 50 V, I _{DQ} = 120 mA, P _{IN} = 37 dBm
Drain Efficiency	η	-	60	-	%	V _{DD} = 50 V, I _{DQ} = 120 mA, P _{IN} = 37 dBm
Output Mismatch Stress	VSWR	-	3 : 1	-	Ψ	No damage at all phase angles, V _{DD} = 50 V, I _{DQ} = 120 mA, P _{IN} = 37 dBm

Note: Measured in CGHV27060MP-AMP3 Application Circuit

Typical Performance in Application Circuit CGHV27060MP-AMP3, MILCOM

Figure 3. Small Signal Gain and Return Losses Measured of the CGHV27060MP Measured in Demonstration Amplifier Circuit CGHV27060MP-AMP3
 V_{DD} = 50 V, I_{DQ} = 120 mA

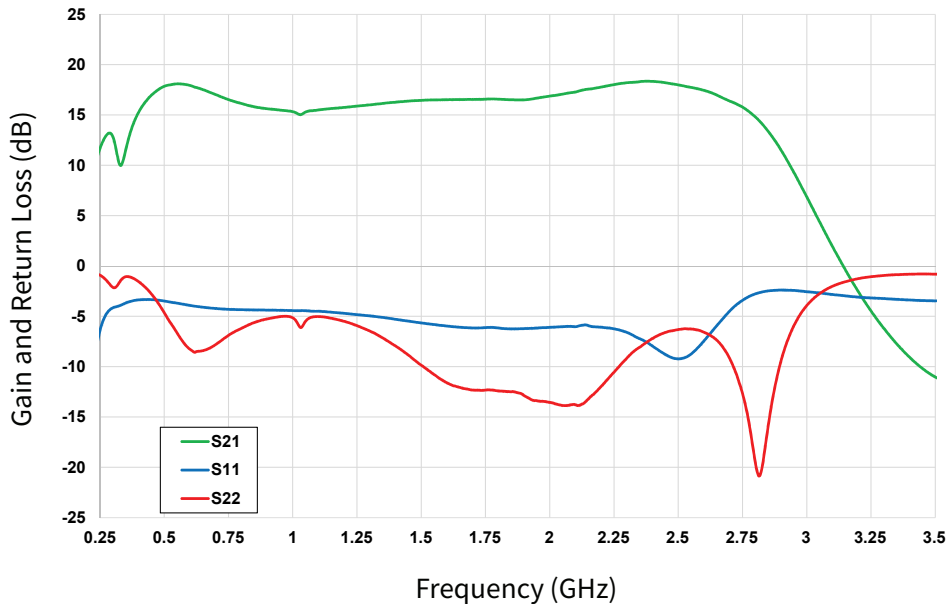

Typical Performance in Application Circuit CGHV27060MP-AMP3

Figure 4. Power, Drain Efficiency and Gain vs Frequency of CGHV27060MP-AMP3
 $P_{IN} = 37 \text{ dBm}$, $V_{DD} = 50 \text{ V}$, $I_{DQ} = 120 \text{ mA}$

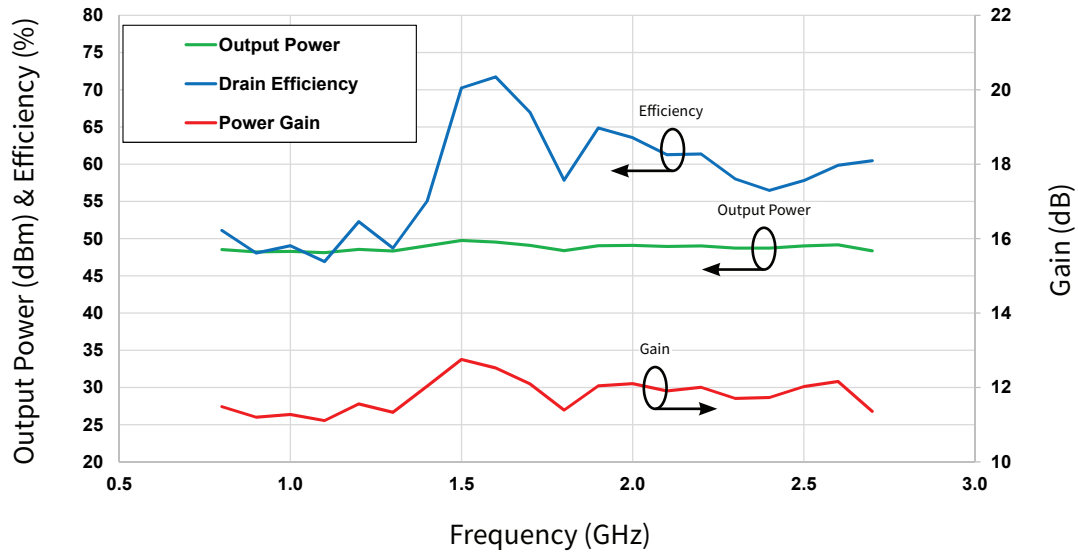



CGHV27060MP-AMP3 Demonstration Amplifier Circuit Schematic

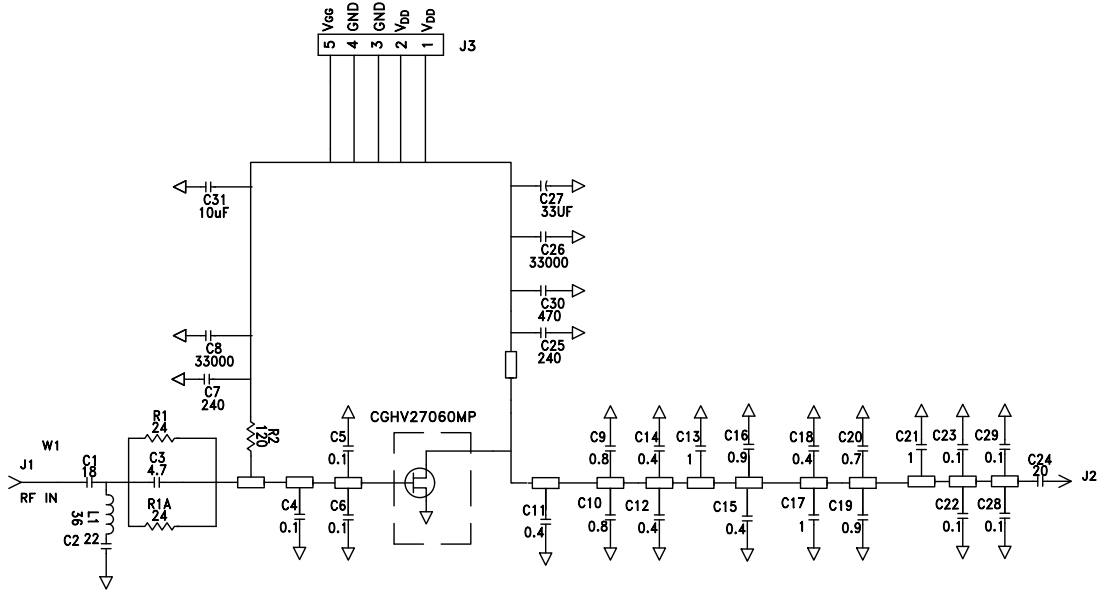

CGHV27060MP-AMP3 Demonstration Amplifier Circuit Outline

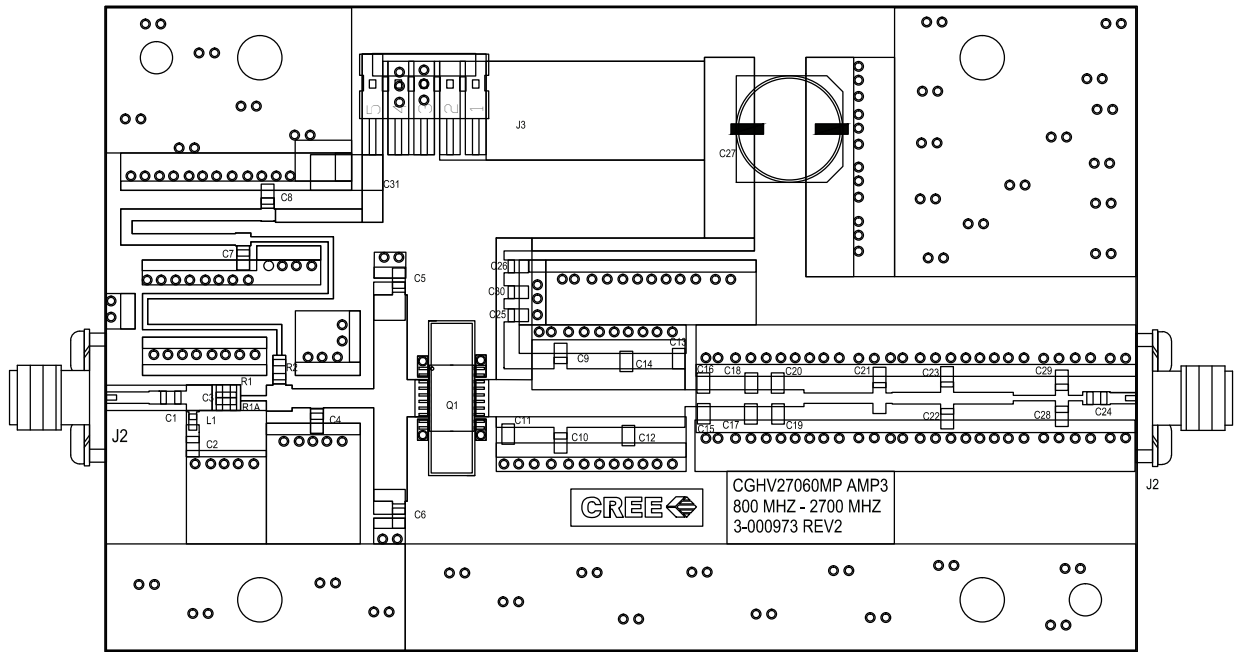

CGHV27060MP-AMP3 Bill of Materials

Designator	Description	Qty
C1	CAP, 18PF, 5%, 0805, ATC	1
C2	CAP, 22PF, 5%, 0805, ATC	1
C3	CAP, 4.7PF, 5%, 0805, ATC	1
C4,C5,C6, C22, C23, C28, C29	CAP, 0.1PF, 5%, 0805, ATC	7
C7, C25	CAP, 240pF, 5%, 0805, ATC	2
C8,C26	CAP, 33000pF, 0805,100V,X7R	2
C16,C19,	CAP, 0.9pF, 5%, 0805, ATC	2
C9, C10	CAP, .8pF,5%, 0805, ATC	2
C11,C12,C14,C15,C18	CAP, 0.4pF, 5%, 0805, ATC	5
C13,C17,C21	CAP, 1pF, 5%, 0805, ATC	3
C24	CAP, 20pF, 5%, 0805, ATC	1
C30	CAP, 470pF, 5%, 0603, X7R	1
C27	CAP, 33 uF	1
C31	CAP, 10uF, 16V, TANTALUM	1
C20	CAP 0.7pF	1
L1	IND, 36nH, 603	1
R1,R1A	RES, 24 Ohms, 805 IMS	1
R2	RES,120 Ohms, 0805	1
-	PCB, RO4350, CGHV27060MP Applications Board, 4" X 2.5"X0.02"	1
-	BASEPLATE, Cu, 4"X2.5"X0.5"	1
-	2-56 SOC HD SCREW 1/4 SS	4
-	#2 SPLIT LOCKWASHER SS	4
J1,J2	CONN, SMA, PANEL MOUNT JACK, FLANGE, 4-HOLE, BLUNT POST, 20MIL	2
J3	HEADER RT>PLZ .1CEN LK 5POS	1
Q1	Transistor CGHV27060MP	1

Electrical Characteristics When Tested in CGHV27060MP-AMP4, MILCOM

Characteristics	Symbol	Min.	Typ.	Max.	Units	Conditions
RF Characteristics ¹ (T _c = 25 ° C, F ₀ = 0.1 - 1.0 GHz unless otherwise noted)						
Small Signal Gain	G	-	16.5	-	dB	V _{DD} = 45 V, I _{DQ} = 120 mA
Output Power	P _{OUT}	-	47.8	-	dBm	V _{DD} = 45 V, I _{DQ} = 120 mA, P _{IN} = 35 dBm
Drain Efficiency	η	-	51.1	-	%	V _{DD} = 45 V, I _{DQ} = 120 mA, P _{IN} = 35 dBm
Output Mismatch Stress	VSWR	-	3 : 1	-	Ψ	No damage at all phase angles, V _{DD} = 45 V, I _{DQ} = 120 mA, P _{IN} = 35 dBm

Note: Measured in CGHV27060MP-AMP4 Application Circuit



Typical Performance in Application Circuit CGHV27060MP-AMP4, MILCOM

Figure 5. Small Signal Gain and Return Losses of the CGHV27060MP Measured in Demonstration Amplifier Circuit CGHV27060MP-AMP4
 $V_{DD} = 45\text{ V}, I_{DQ} = 120\text{ mA}$

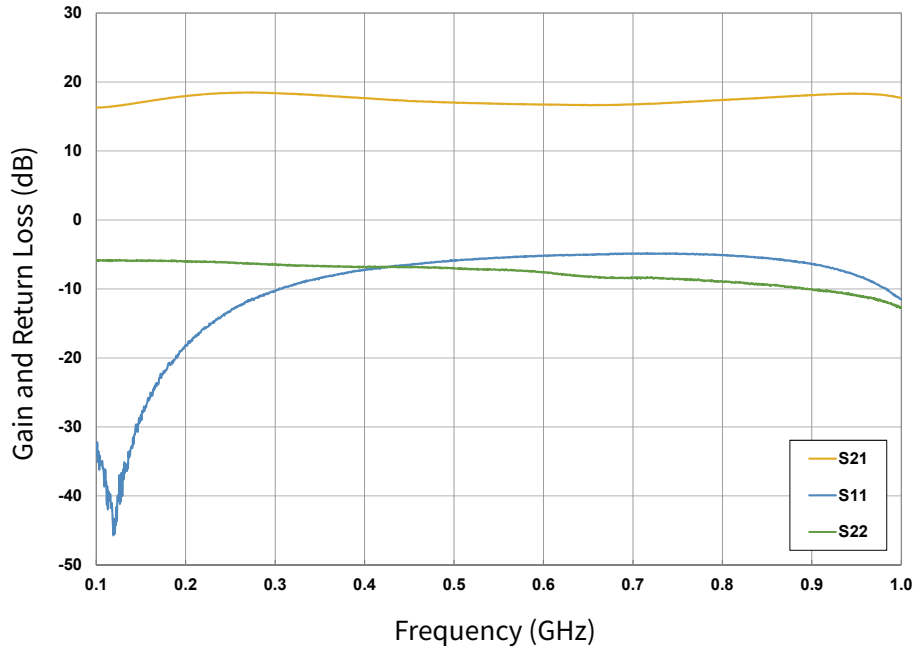
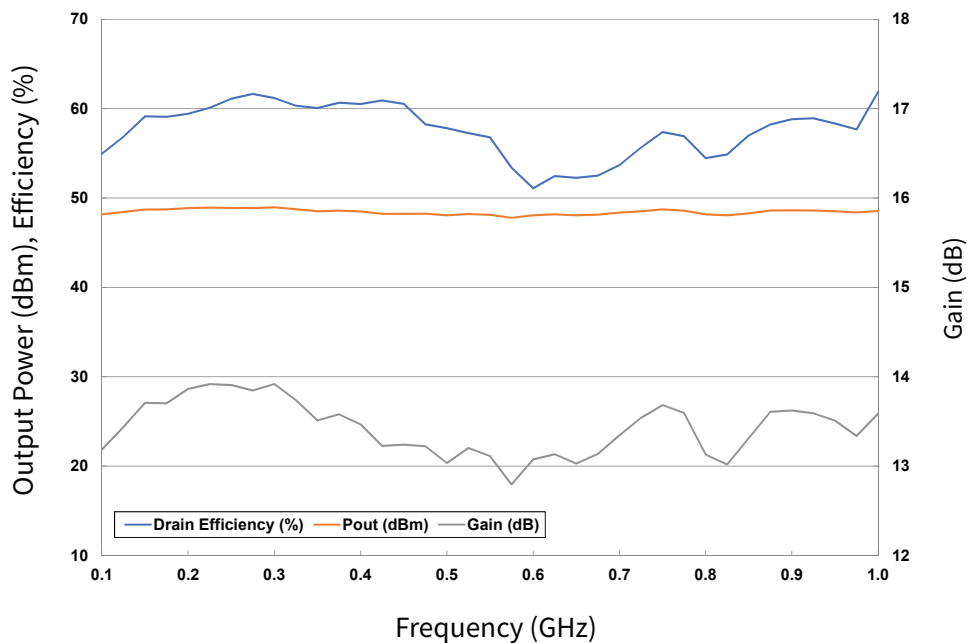
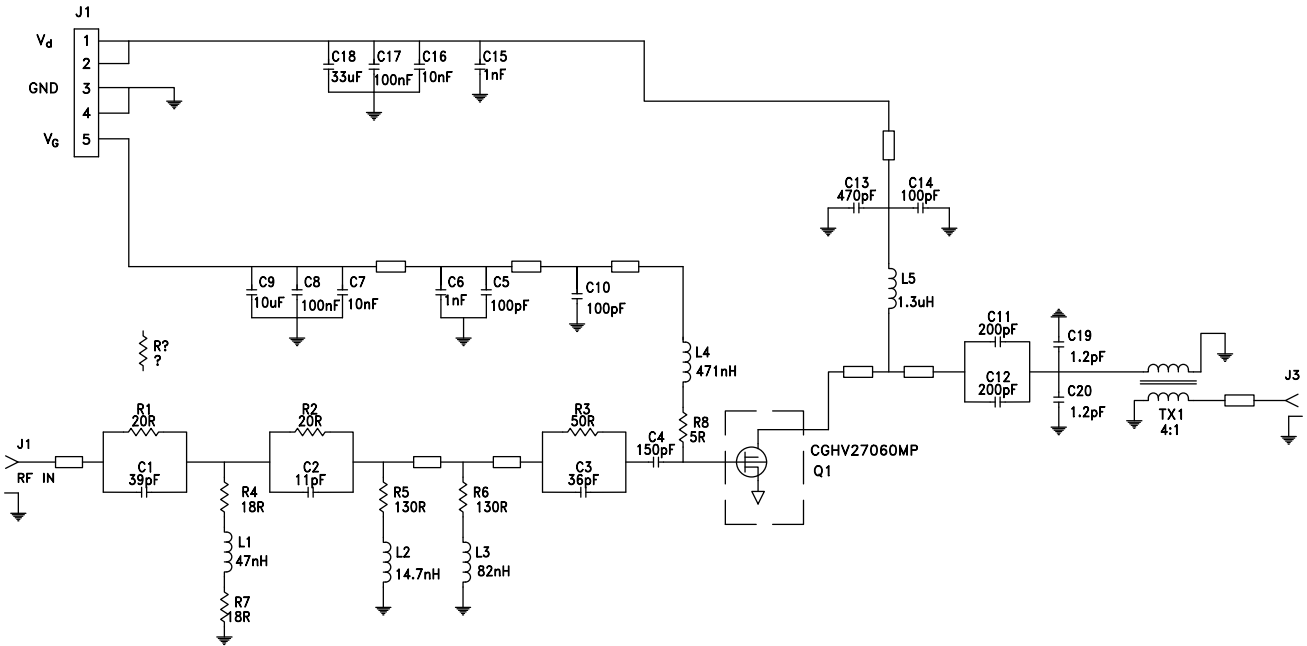

Figure 6. Power, Drain Efficiency, and Gain vs Frequency for the CGHV27060MP Measured in Demonstration Amplifier Circuit CGHV27060MP-AMP4
 $V_{DD} = 45\text{ V}, I_{DQ} = 120\text{ mA}$



CGHV27060MP-AMP4 Demonstration Amplifier Circuit Schematic



CGHV27060MP-AMP4 Demonstration Amplifier Circuit Outline

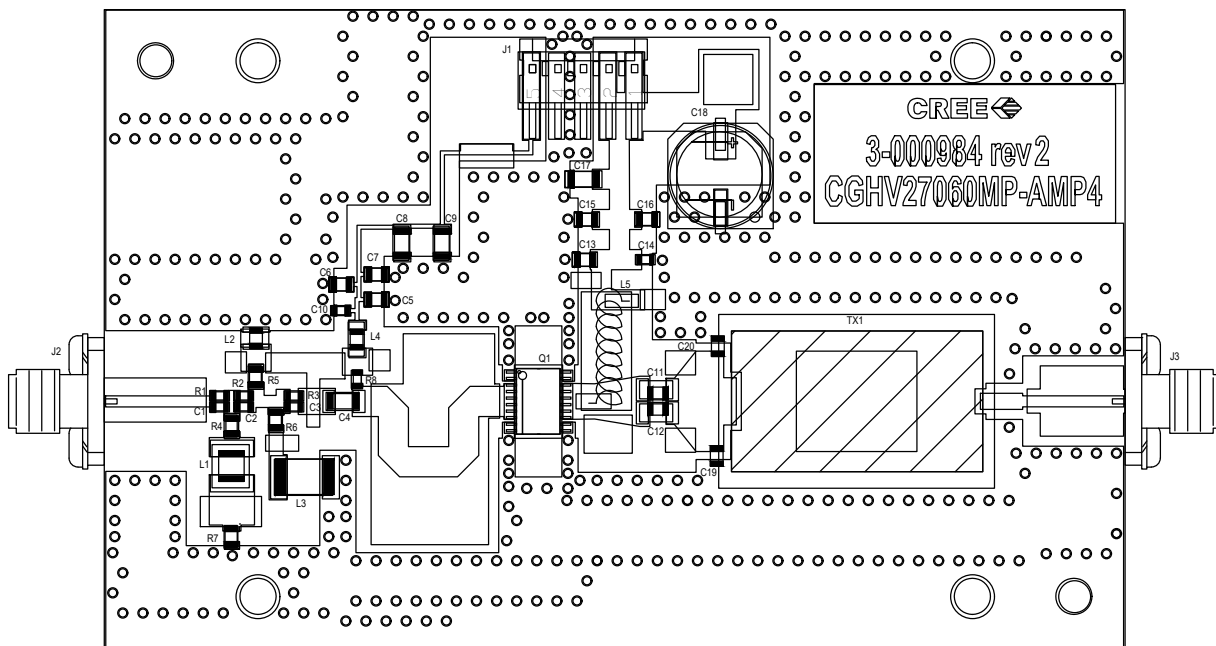

CGHV27060MP-AMP4 Bill of Materials

Designator	Description	Qty
R4,7	RES,16W,0805,2%,18 OHMS, IMS	2
R1,2	RES, 13W,0603,5%, 20 OHMS, IMS	2
R3	RES,13W,0603,5%, 50 OHMS, IMS	1
R5, 6	RES, 25W,0805,5%, 130 OHMS, IMS	2
C19, C20	CAP, 1.2pF, +/-0.1pF, 0805, ATC600F	2
C2	CAP, 11pF, +/-2%, 0603, ATC600S	1
C3	CAP, 36pF, +/-2%, 0603, ATC600S	1
C1	CAP, 39pF, +/-2%, 0603, ATC600S	1
C10,14	CAP, 100pF, +/-5%, 0603, 100V, COG	2
C4	CAP, 150pF, +/-5%, ATC800B	1
C11, 12	CAP, 200pF, +/-5%, 0805, ATC600F	2
C5, 13	CAP, 470pF, +/-5%, 0805, 100V, X7R	2
C6, 15	CAP,1NF, 0805,100V, X7R	2
C7, 16	CAP,10NF, 0805,100V, X7R	2
C8, 17	CAP,100NF, 1206,100V, X7R	2
C9	CAP, 10UF, 10%, 1206,16V, X5R	1
C18	CAP, 33UF, 20%, F CASE, 63V	1
L2	IND, 14.7nH, 2% Air Core, Coilcraft	1
L1	IND, 47nH, 5% Air Core, Coilcraft	1
L3	IND, 82nH, 5% Air Core, Coilcraft	1
L4	IND, 471nH, 5%, 0805 Chip Inductor, Coilcraft	1
-	Copper Plate	1
J2,J3	CONN, SMA, PANEL MOUNT JACK, FLANGE, 4-HOLE, BLUNT POST	2
-	PCB, Rogers RO4350B 20mils 1oz.Cu 101x64mm	1
-	BASEPLATE, 4.00 X 2.50 X .49" modified	1
J1	HEADER RT>PLZ .1CEN LK 5POS	1
-	2-56 SOC HD SCREW 1/4 SS	4
-	#2 SPLIT LOCKWASHER SS	4
TX1	Transformer, 30-1000 MHz SMD, IPP-5014	1
Q1	Transistor CGHV27060MP	1

Electrostatic Discharge (ESD) Classifications

Parameter	Symbol	Class	Test Methodology
Human Body Model	HBM	1A (> 250 V)	JEDEC JESD22 A114-D
Charge Device Model	CDM	2 (125 V to 250 V)	JEDEC JESD22 C101-C

Moisture Sensitivity Level (MSL) Classification

Parameter	Symbol	Level	Test Methodology
Moisture Sensitivity Level	MSL	3 (168 hours)	IPC/JEDEC J-STD-20

CGHV27060MP Power Dissipation De-rating Curve

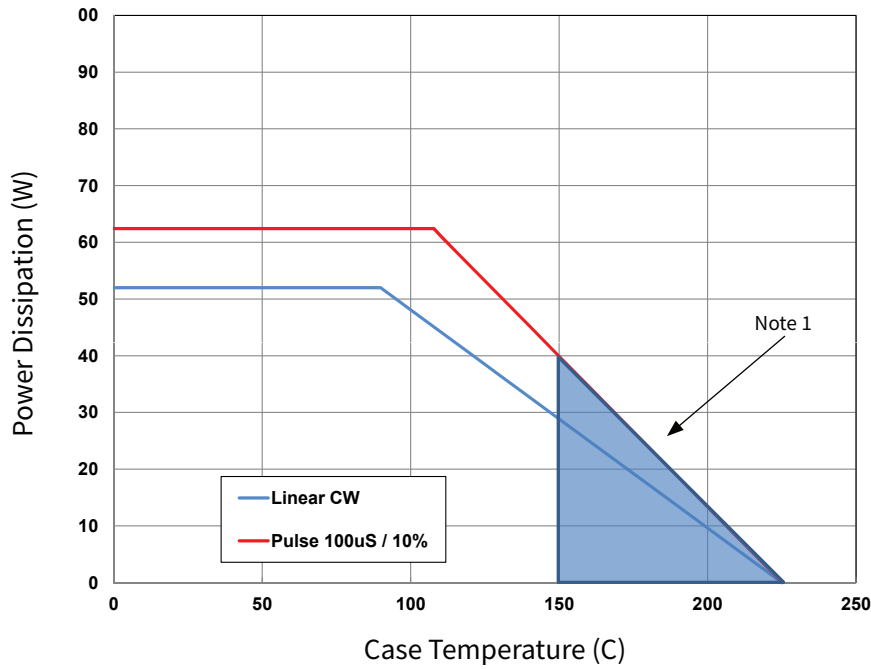

Note 1. Area exceeds Maximum Case Temperature (See Page 2).

Product Dimensions CGHV27060MP (4.4 mm 20-Lead Package)

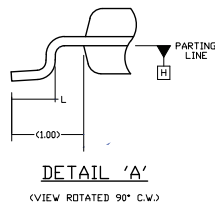
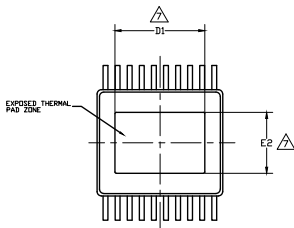
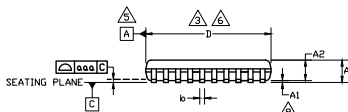
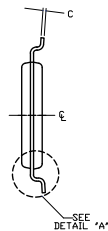
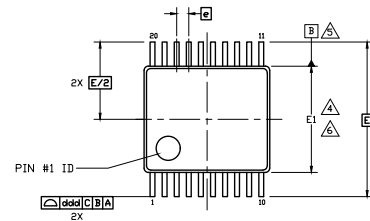

NOTES:

- ALL DIMENSIONS ARE IN MILLIMETERS (ANGLES IN DEGREES).
- DIMENSIONING & TOLERANCES PER ASME, Y14.5M-1994.
- DIMENSION 'D' DOES NOT INCLUDE MOLD FLASH, PROTRUSIONS OR GATE BURRS. MOLD FLASH, PROTRUSIONS OR GATE BURRS SHALL NOT EXCEED 0.15 PER SIDE.
- DIMENSION 'E1' DOES NOT INCLUDE INTERLEAD FLASH OR PROTRUSION. INTERLEAD FLASH OR PROTRUSION SHALL NOT EXCEED 0.25 PER SIDE.
- DATUMS A AND B TO BE DETERMINED AT DATUM PLANE H.
- DIMENSIONS 'D' AND 'E1' TO BE DETERMINED AT DATUM PLANE H.
- 'D1' AND 'E2' DIMENSIONS DO NOT INCLUDE MOLD FLASH.
- A1 IS DEFINED AS THE VERTICAL CLEARANCE FROM THE SEATING PLANE TO THE LOWEST POINT ON THE PACKAGE BODY.
- ALL PLATED SURFACES ARE 100% TIN MATTE FINISH. 0.010 mm +/- 0.005 mm.

S _N H _B G _L	COMMON DIMENSIONS			N _D E
	MIN.	NOM.	MAX.	
A	-	-	1.15	
A1	0.05	-	0.15	8
A2	0.80	0.91	1.02	
aaa	-	0.076	-	
b	0.20	-	0.33	
c	0.10	-	0.23	
D	6.40	6.50	6.60	3.6
E1	4.30	4.40	4.50	4.6
E	-	0.65 BSC	-	
E	-	6.40 BSC	-	
L	0.45	0.60	0.75	
D1	3.61	3.72	3.83	7
E2	2.41	2.52	2.63	7
ddd	-	0.20	-	

PINOUT TABLE

PIN	FUNCTION
1	GND
2	GND
3	RF INPUT
4	RF INPUT
5	RF INPUT
6	RF INPUT
7	RF INPUT
8	RF INPUT
9	GND
10	GND
11	GND
12	GND
13	RF OUTPUT
14	RF OUTPUT
15	RF OUTPUT
16	RF OUTPUT
17	RF OUTPUT
18	RF OUTPUT
19	GND
20	GND

Part Number System

CGHV27060MP



Table 1.

Parameter	Value	Units
Upper Frequency ¹	2.7	GHz
Power Output	60	W
Package	MP	-



Note¹: Alpha characters used in frequency code indicate a value greater than 9.9 GHz. See Table 2 for value.

Table 2.

Character Code	Code Value
A	0
B	1
C	2
D	3
E	4
F	5
G	6
H	7
J	8
K	9
Examples:	1A = 10.0 GHz 2H = 27.0 GHz

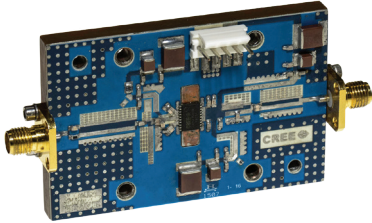

Product Ordering Information

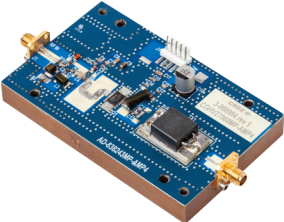
Order Number	Description	Unit of Measure	Image
CGHV27060MP	GaN HEMT	Each	
CGHV27060MP-AMP1	Test board with GaN HEMT installed	Each	
CGHV27060MP-AMP3	Test board with GaN HEMT installed	Each	
CGHV27060MP-AMP4	Test board with GaN HEMT installed	Each	



For more information, please contact:

4600 Silicon Drive
Durham, North Carolina, USA 27703
www.wolfspeed.com/rf

Sales Contact
rfsales@cree.com

Notes & Disclaimer

Specifications are subject to change without notice. “Typical” parameters are the average values expected by Cree in large quantities and are provided for information purposes only. Cree products are not warranted or authorized for use as critical components in medical, life-saving, or life-sustaining applications, or other applications where a failure would reasonably be expected to cause severe personal injury or death. No responsibility is assumed by Cree for any infringement of patents or other rights of third parties which may result from use of the information contained herein. No license is granted by implication or otherwise under any patent or patent rights of Cree.

© 2015 – 2021 Cree, Inc. All rights reserved. Wolfspeed® and the Wolfspeed logo are registered trademarks of Cree, Inc.