

SPECIFICATION

Part No.	: G24.A.W.305111
Product Name	: G24 Ultima Series – Super Low Profile Penta Band Cellular 800~960/1710~2170MHz Antenna Screw-mount GSM/GPRS/CDMA/HSPA (Permanent mount)
Feature	: Height 19.6mm(0.77") Diameter 55mm(2.16") Heavy duty screw mount UV and vandal resistant PC housing and thread IP67 compliant Standard is 3 meter low loss cable CFD200 SMA(M) White Housing Cables and Connectors Customizable ROHS Compliant

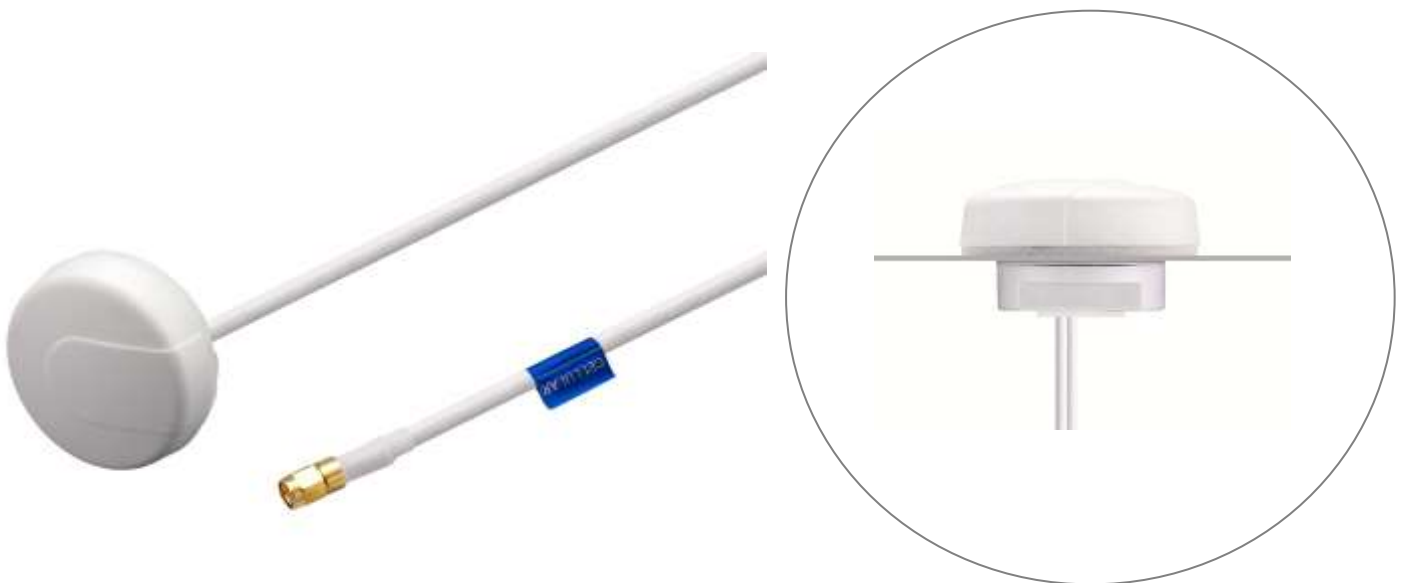

1. Introduction

G24.W Ultima Series Cellular Antenna is an extremely low profile 2G/3G 800MHz to 2200MHz cellular antenna solution for professional telematics applications. Suitable for GSM/GPRS/CDMA applications worldwide, at only 19.6mm (0.77") in height it is the lowest profile antenna in the market, with a diameter of only 55 mm (2.16"). It works well when mounted on both metal and non-metal. In other words it does not need a metal ground-plane to attach to, to radiate, something that competitor antennas all need. Taoglas recommend a minimum cable length of 70mm when used on a ground plane to achieve an efficiency of greater than 20%.

Durable UV PC housing, thread and nut is resistant to vandalism and direct attack.

The IP67 waterproof robust plastic body makes it extremely light, economical for shipping and minimum weight impact on vehicles. This also makes it ideal for use in humid environments such as water pits or marine applications as there are no metal parts to corrode. The closed cell foam with double-sided adhesive provides a permanent waterproof seal and can adjust to different curvatures, stopping water from leaking under the antenna into the mounting hole. Lowest loss PTFE cable is used for maximum gain and reduced noise entry through the cable.

Also available in Black.

2. Specification

CELLULAR					
Frequency (MHz)	824 ~ 896	880 ~ 960	1710 ~ 1880	1850 ~ 1990	1710 ~ 2170
Peak Gain (dBi)					
Free space	2.0	1.8	3.9	3.9	3.9
10x10mm ground plane	-0.6	0.7	-0.2	1.7	1.7
20x20mm ground plane	1.8	1.8	3.1	3.1	3.1
30x30mm ground plane	0.0	0.0	1.7	1.7	2.0
Average Gain (dBi)					
Free space	-4.1	-4.0	-2.7	-2.8	-2.7
10x10mm ground plane	-4.8	-3.3	-4.9	-4.0	-4.0
20x20mm ground plane	-4.3	-4.3	-4.2	-4.0	-4.0
30x30mm ground plane	-6.3	-6.6	-4.4	-4.4	-4.4
Efficiency (%)					
Free space	39.1	39.3	53.4	52.5	53.4
10x10mm ground plane	33.8	46.2	32.1	40.0	40.0
20x20mm ground plane	36.9	36.9	37.8	39.3	39.3
30x30mm ground plane	23.4	23.4	36.0	36.0	36.0
Polarization	Linear				
Radiation Pattern	Omni				
Input Power	50Ω				
MECHANICAL					
Dimensions	Φ55±2mm , Height 30±2 mm, Profile 19.6mm Ø2.16"; Height 1.18"; Profile 0.77"				
Cable type	CFD200				
Cable length	3000±30mm(9' 10 ¹ / ₈ "±1.18")				
Casing	PC				
Connector	SMA Male				
ENVIRONMENTAL					
Temperature Range	-40°C to 85°C				
Waterproof	IP-67				
Thermal Shock	100 cycles -40°C to +80°C				
Shock (drop test)	1m drop on concrete 6 axes				
Humidity	Non-condensing 65°C 95% RH				
Weight	180g				
Recommended Torque for Mounting	3.92N·m				
Max Torque for Mounting	4.9N·m				

3. Antenna Characteristics

3.1 Cellular antenna SWR

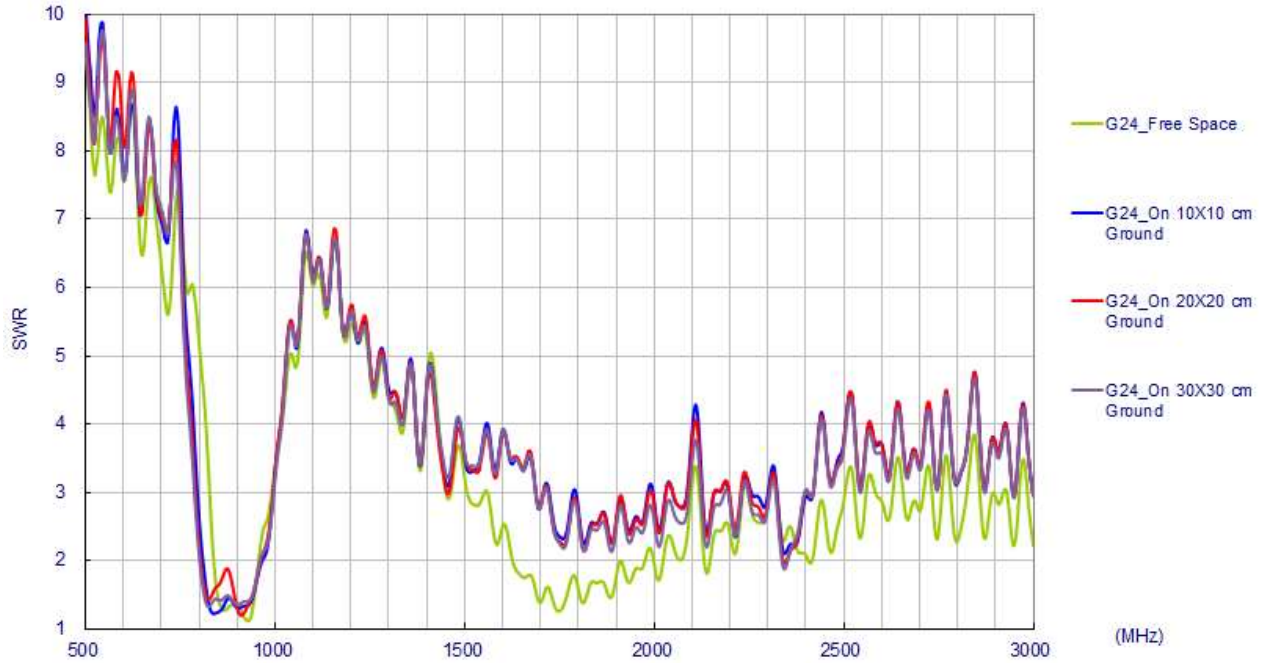

3.2 Antenna Efficiency

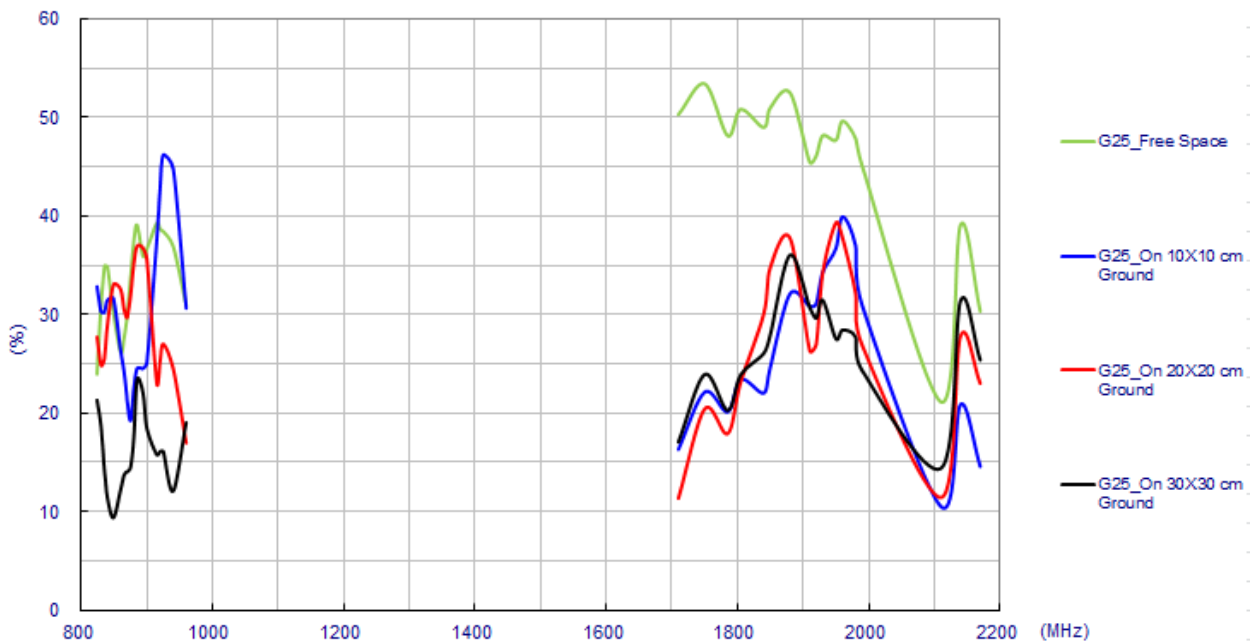

3.3 Peak Gain

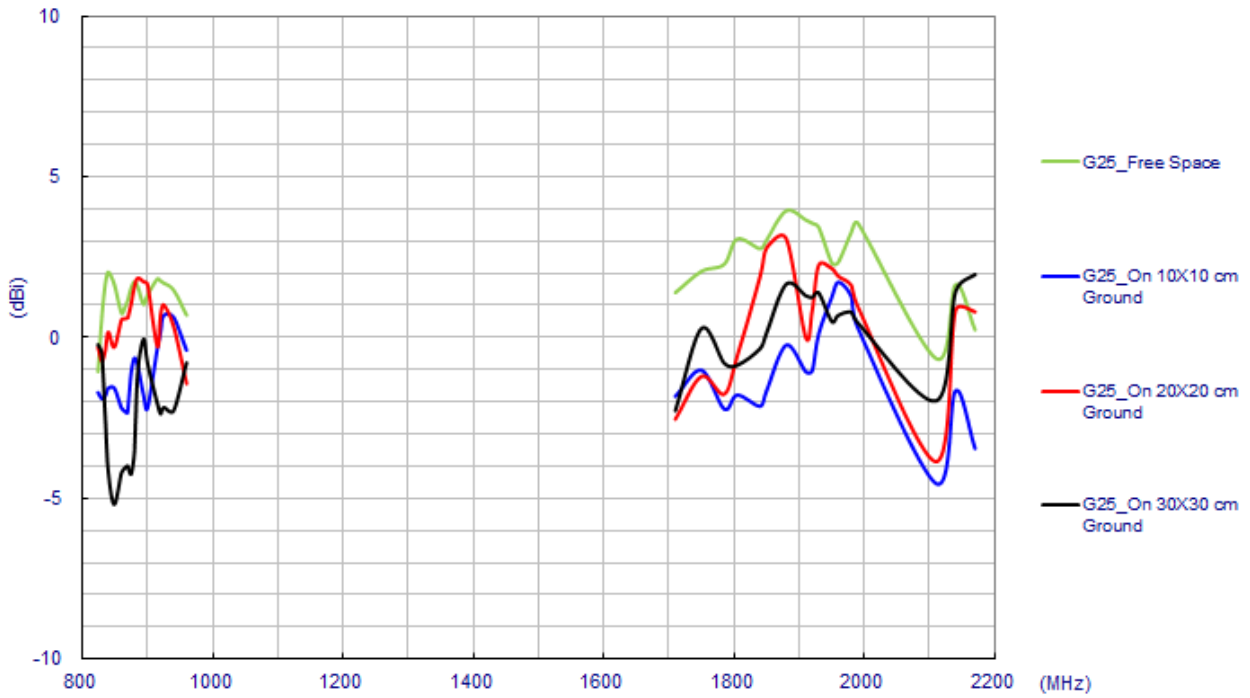

3.4 Average Gain

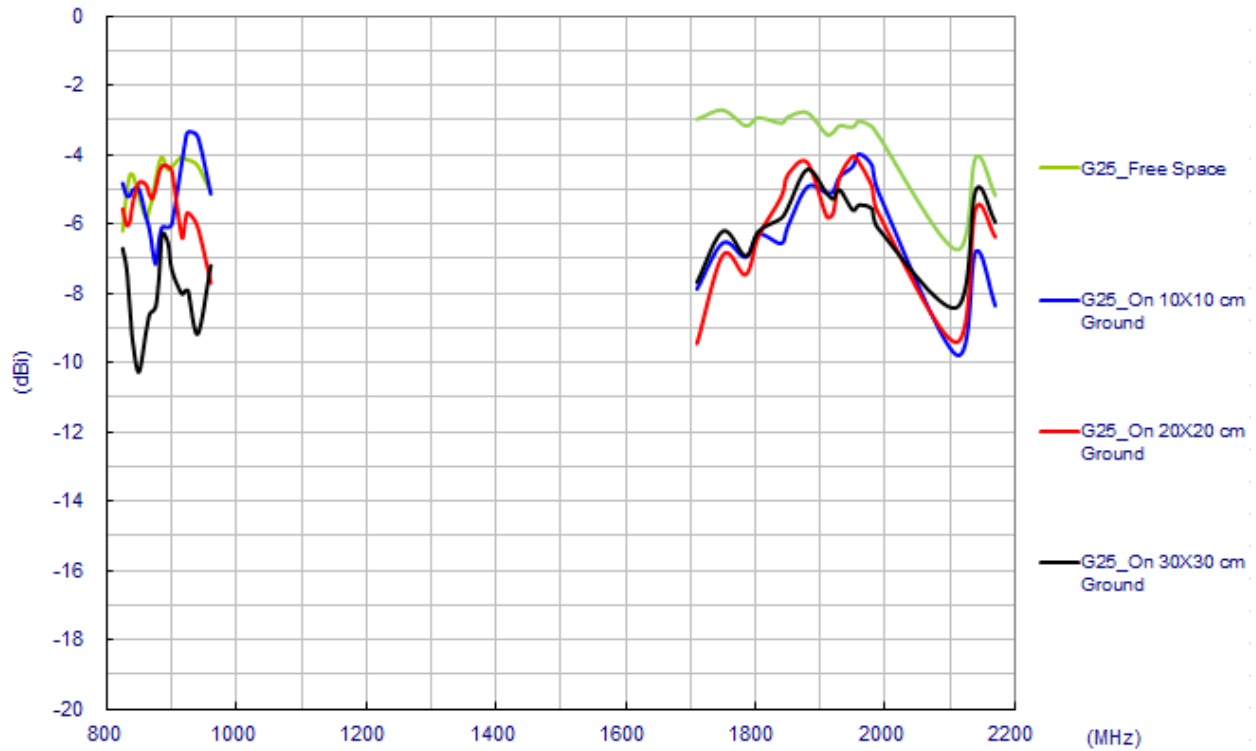

4 Antenna Radiation Pattern (Free Space)

4.1 Antenna Setup (Free Space)



4.2 Radiation Pattern (Free Space)

4.2.1 X-Y plane (dBi) (Free Space)

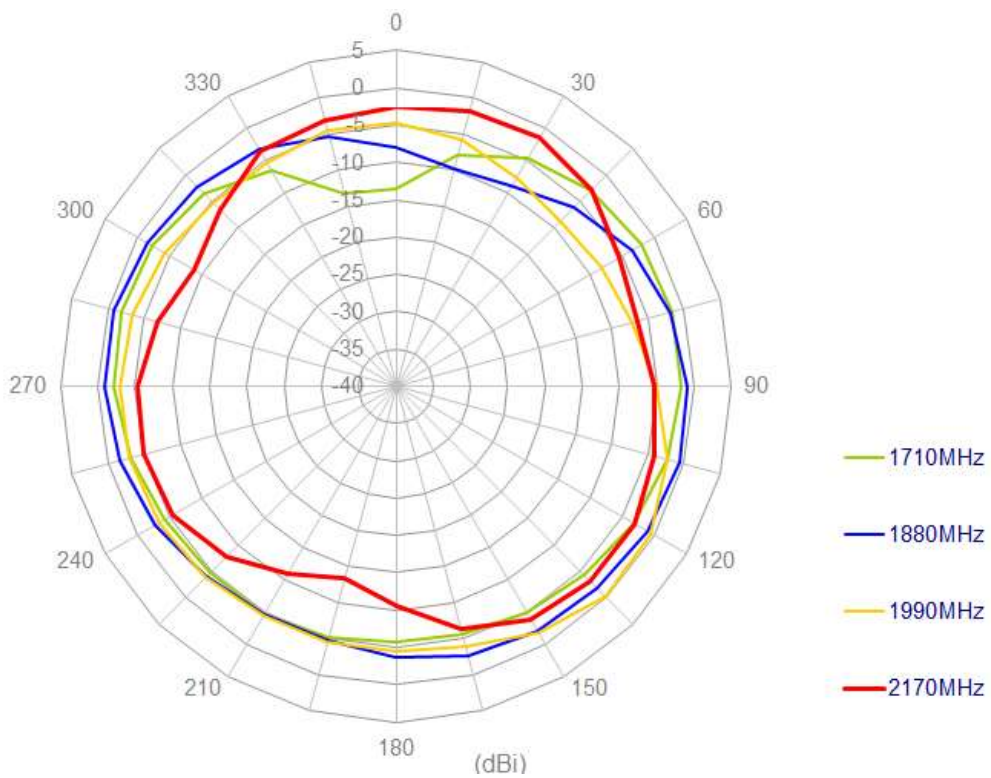
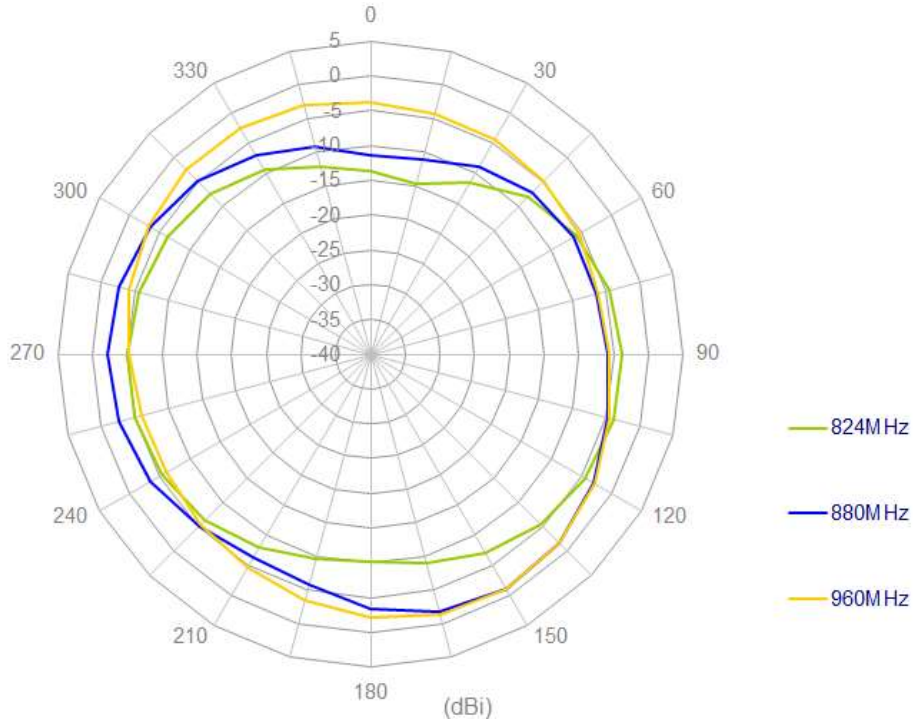

4.2.2 X-Z plane (dBi) (Free Space)

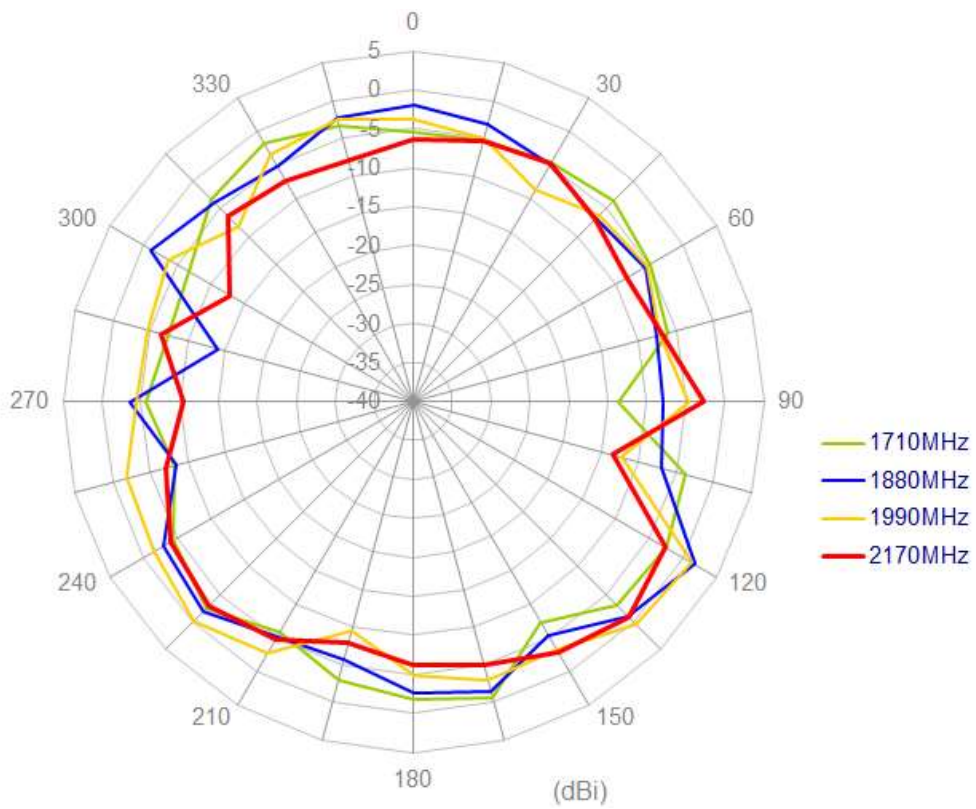
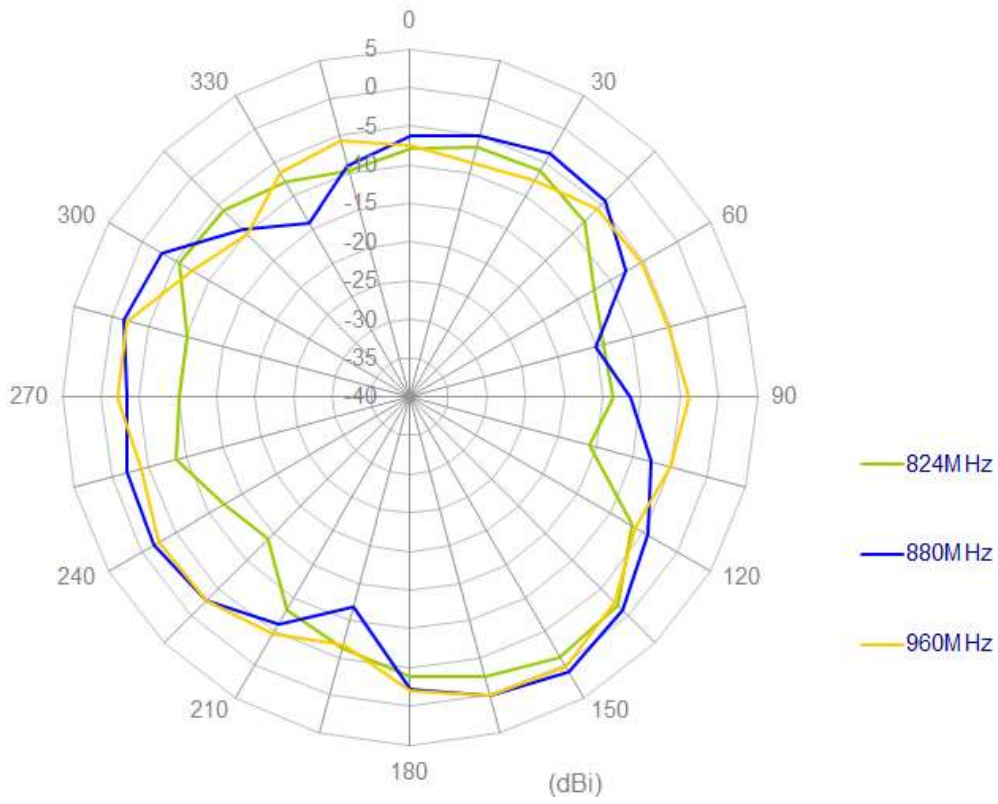

5 Antenna Radiation Pattern (10*10mm)

5.1 Antenna Setup (10*10mm Ground Plane)

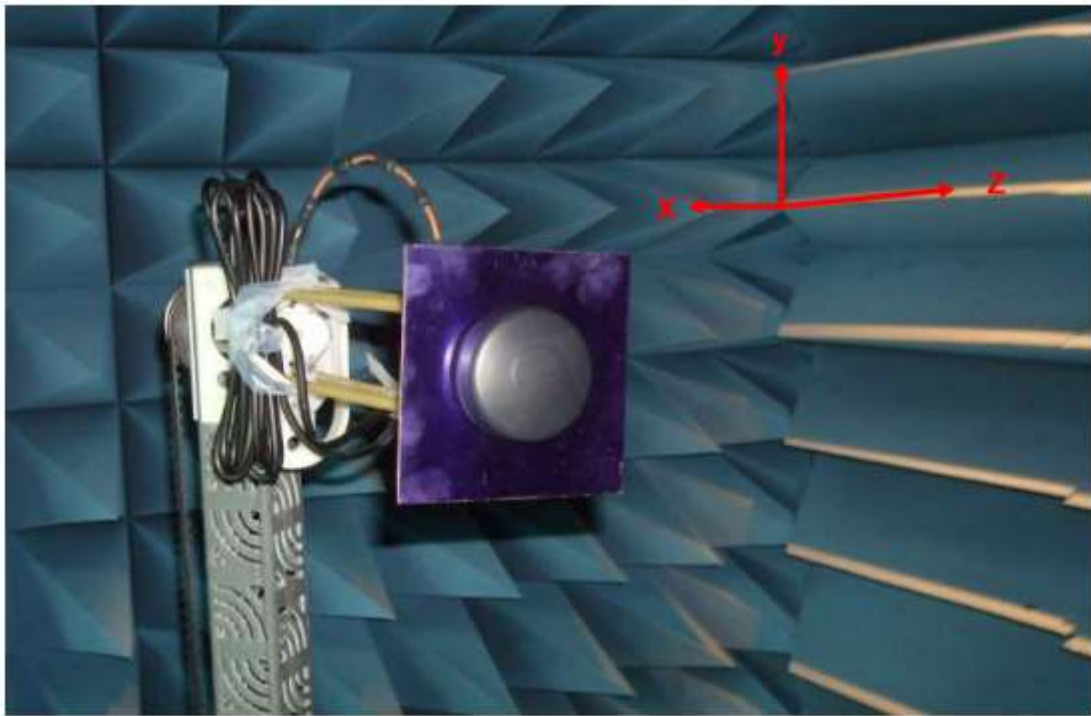

5.2 Radiation Pattern (10*10mm Ground Plane)

5.2.1 X-Y plane (dBi) (10*10mm Ground Plane)

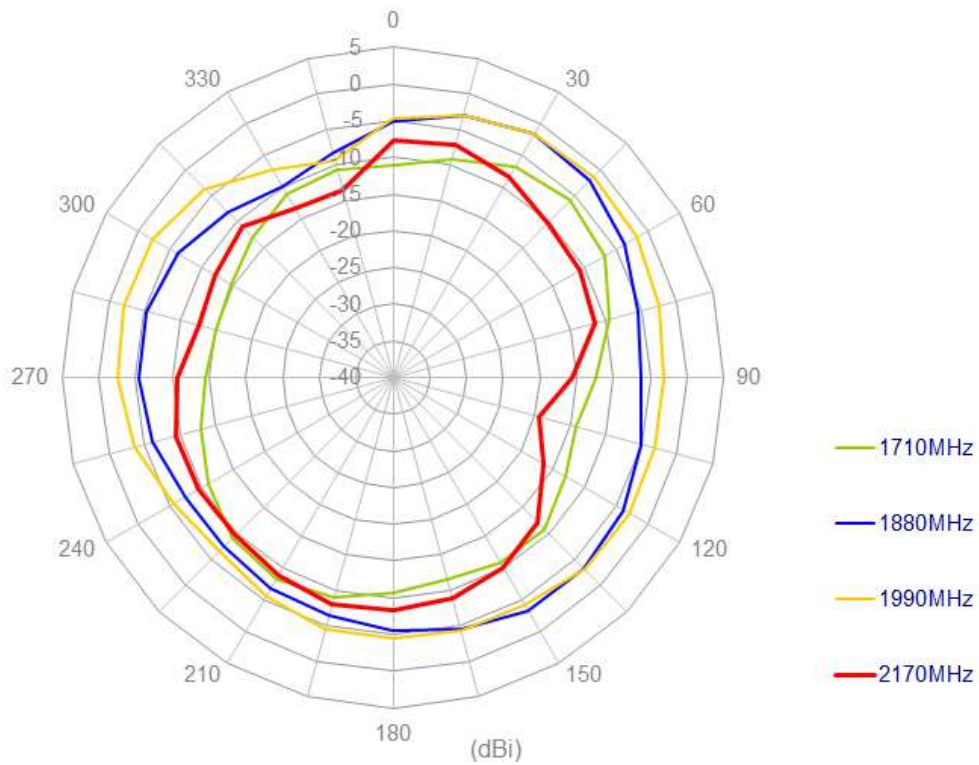
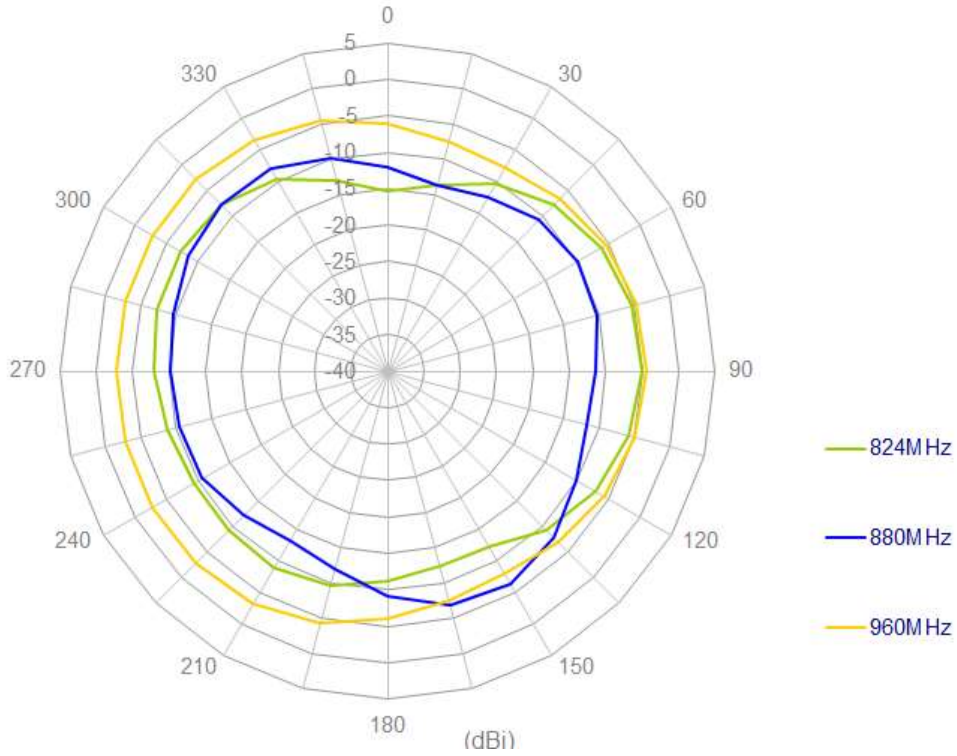

5.2.2 X-Z plane (dBi) (10*10mm Ground Plane)

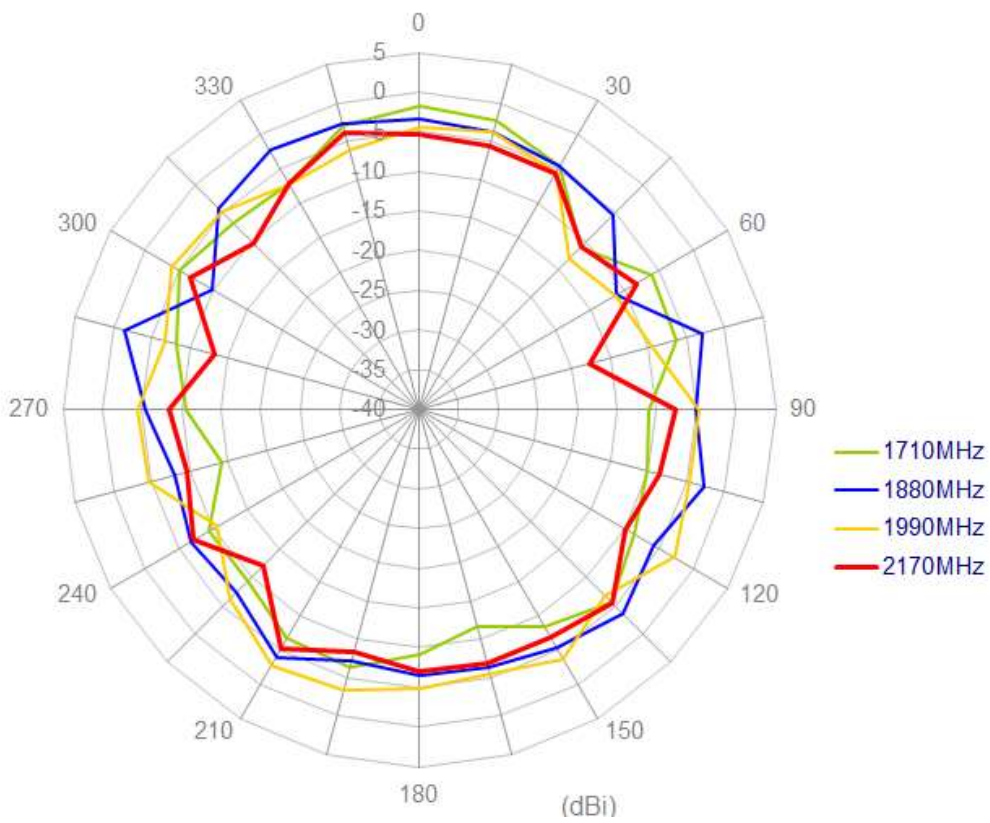
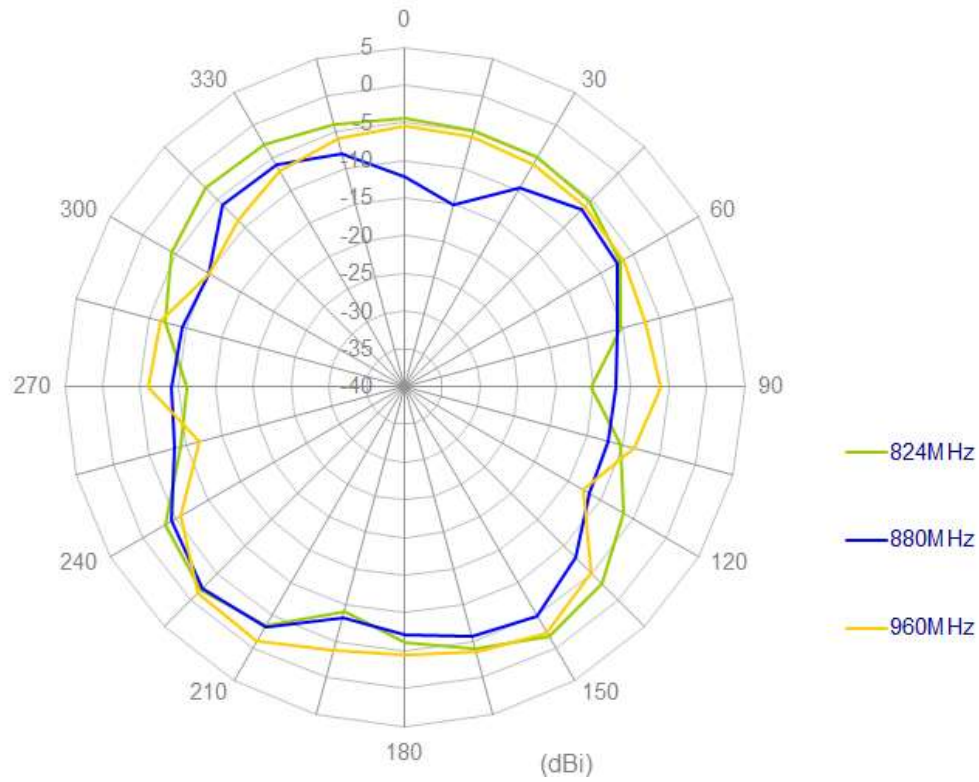

6 Antenna Radiation Pattern (20*20mm Ground Plane)

6.1 Antenna Setup (20*20mm Ground Plane)



6.2 Radiation Pattern (20*20mm Ground Plane)

6.2.1 X-Y plane (dBi) (20*20mm Ground Plane)

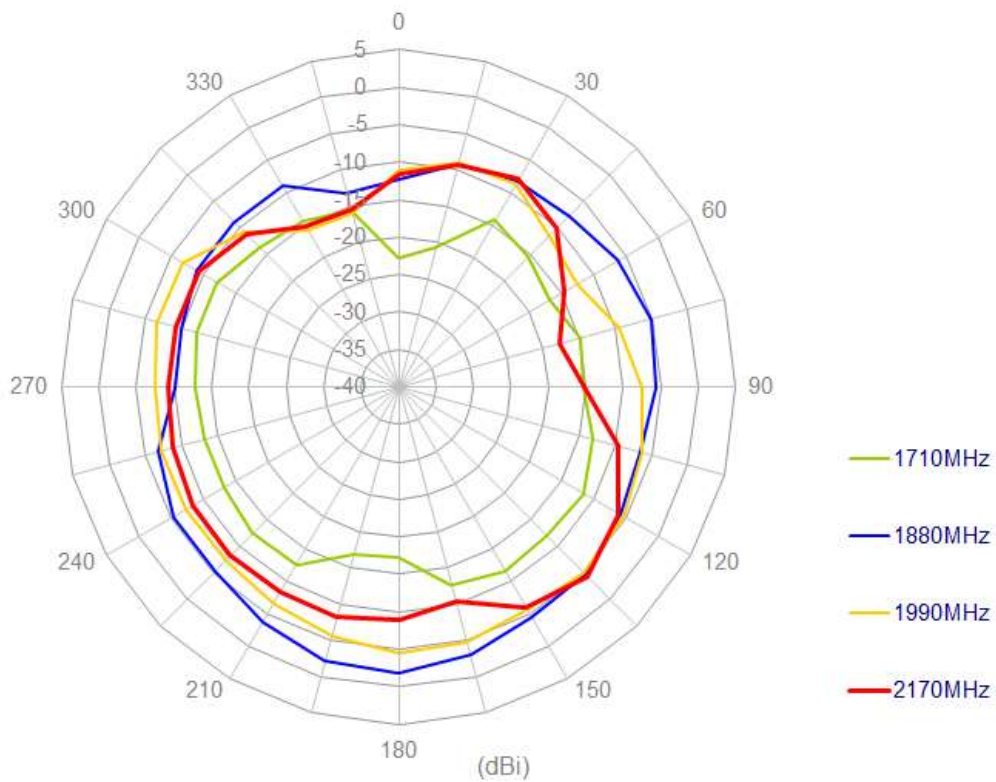
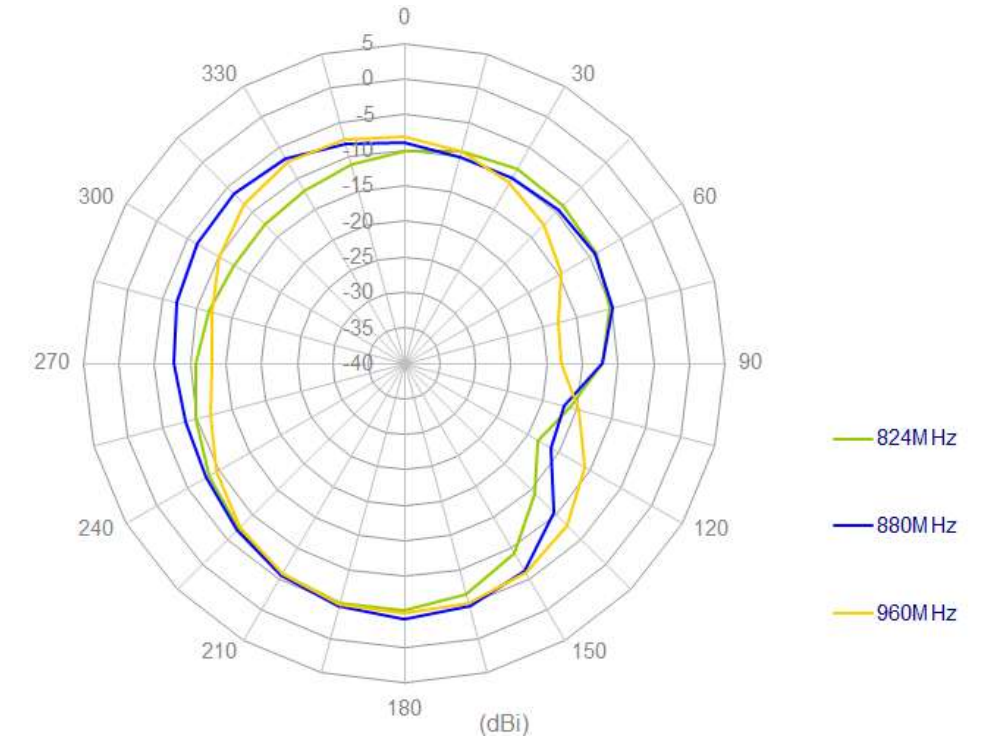

6.2.2 X-Z plane (dBi) (20*20mm Ground Plane)

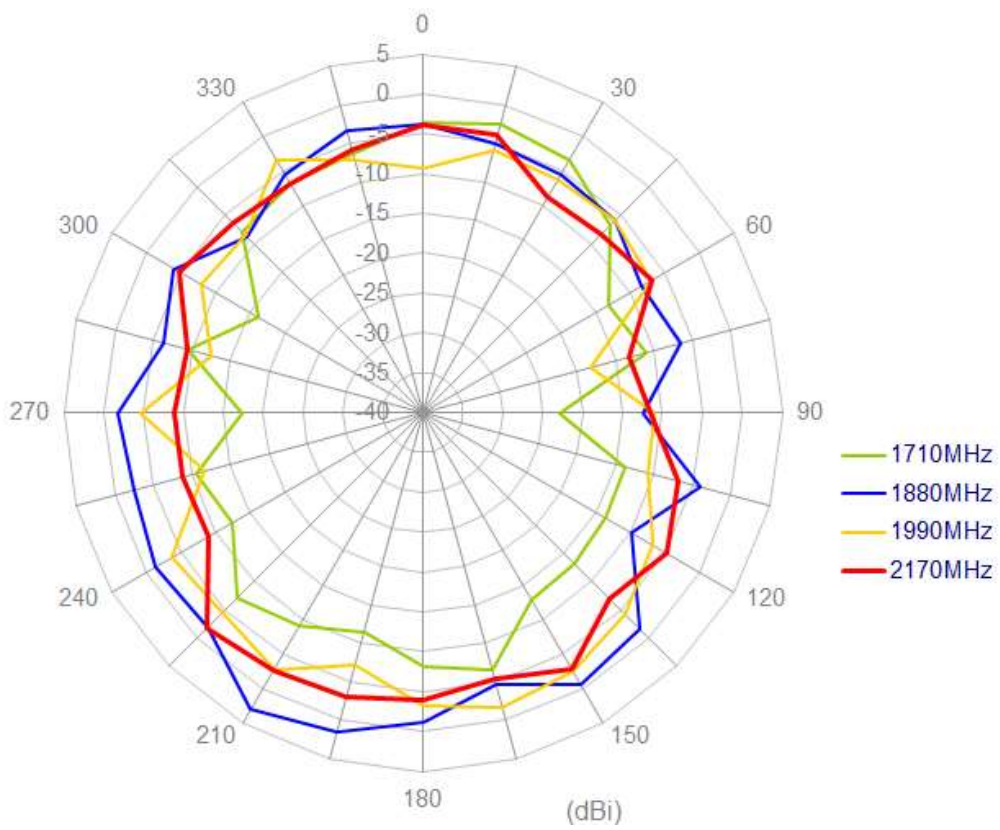
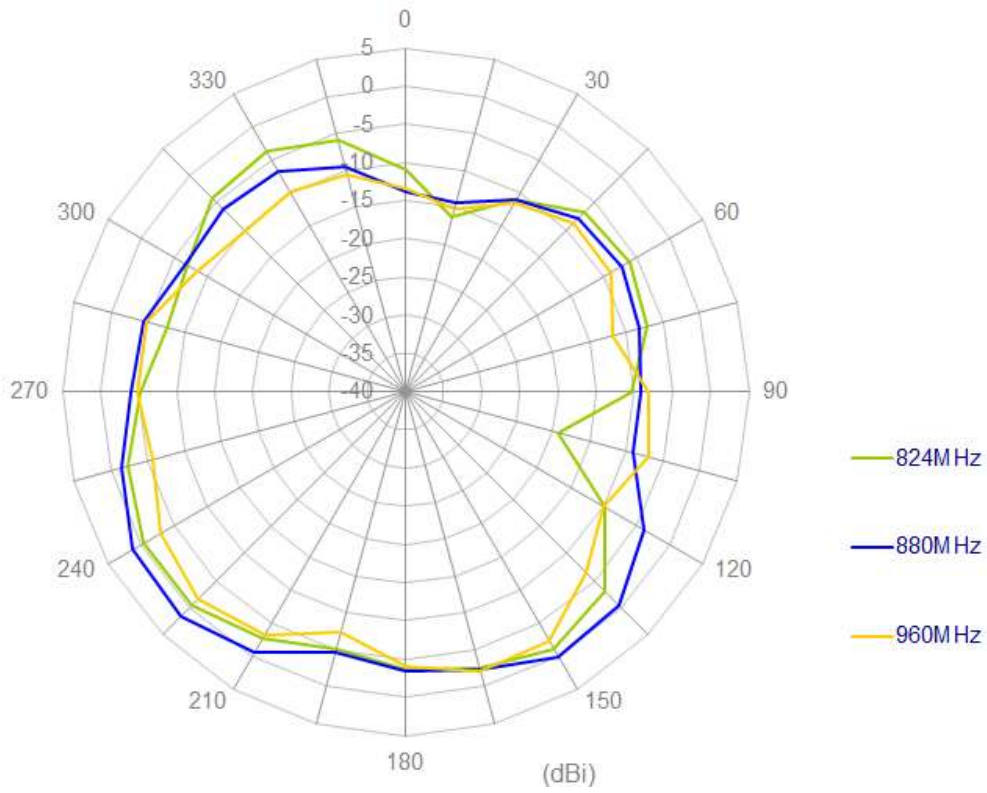

7 Antenna Radiation Pattern (30*30mm Ground Plane)

7.1 Antenna Setup (30*30mm Ground Plane)

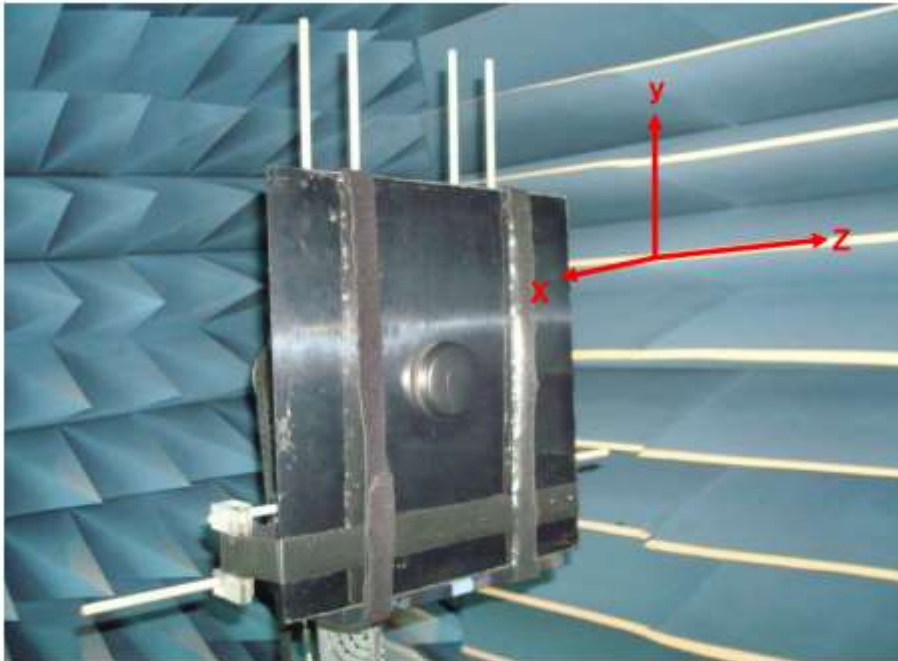

7.2 Radiation Pattern (20*20mm Ground Plane)

7.2.1 X-Y plane (dBi) (20*20mm Ground Plane)

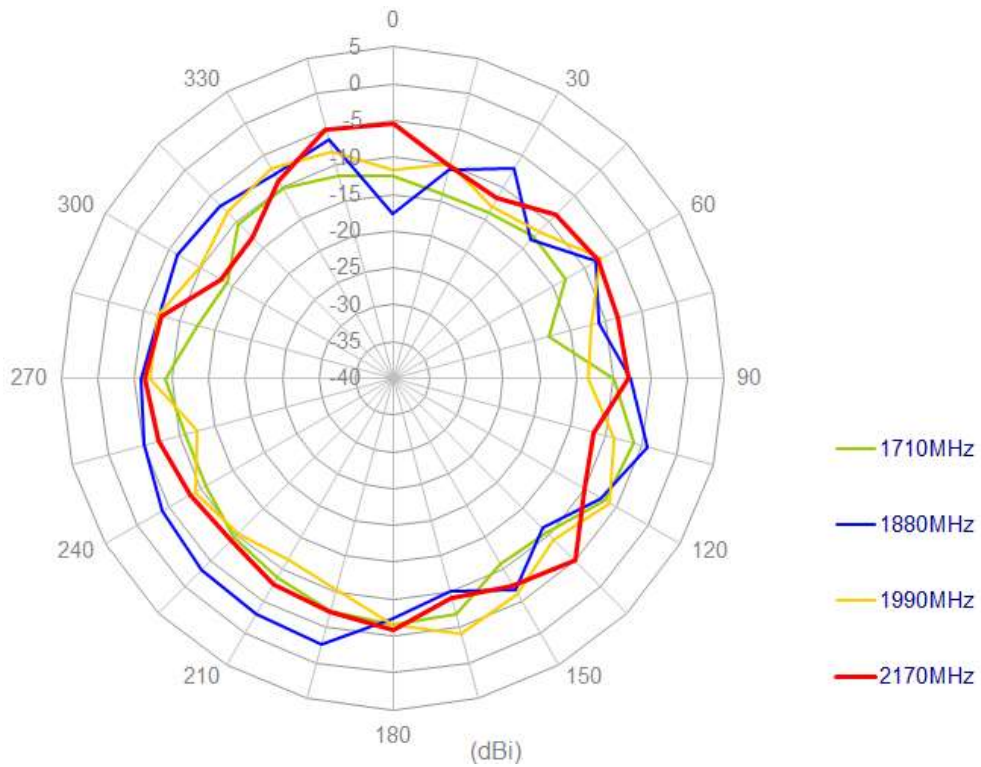
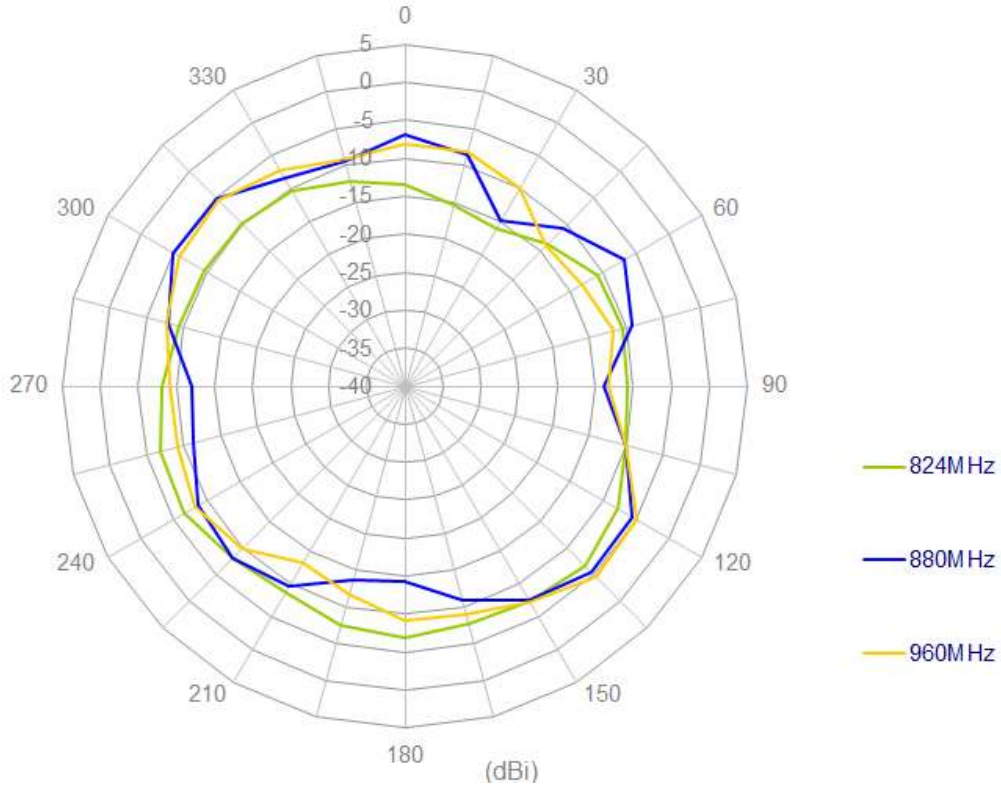

7.2.2 X-Z plane (dBi) (20*20mm Ground Plane)

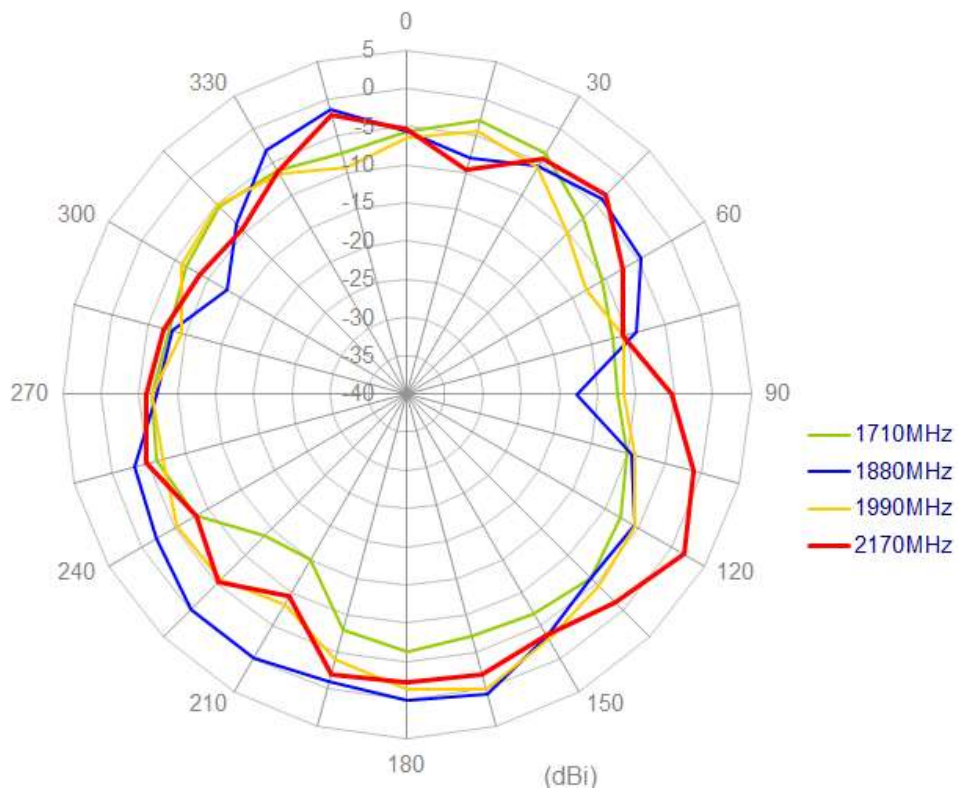
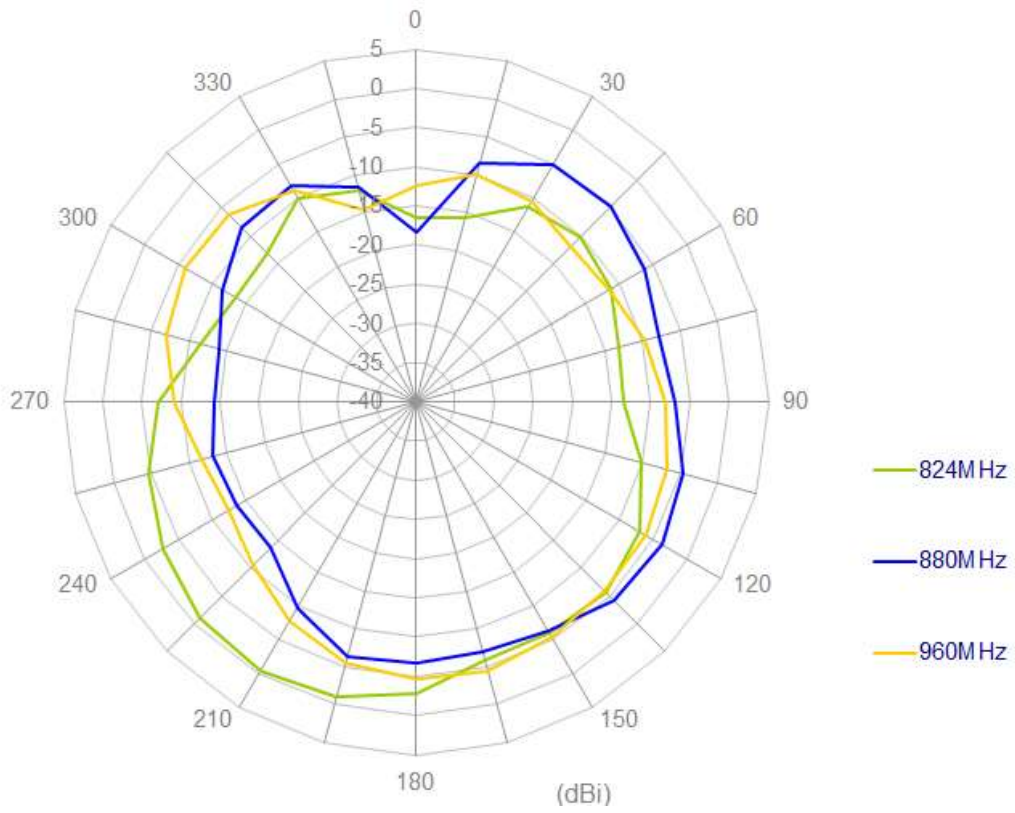

8 Installation

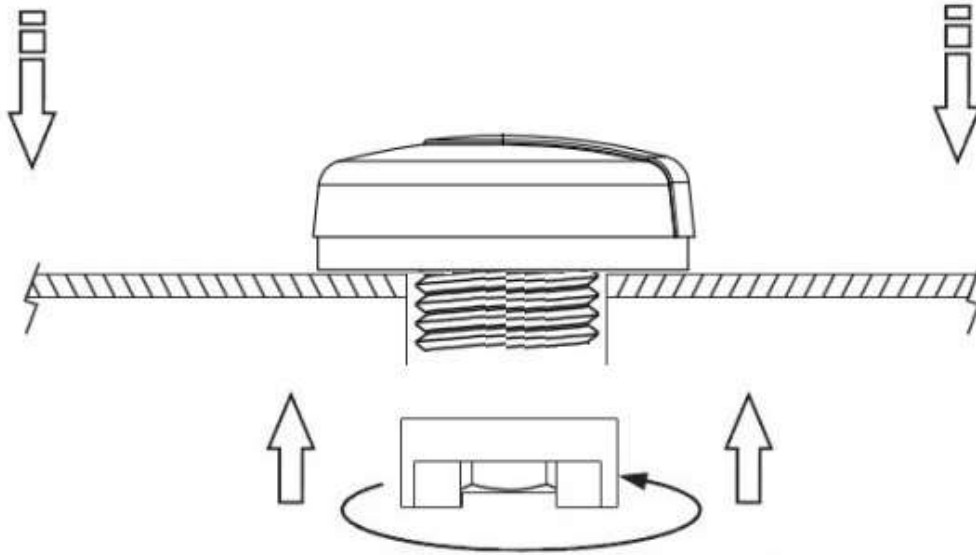

Recommended torque for Mounting is 3.92N·m
 Maximum torque for Mounting is 4.9N·m

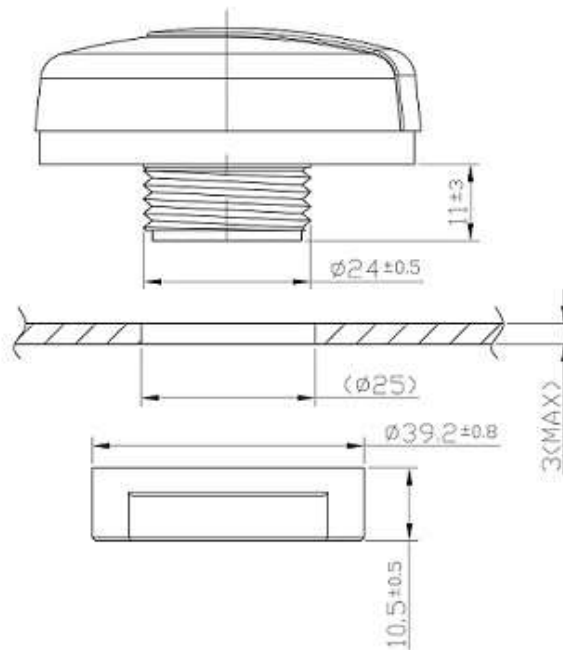

9 Drawing

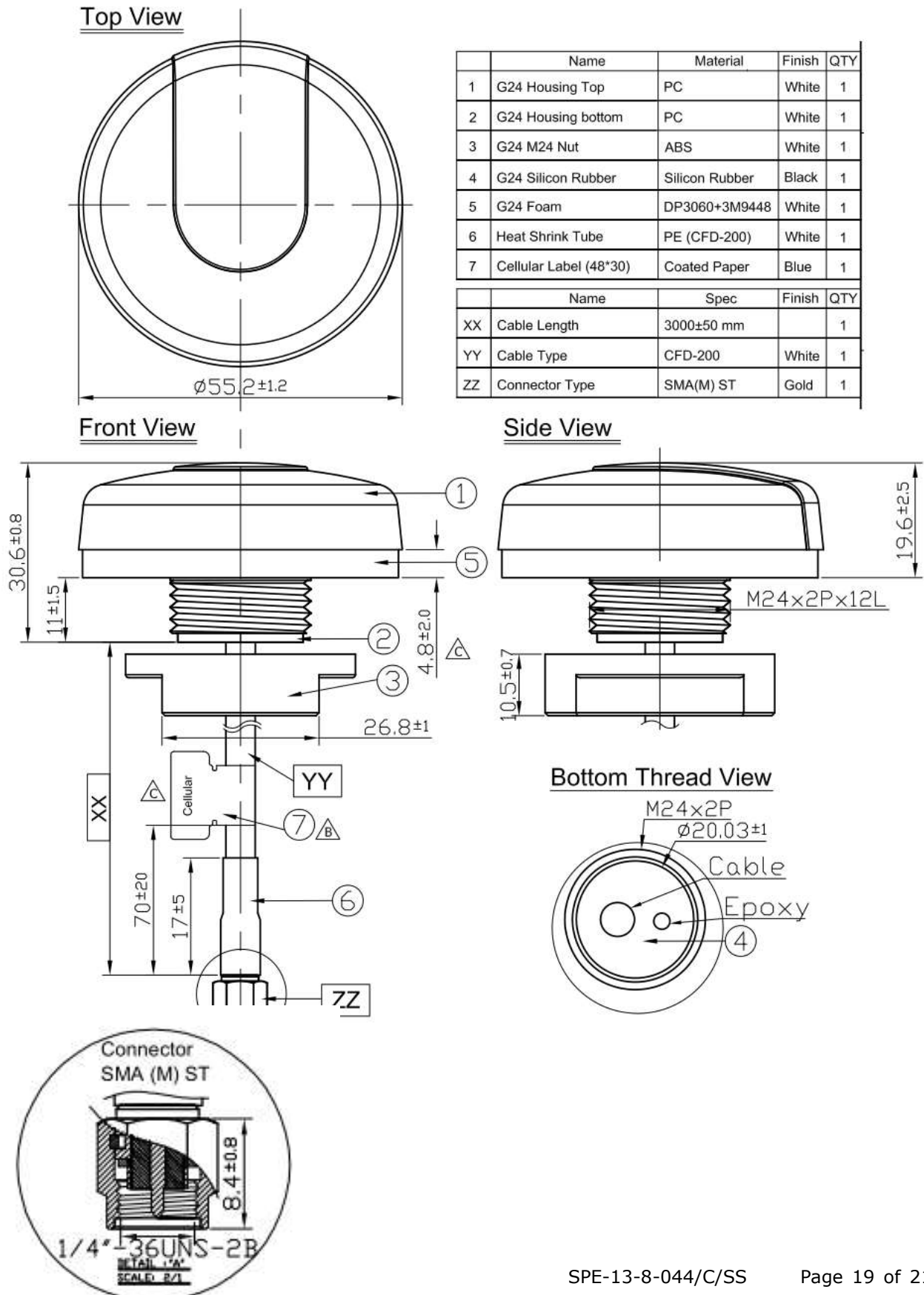

10. Packaging

1 piece G24 per PE Bag
Weight 180g

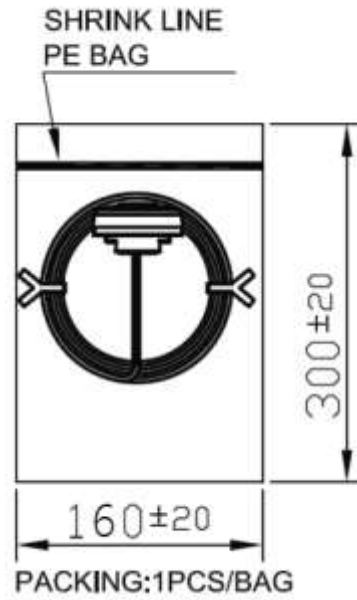

50 pieces per carton
Weight 10kg

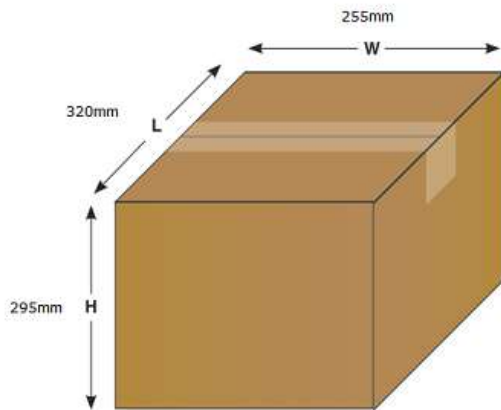

60 Cartons per Pallet
Pallet Dims 110cm*110cm
3000 pcs per pallet

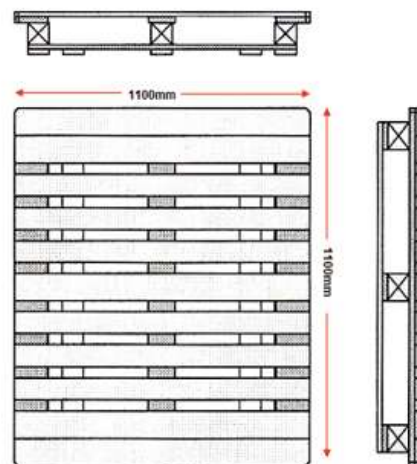

10 Application Note

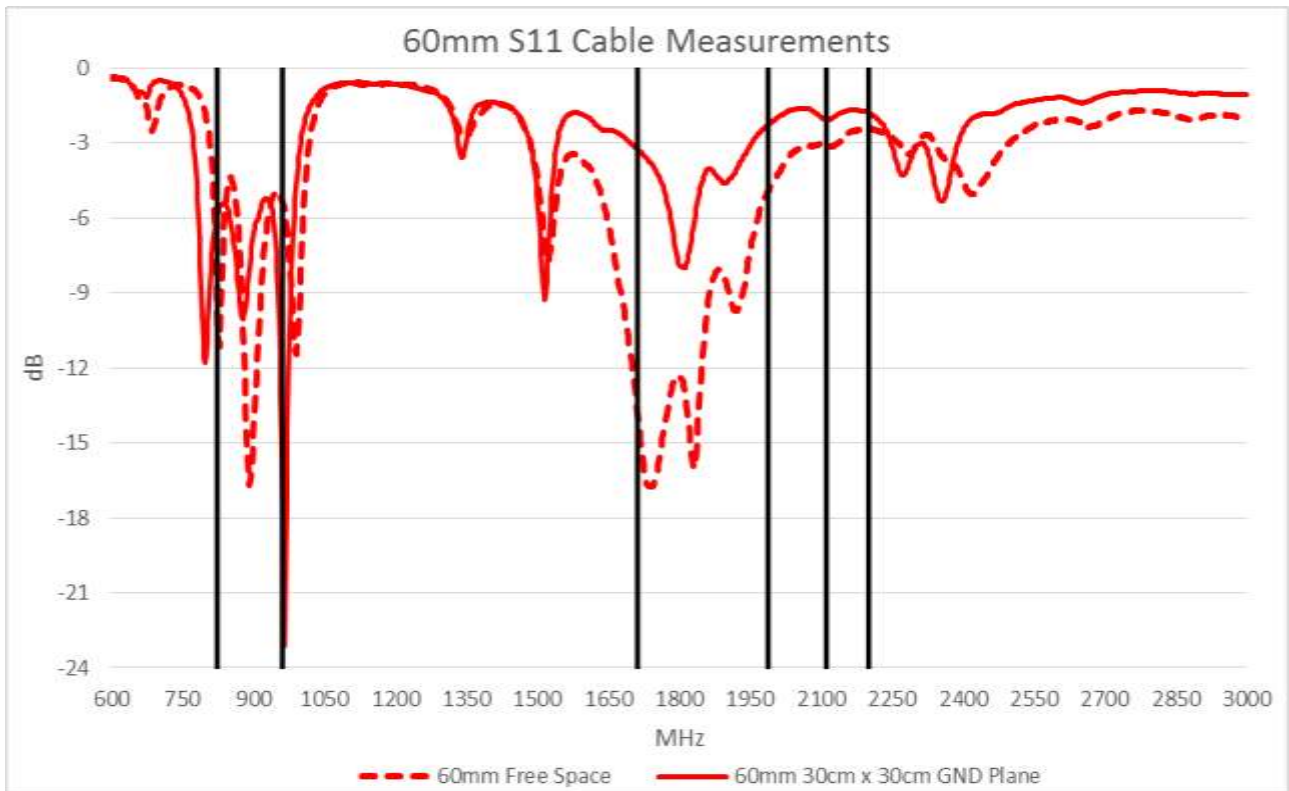

Taoglas recommend a minimum cable length of 60mm for this antenna when used on a ground plane to achieve an efficiency of greater than 20%.

The poor return loss (see graph above) when used on a ground plane is a function of such a small antenna. The complete system will still operate, though there may be some extra energy used in the system to compensate for the power losses.