



# CFM60T SERIES

## 60W TRIPLE OUTPUT AC-DC MODULES



### Features

- \* Universal Input: 90~264Vac
- \* 2" x 4" Size
- \* Industry-Standard Pin Out
- \* Efficiency to 83%
- \* Meets EN61204-3 Class B and CISPR/FCC Class B
- \* Short Circuit Protection

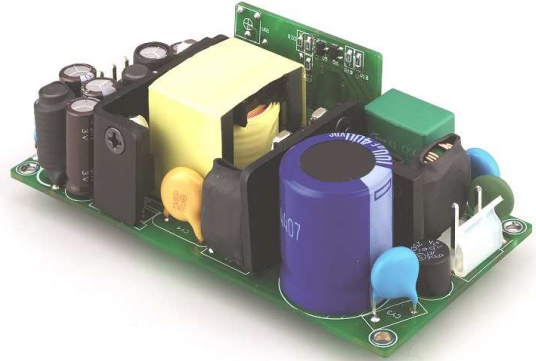

MODEL	Output Voltage	Output Current(A)			Ripple (mVp-p)	Voltage Accuracy	Line Reg.	Load Reg.	O/P Power Max.	% EFF. (Typ.)
		Min.	Rated	Max.						
CFM60T-01	V1=5V	0A	4.0A	5.0A	50mV	±2%	±1%	±4%	62W	83%
	V2=12V	0A	3.0A	3.7A	120mV	±5%	±1%	±3%		
	V3=-12V	0A	0.5A	0.65A	120mV	±5%	±1%	±5%		
CFM60T-02	V1=5V	0A	4.0A	5.0A	50mV	±2%	±1%	±4%	62W	83%
	V2=15V	0A	2.5A	3.1A	150mV	±4%	±1%	±3%		
	V3=-15V	0A	0.3A	0.5A	150mV	±5%	±1%	±5%		
CFM60T-03	V1=5V	0A	4.0A	5.0A	50mV	±2%	±1%	±4%	62W	83%
	V2=24V	0A	1.5A	1.8A	240mV	±3%	±1%	±3%		
	V3=-12V	0A	0.5A	0.6A	120mV	±5%	±1%	±5%		
CFM60T-04	V1=3.3V	0A	6.0A	7.5A	50mV	±4%	±1%	±5%	40.8W	78%
	V2=5V	0A	3.0A	3.7A	50mV	±5%	±1%	±4%		
	V3=-12V	0A	0.5A	0.65A	120mV	±5%	±2%	±5%		

## Specifications

### INPUT SPECIFICATIONS:

Voltage	90~264Vac
Frequency	47 to 63Hz
Inrush Current	Cold Start@25°C 50A max. @240Vac
Leakage Current	3.5mA max.

### OUTPUT SPECIFICATIONS:

Holdup Time	8ms typ. @115Vac
Short Circuit	Hiccup Mode (Auto Recover)
Over Voltage Protection	6V/7V on V1(3.3V/5V) 15V/18V/28V on V2(12V/15V/24V)
Temperature Coefficient	±0.05%/°C

### GENERAL SPECIFICATIONS:

Isolation	Input to output = 4,242VDC
Operating Temperature	0 ~ 60°C (see Derating Curve)
Storage Temperature	-20 ~ 85°C
Humidity	93% RH max. Non-Condensing
Cooling	Natural Convection
Switching Frequency	65KHz Typical
MTBF	MIL-HDBK-217F, GB, 25°C/115VAC ..... T.B.D hrs
Altitude	2000m
Dimensions	4.000x2.000x1.260Inches (101.60x50.80x32.00mm)
Weight	170g (0.37 Pounds)

### SAFETY AND EMC:

Emission and Immunity	EN55032 Class B, FCC Part 15 Class B EN61000-3-2, EN61000-3-3, EN55024
Safety	IEC60950-1, EN60950-1, UL60950-1

## CFM60T Series Derating Curve

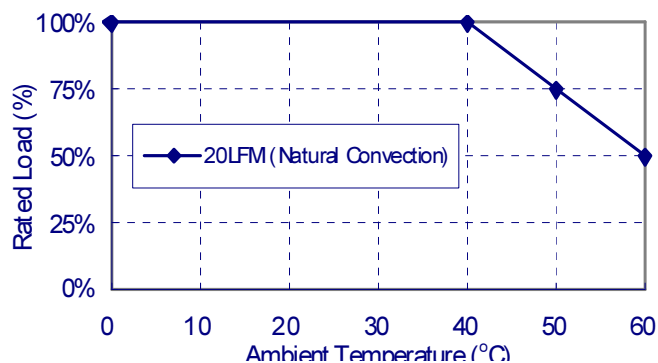

### NOTE:

- Voltage accuracy is set of 60% rated load.
- Add a 0.1uF ceramic capacitor and a 10uF E.L. capacitor to output for Ripple & Noise measuring @20MHz BW.
- Line regulation is measured from 103Vac~127Vac & 207Vac~253Vac with rated load.
- Load regulation is defined by changing ±40% of measured output load from 60% rated load at other outputs set to 60% rated load.
- Input connector mates with Molex housing 09-50-3031 and Molex 2878 series crimp terminal.
- Output connector mates with Molex housing 09-50-3061 and Molex 2878 series crimp terminal.

## CFM60T Series

All Dimensions in Inches[mm]  
Tolerance Inches:x.xxx±0.02  
Millimeters:x.xx±0.5

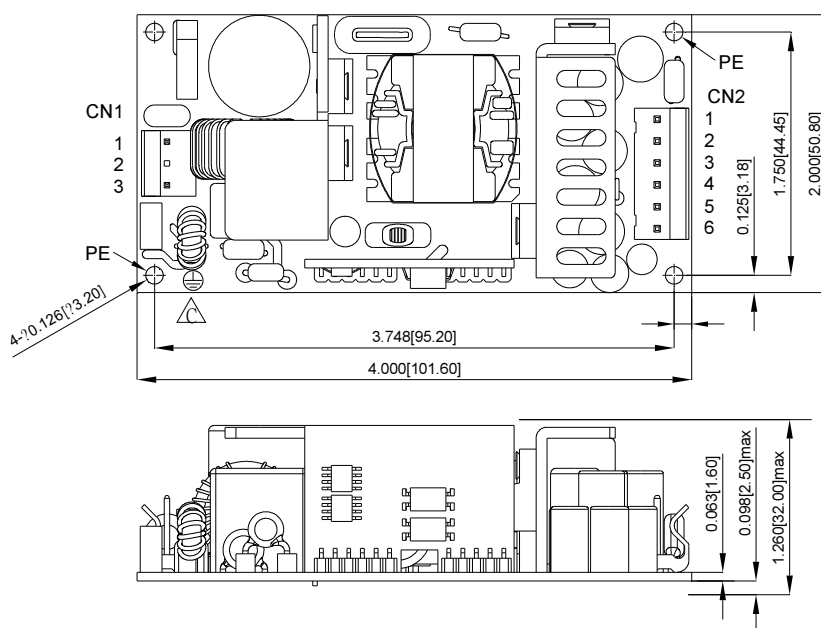

CN1:

PIN CONNECTION	
Pin	Function
1	Neutral
2	Not Fitted
3	Line

CN2:

PIN CONNECTION	
Pin	Function
1	V2
2	V1
3	V1
4	GND
5	GND
6	V3

Typical at 25°C, nominal line and 75% load, unless otherwise Specified