



7A VI Chip® EMI Filter SiP

Product Description

The QPI-12 EMI filter is specifically designed to attenuate conducted common-mode (CM) and differential-mode (DM) noise of Vicor VI Chip® products, such as the PRM™, VTM™ and BCM® converters, to comply with the CISPR22 standard requirements for conducted noise measurements. The filter is designed to operate up to 80V_{DC}, 100V_{DC} surge, and supports 7A loads up to 85°C (T_A) without de-rating.

Designed for the telecom bus range, the VI Chip EMI filter supports the PICMG® 3.0 specification for filtering system boards to the EN55022 Class B limits.



Features & Benefits

- 45dB CM attenuation at 1MHz (50Ω)
- 75dB DM attenuation at 1MHz (50Ω)
- 80V_{DC} (max input)
- 100V_{DC} surge 100ms
- 1,500V_{DC} hipot hold off to shield plane
- 7A rating
- Low-profile LGA package
- ~1/2in² area
- -40 to +125°C PCB temperature (see Figure 6)
- Efficiency >99%
- TÜV Certified

Applications

- VI Chip Input EMI Filter
- Telecom and ATCA boards

Package Information

- 12.9 x 25.3 x 5.0mm, lidded SiP (System-in-Package)
- 12.4 x 24.9 x 4.09mm, open-frame

Typical Applications

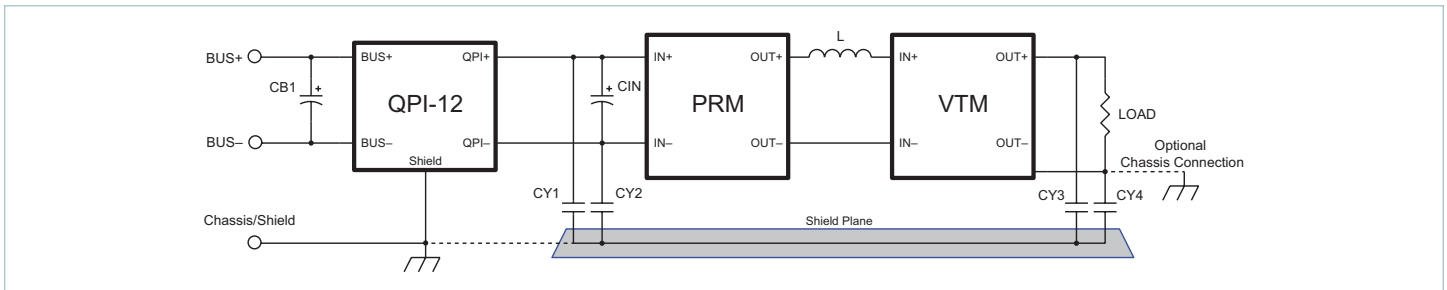

Typical QPI-12 application schematic with Vicor PRM and VTM modules^[a]

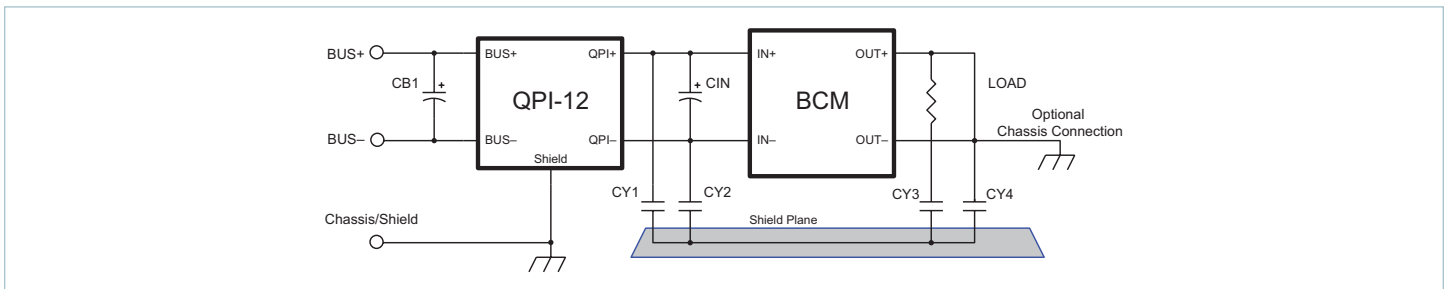

Typical QPI-12 application schematic with Vicor BCM module^[a]

^[a] CB1 capacitor, referenced in all schematics, is a 47μF electrolytic; United Chemi-Con EMVE101ARA470MKE0S or equivalent.
CY1 to CY4, referenced in all schematics, are 4.7nF high-voltage safety capacitors; Vishay VY1472M63Y5UQ63V0 or equivalent.

Contents

Order Information	3
Absolute Maximum Ratings	3
Electrical Characteristics	3
Package Pinout	4
Applications Information	5
EMI Sources	5
EMI Filtering	5
EMI Management	6
Attenuation Test Set Ups	6
Attenuation Plots	7
Current De-Rating	9
Converter Output Grounding	10
QPI Insertion Loss Measurements and Test Circuits	11
Package Outline Drawings	12
Pad and Stencil Definitions	13
PCB Layout Recommendations	14
PCB Layout	14
Post-Solder Cleaning	14
QPI-12 Mechanical Data	14
Product Warranty	15

Order Information

Product	Description
QPI-12LZ ^[b]	QPI-12 LGA package, RoHS compliant
QPI-12LZ-01	QPI-12 LGA package, RoHS compliant, open-frame package
Evaluation Board	Description
QPI-12-CB1	A QPI-12LZ mounted on a carrier board that can hold either a standalone BCM [®] or a paired PRM [™] /VTM [™] evaluation board available from Vicor.

^[b] QPI-12LZ is a non-hermetically sealed package. Please read the “Post-Solder Cleaning” section on page 13.

Absolute Maximum Ratings

Exceeding these parameters may result in permanent damage to the product.

Name	Rating
Input Voltage, BUS+ to BUS–, Continuous	–80 to 80V _{DC}
Input Voltage, BUS+ to BUS–, 100ms Transient	–100 to 100V _{DC}
BUS+ / BUS– to Shield Pads, Hi-pot	–1500 to 1500V _{DC}
Input to Output Current, Continuous @ 25°C (T _A)	7A _{DC}
Power Dissipation, @ 85°C (T _A), 7A ^[c]	1.85W
Operating Temperature - T _A	–40 to 125°C
Thermal Resistance ^[c] - R _{θJ-A} , using PCB layout in Figure 22	30°C/W
Thermal Resistance ^[c] - R _{θJ-PCB}	18°C/W
Storage Temperature, JEDEC Standard J-STD-033B	–55 to 125°C
Reflow Temperature, 20s Exposure	245°C
ESD, Human Body Model (HBM)	–2000 to 2000V

Electrical Characteristics

Parameter limits apply over the operating temperature range unless otherwise noted.

Parameter	Conditions	Min	Typ	Max	Unit
BUS+ to BUS– Input Range	Measured at 7A, 85°C ambient temperature ^[c]			80	V _{DC}
BUS+ to QPI+ Voltage Drop	Measured at 7A, 85°C ambient temperature ^[c]			130	mV _{DC}
BUS– to QPI– Voltage Drop	Measured at 7A, 85°C ambient temperature ^[c]			130	mV _{DC}
Common-Mode Attenuation	V _{BUS} = 48V, Frequency = 1.0MHz, line impedance = 50Ω	45			dB
Differential-Mode Attenuation	V _{BUS} = 48V, Frequency = 1.0MHz, line impedance = 50Ω	75			dB
Input Bias Current at 50V	Input current from BUS+ to BUS–			10	μA

^[c] See Figure 11 for the current de-rating curve.

Package Pinout

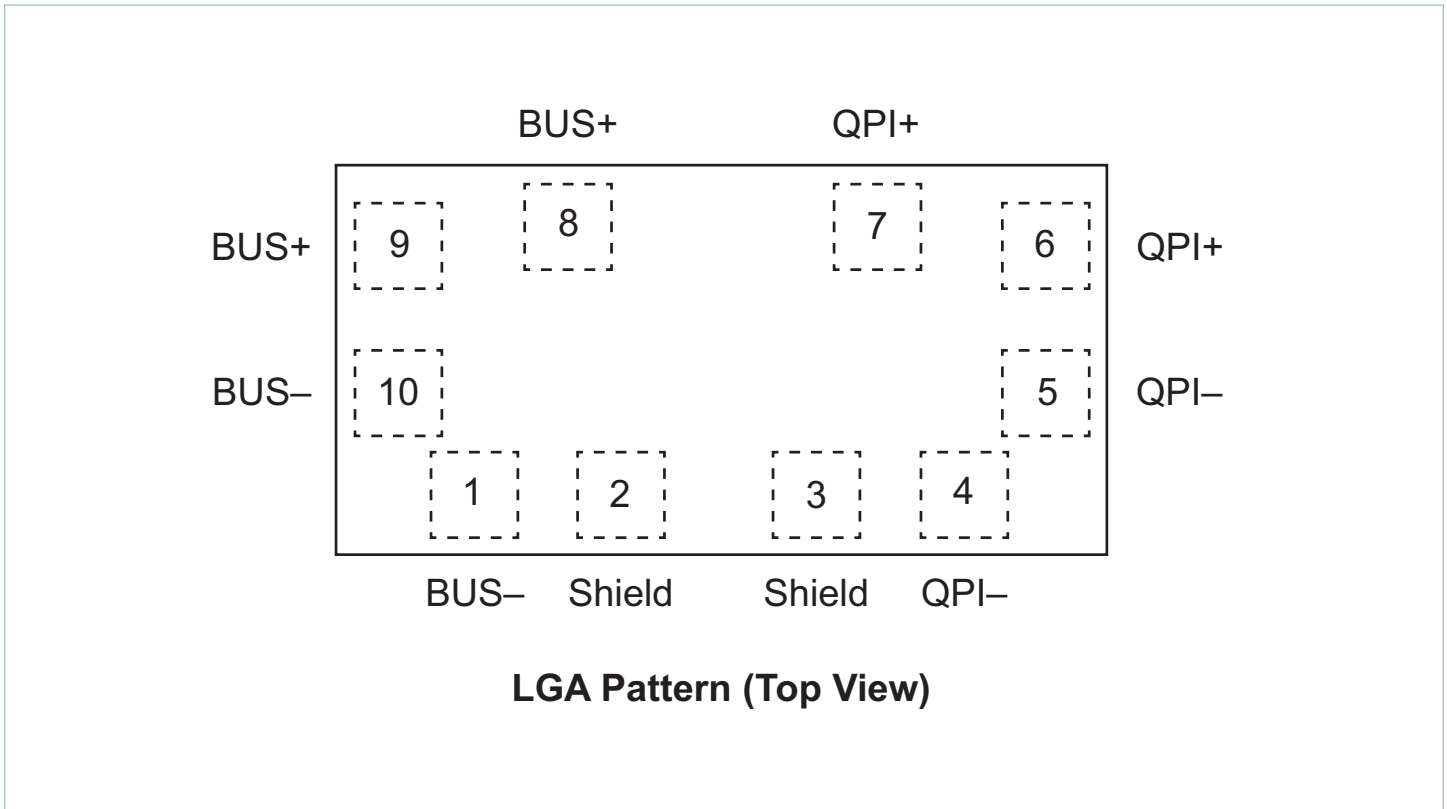

Pad Number	Name	Description
8, 9	BUS+	Positive bus potential
1, 10	BUS-	Negative bus potential
6, 7	QPI+	Positive input to the converter
4, 5	QPI-	Negative input to the converter
2, 3	Shield	Shield connects to the system chassis or to a safety ground

Applications Information

EMI Sources

Many of the components in today's power conversion modules are sources of high-frequency EMI noise generation. Diodes, high-frequency switching devices, transformers and inductors, and circuit layouts passing high dV/dt or dI/dt signals are all potential sources of EMI.

EMI is propagated either by radiated or conductive means. Radiated EMI can be sourced from these components as well as by circuit loops that act like antennas and broadcast the noise signals to neighboring circuit paths. This also means that these loops can act as receivers of a broadcasted signal. This radiated EMI noise can be reduced by proper circuit layout and by shielding potential sources of EMI transmission.

There are two basic forms of conducted EMI that typically need to be filtered; namely common-mode (CM) and differential-mode (DM) EMI. Differential-mode resides in the normal power loop of a power source and its load; where the signal travels from the source to the load and then returns to the source. Common-mode is a signal that travels through both leads of the source and is returned to earth via parasitic pathways, either capacitively or inductively coupled.

Figures 3 – 10 are the resulting EMI plots of the total noise, both common and differential mode, of Vicor PRM™/VTM™ and BCM® evaluation modules, under various loads, after filtering by the QPI-12LZ. The red and blue traces represent the positive and negative branches of total noise, as measured using an industry-standard LISN set up, shown in Figures 1 and 2. The PRM and VTM evaluation boards are mounted to a Vicor QPI-12-CB1 board for testing. The QPI-12-CB1 carrier is designed to accept both the PRM/VTM combination of evaluation boards, as well as the standalone BCM evaluation board.

The differential-mode EMI is typically larger in magnitude than common-mode, since common-mode is created by the physical imbalances in the differential loop path. Reducing differential EMI will cause a reduction in common-mode EMI.

EMI Filtering

The basic premise of filtering EMI is to insert a high impedance, at the EMI's base frequency, in both the differential- and common-mode paths as it returns to the power source.

Passive filters use common-mode chokes and "Y" capacitors to filter out common-mode EMI. These chokes are designed to present a high impedance at the EMI frequency in series with the return path, and a low-impedance path to the earth signal via the "Y" caps. This network will force the EMI signals to re-circulate within a confined area and not to propagate to the outside world. Often two common-mode networks are required to filter EMI within the frequency span required to pass the EN55022 Class B limits.

The other component of the passive filter is the differential LC network. Again, the inductor is chosen such that it will present a high impedance in the differential EMI loop at the EMI's base frequency. The differential capacitor will then shunt the EMI back to its source. The QPI-12 was specifically designed to work with higher switching frequency converters like Vicor VI Chip® products; PRM, VTM and BCM modules; as well as their newer VI Brick® product series.

EMI Management

The more effectively EMI is managed at the source, namely the power converter, the less EMI attenuation the filter will have to do. The addition of “Y” capacitors to the input and output power nodes of the converter will help to limit the amount of EMI that tries to propagate to the input source.

There are two basic topologies for the connection of the recirculating “Y” capacitors. In Figure 1 the open-frame topology is shown in the Vicor EMI test setup. The “Y” capacitors (CY1 to CY4) recirculate the EMI signals between the positive input and output, and the negative input and output of the power conversion stage.

Figure 2 shows the baseplate topology of recirculating “Y” caps. Here, CY5 to CY10 are connected to each power node of the PRM™ and VTM™, and then are commoned together on a copper shield plane created under the converter. The addition of the copper shield plane helps in the containment of the radiated EMI, converting it back to conducted EMI and shunting it back to its source.

Both of these topologies work well with the PRM/VTM combination shown above in attenuating noise levels well below Class B EMI limits.

Attenuation Test Set Ups

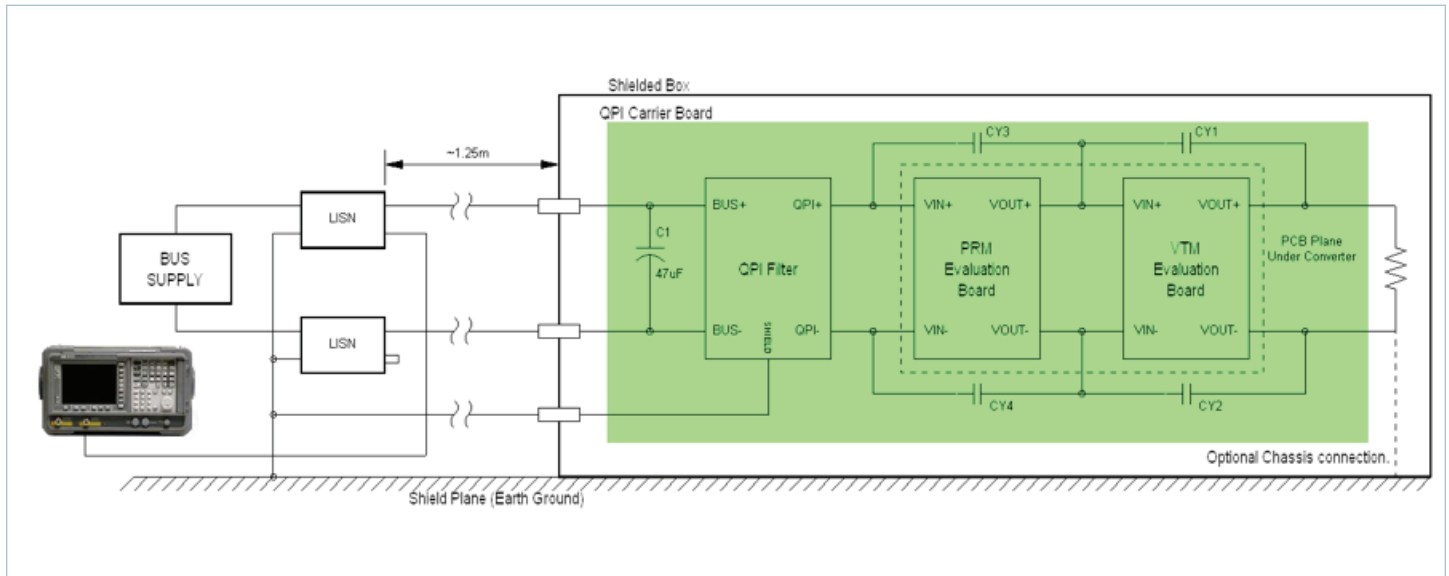

Figure 1 — Open-frame EMI test setup using the QPI-12-CB1 carrier board with VI Chip® evaluation boards

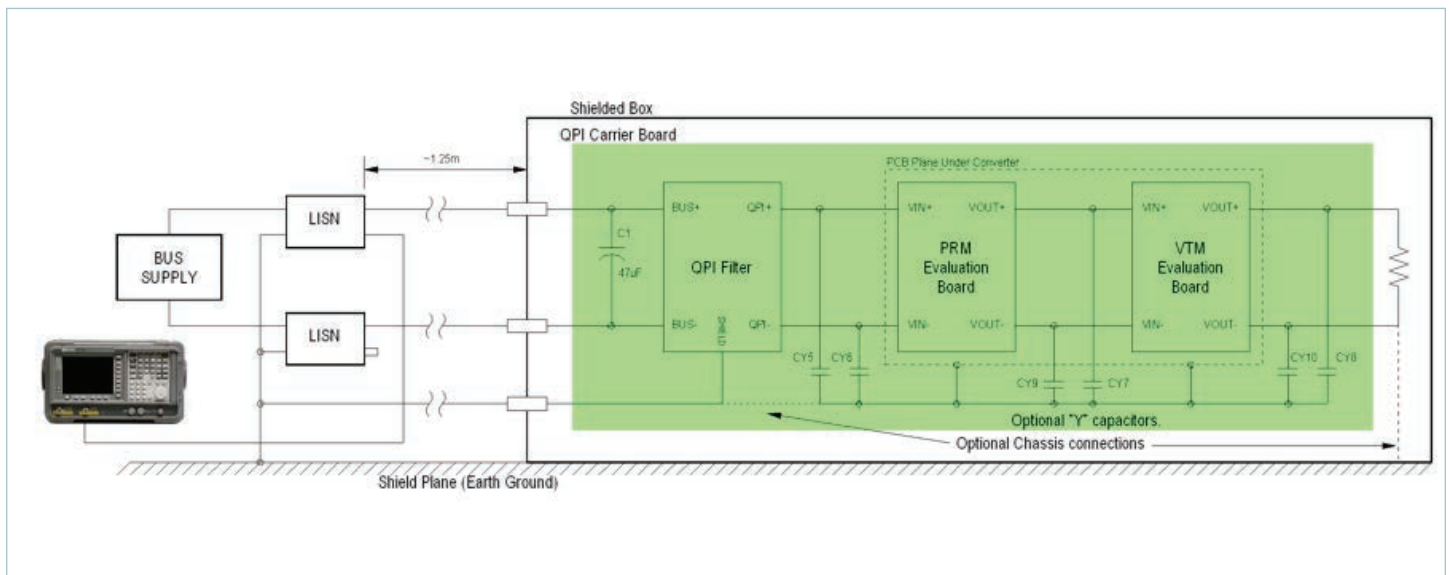

Figure 2 — Baseplate EMI test setup using the QPI-12-CB1 carrier board with VI Chip evaluation boards

Attenuation Plots

QPI-12 with PRM™ P048F048T24AL-CB and various VTMTM modules, connected in baseplate configuration, as shown in Figure 1.

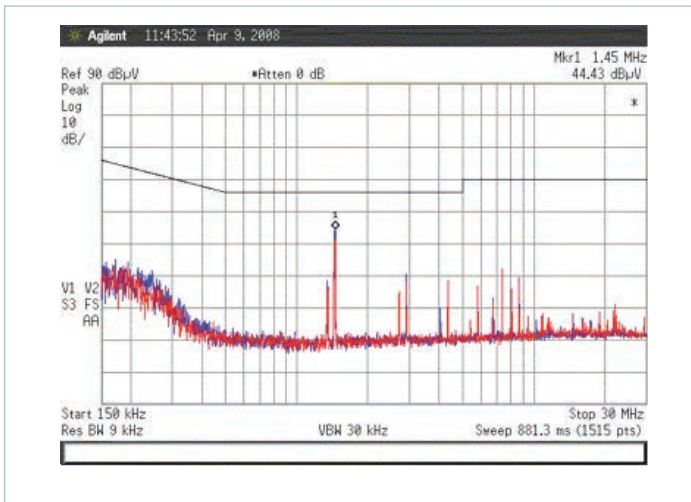

Figure 3 — VTM V048F030T070-CB with 160W load

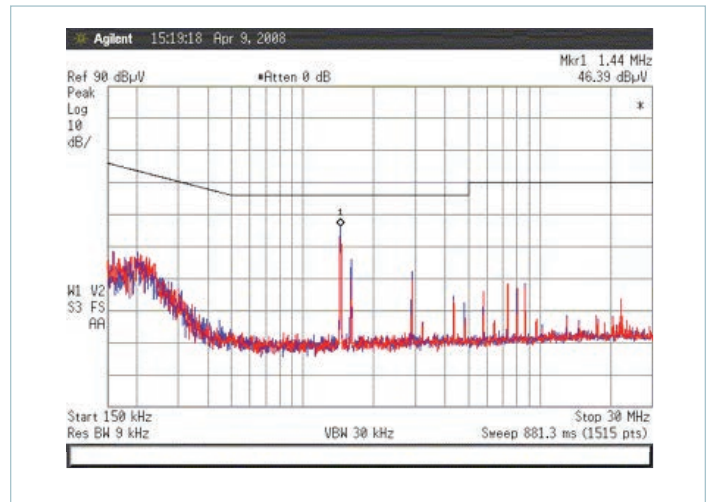

Figure 4 — VTM V048F120T025-CB with 180W load

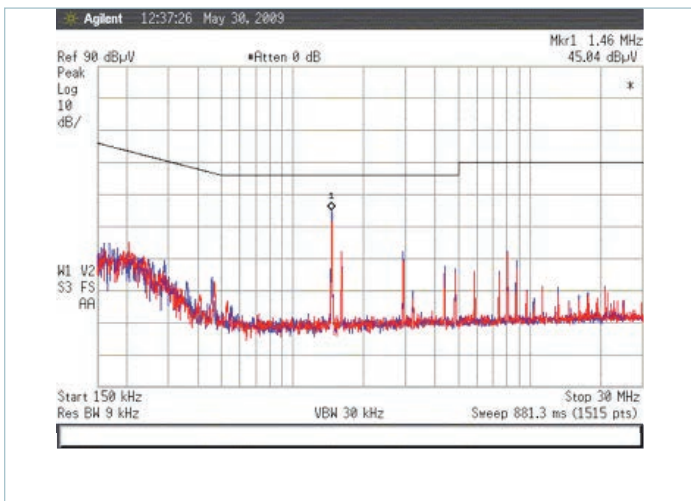

Figure 5 — VTM V048F240T012-CB with 172W output load

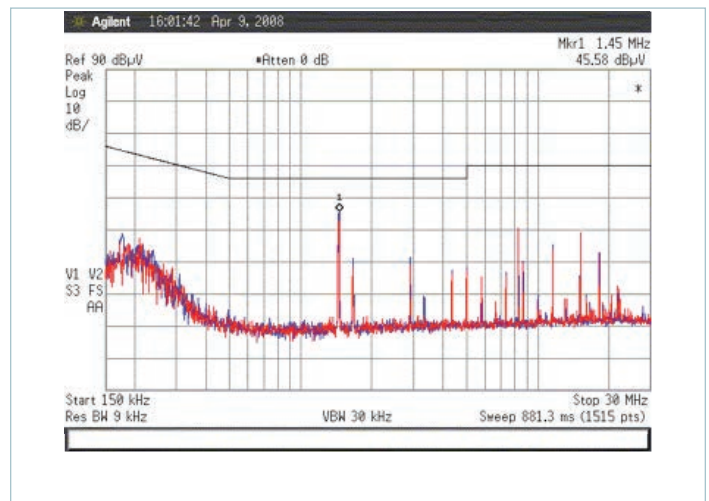

Figure 6 — VTM V048F480T006-CB with 153W load

Attenuation Plots (Cont.)

QPI-12 with various BCM® modules, connected in open-frame configuration, as shown in Figure 12.

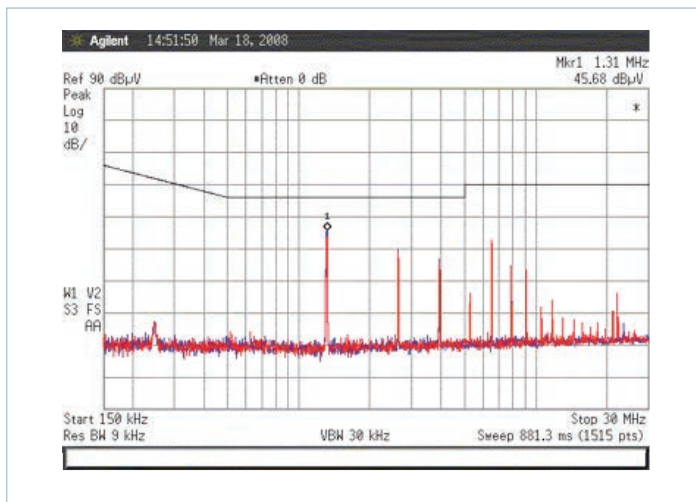

Figure 7 — BCM B048F030T21-EB with 160W load

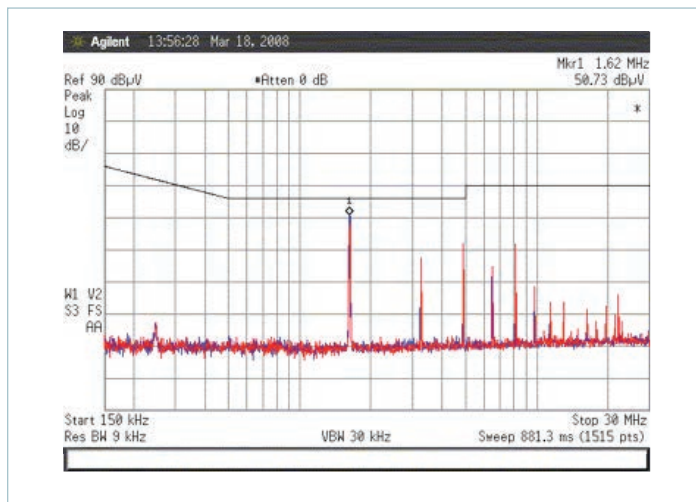

Figure 8 — BCM B048F120T30-EB with 180W load

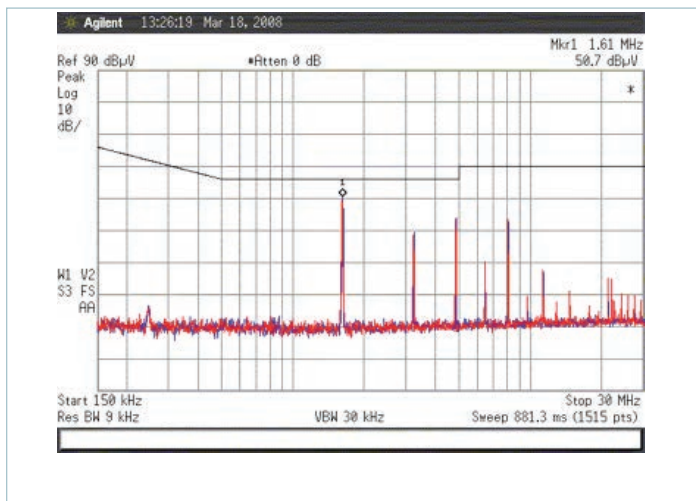

Figure 9 — BCM B048F240T30-EB with 172W load

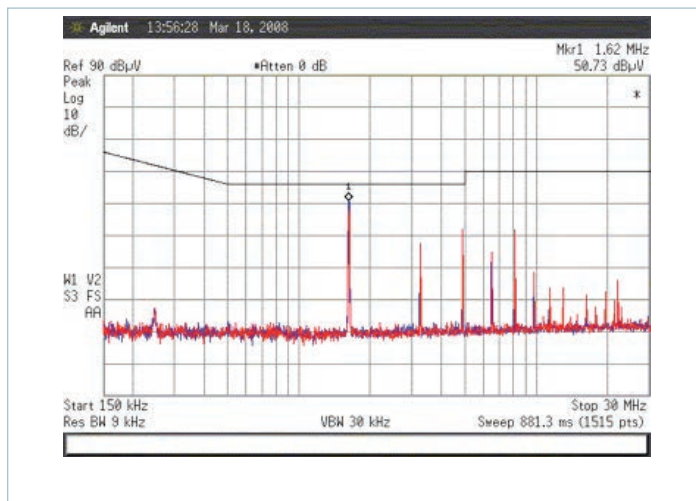

Figure 10 — BCM B048F480T30-EB with 152W load

Current De-Rating

Mounted to QPI-12-CB1 Evaluation Board.

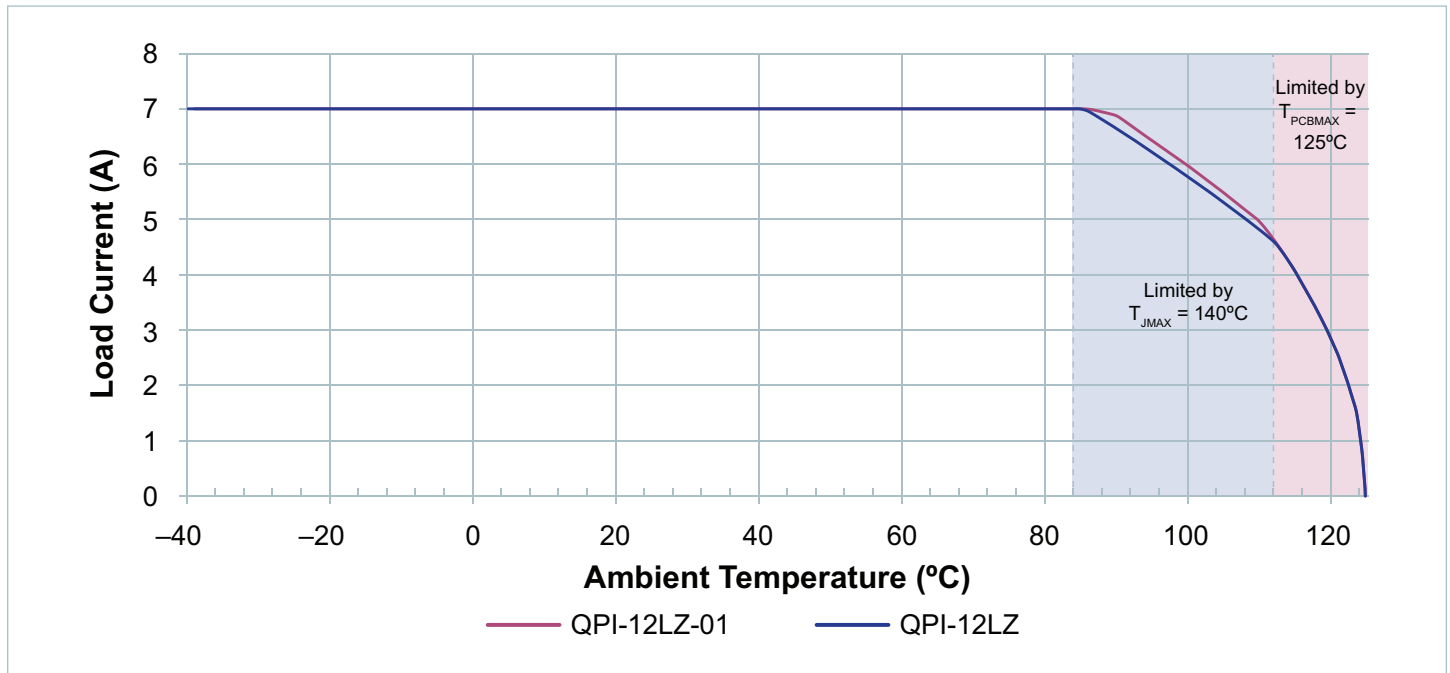

Figure 11 — Current de-rating over ambient temperature range

Converter Output Grounding

Recommended configurations.

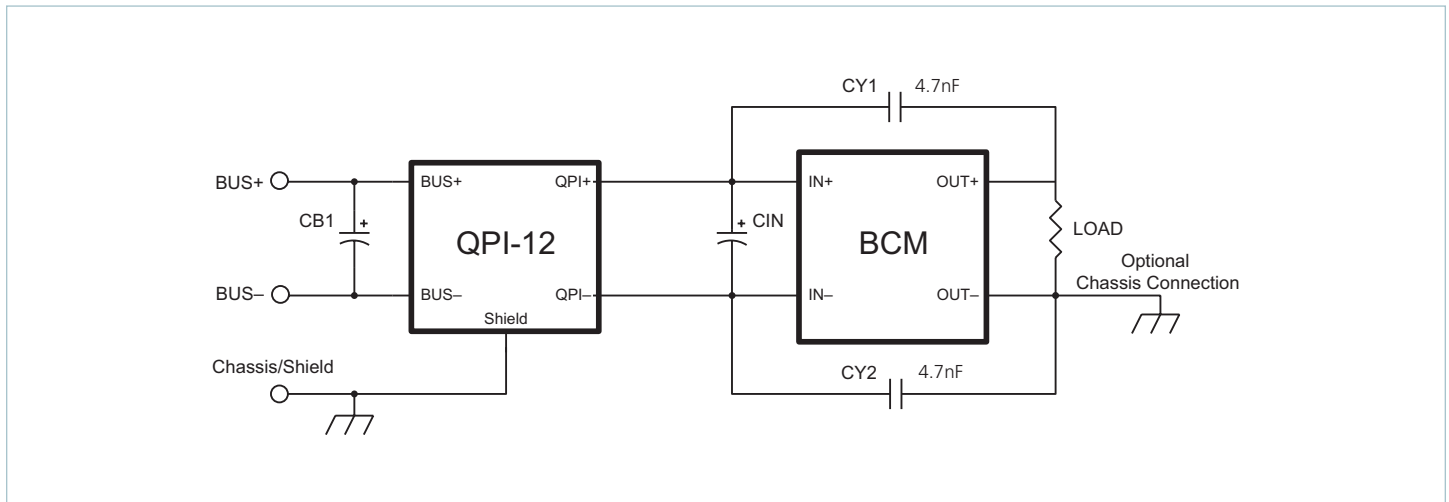

Figure 12 — BCM® converter in open-frame configuration with the output connected to chassis/earth

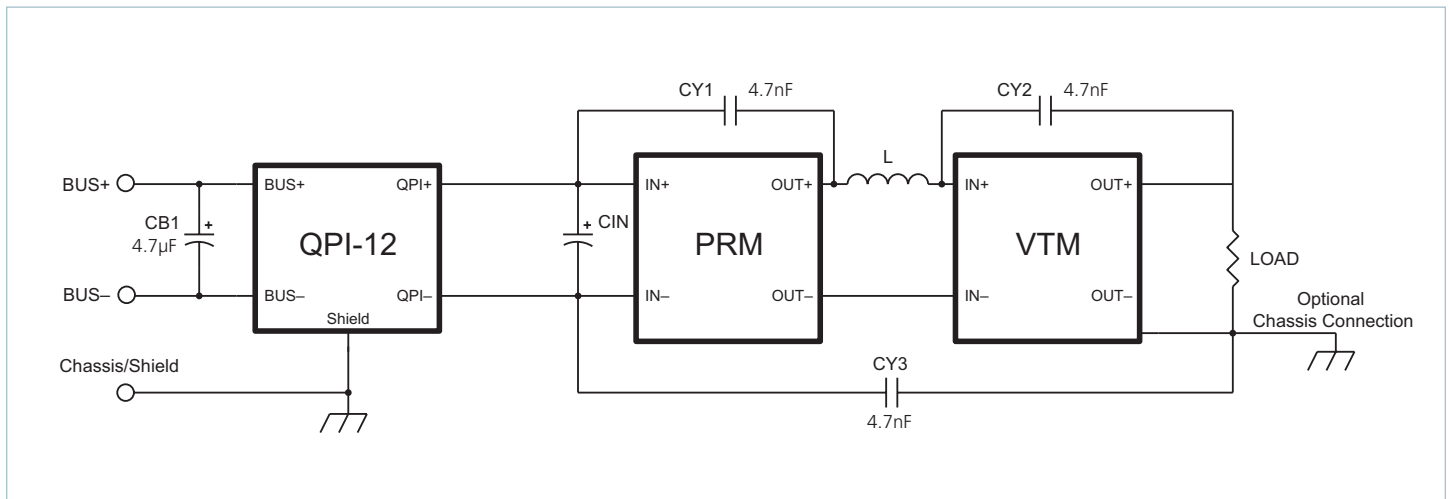

Figure 13 — PRM™/VTM™ in open-frame configuration with the output connected to the chassis/earth

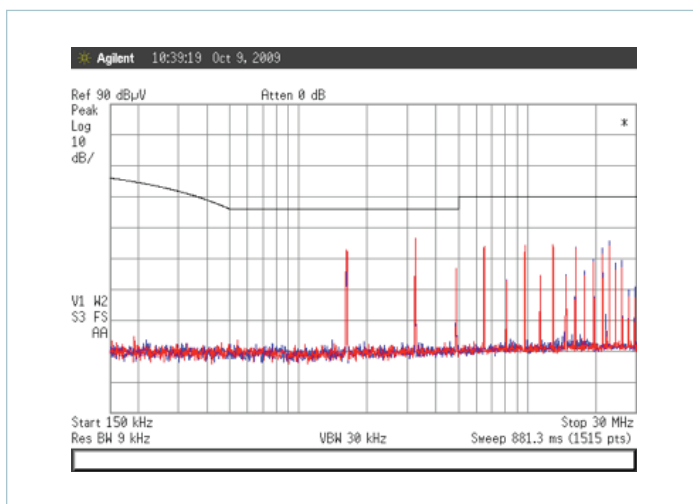

Figure 14 — Total noise plot of BCM with its output return connected to chassis, as shown in Figure 12, 125W load.

When using the QPI-12 with a Vicor PRM™/VTM™ or BCM® in a power system that requires the converter’s output to be connected to chassis/earth, Vicor recommends using the open-frame configuration of “Y” capacitors, shown in Figure 12, to re-circulate EMI currents. A baseplate configuration could also be used with a slight decrease in EMI attenuation, but with peaks well below class B limits.

The plot in Figure 14 is of a B048F120T30, with a 125W load, with the output ground connected to the chassis. When using the open-frame configuration of “Y” caps, the EMI shield plane is not used by the “Y” capacitors for recirculating EMI currents.

This configuration would also be recommended for a QPI-12 with a PRM/VTM pair, configured as shown in the PRM/VTM typical application schematic on page 1.

The QPI-12 is not designed to be used in parallel with another QPI-12 to achieve a higher current rating, but it can be used multiple times within a system design.

QPI Insertion Loss Measurements and Test Circuits

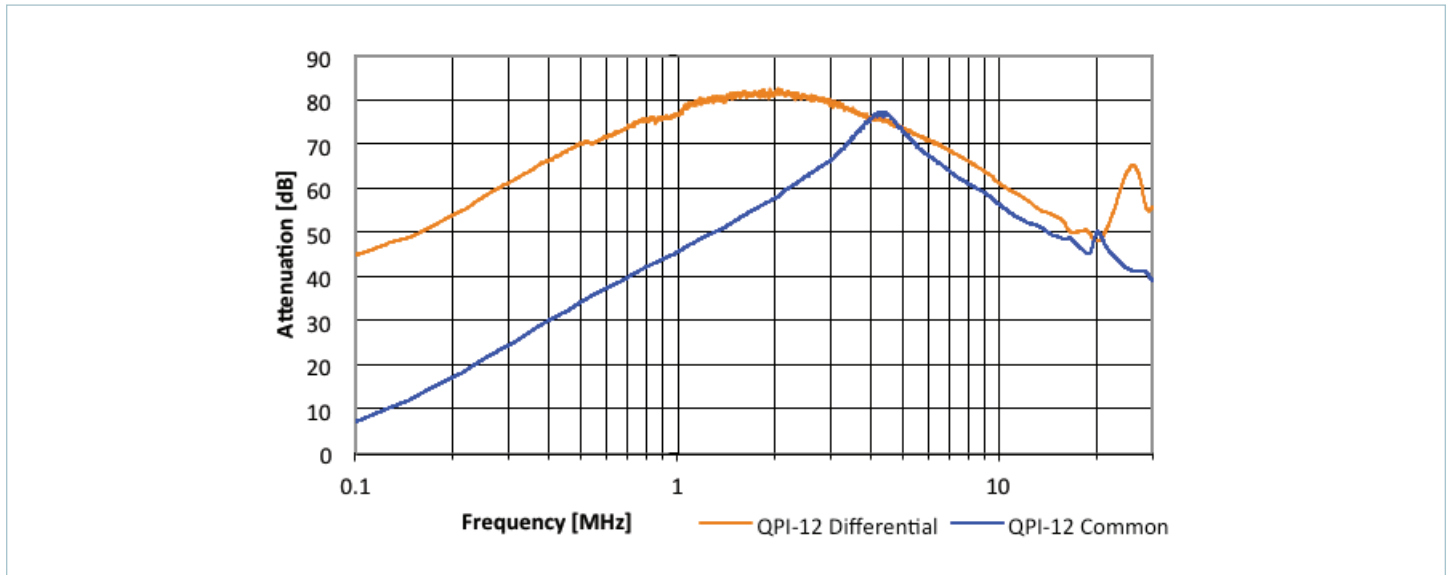

Figure 15 — Attenuation curves into a 50Ω line impedance, bias from a 48V bus

Insertion loss equation:

$$Insertion\ Loss = 20\log\left(\frac{I_{INA}}{I_{INB}}\right)$$

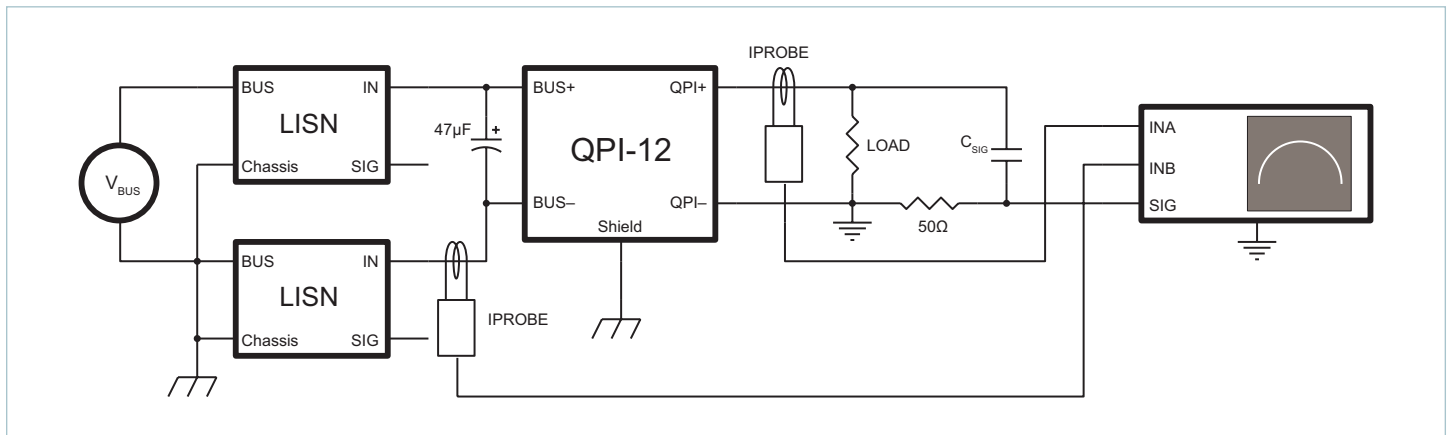

Figure 16 — Test set up to measure differential-mode EMI currents in Figure 15

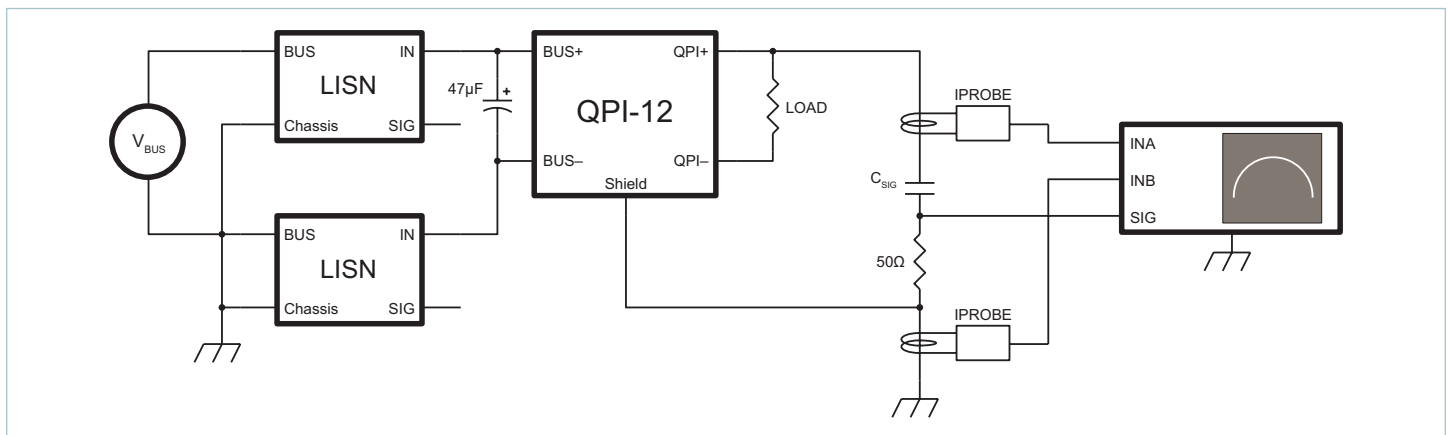

Figure 17 — Test set up to measure common-mode EMI currents in Figure 15

Package Outline Drawings

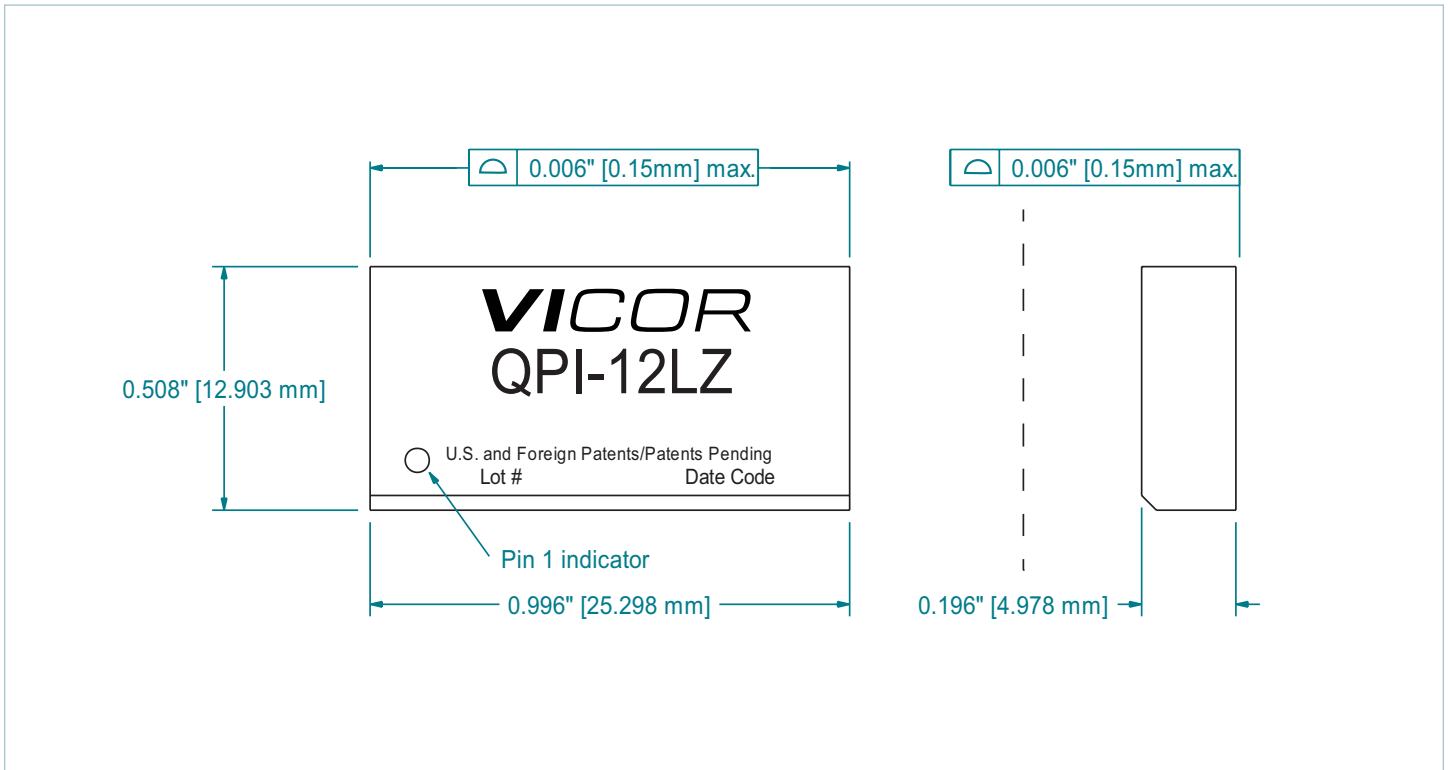

Figure 18 — Lidded package dimensions, tolerance of ± 0.004 in

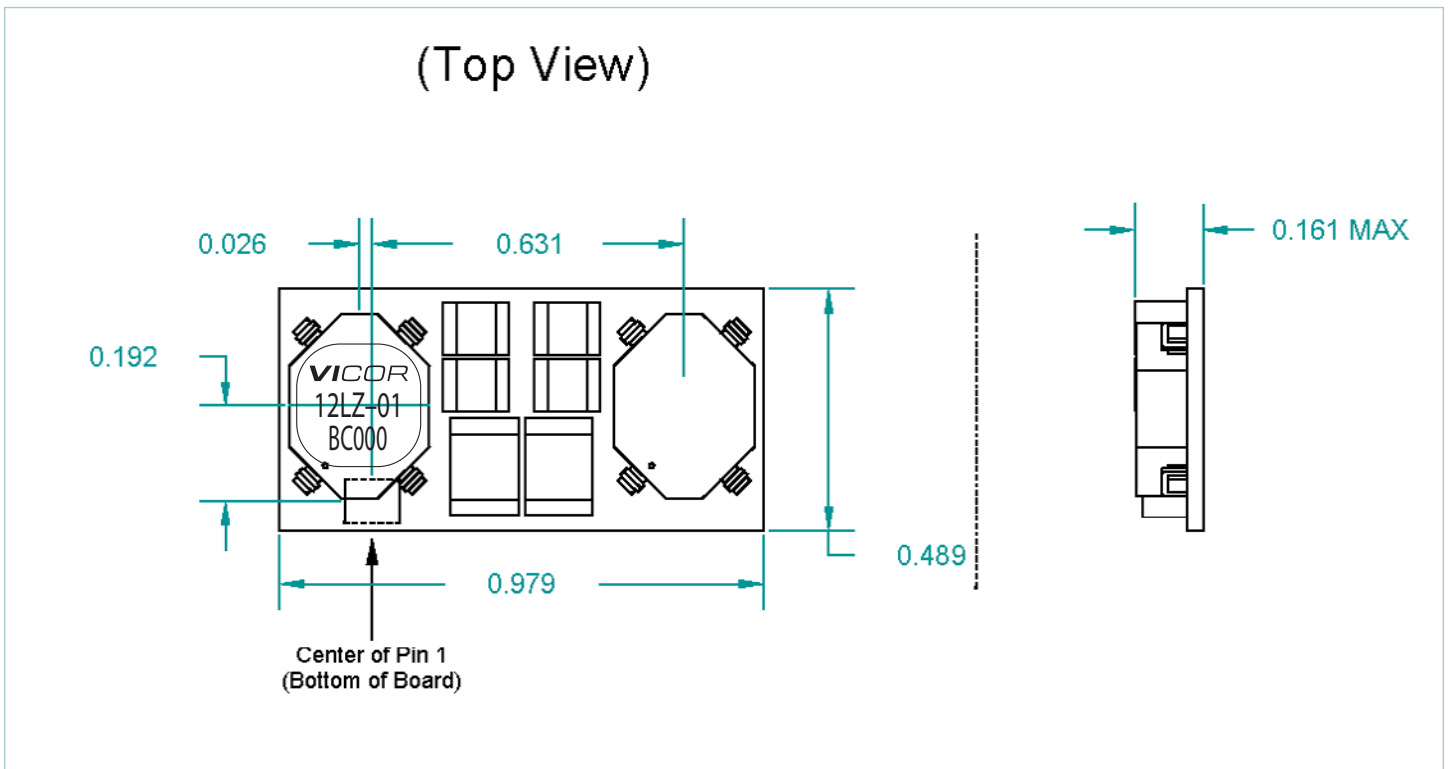

Figure 19 — Open-frame package dimensions, tolerance of ± 0.004 in; pick-and-place from label center

Pad and Stencil Definitions

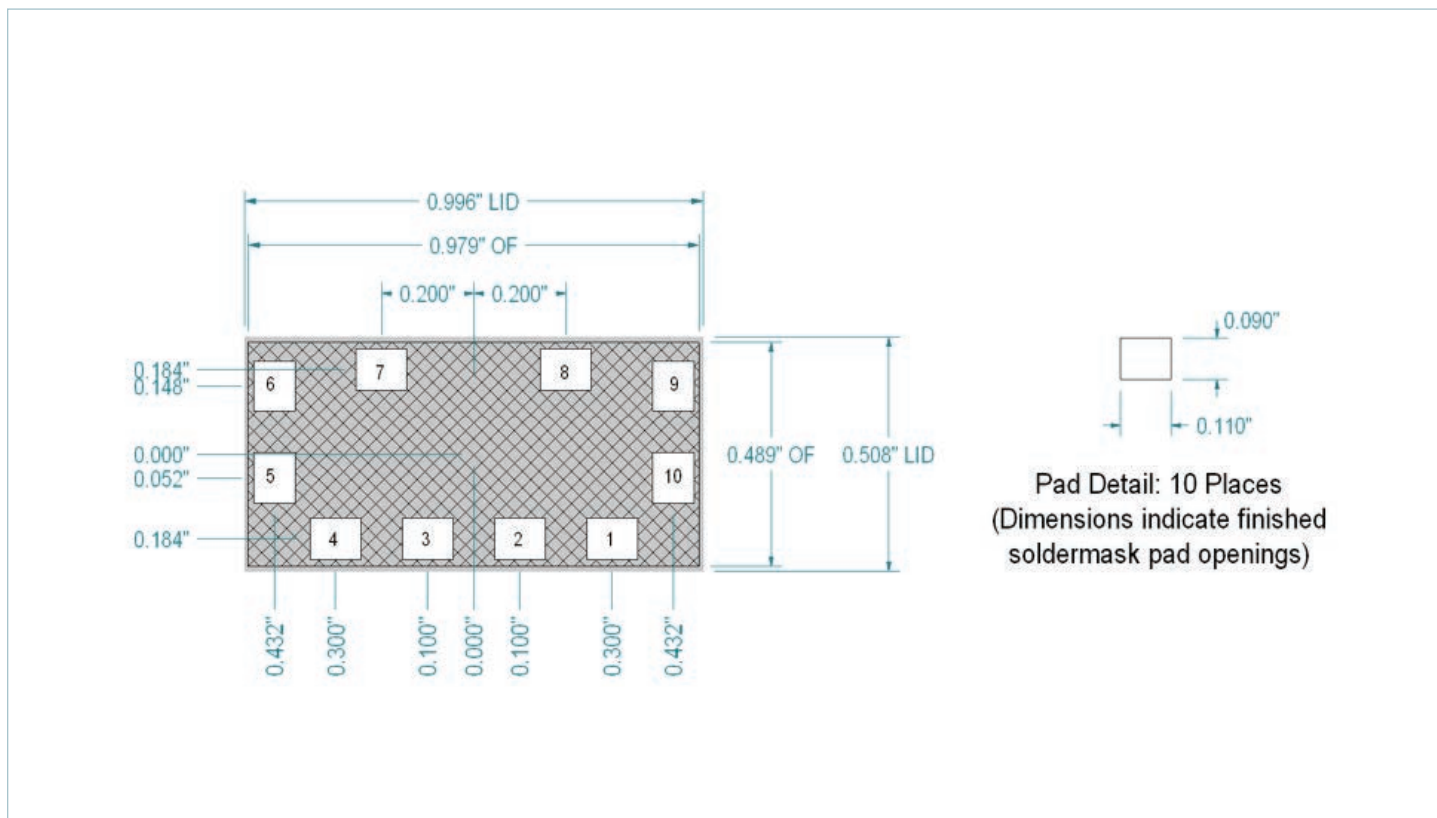

Figure 20 — Bottom view of open-frame (OF) and lidded (LID) products (all dimensions are in inches)

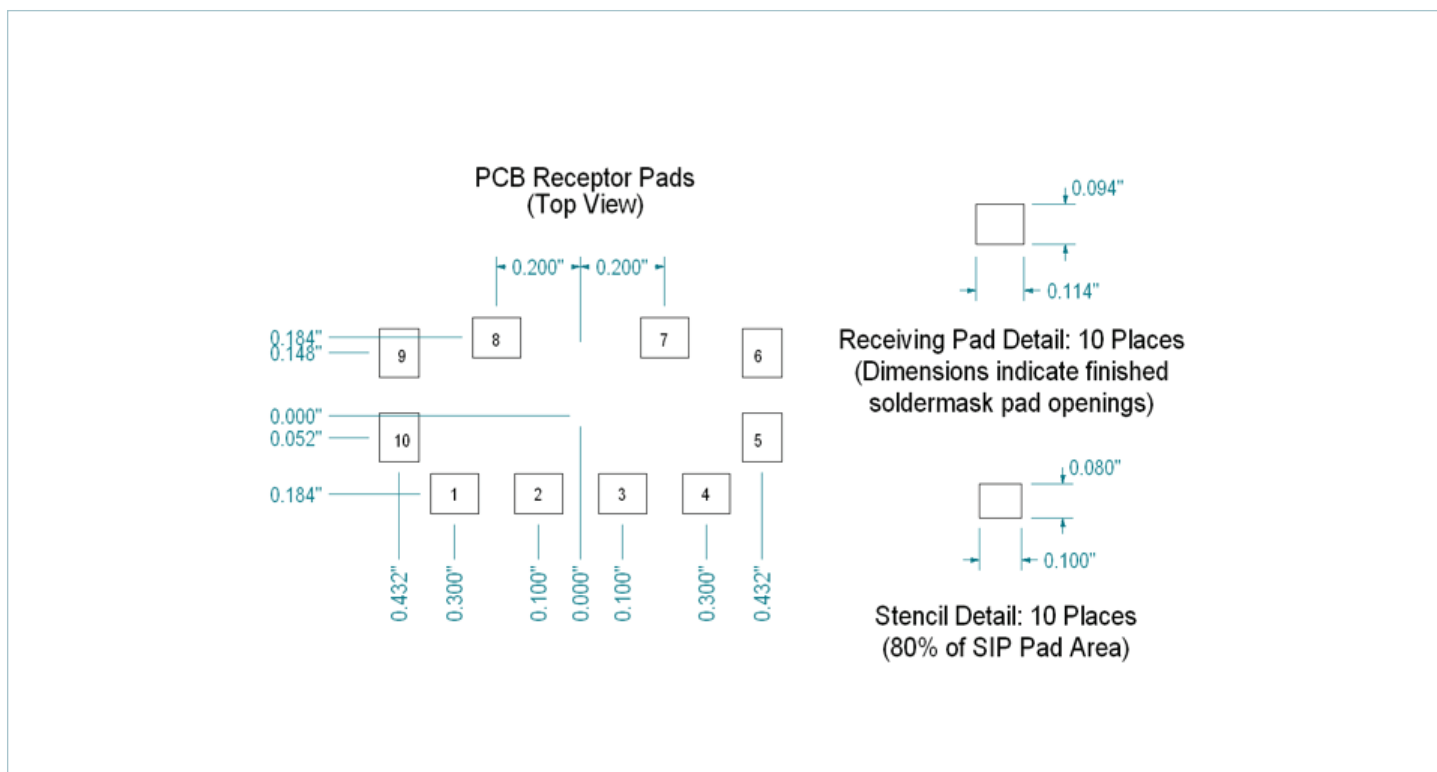

Figure 21 — Recommended receptor and stencil patterns (all dimensions are in inches)

Note: Stencil definition is based on a 6mil stencil thickness, 80% of LGA pad area coverage.
 LGA Package dimensions are for both the open-frame and lidded versions of the QPI-12.

PCB Layout Recommendations

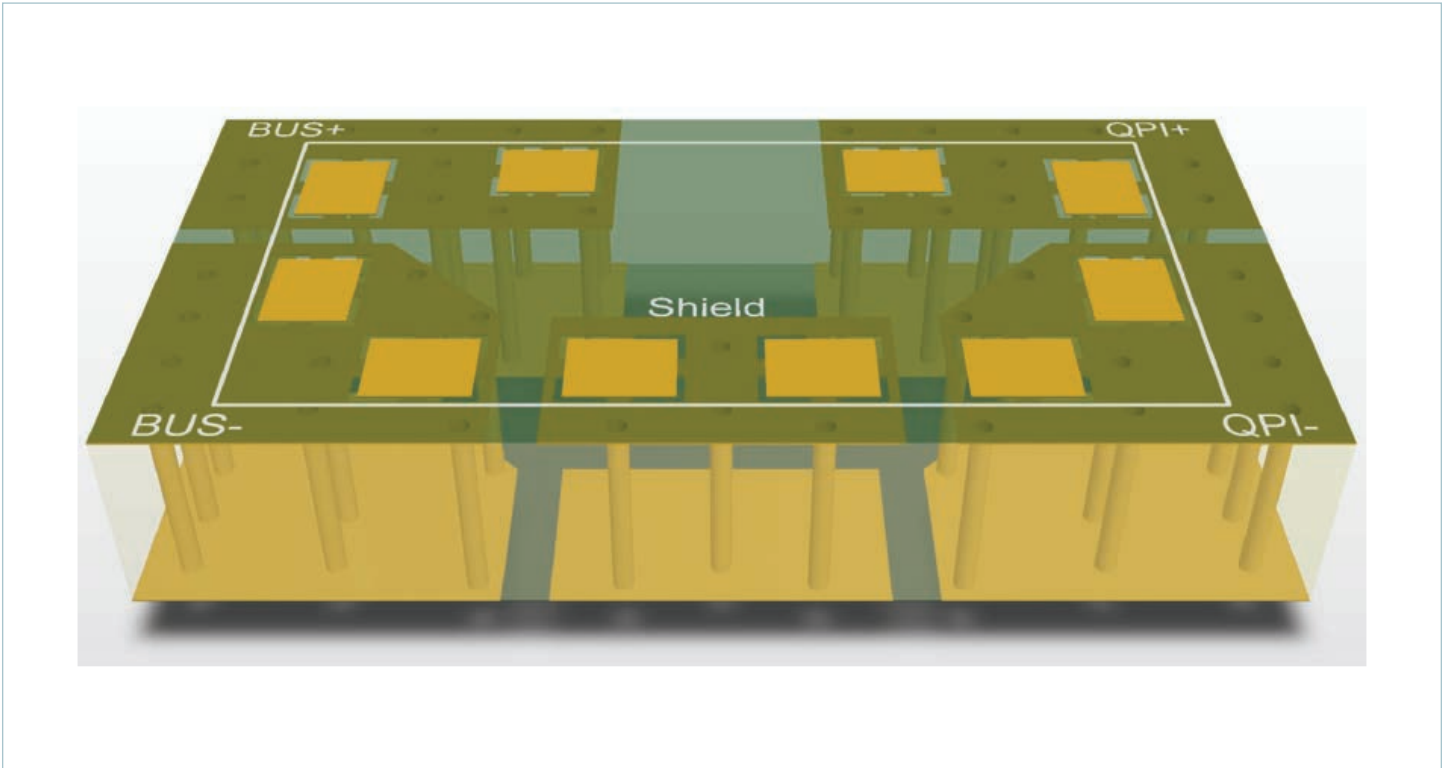

Figure 22 — 3D view of paralleling planes underneath the QPI-12

PCB Layout

The filtering performance of the QPI-12 is sensitive to capacitive coupling between its input and output pins. Parasitic plane capacitance must be kept below one pico-Farad between inputs and outputs using the layout shown above and the recommendations described below to achieve maximum conducted EMI performance.

To avoid capacitive coupling between input and output pins, there should not be any planes or large traces that run under both input and output pins, such as a ground plane or power plane. For example, if there are two signal planes or large traces where one trace runs under the input pins, and the other under the output pins, and both planes overlap in another area, they will cause capacitive coupling between input and output pins. Also, planes that run under both input and outputs pins, but do not cross, can cause capacitive coupling if they are capacitively bypassed together. Figure 22 shows the recommended PCB layout on a two-layer board. Here, the top layer planes are duplicated on the bottom layer so that there can be no overlapping of input and output planes. This method can be used for boards of greater layer count.

Post-Solder Cleaning

LZ version SiPs are not hermetically sealed and must not be exposed to liquid, including but not limited to cleaning solvents, aqueous washing solutions or pressurized sprays. When soldering, it is recommended that no-clean flux solder be used, as this will ensure that potentially corrosive mobile ions will not remain on, around or under the module following the soldering process. For applications where the end product must be cleaned in a liquid solvent, Vicor recommends using the QPI-12LZ-01, open-frame version of the EMI filter.

QPI-12 Mechanical Data

Datum	Units	QPI-12LZ	QPI-12LZ-01	Notes
FITS	Failure/Billion Hrs	16	16	FITS based on the BellCore Standard TR-332
MTBF	Million Hrs	62.5	62.5	MTBFs based on the BellCore Standard TR-332
Weight	grams	2.4	2.075	
MSL		3	3	
Peak Reflow Temperature	°C/20 seconds	245	245	IPC/JEDEC J-STD-020D

Vicor's comprehensive line of power solutions includes high density AC-DC and DC-DC modules and accessory components, fully configurable AC-DC and DC-DC power supplies, and complete custom power systems.

Information furnished by Vicor is believed to be accurate and reliable. However, no responsibility is assumed by Vicor for its use. Vicor makes no representations or warranties with respect to the accuracy or completeness of the contents of this publication. Vicor reserves the right to make changes to any products, specifications, and product descriptions at any time without notice. Information published by Vicor has been checked and is believed to be accurate at the time it was printed; however, Vicor assumes no responsibility for inaccuracies. Testing and other quality controls are used to the extent Vicor deems necessary to support Vicor's product warranty. Except where mandated by government requirements, testing of all parameters of each product is not necessarily performed.

Specifications are subject to change without notice.

Visit <http://www.vicorpower.com/dc-dc-filters/qpi> for the latest product information.

Vicor's Standard Terms and Conditions and Product Warranty

All sales are subject to Vicor's Standard Terms and Conditions of Sale, and Product Warranty which are available on Vicor's webpage (<http://www.vicorpower.com/termsconditionswarranty>) or upon request.

Life Support Policy

VICOR'S PRODUCTS ARE NOT AUTHORIZED FOR USE AS CRITICAL COMPONENTS IN LIFE SUPPORT DEVICES OR SYSTEMS WITHOUT THE EXPRESS PRIOR WRITTEN APPROVAL OF THE CHIEF EXECUTIVE OFFICER AND GENERAL COUNSEL OF VICOR CORPORATION. As used herein, life support devices or systems are devices which (a) are intended for surgical implant into the body, or (b) support or sustain life and whose failure to perform when properly used in accordance with instructions for use provided in the labeling can be reasonably expected to result in a significant injury to the user. A critical component is any component in a life support device or system whose failure to perform can be reasonably expected to cause the failure of the life support device or system or to affect its safety or effectiveness. Per Vicor Terms and Conditions of Sale, the user of Vicor products and components in life support applications assumes all risks of such use and indemnifies Vicor against all liability and damages.

Intellectual Property Notice

Vicor and its subsidiaries own Intellectual Property (including issued U.S. and Foreign Patents and pending patent applications) relating to the products described in this data sheet. No license, whether express, implied, or arising by estoppel or otherwise, to any intellectual property rights is granted by this document. Interested parties should contact Vicor's Intellectual Property Department.

The products described on this data sheet are protected by U.S. Patents. Please see www.vicorpower.com/patents for the latest patent information.

Contact Us: <http://www.vicorpower.com/contact-us>

Vicor Corporation
25 Frontage Road
Andover, MA, USA 01810
Tel: 800-735-6200
Fax: 978-475-6715
www.vicorpower.com

email

Customer Service: custserv@vicorpower.com
Technical Support: apps@vicorpower.com