

REV.	ECN NO.	DATE	SIGN	DESCRIPTION
A	Initial Release	2015/10/10	Mila	Change Rev.01 To Rev.A

ALTW
CONFIDENTIAL
 2015-10-10
 R&D DEPT.

360° Adjustable Key Code Direction

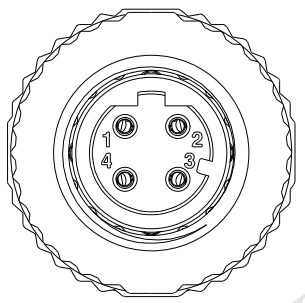
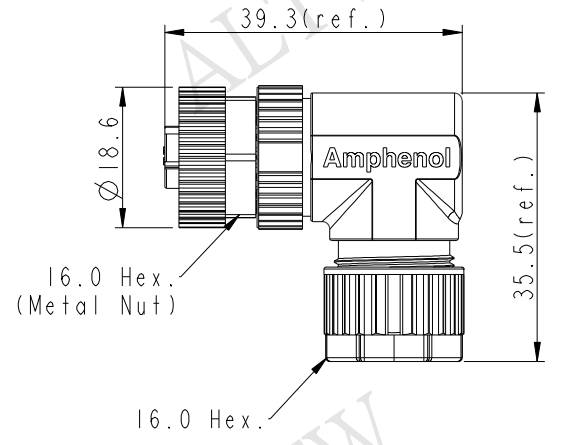
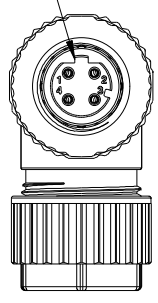
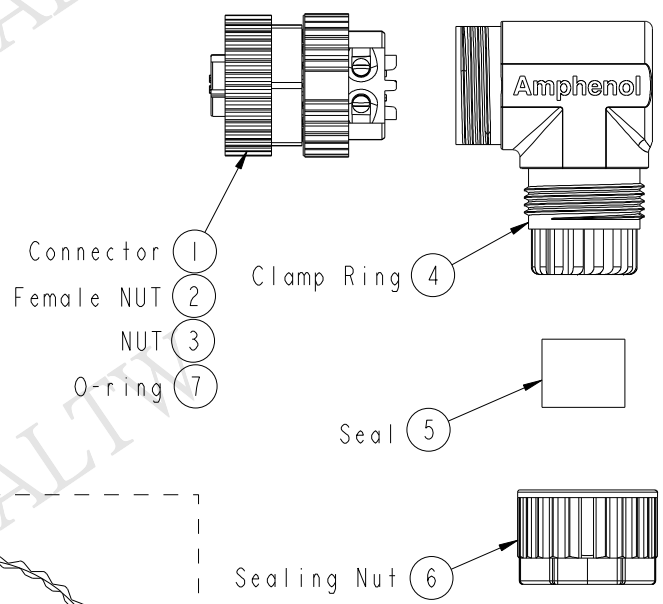

Pin Assignments
 Front View

ALTW
 DCC. DEPT.
 CONFIDENTIAL
 2015.10.28
 ISSUED

UNIT:mm		
TOLERANCE		
±0.5mm		

TITLE M12 D-Code 90° Unshielded Assy 4Pin F Conn. F Pin			
SCALE 1:1	SIZE A4	SHEET 1 OF 2	
REV. A	WC-REV. A.2	QC: Inspection item	

Amphenol LTW
 安費諾亮泰企業股份有限公司

ITEM NO. M12D-04BFFB-SR7001	DRAWN BY Mila	DATE 2015-10-10
DWG NO. M12D-04BFFB-SR7001	CHECKED BY Cary	DATE 2015-10-10
CUSTOMER ALTW	APPROVED BY Jerry	DATE 2015-10-10

THIS DOCUMENT IS SUBJECT TO CHANGE WITHOUT NOTICE. IT IS CONFIDENTIAL AND A PROPERTY OF Amphenol LTW. DISCLOSURE TO THIRD PARTY HAS TO BE AUTHORIZED BY Amphenol LTW.

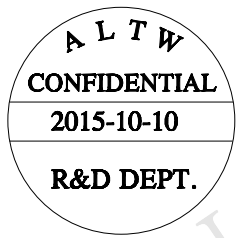
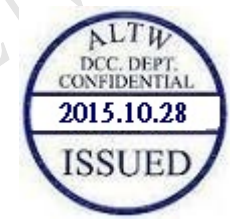
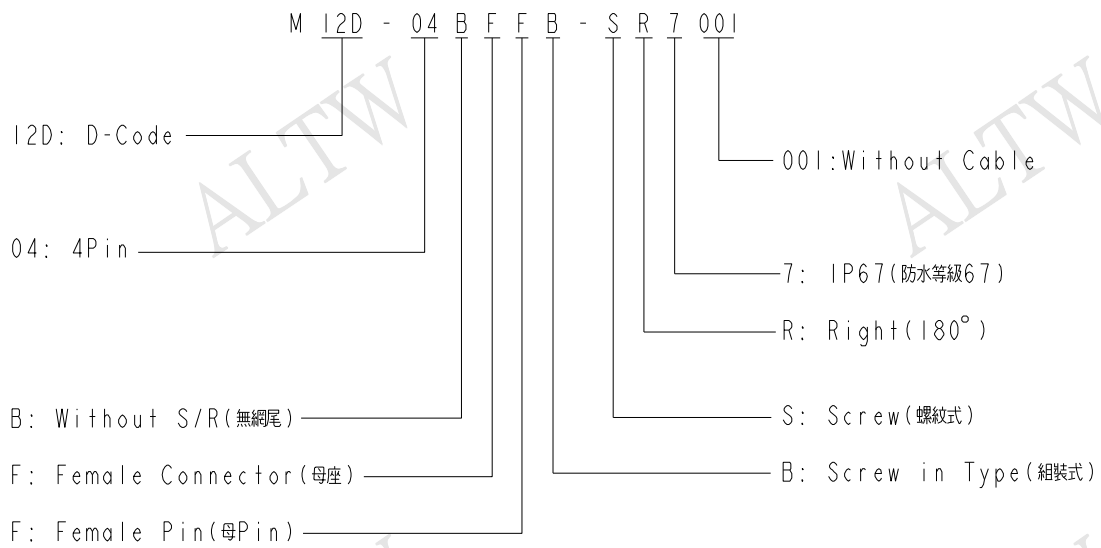

- Note:
- * \varnothing Important Dimension To Check.
 - * Waterproof Rate: IP67(Mated)
 - * Housing: Nylon,Black
 - * Female Pin: Copper Alloy, Gold Plated
 - * Female Nut: Zinc Alloy, Nickel Plated
 - * Nut: PBT+PC, Black
 - * O-Ring: Silicon,Grey
 - * Clamp Ring: Nylon,Black
 - * Sealing Nut: PBT+PC,Black
 - * Seal: Silicon,Grey
 - * Seal For Cable OD: $\varnothing 4.0\text{mm} \sim \varnothing 7.0\text{mm}$
 - * Screws for Wire connection recommended
tightening torque: 0.61~0.84 kgf.cm / 0.059~0.082 N.m
 - * Applicable Wire gauge (Stranded wire cross section)
0.14mm² (26AWG) ~ 0.82mm² (18AWG)
 - * Mating Recommended tightening torque:
3~4 kgf.cm / 0.29~0.39 N.m
 - * Sealing-Nut Recommended tightening torque:
4~6 kgf.cm / 0.39~0.59 N.m
 - * Detailed applicable wire specifications may vary
depending on the actual wire construction.

UNIT:mm		
TOLERANCE		
±0.5mm		

TITLE M12 D-Code 90° Unshielded Assy 4Pin F Conn. F Pin			
SCALE 1:1	SIZE A4	SHEET 2 OF 2	
REV. A	WC-REV. A.2	\varnothing : Inspection item	

Amphenol LTW
安費諾亮泰企業股份有限公司

ITEM NO M12D-04BFFB-SR7001	DRAWN BY Mila	DATE 2015-10-10
DWG NO M12D-04BFFB-SR7001	CHECKED BY Cary	DATE 2015-10-10
CUSTOMER ALTW	APPROVED BY Jerry	DATE 2015-10-10