

Trench Gate Design Dual IGBTMOD™ 100 Amperes/600 Volts

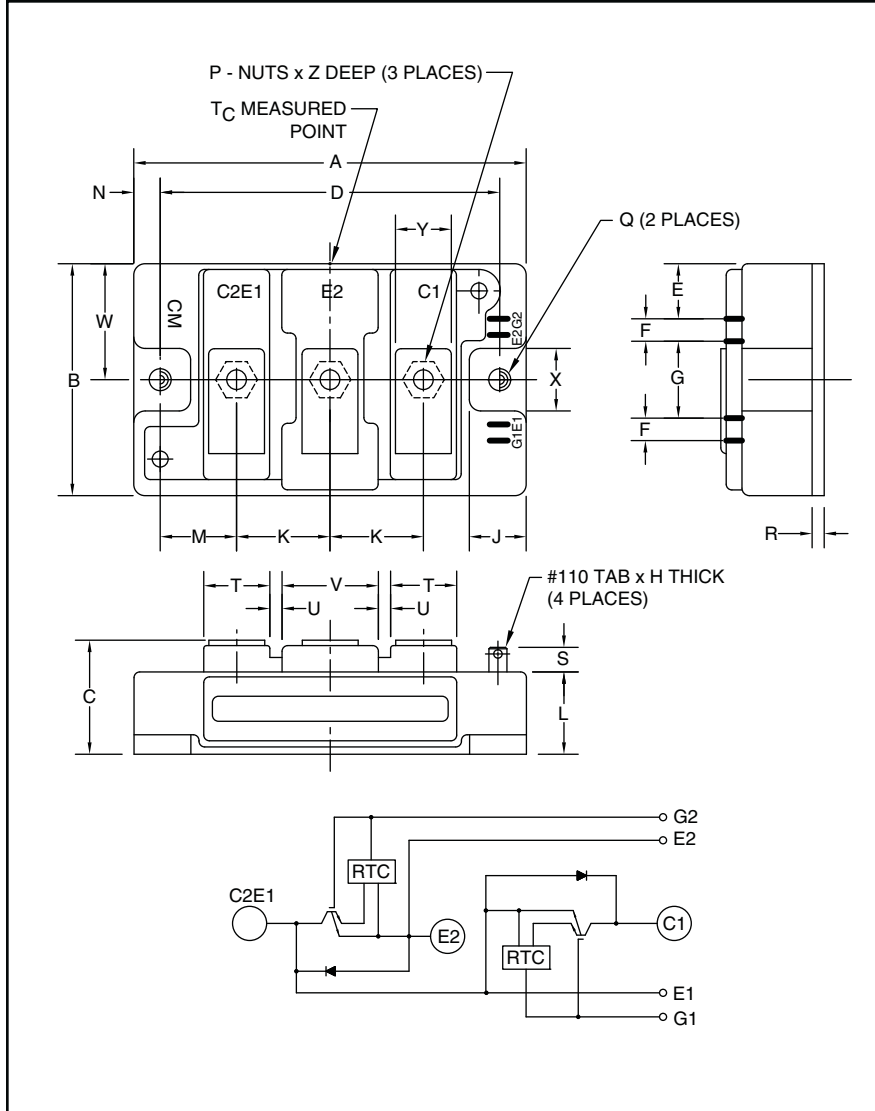

Outline Drawing and Circuit Diagram

| Dimensions | Inches | Millimeters |
|------------|------------------|----------------|
| A | 3.70 | 94.0 |
| B | 1.89 | 48.0 |
| C | 1.18 +0.04/-0.02 | 30.0 +1.0/-0.5 |
| D | 3.15±0.01 | 80.0±0.25 |
| E | 0.43 | 11.0 |
| F | 0.16 | 4.0 |
| G | 0.71 | 18.0 |
| H | 0.02 | 0.5 |
| J | 0.53 | 13.5 |
| K | 0.91 | 23.0 |
| L | 0.83 | 21.2 |
| M | 0.67 | 17.0 |

| Dimensions | Inches | Millimeters |
|------------|-----------|-------------|
| N | 0.28 | 7.0 |
| P | M5 | M5 |
| Q | 0.26 Dia. | 6.5 Dia. |
| R | 0.02 | 4.0 |
| S | 0.30 | 7.5 |
| T | 0.63 | 16.0 |
| U | 0.10 | 2.5 |
| V | 1.0 | 25.0 |
| W | 0.94 | 24.0 |
| X | 0.51 | 13.0 |
| Y | 0.47 | 12.0 |
| Z | 0.47 | 12.0 |



Description:

Powerex IGBTMOD™ Modules are designed for use in high frequency applications; 30 kHz for hard switching applications and 60 to 70 kHz for soft switching applications. Each module consists of two IGBT Transistors in a half-bridge configuration with each transistor having a reverse-connected super-fast recovery free-wheel diode. All components and interconnects are isolated from the heat sinking baseplate, offering simplified system assembly and thermal management.

Features:

- Low V_{CE(sat)}
- Low E_{SW(off)}
- Discrete Super-Fast Recovery Free-Wheel Diode
- Isolated Baseplate for Easy Heat Sinking

Applications:

- Power Supplies
- Induction Heating
- Welders

Ordering Information:

Example: Select the complete module number you desire from the table - i.e. CM100DUS-12F is a 600V (V_{CE(s)}), 100 Ampere Dual IGBTMOD™ Power Module.

| Type | Current Rating Amperes | V _{CE(s)} Volts (x 50) |
|------|---------------------------|------------------------------------|
| CM | 100 | 12 |



Powerex, Inc., 200 E. Hillis Street, Youngwood, Pennsylvania 15697-1800 (724) 925-7272

CM100DUS-12F
Trench Gate Design Dual IGBTMOD™
 100 Amperes/600 Volts

Absolute Maximum Ratings, $T_j = 25^\circ\text{C}$ unless otherwise specified

| Ratings | Symbol | CM100DUS-12F | Units |
|---|-----------|--------------|------------------|
| Junction Temperature | T_j | -40 to 150 | $^\circ\text{C}$ |
| Storage Temperature | T_{stg} | -40 to 125 | $^\circ\text{C}$ |
| Collector-Emitter Voltage (G-E SHORT) | V_{CES} | 600 | Volts |
| Gate-Emitter Voltage (C-E SHORT) | V_{GES} | ± 20 | Volts |
| Collector Current ($T_c = 25^\circ\text{C}$) | I_C | 100 | Amperes |
| Peak Collector Current | I_{CM} | 200* | Amperes |
| Emitter Current** ($T_c = 25^\circ\text{C}$) | I_E | 100 | Amperes |
| Peak Emitter Current** | I_{EM} | 200* | Amperes |
| Maximum Collector Dissipation ($T_c = 25^\circ\text{C}$, $T_j \leq 150^\circ\text{C}$) | P_c | 350 | Watts |
| Mounting Torque, M5 Main Terminal | – | 31 | in-lb |
| Mounting Torque, M6 Mounting | – | 40 | in-lb |
| Weight | – | 310 | Grams |
| Isolation Voltage (Main Terminal to Baseplate, AC 1 min.) | V_{iso} | 2500 | Volts |

* Pulse width and repetition rate should be such that the device junction temperature (T_j) does not exceed $T_{j(max)}$ rating.

**Represents characteristics of the anti-parallel, emitter-to-collector free-wheel diode (FWDi).

Static Electrical Characteristics, $T_j = 25^\circ\text{C}$ unless otherwise specified

| Characteristics | Symbol | Test Conditions | Min. | Typ. | Max. | Units |
|--------------------------------------|---------------|---|------|------|------|---------------|
| Collector-Cutoff Current | I_{CES} | $V_{CE} = V_{CES}$, $V_{GE} = 0V$ | – | – | 1 | mA |
| Gate Leakage Current | I_{GES} | $V_{GE} = V_{GES}$, $V_{CE} = 0V$ | – | – | 20 | μA |
| Gate-Emitter Threshold Voltage | $V_{GE(th)}$ | $I_C = 10\text{mA}$, $V_{CE} = 10V$ | 5 | 6 | 7 | Volts |
| Collector-Emitter Saturation Voltage | $V_{CE(sat)}$ | $I_C = 100A$, $V_{GE} = 15V$, $T_j = 25^\circ\text{C}$ | 1.7 | 2.0 | 2.7 | Volts |
| | | $I_C = 100A$, $V_{GE} = 15V$, $T_j = 125^\circ\text{C}$ | – | 1.95 | – | Volts |
| Total Gate Charge | Q_G | $V_{CC} = 300V$, $I_C = 100A$, $V_{GE} = 15V$ | – | 620 | – | nC |
| Emitter-Collector Voltage** | V_{EC} | $I_E = 100A$, $V_{GE} = 0V$ | – | – | 2.6 | Volts |

**Represents characteristics of the anti-parallel, emitter-to-collector free-wheel diode (FWDi).

Dynamic Electrical Characteristics, $T_j = 25^\circ\text{C}$ unless otherwise specified

| Characteristics | Symbol | Test Conditions | Min. | Typ. | Max. | Units |
|---------------------------------|---------------------|---|------|------|------|---------------|
| Input Capacitance | C_{ies} | | – | – | 27 | nf |
| Output Capacitance | C_{oes} | $V_{CE} = 10V$, $V_{GE} = 0V$ | – | – | 1.8 | nf |
| Reverse Transfer Capacitance | C_{res} | | – | – | 1 | nf |
| Resistive | Turn-on Delay Time | $V_{CC} = 300V$, $I_C = 100A$, $V_{GE1} = V_{GE2} = 15V$, | – | – | 100 | ns |
| | Rise Time | | | | | |
| Load | Turn-off Delay Time | $R_G = 6.3\Omega$, Inductive Load Switching Operation | – | – | 300 | ns |
| | Fall Time | | | | | |
| Diode Reverse Recovery Time** | t_{rr} | $I_E = 100A$ | – | – | 150 | ns |
| Diode Reverse Recovery Charge** | Q_{rr} | | – | 1.9 | – | μC |

**Represents characteristics of the anti-parallel, emitter-to-collector free-wheel diode (FWDi).



Powerex, Inc., 200 E. Hillis Street, Youngwood, Pennsylvania 15697-1800 (724) 925-7272

CM100DUS-12F
Trench Gate Design Dual IGBTMOD™
 100 Amperes/600 Volts

Thermal and Mechanical Characteristics, $T_j = 25^\circ\text{C}$ unless otherwise specified

| Characteristics | Symbol | Test Conditions | Min. | Typ. | Max. | Units |
|--------------------------------------|----------------|--|------|--------|------|--------------------|
| Thermal Resistance, Junction to Case | $R_{th(j-c)Q}$ | Per IGBT 1/2 Module, T_c Reference Point per Outline Drawing | – | | 0.35 | $^\circ\text{C/W}$ |
| Thermal Resistance, Junction to Case | $R_{th(j-c)D}$ | Per FWDi 1/2 Module, T_c Reference Point per Outline Drawing | – | – | 0.70 | $^\circ\text{C/W}$ |
| Thermal Resistance, Junction to Case | $R_{th(j-c)Q}$ | Per IGBT 1/2 Module, T_c Reference Point Under Chip | – | 0.23** | – | $^\circ\text{C/W}$ |
| Contact Thermal Resistance | $R_{th(c-f)}$ | Per Module, Thermal Grease Applied | – | 0.07 | – | $^\circ\text{C/W}$ |

** If you use this value, $R_{th(f-a)}$ should be measured just under the chips.

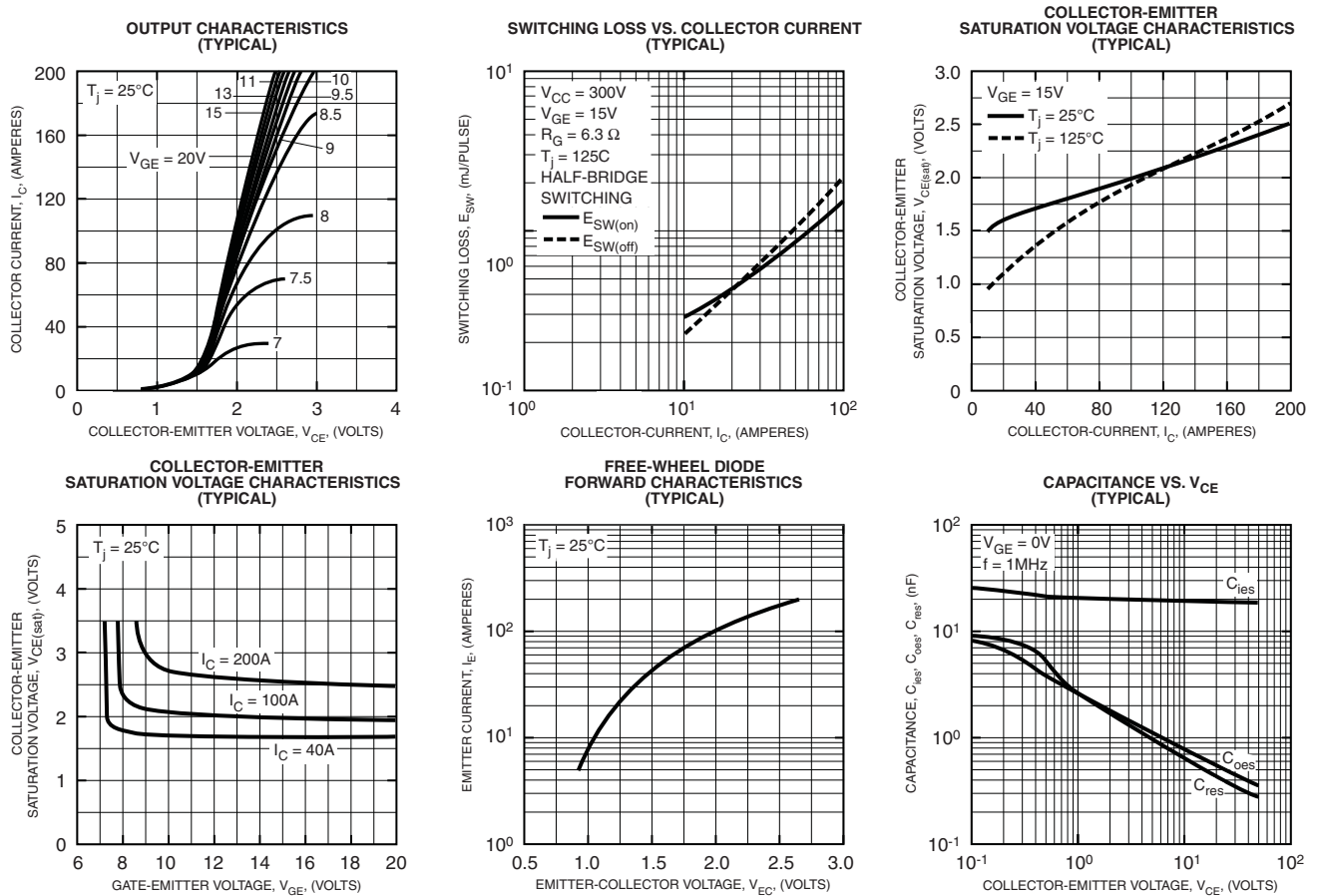



Powerex, Inc., 200 E. Hillis Street, Youngwood, Pennsylvania 15697-1800 (724) 925-7272

CM100DUS-12F
Trench Gate Design Dual IGBTMOD™
 100 Amperes/600 Volts

HALF-BRIDGE SWITCHING CHARACTERISTICS (TYPICAL)

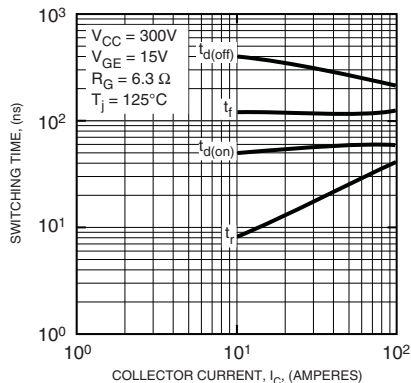

REVERSE RECOVERY CHARACTERISTICS (TYPICAL)

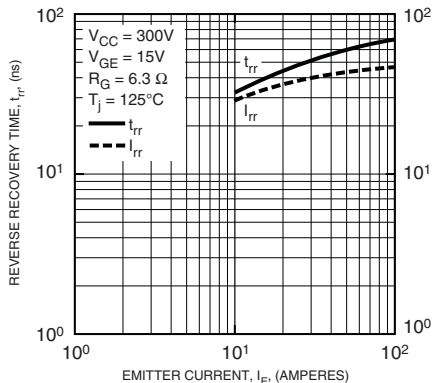

GATE CHARGE, V_{GE}

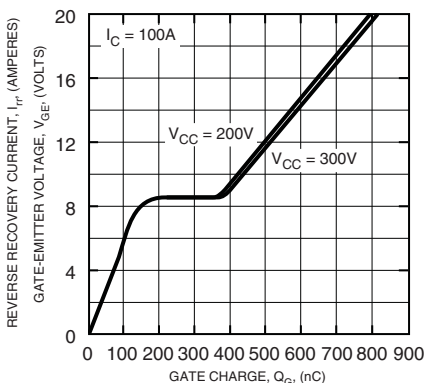

REVERSE RECOVERY SWITCHING LOSS VS. EMITTER CURRENT (TYPICAL)

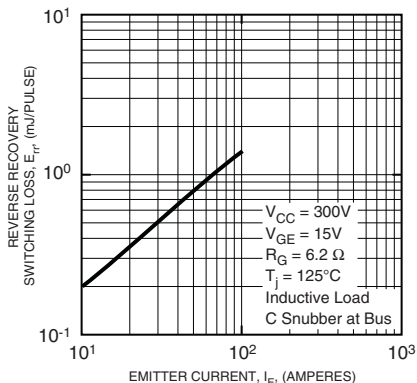

REVERSE RECOVERY SWITCHING LOSS VS. GATE RESISTANCE (TYPICAL)

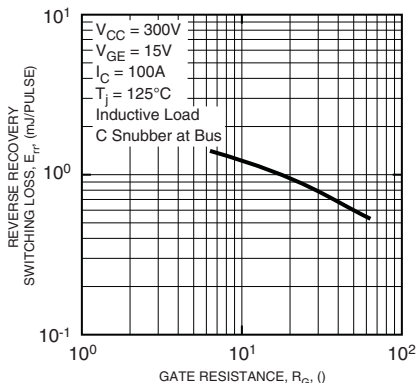

TRANSIENT THERMAL IMPEDANCE CHARACTERISTICS (IGBT)

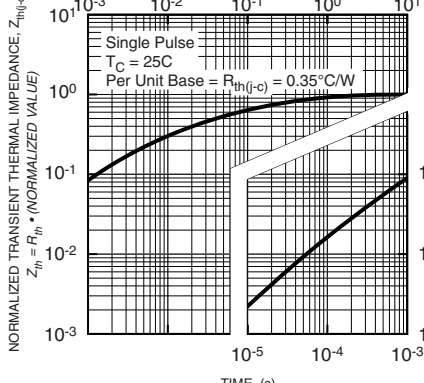

TRANSIENT THERMAL IMPEDANCE CHARACTERISTICS (FWDI)

