

THIS DOCUMENT IS SUBJECT TO CHANGE WITHOUT NOTICE. IT IS CONFIDENTIAL AND A PROPERTY OF Amphenol LTW. DISCLOSURE TO THIRD PARTY HAS TO BE AUTHORIZED BY Amphenol LTW.

REV.	ECN NO.	DATE	SIGN	DESCRIPTION

ALTW
CONFIDENTIAL
 2015-05-04
R&D DEPT.

ALTW
DCC. DEPT.
CONFIDENTIAL
 2015.05.12
ISSUED

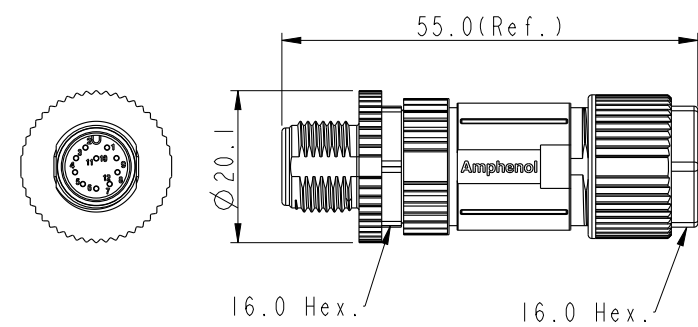
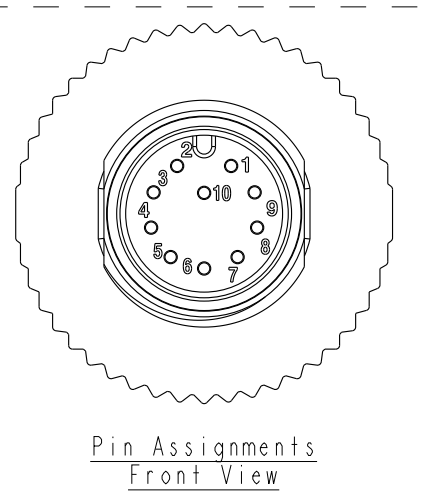
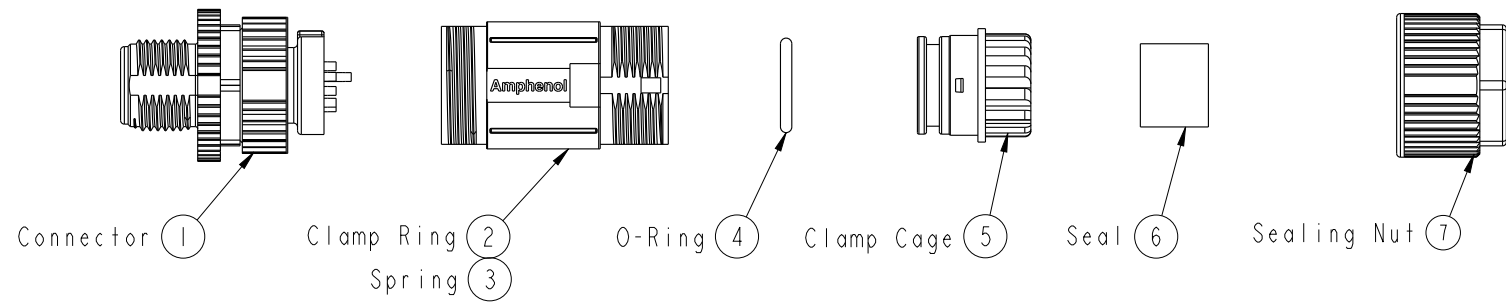

- Note:
- * Ⓢ Important Dimension To Check.
 - * Waterproof Rate: IP67
 - * Housing: Nylon, Black.
 - * Clamp Cage: Nylon, Black.
 - * Pin: Copper Alloy, Gold Plated.
 - * Nut: Zinc Alloy, Nickel Plated.
 - * O-Ring: Silicon, Grey.
 - * Clamp Ring: Zinc Alloy, Nickel Plated.
 - * Sealing Nut: Zinc Alloy, Nickel Plated.
 - * Seal: Silicon, Grey.
 - * Seal For Cable OD: $\varnothing 4.0\text{mm} \sim \varnothing 7.5\text{mm}$
 - * Applicable wire gauge (Stranded wire cross section) 26AWG ~24AWG
 - * Mating Recommended tightening torque: 3~4 kgf.cm / 0.29~0.39 N.m
 - * Sealing-Nut Recommended tightening torque: 4~6 kgf.cm / 0.39~0.59 N.m
 - * Detailed applicable wire specifications may vary depending on the actual wire construction.

UNIT:mm TOLERANCE .X ±0.25 .XX ±0.1 .XXX ±0.05 ANGLES ±1°	 TITLE M12A Shielded Assy 10Pin M Conn. M Pin	Amphenol LTW 安費諾亮泰企業股份有限公司		ITEM NO MSAS-10BMMMA-SL7001	DRAWN BY Yulong_wang	DATE 2015-05-04
		SCALE 1:1	SIZE A4	SHEET 1 OF 1	DWG NO MSAS-10BMMMA-SL7001	CHECKED BY Lu Di
REV. A	WC-REV. A.5	Ⓢ : Inspection item	CUSTOMER ALTW	APPROVED BY Jerry	DATE 2015-05-04	8 FMW10702-01-02A1