

PART NAME: KNOB SCALE: 1:1 DATE: 1/29/97 DR. BY HD

DAVIES MOLDING COMPANY
CAROL STREAM, ILLINOIS 60188

P/N 1202BP

THIS DRAWING IS THE PROPERTY OF DAVIES MOLDING COMPANY, IS SUBMITTED SOLELY AS A DESIGN OR ENGINEERING PROJECT. WE ACCEPT NO RESPONSIBILITY WHATSOEVER FOR THE PRACTICAL APPLICATION OF THE PIECES MADE TO THIS DESIGN.

BASE PART	1202-10
INSERT	I0456
SET SCREW	I0357
CAP INLAY	I0786-SCL

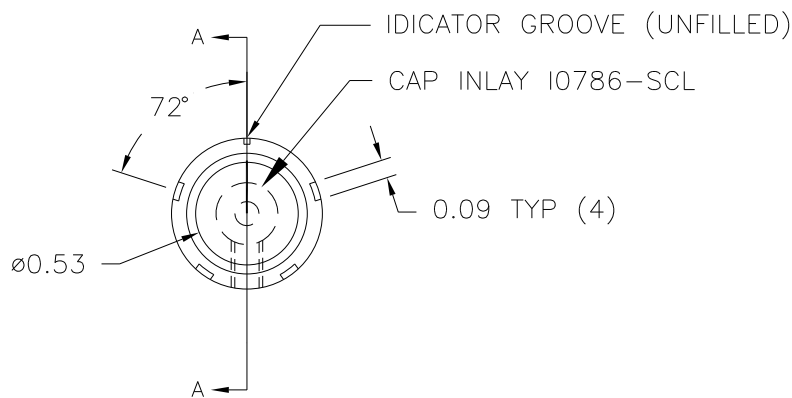

USE #28 DRILL (ø0.140), #8-32 TAP,
#8-32 X 1/4 LG. CUP POINTED,
SLOTTED TYPE, SET SCREW, I0357

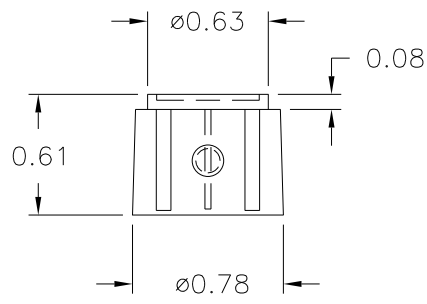

SECTION A-A

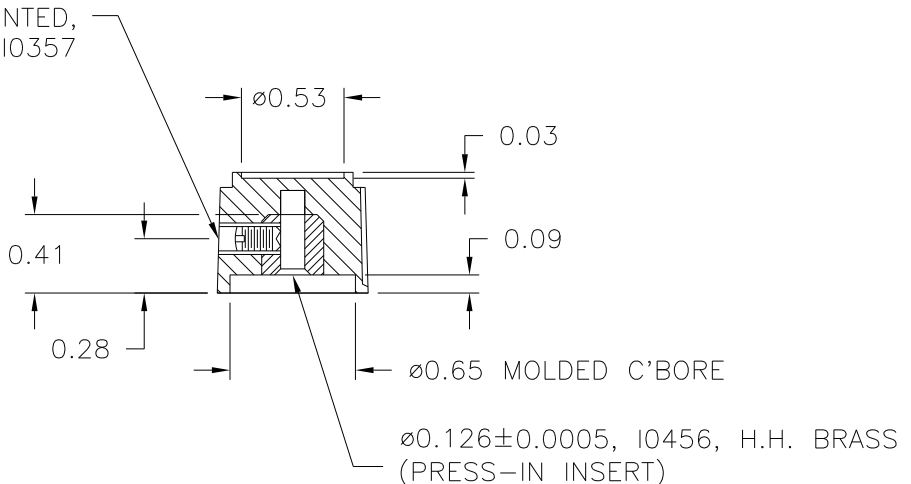

NOTE: ALL MOLDED PARTS MUST BE CHECKED WITH PIN GAUGE.
0.322/0.320 PIN MUST ACCEPT MOLDED HOLE
MATERIAL: G.P. PHENOLIC (B11)
COLOR: BLACK

TOLERANCES: UNLESS OTHERWISE SPECIFIED	DO NOT SCALE DRAWING				
DECIMALS: X.XXX ± .005 X.XX ± .015	MM: X.XX ± 0.15MM X.X ± 0.4MM	-	UPDATED/HAD TOOLBOX	ST	4/6/2000
FRACTIONS ± 1/64	ANG. ± 1°	CHANGES			

PART NAME: KNOB SCALE: 1:1 DATE: 1/29/97 DR. BY HD

THIS DRAWING IS THE PROPERTY OF DAVIES MOLDING COMPANY, IS SUBMITTED SOLELY AS A DESIGN OR ENGINEERING PROJECT. WE ACCEPT NO RESPONSIBILITY WHATSOEVER FOR THE PRACTICAL APPLICATION OF THE PIECES MADE TO THIS DESIGN.

DAVIES MOLDING COMPANY
CAROL STREAM, ILLINOIS 60188

P/N 1202BP	
BASE PART	1202-10
INSERT	I0456
SET SCREW	I0357
CAP INLAY	I0786-SCL

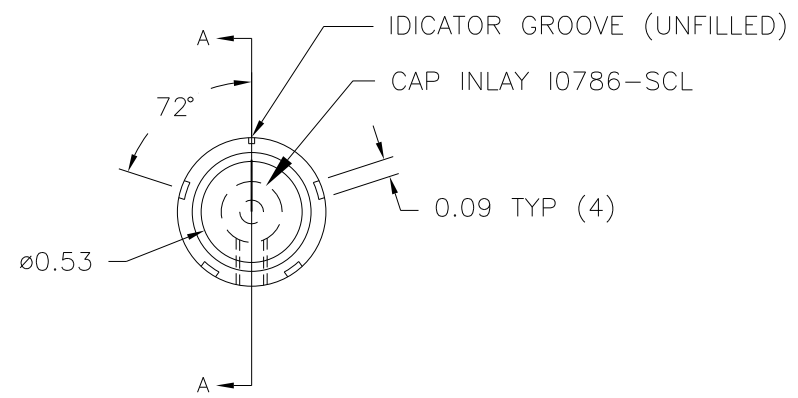

USE #28 DRILL ($\phi 0.140$), #8-32 TAP,
#8-32 X 1/4 LG. CUP POINTED,
SLOTTED TYPE, SET SCREW, I0357

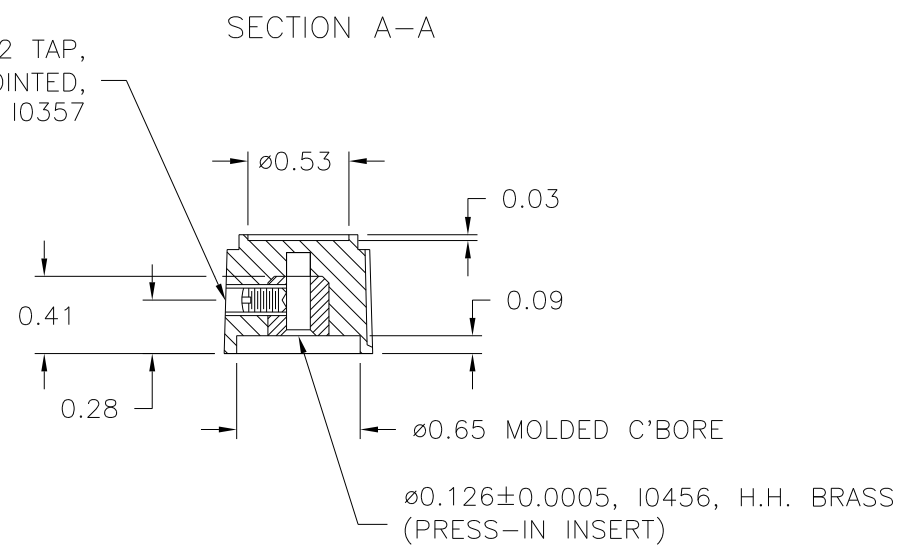
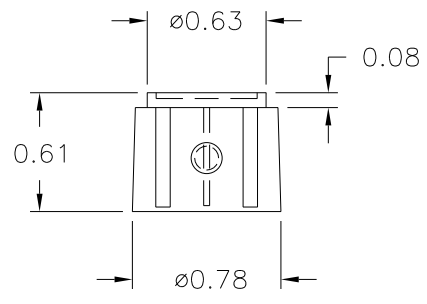

NOTE: ALL MOLDED PARTS MUST BE CHECKED WITH PIN GAUGE.
0.322/0.320 PIN MUST ACCEPT MOLDED HOLE
MATERIAL: G.P. PHENOLIC (B11)
COLOR: BLACK

TOLERANCES: UNLESS OTHERWISE SPECIFIED	DO NOT SCALE DRAWING			
DECIMALS: X.XXX ± .005 X.XX ± .015	MM: X.XX ± 0.15MM X.X ± 0.4MM	-	UPDATED/HAD TOOLBOX	ST 4/6/2000
FRACTIONS ± 1/64	ANG. ± 1°	CHANGES		