



## **PI7C9X2G308GP**

### **PCI EXPRESS GEN 2 PACKET SWITCH 3-Port/ 8-Lane PCI Express Gen 2 Switch Green Package Family**

*DATASHEET*

REVISION 6

December 2020

**DIODES**  
I N C O R P O R A T E D<sup>®</sup>

A Product Line of  
Diodes Incorporated

 **PERICOM**<sup>®</sup>

1545 Barber Lane Milpitas, CA 95035

Telephone: 408-232-9100

FAX: 408-434-1040

Internet: <http://www.diodes.com>

**IMPORTANT NOTICE**

1. DIODES INCORPORATED AND ITS SUBSIDIARIES (“DIODES”) MAKE NO WARRANTY OF ANY KIND, EXPRESS OR IMPLIED, WITH REGARDS TO ANY INFORMATION CONTAINED IN THIS DOCUMENT, INCLUDING, BUT NOT LIMITED TO, THE IMPLIED WARRANTIES OF MERCHANTABILITY, FITNESS FOR A PARTICULAR PURPOSE OR NON-INFRINGEMENT OF THIRD PARTY INTELLECTUAL PROPERTY RIGHTS (AND THEIR EQUIVALENTS UNDER THE LAWS OF ANY JURISDICTION).

2. The Information contained herein is for informational purpose only and is provided only to illustrate the operation of Diodes products described herein and application examples. Diodes does not assume any liability arising out of the application or use of this document or any product described herein. This document is intended for skilled and technically trained engineering customers and users who design with Diodes products. Diodes products may be used to facilitate safety-related applications; however, in all instances customers and users are responsible for (a) selecting the appropriate Diodes products for their applications, (b) evaluating the suitability of the Diodes products for their intended applications, (c) ensuring their applications, which incorporate Diodes products, comply the applicable legal and regulatory requirements as well as safety and functional-safety related standards, and (d) ensuring they design with appropriate safeguards (including testing, validation, quality control techniques, redundancy, malfunction prevention, and appropriate treatment for aging degradation) to minimize the risks associated with their applications.

3. Diodes assumes no liability for any application-related information, support, assistance or feedback that may be provided by Diodes from time to time. Any customer or user of this document or products described herein will assume all risks and liabilities associated with such use, and will hold Diodes and all companies whose products are represented herein or on Diodes’ websites, harmless against all damages and liabilities.

4. Products described herein may be covered by one or more United States, international or foreign patents and pending patent applications. Product names and markings noted herein may also be covered by one or more United States, international or foreign trademarks and trademark applications. Diodes does not convey any license under any of its intellectual property rights or the rights of any third parties (including third parties whose products and services may be described in this document or on Diodes’ website) under this document.

5. Diodes products are provided subject to Diodes’ Standard Terms and Conditions of Sale (<https://www.diodes.com/about/company/terms-and-conditions/terms-and-conditions-of-sales/>) or other applicable terms. This document does not alter or expand the applicable warranties provided by Diodes. Diodes does not warrant or accept any liability whatsoever in respect of any products purchased through unauthorized sales channel.

6. Diodes products and technology may not be used for or incorporated into any products or systems whose manufacture, use or sale is prohibited under any applicable laws and regulations. Should customers or users use Diodes products in contravention of any applicable laws or regulations, or for any unintended or unauthorized application, customers and users will (a) be solely responsible for any damages, losses or penalties arising in connection therewith or as a result thereof, and (b) indemnify and hold Diodes and its representatives and agents harmless against any and all claims, damages, expenses, and attorney fees arising out of, directly or indirectly, any claim relating to any noncompliance with the applicable laws and regulations, as well as any unintended or unauthorized application.

7. While efforts have been made to ensure the information contained in this document is accurate, complete and current, it may contain technical inaccuracies, omissions and typographical errors. Diodes does not warrant that information contained in this document is error-free and Diodes is under no obligation to update or otherwise correct this information. Notwithstanding the foregoing, Diodes reserves the right to make modifications, enhancements, improvements, corrections or other changes without further notice to this document and any product described herein. This document is written in English but may be translated into multiple languages for reference. Only the English version of this document is the final and determinative format released by Diodes.

8. Any unauthorized copying, modification, distribution, transmission, display or other use of this document (or any portion hereof) is prohibited. Diodes assumes no responsibility for any losses incurred by the customers or users or any third parties arising from any such unauthorized use.

Copyright © 2020 Diodes Incorporated

[www.diodes.com](http://www.diodes.com)

## REVISION HISTORY

Date	Revision Number	Description
04/08/13	0.1	Preliminary Datasheet
12/27/13	0.2	Updated Section 3 Pin Description Updated Section 11 Package Information Added Section 7 Register and Description Updated Section 3.2 Port Specific Signals Updated Section 1 Features Updated Section 12 Ordering Information Added Section 4.1 Pin List of 196-Pin LBGA Updated Section 4.2 Pin Map of 196-Pin LBGA Updated Section 8 Clock Scheme Updated Section 10.3 Power Consumption
06/03/14	1.0	Updated Section 1 Features Updated Section 2 General Description Updated Section 3.1 PCI Express Interface Signals Updated Section 3.2 Port Specific Signals Updated Section 3.3 EEPROM Signals Updated Section 3.4 Miscellaneous Signals Updated Section 4.1 Pin List of 196-Pin LBGA Updated Section 4.2 Pin Map of 196-Pin LBGA Updated Section 6 EEPROM Interface And System Management Bus Updated Section 6.1 EEPROM Interface Updated Section 6.2 SMBus Interface (Delete) Updated Section 7.2 Transparent Mode Configuration Registers Updated Section 8 Clock Scheme Updated Section 9 Power Management Updated Section 10.3 Power Consumption
10/21/14	1.1	Added Section 6.2 SMBUS Interface Added Section 6.3 I2C Slave Interface Added Section 8 Clock Scheme Updated Section 1 Features Updated Section 2 General Description Updated Section 3.2 Port Specific Signals (6 balls) Updated Section 3.3 EEPROM and SMBus/I2C Signals (6 balls) Updated Section 3.4 Miscellaneous Signals (24 balls) Updated Section 4.1 Pin List of 196-Pin LBGA Updated Section 6 EEPROM Interface and System Management/I2C Bus Updated Section 6.1 EEPROM Interface Updated Section 6.2 SMBus Interface Updated Section 6.3 I2C Slave Interface Updated Section 7.2 Transparent Mode Configuration Registers Updated Section 8 Clock Scheme
12/11/14	1.2	Updated Section Features Updated Section 8.2 AC Switching Characteristics
01/26/15	1.3	Updated Section 6.2 SMBus Interface Updated Section 6.3 I2C Slave Interface Updated Section 12 Ordering Information Updated Section 10.3 Power Consumption
08/20/15	1.4	Updated Section 3.1 PCI Express Interface Signals (66 balls) Updated Section 3.2 Port Specific Signals (4 balls) Updated Section 5.1 Physical Layer Circuit Updated Section 6.1 EEPROM Interface Updated Section 6.3 I2C Slave Interface Updated Section 7.2 Transparent Mode Configuration Registers Updated Section 8 Clock Scheme Updated Section 10.2 DC Specifications Deleted Section 10.5 AC Switching Characteristics of Clock Buffer
09/15/15	1.5	Updated Table 10-1 Absolute Maximum Ratings

12/23/15	1.6	<p>Updated Section 3 Pin Description</p> <p>Updated Table 6-5 SMBUS Block Write Portion</p> <p>Updated Figure 6-11/ 6-13 I<sup>2</sup>C Read Command Packet</p> <p>Updated Section 7.2.48 XPIP_CSR0 Register</p> <p>Updated Section 7.2.59 XPIP_CSR5 Register</p> <p>Updated Section 7.2.60 TL_CSR Register</p> <p>Updated Section 7.2.77 PCI Express Capabilities Register</p> <p>Updated Section 7.2.84 Slot Capabilities Register</p> <p>Updated Section 7.2.109 Port VC Capability Register 1</p> <p>Updated Table 10-1 Absolution Maximum Ratings</p> <p>Updated Table 10-2 DC Electrical Characteristics</p>
02/25/16	1.7	<p>Added Section 10 Power Sequence</p>
08/25/16	1.8	<p>Updated Section 1 Features</p> <p>Updated Section 4.1 Pin F2</p> <p>Updated Section 6.1.4 Mapping EEPROM Contents To Configuration Registers</p> <p>Updated Section 7.2.17 Memory Base Address Register – OFFSET 20h</p> <p>Updated Section 7.2.59 XPIP_CSR5 – OFFSET 88h</p> <p>Updated Section 7.2.63 OPERATION MODE – OFFSET 98h</p> <p>Updated Section 7.2.81 LINK CAPABILITIES REGISTER – OFFSET CCh</p> <p>Updated Section 7.2.83 Link Status Register – OFFSET D0h</p> <p>Updated Section 7.2.140 SMBUS Control Register – OFFSET 344h (Upstream Port Only)</p> <p>Updated Table 11.3 Power Consumption</p>
09/19/17	2-2	<p>Updated Section 3.3 EEPROM and SMBUS/I2C Signals (6 balls)</p> <p>Updated Section 6.1.4 Mapping EEPROM Contents to Configuration Registers</p> <p>Updated Section 7.2 Transparent Mode Configuration Registers</p> <p>Updated Table 8-3 Output Control For REFCLKOP/N [5:1]</p> <p>Updated Section 11.1 Absolute Maximum Ratings</p> <p>Updated Table 11-2 DC Electrical Characteristics</p> <p>Updated Table 11.3 Power Consumption</p> <p>Added Section 11.5 Operating Ambient Temperature</p> <p>Added Section 12 Thermal Data</p> <p>Revision numbering system changed to whole number</p>
01/12/18	3	<p>Updated Section 5.7 Transaction Ordering</p> <p>Updated Section 6 EEPROM Interface and System Management/I2C Bus</p> <p>Updated Section 7.2 TRANSPARENT MODE CONFIGURATION REGISTERS</p> <p>Updated Section 8 Clock Scheme</p> <p>Updated Section 14 Ordering Information</p> <p>Added Figure 13-2 Part Marking</p>
08/14/19	4	<p>Updated Section 1 Features</p> <p>Updated Section 3.2 PORT SPECIFIC SIGNALS (4 balls)</p> <p>Updated Section 6 EEPROM Interface</p> <p>Updated Section 8 CLOCK SCHEME</p> <p>Updated Section 11.1 Absolute Maximum Ratings</p> <p>Updated Figure 13-2 Part Marking</p>
04/09/20	5	<p>Updated Section 3.2 Port Specific Signals (4 balls)</p> <p>Updated Section 5.1 Physical Layer Circuit</p> <p>Updated Section 8 Clock Scheme</p> <p>Updated Section 14 Ordering Information</p> <p>Updated Figure 13-2 Part Marking</p>
12/15/20	6	<p>For Datasheet Status Change</p>

## TABLE OF CONTENT

<b>1</b>	<b>FEATURES</b> .....	<b>11</b>
<b>2</b>	<b>GENERAL DESCRIPTION</b> .....	<b>12</b>
<b>3</b>	<b>PIN DESCRIPTION</b> .....	<b>14</b>
3.1	PCI EXPRESS INTERFACE SIGNALS (66 BALLS).....	14
3.2	PORT SPECIFIC SIGNALS (4 BALLS).....	15
3.3	EEPROM AND SMBUS/I2C SIGNALS (6 BALLS).....	15
3.4	MISCELLANEOUS SIGNALS (42 BALLS).....	15
3.5	POWER PINS (78 BALLS).....	16
<b>4</b>	<b>PIN ASSIGNMENTS</b> .....	<b>17</b>
4.1	PIN LIST OF 196-PIN LPGA.....	17
4.2	PIN MAP OF 196-PIN LPGA.....	18
<b>5</b>	<b>FUNCTIONAL DESCRIPTION</b> .....	<b>19</b>
5.1	PHYSICAL LAYER CIRCUIT.....	19
5.1.1	RECEIVER DETECTION.....	19
5.1.2	RECEIVER SIGNAL DETECTION.....	20
5.1.3	RECEIVER EQUALIZATION.....	20
5.1.4	TRANSMITTER SWING.....	20
5.1.5	DRIVE AMPLITUDE AND DE-EMPHASIS SETTINGS.....	20
5.1.6	DRIVE AMPLITUDE.....	21
5.1.7	DRIVE DE-EMPHASIS.....	22
5.1.8	TRANSMITTER ELECTRICAL IDLE LATENCY.....	22
5.2	DATA LINK LAYER (DLL).....	22
5.3	TRANSACTION LAYER RECEIVE BLOCK (TLP DECAPSULATION).....	23
5.4	ROUTING.....	23
5.5	TC/VC MAPPING.....	23
5.6	QUEUE.....	23
5.6.1	PH.....	24
5.6.2	PD.....	24
5.6.3	NPHD.....	24
5.6.4	CPLH.....	24
5.6.5	CPLD.....	24
5.7	TRANSACTION ORDERING.....	24
5.8	PORT ARBITRATION.....	25
5.9	VC ARBITRATION.....	25
5.10	FLOW CONTROL.....	26
5.11	TRANSACTION LAYER TRANSMIT BLOCK (TLP ENCAPSULATION).....	26
<b>6</b>	<b>EEPROM INTERFACE AND SYSTEM MANAGEMENT/I2C BUS</b> .....	<b>27</b>
6.1	EEPROM INTERFACE.....	27
6.1.1	AUTO MODE EEPROM ACCESS.....	27
6.1.2	EEPROM MODE AT RESET.....	27
6.1.3	EEPROM SPACE ADDRESS MAP.....	27
6.1.4	MAPPING EEPROM CONTENTS TO CONFIGURATION REGISTERS.....	29
6.2	SMBUS INTERFACE.....	37
6.2.1	SMBUS BLOCK WRITE.....	38
6.2.2	SMBUS BLOCK READ.....	40
6.2.3	CSR READ, USING SMBUS BLOCK READ – BLOCK WRITE PROCESS CALL.....	42

6.3	I <sup>2</sup> C SLAVE INTERFACE.....	43
6.3.1	I <sup>2</sup> C REGISTER WRITE ACCESS.....	44
6.3.2	I <sup>2</sup> C REGISTER READ ACCESS.....	46
<b>7</b>	<b>REGISTER DESCRIPTION.....</b>	<b>49</b>
7.1	REGISTER TYPES .....	49
7.2	TRANSPARENT MODE CONFIGURATION REGISTERS .....	49
7.2.1	VENDOR ID REGISTER – OFFSET 00h .....	51
7.2.2	DEVICE ID REGISTER – OFFSET 00h.....	51
7.2.3	COMMAND REGISTER – OFFSET 04h.....	51
7.2.4	PRIMARY STATUS REGISTER – OFFSET 04h.....	52
7.2.5	REVISION ID REGISTER – OFFSET 08h .....	53
7.2.6	CLASS CODE REGISTER – OFFSET 08h.....	53
7.2.7	CACHE LINE REGISTER – OFFSET 0Ch.....	53
7.2.8	PRIMARY LATENCY TIMER REGISTER – OFFSET 0Ch .....	53
7.2.9	HEADER TYPE REGISTER – OFFSET 0Ch.....	53
7.2.10	PRIMARY BUS NUMBER REGISTER – OFFSET 18h .....	54
7.2.11	SECONDARY BUS NUMBER REGISTER – OFFSET 18h .....	54
7.2.12	SUBORDINATE BUS NUMBER REGISTER – OFFSET 18h .....	54
7.2.13	SECONDARY LATENCY TIMER REGISTER – OFFSET 18h.....	54
7.2.14	I/O BASE ADDRESS REGISTER – OFFSET 1Ch.....	54
7.2.15	I/O LIMIT ADDRESS REGISTER – OFFSET 1Ch.....	54
7.2.16	SECONDARY STATUS REGISTER – OFFSET 1Ch .....	55
7.2.17	MEMORY BASE ADDRESS REGISTER – OFFSET 20h .....	55
7.2.18	MEMORY LIMIT ADDRESS REGISTER – OFFSET 20h.....	55
7.2.19	PREFETCHABLE MEMORY BASE ADDRESS REGISTER – OFFSET 24h.....	56
7.2.20	PREFETCHABLE MEMORY LIMIT ADDRESS REGISTER – OFFSET 24h.....	56
7.2.21	PREFETCHABLE MEMORY BASE ADDRESS UPPER 32-BITS REGISTER – OFFSET 28h.....	56
7.2.22	PREFETCHABLE MEMORY LIMIT ADDRESS UPPER 32-BITS REGISTER – OFFSET 2Ch .....	56
7.2.23	I/O BASE ADDRESS UPPER 16-BITS REGISTER – OFFSET 30h.....	56
7.2.24	I/O LIMIT ADDRESS UPPER 16-BITS REGISTER – OFFSET 30h.....	57
7.2.25	CAPABILITY POINTER REGISTER – OFFSET 34h .....	57
7.2.26	INTERRUPT LINE REGISTER – OFFSET 3Ch.....	57
7.2.27	INTERRUPT PIN REGISTER – OFFSET 3Ch.....	57
7.2.28	BRIDGE CONTROL REGISTER – OFFSET 3Ch.....	57
7.2.29	POWER MANAGEMENT CAPABILITY REGISTER – OFFSET 40h .....	58
7.2.30	POWER MANAGEMENT DATA REGISTER – OFFSET 44h.....	58
7.2.31	PPB SUPPORT EXTENSIONS – OFFSET 44h.....	59
7.2.32	DATA REGISTER – OFFSET 44h.....	59
7.2.33	MSI CAPABILITY REGISTER – OFFSET 4Ch (Downstream Port Only) .....	59
7.2.34	MESSAGE CONTROL REGISTER – OFFSET 4Ch (Downstream Port Only) .....	59
7.2.35	MESSAGE ADDRESS REGISTER – OFFSET 50h (Downstream Port Only).....	60
7.2.36	MESSAGE UPPER ADDRESS REGISTER – OFFSET 54h (Downstream Port Only) .....	60
7.2.37	MESSAGE DATA REGISTER – OFFSET 58h (Downstream Port Only).....	60
7.2.38	VPD CAPABILITY ID REGISTER – OFFSET 5Ch (Upstream Port Only).....	60
7.2.39	VPD REGISTER – OFFSET 5Ch (Upstream Port Only).....	60
7.2.40	VPD DATA REGISTER – OFFSET 60h (Upstream Port Only) .....	61
7.2.41	VENDOR SPECIFIC CAPABILITY REGISTER – OFFSET 64h.....	61
7.2.42	XPIP_CSR0 – OFFSET 68h (Test Purpose Only) .....	61
7.2.43	XPIP_CSR1 – OFFSET 6Ch (Test Purpose Only).....	62
7.2.44	REPLAY TIME-OUT COUNTER – OFFSET 70h .....	62
7.2.45	ACKNOWLEDGE LATENCY TIMER – OFFSET 70h .....	62
7.2.46	SWITCH OPERATION MODE – OFFSET 74h (Upstream Port Only).....	62
7.2.47	SWITCH OPERATION MODE – OFFSET 74h (Downstream Port Only).....	64
7.2.48	XPIP_CSR2 – OFFSET 78h .....	64

7.2.49	PHY PARAMETER 1 – OFFSET 78h (Upstream Port Only)	64
7.2.50	PHY PARAMETER 2 – OFFSET 7Ch	65
7.2.51	XPIP_CSR3 – OFFSET 80h	66
7.2.52	XPIP_CSR4 – OFFSET 84h (Upstream Port Only)	66
7.2.53	XPIP_CSR5 – OFFSET 88h	66
7.2.54	TL_CSR – OFFSET 8Ch	66
7.2.55	PHY PARAMETER 3 – OFFSET 90h	67
7.2.56	PHY PARAMETER 4 - OFFSET 94h (Upstream Port Only)	68
7.2.57	OPERATION MODE – OFFSET 98h	68
7.2.58	DEVICE SPECIFIC POWER MANAGEMENT EVENT– OFFSET 9Ch (Downstream Port Only)	68
7.2.59	EEPROM CONTROL REGISTER – OFFSET A0h (Upstream Port Only)	69
7.2.60	EEPROM ADDRESS REGISTER – OFFSET A4h (Upstream Port Only)	70
7.2.61	EEPROM DATA REGISTER – OFFSET A4h (Upstream Port Only)	70
7.2.62	DEBUGOUT CONTROL REGISTER – OFFSET A8h (Upstream Port Only)	70
7.2.63	DEBUGOUT DATA REGISTER – OFFSET ACh (Upstream Port Only)	70
7.2.64	SSID/SSVID CAPABILITY REGISTER – OFFSET B0h	70
7.2.65	SUBSYSTEM VENDOR ID REGISTER – OFFSET B4h	71
7.2.66	SUBSYSTEM ID REGISTER – OFFSET B4h	71
7.2.67	GPIO CONTROL REGISTER – OFFSET B8h (Upstream Port Only)	71
7.2.68	PCI EXPRESS CAPABILITY ID REGISTER – OFFSET C0h	73
7.2.69	DEVICE CAPABILITIES REGISTER – OFFSET C4h	73
7.2.70	DEVICE CONTROL REGISTER – OFFSET C8h	74
7.2.71	DEVICE STATUS REGISTER – OFFSET C8h	75
7.2.72	LINK CAPABILITIES REGISTER – OFFSET CCh	75
7.2.73	LINK CONTROL REGISTER – OFFSET D0h	76
7.2.74	LINK STATUS REGISTER – OFFSET D0h	77
7.2.75	SLOT CAPABILITIES REGISTER – OFFSET D4h (Downstream Port Only)	78
7.2.76	SLOT CONTROL REGISTER – OFFSET D8h (Downstream Port Only)	79
7.2.77	SLOT STATUS REGISTER – OFFSET D8h (Downstream Port Only)	80
7.2.78	DEVICE CAPABILITIES REGISTER 2 – OFFSET E4h	80
7.2.79	DEVICE CONTROL REGISTER 2 – OFFSET E8h	81
7.2.80	DEVIDE STATUS REGISTER 2 – OFFSET E8h	81
7.2.81	LINK CAPABILITIES REGISTER 2 – OFFSET ECh	81
7.2.82	LINK CONTROL REGISTER 2 – OFFSET F0h	81
7.2.83	LINK STATUS REGISTER 2 – OFFSET F0h	81
7.2.84	SLOT CAPABILITIES REGISTER 2 – OFFSET F4h	82
7.2.85	SLOT CONTORL REGISTER 2 – OFFSET F8h	82
7.2.86	SLOT STATUS REGISTER 2 – OFFSET F8h	82
7.2.87	PCI EXPRESS ADVANCED ERROR REPORTING CAPABILITY REGISTER – OFFSET 100h	82
7.2.88	UNCORRECTABLE ERROR STATUS REGISTER – OFFSET 104h	82
7.2.89	UNCORRECTABLE ERROR MASK REGISTER – OFFSET 108h	83
7.2.90	UNCORRECTABLE ERROR SEVERITY REGISTER – OFFSET 10Ch	84
7.2.91	CORRECTABLE ERROR STATUS REGISTER – OFFSET 110 h	85
7.2.92	CORRECTABLE ERROR MASK REGISTER – OFFSET 114 h	85
7.2.93	ADVANCE ERROR CAPABILITIES AND CONTROL REGISTER – OFFSET 118h	86
7.2.94	HEADER LOG REGISTER – OFFSET From 11Ch to 128h	86
7.2.95	PCI EXPRESS VIRTUAL CHANNEL CAPABILITY REGISTER – OFFSET 140h	86
7.2.96	PORT VC CAPABILITY REGISTER 1 – OFFSET 144h	86
7.2.97	PORT VC CAPABILITY REGISTER 2 – OFFSET 148h	87
7.2.98	PORT VC CONTROL REGISTER – OFFSET 14Ch	87
7.2.99	PORT VC STATUS REGISTER – OFFSET 14Ch	87
7.2.100	VC RESOURCE CAPABILITY REGISTER (0) – OFFSET 150h	88
7.2.101	VC RESOURCE CONTROL REGISTER (0) – OFFSET 154h	88
7.2.102	VC RESOURCE STATUS REGISTER (0) – OFFSET 158h	89
7.2.103	VC RESOURCE CAPABILITY REGISTER (1) – OFFSET 15Ch	89

7.2.104	VC RESOURCE CONTROL REGISTER (1) – OFFSET 160h .....	89
7.2.105	VC RESOURCE STATUS REGISTER (1) – OFFSET 164h.....	90
7.2.106	VC ARBITRATION TABLE REGISTER – OFFSET 170h.....	90
7.2.107	PORT ARBITRATION TABLE REGISTER (0) and (1) – OFFSET 180h and 1C0h.....	91
7.2.108	PCI EXPRESS POWER BUDGETING CAPABILITY REGISTER – OFFSET 20Ch .....	91
7.2.109	DATA SELECT REGISTER – OFFSET 210h .....	91
7.2.110	POWER BUDGETING DATA REGISTER – OFFSET 214h .....	92
7.2.111	POWER BUDGET CAPABILITY REGISTER – OFFSET 218h .....	92
7.2.112	ACS EXTENDED CAPABILITY HEADER – OFFSET 220h (Downstream Port Only) .....	92
7.2.113	ACS CAPABILITY REGISTER – OFFSET 224h (Downstream Port Only).....	93
7.2.114	EGRESS CONTROL VECTOR – OFFSET 228h (Downstream Port Only) .....	93
7.2.115	LTR EXTENDED CAPABILITY HEADER – OFFSET 230h (Upstream Port Only).....	94
7.2.116	MAX SNOOP LATENCY REGISTER – OFFSET 234h (Upstream Port Only) .....	94
7.2.117	MAX NO-SNOOP LATENCY REGISTER – OFFSET 234h (Upstream Port Only) .....	94
7.2.118	L1 PM SUBSTATES EXTENDED CAPABILITY HEADER – OFFSET 240h.....	94
7.2.119	L1 PM SUBSTATES CAPABILITY REGISTER – OFFSET 244h.....	94
7.2.120	L1 PM SUBSTATES CONTROL 1 REGISTER – OFFSET 248h.....	95
7.2.121	L1 PM SUBSTATES CONTROL 2 REGISTER – OFFSET 24Ch .....	95
7.2.122	LTSSM_CSR REGISTER – OFFSET 33Ch.....	95
7.2.123	HOTPLUG_CSR REGISTER – OFFSET 340h.....	95
7.2.124	MAC_CSRI REGISTER – OFFSET 340h.....	96
7.2.125	SMBUS CONTROL REGISTER – OFFSET 344h (Upstream Port Only).....	96
7.2.126	CPLD FLOW CONTRL ENABLE REGISTER– OFFSET 350h (Upstream Port Only).....	96
7.2.127	CPLD FLOW CONTROL THRESHOLD RGISTER – OFFSET 354h (Upstream Port Only).....	96
7.2.128	CPLD FLOW CONTROL THRESHOLD RGISTER – OFFSET 358h (Upstream Port Only).....	97
7.2.129	POWER DAVING DISABLE RGISTER – OFFSET 360h.....	97
7.2.130	LED DISPLAY CSR 364h (Upstream Port Only) .....	97
<b>8</b>	<b>CLOCK SCHEME .....</b>	<b>98</b>
<b>9</b>	<b>POWER MANAGEMENT .....</b>	<b>99</b>
<b>10</b>	<b>POWER SEQUENCE .....</b>	<b>100</b>
<b>11</b>	<b>ELECTRICAL AND TIMING SPECIFICATIONS .....</b>	<b>101</b>
11.1	ABSOLUTE MAXIMUM RATINGS .....	101
11.2	DC SPECIFICATIONS .....	101
11.3	AC SPECIFICATIONS .....	101
11.4	POWER CONSUMPTION.....	103
11.5	OPERATING AMBIENT TEMPERATURE .....	103
<b>12</b>	<b>THERMAL DATA .....</b>	<b>104</b>
<b>13</b>	<b>PACKAGE INFORMATION.....</b>	<b>105</b>
<b>14</b>	<b>ORDERING INFORMATION.....</b>	<b>106</b>



## LIST OF FIGURES

FIGURE 4-1 PI7C9X2G308GP BALL ASSIGNMENT (TRANSPARENT TOP VIEW) .....	18
FIGURE 5-1 DRIVER OUTPUT WAVEFORM .....	21
FIGURE 6-1 SMBUS ARCHITECTURE IMPLEMENTATION .....	37
FIGURE 6-2 SMBUS BLOCK WRITE COMMAND FORMAT, TO WRITE TO A PI7C9X2G308GP REGISTER WITHOUT PEC .....	38
FIGURE 6-3 SMBUS BLOCK WRITE COMMAND FORMAT, TO WRITE TO A PI7C9X2G308GP REGISTER WITH PEC ...	38
FIGURE 6-4 SMBUS BLOCK WRITE TO SET UP READ, AND RESULTING READ THAT RETURNS CFG REGISTER VALUE .....	40
FIGURE 6-5 CSR READ OPERATION USING SMBUS BLOCK READ – BLOCK WRITE PROCESS CALL .....	42
FIGURE 6-6 CSR READ OPERATION USING SMBUS BLOCK READ – BLOCK WRITE PROCESS CALL WITH PEC .....	42
FIGURE 6-7 STANDARD DEVICES TO I <sup>2</sup> C BUS CONNECTION BLOCK DIAGRAM .....	43
FIGURE 6-8 I <sup>2</sup> C WRITE PACKET .....	45
FIGURE 6-9 I <sup>2</sup> C REGISTER WRITE ACCESS EXAMPLE .....	45
FIGURE 6-10 I <sup>2</sup> C WRITE COMMAND PACKET EXAMPLE .....	46
FIGURE 6-11 I <sup>2</sup> C READ COMMAND PACKET .....	47
FIGURE 6-12 I <sup>2</sup> C REGISTER READ ACCESS EXAMPLE .....	48
FIGURE 6-13 I <sup>2</sup> C READ COMMAND PACKET .....	48
FIGURE 10-1 INITIAL POWER-UP SEQUENCE .....	100
FIGURE 13-1 PACKAGE OF DRAWING .....	105
FIGURE 13-2 PART MARKING .....	105

## LIST OF TABLES

TABLE 5-1 RECEIVER DETECTION THRESHOLD SETTINGS .....	19
TABLE 5-2 RECEIVER SIGNAL DETECT THRESHOLD .....	20
TABLE 5-3 RECEIVER EQUALIZATION SETTINGS .....	20
TABLE 5-4 TRANSMITTER SWING SETTINGS .....	20
TABLE 5-5 DRIVE AMPLITUDE BASE LEVEL REGISTERS.....	21
TABLE 5-6 DRIVE AMPLITUDE BASE LEVEL SETTINGS.....	21
TABLE 5-7 DRIVE DE-EMPHASIS BASE LEVEL REGISTER .....	22
TABLE 5-8 DRIVE DE-EMPHASIS BASE LEVEL SETTINGS .....	22
TABLE 5-9 SUMMARY OF PCI EXPRESS ORDERING RULES .....	25
TABLE 6-1 SMBUS ADDRESS PIN CONFIGURATION .....	37
TABLE 6-2 BYTES FOR SMBUS BLOCK WRITE .....	38
TABLE 6-3 SAMPLE SMBUS BLOCK WRITE BYTE SEQUENCE .....	39
TABLE 6-4 BYTES FOR SMBUS BLOCK READ.....	40
TABLE 6-5 SMBUS BLOCK WRITE PORTION .....	41
TABLE 6-6 SMBUS BLOCK READ PORTION .....	41
TABLE 6-7 SMBUS READ COMMAND FOLLOWING REPEAT START FROM MASTER .....	41
TABLE 6-8 SMBUS RETURN BYTES.....	42
TABLE 6-9 COMMAND FORMAT FOR SMBUS BLOCK READ .....	42
TABLE 6-10 I <sup>2</sup> C ADDRESS PIN CONFIGURATION.....	43
TABLE 6-11 I <sup>2</sup> C REGISTER WRITE ACCESS.....	44
TABLE 6-12 I <sup>2</sup> C COMMAND FORMAT FOR WRITE ACCESS.....	44
TABLE 6-13 I <sup>2</sup> C COMMAND FORMAT FOR READ ACCESS .....	46
TABLE 7-1 REGISTER ARRAY LAYOUT FOR VC ARBITRATION.....	90
TABLE 7-2 TABLE ENTRY SIZE IN 4 BITS.....	91
TABLE 8-1 DC ELECTRICAL CHARACTERISTICS .....	98
TABLE 8-2 DC ELECTRICAL CHARACTERISTICS .....	98
TABLE 11-1 ABSOLUTE MAXIMUM RATINGS .....	101
TABLE 11-2 DC ELECTRICAL CHARACTERISTICS .....	101
TABLE 11-3 PCI EXPRESS INTERFACE - DIFFERENTIAL TRANSMITTER (TX) OUTPUT (5.0 GBPS) CHARACTERISTICS	101
TABLE 11-4 PCI EXPRESS INTERFACE - DIFFERENTIAL TRANSMITTER (TX) OUTPUT (2.5 GBPS) CHARACTERISTICS	102
TABLE 11-5 PCI EXPRESS INTERFACE - DIFFERENTIAL RECEIVER (RX) INPUT (5.0 GBPS) CHARACTERISTICS .....	102
TABLE 11-6 PCI EXPRESS INTERFACE - DIFFERENTIAL RECEIVER (RX) INPUT (2.5 GBPS) CHARACTERISTICS .....	103
TABLE 11-7 POWER CONSUMPTION.....	103
TABLE 11-8 OPERATING AMBIENT TEMPERATURE.....	103
TABLE 12-1 THERMAL DATA.....	104

# 1 FEATURES

- 8-lane PCI Express Gen 2 Switch with 3 PCI Express ports
- Supports “Cut-through”(Default) as well as “Store and Forward” mode for packet switching
- Peer-to-peer switching between any two downstream ports
- 150 ns typical latency for packet routed through Switch without blocking
- Integrated reference clock for downstream ports
- Register configurable with optional EEPROM, SMBus or I2C
- Compliant with *System Management (SM) Bus Revision 2.0*
- Compliant with *I2C-Bus Specification Revision 2.1*
- Compliant with *PCI Express Base Specification Revision 2.1*
- Compliant with *PCI Express CEM Specification Revision 2.0*
- Compliant with *PCI-to-PCI Bridge Architecture Specification Revision 1.2*
- Compliant with *Advanced Configuration Power Interface (ACPI) Specification*
- Reliability, Availability and Serviceability
  - Supports Data Poisoning and End-to-End CRC
  - Advanced Error Reporting and Logging
- Advanced Power Saving
  - Empty downstream ports are set to idle state to minimize power consumption
- Link Power Management
  - Supports L0, L0s, L1, L2, L2/L3<sub>Ready</sub> and L3 link power states
  - Active state power management for L0s and L1 states
- Device State Power Management
  - Supports D0, D3<sub>Hot</sub> and D3<sub>Cold</sub> device power states
- Supports Device Specific PME Turn-Off Message for each downstream port
- Port Arbitration: Round Robin (RR), Weighted RR and Time-based Weighted RR
- Extended Virtual Channel capability
  - Two Virtual Channels (VC) and Eight Traffic Class (TC) support
  - Disabled VCs’ buffer is assigned to enabled VCs for resource sharing
  - Independent TC/VC mapping for each port
  - Provides VC arbitration selections: Strict Priority, Round Robin (RR) and Programmable Weighted RR
- Supports Isochronous Traffic
  - Isochronous traffic class mapped to VC1 only
  - Strict time based credit policing
- Supports up to 512-byte maximum payload size
- Programmable driver current and de-emphasis level at each individual port
- Support Address Translation (AT) and Access Control Service (ACS)
- Support OBFF and LTR
- Support Serial Hot Plug Controller
- Low Power Dissipation: 0.9 W typical in L0 normal mode (Including clock buffer Pd)
- Industrial Temperature Range -40° to 85°C
- Totally Lead-Free & Fully RoHS Compliant (Notes 1 & 2)
- Halogen and Antimony Free. “Green” Device (Note 3)
- For automotive applications requiring specific change control (i.e. parts qualified to AEC-Q100/101/200, PPAP capable, and manufactured in IATF 16949 certified facilities), please [contact us](#) or your local Diodes representative.
- <https://www.diodes.com/quality/product-definitions/>
- 196-pin LBGA 15mm x 15mm package

Notes:

1. No purposely added lead. Fully EU Directive 2002/95/EC (RoHS), 2011/65/EU (RoHS 2) & 2015/863/EU (RoHS 3) compliant.
2. See <https://www.diodes.com/quality/lead-free/> for more information about Diodes Incorporated’s definitions of Halogen- and Antimony-free, “Green” and Lead-free.
3. Halogen- and Antimony-free “Green” products are defined as those which contain <900ppm bromine, <900ppm chlorine (<1500ppm total Br + Cl) and <1000ppm antimony compounds.

## 2 GENERAL DESCRIPTION

Similar to the role of PCI/PCIX Bridge in PCI/PCIX bus architecture, the function of PCI Express (PCIE) Switch is to expand the connectivity to allow more end devices to be reached by host controllers in PCIE serial interconnect architecture. The 8-lane PCIE Switch is in 3-port type configuration. It provides users the flexibility to expand or fan-out the PCI Express lanes based on their application needs.

In the PCI Express Architecture, the PCIE Switch forwards posted and non-posted requests, and completion packets in either downstream or upstream direction concurrently as if a virtual PCI Bridge is in operation on each port. By visualizing the port as a virtual Bridge, the Switch can be logically viewed as two-level cascaded multiple virtual PCI-to-PCI Bridges, where one upstream-port Bridge sits on all downstream-port Bridges. Similar to a PCI Bridge during enumeration, each port is given a unique bus number, device number, and function number by the initiating software. The bus number, device number, and function number are combined to form a destination ID for each specific port. In addition to that, the memory-map and IO address ranges are exclusively allocated to each port as well. After the software enumeration is finished, the packets are routed to the dedicated port based on the embedded address or destination ID. To ensure the packet integrity during forwarding, the Switch is not allowed to split the packets to multiple small packets or merge the received packets into a large transmit packet. Also, the IDs of the requesters and completers are kept unchanged along the path between ingress and egress port.

The Switch employs the architecture of Combined Input and Output Queue (CIOQ) in implementation. The main reason for choosing CIOQ is that the required memory bandwidth of input queue equals to the bandwidth of ingress port rather than increasing proportionally with port numbers as an output queue Switch does. The CIOQ at each ingress port contains separate dedicated queues to store packets. The packets are arbitrated to the egress port based on the PCIE transaction-ordering rule. For the packets without ordering information, they are permitted to pass over each other in case that the addressed egress port is available to accept them. As to the packets required to follow the ordering rule, the Head-Of-Line (HOL) issue becomes unavoidable for packets destined to different egress ports since the operation of producer-consumer model has to be retained; otherwise the system might occur hang-up problem. On the other hand, the Switch places replay buffer at each egress port to defer the packets before sending it out. This can assure the maximum throughput being achieved and therefore the Switch works efficiently. Another advantage of implementing CIOQ in PCIE Switch is that the credit announcement to the counterpart is simplified and streamlined because of the credit-based flow control protocol. The protocol requires that each ingress port maintains the credits independently without checking other ports' credit availability, which is otherwise required by pure output queue architecture.

The Switch supports two virtual channels (VC0, VC1) and eight traffic classes (TC0 ~ TC7) at each port. The ingress port independently assigns packets into the preferred virtual channel while the egress port outputs the packet based on the predefined port and VC arbitration algorithm. For instance, the isochronous packet is given a special traffic class number other than TC0 and mapped into VC1 accordingly. By employing the strict time based credit policy for port arbitration and assigning higher priority to VC1 than VC0, the Switch can therefore guarantee the time-sensitive packet is not blocked by regular traffic to assure the quality of service. In addition, some data-centric applications only carry TC0/VC0 traffic. As a result, there are no packets that would consume VC1 bandwidth. In order to improve the efficiency of buffer usage, the unused VC1 queues can be reassigned to VC0 and enable each of the ingress ports to handle more data traffic bursts. This virtual channel resource relocation feature enhances the performance of the PCIE Switch further.

The Switch provides the advanced feature of Access Control Service (ACS). This feature regulates which components are allowed to communicate with each other within the PCIE multiple-point fabric, and allows the system to have more control over packet routing in the Switch. As a result, peer-to-peer traffic can be facilitated more accurately and efficiently. When the system also implements Address Translation Service (ATS), the peer-to-peer requests with translated address can be routed directly by enabling the corresponding option in ACS to avoid possible performance bottleneck associated with re-direction, which introduces extra latency and may increase link and RC congestion.

The built-in Integrated Reference Clock Buffer of the PCI Express Switch supports seven reference clock outputs. The clock buffer is from a single 100MHz clock input, and distributes the clock source to seven outputs, which can be used by the PCI Express Switch and downstream PCI Express end devices. The clock buffer feature can be enabled and disabled by strapping pin setting.

The PI7C9X2G308GP supports various types of power management ranged from device state, link state to platform-wise power saving mechanism. For device state, the D0, D1, D2, D3-hot, and D3-cold power states represent different amount of power dissipation in PI7C9X2G308GP. As to link state, each link of the PI7C9X2G308GP supports the PCI Express Link Power Management with L0, L0s, L1, L2/L3 ready and L2/L3 power states. In addition, PCI-PM L1.1 of L1 PM Substate and device-specific L2/L3 are implemented to reduce power consumption further. The PI7C9X2G308GP is also designed to facilitate platform-wise power saving by enabling the capability of Latency Tolerance Reporting (LTR) and Optimized Buffer Flush/Fill (OBFF) mechanisms to synchronize both Root Complex and Device entering or leaving power down state almost in the same time window to make power saving much efficient.

### 3 PIN DESCRIPTION

#### 3.1 PCI EXPRESS INTERFACE SIGNALS (66 balls)

NAME	PIN	TYPE	DESCRIPTION
REFCLKP[2:0] REFCLKN[2:0]	G2, B8, N7 G1, A8, P7	I	<b>Reference Clock Input Pairs:</b> Connect to 100MHz differential clock when integrated reference clock buffer is disabled (CLKBUF_PD=1), or connect to one of the Integrated Reference Clock Output Pairs (REFCLKO_P and REFCLKO_N) of this Switch when integrated reference clock buffer is enabled (CLKBUF_PD=0).  The input clock signals must be delivered to the clock buffer cell through an AC-coupled interface so that only the AC information of the clock is received, converted, and buffered. It is recommended that a 0.1uF be used in the AC-coupling.
PERP[3:0] PERP[5:4] PERP[9:8]	P12, P10, P5, P3 A10, A12 E1, C1	I	<b>PCI Express Data Serial Input Pairs:</b> Differential data receive signals in three ports.  Port 0 is PERP[3:0] and PERN[3:0] Port 1 is PERP[5:4] and PERN[5:4] Port 2 is PERP[9:8] and PERN[9:8]
PERN[3:0] PERN[5:4] PERN[9:8]	N12, N10, N5, N3 B10, B12 E2, C2	I	
PETP[3:0] PETP[5:4] PETP[9:8]	P11, P9, P6, P4 A9, A11 F1, D1	O	
PETN[3:0] PETN[5:4] PETN[9:8]	N11, N9, N6, N4 B9, B11 F2, D2	O	<b>PCI Express Data Serial Output Pairs:</b> Differential data transmit signals in three ports.  Port 0 is PETP[3:0] and PETN[3:0] Port 1 is PETP[5:4] and PETN[5:4] Port 2 is PETP[9:8] and PETN[9:8]
PERST_L	M13	I	<b>System Reset (Active LOW):</b> When PERST_L is asserted, the internal states of whole chip are initialized.  Please refer to Table 10-2 for PERST_L Spec.
DWNRST_L[2:1]	P13, P14	O	<b>Downstream Device Reset (Active LOW):</b> DWNRST_L provides a reset signal to the devices connected to the downstream ports of the switch. The signal is active when either PERST_L is asserted or controlled by high-level program when recovering from device specific L2/L3 state. DWNRST_L [x] corresponds to Portx, where x= 1,2
REXT[2:0]	H1, A7, P8	I	<b>External Reference Resistor:</b> Connect an external resistor (1.43K Ohm +/- 1%) to REXT_GND to provide a reference to both the bias currents and impedance calibration circuitry.
REXTGND[2:0]	H2, B7, N8	I	<b>External Reference Resistor Ground:</b> Connect to an external resistor to REXT.
REFCLKIP, REFCLKIN	G13, G14	I	<b>Integrated Reference Clock Input Pair:</b> Connect to external 100MHz differential clock for the integrated reference clock buffer.
REFCLKOP[7:1]	L13, K13, J13, H13, F13, E13, D13	O	<b>Integrated Reference Clock Output Pairs:</b> 100MHz external differential HCSL clock outputs for the integrated reference clock buffer.  By default, REFCLKOP/N[5:1] are turn on. REFCLKOP/N[7:6] need be turn on by EEPROM.
REFCLKON[7:1]	L14, K14, J14, H14, F14, E14, D14	O	
IREF	E12	I	<b>Differential Reference Clock Output Current Resistor:</b> External resistor (475 Ohm +/- 1%) connection to set the differential reference clock output current
CLKBUF_PD	P2	I	<b>Reference Clock Output Pairs Power Down:</b> When CLKBUF_PD is asserted high, the integrated reference clock buffer and Reference Clock Outputs are disabled. This pin has internal pull-down resistor. If no board trace is connected to this pin, the internal pull-down resistor of this pin is enough. However, if pin is connected to a board trace and not driven, it is recommended that an external 330-ohm pull-down resistor be used.
SWG_LVL	J12	I	<b>Output Swing Level:</b> It controls the HCSL output level. When asserted, the nominal swing level is 700mV. When deasserted, the nominal swing level is 400mV. This pin has internal pull-up resistor. If no board trace

NAME	PIN	TYPE	DESCRIPTION
			is connected to this pin, the internal pull-up resistor of this pin is enough. However, if pin is connected to a board trace and not driven, it is recommended that an external 5.1K-ohm pull-up resistor be used.

### 3.2 PORT SPECIFIC SIGNALS (4 balls)

NAME	PIN	TYPE	DESCRIPTION
CLKREQ_L[3:1]	B14, C13, C14	I	<b>Clock Request (Active Low):</b> If want to enable related reference clock outputs, pull down these pins. If want to disable reference clock outputs, it can be done by cfg offset 98h.
PL_512B	K3	I	<b>Max. Payload Size 512B:</b> When PL_512B is asserted high, it indicates the max. payload size capability is 512B. Otherwise, it indicates the max. Payload size is 256B. This pin has internal pull-down resistor. If no board trace is connected to this pin, the internal pull-down resistor of this pin is enough. However, if pin is connected to a board trace and not driven, it is recommended that an external 330-ohm pull-down resistor be used.

### 3.3 EEPROM AND SMBUS/I2C SIGNALS (6 balls)

NAME	PIN	TYPE	DESCRIPTION
EECK	L12	I/O	<b>EEPROM Clock:</b> Clock signal to 4-wire EEPROM interface.
EEDI	M11	O	<b>EEPROM Data Input:</b> Pericom 2G308GP outputs data to the Data Input pin of Serial EEPROM.
EEDO	K12	I	<b>EEPROM Data Output:</b> Pericom 2G308GP inputs data from the Data Output pin of Serial EEPROM.
EECS_L	*M12	I/O	<b>EEPROM Chip Select (Active Low):</b> Pericom 2G308GP asserts this signal to enable Serial EEPROM.  <b>EEPROM Bypass Mode (EEPROM_BYPASS_L):</b> During system initialization, EECS_L acts as the EEPROM_BYPASS_L pin. When tied low, eeprom function is disabled. When tied high, eeprom function is enabled. The pin has internal pull-up resistor. If no board trace is connected to this pin, the internal pull-up resistor of this pin is enough. However, if pin is connected to a board trace and not driven, it is recommended that an external 5.1K-ohm pull-up resistor be used.
SCL_I2C	J11	OD	<b>SMBUS/I2C Serial Clock:</b> System management or I2C Bus Clock. This pin requires an external 5.1K-ohm pull-up resistor.
SDA_I2C	K11	OD	<b>SMBUS/I2C Serial Data:</b> Bi-Directional System Management or I2C Bus Data. This pin requires an external 5.1K-ohm pull-up resistor.

### 3.4 MISCELLANEOUS SIGNALS (42 balls)

NAME	PIN	TYPE	DESCRIPTION
SHCL_I2C	A13	OD	<b>I2C Clock Signal of Serial Hot Plug Controller:</b> It is connected to SCL pin of all I2C IO expanders.
SHDA_I2C	A14	OD	<b>I2C Data Signal of Serial Hot Plug Controller:</b> It is connected to SDA pin of all I2C IO expanders.
SHPCINT_L	B13	I	<b>Interrupt Input (Active Low) of Serial Hot Plug Controller:</b> It is connected to INT# output pin of all I2C IO expanders. When asserted, it notifies Hot Plug Controller to access the port registers of all I/O expanders for touching changed status to de-assert INT#.

NAME	PIN	TYPE	DESCRIPTION
GPIO[7:0]	D3, C3, C4, C5, B1, B2, A1, A2	I/O	<p><b>General Purpose Input and Output:</b> These eight general-purpose pins are programmed as either input-only or bi-directional pins by writing the GPIO output enable control register. When SMBus is implemented, GPIO [7:5] act as the SMBus address pins, which set Bit 2 to 0 of the SMBus address.</p> <p><b>Debug Mode Selection:</b> In debug mode, GPIO[4:0] are used for Debug Mode Selection.</p>
DBO[4:0]	N1, M4, *M3, *L3, *K3	O	<p><b>Debugout Pins:</b> These signals will output internal debug status. Please connect to test pin header for debug used.</p> <p><b>Operation Mode Selection (OPMode_Sel):</b> During system initialization, DBO[2:0] acts as the OPMode_Sel[2:0] pins. When tied low, it is in the normal mode. These pins have internal pull-down resistors. If no board trace is connected to these pins, the internal pull-down resistors of these pins are enough. However, if pins are connected to a board trace and not driven, it is recommended that external 330-ohm pull-down resistors be used.</p> <p>DBO[0] shares with PL_512B pin.</p>
NC	A3, A4, A5, A6, B3, B4, B5, B6, C7, C11, C12, D12, H3, J1, J2, K1, K2, L1, L2, M1, M2, M8, M14, N2, N13, N14, P1		<p><b>Not Connected:</b> These pins can be just left open.</p>

### 3.5 POWER PINS (78 balls)

NAME	PIN	TYPE	DESCRIPTION
VDDC	D5, D6, D9, D10, E4, E11, F4, F11, G11, H11, J4, K4, L5, L6, L9, L10	P	<b>VDDC Supply (1.0V):</b> Used as digital core power pins.
VDDR	D4, D11, L4, L11	P	<b>VDDR Supply (3.3V):</b> Used as digital I/O power pins.
CVDDR	F12, G12, H12	P	<b>CVDDR Supply (3.3V):</b> Used as reference clock power pin.
AVDD	D7, D8, G4, H4, L7, L8	P	<b>AVDD Supply (1.0V):</b> Used as PCI Express analog power pins.
AVDDH	C8, G3, M7	P	<b>AVDDH Supply (3.3V):</b> Used as PCI Express analog high voltage power pins.
AGND	C6, C9, C10, E3, F3, J3, M5, M6, M9, M10	P	<b>Analog Ground:</b> Used as analog ground pins.
DGND	E5, E6, E7, E8, E9, E10, F5, F6, F7, F8, F9, F10, G5, G6, G7, G8, G9, G10, H5, H6, H7, H8, H9, H10, J5, J6, J7, J8, J9, J10, K5, K6, K7, K8, K9, K10	P	<b>Digital Ground:</b> Used as digital ground pins.



## 4 PIN ASSIGNMENTS

### 4.1 PIN LIST of 196-PIN LPGA

PIN	NAME	PIN	NAME	PIN	NAME	PIN	NAME
A1	GPIO[1]	D8	AVDD	H1	REXT[2]	L8	AVDD
A2	GPIO[0]	D9	VDDC	H2	REXT_GND[2]	L9	VDDC
A3	NC	D10	VDDC	H3	NC	L10	VDDC
A4	NC	D11	VDDR	H4	AVDD	L11	VDDR
A5	NC	D12	NC	H5	DGND	L12	EECK
A6	NC	D13	REFCLKOP[1]	H6	DGND	L13	REFCLKOP[7]
A7	REXT[1]	D14	REFCLKON[1]	H7	DGND	L14	REFCLKON[7]
A8	REFCLKN[1]	E1	PERP[9]	H8	DGND	M1	NC
A9	PETP[5]	E2	PERN[9]	H9	DGND	M2	NC
A10	PERP[5]	E3	AGND	H10	DGND	M3	DBO[2]
A11	PETP[4]	E4	VDDC	H11	VDDC	M4	DBO[3]
A12	PERP[4]	E5	DGND	H12	CVDDR	M5	AGND
A13	SHCL I2C	E6	DGND	H13	REFCLKOP[4]	M6	AGND
A14	SHDA I2C	E7	DGND	H14	REFCLKON[4]	M7	AVDDH
B1	GPIO[3]	E8	DGND	J1	NC	M8	NC
B2	GPIO[2]	E9	DGND	J2	NC	M9	AGND
B3	NC	E10	DGND	J3	AGND	M10	AGND
B4	NC	E11	VDDC	J4	VDDC	M11	EEDI
B5	NC	E12	IREF	J5	DGND	M12	EECS L
B6	NC	E13	REFCLKOP[2]	J6	DGND	M13	PERST L
B7	REXT_GND[1]	E14	REFCLKON[2]	J7	DGND	M14	NC
B8	REFCLKP[1]	F1	PETP[9]	J8	DGND	N1	DBO[4]
B9	PETN[5]	F2	PETN[9]	J9	DGND	N2	NC
B10	PERN[5]	F3	AGND	J10	DGND	N3	PERN[0]
B11	PETN[4]	F4	VDDC	J11	SCL I2C	N4	PETN[0]
B12	PERN[4]	F5	DGND	J12	SWG LVL	N5	PERN[1]
B13	SHPCINT L	F6	DGND	J13	REFCLKOP[5]	N6	PETN[1]
B14	CLKREQ L[3]	F7	DGND	J14	REFCLKON[5]	N7	REFCLKP[0]
C1	PERP[8]	F8	DGND	K1	NC	N8	REXT_GND[0]
C2	PERN[8]	F9	DGND	K2	NC	N9	PETN[2]
C3	GPIO[6]	F10	DGND	K3	PL 512B/DBO[0]	N10	PERN[2]
C4	GPIO[5]	F11	VDDC	K4	VDDC	N11	PETN[3]
C5	GPIO[4]	F12	CVDDR	K5	DGND	N12	PERN[3]
C6	AGND	F13	REFCLKOP[3]	K6	DGND	N13	NC
C7	NC	F14	REFCLKON[3]	K7	DGND	N14	NC
C8	AVDDH	G1	REFCLKN[2]	K8	DGND	P1	NC
C9	AGND	G2	REFCLKP[2]	K9	DGND	P2	CLKBUF_PD
C10	AGND	G3	AVDDH	K10	DGND	P3	PERP[0]
C11	NC	G4	AVDD	K11	SDA I2C	P4	PETP[0]
C12	NC	G5	DGND	K12	EEDO	P5	PERP[1]
C13	CLKREQ L[2]	G6	DGND	K13	REFCLKOP[6]	P6	PETP[1]
C14	CLKREQ L[1]	G7	DGND	K14	REFCLKON[6]	P7	REFCLKN[0]
D1	PETP[8]	G8	DGND	L1	NC	P8	REXT[0]
D2	PETN[8]	G9	DGND	L2	NC	P9	PETP[2]
D3	GPIO[7]	G10	DGND	L3	DBO[1]	P10	PERP[2]
D4	VDDR	G11	VDDC	L4	VDDR	P11	PETP[3]
D5	VDDC	G12	CVDDR	L5	VDDC	P12	PERP[3]
D6	VDDC	G13	REFCLKIP	L6	VDDC	P13	DWNRST L[2]
D7	AVDD	G14	REFCLKIN	L7	AVDD	P14	DWNRST L[1]

**4.2 PIN MAP of 196-PIN LPGA**

	1	2	3	4	5	6	7	8	9	10	11	12	13	14	
A	GPIO [1]	GPIO [0]	NC	NC	NC	NC	REXT [1]	REFC LKN [1]	PETP [5]	PERP [5]	PETP [4]	PERP [4]	SHCL _I2C	SHDA _I2C	A
B	GPIO [3]	GPIO [2]	NC	NC	NC	NC	REXT GND [1]	REFC LKP [1]	PETN [5]	PERN [5]	PETN [4]	PERN [4]	SHPC INT_L	CLKRE Q_L[3]	B
C	PERP [8]	PERN [8]	GPIO [6]	GPIO [5]	GPIO [4]	AGND	NC	AVDD H	AGND	AGND	NC	NC	CLKRE Q_L[2]	CLKRE Q_L[1]	C
D	PETP [8]	PETN [8]	GPIO [7]	VDDR	VDDC	VDDC	AVDD	AVDD	VDDC	VDDC	VDDR	NC	REFC LKOP [1]	REFC LKON [1]	D
E	PERP [9]	PERN [9]	AGND	VDDC	DGND	DGND	DGND	DGND	DGND	DGND	VDDC	IREF	REFC LKOP [2]	REFC LKON [2]	E
F	PETP [9]	PETN [9]	AGND	VDDC	DGND	DGND	DGND	DGND	DGND	DGND	VDDC	CVDD R	REFC LKOP [3]	REFC LKON [3]	F
G	REFC LKN [2]	REFC LKP [2]	AVDD H	AVDD	DGND	DGND	DGND	DGND	DGND	DGND	VDDC	CVDD R	REFC LKIP	REFC LKIN	G
H	REXT [2]	REXT GND [2]	NC	AVDD	DGND	DGND	DGND	DGND	DGND	DGND	VDDC	CVDD R	REFC LKOP [4]	REFC LKON [4]	H
J	NC	NC	AGND	VDDC	DGND	DGND	DGND	DGND	DGND	DGND	SCL_I2C	SWG_LVL	REFC LKOP [5]	REFC LKON [5]	J
K	NC	NC	PL_512B /DBO[0]	VDDC	DGND	DGND	DGND	DGND	DGND	DGND	SDA_I2C	EEDO	REFCLK OP[6]	REFCLK ON[6]	K
L	NC	NC	DBO[1]	VDDR	VDDC	VDDC	AVDD	AVDD	VDDC	VDDC	VDDR	EECK	REFCLK OP[7]	REFCLK ON[7]	L
M	NC	NC	DBO[2]	DBO[3]	AGND	AGND	AVDD H	NC	AGND	AGND	EEDI	EE CS_L	PERS T_L	NC	M
N	DBO[4]	NC	PERN [0]	PETN [0]	PERN [1]	PETN [1]	REFC LKP [0]	REXT GND [0]	PETN [2]	PERN [2]	PETN [3]	PERN [3]	NC	NC	N
P	NC	CLK BUF_PD	PERP [0]	PETP [0]	PERP [1]	PETP [1]	REFC LKN [0]	REXT [0]	PETP [2]	PERP [2]	PETP [3]	PERP [3]	DWN RST_L[2]	DWN RST_L[1]	P

**Figure 4-1 PI7C9X2G308GP Ball Assignment (Transparent Top View)**

## 5 FUNCTIONAL DESCRIPTION

Multiple virtual PCI-to-PCI Bridges (VPPB), connected by a virtual PCI bus, reside in the Switch. Each VPPB contains the complete PCIe architecture layers that consist of the physical, data link, and transaction layer. The packets entering the Switch via one of VPPBs are first converted from serial bit-stream into parallel bus signals in physical layer, stripped off the link-related header by data link layer, and then relayed up to the transaction layer to extract out the transaction header. According to the address or ID embedded in the transaction header, the entire transaction packets are forwarded to the destination VPPB for formatting as a serial-type PCIe packet through the transmit circuits in the data link layer and physical layer. The following sections describe these function elements for processing PCIe packets within the Switch.

### 5.1 PHYSICAL LAYER CIRCUIT

The physical layer circuit design is based on the PHY Interface for PCI Express Architecture (PIPE). It contains Physical Media Attachment (PMA) and Physical Coding Sub-layer (PCS) blocks. PMA includes Serializer/Deserializer (SERDES), PLL<sup>1</sup>, Clock Recovery module, receiver detection circuits, beacon transmitter, electrical idle detector, and input/output buffers. PCS consists of framer, 8B/10B encoder/decoder, receiver elastic buffer, and PIPE PHY control/status circuitries. To provide the flexibility for port configuration, each lane has its own control and status signals for MAC to access individually. The main functions of physical layer circuits include the conversion between serial-link and parallel bus, provision of clock source for the Switch, resolving clock difference in receiver end, and detection of physical layer errors.

In order to meet the needs of different application, the drive amplitude, de-emphasis and equalization of each transmitting channels can be adjusted using EEPROM, SMBus or I2C individually. De-emphasis of -3.5 db is implemented by the transmitters when full swing signaling is used, while an offset can be individually applied to each channel.

#### 5.1.1 RECEIVER DETECTION

The physical layer circuits implement receiver detection, which detects the presence of an attached 50 ohm to ground termination as per PCI Express Specification. The detect circuits determine if the voltage levels of the receiver have crossed the internal threshold after a configurable time determined by the Receiver Detection Threshold field in the Physical Parameter 2 Register (offset 7Ch, bit[6:4]) as listed in Table 5-1 , which can be configured by EEPROM, SMBus or I2C settings.

**Table 5-1 Receiver Detection Threshold Settings**

Receiver Detection Threshold	Threshold
000	1.0 us
001	2.0 us
010	4.0 us (Recommended)
011	5.0 us
100	10 us
101	20 us
110	40 us
111	50 us

<sup>1</sup> Multiple lanes could share the PLL.

## 5.1.2 RECEIVER SIGNAL DETECTION

Receiver signal idling is detected with levels above a programmable threshold specified by Receiver Signal Detect field in the Physical Parameter 2 Register (Offset 7Ch, bit[21:20]) as listed in Table 5-2, which can be configured on a per-port basis via EEPROM, SMBus or I2C settings.

**Table 5-2 Receiver Signal Detect Threshold**

Receiver Signal Detect	Min (mV ppd)	Max (mV ppd)
00	50	80
01 (Recommended)	65	175
10	75	200
11	120	240

## 5.1.3 RECEIVER EQUALIZATION

The receiver implements programmable equalizer via the Receiver Equalization field in the Physical Parameter 2 Register (Offset 7Ch, bit[25:22]) as listed in Table 5-3, which can be configured on a per-port basis via EEPROM, SMBus or I2C settings.

**Table 5-3 Receiver Equalization Settings**

Receiver Equalization	Equalization
0000	Off
0010	Low
0110 (Recommended)	Medium
1110	High

## 5.1.4 TRANSMITTER SWING

The PCI Express transmitters support implementations of both full voltage swing and half (low) voltage swing. In full swing signaling mode, the transmitters implement de-emphasis, while in half swing mode, the transmitters do not. The Transmitter Swing field in the Physical Parameter 2 Register (offset 7Ch, Bit[30]) is used for the selection of full swing signaling or half swing signaling, which can be configured on a per-port basis via EEPROM, SMBus or I2C settings.

**Table 5-4 Transmitter Swing Settings**

Transmitter Swing	Mode	De-emphasis
0	Full Voltage Swing	Implemented
1	Half Voltage Swing	Not implemented

## 5.1.5 DRIVE AMPLITUDE AND DE-EMPHASIS SETTINGS

Depending on the operation condition (voltage swing and de-emphasis condition), one of the Drive Amplitude Base Level fields in the Switch Operation Mode Register (offset 74h) and one of the Drive De-Emphasis Base Level fields in the Physical Parameter 1 Register (offset 78h) are active for configuration of the amplitude and de-emphasis.

The final drive amplitude and drive de-emphasis are the summation of the base level value and the offset value. The offset value for drive amplitude is 25 mV pd, and 6.25 mV pd for drive de-emphasis.

The driver output waveform is the synthesis of amplitude and de-emphasis as shown in Figure 5-1. The driver amplitude without de-emphasis is specified as a peak differential voltage level (mVpd), and the driver de-emphasis modifies the driver amplitude.

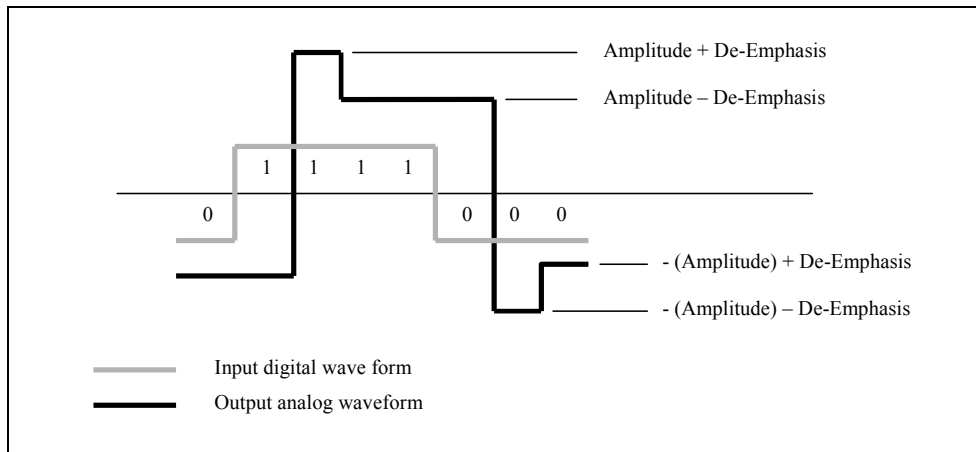

Figure 5-1 Driver Output Waveform

### 5.1.6 DRIVE AMPLITUDE

Only one of the Drive Amplitude Level field in the Switch Operation Mode Register (offset 74h, bit[20:16], bit[25:21] and bit[30:26]) listed in Table 5-5 is active depending on the de-emphasis and swing condition. The settings and the corresponding values of the amplitude level are listed in Table 5-6, which can be configured by EEPROM, SMBus or I2C settings.

Table 5-5 Drive Amplitude Base Level Registers

Active Register	De-Emphasis Condition	Swing Condition
Drive Amplitude Level (3P5 Nom)	-3.5 db	Full
Drive Amplitude Level (6P0 Nom)	-6.0 db	Full
Drive Amplitude Level (Half)	N/A	Half

Table 5-6 Drive Amplitude Base Level Settings

Setting	Amplitude (mV pd)	Setting	Amplitude (mV pd)	Setting	Amplitude (mV pd)
00000	0	00111	175	01110	350
00001	25	01000	200	01111	375
00010	50	01001	225	10000	400
00011	75	01010	250	10001	425
00100	100	01011	275	10010	450
00101	125	01100	300	10011	475
00110	150	01101	325	Others	Reserved

Note:

1. Nominal levels. Actual levels will vary with temperature, voltage and board effects.
2. The maximum nominal amplitude of the output driver is 475 mV pd. Combined values of driver amplitude and de-emphasis greater than 475 mV pd should be avoided.
3. At higher amplitudes, actual swings will be less than the theoretical value due to process variations and environment factors, such as voltage overhead compression, package losses, board losses, and other effects.

### 5.1.7 DRIVE DE-EMPHASIS

The Drive De-Emphasis Level field in the Physical Parameter 1 Register (Offset 78h, bit[20:16]) listed in Table 5-7 controls the de-emphasis base level. The settings and the corresponding values of the de-emphasis level are listed in Table 5-8, which can be configured by EEPROM, SMBus or I2C settings.

**Table 5-7 Drive De-Emphasis Base Level Register**

Register	De-Emphasis Condition
C EMP POST GEN1 3P5 NOM	-3.5 db
C EMP POST GEN2 3P5 NOM	-3.5 db
C EMP POST GEN2 6P0 NOM	-6.0 db

**Table 5-8 Drive De-Emphasis Base Level Settings**

Setting	De-Emphasis (mV pd)	Setting	De-Emphasis (mV pd)	Setting	De-Emphasis (mV pd)
00000	0.0	01011	69.0	10110	137.5
00001	6.0	01100	75.0	10111	144.0
00010	12.5	01101	81.0	11000	150.0
00011	19.0	01110	87.0	11001	156.0
00100	25.0	01111	94.0	11010	162.5
00101	31.0	10000	100.0	11011	169.0
00110	37.5	10001	106.0	11100	175.0
00111	44.0	10010	112.5	11101	181.0
01000	50.0	10011	119.0	11110	187.5
01001	56.0	10100	125.0	11111	194.0
01010	62.5	10101	131.0	-	-

Note:

1. Nominal levels. Actual levels will vary with temperature, voltage and board effects.
2. The maximum nominal amplitude of the output driver is 475 mV pd. Combined values of driver amplitude and de-emphasis greater than 475 mV pd should be avoided.
3. At higher amplitudes, actual swings will be less than the theoretical value due to process variations and environment factors, such as voltage overhead compression, package losses, board losses, and other effects.

### 5.1.8 TRANSMITTER ELECTRICAL IDLE LATENCY

After the last character of the PCI Express transmission, the output current is reduced, and a differential voltage of less than 20 mV with common mode of VTX-CM-DC is established within 20 UI. This delay time is programmable via Transmitter PHY Latency field in the Physical Parameter 2 Register (Offset 7Ch, bit[3:0]), which can be configured by EEPROM, SMBus or I2C settings.

## 5.2 DATA LINK LAYER (DLL)

The Data Link Layer (DLL) provides a reliable data transmission between two PCI Express points. An ACK/NACK protocol is employed to guarantee the integrity of the packets delivered. Each Transaction Layer Packet (TLP) is protected by a 32-bit LCRC for error detection. The DLL receiver performs LCRC calculation to determine if the incoming packet is corrupted in the serial link. If an LCRC error is found, the DLL transmitter would issue a NACK data link layer packet (DLLP) to the opposite end to request a re-transmission, otherwise an ACK DLLP would be sent out to acknowledge on reception of a good TLP.

In the transmitter, a retry buffer is implemented to store the transmitted TLPs whose corresponding ACK/NACK DLLP have not been received yet. When an ACK is received, the TLPs with sequence number equals to and smaller than that carried in the ACK would be flushed out from the buffer. If a NACK is received or no ACK/NACK is returned from the link partner after the replay timer expires, then a replay mechanism built in DLL transmitter is

triggered to re-transmit the corresponding packet that receives NACK or time-out and any other TLP transmitted after that packet.

Meanwhile, the DLL is also responsible for the initialization, updating, and monitoring of the flow-control credit. All of the flow control information is carried by DLLP to the other end of the link. Unlike TLP, DLLP is guarded by 16-bit CRC to detect if data corruption occurs.

In addition, the Media Access Control (MAC) block, which is consisted of LTSSM, multiple lanes de-skew, scrambler/de-scrambler, clock correction from inserting skip order-set, and PIPE-related control/status circuits, is implemented to interface physical layer with data link layer.

### **5.3 TRANSACTION LAYER RECEIVE BLOCK (TLP DECAPSULATION)**

The receiving end of the transaction layer performs header information retrieval and TC/VC mapping (see section 5.5), and it validates the correctness of the transaction type and format. If the TLP is found to contain an illegal header or the indicated packet length mismatches with the actual packet length, then a Malformed TLP is reported as an error associated with the receiving port. To ensure end-to-end data integrity, a 32-bit ECRC is checked against the TLP at the receiver if the digest bit is set in header.

### **5.4 ROUTING**

The transaction layer implements three types of routing protocols: ID-based, address-based, and implicit routing. For configuration reads, configuration writes, transaction completion, and user-defined messages, the packets are routed by their destination ID constituted of bus number, device number, and function number. Address routing is employed to forward I/O or memory transactions to the destination port, which is located within the address range indicated by the address field carried in the packet header. The packet header indicates the packet types including memory read, memory write, IO read, IO write, Message Signaling Interrupt (MSI) and user-defined message. Implicit routing is mainly used to forward system message transactions such as virtual interrupt line, power management, and so on. The message type embedded in the packet header determines the routing mechanism.

If the incoming packet cannot be forwarded to any other port due to a miss to hit the defined address range or targeted ID, this is considered as Unsupported Request (UR) packet, which is similar to a master abort event in PCI protocol.

### **5.5 TC/VC MAPPING**

The 3-bit TC field defined in the header identifies the traffic class of the incoming packets. To enable the differential service, a TC/VC mapping table at destination port that is pre-programmed by system software or EEPROM pre-load is utilized to cast the TC labeled packets into the desired virtual channel. Note that TC0 traffic is mapped into VC0 channel by default. After the TC/VC mapping, the receive block dispatches the incoming request, completion, or data into the appropriate VC0 and VC1 queues.

### **5.6 QUEUE**

In PCI Express, it defines six different packet types to represent request, completion, and data. They are respectively Posted Request Header (PH), Posted Request Data payload (PD), Non-Posted Request Header (NPH), Non-Posted Data Payload (NPD), Completion Header (CPLH) and Completion Data payload (CPLD). Each packet with different type would be put into a separate queue in order to facilitate the following ordering processor. Since NPD usually contains one DW, it can be merged with the corresponding NPH into a common queue named NPHD.

Except NPHD, each virtual channel (VC0 or VC1) has its own corresponding packet header and data queue. When only VC0 is needed in some applications, VC1 can be disabled and its resources assigned to VC0 by asserting VC1\_EN (Virtual Channel 1 Enable) to low.

### 5.6.1 PH

PH queue provides TLP header spaces for posted memory writes and various message request headers. Each header space occupies sixteen bytes to accommodate 3 DW or 4 DW headers. There are two PH queues for VC0 and VC1 respectively.

### 5.6.2 PD

PD queue is used for storing posted request data. If the received TLP is of the posted request type and is determined to have payload coming with the header, the payload data would be put into PD queue. There are two PD queues for VC0 and VC1 respectively.

### 5.6.3 NPHD

NPHD queue provides TLP header spaces for non-posted request packets, which include memory read, IO read, IO write, configuration read, and configuration write. Each header space takes twenty bytes to accommodate a 3-DW header, a 4-DW header, a 3-DW header with 1-DW data, and a 4-DW header with 1-DW data. There is only one NPHD queue for VC0, since non-posted request cannot be mapped into VC1.

### 5.6.4 CPLH

CPLH queue provides TLP header space for completion packets. Each header space takes twelve bytes to accommodate a 3-DW header. Please note that there are no 4-DW completion headers. There are two CPLH queues for VC0 and VC1 respectively.

### 5.6.5 CPLD

CPLD queue is used for storing completion data. If the received TLP is of the completion type and is determined to have payload coming with the header, the payload data would be put into CPLD queue. There are two CPLD queues for VC0 and VC1 respectively.

## 5.7 TRANSACTION ORDERING

Within a VPPB, a set of ordering rules is defined to regulate the transactions on the PCI Express Switch including Memory, IO, Configuration and Messages, in order to avoid deadlocks and to support the Producer-Consumer model. The ordering rules defined in table 5-9 apply within a single Traffic Class (TC). There is no ordering requirement among transactions within different TC labels. Since the transactions with the same TC label are not allowed to map into different virtual channels, it implies no ordering relationship between the traffic in VC0 and VC1.



**Table 5-9 Summary of PCI Express Ordering Rules**

Row Pass Column	Posted Request	Read Request	Non-posted Write Request	Read Completion	Non-posted Write Completion
Posted Request	Yes/No <sup>1</sup>	Yes <sup>3</sup>	Yes <sup>3</sup>	Yes <sup>3</sup>	Yes <sup>3</sup>
Read Request	No <sup>2</sup>	Yes	Yes	Yes	Yes
Non-posted Write Request	No <sup>2</sup>	Yes	Yes	Yes	Yes
Read Completion	Yes/No <sup>3</sup>	Yes	Yes	Yes	Yes
Non-Posted Write Completion	Yes <sup>4</sup>	Yes	Yes	Yes	Yes

1. When the Relaxed Ordering Attribute bit is cleared, the Posted Request transactions including memory write and message request must complete on the egress bus of VPPB in the order in which they are received on the ingress bus of VPPB. If the Relaxed Ordering Attribute bit is set, the Posted Request is permitted to pass over other Posted Requests occurring before it.
2. A Read Request transmitting in the same direction as a previously queued Posted Request transaction must push the posted write data ahead of it. The Posted Request transaction must complete on the egress bus before the Read Request can be attempted on the egress bus. The Read transaction can go to the same location as the Posted data. Therefore, if the Read transaction were to pass the Posted transaction, it would return stale data.
3. When the Relaxed Ordering Attribute bit is cleared, a Read completion must “pull” ahead of previously queued posted data transmitting in the same direction. In this case, the read data transmits in the same direction as the posted data, and the requestor of the read transaction is on the same side of the VPPB as the completer of the posted transaction. The posted transaction must deliver to the completer before the read data is returned to the requestor. If the Relaxed Ordering Attribute bit is set, then a read completion is permitted to pass a previously queued Memory Write or Message Request.
4. Non-Posted Write Completions are permitted to pass a previous Memory Write or Message Request transaction. Such transactions are actually transmitting in the opposite directions and hence have no ordering relationship.
5. Posted Request transactions must be given opportunities to pass Non-posted Read and Write Requests as well as Completions. Otherwise, deadlocks may occur when some older bridges, which do not support delayed transactions are mixed with PCIe Switch in the same system. A fairness algorithm is used to arbitrate between the Posted Write queue and the Non-posted transaction queue

## 5.8 PORT ARBITRATION

Among multiple ingress ports, the port arbitration built in the egress port determines which incoming packets to be forwarded to the output port. The arbitration algorithm contains hardware fixed Round Robin, 128-phase Weighted Round-Robin and programmable 128-phase time-based WRR. The port arbitration is held within the same VC channel. It means that each port has two port arbitration circuitries for VC0 and VC1 respectively. At the upstream ports, in addition to the inter-port packets, the intra-port packet such as configurations completion would also join the arbitration loop to get the service from Virtual Channel 0.

## 5.9 VC ARBITRATION

After port arbitration, VC arbitration is executed among different VC channels within the same source. Three arbitration algorithms are provided to choose the appropriate VC: Strict Priority, Round Robin or Weighted Round Robin.

## **5.10 FLOW CONTROL**

PCI Express employs Credit-Based Flow Control mechanism to make buffer utilization more efficient. The transaction layer transmitter ensures that it does not transmit a TLP to an opposite receiver unless the receiver has enough buffer space to accept the TLP. The transaction layer receiver has the responsibility to advertise the free buffer space to an opposite transmitter to avoid packet stale. In this Switch, each port has its own separate queues for different traffic types and the credits are sent to data link layer on the fly. The data link layer compares the current available credits with the monitored ones and reports the updated credit to the counterpart. If no new credit is acquired, the credit reported is scheduled for every 30 us to prevent the link from entering retrain. On the other hand, the receiver at each egress port gets the usable credits from the opposite end in a link. The output port broadcasts them to all the other ingress ports to get packet transmission.

## **5.11 TRANSACTION LAYER TRANSMIT BLOCK (TLP ENCAPSULATION)**

The transmit portion of transaction layer performs the following functions. They construct the all types of forwarded TLP generated from VC arbiter, respond with the completion packets when the local resource (i.e. configuration register) is accessed, and regenerate the message that terminates at receiver to RC if acting as an upstream port.

## 6 EEPROM INTERFACE AND SYSTEM MANAGEMENT/I2C BUS

The EEPROM interface consists of four pins: EECK (EEPROM clock), EEDI (EEPROM serial data input), EEDO (EEPROM serial data output) and EECS (EEPROM chip select). The Switch may control a Microchip 25LC128 or compatible SPI EEPROM parts. The EEPROM is used to initialize a number of registers before enumeration. This is accomplished after PERST\_L is de-asserted, at which time the data from the EEPROM is loaded. The EEPROM interface is organized into a 16-bit base, and the Switch supplies an 8-bit EEPROM word address.

### 6.1 EEPROM INTERFACE

#### 6.1.1 AUTO MODE EEPROM ACCESS

The Switch may access the EEPROM in a WORD format by utilizing the auto mode through a hardware sequencer. The EEPROM start-control, address, and read/write commands can be accessed through the configuration register. Before each access, the software should check the Autoload Status bit before issuing the next start.

#### 6.1.2 EEPROM MODE AT RESET

During a reset, the Switch will automatically load the information/data from the EEPROM if the automatic load condition is met. The first offset in the EEPROM contains a signature. If the signature is recognized, the autoload initiates right after the reset.

During the autoload, the Bridge will read sequential words from the EEPROM and write to the appropriate registers. Before the Bridge registers can be accessed through the host, the autoload condition should be verified by reading bit [4] offset A0h (EEPROM Autoload Status). The host access is allowed only after the status of this bit is set to '1' which indicates that the autoload initialization sequence is complete.

#### 6.1.3 EEPROM SPACE ADDRESS MAP

15 – 8	7 – 0	BYTE OFFSET
EEPROM Signature (1516h)		00h
Vendor ID		02h
Device ID		04h
Miscellaneous Parameter 0 for Port 0~2		06h
Subsystem Vendor ID		08h
Subsystem ID		0Ah
Miscellaneous Parameter 1 for Port 0~2		0Ch
PHY TX Margin Parameter for Port 0~2		0Eh
PHY Parameter 0 for Port 0~2		10h
PHY Parameter 1 for Port 0~2		12h
PHY parameter 2/3 for Port 0~2		14h
XPIP_CSR4[15:0] for Port 0~2		16h
XPIP_CSR4[31:16] for Port 0~2		18h
XPIP_CSR5[15:0] for Port 0~2		1Ah
BUFFER_CTRL[7:0] for Port 0~2	XPIP_CSR5[23:16] for Port 0~2	1Ch
MAC_CTR/PHY Parameter 3 for Port 0~2		1Eh
XPIP_CSR2[14:12][10:0]/Deskew mode select for Port 0		20h
XPIP_CSR2[14:12][10:0]/Deskew mode select for Port 1		22h
XPIP_CSR2[14:12][10:0]/Deskew mode select for Port 2		24h
Reserved		26h~2Eh
PHY Parameter2[30:16] for Port 0		30h
PHY Parameter2[30:16] for Port 1		32h

15 – 8	7 – 0	BYTE OFFSET
PHY Parameter2[30:16] for Port 2		34h
Reserved		36h~3Eh
PHY Parameter 2[12:8]/PHY Parameter 3[6:0]/Selectable De-emphasis/XPIP_CSR2[11]/TL_CSR[9:8] for Port 0		40h
T PHY Parameter 2[12:8]/PHY Parameter 3[6:0]/Selectable De-emphasis/XPIP_CSR2[11]/TL_CSR[9:8] for Port 1		42h
PHY Parameter 2[12:8]/PHY Parameter 3[6:0]/Selectable De-emphasis/XPIP_CSR2[11]/TL_CSR[9:8] for Port 2		44h
Reserved		46h~4Eh
PM Data for Port 0	PM Capability for Port 0	50h
PM Data for Port 1	PM Capability for Port 1	52h
PM Data for Port 2	PM Capability for Port 2	54h
Reserved		56h~5Eh
TC/VC Map for Port 0 (VC0)	Slot Clock/LPVC Count/Port Num for Port 0	60h
TC/VC Map for Port 1 (VC0)	Slot Implemented/Slot Clock/LPVC Count/Port Num for Port 1	62h
TC/VC Map for Port 2 (VC0)	Slot Implemented/Slot Clock/LPVC Count/Port Num for Port 2	64h
Reserved		66h~6Eh
Power Budgeting Capability Register for Port 0		70h
Power Budgeting Capability Register for Port 1		72h
Power Budgeting Capability Register for Port 2		74h
Reserved		76h~7Eh
XPIP_CSR5[31:24] for Port 0	PM Control Para/Rx Polarity/VGA Decode for Port 0	80h
XPIP_CSR5[31:24] for Port 1	PM Control Para/Rx Polarity/VGA Decode for Port 1	82h
XPIP_CSR5[31:24] for Port 2	PM Control Para/Rx Polarity/VGA Decode for Port 2	84h
Reserved		86h~90h
Slot Capability 0 for Port 1		92h
Slot Capability 0 for Port 2		94h
Reserved		96h~A0h
Slot Capability 1 for Port 1		A2h
Slot Capability 1 for Port 2		A4h
Reserved		A6h~AEh
XPIP_CSR3[15:0] for Port 0		B0h
XPIP_CSR3[15:0] for Port 1		B2h
XPIP_CSR3[15:0] for Port 2		B4h
Reserved		B6h~BEh
XPIP_CSR3[31:16] for Port 0		C0h
XPIP_CSR3[31:16] for Port 1		C2h
XPIP_CSR3[31:16] for Port 2		C4h
Reserved		C6h~CEh
REV_TS_CTR/Replay Time-out Counter for Port 0		D0h
REV_TS_CTR/Replay Time-out Counter for Port 1		D2h
REV_TS_CTR/Replay Time-out Counter for Port 2		D4h
Reserved		D6h~DEh
Acknowledge Latency Timer for Port 0		E0h
Acknowledge Latency Timer for Port 1		E2h
Acknowledge Latency Timer for Port 2		E4h
Reserved		E6h~EEh
XPIP_CSR6[23:16][11:10]/Device Specific PM Cap for Port 0		F0h
XPIP_CSR6[23:16][11:10]/Device Specific PM Cap for Port 1		F2h
XPIP_CSR6[23:16][11:10]/Device Specific PM Cap for Port 2		F4h
Reserved		F6h~FEh
TC/VC Map for Port 0 (VC1)	VC1 MAX Time Slot for Port 0	100h
TC/VC Map for Port 1 (VC1)	VC1 MAX Time Slot for Port 1	102h
TC/VC Map for Port 2 (VC1)	VC1 MAX Time Slot for Port 2	104h
Reserved		106h~10Eh
LTSSM_CSR for Port 0	Reserved	110h
LTSSM_CSR for Port 1	L1PM for Port 1	112h
LTSSM_CSR for Port 2	L1PM for Port 2	114h
Reserved		116h~11Eh
Hotplug_CSR for Port 0		120h

15 – 8	7 – 0	BYTE OFFSET
	Hotplug_CSR for Port 1	122h
	Hotplug_CSR for Port 2	124h
	Reserved	126h~12Eh
	MAC_CSR1 for Port 0	130h
	MAC_CSR1 for Port 1	132h
	MAC_CSR1 for Port 2	134h
	Reserved	136h~13Eh
	CPLD Flow Control Enable	140h
	X1 CPLD Flow Control Threshold	142h
	X2 CPLD Flow Control Threshold	144h
	X4 CPLD Flow Control Threshold	146h
	Reserved	148h~14Eh
	Power Saving Disable for Port 0	150h
	Power Saving Disable for Port 1	152h
	Power Saving Disable for Port 2	154h
	Reserved	156h~15Eh

### 6.1.4 MAPPING EEPROM CONTENTS TO CONFIGURATION REGISTERS

ADDRESS	PCI CFG OFFSET	DESCRIPTION
00h		<b>EEPROM signature</b> – 1516h
02h	<b>00h ~ 01h</b>	<b>Vendor ID</b>
04h	<b>02h ~ 03h</b>	<b>Device ID</b>
06h	<b>144h (Port 0~2)</b> 144h: Bit [0]  <b>CCh (Port 0~2)</b> CCh: Bit [14:12] CCh: Bit [17:15] CCh: Bit[18]  <b>74h (Port 0)</b> 74h: Bit [5] 74h: Bit [6] 74h: Bit [0] 74h: Bit [2:1] 74h: Bit [3] 74h: Bit [4] 74h: Bit [7]	<b>Extended VC Count for Port 0~2</b> <ul style="list-style-type: none"> <li>Bit [0]: it represents the supported VC count other than the default VC</li> </ul> <b>Link Capability for Port 0~2</b> <ul style="list-style-type: none"> <li>Bit [3:1]: it represents L0s Exit Latency for all ports</li> <li>Bit [6:4]: it represents L1 Exit Latency for all ports</li> <li>Bit [7]: clock pm capability for all ports</li> </ul> <b>Switch Mode Operation for Port 0</b> <ul style="list-style-type: none"> <li>Bit [8]: no ordering on packets for different egress port mode</li> <li>Bit [9]: no ordering on different tag of completion mode</li> <li>Bit [10]: store and forward</li> <li>Bit [12:11]: cut-through threshold</li> <li>Bit [13]: port arbitrator mode</li> <li>Bit [14]: credit Update mode</li> <li>Bit [15]: non-post store and forward only mode</li> </ul>
08h	<b>B4h ~ B5h</b>	<b>Subsystem Vendor ID</b>
0Ah	<b>B6h ~ B7h</b>	<b>Subsystem ID</b>
0Ch	<b>C4h (Port 0~2)</b> C4h: Bit [1:0]  <b>CCh (Port 0~2)</b> CCh: Bit[11:10]  <b>C4h (Port 0~2)</b> C4h: Bit[15]  <b>70h (Port 0~2)</b> 70h: Bit [14]  <b>74h (Port 0~2)</b> 74h: Bit [15]  <b>70h (Port 0~2)</b> 70h: Bit [13]  <b>8Ch (Port 0~2)</b> 8Ch: Bit[5]	<b>Max_Payload_Size Support for Port 0~2</b> <ul style="list-style-type: none"> <li>Bit [1:0]: indicate the maximum payload size that the device can support for the TLP</li> </ul> <b>ASPM Support for Port 0~2</b> <ul style="list-style-type: none"> <li>Bit [3:2]: indicate the level of ASPM supported on the PCIe link</li> </ul> <b>Role_Base Error Reporting for Port 0~2</b> <ul style="list-style-type: none"> <li>Bit [4]: indicate implement the role-base error reporting</li> </ul> <b>MSI Capability Disable for Port 0~2</b> <ul style="list-style-type: none"> <li>Bit [5]: disable MSI capability</li> </ul> <b>Compliance Pattern Parity Control Disable for Port 0~2</b> <ul style="list-style-type: none"> <li>Bit [6]: disable compliance pattern parity</li> </ul> <b>Power Management Capability Disable for Port 0~2</b> <ul style="list-style-type: none"> <li>Bit [7]: disable power management capability</li> </ul> <b>ORDER RULE5 Enable for port 0~2</b> Bit[8]: capability for post packet pass non-post packet

ADDRESS	PCI CFG OFFSET	DESCRIPTION
	<b>CCh (Port 1~2)</b> CCh: Bit [21]  <b>8Ch (Port 0~2)</b> 8Ch: Bit [6]  <b>8Ch (Port 0~2)</b> 8Ch: Bit[0]  <b>CCh (Port 0~2)</b> CCh: Bit [19]  <b>8Ch (Port 0~2)</b> 8Ch: Bit[1]  <b>E4h (Port 0~2)</b> E4h: Bit[12]  <b>8Ch (Port 0~2)</b> 8Ch: Bit[3]	<b>Link Bandwidth Notification Capability for port 1~2</b> Bit [9]: link bandwidth notification capability  <b>Ordering Frozen for Port 0~2</b> <ul style="list-style-type: none"> <li>Bit [10]: freeze the ordering feature</li> </ul> <b>TX SOF Latency Mode for Port 0~2</b> <ul style="list-style-type: none"> <li>Bit [11]: set to zero to shorten latency</li> </ul> <b>Surprise Down Capability Enable for Port 0~2</b> <ul style="list-style-type: none"> <li>Bit [12]: enable surprise down capability</li> </ul> <b>Power Management's Data Select Register R/W Capability for Port 0~2</b> <ul style="list-style-type: none"> <li>Bit [13]: enable Data Select Register R/W</li> </ul> <b>Flow Control Update Type LTR Capability Enable for Port 0~2</b> <ul style="list-style-type: none"> <li>Bit [14]: LTR capability enable</li> </ul> <b>4KB Boundary Check Enable for Port 0~2</b> <ul style="list-style-type: none"> <li>Bit [15]: enable 4KB boundary check</li> </ul>
0Eh	<b>94h (Port 0~2)</b> 94h: Bit[4:0] 94h: Bit[9:5] 94h: Bit[14:10]  <b>E4h (Port 0~2)</b> E4h: Bit [18]	<b>PHY TX Margin Parameter for Port 0~2</b> <ul style="list-style-type: none"> <li>Bit[4:0]: C_DRV_LVL_3P5_MGN2</li> <li>Bit[9:5]: C_DRV_LVL_6P0_MGN2</li> <li>Bit[14:10]: C_DRV_LVL_HALF_MGN2</li> </ul> <b>OBFF Capability Enable for Port 0~2</b> <ul style="list-style-type: none"> <li>Bit [15]: enable OBFF capability</li> </ul>
10h	<b>74h (Port 0~2)</b> 74h: Bit[20:16] 74h: Bit[25:21] 74h: Bit[30:26]  <b>8Ch (Port0~2)</b> 8Ch: Bit[31]	<b>PHY Parameter 0 for Port 0~2</b> <ul style="list-style-type: none"> <li>Bit [4:0]: C_DRV_LVL_3P5_NOM</li> <li>Bit [9:5]: C_DRV_LVL_6P0_NOM</li> <li>Bit [14:10]: C_DRV_LVL_HALF_NOM</li> </ul> <b>TL_CSR[31] for Port 0~2</b> <ul style="list-style-type: none"> <li>Bit [15]: P35_GEN2_MODE</li> </ul>
12h	<b>78h (Port 0~2)</b> 78h: Bit[20:16] 78h: Bit[25:21] 78h: Bit[30:26]  <b>3Ch (Port 1~2)</b> 3Ch: Bit [8]	<b>PHY Parameter 1 for Port 0~2</b> <ul style="list-style-type: none"> <li>Bit [4:0]: C_EMP_POST_GEN1_3P5_NOM</li> <li>Bit [9:5]: C_EMP_POST_GEN2_3P5_NOM</li> <li>Bit [14:10]: C_EMP_POST_GEN2_6P0_NOM</li> </ul> <b>Interrupt pin for Port 1~2</b> <ul style="list-style-type: none"> <li>Bit [15]: set when INTA is requested for interrupt resource</li> </ul>
14h	<b>7Ch (Port 0~2)</b> 7Ch: Bit[3:0] 7Ch: Bit[6:4]  <b>90h (Port 0~2)</b> 90h: Bit[19:15]  <b>8Ch (Port 0~2)</b> 8Ch: Bit[2] 8Ch: Bit[7] 8Ch: Bit[12]	<b>PHY Parameter 2 for Port 0~2</b> <ul style="list-style-type: none"> <li>Bit [3:0]: C_TX_PHY_LATENCY</li> <li>Bit [6:4]: C_REC_DETECT_USEC</li> </ul> <b>PHY Parameter 3 for Port 0~2</b> <ul style="list-style-type: none"> <li>Bit [11:7]: C_EMP_POST_HALF_DELTA</li> </ul> <b>TL_CSR[2][7] for Port 0~2</b> <ul style="list-style-type: none"> <li>Bit [12]: request abort select</li> <li>Bit [13]: grant fail to idle in port arbiter</li> <li>Bit [14]: ARB_VCFLG_SEL</li> </ul>
16h	<b>84h (Port 0~2)</b> 84h: Bit[15:0]	<b>XPIP_CSR4[15:0] for Port 0~2</b> <ul style="list-style-type: none"> <li>Bit[15:0]: XPIP_CSR4[15:0]</li> </ul>
18h	<b>84h (Port 0~2)</b> 84h: Bit[31:16]	<b>XPIP_CSR4[31:16] for Port 0~2</b> <ul style="list-style-type: none"> <li>Bit[15:0]: XPIP_CSR4[31:16]</li> </ul>
1Ah	<b>88h (Port 0~2)</b> 88h: Bit[15:0]	<b>XPIP_CSR5[15:0] for Port 0~2</b> <ul style="list-style-type: none"> <li>Bit[15:0]: XPIP_CSR5[15:0]</li> </ul>
1Ch	<b>88h (Port 0~2)</b> 88h: Bit[23:16]  <b>98h (Port 0~3)</b> 98h: Bit[23:16]	<b>XPIP_CSR5[23:16] for Port 0~2</b> <ul style="list-style-type: none"> <li>Bit[7:0]: XPIP_CSR5[23:16]</li> </ul> <b>BUFFER_CTRL[7:0] for Port 0~2</b> <ul style="list-style-type: none"> <li>Bit[15:8]: reference clock Buffer control</li> </ul>
1Eh	<b>90h (Port 0~2)</b> 90h: Bit[21:20] 90h: Bit[23:22] 90h: Bit[25:24]	<b>PHY Parameter 3 for Port 0~2</b> <ul style="list-style-type: none"> <li>Bit [1:0]: C_DRV_LVL_3P5_DELTA</li> <li>Bit [3:2]: C_DRV_LVL_6P0_DELTA</li> <li>Bit [5:4]: C_DRV_LVL_HALF_DELTA</li> </ul>

ADDRESS	PCI CFG OFFSET	DESCRIPTION
	90h: Bit[27:26] 90h: Bit[29:28] 90h: Bit[31:30]  <b>8Ch (Port 0~2)</b> 8Ch: Bit[29:26]	<ul style="list-style-type: none"> <li>▪ Bit [7:6]: C_EMP_POST_GEN1_3P5_DELTA</li> <li>▪ Bit [9:8]: C_EMP_POST_GEN2_3P5_DELTA</li> <li>▪ Bit [11:10]: C_EMP_POST_GEN2_6P0_DELTA</li> </ul> <p><b>MAC Control Parameter for Port 0~2</b></p> <ul style="list-style-type: none"> <li>▪ Bit[15:12]: MAC_CTR</li> </ul>
20h	<b>78h (Port 0)</b> 78h: Bit[7:0]  <b>68h (Port 0)</b> 68h: Bit [14:13]  <b>78h (Port 0)</b> 78h: Bit[9:8] 78h: Bit[10] 78h: Bit[13:12] 78h: Bit[14]	<p><b>FTS Number for Port 0</b></p> <ul style="list-style-type: none"> <li>▪ Bit [7:0]: FTS number at receiver side</li> </ul> <p><b>Deskew Mode Select for Port 0</b></p> <ul style="list-style-type: none"> <li>▪ Bit [9:8]:deskew mode select</li> </ul> <p><b>XPIP_CSR2[14:8] for Port 0</b></p> <ul style="list-style-type: none"> <li>▪ Bit [11:10]: scrambler control</li> <li>▪ Bit [12]: L0s</li> <li>▪ Bit[14:13]: change speed select</li> <li>▪ Bit[15]: change speed enable</li> </ul>
22h	<b>78h (Port 1)</b> 78h: Bit[7:0]  <b>68h (Port 1)</b> 68h: Bit [14:13]  <b>78h (Port 1)</b> 78h: Bit[9:8] 78h: Bit[10] 78h: Bit[13:12] 78h: Bit[14]	<p><b>FTS Number for Port 1</b></p> <ul style="list-style-type: none"> <li>▪ Bit [7:0]: FTS number at receiver side</li> </ul> <p><b>Deskew Mode Select for Port 1</b></p> <ul style="list-style-type: none"> <li>▪ Bit [9:8]: deskew mode select</li> </ul> <p><b>XPIP_CSR2[14:8] for Port 1</b></p> <ul style="list-style-type: none"> <li>▪ Bit [11:10]: scrambler control</li> <li>▪ Bit [12]: L0s</li> <li>▪ Bit[14:13]: change speed select</li> <li>▪ Bit[15]: change speed enable</li> </ul>
24h	<b>78h (Port 2)</b> 78h: Bit[7:0]  <b>68h (Port 2)</b> 68h: Bit [14:13]  <b>78h (Port 2)</b> 78h: Bit[9:8] 78h: Bit[10] 78h: Bit[13:12] 78h: Bit[14]	<p><b>FTS Number for Port 2</b></p> <ul style="list-style-type: none"> <li>▪ Bit [7:0]: FTS number at receiver side</li> </ul> <p><b>Deskew Mode Select for Port 2</b></p> <ul style="list-style-type: none"> <li>▪ Bit [9:8]: deskew mode select</li> </ul> <p><b>XPIP_CSR2[14:8] for Port 2</b></p> <ul style="list-style-type: none"> <li>▪ Bit [11:10]: scrambler control</li> <li>▪ Bit [12]: L0s</li> <li>▪ Bit[14:13]: change speed select</li> <li>▪ Bit[15]: change speed enable</li> </ul>
30h	<b>7Ch (Port 0)</b> 7Ch: Bit[30:16]	<b>PHY Parameter 2[30:16] for Port 0</b> ▪ Bit [14:0]: PHY parameter 2
32h	<b>7Ch (Port 1)</b> 7Ch: Bit[30:16]	<b>PHY Parameter 2[30:16] for Port 1</b> ▪ Bit [14:0]: PHY parameter 2
34h	<b>7Ch (Port 2)</b> 7Ch: Bit[30:16]	<b>PHY Parameter 2[30:16] for Port 2</b> ▪ Bit [14:0]: PHY parameter 2
40h	<b>7Ch (Port 0)</b> 7Ch: Bit[12:8]  <b>90h (Port 0)</b> 90h: Bit[6:0]  <b>78h (Port 0)</b> 78h: Bit[11]  <b>8Ch (Port 0)</b> 8Ch: Bit[9:8]	<p><b>PHY Parameter 2[12:8] for Port 0</b></p> <ul style="list-style-type: none"> <li>▪ Bit [4:0]: PHY parameter 2</li> </ul> <p><b>PHY Parameter 3[6:0] for Port 0</b></p> <ul style="list-style-type: none"> <li>▪ Bit [11:5]: PHY parameter 3</li> </ul> <p><b>Compliance to Detect for Port 0</b></p> <ul style="list-style-type: none"> <li>▪ Bit [13]: compliance to detect</li> </ul> <p><b>TL_CSR[9:8] for Port 0</b></p> <ul style="list-style-type: none"> <li>▪ Bit[15:14]: DO_CHG_DATA_CNT_SEL</li> </ul>
42h	<b>7Ch (Port 1)</b> 7Ch: Bit[12:8]  <b>90h (Port 1)</b> 90h: Bit[6:0]  <b>F0h (Port 1)</b> F0h: Bit[6]  <b>78h (Port 1)</b> 78h: Bit[11]	<p><b>PHY Parameter 2[12:8] for Port 1</b></p> <ul style="list-style-type: none"> <li>▪ Bit [4:0]: PHY parameter 2</li> </ul> <p><b>PHY Parameter 3[6:0] for Port 1</b></p> <ul style="list-style-type: none"> <li>▪ Bit [11:5]: PHY parameter 3</li> </ul> <p><b>Selectable De-emphasis for Port 1</b></p> <ul style="list-style-type: none"> <li>▪ Bit [12]: selectable De-emphasis</li> </ul> <p><b>Compliance to Detect for Port 1</b></p> <ul style="list-style-type: none"> <li>▪ Bit [13]: compliance to detect</li> </ul>

ADDRESS	PCI CFG OFFSET	DESCRIPTION
	<b>8Ch (Port 1)</b> 8Ch: Bit[9:8]	<b>TL_CSR[9:8] for Port 1</b> <ul style="list-style-type: none"> <li>Bit[15:14]: DO_CHG_DATA_CNT_SEL</li> </ul>
44h	<b>7Ch (Port 2)</b> 7Ch: Bit[12:8]  <b>90h (Port 2)</b> 90h: Bit[6:0]  <b>F0h (Port 2)</b> F0h: Bit[6]  <b>78h (Port 2)</b> 78h: Bit[11]  <b>8Ch (Port 2)</b> 8Ch: Bit[9:8]	<b>PHY Parameter 2[12:8] for Port 2</b> <ul style="list-style-type: none"> <li>Bit [4:0]: PHY parameter 2</li> </ul> <b>PHY Parameter 3[6:0] for Port 2</b> <ul style="list-style-type: none"> <li>Bit [11:5]: PHY parameter 3</li> </ul> <b>Selectable De-emphasis for Port 2</b> <ul style="list-style-type: none"> <li>Bit [12]: selectable De-emphasis</li> </ul> <b>Compliance to Detect for Port 2</b> <ul style="list-style-type: none"> <li>Bit [13]: compliance to detect</li> </ul> <b>TL_CSR[9:8] for Port 2</b> <ul style="list-style-type: none"> <li>Bit[15:14]: DO_CHG_DATA_CNT_SEL</li> </ul>
50h	<b>44h (Port 0)</b> 44h: Bit [3]  <b>40h (Port 0)</b> 40h: Bit [24:22] 40h: Bit [25]  40h: Bit [26]  40h: Bit [29:28]	<b>No_Soft_Reset for Port 0</b> <ul style="list-style-type: none"> <li>Bit [0]: No_Soft_Reset</li> </ul> <b>Power Management Capability for Port 0</b> <ul style="list-style-type: none"> <li>Bit [3:1]: AUX Current</li> <li>Bit [4]: read only as 1 to indicate Bridge supports the D1 power management state</li> <li>Bit [5]: read only as 1 to indicate Bridge supports the D2 power management state</li> <li>Bit [7:6]: PME Support for D2 and D1 states</li> </ul>
51h	<b>44h (Port 0)</b> 44h: Bit [31:24]	<b>Power Management Data for Port 0</b> <ul style="list-style-type: none"> <li>Bit [15:8]: read only as Data register</li> </ul>
52h	<b>44h (Port 1)</b> 44h: Bit [3]  <b>40h (Port 1)</b> 40h: Bit [24:22] 40h: Bit [25]  40h: Bit [26]  40h: Bit [29:28]	<b>No_Soft_Reset for Port 1</b> <ul style="list-style-type: none"> <li>Bit [0]: No_Soft_Reset</li> </ul> <b>Power Management Capability for Port 1</b> <ul style="list-style-type: none"> <li>Bit [3:1]: AUX Current</li> <li>Bit [4]: read only as 1 to indicate Bridge supports the D1 power management state</li> <li>Bit [5]: read only as 1 to indicate Bridge supports the D2 power management state</li> <li>Bit [7:6]: PME Support for D2 and D1 states</li> </ul>
53h	<b>44h (Port 1)</b> 44h: Bit [31:24]	<b>Power Management Data for Port 1</b> <ul style="list-style-type: none"> <li>Bit [15:8]: read only as Data register</li> </ul>
54h	<b>44h (Port 2)</b> 44h: Bit [3]  <b>40h (Port 2)</b> 40h: Bit [24:22] 40h: Bit [25]  40h: Bit [26]  40h: Bit [29:28]	<b>No_Soft_Reset for Port 2</b> <ul style="list-style-type: none"> <li>Bit [0]: No_Soft_Reset</li> </ul> <b>Power Management Capability for Port 2</b> <ul style="list-style-type: none"> <li>Bit [3:1]: AUX Current</li> <li>Bit [4]: read only as 1 to indicate Bridge supports the D1 power management state</li> <li>Bit [5]: read only as 1 to indicate Bridge supports the D2 power management state</li> <li>Bit [7:6]: PME Support for D2 and D1 states</li> </ul>
55h	<b>44h (Port 2)</b> 44h: Bit [31:24]	<b>Power Management Data for Port 2</b> <ul style="list-style-type: none"> <li>Bit [15:8]: read only as Data register</li> </ul>
60h	<b>D0h (Port 0)</b> D0h: Bit [28]  <b>40h (Port 0)</b> 40h: Bit[21]  <b>144h (Port 0)</b> 144h: Bit [4]  <b>CCh (Port 0)</b> CCh: Bit [26:24]	<b>Slot Clock Configuration for Port 0</b> <ul style="list-style-type: none"> <li>Bit [1]: when set, the component uses the clock provided on the connector</li> </ul> <b>Device Specific Initialization for Port 0</b> <ul style="list-style-type: none"> <li>Bit [2]: when set, the DSI is required</li> </ul> <b>LPVC Count for Port 0</b> <ul style="list-style-type: none"> <li>Bit [3]: when set, the VC1 is allocated to LPVC of Egress Port 0</li> </ul> <b>Port Number for Port 0</b> <ul style="list-style-type: none"> <li>Bit [6:4]: it represents the logic port numbering for physical Port 0</li> </ul>



ADDRESS	PCI CFG OFFSET	DESCRIPTION
	<b>154h (Port 0)</b> 154h: Bit [7:1]	<b>VC0 TC/VC Map for Port 0</b> <ul style="list-style-type: none"> <li>Bit [15:9]: when set, it indicates the corresponding TC is mapped into VC0</li> </ul>
62h	<b>C0h (Port 1)</b> C0h: Bit [24]  <b>D0h (Port 1)</b> D0h: Bit [28]  <b>40h (Port 1)</b> 40h: Bit [21]  <b>144h (Port 1)</b> 144h: Bit [4]  <b>CCh (Port 1)</b> CCh: Bit [26:24]	<b>PCIe Capability Slot Implemented for Port 1</b> <ul style="list-style-type: none"> <li>Bit [0]: when set, the slot is implemented for Port 1</li> </ul> <b>Slot Clock Configuration for Port 1</b> <ul style="list-style-type: none"> <li>Bit [1]: when set, the component uses the clock provided on the connector</li> </ul> <b>Device Specific Initialization for Port 1</b> <ul style="list-style-type: none"> <li>Bit [2]: when set, the DSI is required</li> </ul> <b>LPVC Count for Port 1</b> <ul style="list-style-type: none"> <li>Bit [3]: when set, the VC1 is allocated to LPVC of Egress Port 1</li> </ul> <b>Port Number for Port 1</b> <ul style="list-style-type: none"> <li>Bit [6:4]: it represents the logic port numbering for physical Port 1</li> </ul>
	<b>154h (Port 1)</b> 154h: Bit [7:1]	<b>VC0 TC/VC Map for Port 1</b> <ul style="list-style-type: none"> <li>Bit [15:9]: when set, it indicates the corresponding TC is mapped into VC0</li> </ul>
64h	<b>C0h (Port 2)</b> C0h: Bit [24]  <b>D0h (Port 2)</b> D0h: Bit [28]  <b>40h (Port 2)</b> 40h: Bit [21]  <b>144h (Port 2)</b> 144h: Bit [4]  <b>CCh (Port 2)</b> CCh: Bit [26:24]	<b>PCIe Capability Slot Implemented for Port 2</b> <ul style="list-style-type: none"> <li>Bit [0]: when set, the slot is implemented for Port 3</li> </ul> <b>Slot Clock Configuration for Port 2</b> <ul style="list-style-type: none"> <li>Bit [1]: when set, the component uses the clock provided on the connector</li> </ul> <b>Device Specific Initialization for Port 2</b> <ul style="list-style-type: none"> <li>Bit [2]: when set, the DSI is required</li> </ul> <b>LPVC Count for Port 2</b> <ul style="list-style-type: none"> <li>Bit [3]: when set, the VC1 is allocated to LPVC of Egress Port 3</li> </ul> <b>Port Number for Port 2</b> <ul style="list-style-type: none"> <li>Bit [6:4]: it represents the logic port numbering for physical Port 2</li> </ul>
	<b>154h (Port 2)</b> 154h: Bit [7:1]	<b>VC0 TC/VC Map for Port 2</b> <ul style="list-style-type: none"> <li>Bit [15:9]: when set, it indicates the corresponding TC is mapped into VC0</li> </ul>
70h	<b>214h (Port 0)</b> 214h: Bit [7:0] 214h: Bit [9:8] 214h: Bit [14:13]  <b>218h (Port 0)</b> 218h: Bit [0]	<b>Power Budgeting Data Register for Port 0</b> <ul style="list-style-type: none"> <li>Bit [7:0]: base power</li> <li>Bit [9:8]: data scale</li> <li>Bit [11:10]: PM state</li> </ul> <b>Power Budget Capability Register for Port 0</b> <ul style="list-style-type: none"> <li>Bit [15]: system allocated</li> </ul>
72h	<b>214h (Port 1)</b> 214h: Bit [7:0] 214h: Bit [9:8] 214h: Bit [14:13]  <b>218h (Port 1)</b> 218h: Bit [0]	<b>Power Budgeting Data Register for Port 1</b> <ul style="list-style-type: none"> <li>Bit [7:0]: base power</li> <li>Bit [9:8]: data scale</li> <li>Bit [11:10]: PM state</li> </ul> <b>Power Budget Capability Register for Port 1</b> <ul style="list-style-type: none"> <li>Bit [15]: system allocated</li> </ul>
74h	<b>214h (Port 2)</b> 214h: Bit [7:0] 214h: Bit [9:8] 214h: Bit [14:13]  <b>218h (Port 2)</b> 218h: Bit [0]	<b>Power Budgeting Data Register for Port 2</b> <ul style="list-style-type: none"> <li>Bit [7:0]: base power</li> <li>Bit [9:8]: data scale</li> <li>Bit [11:10]: PM state</li> </ul> <b>Power Budget Capability Register for Port 2</b> <ul style="list-style-type: none"> <li>Bit [15]: system allocated</li> </ul>

ADDRESS	PCI CFG OFFSET	DESCRIPTION
80h	<b>74h (Port 0)</b> 74h: Bit [14] 74h: Bit [13:8]  <b>70h (Port 0)</b> 70h: Bit[31]  <b>88h (Port 0)</b> 88h: Bit[31:24]	<b>PM Control Parameter for Port 0</b> <ul style="list-style-type: none"> <li>Bit [6] : disable Rx polarity capability</li> <li>Bit [5:4] : L0s enable</li> <li>Bit [3:2] : L1 delay count select</li> <li>Bit [1:0] : D3 enters L1</li> </ul> <b>VGA Decode Enable for Port 0</b> <ul style="list-style-type: none"> <li>Bit [7] : enable VGA decode</li> </ul> <b>XPIP_CSR5[31:24] for Port 0</b> <ul style="list-style-type: none"> <li>Bit[15:8]: XPIP_CSR5[31:24]</li> </ul>
82h	<b>74h (Port 1)</b> 74h: Bit [14] 74h: Bit [13:8]  <b>70h (Port 1)</b> 70h: Bit[31]  <b>88h (Port 1)</b> 88h: Bit[31:24]	<b>PM Control Parameter for Port 1</b> <ul style="list-style-type: none"> <li>Bit [6] : disable Rx polarity capability</li> <li>Bit [5:4] : L0s enable</li> <li>Bit [3:2] : L1 delay count select</li> <li>Bit [1:0] : D3 enters L1</li> </ul> <b>VGA Decode Enable for Port 1</b> <ul style="list-style-type: none"> <li>Bit [7] : enable VGA decode</li> </ul> <b>XPIP_CSR5[31:24] for Port 1</b> <ul style="list-style-type: none"> <li>Bit[15:8]: XPIP_CSR5[31:24]</li> </ul>
84h	<b>74h (Port 2)</b> 74h: Bit [13:8]  74h: Bit [14]  <b>70h (Port 2)</b> 70h: Bit[31]  <b>88h (Port 2)</b> 88h: Bit[31:24]	<b>PM Control Parameter for Port 2</b> <ul style="list-style-type: none"> <li>Bit [1:0] : D3 enters L1</li> <li>Bit [3:2] : L1 delay count select</li> <li>Bit [5:4] : L0s enable</li> <li>Bit [6] : disable Rx polarity capability</li> </ul> <b>VGA Decode Enable for Port 2</b> <ul style="list-style-type: none"> <li>Bit [7] : enable VGA decode</li> </ul> <b>XPIP_CSR5[31:24] for Port 2</b> <ul style="list-style-type: none"> <li>Bit[15:8]: XPIP_CSR5[31:24]</li> </ul>
92h	<b>D4h (Port 1)</b> D4h: Bit [15:0]	<b>Slot Capability 0 of Port 1</b> <ul style="list-style-type: none"> <li>Bit [15:0]: Mapping to the low word of slot capability register</li> </ul>
94h	<b>D4h (Port 2)</b> D4h: Bit [15:0]	<b>Slot Capability 0 of Port 2</b> <ul style="list-style-type: none"> <li>Bit [15:0]: Mapping to the low word of slot capability register</li> </ul>
96h	<b>D4h (Port 3)</b> D4h: Bit [15:0]	<b>Slot Capability 0 of Port 3</b> <ul style="list-style-type: none"> <li>Bit [15:0]: Mapping to the low word of slot capability register</li> </ul>
A2h	<b>D4h (Port 1)</b> D4h: Bit [31:16]	<b>Slot Capability 1 of Port 1</b> <ul style="list-style-type: none"> <li>Bit [15:0]: Mapping to the high word of slot capability register</li> </ul>
A4h	<b>D4h (Port 2)</b> D4h: Bit [31:16]	<b>Slot Capability 1 of Port 2</b> <ul style="list-style-type: none"> <li>Bit [15:0]: Mapping to the high word of slot capability register</li> </ul>
B0h	<b>80h (Port 0)</b> 80h: Bit[15:0]	<b>XPIP_CSR3[15:0] for Port 0</b> <ul style="list-style-type: none"> <li>Bit[15:0]: XPIP_CSR3[15:0]</li> </ul>
B2h	<b>80h (Port 1)</b> 80h: Bit[15:0]	<b>XPIP_CSR3[15:0] for Port 1</b> <ul style="list-style-type: none"> <li>Bit[15:0]: XPIP_CSR3[15:0]</li> </ul>
B4h	<b>80h (Port 2)</b> 80h: Bit[15:0]	<b>XPIP_CSR3[15:0] for Port 2</b> <ul style="list-style-type: none"> <li>Bit[15:0]: XPIP_CSR3[15:0]</li> </ul>
C0h	<b>80h (Port 0)</b> 80h: Bit[31:16]	<b>XPIP_CSR3[31:16] for Port 0</b> <ul style="list-style-type: none"> <li>Bit[15:0]: XPIP_CSR3[31:16]</li> </ul>
C2h	<b>80h (Port 1)</b> 80h: Bit[31:16]	<b>XPIP_CSR3[31:16] for Port 1</b> <ul style="list-style-type: none"> <li>Bit[15:0]: XPIP_CSR3[31:16]</li> </ul>
C4h	<b>80h (Port 2)</b> 80h: Bit[31:16]	<b>XPIP_CSR3[31:16] for Port 2</b> <ul style="list-style-type: none"> <li>Bit[15:0]: XPIP_CSR3[31:16]</li> </ul>
D0h	<b>70h (Port 0)</b> 70h: Bit [11:0] 70h: Bit [12]  <b>8Ch (Port 0)</b> 8Ch: Bit[25:24]	<b>Replay Time-out Counter for Port 0</b> <ul style="list-style-type: none"> <li>Bit [11:0]: replay time-out counter</li> <li>Bit [12]: enable user replay time-out timer</li> </ul> <b>REV_TS_CTR for Port 0</b> <ul style="list-style-type: none"> <li>Bit[14:13]: REV_TS_CTR</li> </ul>
D2h	<b>70h (Port 1)</b> 70h: Bit [11:0] 70h: Bit[12]  <b>8Ch (Port 1)</b> 8Ch: Bit[25:24]	<b>Replay Time-out Counter for Port 1</b> <ul style="list-style-type: none"> <li>Bit [11:0]: relay time-out counter</li> <li>Bit [12]: enable user replay time-out timer</li> </ul> <b>REV_TS_CTR for Port 1</b> <ul style="list-style-type: none"> <li>Bit[14:13]: REV_TS_CTR</li> </ul>

ADDRESS	PCI CFG OFFSET	DESCRIPTION
D4h	<b>70h (Port 2)</b> 70h: Bit [11:0] 70h: Bit[12]  <b>8Ch (Port 2)</b> 8Ch: Bit[25:24]	<b>Replay Time-out Counter for Port 2</b> <ul style="list-style-type: none"> <li>Bit [11:0]: relay time-out counter</li> <li>Bit [12]: enable user replay time-out timer</li> </ul> <b>REV_TS_CTR for Port 2</b> <ul style="list-style-type: none"> <li>Bit[14:13] REV_TS_CTR</li> </ul>
E0h	<b>70h (Port 0)</b> 70h: Bit [29:16] 70h: Bit [30]	<b>Acknowledge Latency Timer for Port 0</b> <ul style="list-style-type: none"> <li>Bit [13:0]: acknowledge latency timer</li> <li>Bit [14]: enable user acknowledge latency timer</li> </ul>
E2h	<b>70h (Port 1)</b> 70h: Bit [29:16] 70h: Bit [30]	<b>Acknowledge Latency Timer for Port 1</b> <ul style="list-style-type: none"> <li>Bit [13:0]: acknowledge latency timer</li> <li>Bit [14]: enable user acknowledge latency timer</li> </ul>
E4h	<b>70h (Port 2)</b> 70h: Bit [29:16] 70h: Bit [30]	<b>Acknowledge Latency Timer for Port 2</b> <ul style="list-style-type: none"> <li>Bit [13:0]: acknowledge latency timer</li> <li>Bit [14]: enable user acknowledge latency timer</li> </ul>
F0h	<b>8Ch (Port 0)</b> 8Ch: Bit[23:16] 8Ch: Bit[10]  <b>8Ch (Port 0)</b> 8Ch: Bit[11]	<b>XPIP_CSR6[23:16][10] for Port 0</b> <ul style="list-style-type: none"> <li>Bit[7:0]: XPIP_CSR6[7:0]</li> <li>Bit[12]: port disable</li> </ul> <b>XPIP_CSR[11] for Port 0</b> <ul style="list-style-type: none"> <li>Bit[14]: reset sel</li> </ul>
F2h	<b>8Ch (Port 1)</b> 8Ch: Bit[23:16] 8Ch: Bit[10]  <b>9Ch (Port 1)</b> 9Ch: Bit[0]  <b>8Ch (Port 1)</b> 8Ch: Bit[11]	<b>XPIP_CSR6[23:16][10] for Port 1</b> <ul style="list-style-type: none"> <li>Bit[7:0]: XPIP_CSR6[7:0]</li> <li>Bit[12]: port disable</li> </ul> <b>Device Specific PM Capability for Port 1</b> <ul style="list-style-type: none"> <li>Bit[13]: device specific PM capability</li> </ul> <b>XPIP_CSR[11] Port 1</b> <ul style="list-style-type: none"> <li>Bit[14]: reset sel</li> </ul>
F4h	<b>8Ch (Port 2)</b> 8Ch: Bit[23:16] 8Ch: Bit[10]  <b>9Ch (Port 2)</b> 9Ch: Bit[0]  <b>8Ch (Port 2)</b> 8Ch: Bit[11]	<b>XPIP_CSR6[23:16][10] for Port 2</b> <ul style="list-style-type: none"> <li>Bit[7:0]: XPIP_CSR6[7:0]</li> <li>Bit[12]: port disable</li> </ul> <b>Device Specific PM Capability for Port 2</b> <ul style="list-style-type: none"> <li>Bit[13]: device specific PM capability</li> </ul> <b>XPIP_CSR[11] for Port 2</b> <ul style="list-style-type: none"> <li>Bit[14]: reset sel</li> </ul>
100h	<b>15Ch (Port 0)</b> 15Ch: Bit [22:16]  <b>160h (Port 0)</b> 160h: Bit [7:0]	<b>VC1 MAX Time Slot for Port 0</b> <ul style="list-style-type: none"> <li>Bit [6:0]: the maximum time slot supported by VC1</li> </ul> <b>TC/VC Map for Port 0</b> <ul style="list-style-type: none"> <li>Bit [15:8]: when set, it indicates the corresponding TC is mapped into VC1</li> </ul>
102h	<b>15Ch (Port 1)</b> 15Ch: Bit [22:16]  <b>160h (Port 1)</b> 160h: Bit [7:0]	<b>VC1 MAX Time Slot for Port 1</b> <ul style="list-style-type: none"> <li>Bit [6:0]: the maximum time slot supported by VC1</li> </ul> <b>TC/VC Map for Port 1</b> <ul style="list-style-type: none"> <li>Bit [15:8]: when set, it indicates the corresponding TC is mapped into VC1</li> </ul>
104h	<b>15Ch (Port 2)</b> 15Ch: Bit [22:16]  <b>160h (Port 2)</b> 160h: Bit [7:0]	<b>VC1 MAX Time Slot for Port 2</b> <ul style="list-style-type: none"> <li>Bit [6:0]: the maximum time slot supported by VC1</li> </ul> <b>TC/VC Map for Port 2</b> <ul style="list-style-type: none"> <li>Bit [15:8]: when set, it indicates the corresponding TC is mapped into VC1</li> </ul>
110h	<b>98h (Port 0)</b> 98h: Bit[27:24]  <b>244h (Port 0)</b> 244h: Bit[1] 244h: Bit[3] 244h: Bit[4]  <b>33Ch (Port 0)</b> 33Ch: Bit[7:0]	<b>L1 PM CSR for Port 0</b> <ul style="list-style-type: none"> <li>Bit[3:0]: L1 PM option[3:0]</li> </ul> <b>L1 PM Substates Capability for Port 0</b> <ul style="list-style-type: none"> <li>Bit[4]: pci_pm_L1.1 sup</li> <li>Bit[5]: aspm_pm_L1.1 sup</li> <li>Bit[6]: L1pm_substate_sup</li> </ul> <b>LTSSM_CSR for Port 0</b> <ul style="list-style-type: none"> <li>Bit[15:8]: ltssm_csr</li> </ul>

ADDRESS	PCI CFG OFFSET	DESCRIPTION
112h	<b>98h (Port 1)</b> 98h: Bit[27:24]  <b>244h (Port 1)</b> 244h: Bit[1] 244h: Bit[3] 244h: Bit[4]  <b>33Ch (Port 1)</b> 33Ch: Bit[7:0]	<b>L1 PM CSR for Port 1</b> <ul style="list-style-type: none"> <li>Bit[3:0]: L1 PM option[3:0]</li> </ul> <b>L1 PM Substates Capability for Port 1</b> <ul style="list-style-type: none"> <li>Bit[4]: pci_pm_L1.1 sup</li> <li>Bit[5]: aspm_pm_L1.1 sup</li> <li>Bit[6]: L1pm_substate_sup</li> </ul> <b>LTSSM_CSR for Port 1</b> <ul style="list-style-type: none"> <li>Bit[15:8]: ltssm_csr</li> </ul>
114h	<b>98h (Port 2)</b> 98h: Bit[27:24]  <b>244h (Port 2)</b> 244h: Bit[1] 244h: Bit[3] 244h: Bit[4]  <b>33Ch (Port 2)</b> 33Ch: Bit[7:0]	<b>L1 PM CSR for Port 2</b> <ul style="list-style-type: none"> <li>Bit[3:0]: L1 PM option[3:0]</li> </ul> <b>L1 PM Substates Capability for Port 2</b> <ul style="list-style-type: none"> <li>Bit[4]: pci_pm_L1.1 sup</li> <li>Bit[5]: aspm_pm_L1.1 sup</li> <li>Bit[6]: L1pm_substate_sup</li> </ul> <b>LTSSM_CSR for Port 2</b> <ul style="list-style-type: none"> <li>Bit[15:8]: ltssm_csr</li> </ul>
120h	<b>340h (Port 0)</b> 340h: Bit [15:0]	<b>Hotplug_CSR for Port 0</b> <ul style="list-style-type: none"> <li>Bit [15:0]: hotplug csr</li> </ul>
122h	<b>340h (Port 1)</b> 340h: Bit [15:0]	<b>Hotplug_CSR for Port 1</b> <ul style="list-style-type: none"> <li>Bit [15:0]: hotplug csr</li> </ul>
124h	<b>340h (Port 2)</b> 340h: Bit [15:0]	<b>Hotplug_CSR for Port 2</b> <ul style="list-style-type: none"> <li>Bit [15:0]: hotplug csr</li> </ul>
130h	<b>340h (Port 0)</b> 340h: Bit [31:16]	<b>MAC_CSR1 for Port 0</b> <ul style="list-style-type: none"> <li>Bit [15:0]: mac csr1</li> </ul>
132h	<b>340h (Port 1)</b> 340h: Bit [31:16]	<b>MAC_CSR1 for Port 1</b> <ul style="list-style-type: none"> <li>Bit [15:0]: mac csr1</li> </ul>
134h	<b>340h (Port 2)</b> 340h: Bit [31:16]	<b>MAC_CSR1 for Port 2</b> <ul style="list-style-type: none"> <li>Bit [15:0]: mac csr1</li> </ul>
140h	<b>350h (Port 1~2)</b> 350h: Bit [2:1]	<b>CPLD Flow Control Enable for Port 1~2</b> <ul style="list-style-type: none"> <li>Bit [1]: Port 1 CPLD flow control enable</li> <li>Bit [2]: Port 2 CPLD flow control enable</li> </ul>
142h	<b>354h (Port 1~2)</b> 354h: Bit [15:0]	<b>X1 CPLD Flow Control Threshold for Port 1~2</b> <ul style="list-style-type: none"> <li>Bit [15:0]: x1 CPLD flow control threshold</li> </ul>
144h	<b>354h (Port 1~2)</b> 354h: Bit [31:16]	<b>X2 CPLD Flow Control Threshold for Port 1~2</b> <ul style="list-style-type: none"> <li>Bit [15:0]: x2 CPLD flow control threshold</li> </ul>
146h	<b>358h (Port 1~2)</b> 358h: Bit [15:0]	<b>X4 CPLD Flow Control Threshold for Port 1~2</b> <ul style="list-style-type: none"> <li>Bit [15:0]: x4 CPLD flow control threshold</li> </ul>
150h	<b>360h (Port 0)</b> 360h: Bit [0]	<b>PWR_SAVING Disable for Port 0</b> <ul style="list-style-type: none"> <li>Bit [0]: pwr_saving disable for Port 0</li> </ul>
152h	<b>360h (Port 1)</b> 360h: Bit [0]	<b>PWR_SAVING Disable for Port 1</b> <ul style="list-style-type: none"> <li>Bit [0]: pwr_saving disable for Port 1</li> </ul>
154h	<b>360h (Port 2)</b> 360h: Bit [0]	<b>PWR_SAVING Disable for Port 2</b> <ul style="list-style-type: none"> <li>Bit [0]: pwr_saving disable for Port 2</li> </ul>

## 6.2 SMBUS INTERFACE

The Packet Switch provides the System Management Bus (SMBus), a two-wire interface through which a simple device can communicate with the rest of the system. The SMBus interface on the Packet Switch is a bi-directional slave interface. It can receive data from the SMBus master or send data to the master. The interface allows full access to the configuration registers. A SMBus master, such as the processor or other SMBus devices, can read or write to every RW configuration register (read/write register). In addition, the RO and HwInt registers (read-only and hardware initialized registers) that can be auto-loaded by the EEPROM interface can also be read and written by the SMBus interface. This feature allows increases in the system expandability and flexibility in system implementation.

**Figure 6-1 SMBus Architecture Implementation**

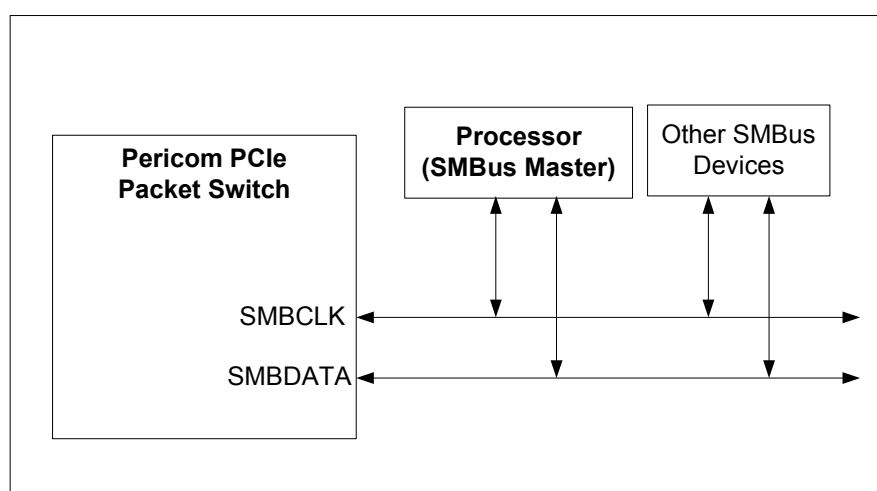

The SMBus interface on the Packet Switch consists of one SMBus clock pin (SCL\_I2C), a SMBus data pin (SDA\_I2C), and 3 SMBus address pins (GPIO[7:5]). The SMBus clock pin provides or receives the clock signal. The SMBus data pin facilitates the data transmission and reception. Both of the clock and data pins are bi-directional. The SMBus address pins determine the address to which the Packet Switch responds to. The SMBus address pins generate addresses according to the following table:

**Table 6-1 SMBus Address Pin Configuration**

BIT	SMBus Address
0	GPIO[5]
1	GPIO[6]
2	GPIO[7]
3	1
4	0
5	1
6	1

Software can change the SMBus Slave address, by programming the SMBus/I2C Control Register SMBus/I2C Device Address field (Upstream Port, offset 344h [7:1]).

The PI7C9X2G308GP SMBus Slave interface supports three command protocols for register access:

- Block Write
- Block Read

- Block Read - Block Write Process Call

The PI7C9X2G308GP also supports Packet Error Checking and Packet Error Code (PEC) generation, as explained in the SMBus v2.0.

PI7C9X2G308GP supports three commands:

- Block Write (command BEh) is used to write CFG registers
- Block Write (command BAh), followed by Block Read (command BDh), are used to read CFG registers
- Block Read - Block Write Process Call (commands BAh, CDh) can also be used to read CFG registers

### 6.2.1 SMBUS BLOCK WRITE

The Block Write command is used to write to the PI7C9X2G308GP registers. General SMBus Block Writes are illustrated in Figure 6-2 and Figure 6-3. Table 6-2 explains the elements used in Figure 6-2 and Figure 6-3.

**Figure 6-2 SMBus Block Write Command Format, to Write to a PI7C9X2G308GP Register without PEC**

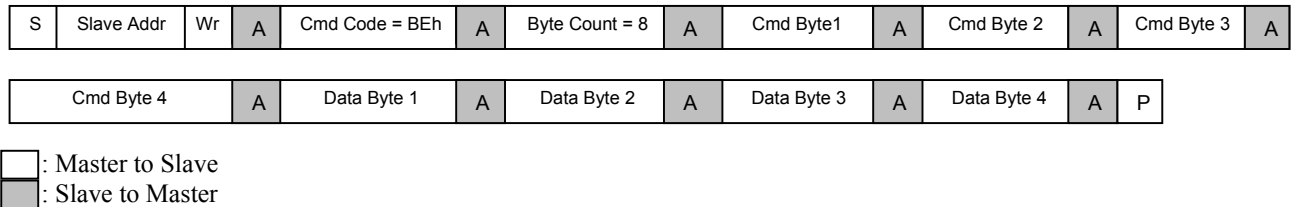

**Figure 6-3 SMBus Block Write Command Format, to Write to a PI7C9X2G308GP Register with PEC**

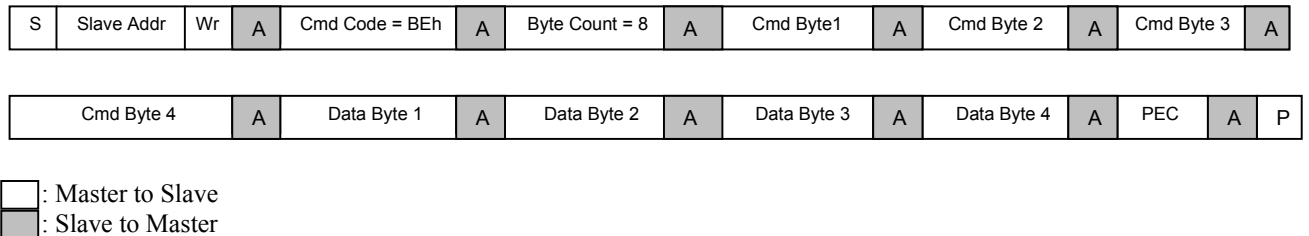

Block Write transactions that are received with incorrect Cmd Code are NACKed, starting from the wrong byte setting, and including subsequent bytes in the packet. For example, if the Byte Count value is not 8, the PI7C9X2G308GP NACKs the byte corresponding to the Byte Count value, as well as any Data bytes following within the same packet.

The byte after Data Byte 4, if present, is taken as the PEC byte, and if present, the PEC is checked. If a packet fails Packet Error Checking, the PI7C9X2G308GP drops the packet (ignores the Write), and returns NACK for the PEC byte, to the SMBus Master. Packet Error Checking can be disabled, by Setting the SMBus/I<sup>2</sup>C Control Register PEC Check Disable bit (Upstream Port, offset 344h[9]). The Byte Count value, by definition, does not include the PEC byte.

**Table 6-2 Bytes for SMBus Block Write**

Field (Byte) On Bus	Bit(s)	Value / Description
S	1	START condition
P	1	STOP condition
A	1	Acknowledge (this bit position may be 0 for an ACK or 1 for a NACK)
Command Code	7:0	BEh for Block Write

Field (Byte) On Bus	Bit(s)	Value / Description									
Byte Count	7:0	<b>08h</b> = 8 bytes to follow (4 Command and 4 Data bytes). The PEC byte is not counted.									
Command Byte 1	7:3	<b>Reserved</b>									
	2:0	<b>Command</b> 011b = Write register 100b = Read register									
Command Byte 2	7:4	<b>Reserved</b>									
	3:0	<b>Port Select[4:1]</b> 2 <sup>nd</sup> Command byte, bits [3:0], and 3 <sup>rd</sup> Command byte, bit 7, combine to form a 5-bit Port Select.									
Command Byte 3	7	<b>Port Select[0]</b> 2 <sup>nd</sup> Command byte, bits [3:0], and 3 <sup>rd</sup> Command byte, bit 7, combine to form a 5-bit Port Select. Port Select[4:0] is used to select Port to access. 0... Port 0 1... Port 1 2... Port 2									
	6	<b>Reserved</b>									
	5:2	<b>Byte Enable</b>  <table border="1"> <thead> <tr> <th>Bit</th> <th>Description</th> </tr> </thead> <tbody> <tr> <td>2</td> <td>Byte Enable for Data Byte 4 (PI7C9X2G308GP register bits [7:0])</td> </tr> <tr> <td>3</td> <td>Byte Enable for Data Byte 3 (PI7C9X2G308GP register bits [15:8])</td> </tr> <tr> <td>4</td> <td>Byte Enable for Data Byte 2 (PI7C9X2G308GP register bits [23:16])</td> </tr> <tr> <td>5</td> <td>Byte Enable for Data Byte 1 (PI7C9X2G308GP register bits [31:24])</td> </tr> </tbody> </table> 0 = Corresponding PI7C9X2G308GP register byte will not be modified 1 = Corresponding PI7C9X2G308GP register byte will be modified	Bit	Description	2	Byte Enable for Data Byte 4 (PI7C9X2G308GP register bits [7:0])	3	Byte Enable for Data Byte 3 (PI7C9X2G308GP register bits [15:8])	4	Byte Enable for Data Byte 2 (PI7C9X2G308GP register bits [23:16])	5
Bit	Description										
2	Byte Enable for Data Byte 4 (PI7C9X2G308GP register bits [7:0])										
3	Byte Enable for Data Byte 3 (PI7C9X2G308GP register bits [15:8])										
4	Byte Enable for Data Byte 2 (PI7C9X2G308GP register bits [23:16])										
5	Byte Enable for Data Byte 1 (PI7C9X2G308GP register bits [31:24])										
Command Byte 4	1:0	<b>PI7C9X2G308GP Register Address [11:10]</b>									
	7:0	<b>PI7C9X2G308GP Register Address [9:2]</b> Note: Address bits[1:0] are fixed to 0.									
Data Byte 1	7:0	<b>Data write to register bits [31:24]</b>									
Data Byte 2	7:0	<b>Data write to register bits [23:16]</b>									
Data Byte 3	7:0	<b>Data write to register bits [15:8]</b>									
Data Byte 4	7:0	<b>Data write to register bits [7:0]</b>									
PEC	7:0	<b>Packet Error Code</b>									

Table 6-3 is a sample to write SSID/SSVID register (offset F8h) in Port 1. The register value is 1234\_5678h, with all bytes enabled, and without PEC. The default SMBus Address is 1101000b.

**Table 6-3 Sample SMBus Block Write Byte Sequence**

Byte Number	Byte Type	Value	Description
1	Address	D0h	Bits [7:1] for the PI7C9X2G308GP default Slave address of 68h, with bit 0 Cleared to indicate a Write.
2	Command Code	BEh	Command Code for register Write, using a Block Write
3	Byte Count	08h	Byte Count. Four Command Bytes and Four Data Bytes
4	Command Byte 1	03h	For Write command
5	Command Byte 2	00h	Bits [3:0] - Port Select [4:1] (for Port 1)
6	Command Byte 3	BCh	Bit 7 is Port Select[0] Bit 6 is reserved Bits [5:2] are the for Byte Enables; all are active Bits [1:0] are register Address bits [11:10]
7	Command Byte 4	3Eh	PI7C9X2G308GP Register Address bits [9:2] (for offset F8h)
8	Data Byte 1	12h	Data Byte for register bits [31:24]
9	Data Byte 2	34h	Data Byte for register bits [23:16]
10	Data Byte 3	56h	Data Byte for register bits [15:8]
11	Data Byte 4	78h	Data Byte for register bits[7:0]

## 6.2.2 SMBUS BLOCK READ

A Block Read command is used to read PI7C9X2G308GP CFG registers. Similar to CFG register Reads using I<sup>2</sup>C, a SMBus Write sequence must first be performed to select the register to read, followed by a SMBus Read of the corresponding register. There are two ways a PI7C9X2G308GP register can be read:

- Use a Block Write, followed by a Block Read. The Block Write sets up the parameters including Port Number, register address and Byte Enables, and the Block Read performs the actual Read operation.
- Use a Block Read - Block Write Process Call. This command is defined by the SMBus v2.0, and performs a Block Write and Block Read, using a single command. The Block Write portion of the message sets up the register to be read, and then a repeated START followed by the Block Read portion of the message returns the register data specified by the Block Write

The PI7C9X2G308GP always NACKs any incorrect command sequences, starting with the wrong Byte. Upon receiving the Block Read command, the PI7C9X2G308GP returns a PEC to the Master, if after the 4th byte of register data, the Master still requests one more Byte. As a Slave, the PI7C9X2G308GP recognizes the end of the Master's Read cycle, by observing the Master's NACK response for the last Data Byte transmitted by the PI7C9X2G308GP.

Incorrect command sequences are always NACK, starting with the byte that is incorrect. (Refer to Table 6-4.) On the Block Read command, a PEC is returned to the Master, if after the 4th byte of CSR data, the return Master still requests for one additional byte. As a Slave, the PI7C9X2G308GP will know the end of the Master Read cycle, by observing the NACK for the last byte read from the Master.

**Figure 6-4 SMBus Block Write to Set up Read, and Resulting Read that Returns CFG Register Value**

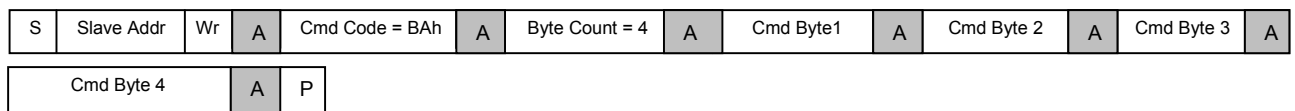

### A Block Write to set up Read

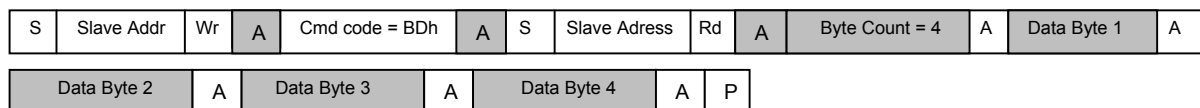

### A Block Read which returns CFG Register Value

□ : Master to Slave  
 ■ : Slave to Master

**Table 6-4 Bytes for SMBus Block Read**

Field (Byte) On Bus	Bit(s)	Value/Description
S	1	START condition
P	1	STOP condition
A	1	Acknowledge (this bit position may be 0 for an ACK or 1 for a NACK)
Command Code	7:0	BAh, to set up Read, using Block Writes
Byte Count	7:0	04h, 4 Command bytes
Command Byte 1	7:3	Reserved
	2:0	Command 011b = Write register 100b = Read register
Command Byte 2	7:4	Reserved
	3:0	Port Select[4:1] 2 <sup>nd</sup> Command byte, bits [3:0], and 3 <sup>rd</sup> Command byte, bit 7, combine to form a 5-bit Port Select.



Field (Byte) On Bus	Bit(s)	Value/ Description									
Command Byte 3	7	<b>Port Select[0]</b> 2nd Command byte, bits [3:0], and 3rd Command byte, bit 7, combine to form a 5-bit Port Select. Port Select[4:0] is used to select Port to access. 0... Port 0 1... Port 1 2... Port 2									
	6	<b>Reserved</b>									
	5:2	<b>Byte Enable</b>  <table border="1"> <thead> <tr> <th>Bit</th> <th>Description</th> </tr> </thead> <tbody> <tr> <td>2</td> <td>Byte Enable for Data Byte 4 (PI7C9X2G308GP register bits [7:0])</td> </tr> <tr> <td>3</td> <td>Byte Enable for Data Byte 3 (PI7C9X2G308GP register bits [15:8])</td> </tr> <tr> <td>4</td> <td>Byte Enable for Data Byte 2 (PI7C9X2G308GP register bits [23:16])</td> </tr> <tr> <td>5</td> <td>Byte Enable for Data Byte 1 (PI7C9X2G308GP register bits [31:24])</td> </tr> </tbody> </table> 0 = Corresponding PI7C9X2G308GP register byte will not be modified 1 = Corresponding PI7C9X2G308GP register byte will be modified	Bit	Description	2	Byte Enable for Data Byte 4 (PI7C9X2G308GP register bits [7:0])	3	Byte Enable for Data Byte 3 (PI7C9X2G308GP register bits [15:8])	4	Byte Enable for Data Byte 2 (PI7C9X2G308GP register bits [23:16])	5
Bit	Description										
2	Byte Enable for Data Byte 4 (PI7C9X2G308GP register bits [7:0])										
3	Byte Enable for Data Byte 3 (PI7C9X2G308GP register bits [15:8])										
4	Byte Enable for Data Byte 2 (PI7C9X2G308GP register bits [23:16])										
5	Byte Enable for Data Byte 1 (PI7C9X2G308GP register bits [31:24])										
	1:0	<b>PI7C9X2G308GP Register Address [11:10]</b>									
Command Byte 4	7:0	<b>PI7C9X2G308GP Register Address [9:2]</b>  Note: Address bits[1:0] are fixed to 0.									
Command Code	7:0	<b>BDh for Block Read</b>									
Data Byte 1	7:0	<b>Return value for CFG register bits [31:24]</b>									
Data Byte 2	7:0	<b>Return value for CFG register bits [23:16]</b>									
Data Byte 3	7:0	<b>Return value for CFG register bits [15:8]</b>									
Data Byte 4	7:0	<b>Return value for CFG register bits [7:0]</b>									

Table 6-5, Table 6-6, Table 6-7 and Table 6-8 are a sample to Read SSID/SSVID register (offset F8h) in Port 1. The register value is 0000\_0000h, with all bytes enabled, and without PEC. The default SMBus Address is 1101000b.

**Table 6-5 SMBus Block Write Portion**

Byte Number	Byte Type	Value	Description
1	Address	D0h	Bits [7:1] for the PI7C9X2G308GP default Slave address of 68h, with bit 0 Cleared to indicate a Write.
2	Command Code	BAh	Command Code for register Write, using a Block Write
3	Byte Count	04h	Byte Count. Four Command Bytes
4	Command Byte 1	04h	For Read command
5	Command Byte 2	00h	Bits [3:0] - Port Select [4:1] (for Port 1)
6	Command Byte 3	BCh	Bit 7 is Port Select[0] Bit 6 is reserved Bits [5:2] are the for Byte Enables; all are active Bits [1:0] are register Address bits [11:10]
7	Command Byte 4	3Eh	PI7C9X2G308GP Register Address bits [9:2] (for offset F8h)

**Table 6-6 SMBus Block Read Portion**

Byte Number	Byte Type	Value	Description
1	Address	D0h	Bits [7:1] value for the PI7C9X2G308GP Slave address of 68h, with bit 0 Cleared to indicate to indicate a Write.
2	Block Read Command Code	BDh	Command code for Block Read of PI7C9X2G308GP registers.

**Table 6-7 SMBus Read Command following Repeat START from Master**

Byte Number	Byte Type	Value	Description
1	Address	D1h	Bits [7:1] value for the PI7C9X2G308GP Slave address of 68h, with bit 0 Set to indicate a Read.

**Table 6-8 SMBus Return Bytes**

Byte Number	Byte Type	Value	Description
1	Byte Count	04h	Four Bytes in register
2	Data Byte 1	00h	Register data [31:24]
3	Data Byte 2	00h	Register data [23:16]
4	Data Byte 3	00h	Register data [15:8]
5	Data Byte 4	00h	Register data [7:0]

### 6.2.3 CSR READ, USING SMBUS BLOCK READ – BLOCK WRITE PROCESS CALL

A general SMBus Block Read - Block Write Process Call sequence is illustrated in Figure 6-5. Alternatively, a general SMBus Block Read - Block Write Process Call with PEC sequence is illustrated in Figure 6-6.

Using this command, the register to be read can be set up and read back with one SMBus cycle (a transaction with a START and ending in STOP). There is no STOP condition before the repeated START condition. The command format for the Block Write part of this command has the same sequence as in Table 6-5, except that the Command Code changes to CDh, as illustrated below. Other Bytes remain the same as used in the sequence for SMBus Block Write followed by Block Read. Table 6-9 lists the Command format for Block Read.

**Figure 6-5 CSR Read Operation Using SMBus Block Read – Block Write Process Call**

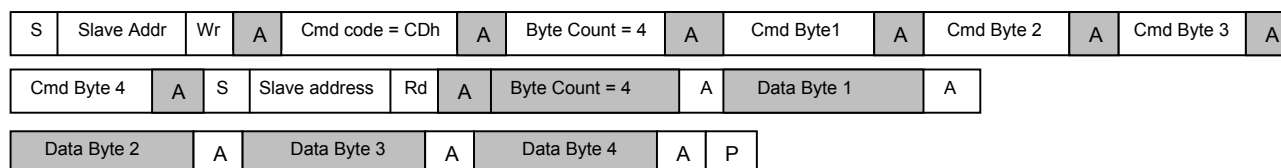

□: Master to Slave  
■: Slave to Master

**Figure 6-6 CSR Read Operation Using SMBus Block Read – Block Write Process Call with PEC**

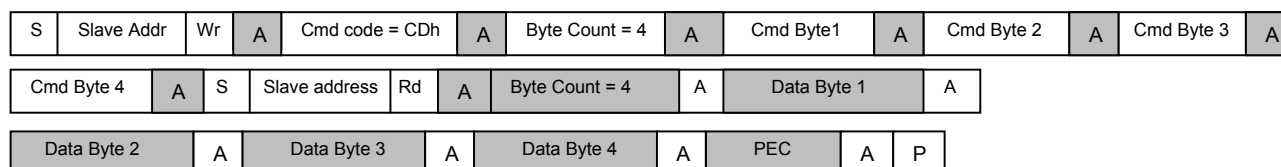

□: Master to Slave  
■: Slave to Master

**Table 6-9 Command Format for SMBus Block Read**

Field (Byte) On Bus	Bit(s)	Value / Description
Command Code	7:0	CDh for Block Read (Process Call Read)

### 6.3 I<sup>2</sup>C SLAVE INTERFACE

Inter-Integrated Circuit (I<sup>2</sup>C) is a bus used to connect Integrated Circuits (ICs). Multiple ICs can be connected to an I<sup>2</sup>C Bus, and I<sup>2</sup>C devices that have I<sup>2</sup>C mastering capability can initiate a Data transfer. I<sup>2</sup>C is used for Data transfers between ICs at relatively low rates (100 Kbps), and is used in a variety of applications. For further details regarding I<sup>2</sup>C Buses, refer to the *I<sup>2</sup>C Bus v2.1*.

The PI7C9X2G308GP is an I<sup>2</sup>C Slave. Slave operations allow the PI7C9X2G308GP Configuration registers to be read from or written to by an I<sup>2</sup>C Master, external from the device. I<sup>2</sup>C is a sideband mechanism that allows the device Configuration registers to be programmed, read from, or written to, independent of the PCI Express upstream Link.

**Figure 6-7 Standard Devices to I<sup>2</sup>C Bus Connection Block Diagram**

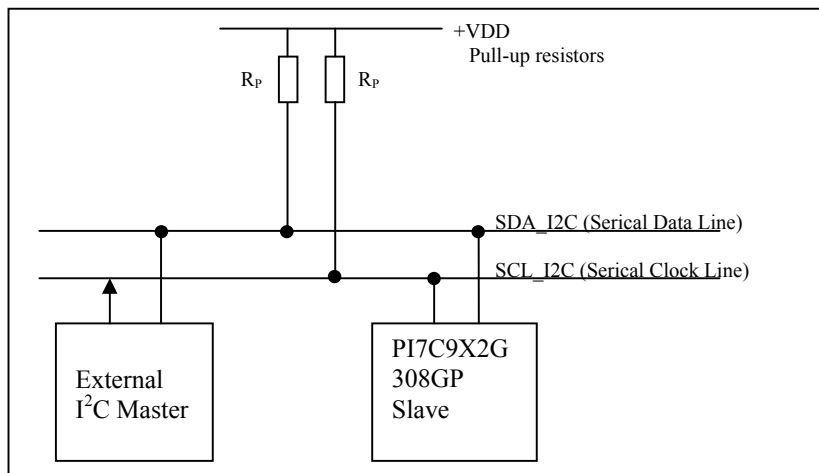

The I<sup>2</sup>C interface on the Packet Switch consists of a I<sup>2</sup>C clock pin (SCL\_I2C), a I<sup>2</sup>C data pin (SDA\_I2C), and 3 I<sup>2</sup>C address pins (GPIO[7:5]). The I<sup>2</sup>C clock pin provides or receives the clock signal. The I<sup>2</sup>C data pin facilitates the data transmission and reception. Both of the clock and data pins are bi-directional. The I<sup>2</sup>C address pins determine the address to which the Packet Switch responds to. The I<sup>2</sup>C address pins generate addresses according to the following table:

**Table 6-10 I<sup>2</sup>C Address Pin Configuration**

BIT	I2C Address
0	GPIO[5]
1	GPIO[6]
2	GPIO[7]
3	1
4	0
5	1
6	1

Software can change the I<sup>2</sup>C Slave address, by programming the SMBus/I<sup>2</sup>C Control Register SMBus/I<sup>2</sup>C Device Address field (Upstream Port, offset 344h [7:1]).

### 6.3.1 I<sup>2</sup>C REGISTER WRITE ACCESS

The PI7C9X2G308GP Configuration registers can be read from and written to, based upon I<sup>2</sup>C register Read and Write operations, respectively. An I<sup>2</sup>C Write packet consists of Address Phase bytes and Command Phase bytes, followed by one to four additional I<sup>2</sup>C Data bytes. Table 6-11 defines mapping of the I<sup>2</sup>C Data bytes to the Configuration register Data bytes.

The I<sup>2</sup>C packet starts with the S (START condition) bit. Data bytes are separated by the A (Acknowledge Control Packet (ACK)) or N (Negative Acknowledge (NAK)) bit. The packet ends with the P (STOP condition) bit.

If the Master generates an invalid command, the targeted PI7C9X2G308GP register is not modified.

The PI7C9X2G308GP considers the 1st Data byte of the 4-byte Data phase, following the four Command bytes in the Command phase, as register Byte 3 (bits [31:24]). The next three Data bytes access register Bytes 2 through 0, respectively. Four Data bytes are required, regardless of the Byte Enable Settings in the Command phase. The Master can then generate either a STOP condition (to finish the transfer) or a repeated START condition (to start a new transfer). If the I<sup>2</sup>C Master sends more than the four Data bytes (violating PI7C9X2G308GP protocol), further details regarding I<sup>2</sup>C protocol, the PI7C9X2G308GP returns a NAK for the extra Data byte(s).

Table 6-12 describes each I<sup>2</sup>C Command byte for Write access. In the packet described in Figure 6-8, Command Bytes 0 through 3 for Writes follow the format specified in Table 6-12.

**Table 6-11 I<sup>2</sup>C Register Write Access**

I <sup>2</sup> C Data Byte Order	PCI Express Configuration Register Byte
0	Written to register Byte 3
1	Written to register Byte 2
2	Written to register Byte 1
3	Written to register Byte 0

**Table 6-12 I<sup>2</sup>C Command Format for Write Access**

Byte	Bit(s)	Description										
1 <sup>st</sup> (0)	7:3	<b>Reserved</b>										
	2:0	<b>Command</b> 011b = Write register										
2 <sup>nd</sup> (1)	7:4	<b>Reserved</b>										
	3:0	<b>Port Select[4:1]</b> 2 <sup>nd</sup> Command byte, bits [3:0], and 3 <sup>rd</sup> Command byte, bit 7, combine to form a 5-bit Port Select.										
3 <sup>rd</sup> (2)	7	<b>Port Select[0]</b> 2 <sup>nd</sup> Command byte, bits [3:0], and 3 <sup>rd</sup> Command byte, bit 7, combine to form a 5-bit Port Select. Port Select[4:0] is used to select Port to access. 0... Port 0 1... Port 1 2... Port 2										
	6	<b>Reserved</b>										
	5:2	<b>Byte Enable</b>  <table border="0"> <tr> <td><b>Bit</b></td> <td><b>Description</b></td> </tr> <tr> <td>2</td> <td>Byte Enable for Data Byte 4 (PI7C9X2G308GP register bits [7:0])</td> </tr> <tr> <td>3</td> <td>Byte Enable for Data Byte 3 (PI7C9X2G308GP register bits [15:8])</td> </tr> <tr> <td>4</td> <td>Byte Enable for Data Byte 2 (PI7C9X2G308GP register bits [23:16])</td> </tr> <tr> <td>5</td> <td>Byte Enable for Data Byte 1 (PI7C9X2G308GP register bits [31:24])</td> </tr> </table> 0 = Corresponding PI7C9X2G308GP register byte will not be modified 1 = Corresponding PI7C9X2G308GP register byte will be modified	<b>Bit</b>	<b>Description</b>	2	Byte Enable for Data Byte 4 (PI7C9X2G308GP register bits [7:0])	3	Byte Enable for Data Byte 3 (PI7C9X2G308GP register bits [15:8])	4	Byte Enable for Data Byte 2 (PI7C9X2G308GP register bits [23:16])	5	Byte Enable for Data Byte 1 (PI7C9X2G308GP register bits [31:24])
	<b>Bit</b>	<b>Description</b>										
2	Byte Enable for Data Byte 4 (PI7C9X2G308GP register bits [7:0])											
3	Byte Enable for Data Byte 3 (PI7C9X2G308GP register bits [15:8])											
4	Byte Enable for Data Byte 2 (PI7C9X2G308GP register bits [23:16])											
5	Byte Enable for Data Byte 1 (PI7C9X2G308GP register bits [31:24])											
1:0	<b>PI7C9X2G308GP Register Address [11:10]</b>											
4 <sup>th</sup> (3)	7:0	<b>PI7C9X2G308GP Register Address [9:2]</b> Note: Address bits[1:0] are fixed to 0.										

Figure 6-8 I<sup>2</sup>C Write Packet

I<sup>2</sup>C Write Packet Address Phase Byte

Address Cycle			
START	7654321	0	ACK/NAK
S	Slave Address [7:1]	Read/Write Bit 0 = Write	A

I<sup>2</sup>C Write Packet Command Phase Byte

Command Cycle							
76543210	ACK/NAK	76543210	ACK/NAK	76543210	ACK/NAK	76543210	ACK/NAK
Command Byte 0	A	Command Byte 1	A	Command Byte 2	A	Command Byte 3	A

I<sup>2</sup>C Write Packet Data Phase Byte

Write Cycle								
76543210	ACK/NAK	76543210	ACK/NAK	76543210	ACK/NAK	76543210	ACK/NAK	STOP
Register Byte 3	A	Register Byte 2	A	Register Byte 1	A	Register Byte 0	A	P

The following tables illustrate a sample I<sup>2</sup>C packet for writing the PI7C9X2G308GP SSID/SSVID register (offset F8h) for Port 0, with data 1234\_5678h.

*Note:* The PI7C9X2G308GP has a default I<sup>2</sup>C Slave address [6:0] value of 68h, with the GPIO[7:5] input having a value of 000. The byte sequence on the I<sup>2</sup>C Bus, as listed in the following tables, occurs after the START and before the STOP bits, by which the I<sup>2</sup>C Master frames the transfer.

Figure 6-9 I<sup>2</sup>C Register Write Access Example

I<sup>2</sup>C Register Write Access Example – Address Cycle

Phase	Value	Description
Address	D0h	Bits [7:1] for PI7C9X2G308GP I <sup>2</sup> C Slave Address (68h) with last bit (bit 0) for Write = 0

I<sup>2</sup>C Register Write Access Example – Command Cycle

Byte	Value	Description
0	03h	[7:3] Reserved [2:0] Command, 011b = Write register
1	00h for Port 0	[7:4] Reserved [3:0] Port Select[4:1]
2	3Ch for Port 0	[7] Port Select[0] [6] Reserved [5:2] Byte Enable, all active. [1:0] PI7C9X2G308GP Register Address, Bits [11:10]
3	3Eh	[7:0] PI7C9X2G308GP Register Address, Bits [9:2]

I<sup>2</sup>C Register Write Access Example – Data Cycle

Byte	Value	Description
0	12h	Data to Write for Byte 3
1	34h	Data to Write for Byte 2
2	56h	Data to Write for Byte 1
3	78h	Data to Write for Byte 0

**Figure 6-10 I<sup>2</sup>C Write Command Packet Example**

**I<sup>2</sup>C Write Packet Address Phase Bytes**

1 <sup>st</sup> Cycle			
START	7654321	0	ACK/NAK
S	Slave Address 1101_000b	Read/Write Bit 0 = Write	A

**I<sup>2</sup>C Write Packet Command Phase Bytes**

Command Cycle							
76543210	ACK/NAK	76543210	ACK/NAK	76543210	ACK/NAK	76543210	ACK/NAK
Command Byte 0 0000_0011b	A	Command Byte 1 0000_0000b	A	Command Byte 2 0011_1100b	A	Command Byte 3 0011_1110b	A

**I<sup>2</sup>C Write Packet Data Phase Bytes**

Write Cycle								
76543210	ACK/NAK	76543210	ACK/NAK	76543210	ACK/NAK	76543210	ACK/NAK	STOP
Register Byte 3	A	Register Byte 2	A	Register Byte 1	A	Register Byte 0	A	P

### 6.3.2 I<sup>2</sup>C REGISTER READ ACCESS

When the I<sup>2</sup>C Master attempts to read a PI7C9X2G308GP register, two packets are transmitted. The 1<sup>st</sup> packet consists of Address and Command Phase bytes to the Slave. The 2<sup>nd</sup> packet consists of Address and Data Phase bytes.

According to the I<sup>2</sup>C Bus, v2.1, a Read cycle is triggered when the Read/Write bit (bit 0) of the 1<sup>st</sup> cycle is Set. The Command phase reads the requested register content into the internal buffer. When the I<sup>2</sup>C Read access occurs, the internal buffer value is transferred on to the I<sup>2</sup>C Bus, starting from Byte 3 (bits [31: 24]), followed by the subsequent bytes, with Byte 0 (bits [7:0]) being transferred last. If the I<sup>2</sup>C Master requests more than four bytes, the PI7C9X2G308GP re-transmits the same byte sequence, starting from Byte 3 of the internal buffer.

The 1<sup>st</sup> and 2<sup>nd</sup> I<sup>2</sup>C Read packets perform the following functions:

- 1<sup>st</sup> packet - Selects the register to read
- 2<sup>nd</sup> packet - Reads the register (sample 2<sup>nd</sup> packet provided is for a 7-bit PI7C9X2G308GP I<sup>2</sup>C Slave address)

Although two packets are shown for the I<sup>2</sup>C Read, the I<sup>2</sup>C Master can merge the two packets together into a single packet, by not generating the STOP at the end of the first packet (Master does not relinquish the bus) and generating REPEAT START.

Table 6-13 describes each I<sup>2</sup>C Command byte for Read access. In the packet described in Figure 6-11, Command Bytes 0 through 3 for Reads follow the format specified in Table 6-13.

**Table 6-13 I<sup>2</sup>C Command Format for Read Access**

Byte	Bit(s)	Description
1 <sup>st</sup> (0)	7:3	Reserved
	2:0	Command 100b = Read register
2 <sup>nd</sup> (1)	7:4	Reserved
	3:0	Port Select, Bits [4:1] 2 <sup>nd</sup> Command byte, bit [3:0], and 3 <sup>rd</sup> Command byte, bit 7, combine to form a 5-bit Port Select.
3 <sup>rd</sup> (2)	7	Port Select[0] 2 <sup>nd</sup> Command byte, bits [3:0], and 3 <sup>rd</sup> Command byte, bit 7, combine to form a 5-bit Port Select. Port Select[4:0] is used to select Port to access.

Byte	Bit(s)	Description										
		0... Port 0 1... Port 1 2... Port 2										
	6	<b>Reserved</b>										
	5:2	<b>Byte Enable</b>  <table border="0"> <tr> <td><b>Bit</b></td> <td><b>Description</b></td> </tr> <tr> <td>2</td> <td>Byte Enable for Data Byte 4 (PI7C9X2G308GP register bits [7:0])</td> </tr> <tr> <td>3</td> <td>Byte Enable for Data Byte 3 (PI7C9X2G308GP register bits [15:8])</td> </tr> <tr> <td>4</td> <td>Byte Enable for Data Byte 2 (PI7C9X2G308GP register bits [23:16])</td> </tr> <tr> <td>5</td> <td>Byte Enable for Data Byte 1 (PI7C9X2G308GP register bits [31:24])</td> </tr> </table> 0 = Corresponding PI7C9X2G308GP register byte will not be modified 1 = Corresponding PI7C9X2G308GP register byte will be modified	<b>Bit</b>	<b>Description</b>	2	Byte Enable for Data Byte 4 (PI7C9X2G308GP register bits [7:0])	3	Byte Enable for Data Byte 3 (PI7C9X2G308GP register bits [15:8])	4	Byte Enable for Data Byte 2 (PI7C9X2G308GP register bits [23:16])	5	Byte Enable for Data Byte 1 (PI7C9X2G308GP register bits [31:24])
<b>Bit</b>	<b>Description</b>											
2	Byte Enable for Data Byte 4 (PI7C9X2G308GP register bits [7:0])											
3	Byte Enable for Data Byte 3 (PI7C9X2G308GP register bits [15:8])											
4	Byte Enable for Data Byte 2 (PI7C9X2G308GP register bits [23:16])											
5	Byte Enable for Data Byte 1 (PI7C9X2G308GP register bits [31:24])											
	1:0	<b>PI7C9X2G308GP Register Address [11:10]</b>										
4 <sup>th</sup> (3)	7:0	<b>PI7C9X2G308GP Register Address [9:2]</b> Note: Address bits[1:0] are fixed to 0.										

Figure 6-11 I<sup>2</sup>C Read Command Packet

**I<sup>2</sup>C Read Command Packet Address Phase Byte (1<sup>st</sup> Packet)**

1 <sup>st</sup> Cycle			
<b>START</b>	<b>7654321</b>	<b>0</b>	<b>ACK/NAK</b>
S	Slave Address[7:1]	Read/Write Bit 0 = Write	A

**I<sup>2</sup>C Read Command Packet Command Phase Byte (1st Packet)**

Write Cycle							
<b>76543210</b>	<b>ACK/NAK</b>	<b>76543210</b>	<b>ACK/NAK</b>	<b>76543210</b>	<b>ACK/NAK</b>	<b>76543210</b>	<b>ACK/NAK</b>
Command Byte 0	A	Command Byte 1	A	Command Byte 2	A	Command Byte 3	A

**I<sup>2</sup>C Read Data Packet Address Phase Byte (2<sup>nd</sup> Packet)**

1 <sup>st</sup> Cycle			
<b>START</b>	<b>7654321</b>	<b>0</b>	<b>ACK/NAK</b>
S	Slave Address[7:1]	Read/Write Bit 1 = Read	A

**I<sup>2</sup>C Read Data Packet Data Phase Byte (2<sup>nd</sup> Packet)**

Write Cycle								
<b>76543210</b>	<b>ACK/NAK</b>	<b>76543210</b>	<b>ACK/NAK</b>	<b>76543210</b>	<b>ACK/NAK</b>	<b>76543210</b>	<b>ACK/NAK</b>	<b>STOP</b>
Register Byte 3	A	Register Byte 2	A	Register Byte 1	A	Register Byte 0	A	P

The following tables illustrate a sample I2C packet for reading the PI7C9X2G308GP SSID/SSVID register (offset F8h) for Port 0. The default value for SSID/SSVID register is 0000\_0000h.

**Note:** The PI7C9X2G308GP has a default I<sup>2</sup>C Slave address [6:0] value of 68h, with the GPIO[7:5] inputs having a value of 000. The byte sequence on the I<sup>2</sup>C Bus, as listed in the following tables, occurs after the START and before the STOP bits, by which the I<sup>2</sup>C Master frames the transfer.

**Figure 6-12 I<sup>2</sup>C Register Read Access Example**

**I<sup>2</sup>C Register Read Access Example – Address Cycle (1<sup>st</sup> Packet)**

Phase	Value	Description
Address	D0h	Bits [7:1] for PI7C9X2G308GP I <sup>2</sup> C Slave Address (68h) with last bit (bit 0) for Write = 0

**I<sup>2</sup>C Register Read Access Example – Command Cycle (1<sup>st</sup> Packet)**

Byte	Value	Description
0	04h	[7:3] Reserved [2:0] Command , 100b = Read register
1	00h for Port 0	[7:4] Reserved [3:0] Port Select[4:1]
2	3Ch for Port 0	[7] Port Select[0] [6] Reserved [5:2] Byte Enable, All active. [1:0] PI7C9X2G308GP Register Address, Bits [11:10]
3	3Eh	[7:0] PI7C9X2G308GP Register Address, Bits [9:2]

**I<sup>2</sup>C Register Read Access Example – 2<sup>nd</sup> Packet**

Phase	Value	Description
Address	D1h	Bits [7:1] for PI7C9X2G308GP I <sup>2</sup> C Slave Address (68h) with last bit (bit 0) for Read = 1
Read	00h	Byte 3 of Register Read
	00h	Byte 2 of Register Read
	00h	Byte 1 of Register Read
	00h	Byte 0 of Register Read

**Figure 6-13 I<sup>2</sup>C Read Command Packet**

**I<sup>2</sup>C Read Command Packet Address Phase Bytes (1<sup>st</sup> Packet)**

1 <sup>st</sup> Cycle			
START	7654321	0	ACK/NAK
S	Slave Address 1101_000b	Read/Write Bit 0 = Write	A

**I<sup>2</sup>C Read Command Packet Command Phase Bytes (1<sup>st</sup> Packet)**

Command Cycle						
76543210	ACK/NAK	76543210	ACK/NAK	76543210	ACK/NAK	76543210
Command Byte 0 0000_0100b	A	Command Byte 1 0000_0000b	A	Command Byte 2 0011_1100b	A	Command Byte 3 0011_1110b

**I<sup>2</sup>C Read Data Packet Address Phase Bytes (2<sup>nd</sup> Packet)**

1 <sup>st</sup> Cycle			
START	7654321	0	ACK/NAK
S	Slave Address [7:1] 1101_000b	Read/Write Bit 1 = Read	A

**I<sup>2</sup>C Read Data Packet Data Phase Bytes (2<sup>nd</sup> Packet)**

Command Cycle							
76543210	ACK/NAK	76543210	ACK/NAK	76543210	ACK/NAK	76543210	Stop
Register Byte3 0000_0000b	A	Register Byte2 0000_0000b	A	Register Byte1 0000_0000b	A	Register Byte0 0000_0000b	P



## 7 REGISTER DESCRIPTION

### 7.1 REGISTER TYPES

REGISTER TYPE	DEFINITION
HwInt	Hardware Initialization
RO	Read Only
RW	Read / Write
RWC	Read / Write 1 to Clear
RWCS	Sticky – Read Only / Write 1 to Clear
RWS	Sticky – Read / Write

### 7.2 TRANSPARENT MODE CONFIGURATION REGISTERS

When the port of the Switch is set to operate at the transparent mode, it is represented by a logical PCI-to-PCI Bridge that implements type 1 configuration space header. The following table details the allocation of the register fields of the PCI 2.3 compatible type 1 configuration space header.

31 – 24	23 – 16	15 – 8	7 – 0	BYTE OFFSET
Device ID		Vendor ID		00h
Primary Status		Command		04h
Class Code		Revision ID		08h
Reserved	Header Type	Primary Latency Timer	Cache Line Size	0Ch
Reserved				10h – 14h
Secondary Latency Timer	Subordinate Bus Number	Secondary Bus Number	Primary Bus Number	18h
Secondary Status		I/O Limit Address	I/O Base Address	1Ch
Memory Limit Address		Memory Base Address		20h
Prefetchable Memory Limit Address		Prefetchable Memory Base Address		24h
Prefetchable Memory Base Address Upper 32-bit				28h
Prefetchable Memory Limit Address Upper 32-bit				2Ch
I/O Limit Address Upper 16-bit		I/O Base Address Upper 16-bit		30h
Reserved			Capability Pointer	34h
Reserved				38h
Bridge Control		Interrupt Pin	Interrupt Line	3Ch
Power Management Capabilities		Next Item Pointer	Capability ID=01	40h
PM Data	PPB Support Extensions	Power Management Data		44h
Message Control		Next Item Pointer	Capability ID=05	4Ch
Message Address				50h
Message Upper Address				54h
Reserved		Message Data		58h
VPD Register		Next Item Pointer	Capability ID=03	5Ch
VPD Data Register				60h
Length in Bytes (34h)		Next Item Pointer=	Capability ID=09	64h
XPIP_CSR0				68h
XPIP_CSR1				6Ch
ACK Latency Timer		Replay Time-out Counter		70h
PHY Parameter 0		Switch Modes		74h
PHY Parameter 1		XPIP_CSR2		78h
PHY Parameter 2				7Ch
XPIP_CSR3				80h
XPIP_CSR4				84h
XPIP_CSR5				88h
XPIP_CSR7	XPIP_CSR6	Port Misc	TL_CSR	8Ch
PHY Parameter 3				90h
Reserved		PHY TX Margin Parameter		94h
L1PM	Buffer Ctrl	OP Mode		98h
Device specific PME				9Ch

31 – 24	23 – 16	15 – 8	7 – 0	BYTE OFFSET
Reserved		EEPROM status	EPPROM Control	A0h
EEPROM Data		EEPROM Address		A4h
Reserved			DebugOut Control	A8h
DebugOut Data				
Reserved		Next Item Pointer	SSID/SSVID Capability ID=0D	B0h
SSID		SSVID		B4h
GPIO Data and Control				B8h
Reserved				
PCI Express Capabilities Register		Next Item Pointer	Capability ID=10	C0h
Device Capabilities				C4h
Device Status		Device Control		C8h
Link Capabilities				CCh
Link Status		Link Control		D0h
Slot Capabilities				D4h
Slot Status		Slot Control		D8h
Reserved				DCh
Reserved				E0h
Device Capabilities 2				E4h
Device Status 2		Device Control 2		E8h
Link Capabilities 2				ECh
Link Status 2		Link Control 2		F0h
Slot Capabilities 2				F4h
Slot Status 2		Slot Control 2		F8h
Reserved				FCh

Other than the PCI 2.3 compatible configuration space header, the Switch also implements PCI express extended configuration space header, which includes advanced error reporting, virtual channel, and power budgeting capability registers. The following table details the allocation of the register fields of PCI express extended capability space header. The first extended capability always begins at offset 100h with a PCI Express Enhanced Capability header and the rest of capabilities are located at an offset greater than 0FFh relative to the beginning of PCI compatible configuration space.

31 – 24	23 – 16	15 – 8	7 – 0	BYTE OFFSET
Next Capability Offset	Cap. Version	PCI Express Extended Capability ID=0001h		100h
Uncorrectable Error Status Register				104h
Uncorrectable Error Mask Register				108h
Uncorrectable Error Severity Register				10Ch
Correctable Error Status Register				110h
Correctable Error Mask Register				114h
Advanced Error Capabilities and Control Register				118h
Header Log Register				11Ch – 128h
Reserved				12Ch – 13Ch
Next Capability Offset	Cap. Version	PCI Express Extended Capability ID=0002h		140h
Port VC Capability Register 1				144h
VC Arbitration Table Offset=3	Port VC Capability Register 2			148h
Port VC Status Register		Port VC Control Register		14Ch
Port Arbitration Table Offset=4	VC Resource Capability Register (0)			150h
VC Resource Control Register (0)				154h
VC Resource Status Register (0)		Reserved		158h
Port Arbitration Table Offset=6	VC Resource Capability Register (1)			15Ch
VC Resource Control Register (1)				160h
VC Resource Status Register (1)		Reserved		164h
Reserved				168h – 16Ch
VC Arbitration Table with 32 Phases				170h – 17Ch
Port Arbitration Table with 128 Phases for VC0				180h – 1BCh
Port Arbitration Table with 128 Phases for VC1				1C0h – 1FCh
Reserved				200h – 208h

31 – 24		23 – 16		15 – 8		7 – 0		BYTE OFFSET
Next Capability Offset		Cap. Version		PCI Express Extended Capability ID=0004h				20Ch
Reserved				Data Select Register				210h
Data Register								214h
Reserved				Power Budget Capability Register				218h
Reserved								21Ch
Next Capability Offset		Cap version		PCI Express Extended Capability ID=000Dh				220h
ACS Control				ACS Capability				224h
Reserved				Egress Control Vector				228h
Reserved								22Ch
Next Capability Offset		Cap version		PCI Express Extended Capability ID=0018h				230h
Reserved	Max No-Snoop Latency Scale	Max No-Snoop Latency Value	Reserved	Max Snoop Latency Scale	Max Snoop Latency Value			234h
Reserved								238h - 23Ch
Next Capability Offset=000h		Cap version		PCI Express Extended Capability ID=001Eh				240h
L1 PM Substates Capability								244h
L1 PM Substates Control 1								248h
L1 PM Substates Control 2								24Ch
Reserved								250h - 338h
LTSSM CSR								33Ch
MAC CSR1				Hotplug CSR				340h
SMBUS Control								344h
Reserved								348h – 34Ch
Reserved				CPLD Flow Control Enable				350h
X2 CPLD Flow Control Threshold				X1 CPLD Flow Control Threshold				354h
Reserved				X4 CPLD Flow Control Threshold				358h
Reserved								35Ch
Power Saving Disable								360h
LED Display CSR								364h

### 7.2.1 VENDOR ID REGISTER – OFFSET 00h

BIT	FUNCTION	TYPE	DESCRIPTION
15:0	Vendor ID	RO	Identifies Pericom as the vendor of this device. The default value may be changed by auto-loading from EEPROM.  Reset to 12D8h.

### 7.2.2 DEVICE ID REGISTER – OFFSET 00h

BIT	FUNCTION	TYPE	DESCRIPTION
31:16	Device ID	RO	Identifies this device as the PI7C9X2G308GP. The default value may be changed by SMBUS, I2C or auto-loading from EEPROM.  Resets to 2308h.

### 7.2.3 COMMAND REGISTER – OFFSET 04h

BIT	FUNCTION	TYPE	DESCRIPTION
0	I/O Space Enable	RW	0b: Ignores I/O transactions on the primary interface 1b: Enables responses to I/O transactions on the primary interface

BIT	FUNCTION	TYPE	DESCRIPTION
			Resets to 0b.
1	Memory Space Enable	RW	0b: Ignores memory transactions on the primary interface 1b: Enables responses to memory transactions on the primary interface  Reset to 0b.
2	Bus Master Enable	RW	0b: Does not initiate memory or I/O transactions on the upstream port and handles as an Unsupported Request (UR) to memory and I/O transactions on the downstream port. For Non-Posted Requests, a completion with UR completion status must be returned 1b: Enables the Switch Port to forward memory and I/O Read/Write transactions in the upstream direction  Reset to 0b.
3	Special Cycle Enable	RO	Does not apply to PCI Express. Must be hardwired to 0b.
4	Memory Write And Invalidate Enable	RO	Does not apply to PCI Express. Must be hardwired to 0b.
5	VGA Palette Snoop Enable	RO	Does not apply to PCI Express. Must be hardwired to 0b.
6	Parity Error Response Enable	RW	0b: Switch may ignore any parity errors that it detects and continue normal operation 1b: Switch must take its normal action when a parity error is detected  Reset to 0b.
7	Wait Cycle Control	RO	Does not apply to PCI Express. Must be hardwired to 0b.
8	SERR# enable	RW	0b: Disables the reporting of Non-fatal and Fatal errors detected by the Switch to the Root Complex 1b: Enables the Non-fatal and Fatal error reporting to Root Complex  Reset to 0b.
9	Fast Back-to-Back Enable	RO	Does not apply to PCI Express. Must be hardwired to 0b.
10	Interrupt Disable	RW	Controls the ability of a PCI Express device to generate INTx Interrupt Messages. In the Switch, this bit does not affect the forwarding of INTx messages from the downstream ports.  Reset to 0b.
15:11	Reserved	RsvdP	Not Support.

## 7.2.4 PRIMARY STATUS REGISTER – OFFSET 04h

BIT	FUNCTION	TYPE	DESCRIPTION
18:16	Reserved	RsvdP	Not Support.
19	Interrupt Status	RO	Indicates that an INTx Interrupt Message is pending internally to the device. In the Switch, the forwarding of INTx messages from the downstream device of the Switch port is not reflected in this bit. Must be hardwired to 0b.
20	Capabilities List	RO	Set to 1b to enable support for the capability list (offset 34h is the pointer to the data structure).  Reset to 1b.
21	66MHz Capable	RO	Does not apply to PCI Express. Must be hardwired to 0b.
22	Reserved	RsvdP	Not Support.
23	Fast Back-to-Back Capable	RO	Does not apply to PCI Express. Must be hardwired to 0b.
24	Master Data Parity Error	RWC	Set to 1b (by a requester) whenever a Parity error is detected or forwarded on the primary side of the port in a Switch.  If the Parity Error Response Enable bit is cleared, this bit is never set.  Reset to 0b.
26:25	DEVSEL# timing	RO	Does not apply to PCI Express. Must be hardwired to 0b.
27	Signaled Target Abort	RO	Set to 1b (by a completer) whenever completing a request on the primary side using the Completer Abort Completion Status.  Reset to 0b.

BIT	FUNCTION	TYPE	DESCRIPTION
28	Received Target Abort	RO	Set to 1b (by a requestor) whenever receiving a Completion with Completer Abort Completion Status on the primary side.  Reset to 0b.
29	Received Master Abort	RO	Set to 1b (by a requestor) whenever receiving a Completion with Unsupported Request Completion Status on primary side.  Reset to 0b.
30	Signaled System Error	RWC	Set to 1b when the Switch sends an ERR_FATAL or ERR_NONFATAL Message, and the SERR Enable bit in the Command register is 1b.  Reset to 0b.
31	Detected Parity Error	RWC	Set to 1b whenever the primary side of the port in a Switch receives a Poisoned TLP.  Reset to 0b.

### 7.2.5 REVISION ID REGISTER – OFFSET 08h

BIT	FUNCTION	TYPE	DESCRIPTION
7:0	Revision	RO	Indicates revision number of device. Hardwired to 00h.

### 7.2.6 CLASS CODE REGISTER – OFFSET 08h

BIT	FUNCTION	TYPE	DESCRIPTION
15:8	Programming Interface	RO	Read as 00h to indicate no programming interfaces have been defined for PCI-to-PCI Bridges.
23:16	Sub-Class Code	RO	Read as 04h to indicate device is a PCI-to-PCI Bridge.
31:24	Base Class Code	RO	Read as 06h to indicate device is a Bridge device.

### 7.2.7 CACHE LINE REGISTER – OFFSET 0Ch

BIT	FUNCTION	TYPE	DESCRIPTION
7:0	Cache Line Size	RW	The cache line size register is set by the system firmware and the operating system cache line size. This field is implemented by PCI Express devices as a RW field for legacy compatibility, but it has no impact on any PCI Express device functionality.  Reset to 00h.

### 7.2.8 PRIMARY LATENCY TIMER REGISTER – OFFSET 0Ch

BIT	FUNCTION	TYPE	DESCRIPTION
15:8	Primary Latency timer	RO	Does not apply to PCI Express. Must be hardwired to 00h.

### 7.2.9 HEADER TYPE REGISTER – OFFSET 0Ch

BIT	FUNCTION	TYPE	DESCRIPTION
23:16	Header Type	RO	Read as 01h to indicate that the register layout conforms to the standard PCI-to-PCI Bridge layout.

### 7.2.10 PRIMARY BUS NUMBER REGISTER – OFFSET 18h

BIT	FUNCTION	TYPE	DESCRIPTION
7:0	Primary Bus Number	RW	Indicates the number of the PCI bus to which the primary interface is connected. The value is set in software during configuration. Reset to 00h.

### 7.2.11 SECONDARY BUS NUMBER REGISTER – OFFSET 18h

BIT	FUNCTION	TYPE	DESCRIPTION
15:8	Secondary Bus Number	RW	Indicates the number of the PCI bus to which the secondary interface is connected. The value is set in software during configuration. Reset to 00h.

### 7.2.12 SUBORDINATE BUS NUMBER REGISTER – OFFSET 18h

BIT	FUNCTION	TYPE	DESCRIPTION
23:16	Subordinate Bus Number	RW	Indicates the number of the PCI bus with the highest number that is subordinate to the Bridge. The value is set in software during configuration. Reset to 00h.

### 7.2.13 SECONDARY LATENCY TIMER REGISTER – OFFSET 18h

BIT	FUNCTION	TYPE	DESCRIPTION
31:24	Secondary Latency Timer	RO	Does not apply to PCI Express. Must be hardwired to 00h.

### 7.2.14 I/O BASE ADDRESS REGISTER – OFFSET 1Ch

BIT	FUNCTION	TYPE	DESCRIPTION
3:0	32-bit Indicator	RO	Read as 1h to indicate 32-bit I/O addressing.
7:4	I/O Base Address [15:12]	RW	Defines the bottom address of the I/O address range for the Bridge to determine when to forward I/O transactions from one interface to the other. The upper 4 bits correspond to address bits [15:12] and are writable. The lower 12 bits corresponding to address bits [11:0] are assumed to be 0. The upper 16 bits corresponding to address bits [31:16] are defined in the I/O base address upper 16 bits address register. Reset to 0h.

### 7.2.15 I/O LIMIT ADDRESS REGISTER – OFFSET 1Ch

BIT	FUNCTION	TYPE	DESCRIPTION
11:8	32-bit Indicator	RO	Read as 1h to indicate 32-bit I/O addressing.
15:12	I/O Limit Address [15:12]	RW	Defines the top address of the I/O address range for the Bridge to determine when to forward I/O transactions from one interface to the other. The upper 4 bits correspond to address bits [15:12] and are writable. The lower 12 bits corresponding to address bits [11:0] are assumed to be FFFh. The upper 16 bits corresponding to address bits [31:16] are defined in the I/O limit address upper 16 bits address register.

BIT	FUNCTION	TYPE	DESCRIPTION
			Reset to 0h.

### 7.2.16 SECONDARY STATUS REGISTER – OFFSET 1Ch

BIT	FUNCTION	TYPE	DESCRIPTION
20:16	Reserved	RsvdP	Not Support.
21	66MHz Capable	RO	Does not apply to PCI Express. Must be hardwired to 0b.
22	Reserved	RsvdP	Not Support.
23	Fast Back-to-Back Capable	RO	Does not apply to PCI Express. Must be hardwired to 0b.
24	Master Data Parity Error	RWC	Set to 1b (by a requester) whenever a Parity error is detected or forwarded on the secondary side of the port in a Switch.  If the Parity Error Response Enable bit is cleared, this bit is never set.  Reset to 0b.
26:25	DEVSEL_L timing	RO	Does not apply to PCI Express. Must be hardwired to 0b.
27	Signaled Target Abort	RO	Set to 1b (by a completer) whenever completing a request in the secondary side using Completer Abort Completion Status.  Reset to 0b.
28	Received Target Abort	RO	Set to 1b (by a requester) whenever receiving a Completion with Completer Abort Completion Status in the secondary side.  Reset to 0b.
29	Received Master Abort	RO	Set to 1b (by a requester) whenever receiving a Completion with Unsupported Request Completion Status in secondary side.  Reset to 0b.
30	Received System Error	RWC	Set to 1b when the Switch sends an ERR_FATAL or ERR_NONFATAL Message, and the SERR Enable bit in the Bridge Control register is 1.  Reset to 0b.
31	Detected Parity Error	RWC	Set to 1b whenever the secondary side of the port in a Switch receives a Poisoned TLP.  Reset to 0b.

### 7.2.17 MEMORY BASE ADDRESS REGISTER – OFFSET 20h

BIT	FUNCTION	TYPE	DESCRIPTION
3:0	Reserved	RO	Reset to 0h.
15:4	Memory Base Address [31:20]	RW	Defines the bottom address of an address range for the Bridge to determine when to forward memory transactions from one interface to the other. The upper 12 bits correspond to address bits [31:20] and are able to be written to. The lower 20 bits corresponding to address bits [19:0] are assumed to be 0.  Reset to 000h.

### 7.2.18 MEMORY LIMIT ADDRESS REGISTER – OFFSET 20h

BIT	FUNCTION	TYPE	DESCRIPTION
19:16	Reserved	RO	Reset to 0h.
31:20	Memory Limit Address [31:20]	RW	Defines the top address of an address range for the Bridge to determine when to forward memory transactions from one interface to the other. The upper 12 bits correspond to address bits [31:20] and are writable. The lower 20 bits corresponding to address bits [19:0] are assumed to be FFFFh.  Reset to 000h.

### 7.2.19 PREFETCHABLE MEMORY BASE ADDRESS REGISTER – OFFSET 24h

BIT	FUNCTION	TYPE	DESCRIPTION
3:0	64-bit addressing	RO	Read as 1h to indicate 64-bit addressing.
15:4	Prefetchable Memory Base Address [31:20]	RW	Defines the bottom address of an address range for the Bridge to determine when to forward memory read and write transactions from one interface to the other. The upper 12 bits correspond to address bits [31:20] and are writable. The lower 20 bits are assumed to be 0. The memory base register upper 32 bits contain the upper half of the base address.  Reset to 000h.

### 7.2.20 PREFETCHABLE MEMORY LIMIT ADDRESS REGISTER – OFFSET 24h

BIT	FUNCTION	TYPE	DESCRIPTION
19:16	64-bit addressing	RO	Read as 1h to indicate 64-bit addressing.
31:20	Prefetchable Memory Limit Address [31:20]	RW	Defines the top address of an address range for the Bridge to determine when to forward memory read and write transactions from one interface to the other. The upper 12 bits correspond to address bits [31:20] and are writable. The lower 20 bits are assumed to be FFFFh. The memory limit upper 32 bits register contains the upper half of the limit address.  Reset to 000h.

### 7.2.21 PREFETCHABLE MEMORY BASE ADDRESS UPPER 32-BITS REGISTER – OFFSET 28h

BIT	FUNCTION	TYPE	DESCRIPTION
31:0	Prefetchable Memory Base Address, Upper 32-bits [63:32]	RW	Defines the upper 32-bits of a 64-bit bottom address of an address range for the Bridge to determine when to forward memory read and write transactions from one interface to the other.  Reset to 0000_0000h.

### 7.2.22 PREFETCHABLE MEMORY LIMIT ADDRESS UPPER 32-BITS REGISTER – OFFSET 2Ch

BIT	FUNCTION	TYPE	DESCRIPTION
31:0	Prefetchable Memory Limit Address, Upper 32-bits [63:32]	RW	Defines the upper 32-bits of a 64-bit top address of an address range for the Bridge to determine when to forward memory read and write transactions from one interface to the other.  Reset to 0000_0000h.

### 7.2.23 I/O BASE ADDRESS UPPER 16-BITS REGISTER – OFFSET 30h

BIT	FUNCTION	TYPE	DESCRIPTION
15:0	I/O Base Address, Upper 16-bits [31:16]	RW	Defines the upper 16-bits of a 32-bit bottom address of an address range for the Bridge to determine when to forward I/O transactions from one interface to the other.  Reset to 0000h.



### 7.2.24 I/O LIMIT ADDRESS UPPER 16-BITS REGISTER – OFFSET 30h

BIT	FUNCTION	TYPE	DESCRIPTION
31:16	I/O Limit Address, Upper 16-bits [31:16]	RW	Defines the upper 16-bits of a 32-bit top address of an address range for the Bridge to determine when to forward I/O transactions from one interface to the other.  Reset to 0000h.

### 7.2.25 CAPABILITY POINTER REGISTER – OFFSET 34h

BIT	FUNCTION	TYPE	DESCRIPTION
7:0	Capability Pointer	RO	Pointer points to the PCI power management registers (40h).  Reset to 40h.

### 7.2.26 INTERRUPT LINE REGISTER – OFFSET 3Ch

BIT	FUNCTION	TYPE	DESCRIPTION
7:0	Interrupt Line	RW	Reset to 00h.

### 7.2.27 INTERRUPT PIN REGISTER – OFFSET 3Ch

BIT	FUNCTION	TYPE	DESCRIPTION
15:8	Interrupt Pin	RO	The Switch implements INTA virtual wire interrupt signals to represent hot-plug events at downstream ports. The default value on the downstream ports may be changed by SMBUS, I2C or auto-loading from EEPROM.  Reset to 00h.

### 7.2.28 BRIDGE CONTROL REGISTER – OFFSET 3Ch

BIT	FUNCTION	TYPE	DESCRIPTION
16	Parity Error Response	RW	0b: Ignore Poisoned TLPs on the secondary interface 1b: Enable the Poisoned TLPs reporting and detection on the secondary interface  Reset to 0b.
17	S_SERR# enable	RW	0b: Disables the forwarding of EER_COR, ERR_NONFATAL and ERR_FATAL from secondary to primary interface 1b: Enables the forwarding of EER_COR, ERR_NONFATAL and ERR_FATAL from secondary to primary interface  Reset to 0b.
18	ISA Enable	RW	0b: Forwards downstream all I/O addresses in the address range defined by the I/O Base, I/O Base, and Limit registers 1b: Forwards upstream all I/O addresses in the address range defined by the I/O Base and Limit registers that are in the first 64KB of PCI I/O address space (top 768 bytes of each 1KB block)  Reset to 0b.
19	VGA Enable	RW	0b: Ignores access to the VGA memory or IO address range 1b: Forwards transactions targeted at the VGA memory or IO address range  VGA memory range starts from 000A 0000h to 000B FFFFh VGA IO addresses are in the first 64KB of IO address space.

BIT	FUNCTION	TYPE	DESCRIPTION
			AD [9:0] is in the ranges 3B0 to 3BBh and 3C0h to 3DFh. Reset to 0b.
20	VGA 16-bit decode	RW	0b: Executes 10-bit address decoding on VGA I/O accesses 1b: Executes 16-bit address decoding on VGA I/O accesses Reset to 0b.
21	Master Abort Mode	RO	Does not apply to PCI Express. Must be hardwired to 0b.
22	Secondary Bus Reset	RW	0b: Does not trigger a hot reset on the corresponding PCI Express Port 1b: Triggers a hot reset on the corresponding PCI Express Port At the downstream port, it asserts PORT_RST# to the attached downstream device. At the upstream port, it asserts the PORT_RST# at all the downstream ports. Reset to 0b.
23	Fast Back-to-Back Enable	RO	Does not apply to PCI Express. Must be hardwired to 0b.
24	Primary Master Timeout	RO	Does not apply to PCI Express. Must be hardwired to 0b.
25	Secondary Master Timeout	RO	Does not apply to PCI Express. Must be hardwired to 0b.
26	Master Timeout Status	RO	Does not apply to PCI Express. Must be hardwired to 0b.
27	Discard Timer SERR# enable	RO	Does not apply to PCI Express. Must be hardwired to 0b.
31:28	Reserved	RsvdP	Not Support.

## 7.2.29 POWER MANAGEMENT CAPABILITY REGISTER – OFFSET 40h

BIT	FUNCTION	TYPE	DESCRIPTION
7:0	Enhanced Capabilities ID	RO	Read as 01h to indicate that these are power management enhanced capability registers.
15:8	Next Item Pointer	RO	The pointer points to the Vital Protocol Data (VPD) capability register / Message capability register. Reset to 5Ch (Upstream Port). Reset to 4Ch (Downstream Ports).
18:16	Power Management Revision	RO	Read as 011b to indicate the device is compliant to Revision 1.2 of <i>PCI Power Management Interface Specifications</i> .
19	PME# Clock	RO	Does not apply to PCI Express. Must be hardwired to 0b.
20	Reserved	RsvdP	Not Support.
21	Device Specific Initialization	RO	Read as 0b to indicate Switch does not have device specific initialization requirements. The default value may be changed by SMBUS, I2C or auto-loading from EEPROM.
24:22	AUX Current	RO	Reset as 111b to indicate the Switch needs 375 mA in D3 state. The default value may be changed by SMBUS, I2C or auto-loading from EEPROM.
25	D1 Power State Support	RO	Read as 1b to indicate Switch supports the D1 power management state. The default value may be changed by SMBUS, I2C or auto-loading from EEPROM.
26	D2 Power State Support	RO	Read as 1b to indicate Switch supports the D2 power management state. The default value may be changed by SMBUS, I2C or auto-loading from EEPROM.
31:27	PME# Support	RO	Read as 1_111b to indicate Switch supports the forwarding of PME# message in all power states. The default value may be changed by SMBUS, I2C or auto-loading from EEPROM.

## 7.2.30 POWER MANAGEMENT DATA REGISTER – OFFSET 44h

BIT	FUNCTION	TYPE	DESCRIPTION
1:0	Power State	RW	Indicates the current power state of the Switch. Writing a value of D0 when the previous state was D3 cause a hot reset without asserting DWN_RST L.

BIT	FUNCTION	TYPE	DESCRIPTION
			00b: D0 state 01b: D1 state 10b: D2 state 11b: D3 hot state  Reset to 00b.
2	Reserved	RsvdP	Not Support.
3	No_Soft_Reset	RO	When set, this bit indicates that device transitioning from D3hot to D0 does not perform an internal reset. When clear, an internal reset is performed when power state transits from D3hot to D0. The default value may be changed by SMBUS, I2C or auto-loading from EEPROM.  Reset to 1b.
7:4	Reserved	RsvdP	Not Support.
8	PME# Enable	RW	When asserted, the Switch will generate the PME# message. Reset to 1'b0.
12:9	Data Select	RW	Select data registers.  Reset to 0h.
14:13	Data Scale	RO	Reset to 00b.
15	PME Status	RO	Read as 0b as the PME# message is not implemented.

### 7.2.31 PPB SUPPORT EXTENSIONS – OFFSET 44h

BIT	FUNCTION	TYPE	DESCRIPTION
21:16	Reserved	RO	Reset to 00 0000b.
22	B2_B3 Support for D3 <sub>HOT</sub>	RO	Does not apply to PCI Express. Must be hardwired to 0b.
23	Bus Power / Clock Control Enable	RO	Does not apply to PCI Express. Must be hardwired to 0b.

### 7.2.32 DATA REGISTER – OFFSET 44h

BIT	FUNCTION	TYPE	DESCRIPTION
31:24	Data Register	RO	Data Register. The default value may be changed by SMBUS, I2C or auto-loading from EEPROM.  Reset to 00h.

### 7.2.33 MSI CAPABILITY REGISTER – OFFSET 4Ch (Downstream Port Only)

BIT	FUNCTION	TYPE	DESCRIPTION
7:0	Enhanced Capabilities ID	RO	Read as 05h to indicate that this is message signal interrupt capability register.
15:8	Next Item Pointer	RO	Pointer points to the Vendor specific capability register.  Reset to 64h.

### 7.2.34 MESSAGE CONTROL REGISTER – OFFSET 4Ch (Downstream Port Only)

BIT	FUNCTION	TYPE	DESCRIPTION
16	MSI Enable	RW	0b: The function is prohibited from using MSI to request service 1b: The function is permitted to use MSI to request service and is prohibited from using its INTx # pin  Reset to 0b.

BIT	FUNCTION	TYPE	DESCRIPTION
19:17	Multiple Message Capable	RO	Read as 000b.
22:20	Multiple Message Enable	RW	Reset to 000b.
23	64-bit address capable	RO	0b: The function is not capable of generating a 64-bit message address 1b: The function is capable of generating a 64-bit message address Reset to 1b.
31:24	Reserved	RsvdP	Not Support.

### 7.2.35 MESSAGE ADDRESS REGISTER – OFFSET 50h (Downstream Port Only)

BIT	FUNCTION	TYPE	DESCRIPTION
1:0	Reserved	RsvdP	Not Support.
31:2	Message Address	RW	If the message enable bit is set, the contents of this register specify the DWORD aligned address for MSI memory write transaction. Reset to 0000_0000h.

### 7.2.36 MESSAGE UPPER ADDRESS REGISTER – OFFSET 54h (Downstream Port Only)

BIT	FUNCTION	TYPE	DESCRIPTION
31:0	Message Upper Address	RW	This register is only effective if the device supports a 64-bit message address is set. Reset to 0000_0000h.

### 7.2.37 MESSAGE DATA REGISTER – OFFSET 58h (Downstream Port Only)

BIT	FUNCTION	TYPE	DESCRIPTION
15:0	Message Data	RW	Reset to 0000h.
31:16	Reserved	RsvdP	Not Support.

### 7.2.38 VPD CAPABILITY ID REGISTER – OFFSET 5Ch (Upstream Port Only)

BIT	FUNCTION	TYPE	DESCRIPTION
7:0	Enhanced Capabilities ID	RO	Read as 03h to indicate that these are VPD enhanced capability registers.
15:8	Next Item Pointer	RO	Pointer points to the Vendor specific capability register. Reset to 64h.

### 7.2.39 VPD REGISTER – OFFSET 5Ch (Upstream Port Only)

BIT	FUNCTION	TYPE	DESCRIPTION
17:16	Reserved	RsvdP	Not Support.
23:18	VPD Address	RW	Contains DWORD address that is used to generate read or write cycle to the VPD table stored in EEPROM. Reset to 00_0000b.
29:24	Reserved	RsvdP	Not Support.
30	VPD Write Enable	RW	Enable the write operation.

BIT	FUNCTION	TYPE	DESCRIPTION
			Reset to 0b.
31	VPD operation	RW	0b: Performs VPD read command to VPD table at the location as specified in VPD address. This bit is kept '0' and then set to '1' automatically after EEPROM cycle is finished 1b: Performs VPD write command to VPD table at the location as specified in VPD address. This bit is kept '1' and then set to '0' automatically after EEPROM cycle is finished. Reset to 0b.

#### 7.2.40 VPD DATA REGISTER – OFFSET 60h (Upstream Port Only)

BIT	FUNCTION	TYPE	DESCRIPTION
31:0	VPD Data	RW	When read, it returns the last data read from VPD table at the location as specified in VPD Address. When written, it places the current data into VPD table at the location as specified in VPD Address. Reset to 0000_0000h.

#### 7.2.41 VENDOR SPECIFIC CAPABILITY REGISTER – OFFSET 64h

BIT	FUNCTION	TYPE	DESCRIPTION
7:0	Enhanced Capabilities ID	RO	Read as 09h to indicate that these are vendor specific capability registers.
15:8	Next Item Pointer	RO	Pointer points to the SSID/SSVID capability register. Reset to B0h.
31:16	Length Information	RO	The length field provides the information for number of bytes in the capability structure (including the ID and Next pointer bytes). Reset to 34h.

#### 7.2.42 XPIP\_CSR0 – OFFSET 68h (Test Purpose Only)

BIT	FUNCTION	TYPE	DESCRIPTION
31:0	XPIP_CSR0	RW	The default value for bit [14:13] may be changed by auto-loading from EEPROM. Bit[1]: Enable to change LTSSM Role 1b: enable to change LTSSM role 0b: disable to change LTSSM role Bit[2]: Disable hot reset (Upstream Port Only) 1b: do not fire hot reset to downstream ports if upstream port link is down 0b: do fire hot reset to downstream ports if upstream port link is down Bit[3]: LTSSM CFG_DN_Port Select 1b: set LTSSM role to packet switch downstream port 0b: set LTSSM role to packet switch upstream port Reset to 0400_1060h.

### 7.2.43 XPIP\_CSR1 – OFFSET 6Ch (Test Purpose Only)

BIT	FUNCTION	TYPE	DESCRIPTION
31:0	XPIP_CSR1	RW	Reset to 0400_0800h.

### 7.2.44 REPLAY TIME-OUT COUNTER – OFFSET 70h

BIT	FUNCTION	TYPE	DESCRIPTION
11:0	User Replay Timer	RW	A 12-bit register contains a user-defined value. The default value may be changed by SMBUS, I2C or auto-loading from EEPROM. Reset to 000h.
12	Enable User Replay Timer	RW	When asserted, the user-defined replay time-out value is employed. The default value may be changed by SMBUS, I2C or auto-loading from EEPROM. Reset to 0b.
13	Power Management Capability Disable	RO	The default value may be changed by SMBUS, I2C or auto-loading from EEPROM. Reset to 0b.
14	MSI Capability Disable	RO	The default value may be changed by SMBUS, I2C or auto-loading from EEPROM. Reset to 0b.
15	Reserved	RsvdP	Not Support.

### 7.2.45 ACKNOWLEDGE LATENCY TIMER – OFFSET 70h

BIT	FUNCTION	TYPE	DESCRIPTION
29:16	User ACK Latency Timer	RW	A 14-bit register contains a user-defined value. The default value may be changed by SMBUS, I2C or auto-loading from EEPROM. Reset to 0000h.
30	Enable User ACK Latency	RW	When asserted, the user-defined ACK latency value is employed. The default value may be changed by SMBUS, I2C or auto-loading from EEPROM. Reset to 0b.
31	VGA Decode Enable	RO	Enable the VGA range decode. The default value may be changed by SMBUS, I2C or auto-loading from EEPROM. Reset to 1b.

### 7.2.46 SWITCH OPERATION MODE – OFFSET 74h (Upstream Port Only)

BIT	FUNCTION	TYPE	DESCRIPTION
0	Store-Forward	RW	When set, a store-forward mode is used. Otherwise, the chip is working under cut-through mode. The default value may be changed by SMBUS, I2C or auto-loading from EEPROM. Reset to 0b.

BIT	FUNCTION	TYPE	DESCRIPTION
2:1	Cut-through Threshold	RW	<p>Cut-through Threshold. When forwarding a packet from low-speed port to high-speed mode, the chip provides the capability to adjust the forwarding threshold. The default value may be changed by SMBUS, I2C or auto-loading from EEPROM.</p> <p>00b: the threshold is set at the middle of forwarding packet            01b: the threshold is set ahead 1-cycle of middle point            10b: the threshold is set ahead 2-cycle of middle point.            11b: the threshold is set ahead 3-cycle of middle point.</p> <p>Reset to 01b.</p>
3	Port Arbitration Mode	RW	<p>When set, the round-robin arbitration will stay in the arbitrated port even if the credit is not enough but request is pending.            When clear, the round-robin arbitration will always go to the requesting port, which the outgoing credit is enough for the packet queued in the port.            The default value may be changed by SMBUS, I2C or auto-loading from EEPROM.</p> <p>Reset to 0b.</p>
4	Credit Update Mode	RW	<p>When set, the frequency of releasing new credit to the link partner will be all types per update.            When clear, the frequency of releasing new credit to the link partner will be type oriented per update.</p> <p>The default value may be changed by SMBUS, I2C or auto-loading from EEPROM.</p> <p>Reset to 0b.</p>
5	Ordering on Different Egress Port Mode	RW	<p>When set, there has ordering rule on packets for different egress port. The default value may be changed by SMBUS, I2C or auto-loading from EEPROM.</p> <p>Reset to 0b.</p>
6	Ordering on Different Tag of Completion Mode	RW	<p>When set, there has ordering rule between completion packet with different tag. The default value may be changed by SMBUS, I2C or auto-loading from EEPROM.</p> <p>Reset to 0b.</p>
7	NonPost TLP Store-Forward	RO	<p>When set, for Non-port TLP store-forward mode is used. Otherwise, Non-post TLP is working under cut-through mode. The default value may be changed by SMBUS, I2C or auto-loading from EEPROM.</p> <p>Reset to 0b.</p>
13:8	Power Management Control Parameter	RW	<p>The default value may be changed by SMBUS, I2C or auto-loading from EEPROM.</p> <p>Reset to 00_0001b.</p>
14	RX Polarity Inversion Disable	RO	<p>The default value may be changed by SMBUS, I2C or auto-loading from EEPROM.</p> <p>Reset to 0b.</p>
15	Compliance Pattern Parity Control Disable	RO	<p>The default value may be changed by SMBUS, I2C or auto-loading from EEPROM.</p> <p>Reset to 0b.</p>
20:16	C_DRV_LVL_3P5_NOM	RO	<p>The default value may be changed by SMBUS, I2C or auto-loading from EEPROM.</p> <p>Reset to 1_0011b.</p>
25:21	C_DRV_LVL_6P0_NOM	RO	<p>The default value may be changed by SMBUS, I2C or auto-loading from EEPROM.</p> <p>Reset to 1_0011b.</p>
30:26	C_DRV_LVL_HALF_NOM	RO	<p>The default value may be changed by SMBUS, I2C or auto-loading from EEPROM.</p> <p>Reset to 0_0010b.</p>
31	Reserved	RsvdP	Not Support.

### 7.2.47 SWITCH OPERATION MODE – OFFSET 74h (Downstream Port Only)

BIT	FUNCTION	TYPE	DESCRIPTION
7:0	Reserved	RsvdP	Not Support.
13:8	Power Management Control Parameter	RW	The default value may be changed by SMBUS, I2C or auto-loading from EEPROM. Reset to 00_0001b.
14	RX Polarity Inversion Disable	RO	The default value may be changed by SMBUS, I2C or auto-loading from EEPROM. Reset to 0b.
15:31	Reserved	RsvdP	Not Support.

### 7.2.48 XPIP\_CSR2 – OFFSET 78h

BIT	FUNCTION	TYPE	DESCRIPTION
7:0	FTS Number	RO	The default value may be changed by SMBUS, I2C or auto-loading from EEPROM. Reset to 80h.
9:8	Scrambler Control	RO	The default value may be changed by SMBUS, I2C or auto-loading from EEPROM. Reset to 00b.
10	L0s	RO	The default value may be changed by SMBUS, I2C or auto-loading from EEPROM. Reset to 0b.
11	Compliance to Detect	RO	The default value may be changed by SMBUS, I2C or auto-loading from EEPROM. Reset to 0b.
13:12	Change_Speed_Sel	RO	The default value may be changed by SMBUS, I2C or auto-loading from EEPROM. Reset to 00b.
14	Change_Speed_En	RO	The default value may be changed by SMBUS, I2C or auto-loading from EEPROM. Reset to 0b.
15	Reserved	RsvdP	Not Support.

### 7.2.49 PHY PARAMETER 1 – OFFSET 78h (Upstream Port Only)

BIT	FUNCTION	TYPE	DESCRIPTION
20:16	C_EMP_POST_GEN1_3P5_NOM	RO	The default value may be changed by SMBUS, I2C or auto-loading from EEPROM. Reset to 1_0101b.
25:21	C_EMP_POST_GEN2_3P5_NOM	RO	The default value may be changed by SMBUS, I2C or auto-loading from EEPROM. Reset to 1_0101b.
30:26	C_EMP_POST_GEN2_6P0_NOM	RO	The default value may be changed by SMBUS, I2C or auto-loading from EEPROM. Reset to 1_1101b.
31	Reserved	RsvdP	Not Support.



## 7.2.50 PHY PARAMETER 2 – OFFSET 7Ch

BIT	FUNCTION	TYPE	DESCRIPTION
3:0	C_TX_PHY_LATENACY	RO	The default value may be changed by SMBUS, I2C or auto-loading from EEPROM. It is set by Upstream Port Only. Reset to 0111b.
6:4	C_REC_DETEC_USEC	RO	The default value may be changed by SMBUS, I2C or auto-loading from EEPROM. It is set by Upstream Port Only. Reset to 010b.
7	Reserved	RsvdP	Not Support.
8	P_CDR_FREQLOOP_EN	RO	The default value may be changed by SMBUS, I2C or auto-loading from EEPROM. Reset to 1b.
10:9	P_CDR_THRESHOLD	RO	The default value may be changed by SMBUS, I2C or auto-loading from EEPROM. Reset to 10b.
12:11	P_CDR_FREQLOOP_GAIN	RO	The default value may be changed by SMBUS, I2C or auto-loading from EEPROM. Reset to 11b.
15:13	Reserved	RsvdP	Not Support.
16	P_DRV_LVL_MGN_DELATA_EN	RO	The default value may be changed by SMBUS, I2C or auto-loading from EEPROM. Reset to 0b.
17	P_DRV_LVL_NOM_DELATA_EN	RO	The default value may be changed by SMBUS, I2C or auto-loading from EEPROM. Reset to 0b.
18	P_EMP_POST_MGN_DELATA_EN	RO	The default value may be changed by SMBUS, I2C or auto-loading from EEPROM. Reset to 0b.
19	P_EMP_POST_NOM_DELATA_EN	RO	The default value may be changed by SMBUS, I2C or auto-loading from EEPROM. Reset to 0b.
21:20	P_RX_SIGDET_LVL	RO	The default value may be changed by SMBUS, I2C or auto-loading from EEPROM. Reset to 01b.
25:22	P_RX_EQ_1	RO	The default value may be changed by SMBUS, I2C or auto-loading from EEPROM. Reset to 0110b.
29:26	P_RX_EQ_2	RO	The default value may be changed by SMBUS, I2C or auto-loading from EEPROM. Reset to 1000b.
30	P_TXSWING	RO	The default value may be changed by SMBUS, I2C or auto-loading from EEPROM. Reset to 0b.
31	Reserved	RsvdP	Not Support.

### 7.2.51 XPIP\_CSR3 – OFFSET 80h

BIT	FUNCTION	TYPE	DESCRIPTION
31:0	XPIP_CSR3	RW	The default value may be changed by SMBUS, I2C or auto-loading from EEPROM. Reset to 000F_0000h.

### 7.2.52 XPIP\_CSR4 – OFFSET 84h (Upstream Port Only)

BIT	FUNCTION	TYPE	DESCRIPTION
31:0	XPIP_CSR4	RO	The default value may be changed by SMBUS, I2C or auto-loading from EEPROM. Reset to 0000_0000h.

### 7.2.53 XPIP\_CSR5 – OFFSET 88h

BIT	FUNCTION	TYPE	DESCRIPTION
29:0	XPIP_CSR5[29:0]	RO	The default value may be changed by SMBUS, I2C or auto-loading from EEPROM. It is set by Upstream Port Only. Bit[11]: UP_CFG_Reset Select 0b: cfg data will be reset upon the link down of upstream port 1b: cfg data is not affected when link down of upstream port Reset to 3308_3333h.
30	DO_CHG_DATA_RATE_CTRL	RW	The default value may be changed by SMBUS, I2C or auto-loading from EEPROM. Reset to 1b (Upstream Port). Reset to 0b (Downstream Ports).
31	Gen1_Cap_Only	RW	The default value may be changed by SMBUS, I2C or auto-loading from EEPROM. Reset to 0b.

### 7.2.54 TL\_CSR – OFFSET 8Ch

BIT	FUNCTION	TYPE	DESCRIPTION
0	TX_SOF_FORM	RO	The default value may be changed by SMBUS, I2C or auto-loading from EEPROM. It is set by Upstream Port Only. Reset to 0b.
1	PM Data Select Register R/W Capability	RO	The default value may be changed by SMBUS, I2C or auto-loading from EEPROM. It is set by Upstream Port Only. Reset to 0b.
2	ARBITER_ABORT_SEL	RO	The default value may be changed by SMBUS, I2C or auto-loading from EEPROM. It is set by Upstream Port Only. Reset to 1b.
3	4K Boundary Check Enable	RO	The default value may be changed by SMBUS, I2C or auto-loading from EEPROM. It is set by Upstream Port Only. Reset to 0b.
4	FIFOERR_FIX_SEL	RO	Reset to 1b.

BIT	FUNCTION	TYPE	DESCRIPTION
5	MW Overpass Disable	RW	The default value may be changed by SMBUS, I2C or auto-loading from EEPROM. It is set by Upstream Port Only.  Reset to 0b.
6	Ordering Frozen Disable	RW	Disable the RO ordering rule. The default value may be changed by auto-loading from EEPROM. It is set by Upstream Port Only.  Reset to 0b.
7	GNT_FAIL2IDLE	RO	The default value may be changed by SMBUS, I2C or auto-loading from EEPROM. It is set by Upstream Port Only.  Reset to 1b.
8:9	DO_CHG_DATA_CNT_SEL	RO	The trying number for doing change data rate. The default value may be changed by SMBUS, I2C or auto-loading from EEPROM.  Reset to 00b.
10	Port Disable	RO	Disable this port. The default value may be changed by SMBUS, I2C or auto-loading from EEPROM.  Reset to 0b.
11	Reset Select	RO	Reset select (upstream port only). The default value may be changed by SMBUS, I2C or auto-loading from EEPROM.  Reset to 1b.
12	ARB_VCFLG_SEL	RO	The default value may be changed by SMBUS, I2C or auto-loading from EEPROM. It is set by Upstream Port Only.  Reset to 1b.
15:13	Reserved	RsvdP	Not Support.
23:16	XPIP_CSR6[7:0]	RO	XPIP_CSR6 Value. The default value may be changed by SMBUS, I2C or auto-loading from EEPROM.  Bit[0]: Disable phy error retrain 1b: disable phy error retrain function 0b: enable phy error retrain function  Reset to 79h.
25:24	REV_TS_CTR	RO	The default value may be changed by SMBUS, I2C or auto-loading from EEPROM.  Reset to 00b.
29:26	MAC Control Parameter	RO	The default value may be changed by SMBUS, I2C or auto-loading from EEPROM. It is set by Upstream Port Only.  Reset to 0h.
30	Reserved	RsvdP	Not Support.
31	P35_GEN2_MODE	RO	The default value may be changed by SMBUS, I2C or auto-loading from EEPROM.  Reset to 0b.

### 7.2.55 PHY PARAMETER 3 – OFFSET 90h

BIT	FUNCTION	TYPE	DESCRIPTION
6:0	PHY Parameter 3 (Per Lane)	RO	PHY's Lane mode. The default value may be changed by SMBUS, I2C or auto-loading from EEPROM.  Reset to 00h.
14:7	Reserved	RsvdP	Not Support.
31:15	PHY Parameter 3 (Global)	RO	PHY's delta value setting. The default value may be changed by SMBUS, I2C or auto-loading from EEPROM. It is set by Upstream Port Only.  Reset to 0_0001h.

### 7.2.56 PHY PARAMETER 4 - OFFSET 94h (Upstream Port Only)

BIT	FUNCTION	TYPE	DESCRIPTION
15:0	PHY TX Margin Parameter	RO	The default value may be changed by SMBUS, I2C or auto-loading from EEPROM. Reset to 116Bh.
31:16	Reserved	RsvdP	Not Support.

### 7.2.57 OPERATION MODE – OFFSET 98h

BIT	FUNCTION	TYPE	DESCRIPTION
15:0	Operation Mode	RO	Bit[0]: SROM_BYPASS Bit[1]: IDDQB Bit[2]: FAST_MODE Bit[3]: DEBUG_MODE Bit[4]: PHY_MODE Bit[7:5]: PKG_SEL[2:0] Bit[8]: SCAN_MODE Bit[15:9]: Reserved  Reset to 0122h.
23:16	Clock Buffer Control	RO	For reference clock buffer control. The default value may be changed by SMBUS, I2C or auto-loading from EEPROM. It is set by Upstream Port Only.  Bit[23]: Reset to the status of CLKBUF_PD strapped pin. Bit[22:16]: Reset to 1Fh.  Bit[23]: enable or disable reference clock outputs 0b: enable reference clock outputs 1b: disable reference clock outputs Bit[22:16]: enable or disable REFCLKO_P/N[7:1] 0b: disable 1b: enable
27:24	L1PM Option	RO	The default value may be changed by SMBUS, I2C or auto-loading from EEPROM. Reset to 0h.
31:28	Reserved	RsvdP	Not Support.

### 7.2.58 DEVICE SPECIFIC POWER MANAGEMENT EVENT– OFFSET 9Ch (Downstream Port Only)

BIT	FUNCTION	TYPE	DESCRIPTION
0	Device Specific PME Capability	RO	1b indicate enable device specific PME. The default value may be changed by SMBUS, I2C or auto-loading from EEPROM. Reset to 1b.
1	PME Turnoff Message Request	R/W	Request to send PME turnoff message. Reset to 0b.
2	Port Power	R/W	Control GPIO[4:0] pins when Device Specific PME Capability is enabled. Downstream port 1 controls GPIO[0], Downstream port 2 controls GPIO[1], ... and so on. Reset to 1b.
3	Port Reset	R/W	This bit when reset asserts an active low reset signal to the attached device. When set, the reset signal is de-asserted. Reset to 1b.
15:4	Reserved	RsvdP	Not Support.

BIT	FUNCTION	TYPE	DESCRIPTION
17:16	Link Status	RO	These two bits represent the link status of device connected to the downstream port.  00b: L0 01b: L0s 10b: L1 11b: L2/L3  Reset to 00b.
31:18	Reserved	RsvdP	Not Support.

### 7.2.59 EEPROM CONTROL REGISTER – OFFSET A0h (Upstream Port Only)

BIT	FUNCTION	TYPE	DESCRIPTION
0	EEPROM Start	RW	Starts the EEPROM read or write cycle.  Reset to 0b.
3:1	EEPROM Command	RW	Sends the command to the EEPROM.  001b: write STATUS register 010b: EEPROM write 011b: EEPROM read 100b: disable write operation 101b: read STATUS register 110b: enable the write operation  Reset to 000b.
4	EEPROM Autoload Status	RO	0b: EEPROM autoload was unsuccessful or is disabled 1b: EEPROM autoload occurred successfully after PREST. Configuration registers were loaded with values stored in the EEPROM  Reset to 0b.
5	EEPROM Autoload Disable	RW	0b: EEPROM autoload enabled 1b: EEPROM autoload disabled  Reset to 1b.
7:6	EEPROM Clock Rate	RW	Determines the frequency of the EEPROM clock, which is derived from the primary clock.  00b: Reserved 01b: PEXCLK / 64 (PEXCLK is 250MHz) 10b: Reserved 11b: Test Mode  Reset to 01b.
8	EEPROM Status[0]: Write In Process	RO	Indicate whether the eeprom is busy with write a operation.  Reset to 0b.
9	EEPROM Status[1]: Write Enable Latch	RO	Indicate the status of the write enable latch.  Reset to 0b.
10	EEPROM Status[2]: Block Protection 0	R/W	Indicate the block is currently write protected.  Reset to 0b.
11	EEPROM Status[3]: Block Protection 1	R/W	Indicate the block is currently write protected.  Reset to 0b.
14:12	EEPROM Status[6:4]:	RO	Reset to 000b.
15	EEPROM Status[7] Write Protect Enable	R/W	Write enable Protect bit.  Reset to 0b.

### 7.2.60 EEPROM ADDRESS REGISTER – OFFSET A4h (Upstream Port Only)

BIT	FUNCTION	TYPE	DESCRIPTION
15:0	EEPROM Address	RW	Contains the EEPROM address. Reset to 0000h.

### 7.2.61 EEPROM DATA REGISTER – OFFSET A4h (Upstream Port Only)

BIT	FUNCTION	TYPE	DESCRIPTION
31:16	EEPROM Data	RW	Contains the EEPROM data. Reset to 0000h.

### 7.2.62 DEBUGOUT CONTROL REGISTER – OFFSET A8h (Upstream Port Only)

BIT	FUNCTION	TYPE	DESCRIPTION
4:0	Debug Mode Select	RW	Debug mode select. Reset to 0 0000b.
7:5	Debug Port Select	RW	Debug port select. Reset to 000b.
8	Debug Output Start	RW	Start to select debug output data. Reset to 0b.
23:9	Reserved	RsvdP	Support.
31:24	LED Debug	WO	Reset to 00h.

### 7.2.63 DEBUGOUT DATA REGISTER – OFFSET ACh (Upstream Port Only)

BIT	FUNCTION	TYPE	DESCRIPTION
31:0	Debug Output Data	RO	Contains the debug output data.  When Debug Mode Select is set to 0Ch (A8h.bit[4:0]), this register will show LTSSM state machine.  bit[0]=1... the port is in Detect state bit[1]=1... the port is in Polling state bit[2]=1... the port is in Config state bit[3]=1... the port is in L0 state (link up) bit[4]=1... the port is in L0s state bit[5]=1... the port is in L1 state bit[6]=1... the port is in L2 state bit[7]=1... the port is in Disabled state bit[8]=1... the port is in Hot_Reset state bit[9]=1... the port is in Loopback state bit[10]=1... the port is in Recovery state  Reset to 0000 0000h.

### 7.2.64 SSID/SSVID CAPABILITY REGISTER – OFFSET B0h

BIT	FUNCTION	TYPE	DESCRIPTION
7:0	SSID/SSVID Capabilities ID	RO	Read as 0Dh to indicate that these are SSID/SSVID capability registers.

BIT	FUNCTION	TYPE	DESCRIPTION
15:8	Next Item Pointer	RO	Pointer points to the PCI Express capability register. Reset to C0h.

### 7.2.65 SUBSYSTEM VENDOR ID REGISTER – OFFSET B4h

BIT	FUNCTION	TYPE	DESCRIPTION
15:0	SSVID	RO	It indicates the sub-system vendor id. The default value may be changed by SMBUS, I2C or auto-loading from EEPROM. Reset to 0000h.

### 7.2.66 SUBSYSTEM ID REGISTER – OFFSET B4h

BIT	FUNCTION	TYPE	DESCRIPTION
31:16	SSID	RO	It indicates the sub-system device id. The default value may be changed by SMBUS, I2C or auto-loading from EEPROM. Reset to 0000h.

### 7.2.67 GPIO CONTROL REGISTER – OFFSET B8h (Upstream Port Only)

BIT	FUNCTION	TYPE	DESCRIPTION
0	GPIO [0] Input	HwInt RO	State of GPIO [0] pin. Reset to 1b.
1	GPIO [0] Output Enable	RW	0b: GPIO [0] is an input pin 1b: GPIO [0] is an output pin Reset to 0b.
2	GPIO [0] Output Register	RW	Value of this bit will be output to GPIO [0] pin if GPIO [0] is configured as an output pin. This register is valid when Device Specific PME Capability of downstream port 1 is disabled. Reset to 0b
3	Reserved	RsvdP	Not Support.
4	GPIO [1] Input	HwInt RO	State of GPIO [1] pin. Reset to 1b.
5	GPIO [1] Output Enable	RW	0b: GPIO [1] is an input pin 1b: GPIO [1] is an output pin Reset to 0b.
6	GPIO [1] Output Register	RW	Value of this bit will be output to GPIO [1] pin if GPIO [1] is configured as an output pin. This register is valid when Device Specific PME Capability of downstream port 2 is disabled. Reset to 0b.
7	Reserved	RsvdP	Not Support.
8	GPIO [2] Input	HwInt RO	State of GPIO [2] pin. Reset to 1b.

BIT	FUNCTION	TYPE	DESCRIPTION
9	GPIO [2] Output Enable	RW	0b: GPIO [2] is an input pin 1b: GPIO [2] is an output pin  Reset to 0b.
10	GPIO [2] Output Register	RW	Value of this bit will be output to GPIO [2] pin if GPIO [2] is configured as an output pin.  Reset to 0b.
11	Reserved	RsvdP	Not Support.
12	GPIO [3] Input	HwInit RO	State of GPIO [3] pin.  Reset to 1b.
13	GPIO [3] Output Enable	RW	0b: GPIO [3] is an input pin 1b: GPIO [3] is an output pin  Reset to 0b.
14	GPIO [3] Output Register	RW	Value of this bit will be output to GPIO [3] pin if GPIO [3] is configured as an output pin.  Reset to 0b.
15	Reserved	RsvdP	Not Support.
16	GPIO [4] Input	HwInt RO	State of GPIO [4] pin.  Reset to 1b.
17	GPIO [4] Output Enable	RW	0b: GPIO [4] is an input pin 1b: GPIO [4] is an output pin  Reset to 0b.
18	GPIO [4] Output Register	RW	Value of this bit will be output to GPIO [4] pin if GPIO [4] is configured as an output pin.  Reset to 0b.
19	Reserved	RsvdP	Not Support.
20	GPIO [5] Input	HwInt RO	State of GPIO [5] pin.  Reset to 1b.
21	GPIO [5] Output Enable	RW	0b: GPIO [5] is an input pin 1b: GPIO [5] is an output pin  Reset to 0b.
22	GPIO [5] Output Register	RW	Value of this bit will be output to GPIO [5] pin if GPIO [5] is configured as an output pin.  Reset to 0b.
23	Reserved	RsvdP	Not Support.
24	GPIO [6] Input	HwInt RO	State of GPIO [6] pin.  Reset to 1b.
25	GPIO [6] Output Enable	RW	0b: GPIO [6] is an input pin 1b: GPIO [6] is an output pin  Reset to 0b.
26	GPIO [6] Output Register	RW	Value of this bit will be output to GPIO [6] pin if GPIO [6] is configured as an output pin.  Reset to 0b.
27	Reserved	RsvdP	Not Support.
28	GPIO [7] Input	HwInt RO	State of GPIO [7] pin.  Reset to 1b.
29	GPIO [7] Output Enable	RW	0b: GPIO [7] is an input pin 1b: GPIO [7] is an output pin  Reset to 0b.



BIT	FUNCTION	TYPE	DESCRIPTION
30	GPIO [7] Output Register	RW	Value of this bit will be output to GPIO [7] pin if GPIO [7] is configured as an output pin. Reset to 0b.
31	Reserved	RsvdP	Not Support.

## 7.2.68 PCI EXPRESS CAPABILITY ID REGISTER – OFFSET C0h

BIT	FUNCTION	TYPE	DESCRIPTION
7:0	Enhanced Capabilities ID	RO	Read as 10h to indicate that these are PCI express enhanced capability registers.
15:8	Next Item Pointer	RO	Read as 00h. No other ECP registers.
19:16	Capability Version	RO	Read as 2h to indicate the device is compliant to Revision .2.0 of <i>PCI Express Base Specifications</i> .
23:20	Device/Port Type	RO	Indicates the type of PCI Express logical device. Reset to 0101b (Upstream port). Reset to 0110b (Downstream ports).
24	Slot Implemented	RO	When set, indicates that the PCIe Link associated with this Port is connected to a slot. This field is valid for downstream ports of the Switch. The default value may be changed by SMBUS, I2C or auto-loading from EEPROM. Reset to 0b (Upstream port). Reset to 1b (Downstream ports).
29:25	Interrupt Message Number	RO	Read as 0b. No MSI messages are generated in the transparent mode.
31:30	Reserved	RsvdP	Not Support.

## 7.2.69 DEVICE CAPABILITIES REGISTER – OFFSET C4h

BIT	FUNCTION	TYPE	DESCRIPTION
2:0	Max_Payload_Size Supported	HwInt RO	Indicates the maximum payload size that the device can support for TLPs. Each port of the Switch supports 512 bytes max payload size. The default value may be changed by SMBUS, I2C or auto-loading from EEPROM. 000b: 128 bytes 001b: 256 bytes 010b: 512 bytes Others: Reserved Reset to 001b when PL_512B strapped pin is set to 0. Reset to 010b when PL_512B strapped pin is set to 1.
4:3	Phantom Functions Supported	RO	Indicates the support for use of unclaimed function numbers as Phantom functions. Read as 00b, since the Switch does not act as a requester. Reset to 00b.
5	Extended Tag Field Supported	RO	Indicates the maximum supported size of Tag field as a Requester. Read as 0, since the Switch does not act as a requester. Reset to 0b.
8:6	Endpoint L0s Acceptable Latency	RO	Acceptable total latency that an Endpoint can withstand due to the transition from L0s state to the L0 state. For Switch, the ASPM software would not check this value. Reset to 000b.
11:9	Endpoint L1 Acceptable Latency	RO	Acceptable total latency that an Endpoint can withstand due to the transition from L1 state to the L0 state. For Switch, the ASPM software would not check this value. Reset to 000b.
14:12	Reserved	RsvdP	Not Support.

BIT	FUNCTION	TYPE	DESCRIPTION
15	Role_Based Error Reporting	RO	When set, indicates that the device implements the functionality originally defined in the Error Reporting ECN. The default value may be changed by SMBUS, I2C or auto-loading from EEPROM.  Reset to 1b.
17:16	Reserved	RsvdP	Not Support.
25:18	Captured Slot Power Limit Value	RO	It applies to Upstream Port only. In combination with the Slot Power Limit Scale value, specifies the upper limit on power supplied by slot.  This value is set by the Set_Slot_Power_Limit message or hardwired to 00h.  Reset to 00h.
27:26	Captured Slot Power Limit Scale	RO	It applies to Upstream Port only. Specifies the scale used for the Slot Power Limit Value.  This value is set by the Set_Slot_Power_Limit message or hardwired to 00b.  Reset to 00b.
31:28	Reserved	RsvdP	Not Support.

### 7.2.70 DEVICE CONTROL REGISTER – OFFSET C8h

BIT	FUNCTION	TYPE	DESCRIPTION
0	Correctable Error Reporting Enable	RW	0b: Disable Correctable Error Reporting 1b: Enable Correctable Error Reporting  Reset to 0b.
1	Non-Fatal Error Reporting Enable	RW	0b: Disable Non-Fatal Error Reporting 1b: Enable Non-Fatal Error Reporting  Reset to 0b.
2	Fatal Error Reporting Enable	RW	0b: Disable Fatal Error Reporting 1b: Enable Fatal Error Reporting  Reset to 0b.
3	Unsupported Request Reporting Enable	RW	0b: Disable Unsupported Request Reporting 1b: Enable Unsupported Request Reporting  Reset to 0b.
4	Enable Relaxed Ordering	RO	When set, it permits the device to set the Relaxed Ordering bit in the attribute field of transaction. Since the Switch can not either act as a requester or alter the content of packet it forwards, this bit always returns '0' when read.  Reset to 0b.
7:5	Max_Payload_Size	RW	This field sets maximum TLP payload size for the device. Permissible values that can be programmed are indicated by the Max_Payload_Size Supported in the Device Capabilities register. Any value exceeding the Max_Payload_Size Supported written to this register results into clamping to the Max_Payload_Size Supported value.  Reset to 000b.
8	Extended Tag Field Enable	RW	Does not apply to PCI Express Switch. Returns '0' when read.  Reset to 0b.
9	Phantom Function Enable	RW	Does not apply to PCI Express Switch. Returns '0' when read.  Reset to 0b.
10	Auxiliary (AUX) Power PM Enable	RW	When set, indicates that a device is enabled to draw AUX power independent of PME AUX power.  Reset to 0b.

BIT	FUNCTION	TYPE	DESCRIPTION
11	Enable No Snoop	RO	When set, it permits to set the No Snoop bit in the attribute field of transaction. Since the Switch can not either act as a requester or alter the content of packet it forwards, this bit always returns '0' when read.  Reset to 0b.
14:12	Max_Read_Request_Size	RO	This field sets the maximum Read Request size for the device as a Requester. Since the Switch does not generate read request by itself, these bits are hardwired to 000b.  Reset to 000b.
15	Reserved	RsvdP	Not Support.

### 7.2.71 DEVICE STATUS REGISTER – OFFSET C8h

BIT	FUNCTION	TYPE	DESCRIPTION
16	Correctable Error Detected	RW1C	Asserted when correctable error is detected. Errors are logged in this register regardless of whether error reporting is enabled or not in the Device Control register.  Reset to 0b.
17	Non-Fatal Error Detected	RW1C	Asserted when non-fatal error is detected. Errors are logged in this register regardless of whether error reporting is enabled or not in the Device Control register.  Reset to 0b.
18	Fatal Error Detected	RW1C	Asserted when fatal error is detected. Errors are logged in this register regardless of whether error reporting is enabled or not in the Device Control register.  Reset to 0b.
19	Unsupported Request Detected	RW1C	Asserted when unsupported request is detected. Errors are logged in this register regardless of whether error reporting is enabled or not in the Device Control register.  Reset to 0b.
20	AUX Power Detected	RO	Asserted when the AUX power is detected by the Switch  Reset to 1b.
21	Transactions Pending	RO	Each port of Switch does not issue Non-posted Requests on its own behalf, so this bit is hardwired to 0b.  Reset to 0b.
31:22	Reserved	RsvdP	Not Support.

### 7.2.72 LINK CAPABILITIES REGISTER – OFFSET CCh

BIT	FUNCTION	TYPE	DESCRIPTION
3:0	Maximum Link Speed	RO	Indicates the maximum speed of the Express link.  0001b: 2.5 Gb/s 0010b: 5.0 Gb/s  Reset to 0010b.
9:4	Maximum Link Width	RO	Indicates the maximum width of the given PCIe Link.  Reset to 00_0100b (x4) (Upstream Port). Reset to 00_0010b (x2) (Downstream Ports).
11:10	Active State Power Management (ASPM) Support	RO	Indicates the level of ASPM supported on the given PCIe Link. Each port of Switch supports L0s and L1 entry. The default value may be changed by SMBUS, I2C or auto-loading from EEPROM.  Reset to 00b.

BIT	FUNCTION	TYPE	DESCRIPTION
14:12	L0s Exit Latency	RO	Indicates the L0s exit latency for the given PCIe Link. The length of time this port requires to complete transition from L0s to L0 is in the range of 256ns to less than 512ns. The default value may be changed by SMBUS, I2C or auto-loading from EEPROM.  Reset to 011b.
17:15	L1 Exit Latency	RO	Indicates the L1 exit latency for the given PCIe Link. The length of time this port requires to complete transition from L1 to L0 is in the range of 16us to less than 32us. The default value may be changed by SMBUS, I2C or auto-loading from EEPROM.  Reset to 000b.
18	Clock Power Management	RO	For upstream port, a value of 1b indicates that component tolerates the removal of any reference clock via CLKREQ#. The default value may be changed by SMBUS, I2C or auto-loading from EEPROM.  For downstream ports, this bit must be hardwired to 0b.  Reset to 1b.
19	Surprise Down Capability Enable	RO	The default value may be changed by SMBUS, I2C or auto-loading from EEPROM.  Reset to 0b.
20	Data Link Layer Active Reporting Capable	RO	For downstream ports, this bit must be set to 1b if the component supports the optional capability of reporting the DL_Active state of the Data Link Control and Management State Machine. For a hot-plug capable downstream port, this bit must be set to 1b.  For upstream port, this bit must be hardwired to 0b.  Reset to 0b (Upstream Port). Reset to 1b (Downstream Ports).
21	Link BW Notify Cap.	RO	The default value may be changed by SMBUS, I2C or auto-loading from EEPROM.  Reset to 0b (Upstream Port). Reset to 0b (Downstream Ports).
23:21	Reserved	RsvdP	Not Support.
31:24	Port Number	RO	Indicates the PCIe Port Number for the given PCIe Link. The default value may be changed by SMBUS, I2C or auto-loading from EEPROM.  Reset to 8'h00 for Port 0. Reset to 8'h01 for Port 1. Reset to 8'h02 for Port 2.

### 7.2.73 LINK CONTROL REGISTER – OFFSET D0h

BIT	FUNCTION	TYPE	DESCRIPTION
1:0	Active State Power Management (ASPM) Control	RW	00b: ASPM is Disabled 01b: L0s Entry Enabled 10b: L1 Entry Enabled 11b: L0s and L1 Entry Enabled  Note that the receiver must be capable of entering L0s even when the field is disabled.  Reset to 00b.
2	Reserved	RsvdP	Not Support.
3	Read Completion Boundary (RCB)	RO	Does not apply to PCI Express Switch. Returns '0' when read.  Reset to 0b.

BIT	FUNCTION	TYPE	DESCRIPTION
4	Link Disable	RW	At upstream port, it is not allowed to disable the link, so this bit is hardwired to '0'. For downstream ports, it disables the link when this bit is set.  Reset to 0b.
5	Retrain Link	RW	At upstream port, it is not allowed to retrain the link, so this bit is hardwired to 1'b0. For downstream ports, it initiates Link Retraining when this bit is set.  This bit always returns 0b when read.
6	Common Clock Configuration	RW	0b: The components at both ends of a link are operating with asynchronous reference clock 1b: The components at both ends of a link are operating with a distributed common reference clock  Reset to 0b.
7	Extended Synch	RW	When set, it transmits 4096 FTS ordered sets in the L0s state for entering L0 state and transmits 1024 TS1 ordered sets in the L1 state for entering L0 state.  Reset to 0b.
8	Enable Clock Power Management	RW	0b: clock power management is disable and must hold CLKREQ# low. 1b: device is permitted to use CLKREQ# to power manage Link clock.  Reset to 0b.  For downstream ports must hardwire this bit to 0b.
9	HW Autonomous Width Disable	RW	Reset to 0b.
10	Link Bandwidth Management Interrupt Enable	RO/RW	For upstream port is RO. For downstream port is RW.  Reset to 0b.
11	Link Autonomous Bandwidth Interrupt Enable	RO/RW	For upstream port is RO. For downstream port is RW.  Reset to 0b.
15:12	Reserved	RsvdP	Not Support.

## 7.2.74 LINK STATUS REGISTER – OFFSET D0h

BIT	FUNCTION	TYPE	DESCRIPTION
19:16	Link Speed	RO	Indicate the negotiated speed of the Express link.  0001b: 2.5 Gb/s 0010b: 5.0 Gb/s  Reset to 0010b.
25:20	Negotiated Link Width	RO	Indicates the negotiated width of the given PCIe link.  Reset to 00_0100b (x4) (Upstream Port). Reset to 00_0010b (x2) (Downstream Ports).
26	Training Error	RO	When set, indicates a Link training error occurred. This bit is cleared by hardware upon successful training of the link to the L0 link state.  Reset to 0b.
27	Link Training	RO	When set, indicates the link training is in progress. Hardware clears this bit once link training is complete.  Reset to 1b.

BIT	FUNCTION	TYPE	DESCRIPTION
28	Slot Clock Configuration	RO	0b: the Switch uses an independent clock irrespective of the presence of a reference on the connector 1b: the Switch uses the same reference clock that the platform provides on the connector  The default value may be changed by SMBUS, I2C or auto-loading from EEPROM.  Reset to 1b.
29	Data Link Layer Link Active	RO	Indicates the status of the Data Link Control and Management State Machine.  1b: indicate the DL_Active state 0b: otherwise  Reset to 0b.
30	Link Bandwidth Management Status	RW1C	Reset to 0b.
31	Link Autonomous Bandwidth Status	RW1C	Reset 0b.

### 7.2.75 SLOT CAPABILITIES REGISTER – OFFSET D4h (Downstream Port Only)

BIT	FUNCTION	TYPE	DESCRIPTION
0	Attention Button Present	RO	When set, it indicates that an Attention Button is implemented on the chassis for this slot. The default value may be changed by SMBUS, I2C or auto-loading from EEPROM.  Reset to 1b.
1	Power Controller Present	RO	When set, it indicates that a Power Controller is implemented for this slot. The default value may be changed by SMBUS, I2C or auto-loading from EEPROM.  Reset to 1b.
2	MRL Sensor Present	RO	When set, this bit indicates that an MRL Sensor is implemented on the chassis for this slot. The default value may be changed by SMBUS, I2C or auto-loading from EEPROM.  Reset to 1b.
3	Attention Indicator Present	RO	When set, it indicates that an Attention Indicator is implemented on the chassis for this slot. The default value may be changed by SMBUS, I2C or auto-loading from EEPROM.  Reset to 1b.
4	Power Indicator Present	RO	When set, it indicates that a Power Indicator is implemented on the chassis for this slot. The default value may be changed by SMBUS, I2C or auto-loading from EEPROM.  Reset to 1b.
5	Hot-Plug Surprise	RO	When set, it indicates that a device present in this slot might be removed from the system without any prior notification. The default value may be changed by SMBUS, I2C or auto-loading from EEPROM.  Reset to 0b.
6	Hot-Plug Capable	RO	When set, it indicates that this slot is capable of supporting Hot-Plug operation. The default value may be changed by SMBUS, I2C or auto-loading from EEPROM.  Reset to 1b.
14:7	Slot Power Limit Value	RW	It applies to downstream ports only. In combination with the Slot Power Limit Scale value, specifies the upper limit on power supplied by slot. Writes to this register also cause the Port to send the Set_Slot_Power_Limit message. The default value may be changed by SMBUS, I2C or auto-loading from EEPROM.  Reset to 19h.

BIT	FUNCTION	TYPE	DESCRIPTION
16:15	Slot Power Limit Scale	RW	It applies to downstream ports only. Specifies the scale used for the Slot Power Limit Value. Writes to this register also cause the Port to send the Set_Slot_Power_Limit message. The default value may be changed by SMBUS, I2C or auto-loading from EEPROM.  Reset to 00b.
18:17	Reserved	RsvdP	Not Support.
31:19	Physical Slot Number	RO	It indicates the physical slot number attached to this Port. The default value may be changed by SMBUS, I2C or auto-loading from EEPROM.  Reset to 0000h.

### 7.2.76 SLOT CONTROL REGISTER – OFFSET D8h (Downstream Port Only)

BIT	FUNCTION	TYPE	DESCRIPTION
0	Attention Button Pressed Enable	RW	When set, it enables the generation of Hot-Plug interrupt or wakeup event on an attention button pressed event.  Reset to 0b.
1	Power Fault Detected Enable	RW	When set, it enables the generation of Hot-Plug interrupt or wakeup event on a power fault event.  Reset to 0b.
2	MRL Sensor Enable	RW	When set, it enables the generation of Hot-Plug interrupt or wakeup even  Reset to 0b.
3	Presence Detect Changed Enable	RW	When set, it enables the generation of Hot-Plug interrupt or wakeup event on a presence detect changed event.  Reset to 0b.
4	Command Completed Interrupt Enable	RW	When set, it enables the generation of Hot-Plug interrupt when the Hot-Plug Controller completes a command.  Reset to 0b.
5	Hot-Plug Interrupt Enable	RW	When set, it enables generation of Hot-Plug interrupt on enabled Hot-Plug events.  Reset to 0b.
7:6	Attention Indicator Control	RW	Controls the display of Attention Indicator.  00b: Reserved 01b: On 10b: Blink 11b: Off  Writes to this register also cause the Port to send the ATTENTION_INDICATOR_* Messages.  Reset to 11b.
9:8	Power Indicator Control	RW	Controls the display of Power Indicator.  00b: Reserved 01b: On 10b: Blink 11b: Off  Writes to this register also cause the Port to send the POWER_INDICATOR_* Messages.  Reset to 01b.
10	Power Controller Control	RW	0b: reset the power state of the slot (Power On) 1b: set the power state of the slot (Power Off)  Reset to 0b.

BIT	FUNCTION	TYPE	DESCRIPTION
11	EM_INTRELOCK Control	RW	Reset to 0b.
12	Data Link Layer State Changed Enable	RW	If the Data Link Layer Link Active capability is implemented, when set to 1b, this field enables software notification when Data Link Layer Link Active field is changed. Reset to 0b.
15:13	Reserved	RsvdP	Not Support.

### 7.2.77 SLOT STATUS REGISTER – OFFSET D8h (Downstream Port Only)

BIT	FUNCTION	TYPE	DESCRIPTION
16	Attention Button Pressed	RW1C	When set, it indicates the Attention Button is pressed. Reset to 0b.
17	Power Fault Detected	RW1C	When set, it indicates a Power Fault is detected. Reset to 0b.
18	MRL Sensor Changed	RO	When set, it indicates a MRL Sensor Changed is detected. Reset to 0b.
19	Presence Detect Changed	RW1C	When set, it indicates a Presence Detect Changed is detected. Reset to 0b.
20	Command Completed	RW1C	When set, it indicates the Hot-Plug Controller completes an issued command. Reset to 0b.
21	MRL Sensor State	RO	Reflects the status of MRL Sensor. 0b: MRL Closed 1b: MRL Opened Reset to 0b.
22	Presence Detect State	RO	Indicates the presence of a card in the slot. 0b: Slot Empty 1b: Card Present in slot This register is implemented on all downstream ports that implement slots. For downstream ports not connected to slots (where the Slot Implemented bit of the PCI Express Capabilities register is 0b), this bit returns 1b. Reset to 0b.
23	Reserved	RsvdP	Not Support.
24	Data Link Layer State Changed	RW1C	This bit is set when the value reported in the Data Link Layer Link Active field of the Link Status register is changed.
31:25	Reserved	RsvdP	Not Support.

### 7.2.78 DEVICE CAPABILITIES REGISTER 2 – OFFSET E4h

BIT	FUNCTION	TYPE	DESCRIPTION
10:0	Device Capabilities 2	RO	Reset to 000h.
11	LTR Mechanism Supported	RO	A value of 1b indicates support for the optional Latency Tolerance Reporting (LTR) mechanism. Reset to 1b.
12	Flow Control Update Type LTR Capability Enable	RO	The default value may be changed by SMBUS, I2C or auto-loading from EEPROM. Reset to 0b.
17:13	Device Capabilities 2	RO	Reset to 00h.



BIT	FUNCTION	TYPE	DESCRIPTION
19:18	OBFF Supported	RO	This field indicates if OBFF is supported. The default value may be changed by SMBUS, I2C or auto-loading from EEPROM.  Reset to 00b.
31:20	Device Capabilities 2	RO	Reset to 000h.

### 7.2.79 DEVICE CONTROL REGISTER 2 – OFFSET E8h

BIT	FUNCTION	TYPE	DESCRIPTION
9:0	Device Control 2	RO	Reset to 000h.
10	LTR Mechanism Enable	RW	Enable LTR Mechanism.  Reset to 0b.
12:11	Device Control 2	RO	Reset to 00b.
14:13	OBFF Enable	RW	Enable OBFF Mechanism and select the signaling method.  Reset to 00b.
15	Device Control 2	RO	Reset to 0b.

### 7.2.80 DEVIDE STATUS REGISTER 2 – OFFSET E8h

BIT	FUNCTION	TYPE	DESCRIPTION
31:16	Device Status 2	RO	Reset to 0000h.

### 7.2.81 LINK CAPABILITIES REGISTER 2 – OFFSET ECh

BIT	FUNCTION	TYPE	DESCRIPTION
31:0	Link Capabilities 2	RO	Reset to 0000_0000h.

### 7.2.82 LINK CONTROL REGISTER 2 – OFFSET F0h

BIT	FUNCTION	TYPE	DESCRIPTION
3:0	Target Link Speed	RW	Reset to 0010b.
4	Enter Compliance	RW	Reset to 0b.
5	HW AutoSpeed Dis	RW	Reset to 0b.
6	Select_Deemp	RO	The default value may be changed by SMBUS, I2C or auto-loading from EEPROM. It is valid for downstream port only.  Reset to 0b (Upstream Port). Reset to 1b (Downstream Ports).
9:7	Tran Margin	RW	Reset to 000b.
10	Enter Modify Compliance	RW	Reset to 0b.
11	Compliance SOS	RW	Reset to 0b.
12	Compliance Deemp	RW	Reset to 0b.
15:13	Reserved	RsvdP	Not Support.

### 7.2.83 LINK STATUS REGISTER 2 – OFFSET F0h

BIT	FUNCTION	TYPE	DESCRIPTION
16	Current De-emphasis Level	RO	Reset to 0b (Upstream Port). Reset to 1b (Downstream Ports).
31:17	Link Status 2	RO	Reset to 0000h.

### 7.2.84 SLOT CAPABILITIES REGISTER 2 – OFFSET F4h

BIT	FUNCTION	TYPE	DESCRIPTION
31:0	Slot Capabilities 2	RO	Reset to 0000 0000h.

### 7.2.85 SLOT CONTROL REGISTER 2 – OFFSET F8h

BIT	FUNCTION	TYPE	DESCRIPTION
15:0	Slot Control 2	RO	Reset to 0000h.

### 7.2.86 SLOT STATUS REGISTER 2 – OFFSET F8h

BIT	FUNCTION	TYPE	DESCRIPTION
31:16	Slot Status 2	RO	Reset to 0000h.

### 7.2.87 PCI EXPRESS ADVANCED ERROR REPORTING CAPABILITY REGISTER – OFFSET 100h

BIT	FUNCTION	TYPE	DESCRIPTION
15:0	Extended Capabilities ID	RO	Read as 0001h to indicate that these are PCI express extended capability registers for advance error reporting.
19:16	Capability Version	RO	Read as 1h. Indicates PCI-SIG defined PCI Express capability structure version number.
31:20	Next Capability Offset	RO	Pointer points to the PCI Express Extended VC capability register. Reset to 140h.

### 7.2.88 UNCORRECTABLE ERROR STATUS REGISTER – OFFSET 104h

BIT	FUNCTION	TYPE	DESCRIPTION
0	Training Error Status	RW1C	When set, indicates that the Training Error event has occurred. Reset to 0b.
3:1	Reserved	RsvdP	Not Support.
4	Data Link Protocol Error Status	RW1C	When set, indicates that the Data Link Protocol Error event has occurred. Reset to 0b.
11:5	Reserved	RsvdP	Not Support.
12	Poisoned TLP Status	RW1C	When set, indicates that a Poisoned TLP has been received or generated. Reset to 0b.
13	Flow Control Protocol Error Status	RW1C	When set, indicates that the Flow Control Protocol Error event has occurred. Reset to 0b.
14	Completion Timeout Status	RW1C	When set, indicates that the Completion Timeout event has occurred. Reset to 0b.
15	Completer Abort Status	RW1C	When set, indicates that the Completer Abort event has occurred. Reset to 0b.
16	Unexpected Completion Status	RW1C	When set, indicates that the Unexpected Completion event has occurred. Reset to 0b.

BIT	FUNCTION	TYPE	DESCRIPTION
17	Receiver Overflow Status	RW1C	When set, indicates that the Receiver Overflow event has occurred. Reset to 0b.
18	Malformed TLP Status	RW1C	When set, indicates that a Malformed TLP has been received. Reset to 0b.
19	ECRC Error Status	RW1C	When set, indicates that an ECRC Error has been detected. Reset to 0b.
20	Unsupported Request Error Status	RW1C	When set, indicates that an Unsupported Request event has occurred. Reset to 0b.
21	ACS Violation Status	RW1C	When set, indicates that an ACS Violation event has occurred. Reset to 0b.
31:21	Reserved	RsvdP	Not Support.

### 7.2.89 UNCORRECTABLE ERROR MASK REGISTER – OFFSET 108h

BIT	FUNCTION	TYPE	DESCRIPTION
0	Training Error Mask	RW	When set, the Training Error event is not logged in the Header Log register and not issued as an Error Message to RC either. Reset to 0b.
3:1	Reserved	RsvdP	Not Support.
4	Data Link Protocol Error Mask	RW	When set, the Data Link Protocol Error event is not logged in the Header Log register and not issued as an Error Message to RC either. Reset to 0b.
11:5	Reserved	RsvdP	Not Support.
12	Poisoned TLP Mask	RW	When set, an event of Poisoned TLP has been received or generated is not logged in the Header Log register and not issued as an Error Message to RC either. Reset to 0b.
13	Flow Control Protocol Error Mask	RW	When set, the Flow Control Protocol Error event is not logged in the Header Log register and not issued as an Error Message to RC either. Reset to 0b.
14	Completion Timeout Mask	RW	When set, the Completion Timeout event is not logged in the Header Log register and not issued as an Error Message to RC either. Reset to 0b.
15	Completer Abort Mask	RW	When set, the Completer Abort event is not logged in the Header Log register and not issued as an Error Message to RC either. Reset to 0b.
16	Unexpected Completion Mask	RW	When set, the Unexpected Completion event is not logged in the Header Log register and not issued as an Error Message to RC either. Reset to 0b.
17	Receiver Overflow Mask	RW	When set, the Receiver Overflow event is not logged in the Header Log register and not issued as an Error Message to RC either. Reset to 0b.
18	Malformed TLP Mask	RW	When set, an event of Malformed TLP has been received is not logged in the Header Log register and not issued as an Error Message to RC either. Reset to 0b.
19	ECRC Error Mask	RW	When set, an event of ECRC Error has been detected is not logged in the Header Log register and not issued as an Error Message to RC either. Reset to 0b.

BIT	FUNCTION	TYPE	DESCRIPTION
20	Unsupported Request Error Mask	RW	When set, the Unsupported Request event is not logged in the Header Log register and not issued as an Error Message to RC either. Reset to 0b.
21	ACS Violation Mask	RW	Reset to 0b.
31:22	Reserved	RsvdP	Not Support.

## 7.2.90 UNCORRECTABLE ERROR SEVERITY REGISTER – OFFSET 10Ch

BIT	FUNCTION	TYPE	DESCRIPTION
0	Training Error Severity	RW	0b: Non-Fatal 1b: Fatal Reset to 1b.
3:1	Reserved	RsvdP	Not Support.
4	Data Link Protocol Error Severity	RW	0b: Non-Fatal 1b: Fatal Reset to 1b.
11:5	Reserved	RsvdP	Not Support.
12	Poisoned TLP Severity	RW	0b: Non-Fatal 1b: Fatal Reset to 0b.
13	Flow Control Protocol Error Severity	RW	0b: Non-Fatal 1b: Fatal Reset to 1b.
14	Completion Timeout Error Severity	RW	0b: Non-Fatal 1b: Fatal Reset to 0b.
15	Completer Abort Severity	RW	0b: Non-Fatal 1b: Fatal Reset to 0b.
16	Unexpected Completion Severity	RW	0b: Non-Fatal 1b: Fatal Reset to 0b.
17	Receiver Overflow Severity	RW	0b: Non-Fatal 1b: Fatal Reset to 1b.
18	Malformed TLP Severity	RW	0b: Non-Fatal 1b: Fatal Reset to 1b.
19	ECRC Error Severity	RW	0b: Non-Fatal 1b: Fatal Reset to 0b.
20	Unsupported Request Error Severity	RW	0b: Non-Fatal 1b: Fatal Reset to 0b.
21	ACS Violation Severity	RW	0b: Non-Fatal 1b: Fatal Reset to 0b.
31:21	Reserved	RsvdP	Not Support.

### 7.2.91 CORRECTABLE ERROR STATUS REGISTER – OFFSET 110 h

BIT	FUNCTION	TYPE	DESCRIPTION
0	Receiver Error Status	RW1C	When set, the Receiver Error event is detected. Reset to 0b.
5:1	Reserved	RsvdP	Not Support.
6	Bad TLP Status	RW1C	When set, the event of Bad TLP has been received is detected. Reset to 0b.
7	Bad DLLP Status	RW1C	When set, the event of Bad DLLP has been received is detected. Reset to 0b.
8	REPLAY_NUM Rollover Status	RW1C	When set, the REPLAY_NUM Rollover event is detected. Reset to 0b.
11:9	Reserved	RsvdP	Not Support.
12	Replay Timer Timeout Status	RW1C	When set, the Replay Timer Timeout event is detected. Reset to 0b.
13	Advisory Non-Fatal Error Status	RW1C	When set, the Advisory Non-Fatal Error event is detected. Reset to 0b.
31:14	Reserved	RsvdP	Not Support.

### 7.2.92 CORRECTABLE ERROR MASK REGISTER – OFFSET 114 h

BIT	FUNCTION	TYPE	DESCRIPTION
0	Receiver Error Mask	RW	When set, the Receiver Error event is not logged in the Header Log register and not issued as an Error Message to RC either. Reset to 0b.
5:1	Reserved	RsvdP	Not Support.
6	Bad TLP Mask	RW	When set, the event of Bad TLP has been received is not logged in the Header Log register and not issued as an Error Message to RC either. Reset to 0b.
7	Bad DLLP Mask	RW	When set, the event of Bad DLLP has been received is not logged in the Header Log register and not issued as an Error Message to RC either. Reset to 0b.
8	REPLAY_NUM Rollover Mask	RW	When set, the REPLAY_NUM Rollover event is not logged in the Header Log register and not issued as an Error Message to RC either. Reset to 0b.
11:9	Reserved	RsvdP	Not Support.
12	Replay Timer Timeout Mask	RW	When set, the Replay Timer Timeout event is not logged in the Header Log register and not issued as an Error Message to RC either. Reset to 0b.
13	Advisory Non-Fatal Error Mask	RW	When set, the Advisory Non-Fatal Error event is not logged in the Header Long register and not issued as an Error Message to RC either. Reset to 1b.
31:14	Reserved	RsvdP	Not Support.

### 7.2.93 ADVANCE ERROR CAPABILITIES AND CONTROL REGISTER – OFFSET 118h

BIT	FUNCTION	TYPE	DESCRIPTION
4:0	First Error Pointer	RO	It indicates the bit position of the first error reported in the Uncorrectable Error Status register. Reset to 0 0000b.
5	ECRC Generation Capable	RO	When set, it indicates the Switch has the capability to generate ECRC. Reset to 1b.
6	ECRC Generation Enable	RW	When set, it enables the generation of ECRC when needed. Reset to 0b.
7	ECRC Check Capable	RO	When set, it indicates the Switch has the capability to check ECRC. Reset to 1b.
8	ECRC Check Enable	RW	When set, the function of checking ECRC is enabled. Reset to 0b.
31:9	Reserved	RsvdP	Not Support.

### 7.2.94 HEADER LOG REGISTER – OFFSET From 11Ch to 128h

BIT	FUNCTION	TYPE	DESCRIPTION
31:0	1 <sup>st</sup> DWORD	RO	Hold the 1st DWORD of TLP Header. The Head byte is in big endian.
63:32	2 <sup>nd</sup> DWORD	RO	Hold the 2nd DWORD of TLP Header. The Head byte is in big endian.
95:64	3 <sup>rd</sup> DWORD	RO	Hold the 3rd DWORD of TLP Header. The Head byte is in big endian.
127:96	4 <sup>th</sup> DWORD	RO	Hold the 4th DWORD of TLP Header. The Head byte is in big endian.

### 7.2.95 PCI EXPRESS VIRTUAL CHANNEL CAPABILITY REGISTER – OFFSET 140h

BIT	FUNCTION	TYPE	DESCRIPTION
15:0	Extended Capabilities ID	RO	Read as 0002h to indicate that these are PCI express extended capability registers for virtual channel.
19:16	Capability Version	RO	Read as 1h. Indicates PCI-SIG defined PCI Express capability structure version number.
31:20	Next Capability Offset	RO	Pointer points to the PCI Express Power Budgeting Capability register. Reset to 20Ch.

### 7.2.96 PORT VC CAPABILITY REGISTER 1 – OFFSET 144h

BIT	FUNCTION	TYPE	DESCRIPTION
2:0	Extended VC Count	RO	It indicates the number of extended Virtual Channels in addition to the default VC supported by the Switch. The default value may be changed by SMBUS, I2C or auto-loading from EEPROM. Reset to 000b.
3	Reserved	RsvdP	Not Support.
6:4	Low Priority Extended VC Count	RO	It indicates the number of extended Virtual Channels in addition to the default VC belonging to the low-priority VC (LPVC) group. The default value may be changed by SMBUS, I2C or auto-loading from EEPROM. Reset to 000b.
7	Reserved	RsvdP	Not Support.

BIT	FUNCTION	TYPE	DESCRIPTION
9:8	Reference Clock	RO	It indicates the reference clock for Virtual Channels that support time-based WRR Port Arbitration. Defined encoding is 00b for 100 ns reference clock.  Reset to 00b.
11:10	Port Arbitration Table Entry Size	RO	Read as 2'b10 to indicate the size of Port Arbitration table entry in the device is 4 bits.  Reset to 10b.
31:12	Reserved	RsvdP	Not Support.

### 7.2.97 PORT VC CAPABILITY REGISTER 2 – OFFSET 148h

BIT	FUNCTION	TYPE	DESCRIPTION
7:0	VC Arbitration Capability	RO	It indicates the types of VC Arbitration supported by the device for the LPVC group. This field is valid when LPVC is greater than 0. The Switch supports Hardware fixed arbitration scheme, e.g., Round Robin and Weight Round Robin arbitration with 32 phases in LPVC.  Reset to 00h if offset 144h.bit[2:0]=0. Reset to 03h if offset 144h.bit[2:0]=1.
23:8	Reserved	RsvdP	Not Support.
31:24	VC Arbitration Table Offset	RO	It indicates the location of the VC Arbitration Table as an offset from the base address of the Virtual Channel Capability register in the unit of DQWD (16 bytes).  Reset to 00h if offset 144h.bit[2:0]=0. Reset to 03h if offset 144h.bit[2:0]=1.

### 7.2.98 PORT VC CONTROL REGISTER – OFFSET 14Ch

BIT	FUNCTION	TYPE	DESCRIPTION
0	Load VC Arbitration Table	RW	When set, the programmed VC Arbitration Table is applied to the hardware. This bit always returns 0b when read.  Reset to 0b.
3:1	VC Arbitration Select	RW	This field is used to configure the VC Arbitration by selecting one of the supported VC Arbitration schemes. The valid values for the schemes supported by Switch are 0b and 1b. Other value than these written into this register will be treated as default.  Reset to 000b.
15:4	Reserved	RsvdP	Not Support.

### 7.2.99 PORT VC STATUS REGISTER – OFFSET 14Ch

BIT	FUNCTION	TYPE	DESCRIPTION
16	VC Arbitration Table Status	RO	When set, it indicates that any entry of the VC Arbitration Table is written by software. This bit is cleared when hardware finishes loading values stored in the VC Arbitration Table after the bit of “Load VC Arbitration Table” is set.  Reset to 0b.
31:17	Reserved	RsvdP	Not Support.

### 7.2.100 VC RESOURCE CAPABILITY REGISTER (0) – OFFSET 150h

BIT	FUNCTION	TYPE	DESCRIPTION
7:0	Port Arbitration Capability	RO	It indicates the types of Port Arbitration supported by the VC resource. The Switch supports Hardware fixed arbitration scheme, e.g., Round Robin, Weight Round Robin (WRR) arbitration with 128 phases (3~4 enabled ports) and Time-based WRR with 128 phases (3~4 enabled ports). Note that the Time-based WRR is only valid in VC1.  Reset to 09h.
13:8	Reserved	RsvdP	Not Support.
14	Advanced Packet Switching	RO	When set, it indicates the VC resource only supports transaction optimized for Advanced Packet Switching (AS).  Reset to 0b.
15	Reject Snoop Transactions	RO	This bit is not applied to PCIe Switch.  Reset to 0b.
22:16	Maximum Time Slots	RO	It indicates the maximum numbers of time slots (minus one) are allocated for Isochronous traffic.  Reset to 7Fh.
23	Reserved	RsvdP	Not Support.
31:24	Port Arbitration Table Offset	RO	It indicates the location of the Port Arbitration Table (n) as an offset from the base address of the Virtual Channel Capability register in the unit of DQWD (16 bytes).  Reset to 04h for Port Arbitration Table (0).

### 7.2.101 VC RESOURCE CONTROL REGISTER (0) – OFFSET 154h

BIT	FUNCTION	TYPE	DESCRIPTION
7:0	TC/VC Map	RW	This field indicates the TCs that are mapped to the VC resource. Bit locations within this field correspond to TC values. When the bits in this field are set, it means that the corresponding TCs are mapped to the VC resource. The default value may be changed by SMBUS, I2C or auto-loading from EEPROM.  Reset to FFh.
15:8	Reserved	RsvdP	Not Support.
16	Load Port Arbitration Table	RW	When set, the programmed Port Arbitration Table is applied to the hardware. This bit always returns 0b when read.  Reset to 0b
19:17	Port Arbitration Select	RW	This field is used to configure the Port Arbitration by selecting one of the supported Port Arbitration schemes. The permissible values for the schemes supported by Switch are 000b and 011b at VC0, other value than these written into this register will be treated as default.  Reset to 000b.
23:20	Reserved	RsvdP	Not Support.
26:24	VC ID	RO	This field assigns a VC ID to the VC resource.  Reset to 000b.
30:27	Reserved	RsvdP	Not Support.
31	VC Enable	RW	0b: disables this Virtual Channel 1b: enables this Virtual Channel  Reset to 1b.



### 7.2.102 VC RESOURCE STATUS REGISTER (0) – OFFSET 158h

BIT	FUNCTION	TYPE	DESCRIPTION
15:0	Reserved	RsvdP	Not Support.
16	Port Arbitration Table Status	RO	When set, it indicates that any entry of the Port Arbitration Table is written by software. This bit is cleared when hardware finishes loading values stored in the Port Arbitration Table after the bit of “Load Port Arbitration Table” is set.  Reset to 0b.
17	VC Negotiation Pending	RO	When set, it indicates that the VC resource is still in the process of negotiation. This bit is cleared after the VC negotiation is complete.  Reset to 0b.
31:18	Reserved	RsvdP	Not Support.

### 7.2.103 VC RESOURCE CAPABILITY REGISTER (1) – OFFSET 15Ch

BIT	FUNCTION	TYPE	DESCRIPTION
7:0	Port Arbitration Capability	RO	It indicates the types of Port Arbitration supported by the VC resource. The Switch supports Hardware fixed arbitration scheme, e.g., Round Robin, Weight Round Robin (WRR) arbitration with 128 phases (3~4 enabled ports) and Time-based WRR with 128 phases (3~4 enabled ports). Note that the Time-based WRR is only valid in VC1.  Reset to 00h if offset 144h.bit[2:0]=0. Reset to 19h if offset 144h.bit[2:0]=1.
13:8	Reserved	RsvdP	Not Support.
14	Advanced Packet Switching	RO	When set, it indicates the VC resource only supports transaction optimized for Advanced Packet Switching (AS).  Reset to 0b.
15	Reject Snoop Transactions	RO	This bit is not applied to PCIe Switch.  Reset to 0b.
22:16	Maximum Time Slots	RO	It indicates the maximum numbers of time slots (minus one) are allocated for Isochronous traffic. The default value may be changed by SMBUS, I2C or auto-loading from EEPROM.  Reset to 00h if offset 144h.bit[2:0]=0. Reset to 7Fh if offset 144h.bit[2:0]=1.
23	Reserved	RsvdP	Not Support.
31:24	Port Arbitration Table Offset	RO	It indicates the location of the Port Arbitration Table (n) as an offset from the base address of the Virtual Channel Capability register in the unit of DQWD (16 bytes).  Reset to 00h for Port Arbitration Table (1) if offset 144h.bit[2:0]=0. Reset to 08h for Port Arbitration Table (1) if offset 144h.bit[2:0]=1.

### 7.2.104 VC RESOURCE CONTROL REGISTER (1) – OFFSET 160h

BIT	FUNCTION	TYPE	DESCRIPTION
7:0	TC/VC Map	RW (Exception for bit0)	This field indicates the TCs that are mapped to the VC resource. Bit locations within this field correspond to TC values. When the bits in this field are set, it means that the corresponding TCs are mapped to the VC resource. Bit 0 of this field is read-only and must be set to “0” for the VC1. The default value may be changed by SMBUS, I2C or auto-loading from EEPROM.  Reset to 00h.
15:8	Reserved	RsvdP	Not Support.

BIT	FUNCTION	TYPE	DESCRIPTION
16	Load Port Arbitration Table	RW	When set, the programmed Port Arbitration Table is applied to the hardware. This bit always returns 0b when read.  Reset to 0b.
19:17	Port Arbitration Select	RW	This field is used to configure the Port Arbitration by selecting one of the supported Port Arbitration schemes. The permissible values for the schemes supported by Switch are 000b, 011b and 100b at VC1, other value than these written into this register will be treated as default.  Reset to 000b.
23:20	Reserved	RO	Reset to 4'h0.
26:24	VC ID	RW	This field assigns a VC ID to the VC resource.  Reset to 000h if offset 144h.bit[2:0]=0. Reset to 001h if offset 144h.bit[2:0]=1.
30:27	Reserved	RsvdP	Not Support.
31	VC Enable	RW	0b: disables this Virtual Channel 1b: enables this Virtual Channel  Reset to 0b.

### 7.2.105 VC RESOURCE STATUS REGISTER (1) – OFFSET 164h

BIT	FUNCTION	TYPE	DESCRIPTION
15:0	Reserved	RsvdP	Not Support.
16	Port Arbitration Table Status	RO	When set, it indicates that any entry of the Port Arbitration Table is written by software. This bit is cleared when hardware finishes loading values stored in the Port Arbitration Table after the bit of “Load Port Arbitration Table” is set.  Reset to 0b.
17	VC Negotiation Pending	RO	When set, it indicates that the VC resource is still in the process of negotiation. This bit is cleared after the VC negotiation is complete.  Reset to 0b.
31:18	Reserved	RsvdP	Not Support.

### 7.2.106 VC ARBITRATION TABLE REGISTER – OFFSET 170h

The VC arbitration table is a read-write register array that contains a table for VC arbitration. Each table entry allocates four bits, of which three bits are used to represent VC ID and one bit is reserved. A total of 32 entries are used to construct the VC arbitration table. The layout for this register array is shown below.

**Table 7-1 Register Array Layout for VC Arbitration**

31 - 28	27 - 24	23 - 20	19 - 16	15 - 12	11 - 8	7 - 4	3 - 0	Byte Location
Phase [7]	Phase [6]	Phase [5]	Phase [4]	Phase [3]	Phase [2]	Phase [1]	Phase [0]	00h
Phase [15]	Phase [14]	Phase [13]	Phase [12]	Phase [11]	Phase [10]	Phase [9]	Phase [8]	04h
Phase [23]	Phase [22]	Phase [21]	Phase [20]	Phase [19]	Phase [18]	Phase [17]	Phase [16]	08h
Phase [31]	Phase [30]	Phase [29]	Phase [28]	Phase [27]	Phase [26]	Phase [25]	Phase [24]	0Ch

### 7.2.107 PORT ARBITRATION TABLE REGISTER (0) and (1) – OFFSET 180h and 1C0h

The Port arbitration table is a read-write register array that contains a table for Port arbitration. Each table entry allocates two bits to represent Port Number. The table entry size is dependent on the number of enabled ports (refer to bit 10 and 11 of Port VC capability register 1). The arbitration table contains 128 entries if three or four ports are to be enabled. The following table shows the register array layout for the size of entry equal to two.

**Table 7-2 Table Entry Size in 4 Bits**

63 - 56	55 - 48	47 - 40	39 - 32	31 - 24	23 - 16	15 - 8	7 - 0	Byte Location
Phase [15:14]	Phase [13:12]	Phase [11:10]	Phase [9:8]	Phase [7:6]	Phase [5:4]	Phase [3:2]	Phase [1:0]	00h
Phase [31:30]	Phase [29:28]	Phase [27:26]	Phase [25:24]	Phase [23:22]	Phase [21:20]	Phase [19:18]	Phase [17:16]	08h
Phase [47:46]	Phase [45:44]	Phase [43:42]	Phase [41:40]	Phase [39:38]	Phase [37:36]	Phase [35:34]	Phase [33:32]	10h
Phase [63:62]	Phase [61:60]	Phase [59:58]	Phase [57:56]	Phase [55:54]	Phase [53:52]	Phase [51:50]	Phase [49:48]	18h
Phase [79:78]	Phase [77:76]	Phase [75:74]	Phase [73:72]	Phase [71:70]	Phase [69:68]	Phase [67:66]	Phase [65:64]	20h
Phase [95:94]	Phase [93:92]	Phase [91:90]	Phase [89:88]	Phase [87:86]	Phase [85:84]	Phase [83:82]	Phase [81:80]	28h
Phase [111:110]	Phase [109:108]	Phase [107:106]	Phase [105:104]	Phase [103:102]	Phase [101:100]	Phase [99:98]	Phase [97:96]	30h
Phase [127:126]	Phase [125:124]	Phase [123:122]	Phase [121:120]	Phase [119:118]	Phase [117:116]	Phase [115:114]	Phase [113:112]	38h

### 7.2.108 PCI EXPRESS POWER BUDGETING CAPABILITY REGISTER – OFFSET 20Ch

BIT	FUNCTION	TYPE	DESCRIPTION
15:0	Extended Capabilities ID	RO	Read as 0004h to indicate that these are PCI express extended capability registers for power budgeting.
19:16	Capability Version	RO	Read as 1h. Indicates PCI-SIG defined PCI Express capability structure version number.
31:20	Next Capability Offset	RO	Pointer points to the PCI Express Extended ACS capability register /LTR capability register. Reset to 230h (Upstream Port). Reset to 220h (Downstream Ports).

### 7.2.109 DATA SELECT REGISTER – OFFSET 210h

BIT	FUNCTION	TYPE	DESCRIPTION
7:0	Data Selection	RW	It indexes the power budgeting data reported through the data register. When 00h, it selects D0 Max power budget When 01h, it selects D0 Sustained power budget Other values would return zero power budgets, which means not supported Reset to 00h.
31:8	Reserved	RsvdP	Not Support.

### 7.2.110 POWER BUDGETING DATA REGISTER – OFFSET 214h

BIT	FUNCTION	TYPE	DESCRIPTION
7:0	Base Power	RO	It specifies the base power value in watts. This value represents the required power budget in the given operation condition. The default value may be changed by SMBUS, I2C or auto-loading from EEPROM.  Reset to 04h.
9:8	Data Scale	RO	It specifies the scale to apply to the base power value. The default value may be changed by SMBUS, I2C or auto-loading from EEPROM.  Reset to 00b.
12:10	PM Sub State	RO	It specifies the power management sub state of the given operation condition. It is initialized to the default sub state.  Reset to 000b.
14:13	PM State	RO	It specifies the power management state of the given operation condition. It defaults to the D0 power state. The default value may be changed by SMBUS, I2C or auto-loading from EEPROM.  Reset to 00b.
17:15	Type	RO	It specifies the type of the given operation condition. It defaults to the Maximum power state.  Reset to 111b.
20:18	Power Rail	RO	It specifies the power rail of the given operation condition.  Reset to 010b.
31:21	Reserved	RsvdP	Not Support.

### 7.2.111 POWER BUDGET CAPABILITY REGISTER – OFFSET 218h

BIT	FUNCTION	TYPE	DESCRIPTION
0	System Allocated	RO	When set, it indicates that the power budget for the device is included within the system power budget. The default value may be changed by SMBUS, I2C or auto-loading from EEPROM.  Reset to 0b.
31:1	Reserved	RsvdP	Not Support.

### 7.2.112 ACS EXTENDED CAPABILITY HEADER – OFFSET 220h (Downstream Port Only)

BIT	FUNCTION	TYPE	DESCRIPTION
15:0	PCI Express Extended Capability ID	RO	Read as 000Dh to indicate PCI Express Extended Capability ID for ACS Extended Capability.
19:16	Capability Version	RO	Must be 1h for this version.
31:20	Next Capability ID	RO	Pointer points to the PCI Express Extended L1PM Substates Extended Capability Header register.  Reset to 240h.

### 7.2.113 ACS CAPABILITY REGISTER – OFFSET 224h (Downstream Port Only)

BIT	FUNCTION	TYPE	DESCRIPTION
0	ACS Source Validation	RO	Indicated the implements of ACS Source Validation. Reset to 1b.
1	ACS Translation Blocking	RO	Indicated the implements of ACS Translation Blocking. Reset to 1b.
2	ACS P2P Request Redirect	RO	Indicated the implements of ACS P2P Request Redirect. Reset to 1b.
3	ACS P2P Completion Redirect	RO	Indicated the implements of ACS P2P Completion Redirect. Reset to 1b.
4	ACS Upstream Forwarding	RO	Indicated the implements of ACS Upstream Forwarding. Reset to 1b.
5	ACS P2P Egress control	RO	Indicated the implements of ACS P2P Egress control. Reset to 1b.
6	ACS Direct Translated P2P	RO	Indicated the implements of ACS Direct Translated P2P. Reset to 1b.
7	Reserved	RsvdP	Not Support.
15:8	Egress Control Vector Size	RO	Encodings 01h – FFh directly indicate the number of applicable bits in the Egress Control Vector. Reset to 08h.
16	ACS Source Validation Enable	RW	Enable the source validation. Reset to 0b.
17	ACS Translation Blocking Enable	RW	Enable ACS Translation Blocking. Reset to 0b.
18	ACS P2P Request Redirect	RW	Enable ACS P2P Request Redirect. Reset to 0b.
19	ACS P2P Completion Redirect Enable	RW	Enable ACS P2P Completion Redirect. Reset to 0b.
20	ACS Upstream Forwarding Enable	RW	Enable ACS Upstream Forwarding. Reset to 0b.
21	ACS P2P Egress control Enable	RW	Enable ACS P2P Egress control. Reset to 0b.
22	ACS Direct Translated P2P Enable	RW	Enable ACS Direct Translated P2P. Reset to 0b.
31:23	Reserved	RsvdP	Not Support.

### 7.2.114 EGRESS CONTROL VECTOR – OFFSET 228h (Downstream Port Only)

BIT	FUNCTION	TYPE	DESCRIPTION
7:0	Egress Control Vector	RW	When a given bit is set, peer-to-peer requests targeting the associated Port are blocked or redirected. Reset to 00h.
31:8	Reserved	RsvdP	Not Support.

### 7.2.115 LTR EXTENDED CAPABILITY HEADER – OFFSET 230h (Upstream Port Only)

BIT	FUNCTION	TYPE	DESCRIPTION
15:0	PCI Express Extended Capability ID	RO	Read as 0018h to indicate PCI Express Extended Capability ID for LTR Extended Capability.
19:16	Capability Version	RO	Must be 1h for this version.
31:20	Next Capability ID	RO	Pointer points to the PCI Express Extended L1PM Substates Extended Capability Header register. Reset to 240h.

### 7.2.116 MAX SNOOP LATENCY REGISTER – OFFSET 234h (Upstream Port Only)

BIT	FUNCTION	TYPE	DESCRIPTION
9:0	Max Snoop Latency Value	RW	.Specifies the maximum snoop latency that a device is permitted to request Reset to 000h.
12:10	Max Snoop Latency Scale	RW	This register provides a scale for the value contained within the Maximum Snoop Latency Value field Reset to 000b.
15:13	Reserved	RsvdP	Not Support.

### 7.2.117 MAX NO-SNOOP LATENCY REGISTER – OFFSET 234h (Upstream Port Only)

BIT	FUNCTION	TYPE	DESCRIPTION
25:16	Max No-Snoop Latency Value	RW	.Specifies the maximum no-snoop latency that a device is permitted to request Reset to 000h.
28:26	Max No-Snoop Latency Scale	RW	This register provides a scale for the value contained within the Maximum No-Snoop Latency Value field Reset to 000b.
31:29	Reserved	RsvdP	Not Support.

### 7.2.118 L1 PM SUBSTATES EXTENDED CAPABILITY HEADER – OFFSET 240h

BIT	FUNCTION	TYPE	DESCRIPTION
15:0	PCI Express Extended Capability ID	RO	Read as 001Eh to indicate PCI Express Extended Capability ID for L1 PM Substates Extended Capability.
19:16	Capability Version	RO	Must be 1h for this version.
31:20	Next Capability ID	RO	Read as 000h. No other ECP registers.

### 7.2.119 L1 PM SUBSTATES CAPABILITY REGISTER – OFFSET 244h

BIT	FUNCTION	TYPE	DESCRIPTION
0	Reserved	RsvdP	Not Support.

BIT	FUNCTION	TYPE	DESCRIPTION
1	PCI-PM L1.1 Supported	RO	When set this bit indicates that PCI-PM L1.1 is supported and must be set by all ports implementing L1 OM Substates. The default value may be changed by SMBus, I2C or auto-loading from EEPROM.  Reset to 1b.
2	Reserved	RsvdP	Not Support.
3	ASPM L1.1 Supported	RO	When set this bit indicates that ASPM L1.1 is supported. The default value may be changed by SMBus, I2C or auto-loading from EEPROM.  Reset to 0b.
4	L1 PM Substates Supported	RO	When set this bit indicates that this port supports L1 PM Substates. The default value may be changed by SMBus, I2C or auto-loading from EEPROM.  Reset to 1b.
31:5	Reserved	RsvdP	Not Support.

### 7.2.120 L1 PM SUBSTATES CONTROL 1 REGISTER – OFFSET 248h

BIT	FUNCTION	TYPE	DESCRIPTION
0	Reserved	RsvdP	Not Support.
1	PCI-PM L1.1 Enable	RW	When set this bit enables PCI-PM L1.1. Required for both upstream and downstream ports.  Reset to 0b.
2	Reserved	RsvdP	Not Support.
3	ASPM L1.1 Enable	RW	When set this bit enables ASPM L1.1. Required for both upstream and downstream ports.  Reset to 0b.
31:4	Reserved	RsvdP	Not Support.

### 7.2.121 L1 PM SUBSTATES CONTROL 2 REGISTER – OFFSET 24Ch

BIT	FUNCTION	TYPE	DESCRIPTION
31:0	Reserved	RO	Reset to 0000 0000h.

### 7.2.122 LTSSM\_CSR REGISTER – OFFSET 33Ch

BIT	FUNCTION	TYPE	DESCRIPTION
7:0	LTSSM_CSR	RO	The default value may be changed by SMBUS, I2C or auto-loading from EEPROM.  Reset to 00h.
31:8	Reserved	RsvdP	Not Support.

### 7.2.123 HOTPLUG\_CSR REGISTER – OFFSET 340h

BIT	FUNCTION	TYPE	DESCRIPTION
15:0	Hotplug_CSR	RO	The default value may be changed by SMBUS, I2C or auto-loading from EEPROM.  Reset to 0000h.

### 7.2.124 MAC\_CSR1 REGISTER – OFFSET 340h

BIT	FUNCTION	TYPE	DESCRIPTION
31:16	MAC_CSR1	RO	The default value may be changed by SMBUS, I2C or auto-loading from EEPROM. Reset to 0004h.

### 7.2.125 SMBUS CONTROL REGISTER – OFFSET 344h (Upstream Port Only)

BIT	FUNCTION	TYPE	DESCRIPTION
0	SMBus Enable	RW	0b: disable SMBUS, enable I2C 1b: enable SMBUS Reset to 1b.
7:1	SMBUS Address	HwInt RW	Set SMBUS Address. Bit [7:4] reset to 1101b. Bit [3:1] are decided by the status of strapped pins (GPIO[7:5]).
8	Reserved	RsvdP	Not Support.
9	PEC Check Disable	RW	0b: enable PEC check 1b: disable PEC check Reset to 1b.
28:10	Reserved	RsvdP	Not Support.
29	PEC Check Fail	RW1C	0b: PEC check successfully 1b: PEC check failed Reset to 0b.
30	Unsupported SMBUS Command	RW1C	0b: supported command. 1b: unsupported command. Reset to 0b.
31	Reserved	RsvdP	Not Support.

### 7.2.126 CPLD FLOW CONTRL ENABLE REGISTER– OFFSET 350h (Upstream Port Only)

BIT	FUNCTION	TYPE	DESCRIPTION
0	Reserved	RsvdP	Not Support.
1	Port 1 CPLD Flow Control Enable	RW	Enable port 1 CPLD flow control Reset to 0b.
2	Port 2 CPLD Flow Control Enable	RW	Enable port 2 CPLD flow control Reset to 0b.
31:3	Reserved	RsvdP	Not Support.

### 7.2.127 CPLD FLOW CONTROL THRESHOLD REGISTER – OFFSET 354h (Upstream Port Only)

BIT	FUNCTION	TYPE	DESCRIPTION
15:0	X1 CPLD Flow Control Threshold	RW	Threshold for x1 link Reset to 0080h.



BIT	FUNCTION	TYPE	DESCRIPTION
31:16	X2 CPLD Flow Control Threshold	RW	Threshold for x2 link Reset to 0200h.

#### 7.2.128 CPLD FLOW CONTROL THRESHOLD REGISTER – OFFSET 358h (Upstream Port Only)

BIT	FUNCTION	TYPE	DESCRIPTION
15:0	X4 CPLD Flow Control Threshold	RW	Threshold for x4 link Reset to 0800h.
31:16	Reserved	RsvdP	Not Support.

#### 7.2.129 POWER DAVING DISABLE REGISTER – OFFSET 360h

BIT	FUNCTION	TYPE	DESCRIPTION
0	Power Saving Disable	RW	Disable power saving. The default value may be changed by SMBus, I2C or auto-loading from EEPROM. Reset to 0b.
31:1	Reserved	RsvdP	Not Support.

#### 7.2.130 LED DISPLAY CSR 364h (Upstream Port Only)

BIT	FUNCTION	TYPE	DESCRIPTION
4:0	LED Display Mode Select	RW	Reset to 0_0000b.
5	LED Enable	RW	Reset to 0b.
6	LED Mode	RW	Reset to 0b.
31:7	Reserved	RsvdP	Not Support.

## 8 CLOCK SCHEME

The built-in Integrated Reference Clock Buffer of the PI7C9X2G308GP supports seven reference clock outputs. The clock buffer feature can be enabled and disabled by strapping the CLKBUF\_PD pin.

When CLKBUF\_PD pin is asserted low, the clock buffer is enabled. The clock buffer distributes a single 100MHz reference clock input to Seven Reference Clock Output Pairs, REFCLKOP [7:1] and REFCLKON [7:1]. The clock buffer requires 100MHz differential clock inputs through REFCLKIP and REFCLKIN Pins as show in Table 8-1. If want to disable some specified Reference Clock Output Paris, it can be done by Clock Buffer Control field in the Operation Mode Register (offset 98h. bit[23:16]) through I2C, SMBUS or EEPROM.

**Table 8-1 DC Electrical Characteristics**

Symbol	Parameters	Min.	Typ.	Max.	Unit
$F_{IN}$	Reference Clock Frequency		100		MHz
$T_{rise}/T_{fall}^1$	Rise and Fall Time in 20-80%	175		700	ps
$DT_{rise}/DT_{fall}^1$	Rise and Fall Time Variation			125	ps
$T_{pd}$	Propagation Delay	2.5		6.5	ns
$V_{swing}^1$	Voltage including overshoot	550		1150	mV
$T_{DC}^2$	Duty Cycle	45		55	%

**Note:**

1. Measurement taken from Single Ended waveform.
2. Measurement taken from Differential waveform.

When CLKBUF\_PD pin is asserted high, the clock buffer is disabled. The 100MHz Reference Clock Output Pairs are disabled, and The PI7C9X2G308GP requires 100MHz differential clock inputs through REFCLKP and REFCLKN Pins as shown in table 8-2.

**Table 8-2 DC Electrical Characteristics**

Description	Symbol	Min	Typ	Max	Unit
Reference Clock Frequency*	$f_i$		100		MHz
Accuracy	$A_i$	-300		+300	ppm
Duty Cycle	$DC_i$	45		55	%
> 1.5 MHz to Nyquist RMS jitter after applying PCIe filter function	$T_{REFCLK-HF-RMS}$	-		3.1	ps RMS
10 kHz - 1.5 MHz RMS jitter	$T_{REFCLK-LF-RMS}$	-		3.0	ps RMS
Spread Spectrum Clock frequency	$SS_{freq}$	30		33	kHz

\* Does not include  $\pm 300$ ppm. Only certain clock frequencies will produce valid PCI Express data.

## 9 POWER MANAGEMENT

The PI7C9X2G308GP supports D0, D1, D2, D3-hot, and D3-cold Power States. The PCI Express Physical Link Layer of the PI7C9X2G308GP device supports the PCI Express Link Power Management with L0, L0s, L1, L2/L3 ready and L3 Power States. PI7C9X2G308GP also supports ASPM (Active State Power Management) to facilitate the link power saving.

The highest power-saving link power state is L2/L3. In this state, the main power and auxiliary power (if existing) are off. It typically implies the entire system is shut down when all links enter into L2/L3. In this packet switch, the link of each downstream port is allowed to stay in L2/L3 individually and only turning off the main/auxiliary power applied to the device connected to the specific link. This particular power-saving mechanism is due to the packet switch's capability to issue a "device-specific PME turn-off message" for the chosen device. Once the device receives PME turn-off message, it responds to PME turn-off ACK message and initiates the process of entering the link in L2/L3 state. The system software then directs packet switch to control power module for terminating power delivery to the device. To recover from L2/L3 state, the system software notifies packet switch to enable the power and then issues a dedicated reset for that device. The PI7C9X2G308GP defines a configuration register located at offset 9Ch for controlling and monitoring the device to enter into or leave from device-specific L2/L3 state. This register is defined only in the downstream ports of the packet switch.

In addition to device or link level of power management, the PI7C9X2G308GP also supports platform-wide power saving by implementing Latency Tolerance Reporting (LTR) and Optimized Buffer Flush/Fill (OBFF) mechanisms to synchronize both Root Complex and Device entering or leaving power down state in almost the same time window. This can prevent unconditionally waking up the Root Complex or device to make power saving much efficient.

## 10 POWER SEQUENCE

As long as PERST# is active, all PCI Express functions are held in reset. The main supplies ramp up to their specified levels (3.3V). Sometime during this stabilization time, the REFCLK starts and stabilizes. After there has been time (100 ms) for the power and clock to become stable, PERST# is deasserted high and the PCI Express functions can start up.

It is recommended to power up the I/O voltage (3.3V) first and then the core voltage (1.0V) or power up I/O voltage and core voltage simultaneously.

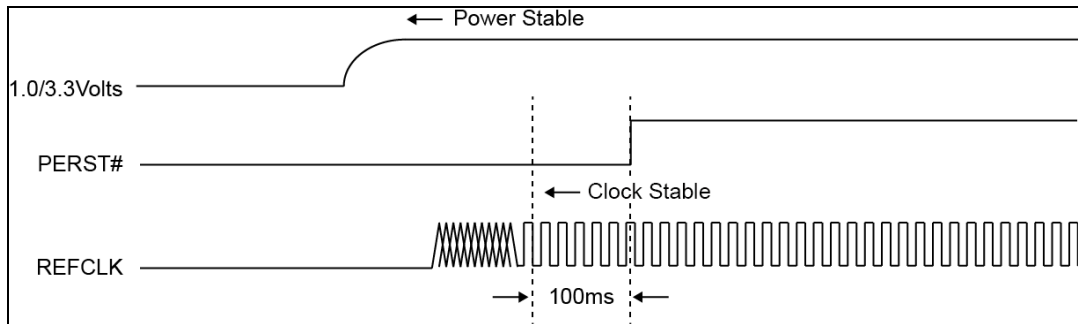

**Figure 10-1 Initial Power-Up Sequence**

Power-down sequence is the reverse of power-up sequence.

## 11 ELECTRICAL AND TIMING SPECIFICATIONS

### 11.1 ABSOLUTE MAXIMUM RATINGS

Table 11-1 Absolute Maximum Ratings

(Above which the useful life may be impaired. For user guidelines, not tested.)

Item	Absolute Max. Rating
Storage Temperature	-65°C to 150°C
Junction Temperature, T <sub>j</sub>	125°C
Digital core and analog supply voltage to ground potential (VDDC and AVDD)	-0.3v to 1.2v
Digital I/O and analog high supply voltage to ground potential (VDDR and AVDDH)	-0.3v to 3.8v
Reference Clock supply voltage to ground potential (CVDDR)	-0.3v to 3.8v
DC input voltage for Digital I/O signals	-0.3v to 3.8v
ESD Rating	
Human Body Model (JEDEC Class 2)	2kv
Charge Device Model (JEDEC Class 3)	500v

**Note:**

Stresses greater than those listed under MAXIMUM RATINGS may cause permanent damage to the device. This is a stress rating only and functional operation of the device at these or any conditions above those indicated in the operational sections of this specification is not implied. Exposure to absolute maximum rating conditions for extended periods of time may affect reliability.

### 11.2 DC SPECIFICATIONS

Table 11-2 DC Electrical Characteristics

Symbol	Description	Min.	Typ.	Max.	Unit
VDDC	Digital Core Power	0.95	1.0	1.1	V
VDDR	Digital I/O Power	3.0	3.3	3.6	
CVDDR	Reference Clock Power	3.0	3.3	3.6	
AVDD	PCI Express Analog Power	0.95	1.0	1.1	
AVDDH	PCI Express Analog High Voltage Power	3.0	3.3	3.6	
V <sub>IH</sub>	Input High Voltage	2.0		5.5	
V <sub>IL</sub>	Input Low Voltage	-0.3		0.8	
V <sub>OH</sub>	Output High Voltage	2.4	-	-	
V <sub>OL</sub>	Output Low Voltage	-	-	0.4	
R <sub>PU</sub>	Pull-up Resistor	63K	92K	142K	
R <sub>PD</sub>	Pull-down Resistor	57K	91K	159K	
RST# <sub>slew</sub> <sup>1</sup>	PERST_L Slew Rate	50			mV/ns

**Note:**

- The min. value for PERST\_L Slew Rate is 50 mV/ns, which translates to the requirement that the time for PERST\_L from 0V to 3.3V should be less than 66 ns.

### 11.3 AC SPECIFICATIONS

Table 11-3 PCI Express Interface - Differential Transmitter (TX) Output (5.0 Gbps) Characteristics

Parameter	Symbol	Min	Typ	Max	Unit
Unit Interval	UI	199.94	200.0	200.06	ps
Differential p-p TX voltage swing	V <sub>TX-DIFF-P-P</sub>	800	-	-	mV ppd
Low power differential p-p TX voltage swing	V <sub>TX-DIFF-P-P-LOW</sub>	400	-	-	mV ppd
TX de-emphasis level ratio	V <sub>TX-DE-RATIO-3.5dB</sub>	-3.0	-	-4.0	dB

Parameter	Symbol	Min	Typ	Max	Unit
TX de-emphasis level ratio	$V_{TX-DE-RATIO-6dB}$	-5.5	-	-6.5	dB
Transmitter Eye including all jitter sources	$T_{TX-EYE}$	0.75	-	-	UI
TX deterministic jitter > 1.5 MHz	$T_{TX-HF-DJ-DD}$	-	-	0.15	UI
TX RMS jitter < 1.5 MHz	$T_{TX-LF-RMS}$	-	-	3.0	Ps RMS
Transmitter rise and fall time	$T_{TX-RISE-FALL}$	0.15	-	-	UI
TX rise/fall mismatch	$T_{RF-MISMATCH}$	-	-	0.1	UI
Maximum TX PLL Bandwidth	$BW_{TX-PLL}$	-	-	16	MHz
Minimum TX PLL BW for 3dB peaking	$BW_{TX-PLL-LO-3DB}$	8	-	-	MHz
TX PLL peaking with 8 MHz min BW	$PKG_{TX-PLLI}$	-	-	3.0	dB
DC Differential TX Impedance	$Z_{TX-DIFF-DC}$	80	-	120	$\Omega$
Transmitter Short-Circuit Current Limit	$I_{TX-SHORT}$	-	-	90	mA
TX DC Common Mode Voltage	$V_{TX-DC-CM}$	0	-	3.6	V
Absolute Delta of DC Common Mode Voltage During L0 and Electrical Idle	$V_{TX-CM-DC-ACTIVE-IDLE-DELTA}$	0	-	100	mV
Absolute Delta of DC Common Mode Voltage between D+ and D-	$V_{TX-CM-DC-LINE-DELTA}$	0	-	25	mV
Electrical Idle Differential Peak Output Voltage	$V_{TX-IDLE-DIFF-AC-P}$	0	-	20	mV
DC Electrical Idle Differential Output Voltage	$V_{TX-IDLE-DIFF-DC}$	0	-	5	mV
The Amount of Voltage Change Allowed During Receiver Detection	$V_{TX-RCV-DETECT}$	-	-	600	mV
Lane-to-Lane Output Skew	$L_{TX-SKEW}$	-	-	500 ps + 4 UI	ps

**Table 11-4 PCI Express Interface - Differential Transmitter (TX) Output (2.5 Gbps) Characteristics**

Parameter	Symbol	Min	Typ	Max	Unit
Unit Interval	UI	399.88	400.0	400.12	ps
Differential p-p TX voltage swing	$V_{TX-DIFF-P-P}$	800	-	-	mV ppd
Low power differential p-p TX voltage swing	$V_{TX-DIFF-P-P-LOW}$	400	-	-	mV ppd
TX de-emphasis level ratio	$V_{TX-DE-RATIO}$	-3.0	-	-4.0	dB
Minimum TX eye width	$T_{TX-EYE}$	0.75	-	-	UI
Maximum time between the jitter median and max deviation from the median	$T_{TX-EYE-MEDIAN-to-MAX-JITTER}$	-	-	0.125	UI
Transmitter rise and fall time	$T_{TX-RISE-FALL}$	0.125	-	-	UI
Maximum TX PLL Bandwidth	$BW_{TX-PLL}$	-	-	22	MHz
Maximum TX PLL BW for 3dB peaking	$BW_{TX-PLL-LO-3DB}$	1.5	-	-	MHz
Absolute Delta of DC Common Mode Voltage During L0 and Electrical Idle	$V_{TX-CM-DC-ACTIVE-IDLE-DELTA}$	0	-	100	mV
Absolute Delta of DC Common Mode Voltage between D+ and D-	$V_{TX-CM-DC-LINE-DELTA}$	0	-	25	mV
Electrical Idle Differential Peak Output Voltage	$V_{TX-IDLE-DIFF-AC-P}$	0	-	20	mV
The Amount of Voltage Change Allowed During Receiver Detection	$V_{TX-RCV-DETECT}$	-	-	600	mV
Transmitter DC Common Mode Voltage	$V_{TX-DC-CM}$	0	-	3.6	V
Transmitter Short-Circuit Current Limit	$I_{TX-SHORT}$	-	-	90	mA
DC Differential TX Impedance	$Z_{TX-DIFF-DC}$	80	100	120	$\Omega$
Lane-to-Lane Output Skew	$L_{TX-SKEW}$	-	-	500 ps + 2 UI	ps

**Table 11-5 PCI Express Interface - Differential Receiver (RX) Input (5.0 Gbps) Characteristics**

Parameter	Symbol	Min	Typ	Max	Unit
Unit Interval	UI	199.94	200.0	200.06	ps
Differential RX Peak-to-Peak Voltage	$V_{RX-DIFF-PP-CC}$	120	-	1200	mV
Total jitter tolerance	$T_{JRX}$	0.68	-	-	UI
Receiver DC common mode impedance	$Z_{RX-DC}$	40	-	60	$\Omega$
RX AC Common Mode Voltage	$V_{RX-CM-AC-P}$	-	-	150	mV
Electrical Idle Detect Threshold	$V_{RX-IDLE-DET-DIFF-P}$	65	-	175	mV

**Table 11-6 PCI Express Interface - Differential Receiver (RX) Input (2.5 Gbps) Characteristics**

Parameter	Symbol	Min	Typ	Max	Unit
Unit Interval	UI	399.88	400.0	400.12	ps
Differential RX Peak-to-Peak Voltage	$V_{RX-DIFF-PP-CC}$	175	-	1200	mV
Receiver eye time opening	$T_{RX-EYE}$	0.4	-	-	UI
Maximum time delta between median and deviation from median	$T_{RX-EYE-MEDIAN-to-MAX-JITTER}$	-	-	0.3	UI
Receiver DC common mode impedance	$Z_{RX-DC}$	40	-	60	$\Omega$
DC differential impedance	$Z_{RX-DIFF-DC}$	80	-	120	$\Omega$
RX AC Common Mode Voltage	$V_{RX-CM-AC-P}$	-	-	150	mV
DC input CM input impedance during reset or power down	$Z_{RX-HIGH-IMP-DC}$	200	-	-	k $\Omega$
Electrical Idle Detect Threshold	$V_{RX-IDLE-DET-DIFF-P}$	65	-	175	mV
Lane to Lane skew	$L_{RX-SKEW}$	-	-	20	ns

## 11.4 POWER CONSUMPTION

**Table 11-7 Power Consumption**

Active Lane per Port	1.0VDDC		1.0VAVDD		3.3AVDDH		3.3VDDR		3.3CVDDR		Total		Unit
	Typ	Max	Typ	Max	Typ	Max	Typ	Max	Typ	Max	Typ	Max	
4/2/2	308.0	564.3	92.4	810.7	92.4	101.6	6.6	7.3	396.0	435.6	895.4	1,919.5	mW

**Test Conditions:**

- Typical power measured under the conditions of 1.0V/ 3.3V power rail without device usage on all downstream ports.
- Maximum power measured under the conditions of 1.1V/ 3.63V with PCIe2 devices usage on all downstream ports
- Ambient Temperature at 25°C
- Power consumption in the table is a reference, be affected by various environment, bus traffic and power supply etc.

## 11.5 OPERATING AMBIENT TEMPERATURE

**Table 11-8 Operating Ambient Temperature**

(The condition of Operating Ambient Temperature be associated with Chapter 12.)

Item	Low	High	Unit
Ambient Temperature with power applied	-40	85	°C

**Note:**

Exposure to high temperature conditions for extended periods of time may affect reliability.

## 12 THERMAL DATA

The information described in this section is provided for reference only.

**Table 12-1 Thermal Data**

Power (Watt)	T <sub>a</sub> (°C)	JEDEC Board	Airflow (m/s)	Θ <sub>JA</sub> (°C/W)	T <sub>j</sub> (°C)	Θ <sub>JC</sub> (°C/W)
1.8	85	4-Layer	0	26.65	132.97	8.96
			1	23.71	127.68	
			2	22.57	125.63	
		8-Layer	0	17.75	116.95	8.44
			1	16.65	114.97	
			2	16.33	114.39	

**Note:**

1. T<sub>a</sub>: Ambient Temperature
2. T<sub>j</sub>: Junction Temperature
3. Maximum allowable junction temperature = 125°C
4. Θ<sub>JA</sub>: Thermal Resistance, Junction-to-Ambient
5. Θ<sub>JC</sub>: Thermal Resistance, Junction-to-Case
6. Power measured under the conditions of 1.0V/ 3.3V with PCIe2 devices usage on all downstream ports
7. The shaded fields provide a recommendation that allows PI7C9X2G308GP to support Industrial Temperature Range.



### 13 PACKAGE INFORMATION

The package of PI7C9X2G308GP is a 15mm x 15mm LBGGA (196 Pin) package with ball pitch 1.0mm. The detailed package information, mechanical dimension and package of drawing are shown below.

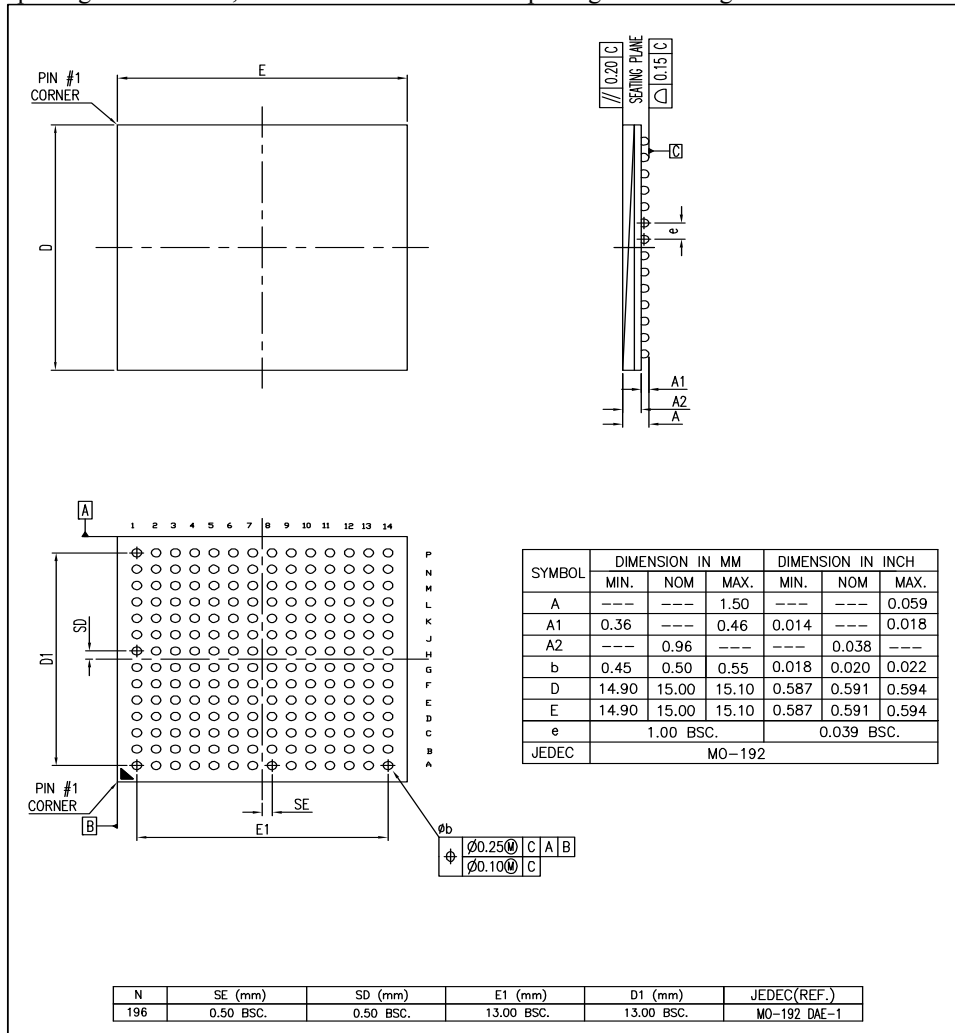

Figure 13-1 Package of Drawing



YY: Year  
 WW: Workweek  
 1st X: Assembly Code  
 2nd X: Fab Code  
 Bar above fab code means Cu wire  
 Bar above assy code means ULA BOM

Figure 13-2 Part Marking

## 14 ORDERING INFORMATION

Part Number	Temperature Range	Package	Pb-Free & Green
PI7C9X2G308GPBNJEX	-40° to 85°C (Industrial Temperature)	196-pin LBGGA 15mm x 15mm	Yes

**Notes:**

1. No purposely added lead. Fully EU Directive 2002/95/EC (RoHS), 2011/65/EU (RoHS 2) & 2015/863/EU (RoHS 3) compliant.
2. See <https://www.diodes.com/quality/lead-free/> for more information about Diodes Incorporated's definitions of Halogen- and Antimony-free, "Green" and Lead-free.
3. Halogen- and Antimony-free "Green" products are defined as those which contain <900ppm bromine, <900ppm chlorine (<1500ppm total Br + Cl) and <1000ppm antimony compounds.

