

REV.	ECN NO.	DATE	SIGN	DESCRIPTION
B	LEN15A0358	2015/09/16	Mila	Product improve

ALTW
CONFIDENTIAL
2015-09-16
R&D DEPT.

ALTW
DCC. DEPT.
CONFIDENTIAL
2015.10.21
ISSUED

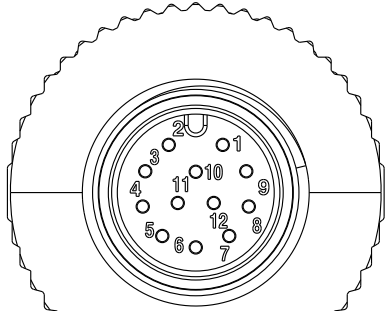
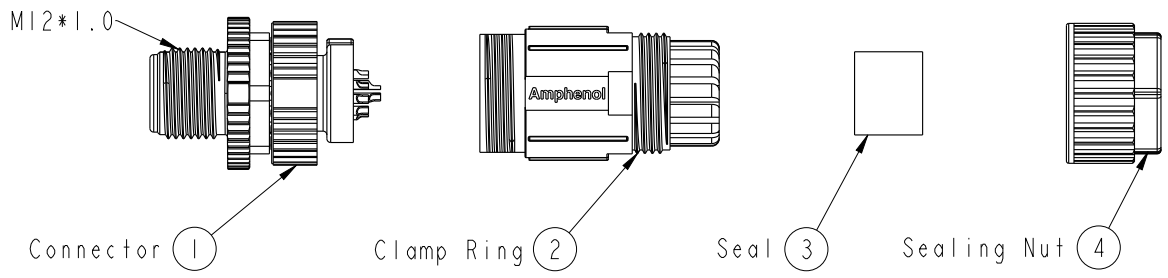

Pin Assignments
Front View

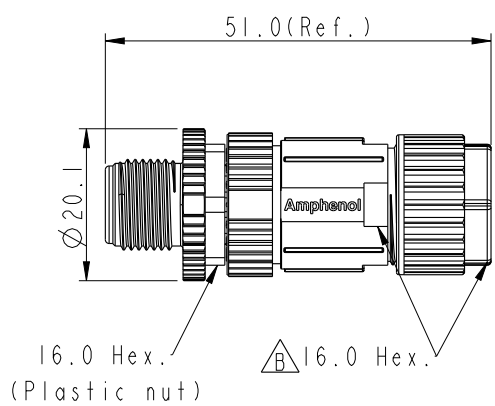
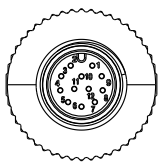

- Note:
- * CC Important Dimension To Check.
 - * Waterproof Rate: IP67
 - * Housing: Nylon, Black.
 - * Male Pin: Copper Alloy, Gold Plated.
 - * Male Nut: PBT+PC, Black.
 - * O-Ring: Silicon, Grey.
 - * Clamp Ring: Nylon, Black.
 - * Sealing Nut: PBT+PC, Black.
 - * Seal: Silicon, Grey.
 - * Seal For Cable OD: $\varnothing 4.0\text{mm} \sim \varnothing 8.0\text{mm}$
 - * Applicable Wire gauge (Stranded wire cross section) 26AWG~24AWG
 - * Mating Recommended tightening torque: 3~4 kgf.cm / 0.29~0.39 N.m
 - * Sealing-Nut Recommended tightening torque: 4~6 kgf.cm / 0.39~0.59 N.m
 - * Detailed applicable wire specifications may vary depending on the actual wire construction.

UNIT:mm		
TOLERANCE	.X ±0.25	
.XX ±0.1		
.XXX ±0.05		
ANGLES	±1°	

TITLE M12A Unshielded Assy 12Pin M Conn. M Pin			
SCALE 1:1	SIZE A4	SHEET 1 OF 1	
REV. B	WC-REV. A.2	CC : Inspection item	

Amphenol LTW
安費諾亮泰企業股份有限公司

ITEM NO. MSAP-12BMMA-SL7001	DRAWN BY Mila	DATE 2015-09-16
DWG NO. MSAP-12BMMA-SL7001	CHECKED BY Cary	DATE 2015-09-16
CUSTOMER ALTW	APPROVED BY Jerry	DATE 2015-09-16

THIS DOCUMENT IS SUBJECT TO CHANGE WITHOUT NOTICE. IT IS CONFIDENTIAL AND A PROPERTY OF Amphenol LTW. DISCLOSURE TO THIRD PARTY HAS TO BE AUTHORIZED BY Amphenol LTW.