

HIGH PRESSURE CONNECTORS W SERIES



Precision modular connectors to suit your application

Since its creation in Switzerland in 1946 the LEMO Group has been recognized as a global leader of circular Push-Pull connectors and connector solutions. Today LEMO and its affiliated companies, REDEL and COELVER, are active in more than 80 countries with the help of over 40 subsidiaries and distributors.

Over 75000 connectors

The modular design of the LEMO range provides over 75000 connectors from miniature \varnothing 3 mm to \varnothing 50 mm, capable of handling cable diameters up to 30 mm and for up to 114 contacts. This vast portfolio enables you to select the ideal connector configuration to suit almost any specific requirement in most markets, including medical devices, test and measurement instruments, machinery, audio video broadcast, telecommunications and military.

LEMO's Push-Pull Self-Latching Connection System (not shown in this catalogue)

This self-latching system is renowned worldwide for its easy and quick mating and unmating features. It provides absolute security against vibration, shock or pull on the cable, and facilitates operation in a very limited space.

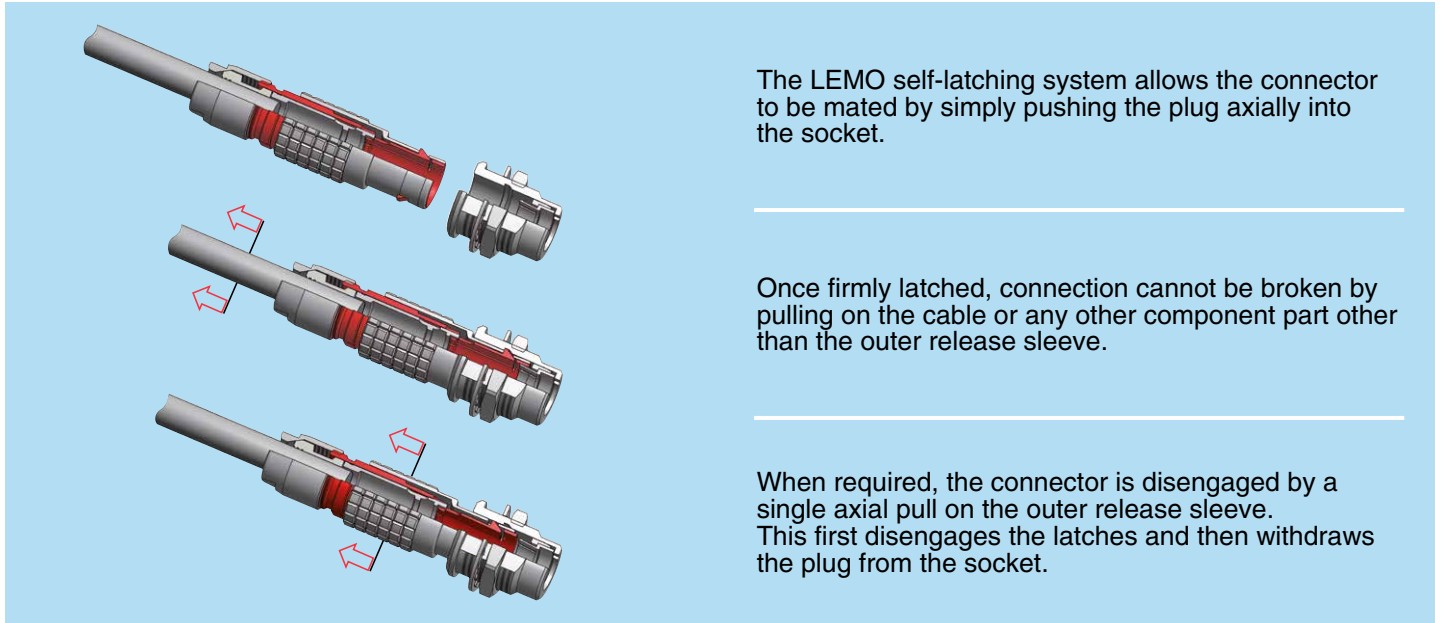

The LEMO self-latching system allows the connector to be mated by simply pushing the plug axially into the socket.



Once firmly latched, connection cannot be broken by pulling on the cable or any other component part other than the outer release sleeve.

When required, the connector is disengaged by a single axial pull on the outer release sleeve. This first disengages the latches and then withdraws the plug from the socket.

UL Recognition

LEMO connectors are recognized by the Underwriters Laboratories (UL). The approval of the complete system (LEMO connector, cable and your equipment) will be easier because LEMO connectors are recognized.

CE marking

CE marking  means that the appliance or equipment bearing it complies with the protection requirements of one or several European safety directives. CE marking  applies to complete products or equipment, **but not to electromechanical components, such as connectors.**

RoHS

LEMO connector specifications conforms the requirements of the RoHS directive (2011/65/EU) of the European Parliament and the latest amendments. This directive specifies the restrictions of the use of hazardous substances in electrical and electronic equipment marketed in Europe.

Product safety notice & disclaimers

Please read and follow all instructions specified on the last page or on our [website](#) carefully and consult all relevant national and international safety regulations for your application. Improper handling, cable assembly, or wrong use of connectors can result in hazardous situations.

LEMO products and services are provided "as is." LEMO makes no warranties or representations with regard to LEMO product & services or use of them, express, implied or statutory, including for accuracy, completeness, or security.

In no event shall LEMO be liable for any direct, indirect, punitive, incidental, special consequential damages, to property or life, whatsoever arising out of or connected with the use or misuse of LEMO's products.

W Series

W Series connectors have been developed for utilisation where protection must be guaranteed under high pressures of liquids. The basic elements, insulators, contacts and clamping system are from the B series. The push-pull latching system has been replaced by a screw coupling system with watertightness maintained by compression of an O-ring in FPM (Viton®) according to the triangular shaped cavity principle. There are multiple application possibilities ranging from nuclear physics to the petroleum industry. After cable assembly, the rear part must be covered by an adhesive heatshrink boot in order to ensure watertightness on the cable side. W series connectors provide the following main features:

- multipole types from 2 to 64 contacts
- fibre optic or mixed types available upon request
- solder or crimp contacts
- keying system («G» key standard) for connector alignment
- multiple key options to avoid cross mating of similar connectors
- 360° screening for full EMC shielding
- rugged housing for extreme working conditions.

Interconnections

Models (page 3)

Straight plugs

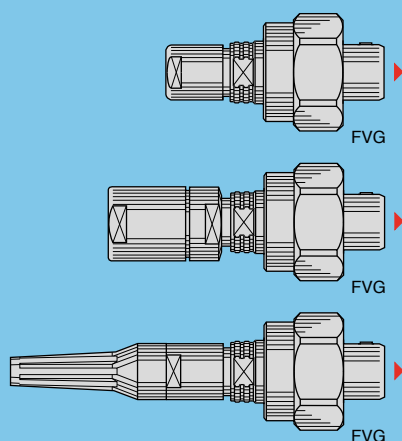

Fixed socket

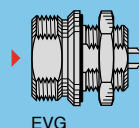

Free sockets

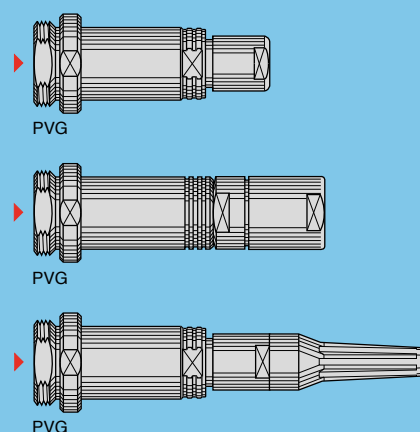

Vacuumtight models (page 6)

Fixed sockets

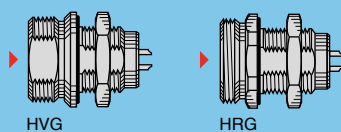

Part Section Showing Internal Components

Fixed socket

- 1 outer shell
- 2 earthing crown
- 3 retaining ring
- 4 hexagonal nut
- 5 insulator
- 6 female contact
- 7 O-ring

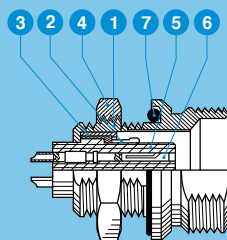

Straight plug

- 1 outer shell
- 2 coupling nut
- 3 circlip
- 4 collet nut
- 5 split insert carrier
- 6 o-ring
- 7 insulator
- 8 male contact
- 9 earthing cone
- 10 collet + washer ¹⁾
- 11 gasket

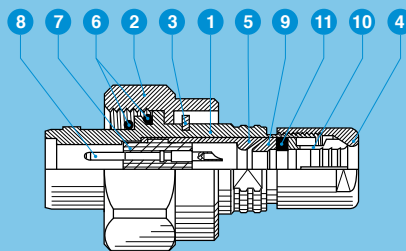

Note: ¹⁾ depending on models.

Part Number Example

Straight plug with cable collet

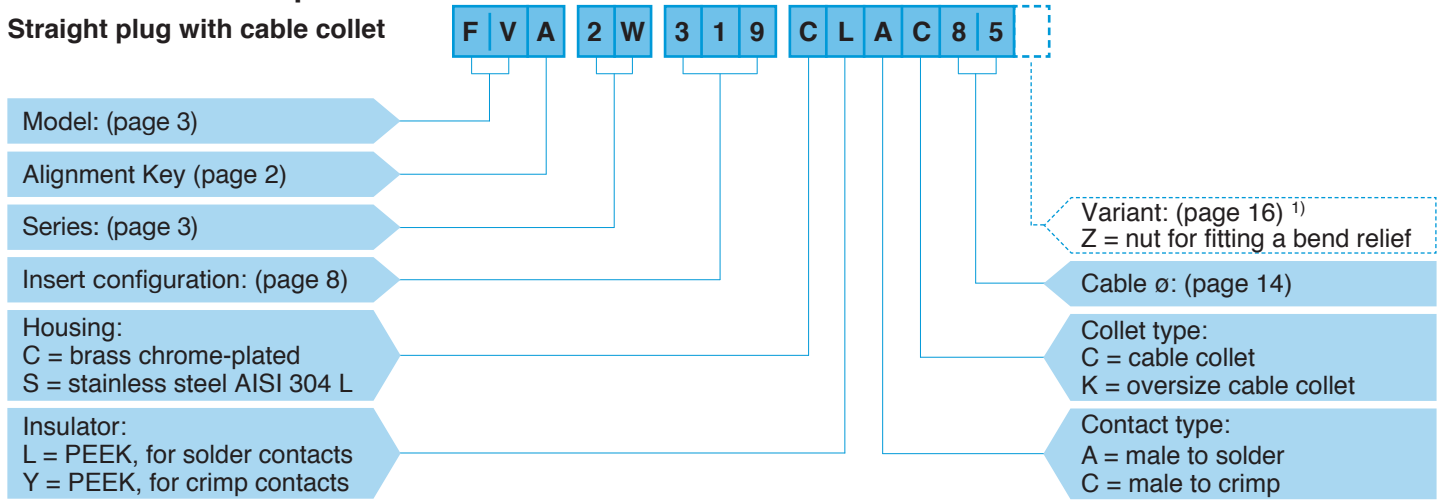

FVA.2W.319.CLAC85 = straight plug with key (A), 2W series, multipole type with 19 contacts, outer shell in chrome-plated brass, PEEK insulator, male solder contacts, C type collet for 8.5 mm diameter cable.

Fixed socket, vacuumtight

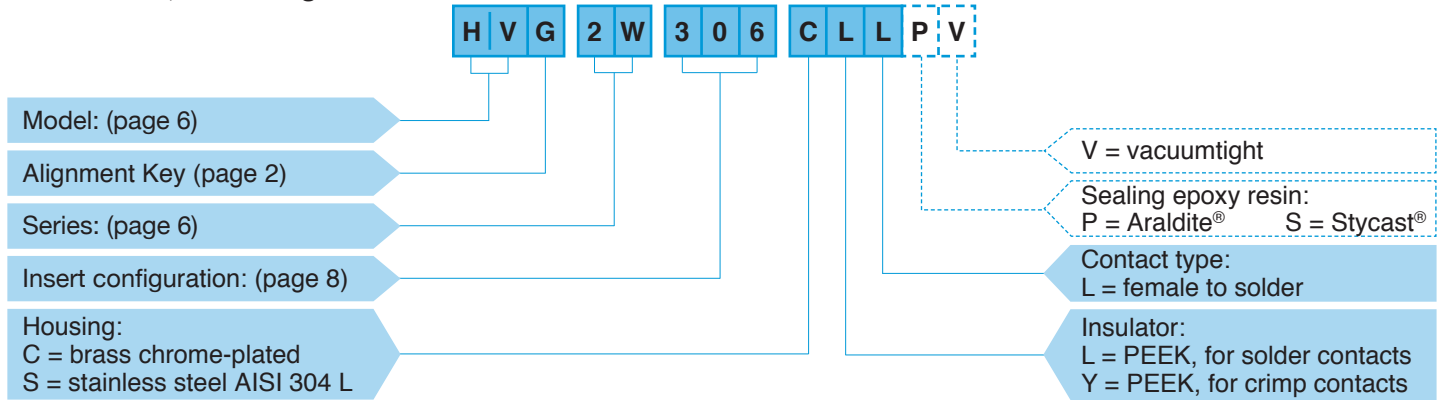

HVG.2W.306.CLLPV = fixed socket, nut fixing, key (G), 2W series, multipole type with 6 contacts, outer shell in chrome-plated brass, PEEK insulator, female solder contacts, potted with Araldite[®] epoxy resin, vacuumtight.

Note: ¹⁾ The «Variant» position in the reference is used to specify either the presence of a collet nut for fitting the bend relief. For models with collet nut for fitting the bend relief, a «Z» should be indicated and a bend relief can be ordered separately. An order for a connector with bend relief should thus include two part numbers.



Alignment Key and Polarized Keying System

W series connector model part numbers are composed of three letters. The LAST LETTER indicates the key position and the contact type (male or female).

Front view of a socket 	Ref.	Nb of keys	Angles	Series	Contact type		Note
				0W-5W	Plug	Socket	
	G	1		0°	male	female	●
	A	2	α	30°	male	female	●
	B	2	α	45°	male	female	●
	L	2	γ	75°	female	male	○

● Available
○ On request



Models

Technical Characteristics

Mechanical and Climatical

Characteristics	Value	Standard
Endurance	> 1000 cycles	IEC 60512-5 test 9a
Temperature range	-20° C, +200° C	
Salt spray corrosion test ²⁾	> 1000 h	IEC 60512-6 test 11f
Protection index (mated)	> IP 68	IEC 60529
Resistance to hydrostatic pressure (mated)	~ 30 bars ¹⁾	IEC 60512-7 test 14d
Climatical category	20/200/21	IEC 60068-1

Electrical

Characteristics	Value	Standard
Shielding efficiency	at 10 MHz	> 95 dB
	at 1 GHz	> 80 dB

Note:

¹⁾ in order to perform correctly and withstand the pressure, cable assembly shall be made according to instruction we recommend. See page 19.

²⁾ for chrome plated product («C» material code).

FVG Straight plug, key (G) or keys (A, B or L), cable collet

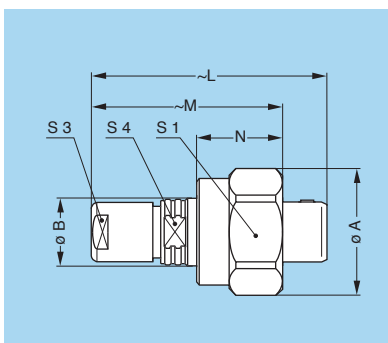

Reference		Dimensions (mm)							
Model	Series	A	B	L	M	N	S1	S3	S4
FVG	0W	17.2	10.0	36.0	30.8	13.5	16	8	8
FVG	1W	19.3	12.0	43.2	35.1	14.0	18	9	10
FVG	2W	23.5	16.0	52.5	43.0	15.5	22	12	13
FVG	3W	27.8	17.0	61.5	48.0	16.5	26	15	–
FVG	4W	34.3	22.0	71.5	57.5	17.5	32	19	–
FVG	5W	50.0	34.0	100.0	83.0	21.0	47	30	–

FVG Straight plug, key (G) or keys (A, B or L), oversize cable collet ¹⁾

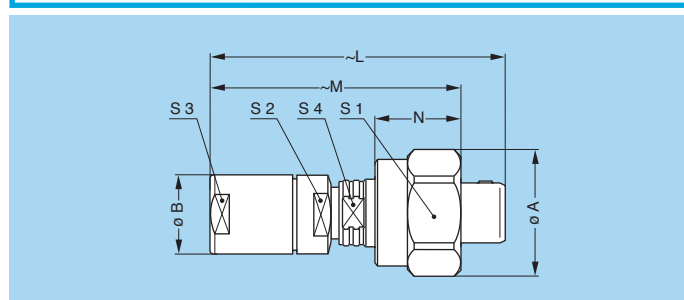

Reference		Dimensions (mm)								
Model	Series	A	B	L	M	N	S1	S2	S3	S4
FVG	1W	19.3	14.5	56.5	48.3	14.0	18	12	12	10
FVG	2W	23.5	17.0	68.5	56.0	15.5	22	15	15	13
FVG	3W	27.8	22.0	80.5	67.0	16.5	26	19	19	–
FVG	4W	34.3	36.0	105.5	91.5	17.5	32	30	32	–

Note: ¹⁾ correspond to K type of collet, the fitting of oversize collets onto this model allows them to be fitted to the cables that can be accommodated by the next housing size up (see page 14).

FVG Straight plug, key (G) or keys (A, B or L), cable collet and nut for fitting a bend relief ¹⁾

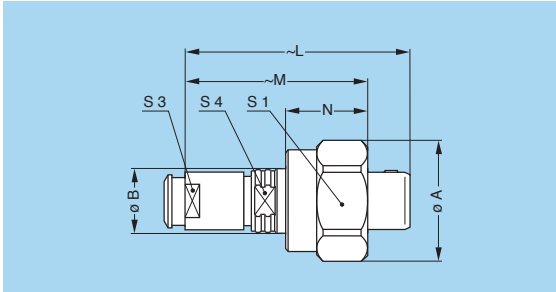
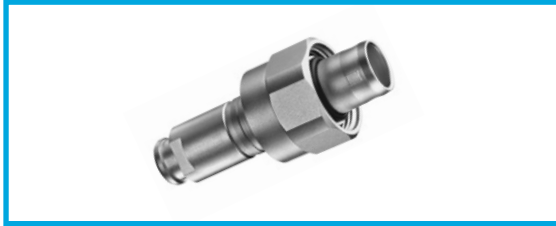

Reference		Dimensions (mm)							
Model	Series	A	B	L	M	N	S1	S3	S4
FVG	0W	17.2	10.0	36.0	30.8	13.5	16	7	8
FVG	1W	19.3	12.0	43.2	35.1	14.0	18	9	10
FVG	2W	23.5	16.0	52.5	43.0	15.5	22	12	13
FVG	3W	27.8	17.0	60.5	46.9	16.5	26	15	–
FVG	4W	34.3	22.0	71.5	57.5	17.5	32	19	–

Note: ¹⁾ to order, add a «Z» at the end of the reference. The bend relief must be ordered separately (see pages 141 and 142 of the unipole/multipole catalog).

FVG Straight plug, key (G) or keys (A, B or L), cable collet with special coupling nut ¹⁾

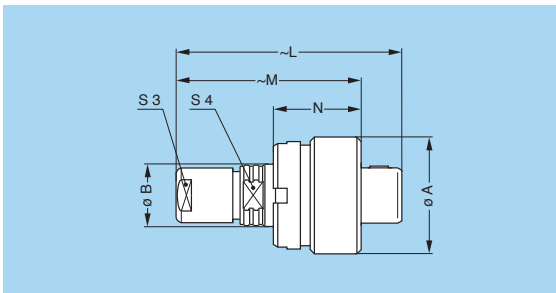

Reference		Dimensions (mm)						
Model	Series	A	B	L	M	N	S3	S4
FVG	0W	17	8.9	36.0	29.8	13.5	8	8

Note: ¹⁾ to order, add a «Y» at the end of the reference.

EVG Fixed socket, nut fixing, key (G) or keys (A, B or L)

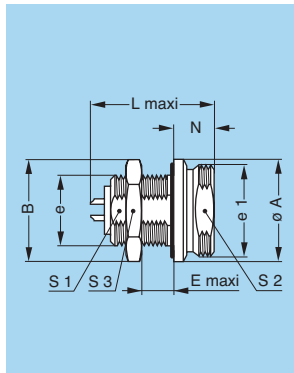

Reference		Dimensions (mm)									
Model	Series	A	B	e	e1	E	L	N	S1	S2	S3
EVG	0W	16.2	16.0	M12x1.0	M14x1.0	4.0	21.7	8.0	10.5	12.5	14
EVG	1W	18.3	19.5	M14x1.0	M16x1.0	8.0	27.0	8.0	12.5	14.5	17
EVG	2W	22.5	21.8	M16x1.0	M20x1.0	9.0	30.7	9.0	14.5	18.5	19
EVG	3W	26.6	27.0	M20x1.0	M24x1.0	13.0	36.2	9.5	18.5	22.5	24
EVG	4W	32.8	34.2	M24x1.0	M30x1.0	15.0	40.2	9.5	22.5	28.5	30
EVG	5W	48.0	53.0	M38x1.5	M45x1.5	18.0	47.5	12.5	35.5	42.5	46

Panel cut-out (page 18)



PVG Free socket, key (G) or keys (A, B or L), cable collet

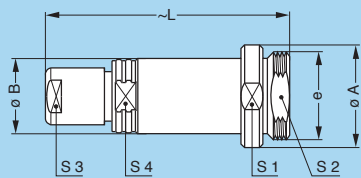

Reference		Dimensions (mm)							
Model	Series	A	B	e	L	S1	S2	S3	S4
PVG	0W	–	8.9	M14x1.0	37.9	–	13.5	8	8
PVG	1W	18.3	11.0	M16x1.0	45.0	16	14.5	9	–
PVG	2W	22.5	14.0	M20x1.0	54.0	20	18.5	12	–
PVG	3W	26.6	17.0	M24x1.0	65.0	24	22.5	15	–
PVG	4W	32.8	22.0	M30x1.0	75.5	30	28.5	19	–
PVG	5W	48.0	34.0	M45X1.5	103.0	45	42.5	30	–

PVG Free socket, key (G) or keys (A, B or L), oversize cable collet ¹⁾

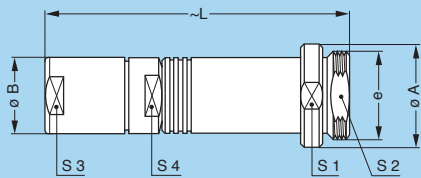

Reference		Dimensions (mm)							
Model	Series	A	B	e	L	S1	S2	S3	S4
PVG	1W	18.3	14.0	M16x1.0	58.0	16	14.5	12	12
PVG	2W	22.5	17.0	M20x1.0	67.0	20	18.5	15	15
PVG	3W	26.6	22.0	M24x1.0	84.0	24	22.5	19	19
PVG	4W	32.8	34.0	M30x1.0	109.5	30	28.5	32	30

Note: ¹⁾ correspond to K type of collet, the fitting of oversize collets onto this model allows them to be fitted to the cables that can be accommodated by the next housing size up (see page 14).

PVG Free socket, key (G) or keys (A, B or L), cable collet and nut for fitting a bend relief ¹⁾

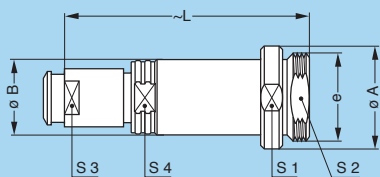
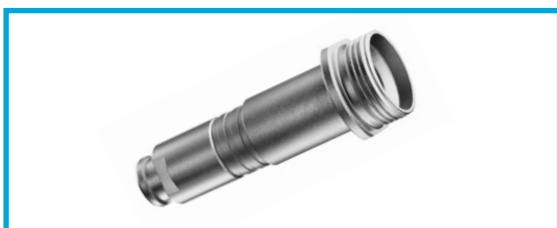

Reference		Dimensions (mm)							
Model	Series	A	B	e	L	S1	S2	S3	S4
PVG	0W	–	8.9	M14x1.0	37.9	–	13.5	7	8
PVG	1W	18.3	11.0	M16x1.0	45.0	16	14.5	9	–
PVG	2W	22.5	14.0	M20x1.0	54.0	20	18.5	12	–
PVG	3W	26.6	17.0	M24x1.0	64.0	24	22.5	15	–
PVG	4W	32.8	22.0	M30x1.0	75.5	30	28.5	19	–

Note: ¹⁾ to order, add a «Z» at the end of the reference. The bend relief must be ordered separately (see pages 141 and 142 of the unipole/multipole catalog).

Vacuumtight models

HRG and HVG socket models allow the device on which they are fitted to reach a protection index of IP68 as per IEC 60529. They are fully compatible with plugs of the same series and are widely used for portable radios, military, laboratory equipment, aviation, etc. These models are made in a vacuumtight version. They are identified by an additional letter «V» at the end of the part number (certificate on request).

Epoxy resin is used to seal these models and we are offering 2 different resins:

- a) Epoxy Araldite®, for general purpose use, identify with letter «P»
- b) Epoxy Stycast®, for oil and petrol industry, identify with the letter «S».

Part number example:

Vacuumtight socket potted with Araldite® epoxy: HVG.0W.304.CLLPV
 Vacuumtight socket potted with Stycast® epoxy: HVG.0W.304.CLLSV

Technical Characteristics

Mechanical and Climatical

Characteristics	Value	Standard
Endurance	> 1000 cycles	IEC 60512-5 test 9a
Humidity	up to 95% at 60° C	
Temperature range (0W-1W)	- 20° C/+100° C	
Temperature range (2W to 5W)	- 20° C/+80° C	
Salt spray corrosion test ³⁾	> 1000 h	IEC 60512-6 test 11f
Climatical category	20/80/21	IEC 60068-1
Leakage rate (He) ¹⁾	< 10 ⁻⁷ mbar.l.s ⁻¹	IEC 60512-7 test 14b

Characteristics	Value	Standard
Maximum operating pressure ²⁾	0W	60 bars IEC 60512-7 test 14d
	1W	60 bars IEC 60512-7 test 14d
	2W	40 bars IEC 60512-7 test 14d
	3W	30 bars IEC 60512-7 test 14d
	4W	15 bars IEC 60512-7 test 14d
	5W	5 bars IEC 60512-7 test 14d

Note:

- ¹⁾ for vacuumtight models.
- ²⁾ this value corresponds to the maximum allowed pressure difference for the assembled socket if used in the unmated condition.
- ³⁾ for chrome plated product («C» material code).

HVG Fixed socket, nut fixing, key (G) or keys (A, B or L), vacuumtight

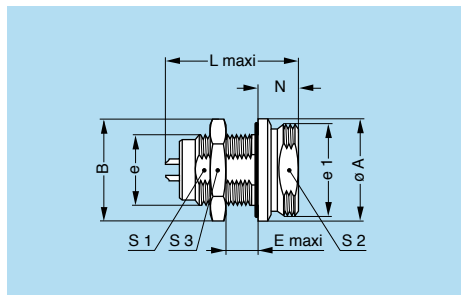

Reference		Dimensions (mm)									
Model	Series	A	B	e	e1	E	L	N	S1	S2	S3
HVG	0W	16.2	16.0	M12x1.0	M14x1.0	5.5	24.1	8.0	10.5	12.5	14
HVG	1W	18.3	19.5	M14x1.0	M16x1.0	11.5	30.0	8.0	12.5	14.5	17
HVG	2W	22.5	21.8	M16x1.0	M20x1.0	14.5	35.8	9.0	14.5	18.5	19
HVG	3W	26.6	27.0	M20x1.0	M24x1.0	17.5	42.2	9.5	18.5	22.5	24
HVG	4W	32.8	34.2	M24x1.0	M30x1.0	20.0	48.2	9.5	22.5	28.5	30
HVG	5W	48.0	53.0	M38x1.5	M45x1.5	22.0	55.6	12.5	35.5	42.5	46

Panel cut-out (page 18)

HRG Fixed socket, nut fixing, key (G) or keys (A, B or L), hexagonal flange, vacuumtight

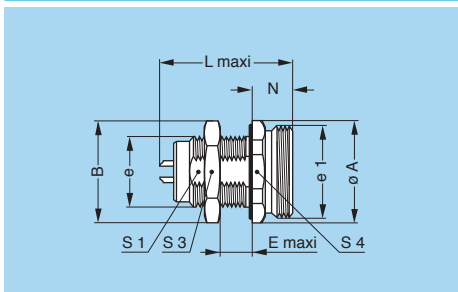

Reference		Dimensions (mm)									
Model	Series	A	B	e	e1	E	L	N	S1	S3	S4
HRG	OW	18	16	M12x1.0	M14x1.0	5.5	24.1	8	10.5	14	17

Panel cut-out (page 18)

Insert configuration

Other like fibre optic or mixed are available, please consult us.

Multipole

	Solder contacts		Reference	Series	Contact ø (mm)	Contact type				AWG			Solder contact		Rated current (A) ¹⁾
						Solder	Crimp	Print (straight)	Print (elbow)	Solder (max.)	Crimp		Test voltage (kV rms) ¹⁾ Contact-contact	Test voltage (kV rms) ¹⁾ Contact-shell	
											min.	max.			
2			302	0W	0.9	●	●	●	●	20	32	20	1.00	1.05	10.0 ²⁾
				1W	1.3	●	●	●	●	20	26	18	1.50	1.35	15.0 ³⁾
				2W	2.0	●	●	●	●	16	18	12	2.10	1.75	25.0 ³⁾
				3W	3.0	●	●	○		12	14	10	2.10	1.55	35.0
				5W	6.0	●				8			3.60	2.95	50.0
3			303	0W	0.9	●	●	●	●	20	32	20	1.20	0.90	8.0 ²⁾
				1W	1.3	●	●	●	●	20	26	18	1.30	1.55	12.0
				2W	1.6	●	●	●	●	18	22	14	2.40	1.85	17.0 ³⁾
				3W	2.0	●	●	●	○	16	18	12	1.90	1.50	25.0
4			304	0W	0.7	●	●	●	●	22	32	22	0.85	0.70	7.0 ²⁾
				1W	0.9	●	●	●	●	22	32	20	1.35	1.45	10.0 ²⁾
				2W	1.3	●	●	●	●	20	26	18	1.85	1.85	15.0 ³⁾
				3W	2.0	●	●	●	●	16	18	12	1.45	1.25	19.0
				4W	3.0	●	●	○		12	14	10	2.10	1.50	30.0
				5W	4.0	●	●	○		10	12	10	2.95	2.65	35.0
5			305	0W	0.7	●	●	●	●	22	32	22	1.00	0.70	6.5 ²⁾
				1W	0.9	●	●	●	●	22	32	20	1.25	1.15	9.0 ²⁾
				2W	1.3	●	●	●	●	20	26	18	1.75	1.60	14.0 ³⁾
				3W	1.6	●	●	●	○	18	22	14	1.90	1.25	19.0
6			306	0W	0.5	●	○ ⁴⁾	●	●	28	32	28	0.85	0.65	2.5
				1W	0.7	●	●	●	●	22	32	22	1.05	1.20	7.0 ²⁾

- First choice alternative
- Special order alternative

Note: ¹⁾ see calculation method, caution and suggested standard.
²⁾ rated current = 6A for socket with elbow (90°) contact for printed circuit.
³⁾ rated current = 12A for socket with elbow (90°) contact for printed circuit.
⁴⁾ available only for connectors fitted with male contacts.



Multipole

	Solder contacts		Reference	Series	Contact ø (mm)	Contact type				AWG		Solder contact		Rated current (A) ¹⁾	
	Crimp contacts					Solder	Crimp	Print (straight)	Print (elbow)	Solder (max.)	Crimp		Test voltage (kV rms) ¹⁾ Contact-contact		Test voltage (kV rms) ¹⁾ Contact-shell
	min.	max.													
6			306	2W	1.3	●	●	●	●	20	26	18	1.35	1.45	12.0
				3W	1.6	●	●	●	○	18	22	14	1.60	1.15	17.0
				4W	2.0	●	●	○	○	16	18	12	2.00	1.75	24.0
7			307	0W	0.5	●	○ ³⁾	●	●	28	32	28	0.80	0.70	2.5
				1W	0.7	●	●	●	●	22	32	22	0.95	1.05	7.0 ²⁾
				2W	1.3	●	●	●	●	20	26	18	1.75	1.60	11.0
				3W	1.6	●	●	●	○	18	22	14	1.70	1.25	15.0
				4W	2.0	●	●	○	○	16	18	12	2.00	1.80	20.0
8			308	1W	0.7	●	●	●	●	22	32	22	0.95	1.15	5.0
				2W	0.9	●	●	●	●	22	32	20	1.50	1.25	10.0 ²⁾
8			308	3W	1.3	●	●	●	●	20	26	18	1.65	1.15	13.0
9			309	0W	0.5	●	○ ³⁾	●	●	28	32	28	0.60	0.50	2.0
9			309	3W	8x1.3 1x2.0	●	●	●		20 16	26 18	28 12	1.35	1.05	6.0 15.0

- First choice alternative
- Special order alternative

Note: ¹⁾ see calculation method, caution and suggested standard.
²⁾ rated current = 6A for socket with elbow (90°) contact for printed circuit.
³⁾ available only for connectors fitted with male contacts.

Multipole

	Solder contacts		Reference	Series	Contact ø (mm)	Contact type				AWG			Solder contact		Rated current (A) ¹⁾
	Crimp contacts					Solder	Crimp	Print (straight)	Print (elbow)	Solder (max.)	Crimp		Test voltage (kV rms) ¹⁾ Contact-contact	Test voltage (kV rms) ¹⁾ Contact-shell	
	min.	max.													
10			310	1W	0.5	●	○ ³⁾	●	●	28	32	28	0.90	1.50	2.5
				2W	0.9	●	●	●	●	22	32	20	1.45	1.30	8.0 ²⁾
				3W	1.3	●	●	●	●	20	26	18	1.25	0.90	12.0
				4W	1.6	●	●	○	○	18	22	14	1.85	1.30	17.0
				5W	3.0	●	●	○	○	12	14	10	2.35	2.30	20.0
12			312	2W	0.7	●	●	●	●	22	32	22	1.25	1.35	7.0 ²⁾
				3W	0.9	●	●	●	●	22	32	20	1.45	1.00	9.0
				4W	1.3	●	●	○	○	20	26	18	1.45	1.60	12.0
14			314	1W	0.5	●	○ ³⁾	●	●	28	32	28	0.80	1.20	2.0
				2W	0.7	●	●	●	●	22	32	22	1.15	1.35	6.5 ²⁾
				3W	0.9	●	●	●	●	22	32	20	1.20	1.20	9.0 ²⁾
				5W	2.0	●	●	○	○	16	18	12	2.10	2.00	18.0
16			316	1W	0.5	●	○ ³⁾	●	○	28	32	28	0.80	1.25	1.5
16			316	2W	0.7	●	●	●	●	22	32	22	0.95	1.25	6.0
				3W	0.9	●	●	●	●	22	32	20	1.20	0.85	8.0
				4W	0.9	●	●	●	○	22	32	20	1.35	1.50	10.0
				5W	2.0	●	●	○	○	16	18	12	1.85	1.95	12.0
18			318												
				2W	0.7	●	●	●	●	22	32	22	0.85	1.20	5.5
				3W	0.9	●	●	●	●	22	32	20	1.20	1.05	7.0

- First choice alternative
- Special order alternative

Note: ¹⁾ see calculation method, caution and suggested standard.
²⁾ rated current = 6A for socket with elbow (90°) contact for printed circuit.
³⁾ available only for connectors fitted with male contacts.



Multipole

	Solder contacts		Reference	Series	Contact ϕ (mm)	Contact type				AWG		Solder contact		Rated current (A) ¹⁾	
	Crimp contacts					Solder	Crimp	Print (straight)	Print (elbow)	Solder (max.)	Crimp		Test voltage (kV rms) ¹⁾ Contact-contact		Test voltage (kV rms) ¹⁾ Contact-shell
											min.	max.			
19			319	2W	0.7	●	●	●	●	22	32	22	0.95	1.25	5.0
20			320	3W	0.7	●	●	●	●	22	32	22	1.00	0.90	6.0
20			320	4W	0.9	●	●	●		22	32	20	1.35	1.00	8.0
					5W	1.6	●	●	○		18	22	14	1.90	1.70
22			322	3W	0.7	●	●	●	○	22	32	22	1.00	0.90	5.5
24			324	3W	0.7	●	●	●	●	22	32	22	0.95	0.80	4.0
					4W	0.9	●	●	●		22	32	20	1.20	1.45
26			326	2W	0.5	●		●	○	28			0.95	1.30	2.0
					3W	0.7	●	●	●	○	22	32	22	0.95	0.70

- First choice alternative
- Special order alternative

Note: ¹⁾ see calculation method, caution and suggested standard.

Multipole

	Solder contacts		Reference	Series	Contact ø (mm)	Contact type				AWG			Solder contact		Rated current (A) ¹⁾
	Crimp contacts					Solder	Crimp	Print (straight)	Print (elbow)	Solder (max.)	Crimp		Test voltage (kV rms) ¹⁾ Contact-contact	Test voltage (kV rms) ¹⁾ Contact-shell	
	min.	max.													
30			330	3W	0.7	●	●	●	●	22	32	22	0.80	0.70	3.5
				4W	0.9	●	●	●		22	32	20	0.95	0.85	5.0
				5W	1.3	●	●	○		20	26	18	1.45	1.60	8.0
32			332	2W	0.5	●		●	○	28			0.80	1.20	1.5
				3W	0.7	●	○	●	○	22	32	22	0.75	0.70	3.0
40			340	4W	0.7	●	●	●		22	32	22	0.90	0.90	2.0
				5W	1.3	●	●	○		20	26	18	1.30	1.45	7.0
48			348	4W	0.7	●	●	●		22	32	22	0.70	0.70	1.5
				5W	1.3	●	●	●		20	26	18	1.20	1.10	6.0
50			350	5W	0.9	●	●	●		22	32	20	1.30	1.60	6.0

● First choice alternative
○ Special order alternative

Note: ¹⁾ see calculation method, caution and suggested standard.



Multipole

	Solder contacts		Reference	Series	Contact ϕ (mm)	Contact type				AWG		Solder contact		Rated current (A) ¹⁾	
	Crimp contacts					Solder	Crimp	Print (straight)	Print (elbow)	Solder (max.)	Crimp		Test voltage (kV rms) ¹⁾ Contact-contact		Test voltage (kV rms) ¹⁾ Contact-shell
											min.	max.			
54			354	5W	0.9	●	●	●		22	32	20	1.15	1.55	5.0
64			364	5W	0.9	●	●	●		22	32	20	1.30	1.55	3.0

- First choice alternative
- Special order alternative

Note: ¹⁾ see calculation method, caution and suggested standard.

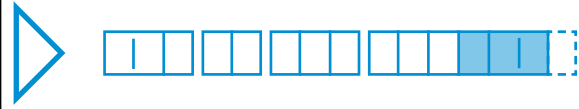

Collets

C and K type collets

0W, 1W, 2W and 3W series



	Reference		Collet ø		Cable ø	
	Type	Code	ø A	ø B	max.	min.
0W	C	10 ¹⁾	1.6	–	1.2	1.0
	C	15 ¹⁾	1.6	–	1.5	1.3
	C	20 ¹⁾	2.1	–	2.0	1.6
	C	25	3.1	–	2.5	2.1
	C	30	3.1	–	3.0	2.6
	C	35	4.2	4.2	3.5	3.1
	C	40	4.2	4.2	4.0	3.6
	C	45	5.2	5.2	4.5	4.1
	K	50	5.2	5.2	5.0	4.6
	K	55	6.2	6.2	5.5	5.1
	K	60	6.2	6.2	6.0	5.6
1W	C	30	3.2	–	3.0	2.6
	C	35	4.2	–	3.5	3.1
	C	40	4.2	–	4.0	3.6
	C	45	5.2	–	4.5	4.1
	C	50	5.2	–	5.0	4.6
	C	55	6.2	6.2	5.5	5.1
	C	60	6.2	6.2	6.0	5.6
	C	65	7.2	6.7	6.5	6.1
	K	70	7.2	–	7.0	6.6
	K	75	8.2	8.2	7.5	7.1
	K	80	8.2	8.2	8.0	7.6
2W	C	30	3.2	–	3.0	2.6
	C	35	4.2	–	3.5	3.1
	C	40	4.2	–	4.0	3.6
	C	45	5.2	–	4.5	4.1
	C	50	5.2	–	5.0	4.6
	C	55	6.2	6.2	5.5	5.1
	C	60	6.2	6.2	6.0	5.6
	C	65	7.2	6.7	6.5	6.1
	C	70	7.2	–	7.0	6.6
	C	75	8.2	8.2	7.5	7.1
	C	80	8.2	8.2	8.0	7.6

	Reference		Collet ø		Cable ø	
	Type	Code	ø A	ø B	max.	min.
2W	C	80	8.2	8.2	8.0	7.6
	C	85	9.2	8.6	8.5	8.1
	K	90	9.2	–	9.0	8.6
	K	95	10.2	10.2	9.5	9.1
	K	10	10.2	10.2	10.0	9.6
	K	11	11.2	10.6	10.5	10.1
3W	C	30	3.2	–	3.0	2.6
	C	35	4.2	–	3.5	3.1
	C	40	4.2	–	4.0	3.6
	C	45	5.2	–	4.5	4.1
	C	50	5.2	–	5.0	4.6
	C	55	6.2	–	5.5	5.1
	C	60	6.2	–	6.0	5.6
	C	65	7.2	–	6.5	6.1
	C	70	7.2	–	7.0	6.6
	C	75	8.2	–	7.5	7.1
	C	80	8.2	–	8.0	7.6
	C	85	9.2	–	8.5	8.1
	C	90	9.2	–	9.0	8.6
	C	95	10.2	10.2	9.5	9.1
	C	10	10.2	10.2	10.0	9.6
C	11	11.2	10.6	10.5	10.1	
K	11	12.3	–	12.0	10.6	
K	12	13.8	13.8	12.8	12.1	
K	13	13.8	13.8	13.5	12.9	
K	14	15.3	15.3	14.0	13.6	
K	15	15.3	15.3	15.0	14.1	

Note: All dimensions are in millimetres.

¹⁾ the inner diameter of the smallest bend relief available is 2.5 mm (in TPU) / 1.7 mm (in silicone).



C and K type collets

4W series



4W

Reference		Collet ø		Cable ø	
Type	Code	ø A	ø B	max.	min.
C	50	6.3	–	5.0	4.8
C	55	6.3	–	5.5	5.1
C	60	6.3	–	6.0	5.6
C	65	7.3	–	6.5	6.1
C	70	7.3	–	7.0	6.6
C	75	8.3	–	7.5	7.1
C	80	8.3	–	8.0	7.6
C	85	9.3	–	8.5	8.1
C	90	9.3	–	9.0	8.6
C	95	10.8	–	9.5	9.1
C	10	10.8	–	10.5	9.6
C	11	12.3	–	12.0	10.6
C	12	13.8	13.8	12.8	12.1
C	13	13.8	13.8	13.5	12.9
C	14	15.3	15.3	14.0	13.6
C	15	15.3	15.3	15.0	14.1
K	16	17.8	–	16.5	15.6
K	17	17.8	–	17.5	16.6
K	18	19.8	–	18.5	17.6
K	19	19.8	–	19.5	18.6
K	20	21.8	–	20.5	19.6
K	21	21.8	–	21.5	20.6
K	22	23.8	23.8	22.5	21.6
K	23	23.8	23.8	23.5	22.6

5W series



5W

Reference		Collet ø		Cable ø	
Type	Code	ø A	ø B	max.	min.
C	10	11.8	–	10.5	9.6
C	11	11.8	–	11.5	10.6
C	12	13.8	–	12.5	11.6
C	13	13.8	–	13.5	12.6
C	14	15.8	–	14.5	13.6
C	15	15.8	–	15.5	14.6
C	16	17.8	–	16.5	15.6
C	17	17.8	–	17.5	16.6
C	18	19.8	–	18.5	17.6
C	19	19.8	–	19.5	18.6
C	20	21.8	–	20.5	19.6
C	21	21.8	–	21.5	20.6
C	22	23.8	23.8	22.5	21.6
C	23	23.8	23.8	23.5	22.6

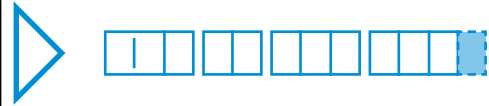

Variant

Bend relief for W series models with collet

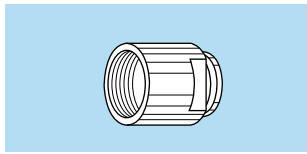

Need to be ordered

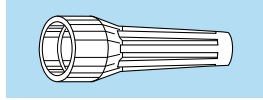

Need to be ordered separately

	Ref.	Collet		Need to be ordered separately
		Type	Code	
0W	z	C	30 to 45	GMA.0B.●●●●●●
		K	50	GMA.1B.●●●●●●
1W	z	C	30 to 65	GMA.1B.●●●●●●
		K	70 to 85	GMA.2B.●●●●●●
2W	z	C	30 to 85	GMA.2B.●●●●●●
		K	90 to 10	GMA.3B.●●●●●●

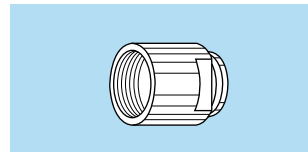

Need to be ordered

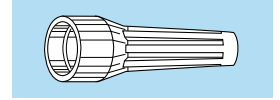

Need to be ordered separately

	Ref.	Collet		Need to be ordered separately
		Type	Code	
3W	z	C	30 to 10	GMA.3B.●●●●●●
		K	11 to 15	GMA.4B.●●●●●●
4W	z	C	50 to 15	GMA.4B.●●●●●●

Note: The bend relief must be ordered separately (see pages 141 and 142 of the unipole/multipole catalog). All dimensions are in millimetres.

Accessories

BFG Plug caps with key (G) (IP68 and resistance to hydrostatic pressure 30 bars)

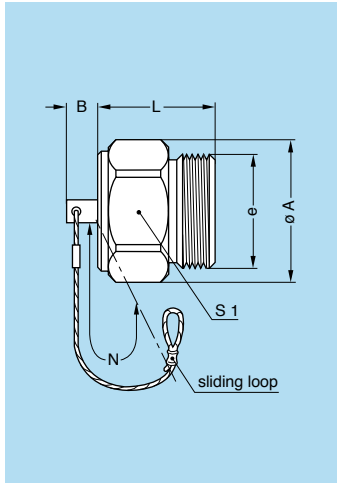

Part number	Series	Dimensions (mm)					
		A	B	e	L	N ¹⁾	S1
BFG.0W.100.●AZ	0W	17.2	6	M14x1.0	12.5	85	16
BFG.1W.100.●AZ	1W	19.3	6	M16x1.0	15.5	85	18
BFG.2W.100.●AZ	2W	23.5	6	M20x1.0	17.5	85	22
BFG.3W.100.●AZ	3W	27.8	6	M24x1.0	22.0	120	26
BFG.4W.100.●AZ	4W	34.3	10	M30x1.0	22.5	120	32
BFG.5W.100.●AZ	5W	50.0	10	M45x1.5	27.0	120	47

Note: ¹⁾ the tolerance on this dimension is ± 5 mm.

- Body material: ● = N, nickel-plated brass (Ni 3µm)
● = S, stainless steel
- Lanyard material: Stainless steel
- Crimp ferrule material: Nickel-plated brass

BRE Blanking caps for fixed sockets (This cap is only IP68 when installed)

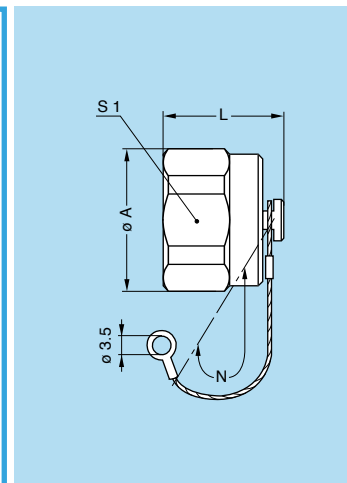

Part number	Series	Dimensions (mm)			
		A	L	N ¹⁾	S1
BRE.0V.200.●AV	0W	17.2	13.7	85	16
BRE.1V.200.●AV	1W	19.3	13.7	85	18
BRE.2V.200.●AV	2W	23.5	14.7	85	22
BRE.3V.200.●AV	3W	27.8	14.7	120	26
BRE.4V.200.●AV	4W	34.3	14.7	120	32
BRE.5V.200.●AV	5W	50.0	16.2	120	47

Note: 1) the tolerance on this dimension is ± 5 mm.

- Body material: ● = N, nickel-plated brass (Ni 3 μ m)
● = S, stainless steel
- Lanyard material: Stainless steel
- Crimp ferrule material: Nickel-plated brass
- O-ring: FPM (Viton®)

BRF Blanking caps for free sockets (This cap is only IP68 when installed)

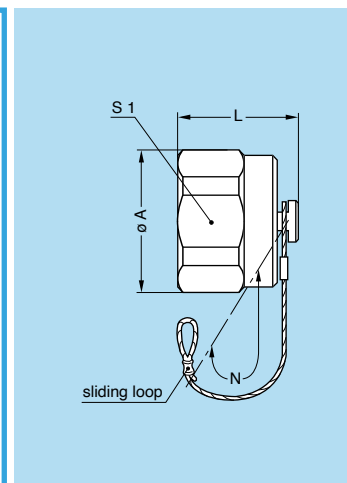

Part number	Series	Dimensions (mm)			
		A	L	N ¹⁾	S1
BRF.0V.200.●AV	0W	17.2	13.7	85	16
BRF.1V.200.●AV	1W	19.3	13.7	85	18
BRF.2V.200.●AV	2W	23.5	14.7	85	22
BRF.3V.200.●AV	3W	27.8	14.7	120	26
BRF.4V.200.●AV	4W	34.3	14.7	120	32
BRF.5V.200.●AV	5W	50.0	16.2	120	47

Note: 1) the tolerance on this dimension is ± 5 mm.

- Body material: ● = N, nickel-plated brass (Ni 3 μ m)
● = S, stainless steel
- Lanyard material: Stainless steel
- Crimp ferrule material: Nickel-plated brass
- O-ring: FPM (Viton®)

GEA Hexagonal nuts

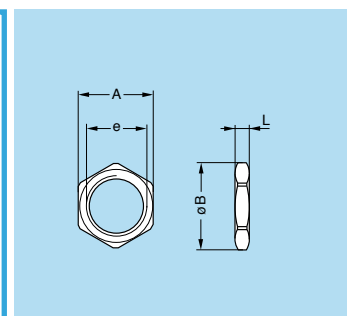

Part number	Series	Dimensions (mm)			
		A	B	e	L
GEA.1S.240.LN	0W	14	15.8	M12 x 1.00	2.5
GEA.0E.240.LN	1W	17	19.2	M14 x 1.00	2.5
GEA.1E.240.LN	2W	19	21.5	M16 x 1.00	3.0
GEA.2E.240.LN	3W	24	27.0	M20 x 1.00	4.0
GEA.3E.240.LN	4W	30	34.0	M24 x 1.00	5.0
GEA.5W.240.LN	5W	46	53.0	M38 x 1.50	8.0

- Material:
 - Nickel-plated brass (3 μ m)
 - Stainless steel

Note: to order this part separately, use the above part numbers. The last letters «LN» of the part number refer to the nut material and treatment. If a nut in stainless steel is desired, replace the last letters of the part number by «AZ».

GDA O-ring for plug

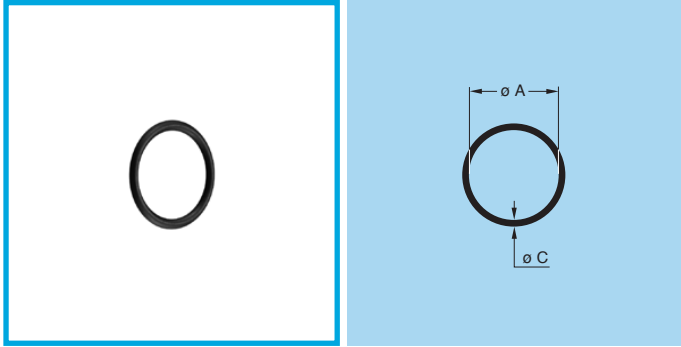

Part number	Series	Dim. (mm)	
		A	C
GDA.99.070.100VK	0W	7.0	1.00
GDA.99.090.125VK	1W	9.0	1.25
GDA.99.120.150VK	2W	12.0	1.50
GDA.99.150.150VK	3W	15.0	1.50
GDA.99.190.200VK	4W	19.0	2.00
GDA.99.310.250VK	5W	31.0	2.50

● Material: FPM (Viton®)

Panel cut-outs

Panel Cut-outs

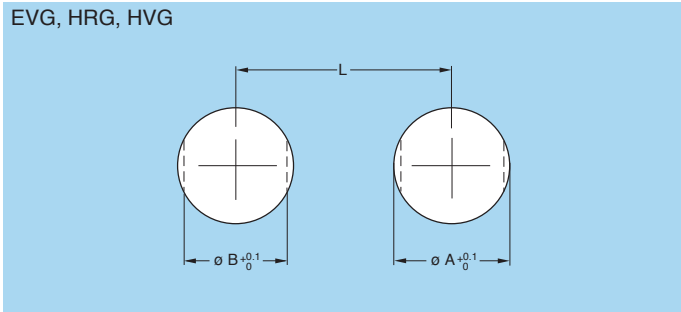

Series	Dimensions (mm)		
	A	B	L
0W	12.1	10.6	19.0
1W	14.1	12.6	21.0
2W	16.1	14.6	25.5
3W	20.2	18.6	30.0
4W	24.2	22.6	37.0
5W	38.2	35.6	53.0

Mounting nuts torque

Component	Torque (Nm)					
	0W	1W	2W	3W	4W	5W
Collet nut for F●● and P●●	0.7	0.8	2	3	5	8
Mounting hex nut for sockets	5	7	9	12	17	22
Coupling nut	0.7	0.8	2	3	5	8

1N = 0.102 kg

Cable assembly

Assembly instructions

In order to ensure the sealing of plugs and sockets on the cable side, it is imperatively necessary to complete their assembly by realizing it with an adapted technique. We recommend the fitting of an heatshrink boot with inner melting coating of type ATUM (manufactured by the RAYCHEM company) or similar.

This heatshrink boot is not provided with the connector. Please consult us.

Product safety notice

PLEASE READ AND FOLLOW ALL INSTRUCTIONS CAREFULLY AND CONSULT ALL RELEVANT NATIONAL AND INTERNATIONAL SAFETY REGULATIONS FOR YOUR APPLICATION. IMPROPER HANDLING, CABLE ASSEMBLY, OR WRONG USE OF CONNECTORS CAN RESULT IN HAZARDOUS SITUATIONS.

1. SHOCK AND FIRE HAZARD

Incorrect wiring, the use of damaged components, presence of foreign objects (such as metal debris), and / or residue (such as cleaning fluids), can result in short circuits, overheating, and / or risk of electric shock.

Mated components should never be disconnected while live as this may result in an exposed electric arc and local overheating, resulting in possible damage to components.

2. HANDLING

Connectors and their components should be visually inspected for damage prior to installation and assembly. Suspect components should be rejected or returned to the factory for verification.

Connector assembly and installation should only be carried out by properly trained personnel. Proper tools must be used during installation and / or assembly in order to obtain safe and reliable performance.

3. USE

Connectors with exposed contacts should never be live (or on the current supply side of a circuit). Under general conditions voltages above 30 VAC and 42 VDC are considered hazardous and proper measures should be taken to eliminate all risk of transmission of such voltages to any exposed metal part of the connector.

4. TEST AND OPERATING VOLTAGES

The maximum admissible operating voltage depends upon the national or international standards in force for the application in question. Air and creepage distances impact the operating voltage; reference values are indicated in the catalog however these may be influenced by PC board design and / or wiring harnesses.

The test voltage indicated in the catalog is 75% of the mean breakdown voltage; the test is applied at 500 V/s and the test duration is 1 minute.

5. CE MARKING

CE marking  means that the appliance or equipment bearing it complies with the protection requirements of one or several European safety directives.

CE marking  applies to complete products or equipment, **but not to electromechanical components, such as connectors.**

6. PRODUCT IMPROVEMENTS

The LEMO Group reserves the right to modify and improve to our products or specifications without providing prior notification.

7. WARNING (Prop 65 State of California)

Proposition 65 requires businesses to provide warnings to Californians about significant exposures to chemicals that cause cancer, birth defects or other reproductive harm. LEMO products are exempt from proposition 65 warnings because they are manufactured, marketed, and sold solely for commercial and industrial use. For further information, please visit <https://www.lemo.com/quality/LEMO-Prop-65-compliance-declaration.pdf>.

Disclaimers

LEMO works constantly to improve the quality of its products; the information and illustrations figuring in this document may therefore vary and are not binding. In any case, LEMO makes no specific warranty of merchantability, fitness for a particular purpose, third party components as such or included in assembly, non-infringement, title, accuracy, completeness, or security. The user is fully responsible for his products and applications using LEMO component.

In no event shall LEMO, its affiliates, officers, agents or employees be liable for any incidental, indirect, special or consequential damages in connection with the products or services provided by LEMO, including (without limitation) loss of profits or revenues, interruption of business, loss of use of the products or any associated equipment, materials, components or products, damages to associated equipment or in combination with other components, materials.

Reproduction of significant portions of LEMO information in LEMO data books or data sheets is permissible only if reproduction is without alteration and is accompanied by all associated warranties, conditions, limitations, and notices. LEMO is not responsible or liable for such altered documentation. Information of third parties may be subject to additional restrictions.

LEMO complete product range

	B	S	K	T	E	F	00	01	0A	3T	4A	4M	3K.93C	1D	Y	05	5G	2G.2C	L	H	M	R	N	03	V	W	T7	P	SP	D	K/S	01	DIN		
Unipole																																			
Multipole																																			
Coaxial 50 Ω																																			
Coaxial 75 Ω																																			
Multi Coaxial																																			
Mixed Coax + LV																																			
Triaxial 50 Ω																																			
Triaxial 75 Ω																																			
Mixed Triax + LV																																			
Quadrax																																			
High Voltage																																			
Multi High Voltage																																			
Mixed HV + LV																																			
Fibre Optic																																			
Multi Fibre Optic																																			
Mixed FO + LV																																			
Thermocouple																																			
Fluidic																																			
Multi Fluidic																																			
Mixed Fluidic + LV																																			

Most frequently used in darker colour

● included in this catalogue

B Series <small>Keyed</small>	S Series	K Series <small>Keyed</small>	T Series	E Series	F Series <small>Keyed</small>	00 Series
01 Series	0A Series	3T Series	4A Series	4M Series <small>Keyed</small>	3K.93C Series <small>Keyed</small>	1D Series
Y Series	05 Series	5G Series <small>Keyed</small>	2G Series <small>Keyed</small>	2C Series	L Series <small>Keyed</small>	H Series
M Series <small>Keyed</small>	R Series <small>Keyed</small>	N Series <small>Keyed</small>	03 Series <small>Keyed</small>	V Series	W Series <small>Keyed</small>	Cable assembly
REDEL T7 Series	REDEL P Series <small>Keyed</small>	REDEL SP Series <small>Keyed</small>	REDEL D Series	01 Series <small>Keyed</small>	VAA Series	TAA Series

LEMO HEADQUARTERS

SWITZERLAND

LEMO SA
Chemin des Champs-Courbes 28 - P.O. Box 194 - CH-1024 Ecublens
Tel. +41 21 695 16 00 - e-mail: info@lemo.com

LEMO SUBSIDIARIES

AUSTRIA

LEMO Elektronik GesmbH
Lemböckgasse 49/E6-3
1230 Wien
Tel: +43 1 914 23 20 0
Fax: +43 1 914 23 20 11
salesAT@lemo.com

BRAZIL

LEMO Latin America Ltda
Av. Dr. Adhemar de Barros,
566 – Sala 1407, Vila Adyana
CEP: 12245-011
São José dos Campos - SP - Brazil
Tel: +55 11 94242 4293
info-la@lemo.com

CANADA

LEMO Canada Inc
44 East Beaver Creek Road, unit 20
Richmond Hill, Ontario L4B 1G8
Tel: +1 905 889 56 78
Fax: +1 905 889 49 70
info-canada@lemo.com

CHINA / HONG KONG

LEMO Electronics (Shanghai) Co., Ltd
First Floor, Block E,
18 Jindian Road, Pudong
Shanghai, China, 201206
Tel: +86 21 5899 7721
Fax: +86 21 5899 7727
cn.sales@lemo.com

DENMARK

LEMO Denmark A/S
Mandal Allé 16A
5500 Middelfart
Tel: +45 45 20 44 00
Fax: +45 45 20 44 01
info-dk@lemo.com

FRANCE

LEMO France Sàrl
24/28 Avenue Graham Bell
Bâtiment Balthus 4
Bussy Saint Georges
77607 Marne la Vallée Cedex 3
Tel: +33 1 60 94 60 94
Fax: +33 1 60 94 60 90
info-fr@lemo.com

GERMANY

LEMO Elektronik GmbH
Hanns-Schwindt-Str. 6
81829 München
Tel: +49 89 42 77 03
Fax: +49 89 420 21 92
info@lemo.de

HUNGARY

REDEL Elektronika Kft
Nagysándor József u. 6-12
1201 Budapest
Tel: +36 1 421 47 10
Fax: +36 1 421 47 57
info-hu@lemo.com

ITALY

LEMO Italia srl
Viale Lunigiana 25
20125 Milano
Tel: +39 02 66 71 10 46
Fax: +39 02 37 90 80 46
sales.it@lemo.com

JAPAN

LEMO Japan Ltd
2-7-22, Mita,
Minato-ku, Tokyo, 108-0073
Tel: +81 3 54 46 55 10
Fax: +81 3 54 46 55 11
info-jp@lemo.com

NETHERLANDS / BELGIUM

LEMO Connectors Nederland B.V.
Jacques Meuwissenweg 6
2031 AD Haarlem
Tel. +31 23 206 07 01
info-nl@lemo.com

NORWAY / ICELAND

LEMO Norway A/S
Soerumsandvegen 69,
1920 Soerumsand
Tel: +47 22 91 70 40
Fax: +47 22 91 70 41
info-no@lemo.com

SINGAPORE

LEMO Asia Pte Ltd
4 Leng Kee Road,
#06-09 SiS Building
Singapore 159088
Tel: +65 6476 0672
Fax: +65 6474 0672
sg.sales@lemo.com

SPAIN / PORTUGAL

IBERLEMO SAU
Brasil, 45, 08402 Granollers
Barcelona
Tel: +34 93 860 44 20
Fax: +34 93 879 10 77
info-es@lemo.com

SWEDEN / FINLAND

LEMO Nordic AB
Gunnabogatan 30, Box 8201
163 08 Spånga
Tel: +46 8 635 60 60
Fax: +46 8 635 60 61
info-se@lemo.com

SWITZERLAND

LEMO Verkauf AG
Grundstrasse 22 B,
6343 Rotkreuz
Tel: +41 41 790 49 40
ch.sales@lemo.com

TAIWAN

TAOYUAN TAIWAN
Tel: +886 967 132 824
speng@lemo.com

UNITED ARAB EMIRATES

LEMO Middle East Connectors LLC
Concorde Tower 11th Floor,
Office 1102, Dubai Media City,
P.O. Box 449849
Dubai, United Arab Emirates
Tel: +971 4 568 1904
info-me@lemo.com

UNITED KINGDOM

LEMO UK Ltd
12-20 North Street, Worthing,
West Sussex, BN11 1DU
Tel: +44 1903 23 45 43
lemouk@lemo.com

USA

LEMO USA Inc
P.O. Box 2408
Rohnert Park, CA 94927-2408
Tel: +1 707 578 88 11
+1 800 444 53 66
Fax: +1 707 578 08 69
info-US@lemo.com

LEMO DISTRIBUTORS

ARGENTINA, AUSTRALIA, BRAZIL, CHILE, COLOMBIA, CZECH REPUBLIC,
GREECE, INDIA, ISRAEL, NEW ZEALAND, PERU, POLAND, RUSSIA,
SOUTH AFRICA, SOUTH KOREA, TURKEY, UKRAINE

www.lemo.com