

- Designed for SDARS IF Receiver
- Low Insertion Loss
- 5.0 X 7.0 mm Surface-Mount Case
- Differential Input and Output
- Complies with Directive 2002/95/EC (RoHS)
- Tape & Reel Standard per ANSI/EIA481
- Moisture Sensitivity Level: 1
- AEC-Q200 Qualified

RoHS
Compliant

SF1141B

75.00 MHz
SAW Filter

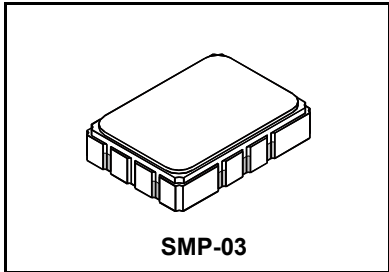

Absolute Maximum Ratings

Rating	Value	Units
Maximum Incident Power in Passband	+10	dBm
Max. DC voltage between any 2 terminals	30	VDC
Storage Temperature Range	-40 to +85	°C
Max Soldering Profile	265°C for 10 s	

Electrical Characteristics

Characteristic	Sym	Notes	Min	Typ	Max	Units
Nominal Center Frequency	f_c	1		75.000		MHz
Passband	IL	1, 2		12.5	16.0	dB
1dB Passband	BW_1		±6.35	±7.43		MHz
Fast Amplitude Ripple over $f_c \pm 6.35$ MHz					1.5	dB _{P-P}
Group Delay Variation over $f_c \pm 6.35$ MHz	GDV			75	200	ns _{P-P}
Rejection		1, 2, 3	40	45		dB
$f_c - 100$ to $f_c - 10.95$ and $f_c + 18.8$ to $f_c + 100$ MHz $f_c + 10.95$ to $f_c + 18.8$ MHz			30	36		
Operating Temperature Range	T_A	1	-40		+85	°C
Differential Input and Output Impedance			250 ohms			
Case Style		6	SMP-03 7 x 5 mm Nominal Footprint			
Lid Symbolization (YY=year, WW=week, S=shift) See note 4			RFM SF1141B YYWWSS			

Electrical Connections

Connection	Terminals
Port 1 Hot	10
Port 1 Ground Return	1
Port 2 Hot	5
Port 2 Ground Return	6
Case Ground	All Others



CAUTION: Electrostatic Sensitive Device. Observe precautions for handling.

NOTES:

1. The design, manufacturing process, and specifications of this device are subject to change.
2. US or International patents may apply.
3. RoHS compliant from the first date of manufacture.

NOTES:

- 1 USE A WRIST STRAP WHEN SOLDERING TRANS 1, AND TRANS 2 TO PCB.
(CUT LEADS .87 IN.)
- 2 MOUNT AND SOLDER ALL COMPONENTS ON PCB.
- 3 CUT CENTER CONDUCTORS FROM J1 AND J2 TO .18 IN.
- 4 MOUNT J1 AND J2 AS SHOWN (SOLDER BACKSIDE ALSO).
- 5 LABEL DEMO BOARD ACCORDINGLY.
- 6 MOUNT "FILTER" ON TOPSIDE OF PCB AS SHOWN.

REV	SIZE	DESCRIPTION	DATE
A	9248	INITIAL RELEASE	11dec88
B	18658	REVISED	30apr92
C	11676	REVISED	28nov92

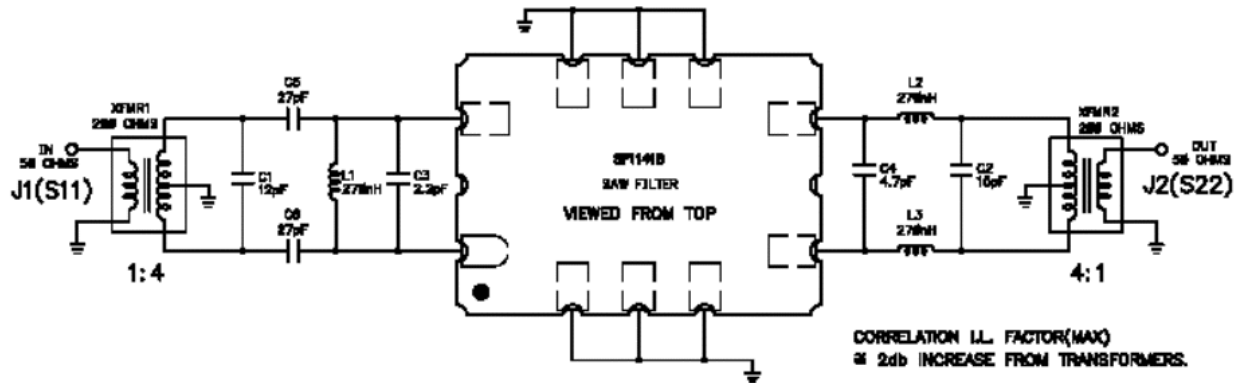

TITLE				
ASSY DIAGRAM, DEMO BOARD, SF1141B, S, TD				
SIZE	FORM NO.	QWL NO.	REV	SHEET
B	2U874	SF1141B-100	C	1/2

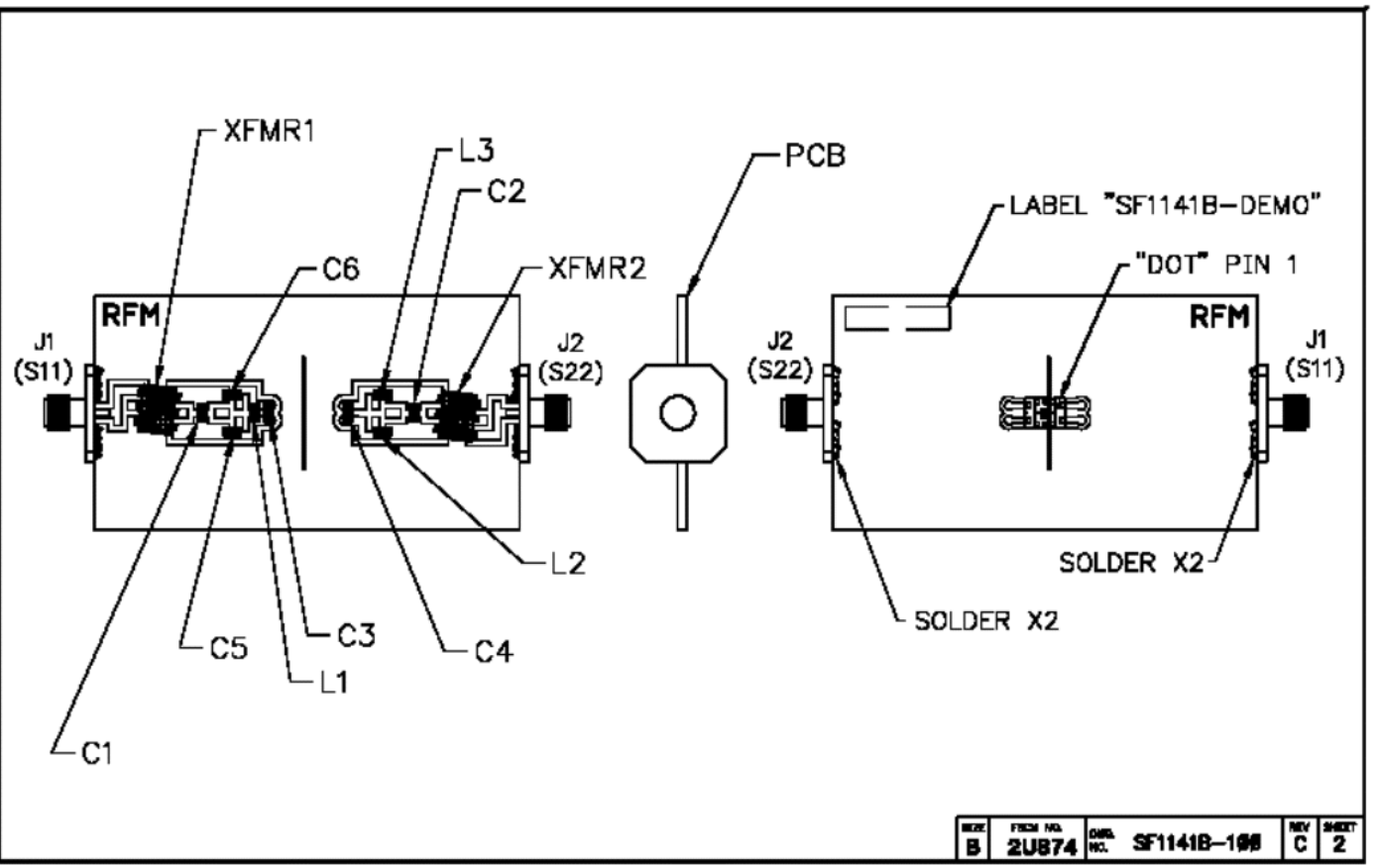

SIZE	FORM NO.	QWL NO.	REV	SHEET
B	2U874	SF1141B-100	C	2

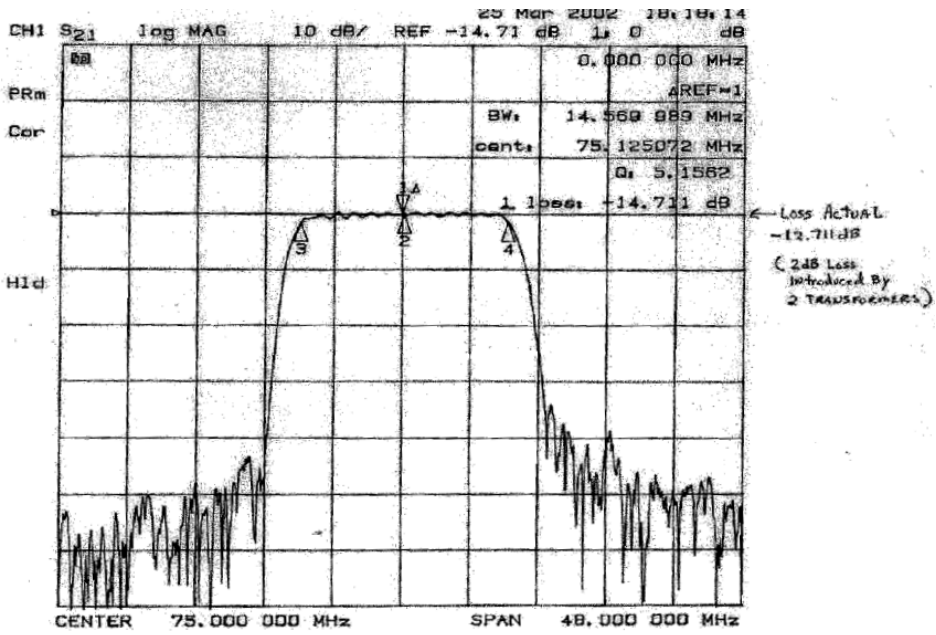

25 Mar 2002 18:20:56

CH1 S₁₁ 1 U FS 1 44.408 n 20.768 n 44.07 nH

PRm

Cor

75.000 000 MHz

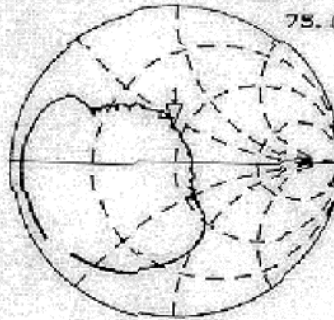

CH2 S₂₂ 1 U FS L 23.957 n 34.564 n 73.348 nH

PRm

Cor

75.000 000 MHz

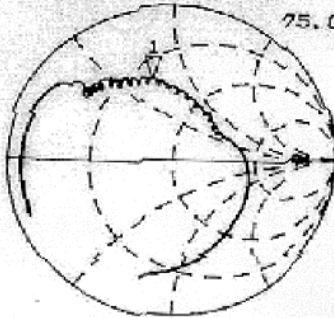

H1d

START 51.000 000 MHz STOP 99.000 000 MHz

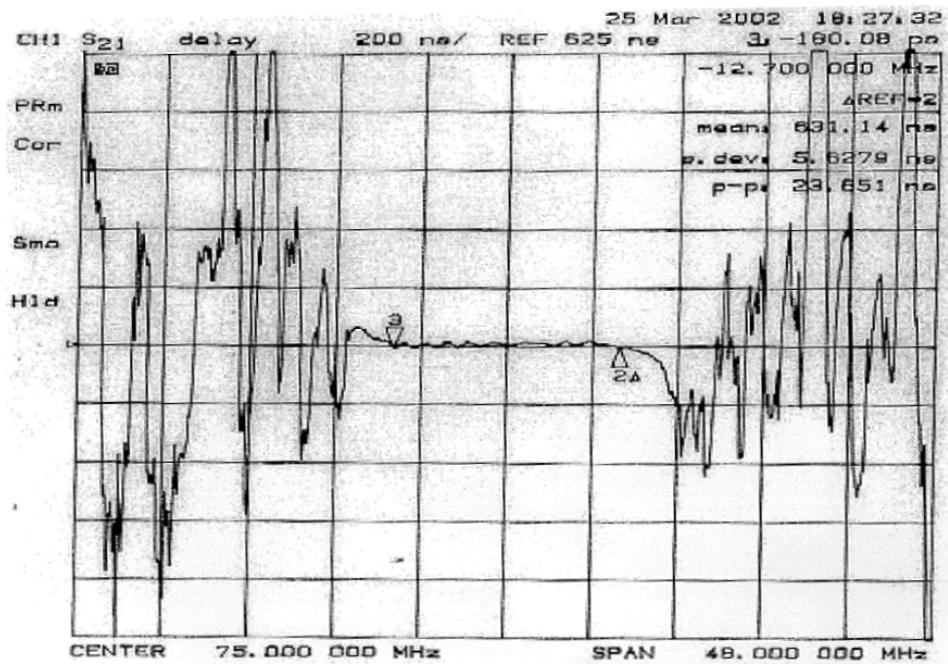

Tape and Reel Specifications

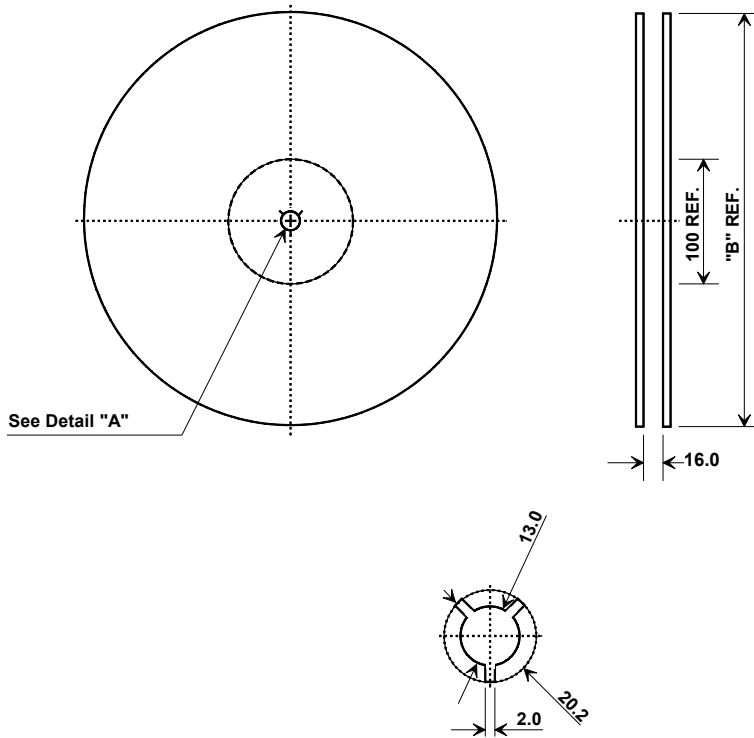

"B "		Quantity Per Reel
Nominal Size		
Inches	millimeters	
7	178	500
13	330	2000

COMPONENT ORIENTATION and DIMENSIONS

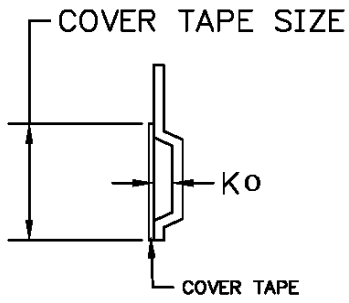

Carrier Tape Dimensions		Tolerance
Ao	5.5 mm	± 0.1mm
Bo	7.5 mm	± 0.1mm
Ko	2.0 mm	± 0.1mm
Pitch	8.0 mm	± 0.1mm
W	16.0 mm	± 0.2mm

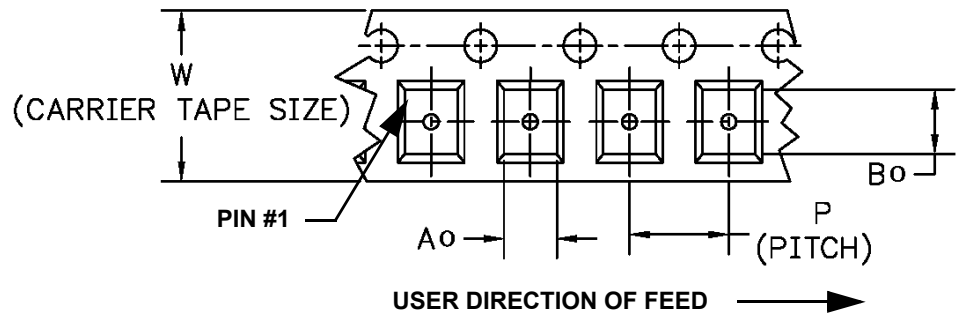

SMP-03 Case

10-Terminal Ceramic Surface-Mount Case 7 x 5 mm Nominal Footprint

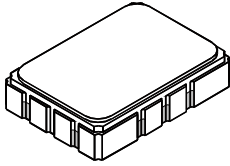

Recommended PCB Footprint

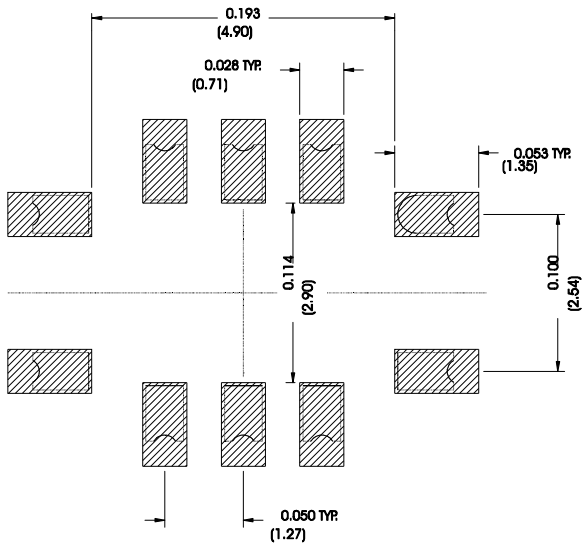

Case Dimensions						
Dimension	mm			Inches		
	Min	Nom	Max	Min	Nom	Max
A	6.80	7.00	7.20	0.268	0.276	0.283
B	4.80	5.00	5.20	0.189	0.197	0.205
C		1.65	2.00		0.065	0.079
D	.47	0.60	.73	0.019	0.024	0.029
E	2.41	2.54	2.67	0.095	0.100	0.105
H	0.87	1.0	1.13	0.034	0.039	0.044
J	4.87	5.00	5.13	0.192	0.197	0.202
K	2.87	3.00	3.13	0.113	0.118	0.123
P	1.14	1.27	1.40	0.045	0.050	0.055

Materials	
Solder Pad Termination	Au plating 30 - 60 ulnches (76.2-152 uM) over 80-200 ulnches (203-508 uM) Ni.
Lid	Fe-Ni-Co Alloy Electroless Nickel Plate (8-11% Phosphorus) 100-200 ulnches Thick
Body	Al ₂ O ₃ Ceramic

Electrical Connections		
Connection		Terminals
Port 1	Input or Return	10
	Return or Input	1
Port 2	Output or Return	5
	Return or Output	6
Ground		All others
Single Ended Operation		Return is ground
Differential Operation		Return is hot

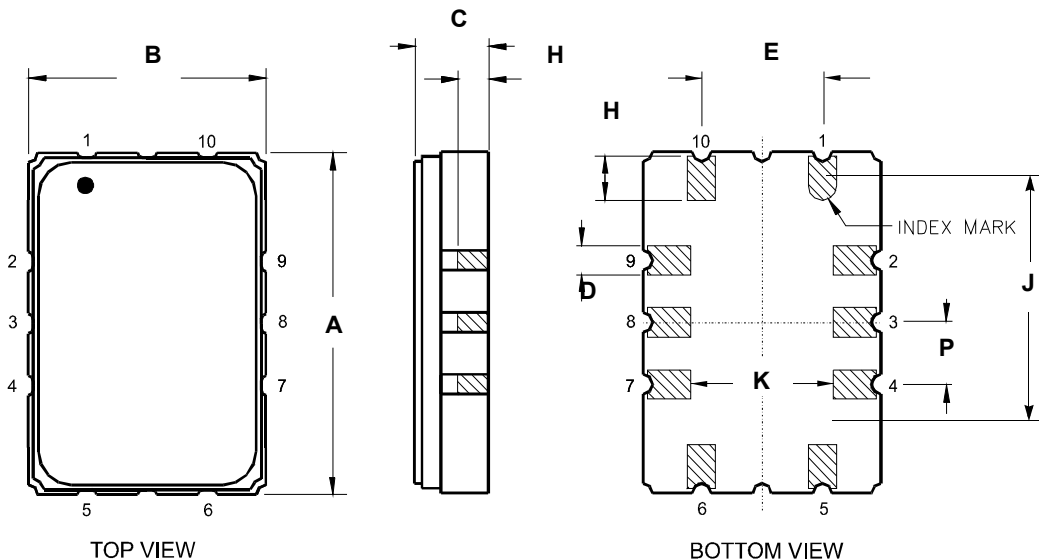

Recommended Reflow Profile

1. Preheating shall be fixed at 150~180° for 60~90 seconds.
2. Ascending time to preheating temperature 150° shall be 30 seconds min.
3. Heating shall be fixed at 220°C for 50~80 seconds and at 260°C peak (10 seconds.)
4. Time: 5 times maximum

