

- RF Filter for Mobile Communication Applications
- No Matching Circuit Required
- 3.0 x 3.0 x 1.3 mm Package
- Complies with Directive 2011/65/EU (RoHS)
- Moisture Sensitivity Level: 1

RoHS
Compliant

SF1192B

1842.5 MHz
SAW Filter

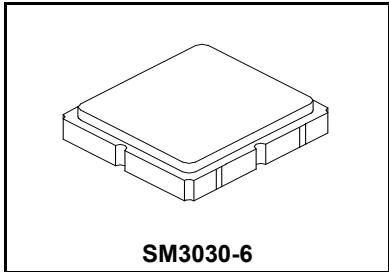

Absolute Maximum Ratings

Rating	Value	Units
Maximum Input Power	+10	dBm
DC voltage between Terminals	0	VDC
Operable Temperature Range	-45 to +125	°C
Storage Temperature	-40 to +85	°C
Suitable for lead-free soldering - Max Soldering Temperature	260°C for 30 s	

Electrical Characteristics

Characteristic	Sym	Notes	Min	Typ	Max	Units
Nominal Operating Frequency	f_c			1842.5		MHz
Passband	IL	Insertion Loss across $f_c \pm 37.5$ MHz		2.2	3.8	dB
		Amplitude Ripple p-p across $f_c \pm 37.5$ MHz		1.3	2.3	dB
Attenuation		1542.5 ~ 1600 MHz	20.0	24.5		dB
		1600 ~ 1710 MHz	22.0	25.0		dB
		1710 ~ 1785 MHz	10.0	23.5		dB
		1920 ~ 2142.5 MHz	25.0	28.0		dB
VSWR across $f_c \pm 37.5$ MHz				1.9	2.6	
Source impedance	Z_s			50		Ω
Load impedance	Z_L			50		Ω
Specification Temperature Range	T_A		-30		+85	°C

Case Style	SM3030-6 3 x 3 mm Nominal Footprint
Lid Symbolization (Y=year, WW=week, S=Shift)	454 YWWS
Standard Reel Quantity	500 Pieces Per Reel
Reel Size 7 Inch	
Reel Size 13 Inch	3000 Pieces Per Reel

Electrical Connections

Connection	Terminals
Input	2
Output	5
Ground	All others

CAUTION: Electrostatic Sensitive Device. Observe precautions for handling.

NOTES:

1. The design, manufacturing process, and specifications of this device are subject to change.
2. US or International patents may apply.
3. RoHS compliant from the first date of manufacture.

**Frequency Characteristics:
Transfer Function**

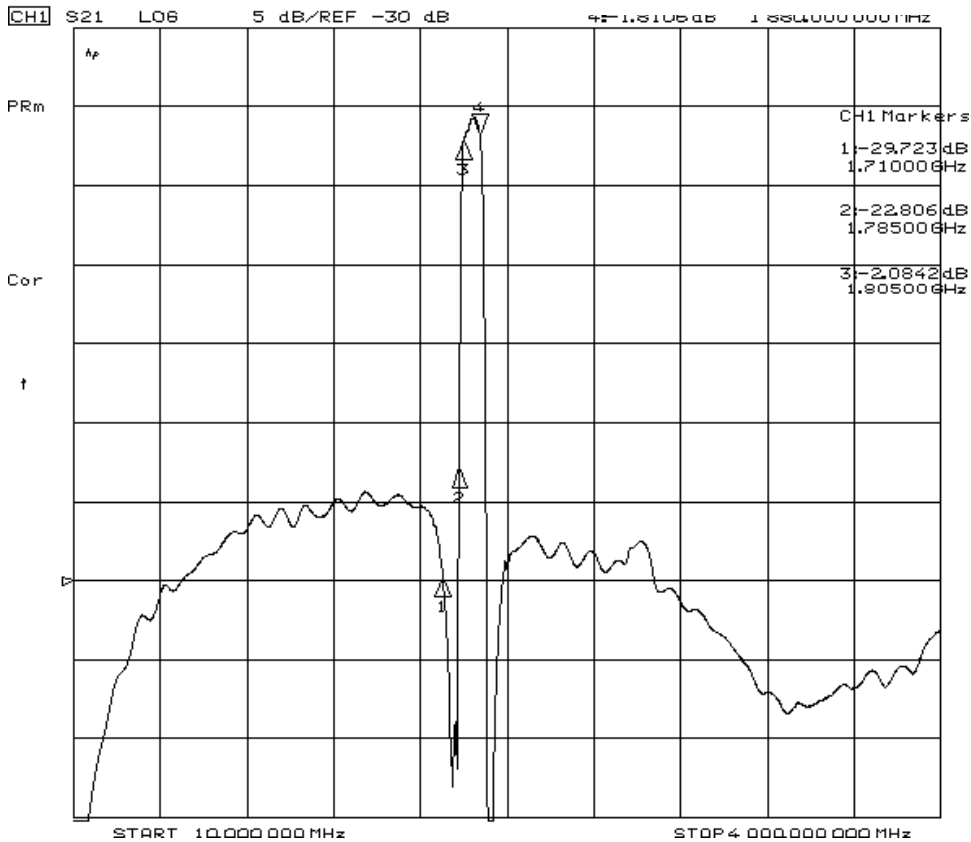
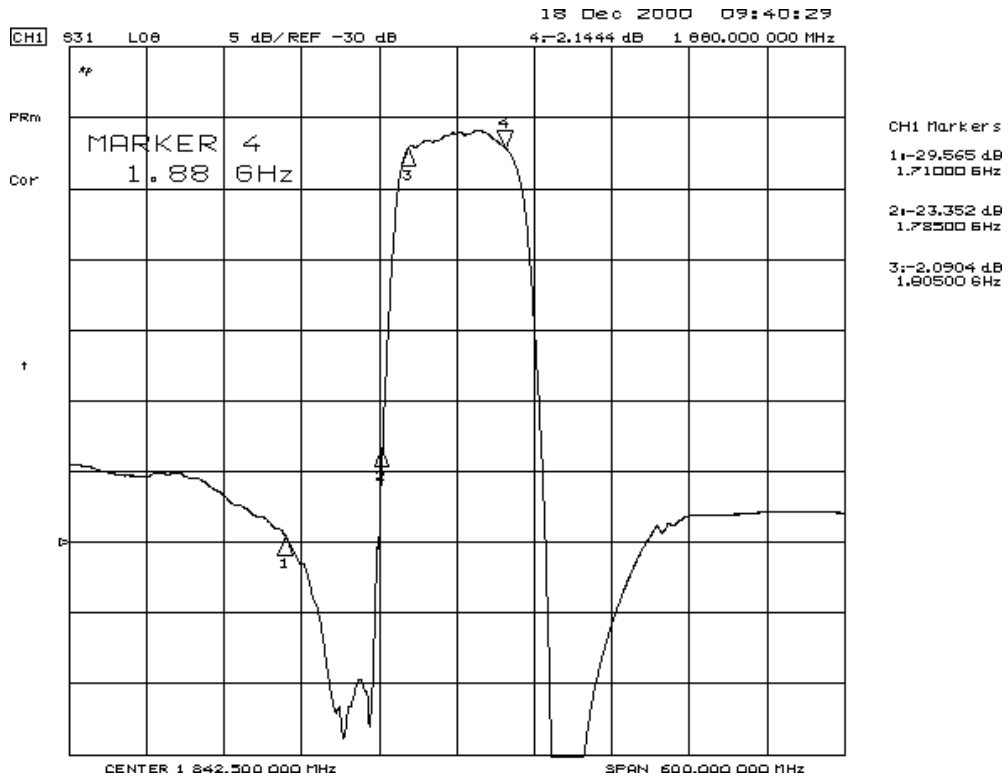

Reflections Functions:

S11 VSWR

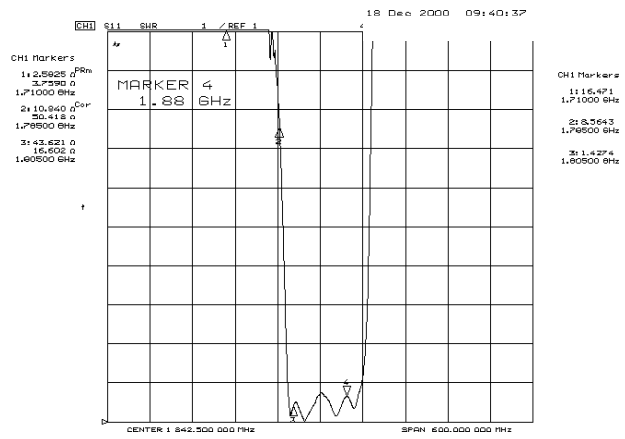
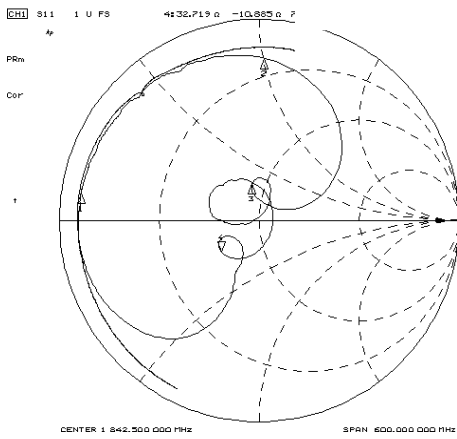

S22 VSWR

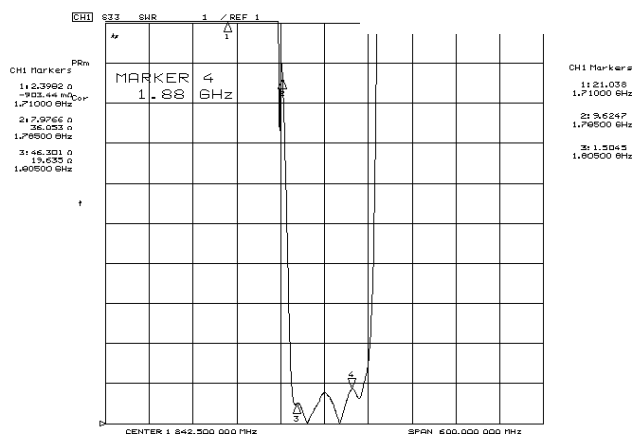
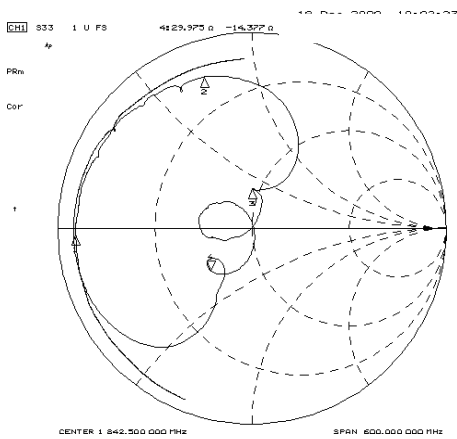

Tape and Reel Specifications

Tape and Reel Standard per ANSI/EIA-481

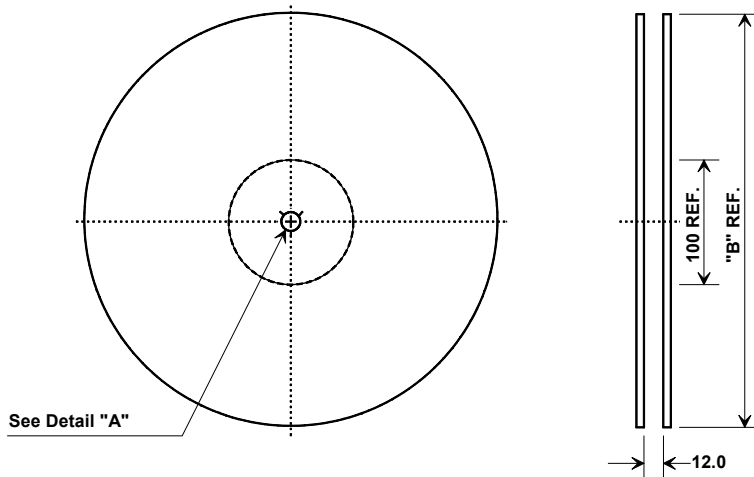

"B" Nominal Size		Quantity Per Reel
Inches	millimeters	
7	178	500
13	330	3000

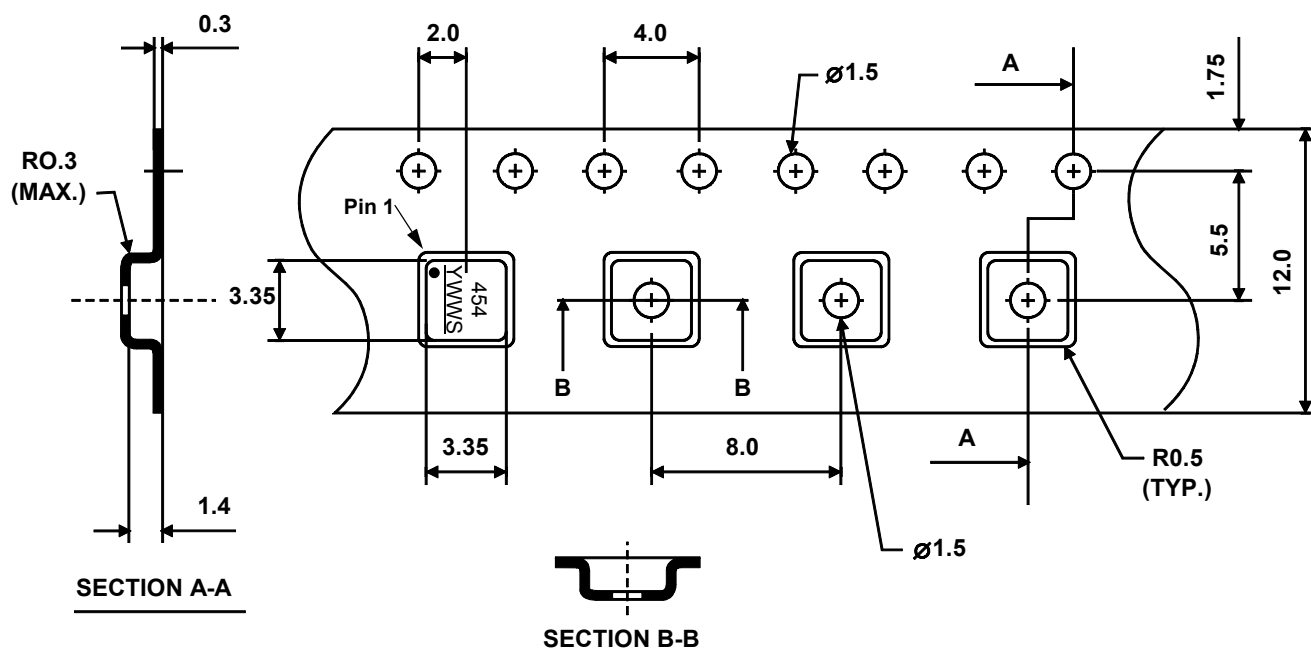
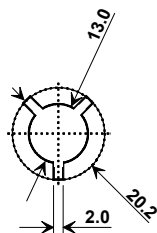

SM3030-6 Case

6-Terminal Ceramic Surface-Mount Case 3.0 X 3.0 mm Nominal Footprint

Case Dimensions

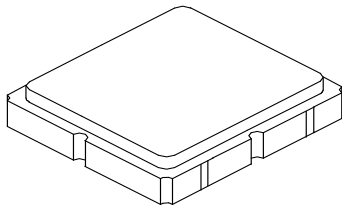

Dimension	mm			Inches		
	Min	Nom	Max	Min	Nom	Max
A	2.87	3.00	3.13	0.113	0.118	0.123
B	2.87	3.00	3.13	0.113	0.118	0.123
C	1.12	1.25	1.38	0.044	0.049	0.054
D	0.77	0.90	1.03	0.030	0.035	0.040
E	2.67	2.80	2.93	0.105	0.110	0.115
F	1.47	1.60	1.73	0.058	0.063	0.068
G	0.72	0.85	0.98	0.028	0.033	0.038
H	1.37	1.50	1.63	0.054	0.059	0.064
I	0.47	0.60	0.73	0.019	0.024	0.029
J	1.17	1.30	1.43	0.046	0.051	0.056

Electrical Connections

Connection		Terminals
Port 1	Single Ended Input	2
Port 2	Single Ended Output	5
	Ground	All others
Single Ended Operation Only		
Dot indicates Pin 1		

TOP VIEW

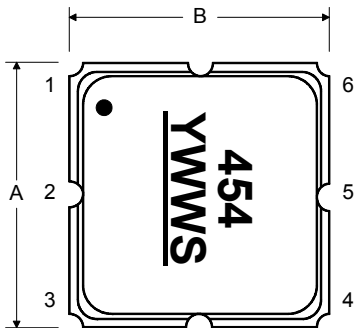

BOTTOM VIEW

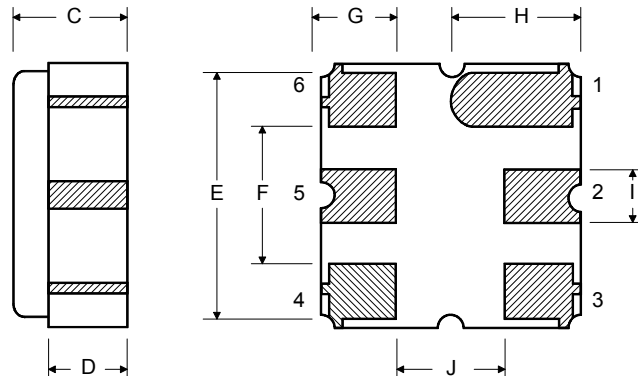

Recommended Reflow Profile

1. Preheating shall be fixed at 150~180°C for 60~90 seconds.
2. Ascending time to preheating temperature 150°C shall be 30 seconds min.
3. Heating shall be fixed at 220°C for 50~80 seconds and at 260°C+0/-5°C peak (10 seconds).
4. Time: 5 times maximum.

