

**SERIES:** VGD-30 | **DESCRIPTION:** AC-DC POWER SUPPLY

**FEATURES**

- up to 30 W continuous power
- universal input (85~264 Vac / 120~370 Vdc)
- dual output
- overload, over voltage, and short circuit protections
- UL/cUL and Intertek EN 60950-1 safety approvals
- built-in EMI filter
- efficiency up to 80%



| MODEL       | output voltage<br>(Vdc) | output current |            | output power <sup>1</sup><br>max<br>(W) | ripple and noise <sup>2</sup><br>max<br>(mVp-p) | efficiency<br>typ<br>(%) |
|-------------|-------------------------|----------------|------------|-----------------------------------------|-------------------------------------------------|--------------------------|
|             |                         | min<br>(A)     | max<br>(A) |                                         |                                                 |                          |
| VGD-30-D512 | 5                       | 0.3            | 4          | 30                                      | 80                                              | 79                       |
|             | 12                      | 0.3            | 2          |                                         | 120                                             |                          |
| VGD-30-D524 | 5                       | 0.3            | 4          | 30                                      | 80                                              | 80                       |
|             | 24                      | 0.2            | 1          |                                         | 240                                             |                          |

Note: 1. Maximum total combined power.  
2. Ripple & noise are measured at 20 MHz BW with 22  $\mu$ F aluminum electrolytic capacitor and 0.1  $\mu$ F ceramic capacitor on the output.

**PART NUMBER KEY**
**VGD-30 - DXXX**

Base Number

Output Voltage

## INPUT

| parameter      | conditions/description         | min | typ | max  | units |
|----------------|--------------------------------|-----|-----|------|-------|
| voltage        |                                | 85  |     | 264  | Vac   |
|                |                                | 120 |     | 370  | Vdc   |
| frequency      |                                | 47  |     | 63   | Hz    |
| input current  | 115 Vac                        |     |     | 0.6  | A     |
|                | 230 Vac                        |     |     | 0.35 | A     |
| inrush current | 115 Vac, full load, cold start |     |     | 30   | A     |
|                | 230 Vac, full load, cold start |     |     | 60   | A     |

## OUTPUT

| parameter               | conditions/description                         | min | typ   | max | units |
|-------------------------|------------------------------------------------|-----|-------|-----|-------|
| line regulation         |                                                |     | ±1    |     | %     |
| load regulation         |                                                |     | ±5    |     | %     |
| temperature coefficient |                                                |     | ±0.03 |     | %/°C  |
| hold-up time            | 115 Vac, full load                             |     | 10    |     | ms    |
|                         | 230 Vac, full load                             |     | 50    |     | ms    |
| adjustability           | adjustable with built-in trim pot <sup>1</sup> | -5  |       | +5  | %     |

Note: 1. Adjustment of 5 V output only.

## PROTECTIONS

| parameter                | conditions/description                          | min | typ | max | units |
|--------------------------|-------------------------------------------------|-----|-----|-----|-------|
| over voltage protection  | shut down and latch off, recover after restart. |     |     | 7   | V     |
| overload protection      | hiccup mode, automatically recovers             | 110 |     | 160 | %     |
| short circuit protection | continuous, automatically recovers              |     |     |     |       |

## SAFETY & COMPLIANCE

| parameter            | conditions/description                                                  | min     | typ   | max | units |
|----------------------|-------------------------------------------------------------------------|---------|-------|-----|-------|
| isolation voltage    | input to output                                                         |         | 3,000 |     | Vac   |
|                      | input to case                                                           |         | 1,500 |     | Vac   |
|                      | output to case                                                          |         | 500   |     | Vac   |
| isolation resistance | input to output at 500 Vdc at 25°C                                      | 100     |       |     | MΩ    |
| safety approvals     | UL 60950-1, Intertek EN 60950-1                                         |         |       |     |       |
| EMI/EMC              | EN 55022 (CISPR22) Class B, EN 61000-3-2,-3,-4-2,3,4,5,6,8,11; EN 55024 |         |       |     |       |
| leakage current      | at 240 Vac                                                              |         |       | 3.5 | mA    |
| MTBF                 | MIL-HDBK-217F(25°C)                                                     | 300,000 |       |     | hrs   |
| RoHS compliant       | yes                                                                     |         |       |     |       |

## ENVIRONMENTAL

| parameter             | conditions/description | min | typ | max | units |
|-----------------------|------------------------|-----|-----|-----|-------|
| operating temperature | see derating curve     | -10 |     | 60  | °C    |
| storage temperature   |                        | -20 |     | 85  | °C    |
| operating humidity    | non-condensing         | 20  |     | 90  | %     |
| storage humidity      |                        | 10  |     | 95  | %     |

## MECHANICAL

| parameter      | conditions/description                         | min | typ | max | units |
|----------------|------------------------------------------------|-----|-----|-----|-------|
| dimensions     | 3.9 x 3.8 x 1.4 (99 x 97 x 36 mm)              |     |     |     | inch  |
| cooling method | free air convection (see derating curve below) |     |     |     |       |
| weight         |                                                |     | 328 |     | g     |

## DERATING CURVES

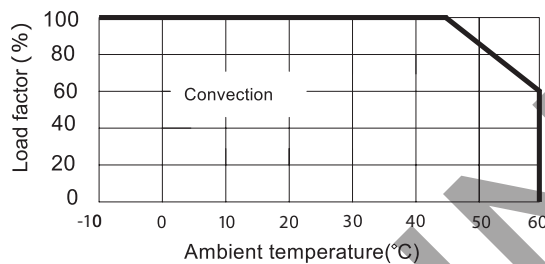

## MECHANICAL DRAWING

units mm[inches]  
 tolerance:  
 ±0.3mm unless otherwise specified

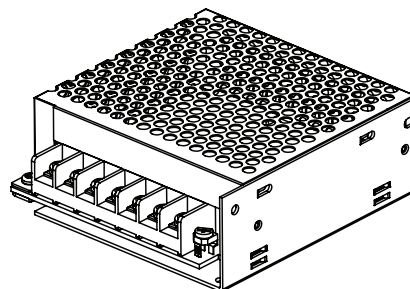
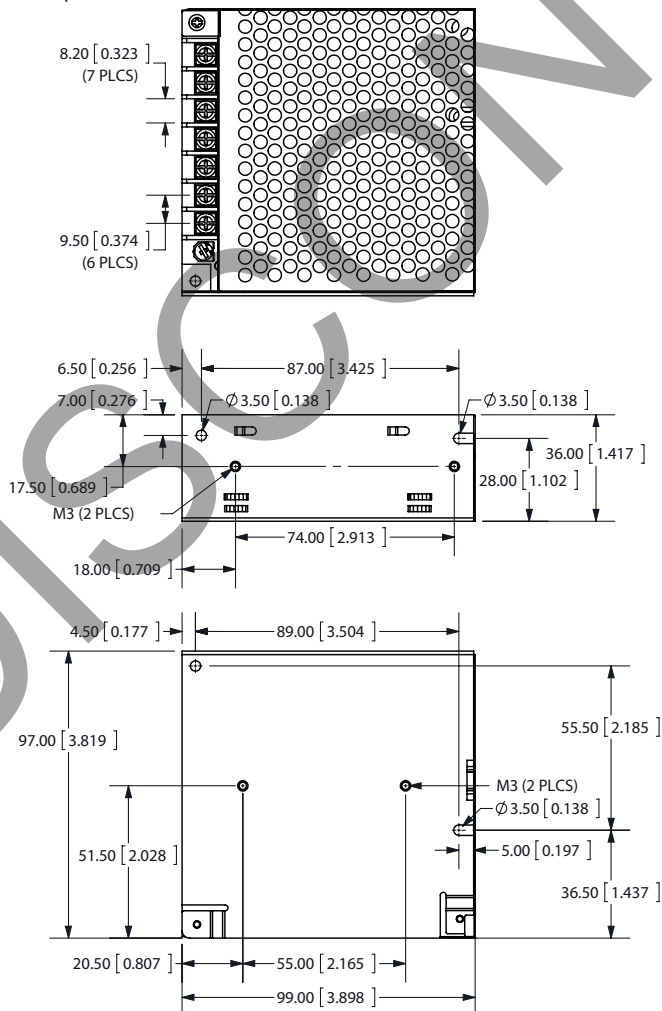

| PIN CONNECTIONS |            |
|-----------------|------------|
| Pin             | Function   |
| 1               | ac line    |
| 2               | ac natural |
| 3               | FG $\perp$ |
| 4               | COM        |
| 5               | +V2        |
| 6               | COM        |
| 7               | +V1        |

## REVISION HISTORY

| rev. | description                                      | date       |
|------|--------------------------------------------------|------------|
| 1.0  | initial release                                  | 10/26/2011 |
| 1.01 | updated capacitor values for ripple measurements | 04/20/2012 |
| 1.02 | V-Infinity branding removed                      | 08/21/2012 |
| 1.03 | added minimum current requirements               | 11/04/2013 |
| 1.04 | updated datasheet                                | 07/10/2018 |

The revision history provided is for informational purposes only and is believed to be accurate.



**Headquarters**  
20050 SW 112th Ave.  
Tualatin, OR 97062  
**800.275.4899**

Fax 503.612.2383  
**cui.com**  
techsupport@cui.com

CUI offers a two (2) year limited warranty. Complete warranty information is listed on our website.

CUI reserves the right to make changes to the product at any time without notice. Information provided by CUI is believed to be accurate and reliable. However, no responsibility is assumed by CUI for its use, nor for any infringements of patents or other rights of third parties which may result from its use.

CUI products are not authorized or warranted for use as critical components in equipment that requires an extremely high level of reliability. A critical component is any component of a life support device or system whose failure to perform can be reasonably expected to cause the failure of the life support device or system, or to affect its safety or effectiveness.