

# CGH60015D

15 W, 6.0 GHz, GaN HEMT Die

## Description

Cree's CGH60015D is a gallium nitride (GaN) High Electron Mobility Transistor (HEMT). GaN has superior properties compared to silicon or gallium arsenide, including higher breakdown voltage, higher saturated electron drift velocity, and higher thermal conductivity. GaN HEMTs offer greater power density and wider bandwidths compared to Si and GaAs transistors.

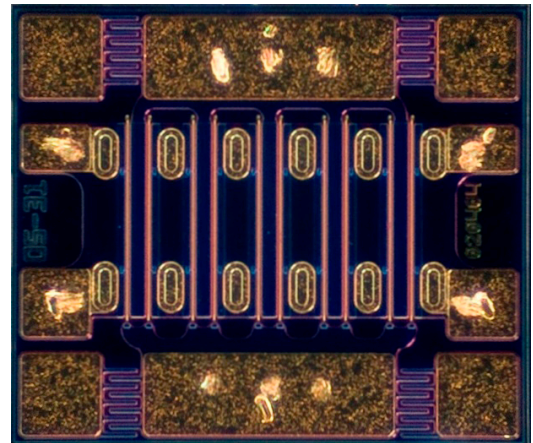

PN: CGH60015D

## Features

- 15 dB Typical Small Signal Gain at 4 GHz
- 12 dB Typical Small Signal Gain at 6 GHz
- 15 W Typical  $P_{SAT}$
- 28 V Operation
- High Breakdown Voltage
- High Temperature Operation
- Up to 6 GHz Operation
- High Efficiency

## Applications

- 2-Way Private Radio
- Broadband Amplifiers
- Cellular Infrastructure
- Test Instrumentation
- Class A, AB, Linear amplifiers suitable for OFDM, W-CDMA, EDGE, CDMA waveforms



## Packaging Information

- Bare die are shipped in Gel-Pak® containers
- Non-adhesive tacky membrane immobilizes die during shipment

 Large Signal Models Available for ADS and MWO

**RoHS**  
COMPLIANT



### Absolute Maximum Ratings (not simultaneous) at 25 °C

Parameter	Symbol	Rating	Units	Conditions
Drain-source Voltage	$V_{DSS}$	120	VDC	25 °C
Gate-source Voltage	$V_{GS}$	-10, +2	VDC	25 °C
Storage Temperature	$T_{STG}$	-65, +150	°C	
Operating Junction Temperature	$T_J$	225	°C	
Maximum Forward Gate Current	$I_{GMAX}$	4.0	mA	25 °C
Maximum Drain Current <sup>1</sup>	$I_{DMAX}$	1.5	A	25 °C
Thermal Resistance, Junction to Case (packaged) <sup>2</sup>	$R_{\theta JC}$	8.0	°C/W	
Thermal Resistance, Junction to Case (die only)	$R_{\theta JC}$	5.1	°C/W	85 °C
Mounting Temperature (30 seconds)	$T_S$	320	°C	30 seconds

Notes:

<sup>1</sup> Current limit for long term, reliable operation

<sup>2</sup> Eutectic die attach using 80/20 AuSn mounted to a 40 mil thick CuMoCu carrier

### Electrical Characteristics (Frequency = 4 GHz unless otherwise stated; TC = 25 °C)

Characteristics	Symbol	Min.	Typ.	Max.	Units	Conditions
<b>DC Characteristics</b>						
Gate Threshold Voltage	$V_{GS(TH)}$	-3.8	-3.0	-2.3	V	$V_{DS} = 10\text{ V}, I_D = 3.6\text{ mA}$
Gate Quiescent Voltage	$V_{GS(Q)}$	-	-2.7	-	V <sub>DC</sub>	$V_{DD} = 28\text{ V}, I_{DQ} = 100\text{ mA}$
Drain Current	$I_{DS}$	2.9	3.5	-	A	$V_{DS} = 6.0\text{ V}, V_{GS} = 2.0\text{ V}$
Drain-Source Breakdown Voltage	$V_{BD}$	84	-	-	V	$V_{GS} = -8\text{ V}, I_D = 3.6\text{ mA}$
On Resistance	$R_{ON}$	-	1.0	-	Ω	$V_{DS} = 0.1\text{ V}$
Gate Forward Voltage	$V_{G-ON}$	-	1.9	-	V	$I_{GS} = 3.6\text{ mA}$
<b>RF Characteristics</b>						
Small Signal Gain	$G_{SS}$	-	15	-	dB	$V_{DD} = 28\text{ V}, I_{DQ} = 100\text{ mA}$
Saturated Power Output <sup>1</sup>	$P_{SAT}$	-	15	-	W	$V_{DD} = 28\text{ V}, I_{DQ} = 100\text{ mA}$
Drain Efficiency <sup>2</sup>	$\eta$	-	65	-	%	$V_{DD} = 28\text{ V}, I_{DQ} = 100\text{ mA}, P_{SAT} = 15\text{ W}$
Intermodulation Distortion	IM3	-	-30	-	dBc	$V_{DD} = 28\text{ V}, I_{DQ} = 100\text{ mA}, P_{OUT} = 15\text{ W PEP}$
Output Mismatch Stress	VSWR	-	-	10 : 1	Y	No damage at all phase angles, $V_{DD} = 28\text{ V}, I_{DQ} = 100\text{ mA},$ $P_{OUT} = 15\text{ W CW}$
<b>Dynamic Characteristics</b>						
Input Capacitance	$C_{GS}$	-	4.1	-	pF	$V_{DS} = 28\text{ V}, V_{GS} = -8\text{ V}, f = 1\text{ MHz}$
Output Capacitance	$C_{DS}$	-	0.9	-	pF	$V_{DS} = 28\text{ V}, V_{GS} = -8\text{ V}, f = 1\text{ MHz}$
Feedback Capacitance	$C_{GD}$	-	0.2	-	pF	$V_{DS} = 28\text{ V}, V_{GS} = -8\text{ V}, f = 1\text{ MHz}$

Notes:

<sup>1</sup>  $P_{SAT}$  is defined as  $I_G = 0.4\text{ mA}$

<sup>2</sup> Drain Efficiency =  $P_{OUT} / P_{DC}$

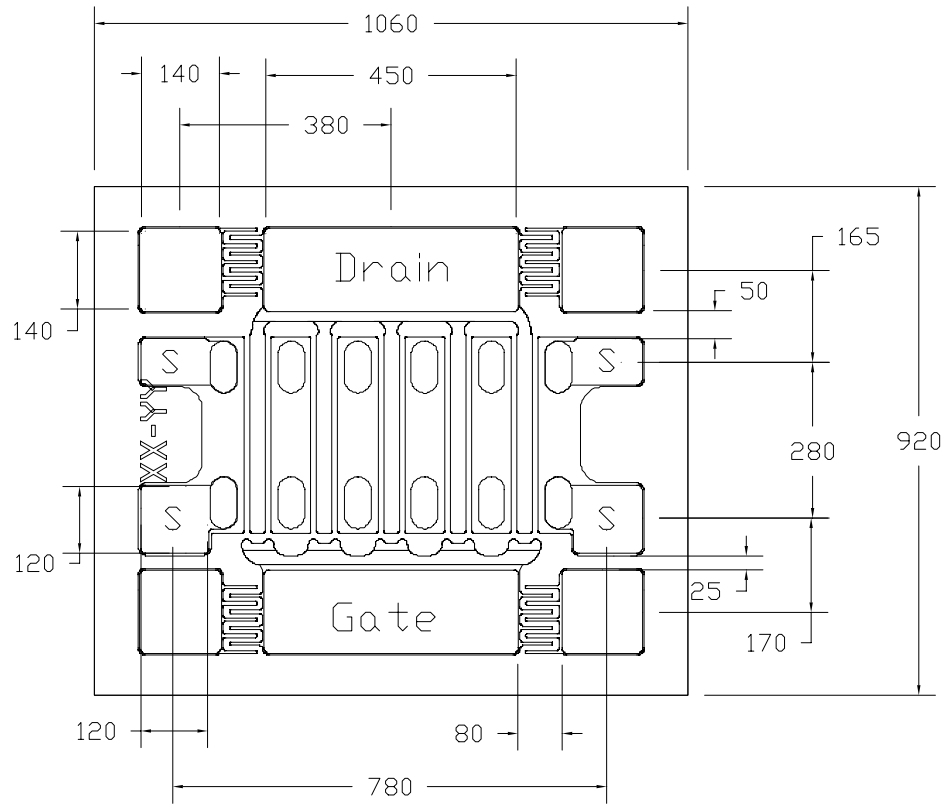
**DIE Dimensions (units in microns)**

Overall die size 1060 x 920 (+0/-50) microns, die thickness 100 (+/- 10) microns.  
All Gate and Drain pads must be wire bonded for electrical connection.

**Assembly Notes**

- Recommended solder is AuSn (80/20) solder. Refer to Cree's website for the Eutectic Die Bond Procedure application note at [http://www.cree.com/products/wireless\\_documents.asp](http://www.cree.com/products/wireless_documents.asp)
- Vacuum collet is the preferred method of pick-up
- The backside of the die is the Source (ground) contact
- Die back side gold plating is 5 microns thick minimum
- Thermosonic ball or wedge bonding are the preferred connection methods
- Gold wire must be used for connections
- Use the die label (XX-YY) for correct orientation



**Typical Performance**

**Simulated Maximum Available Gain and K Factor of the CGH60015D**

$V_{DD} = 28\text{ V}, I_{DQ} = 200\text{ mA}$

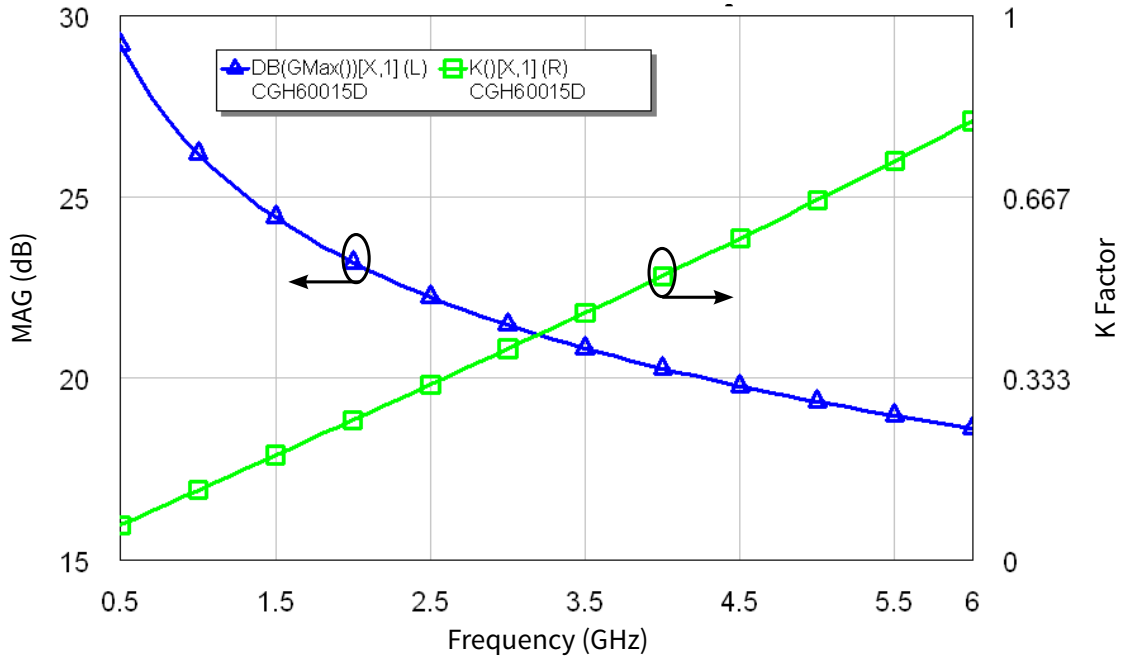

Intrinsic die parameters - reference planes at centers of gate and drain bonding pads. No wire bonds assumed.

**Typical Noise Performance**

**Simulated Minimum Noise Figure and Noise Resistance vs Frequency of the CGH60015D**

$V_{DD} = 28\text{ V}, I_{DQ} = 200\text{ mA}$

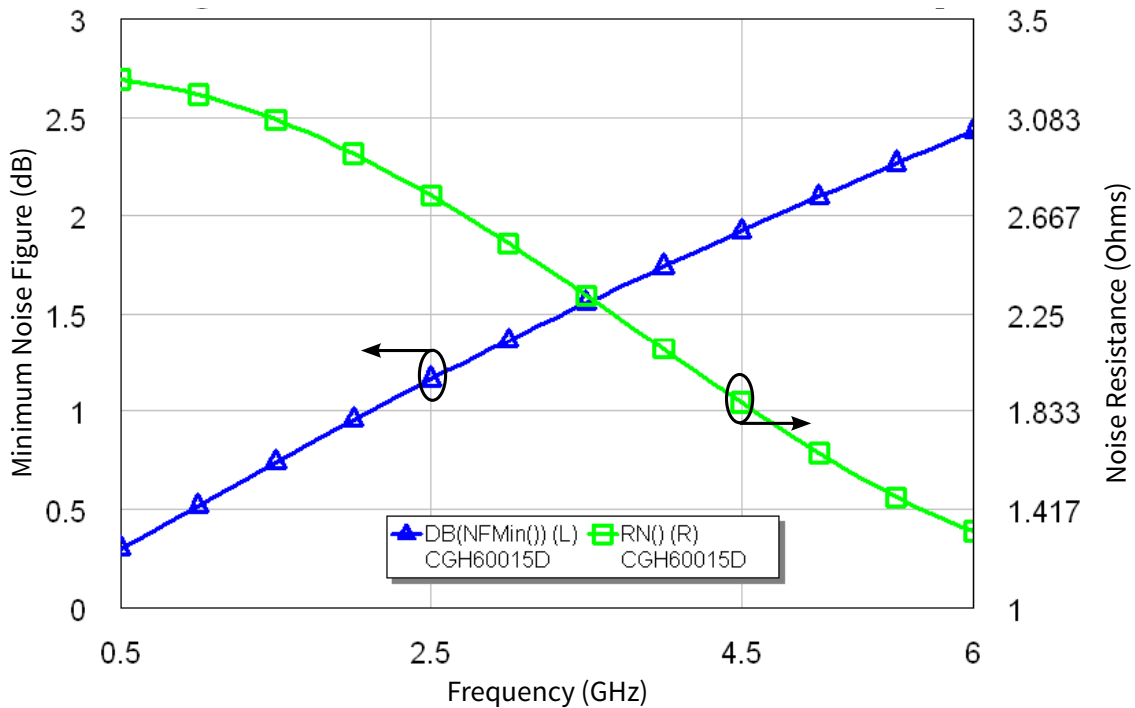

## Typical Die S-Parameters (Small Signal, $V_{DS} = 28\text{ V}$ , $I_{DQ} = 100\text{ mA}$ , magnitude/angle)

Frequency	Mag S11	Ang S11	Mag S21	Ang S21	Mag S12	Ang S12	Mag S22	Ang S22
500 MHz	0.934	-119.01	17.60	114.24	0.027	25.07	0.332	-87.18
600 MHz	0.929	-127.83	15.22	108.93	0.028	19.92	0.316	-94.45
700 MHz	0.925	-134.59	13.36	104.63	0.029	15.79	0.307	-100.05
800 MHz	0.923	-139.91	11.87	101.05	0.029	12.37	0.302	-104.41
900 MHz	0.921	-144.20	10.66	97.98	0.029	9.46	0.300	-107.86
1.0 GHz	0.920	-147.72	9.66	95.28	0.030	6.93	0.300	-110.62
1.1 GHz	0.919	-150.66	8.82	92.86	0.030	4.68	0.302	-112.85
1.2 GHz	0.918	-153.16	8.11	90.66	0.030	2.64	0.305	-114.69
1.3 GHz	0.918	-155.31	7.50	88.64	0.030	0.78	0.309	-116.23
1.4 GHz	0.918	-157.17	6.96	86.75	0.030	-0.94	0.315	-117.53
1.5 GHz	0.917	-158.81	6.50	84.98	0.030	-2.54	0.320	-118.66
1.6 GHz	0.917	-160.27	6.09	83.30	0.030	-4.05	0.327	-119.65
1.7 GHz	0.918	-161.56	5.72	81.70	0.030	-5.49	0.334	-120.54
1.8 GHz	0.918	-162.73	5.39	80.17	0.030	-6.85	0.341	-121.35
1.9 GHz	0.918	-163.79	5.10	78.70	0.030	-8.16	0.349	-122.09
2.0 GHz	0.918	-164.75	4.83	77.28	0.029	-9.42	0.357	-122.79
2.1 GHz	0.918	-165.64	4.59	75.90	0.029	-10.63	0.365	-123.45
2.2 GHz	0.919	-166.45	4.37	74.56	0.029	-11.80	0.373	-124.09
2.3 GHz	0.919	-167.20	4.16	73.26	0.029	-12.94	0.381	-124.71
2.4 GHz	0.919	-167.90	3.98	71.99	0.029	-14.04	0.390	-125.30
2.5 GHz	0.920	-168.56	3.80	70.74	0.029	-15.12	0.398	-125.89
2.6 GHz	0.920	-169.17	3.64	69.53	0.029	-16.17	0.407	-126.47
2.7 GHz	0.921	-169.75	3.49	68.34	0.029	-17.20	0.415	-127.05
2.8 GHz	0.921	-170.29	3.35	67.17	0.028	-18.20	0.424	-127.62
2.9 GHz	0.921	-170.80	3.22	66.02	0.028	-19.18	0.433	-128.18
3.0 GHz	0.922	-171.29	3.10	64.89	0.028	-20.14	0.441	-128.75
3.2 GHz	0.923	-172.20	2.88	62.69	0.028	-22.01	0.458	-129.87
3.4 GHz	0.924	-173.02	2.68	60.56	0.028	-23.81	0.475	-130.99
3.6 GHz	0.925	-173.79	2.51	58.49	0.027	-25.56	0.492	-132.10
3.8 GHz	0.926	-174.50	2.35	56.47	0.027	-27.24	0.508	-133.22
4.0 GHz	0.927	-175.16	2.21	54.51	0.027	-28.87	0.524	-134.33
4.2 GHz	0.928	-175.79	2.08	52.59	0.026	-30.45	0.539	-135.44
4.4 GHz	0.929	-176.39	1.96	50.72	0.026	-31.99	0.554	-136.54
4.6 GHz	0.930	-176.95	1.85	48.90	0.025	-33.48	0.568	-137.63
4.8 GHz	0.931	-177.50	1.75	47.12	0.025	-34.93	0.582	-138.71
5.0 GHz	0.933	-178.02	1.66	45.37	0.025	-36.34	0.596	-139.78
5.2 GHz	0.934	-178.52	1.57	43.67	0.024	-37.71	0.609	-140.85
5.4 GHz	0.935	-179.01	1.50	42.01	0.024	-39.04	0.622	-141.90
5.6 GHz	0.936	-179.48	1.42	40.38	0.023	-40.33	0.634	-142.93
5.8 GHz	0.937	-179.94	1.36	38.78	0.023	-41.59	0.646	-143.96
6.0 GHz	0.938	-179.61	1.29	37.22	0.023	-42.82	0.657	-144.97

To download the s-parameters in s2p format, go to the [CGH60015D Product page](#) and click on the documentation tab.

## Typical Die S-Parameters (Small Signal, $V_{DS} = 28\text{ V}$ , $I_{DQ} = 200\text{ mA}$ , magnitude / angle)

Frequency	Mag S11	Ang S11	Mag S21	Ang S21	Mag S12	Ang S12	Mag S22	Ang S22
500 MHz	0.938	-125.92	18.76	111.46	0.022	22.32	0.300	-109.34
600 MHz	0.933	-134.06	16.11	106.58	0.023	17.60	0.296	-116.39
700 MHz	0.931	-140.21	14.07	102.67	0.024	13.87	0.295	-121.49
800 MHz	0.929	-145.02	12.46	99.42	0.024	10.79	0.295	-125.23
900 MHz	0.928	-148.86	11.16	96.65	0.024	8.19	0.297	-128.01
1.0 GHz	0.927	-152.01	10.10	94.21	0.024	5.93	0.299	-130.10
1.1 GHz	0.926	-154.64	9.21	92.03	0.024	3.92	0.303	-131.68
1.2 GHz	0.926	-156.86	8.46	90.05	0.024	2.11	0.307	-132.90
1.3 GHz	0.926	-158.77	7.82	88.22	0.024	0.45	0.312	-133.83
1.4 GHz	0.925	-160.43	7.26	86.52	0.024	-1.08	0.317	-134.56
1.5 GHz	0.925	-161.89	6.78	84.91	0.024	-2.51	0.322	-135.14
1.6 GHz	0.925	-163.19	6.35	83.39	0.024	-3.86	0.328	-135.60
1.7 GHz	0.925	-164.34	5.97	81.94	0.024	-5.14	0.334	-135.98
1.8 GHz	0.925	-165.38	5.63	80.54	0.024	-6.36	0.340	-136.29
1.9 GHz	0.926	-166.33	5.32	79.20	0.024	-7.53	0.347	-136.56
2.0 GHz	0.926	-167.19	5.05	77.90	0.024	-8.66	0.354	-136.80
2.1 GHz	0.926	-167.98	4.80	76.64	0.024	-9.75	0.361	-137.02
2.2 GHz	0.926	-168.71	4.57	75.42	0.024	-10.80	0.368	-137.22
2.3 GHz	0.926	-169.39	4.36	74.22	0.024	-11.82	0.375	-137.42
2.4 GHz	0.927	-170.02	4.16	73.05	0.024	-12.82	0.382	-137.61
2.5 GHz	0.927	-170.61	3.98	71.91	0.024	-13.79	0.389	-137.81
2.6 GHz	0.927	-171.16	3.82	70.79	0.024	-14.74	0.397	-138.01
2.7 GHz	0.927	-171.68	3.66	69.69	0.024	-15.67	0.404	-138.22
2.8 GHz	0.928	-172.17	3.52	68.60	0.023	-16.58	0.412	-138.43
2.9 GHz	0.928	-172.64	3.39	67.54	0.023	-17.47	0.419	-138.66
3.0 GHz	0.928	-173.08	3.26	66.49	0.023	-18.34	0.427	-138.89
3.2 GHz	0.929	-173.90	3.03	64.44	0.023	-20.05	0.442	-139.38
3.4 GHz	0.930	-174.66	2.83	62.45	0.023	-21.69	0.457	-139.91
3.6 GHz	0.931	-175.36	2.65	60.50	0.022	-23.29	0.471	-140.48
3.8 GHz	0.931	-176.01	2.49	58.61	0.022	-24.84	0.486	-141.08
4.0 GHz	0.932	-176.62	2.34	56.75	0.022	-26.35	0.500	-141.71
4.2 GHz	0.933	-177.20	2.21	54.94	0.022	-27.81	0.515	-142.37
4.4 GHz	0.934	-177.75	2.08	53.17	0.021	-29.24	0.528	-143.06
4.6 GHz	0.935	-178.27	1.97	51.43	0.021	-30.63	0.542	-143.76
4.8 GHz	0.936	-178.77	1.87	49.73	0.021	-31.98	0.555	-144.48
5.0 GHz	0.936	-179.26	1.77	48.06	0.021	-33.30	0.568	-145.22
5.2 GHz	0.937	-179.72	1.69	46.42	0.020	-34.59	0.581	-145.96
5.4 GHz	0.938	-179.83	1.61	44.81	0.020	-35.85	0.593	-146.72
5.6 GHz	0.939	-179.39	1.53	43.24	0.020	-37.07	0.605	-147.48
5.8 GHz	0.940	-178.96	1.46	41.69	0.019	-38.27	0.616	-148.24
6.0 GHz	0.941	-178.54	1.40	40.17	0.019	-39.43	0.627	-149.01

To download the s-parameters in s2p format, go to the [CGH60015D Product page](#) and click on the documentation tab.



## Typical Die S-Parameters (Small Signal, $V_{DS} = 28\text{ V}$ , $I_{DQ} = 500\text{ mA}$ , magnitude / angle)

Frequency	Mag S11	Ang S11	Mag S21	Ang S21	Mag S12	Ang S12	Mag S22	Ang S22
500 MHz	0.940	-129.62	18.94	109.96	0.020	20.83	0.303	-122.59
600 MHz	0.936	-137.35	16.21	105.32	0.021	16.37	0.304	-128.82
700 MHz	0.934	-143.16	14.12	101.63	0.021	12.86	0.306	-133.18
800 MHz	0.933	-147.68	12.48	98.57	0.022	9.97	0.309	-136.30
900 MHz	0.932	-151.28	11.17	95.95	0.022	7.54	0.312	-138.55
1.0 GHz	0.931	-154.23	10.10	93.66	0.022	5.42	0.315	-140.20
1.1 GHz	0.930	-156.68	9.21	91.60	0.022	3.55	0.319	-141.41
1.2 GHz	0.930	-158.76	8.46	89.74	0.022	1.85	0.323	-142.30
1.3 GHz	0.930	-160.55	7.81	88.01	0.022	0.31	0.327	-142.95
1.4 GHz	0.930	-162.10	7.26	86.40	0.022	-1.12	0.332	-143.43
1.5 GHz	0.930	-163.47	6.77	84.88	0.022	-2.46	0.337	-143.77
1.6 GHz	0.930	-164.68	6.34	83.45	0.022	-3.72	0.342	-144.01
1.7 GHz	0.930	-165.76	5.96	82.07	0.022	-4.92	0.347	-144.19
1.8 GHz	0.930	-166.74	5.62	80.75	0.022	-6.06	0.353	-144.30
1.9 GHz	0.930	-167.62	5.32	79.48	0.022	-7.16	0.358	-144.38
2.0 GHz	0.930	-168.43	5.04	78.24	0.022	-8.21	0.364	-144.44
2.1 GHz	0.930	-169.18	4.79	77.05	0.022	-9.23	0.370	-144.48
2.2 GHz	0.930	-169.86	4.57	75.88	0.022	-10.22	0.376	-144.51
2.3 GHz	0.931	-170.50	4.36	74.74	0.022	-11.18	0.383	-144.53
2.4 GHz	0.931	-171.10	4.16	73.63	0.021	-12.12	0.389	-144.56
2.5 GHz	0.931	-171.65	3.99	72.54	0.021	-13.03	0.395	-144.59
2.6 GHz	0.931	-172.17	3.82	71.46	0.021	-13.92	0.402	-144.63
2.7 GHz	0.931	-172.66	3.67	70.41	0.021	-14.80	0.408	-144.68
2.8 GHz	0.932	-173.13	3.53	69.38	0.021	-15.65	0.415	-144.74
2.9 GHz	0.932	-173.57	3.39	68.36	0.021	-16.49	0.422	-144.80
3.0 GHz	0.932	-173.99	3.27	67.35	0.021	-17.32	0.428	-144.89
3.2 GHz	0.933	-174.77	3.04	65.39	0.021	-18.93	0.442	-145.08
3.4 GHz	0.933	-175.49	2.84	63.47	0.021	-20.49	0.455	-145.33
3.6 GHz	0.934	-176.16	2.66	61.60	0.020	-22.00	0.469	-145.63
3.8 GHz	0.935	-176.78	2.50	59.77	0.020	-23.47	0.482	-145.97
4.0 GHz	0.935	-177.36	2.36	57.98	0.020	-24.90	0.495	-146.36
4.2 GHz	0.936	-177.92	2.22	56.22	0.020	-26.30	0.508	-146.78
4.4 GHz	0.937	-178.44	2.10	54.50	0.019	-27.66	0.521	-147.24
4.6 GHz	0.937	-178.95	1.99	52.81	0.019	-28.99	0.534	-147.73
4.8 GHz	0.938	-179.43	1.89	51.16	0.019	-30.28	0.546	-148.25
5.0 GHz	0.939	-179.89	1.80	49.53	0.019	-31.55	0.558	-148.80
5.2 GHz	0.940	-179.66	1.71	47.93	0.019	-32.78	0.570	-149.36
5.4 GHz	0.940	-179.22	1.63	46.36	0.018	-33.99	0.582	-149.95
5.6 GHz	0.941	-178.80	1.55	44.82	0.018	-35.17	0.593	-150.55
5.8 GHz	0.942	-178.38	1.48	43.30	0.018	-36.32	0.604	-151.16
6.0 GHz	0.942	-177.98	1.42	41.81	0.018	-37.45	0.615	-151.78

To download the s-parameters in s2p format, go to the [CGH60015D Product page](#) and click on the documentation tab.



## Electrostatic Discharge (ESD) Classifications

Parameter	Symbol	Class	Test Methodology
Human Body Model	HBM	1A (> 250 V)	JEDEC JESD22 A114-D
Charge Device Model	CDM	II (200 < 500 V)	JEDEC JESD22 C101-C

## Product Ordering Information

Order Number	Description	Unit of Measure
CGH60015D	GaN HEMT bare die	Each





For more information, please contact:

4600 Silicon Drive  
Durham, North Carolina, USA 27703  
[www.wolfspeed.com/RF](http://www.wolfspeed.com/RF)

Sales Contact  
[RFSales@cree.com](mailto:RFSales@cree.com)

## Notes

---

### Disclaimer

Specifications are subject to change without notice. Cree, Inc. believes the information contained within this data sheet to be accurate and reliable. However, no responsibility is assumed by Cree for any infringement of patents or other rights of third parties which may result from its use. No license is granted by implication or otherwise under any patent or patent rights of Cree. Cree makes no warranty, representation or guarantee regarding the suitability of its products for any particular purpose. “Typical” parameters are the average values expected by Cree in large quantities and are provided for information purposes only. These values can and do vary in different applications and actual performance can vary over time. All operating parameters should be validated by customer’s technical experts for each application. Cree products are not designed, intended or authorized for use as components in applications intended for surgical implant into the body or to support or sustain life, in applications in which the failure of the Cree product could result in personal injury or death or in applications for planning, construction, maintenance or direct operation of a nuclear facility.