

8V to 35V, 1.5A 1ch Buck Converter with Integrated FET

BD9701FP BD9701CP-V5 BD9701T BD9701T-V5

General Description

The BD9701xx is a series of step-down switching regulators capable of PWM operation. It has a built-in P-Channel MOSFET making its efficiency high at small loads. It has lower power consumption because it is made under Bi-CMOS process. Its operating current is only 4mA (Typ) and standby current is 0μA (Typ).

Key Specifications

■ Input Voltage Range:	8V to 35V
■ Output Voltage Range:	1.0V to 32V
■ Output Current:	1.5A(Max)
■ Switching Frequency:	100kHz(Typ)
■ FET ON-Resistance:	1.0Ω(Typ)
■ Standby Current:	0μA (Typ)
■ Operating Temperature Range:	-40°C to +85°C

Features

- Built-In P-Channel MOSFET for High Efficiency
- Adjustable Output Voltage Via External Resistors
- Built-In Over-Current Protection and Thermal Shutdown Circuits
- ON/OFF Control Via STBY Pin

Applications

TVs, Printers, DVD Players, Projectors, Gaming Devices, PCs, Car Audio/Navigation Systems, ETCs, Communication Equipment, AV Products, Office Equipment, Industrial Devices, and more.

Packages

W(Typ) x D(Typ) x H(Max)

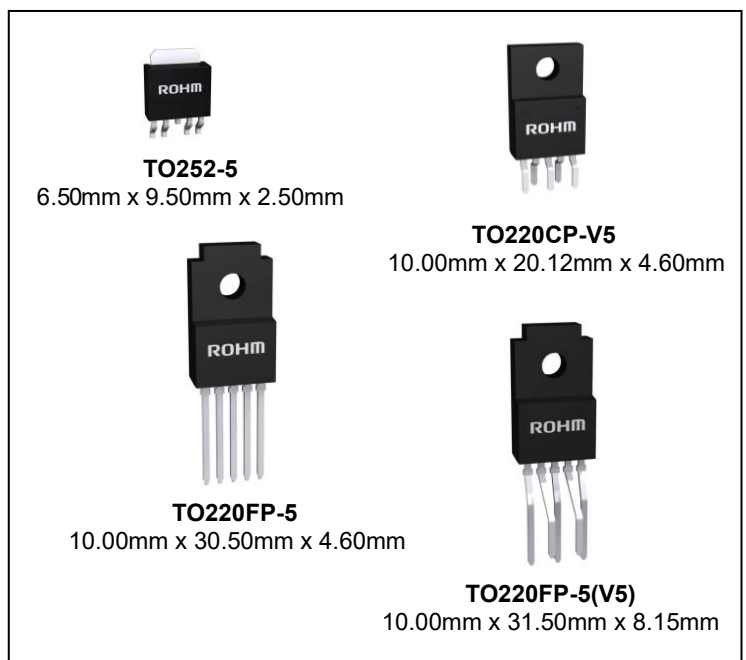

Typical Application Circuit

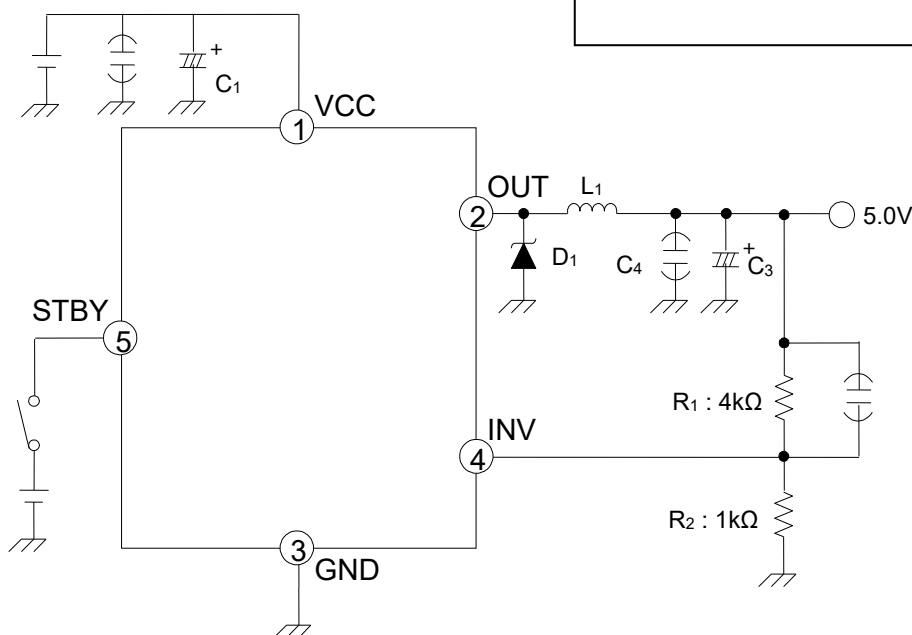

Figure 1. Typical Application Circuit

Block Diagram

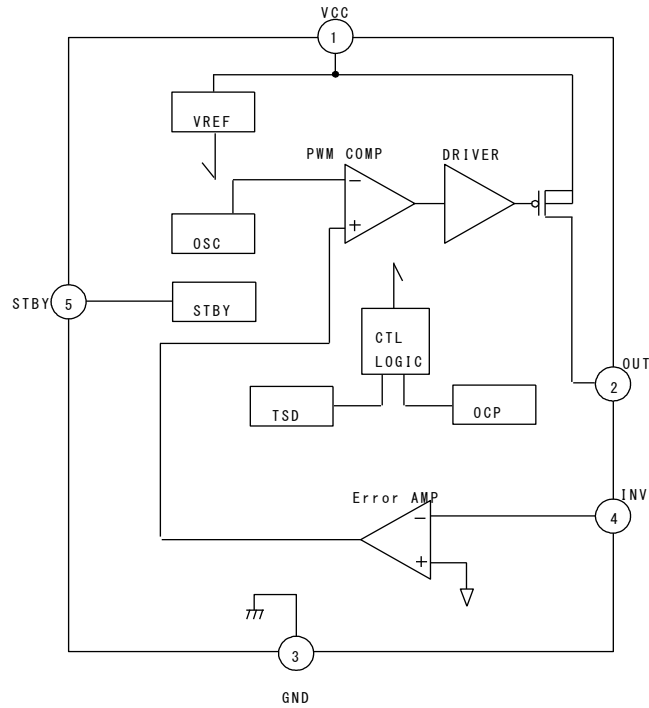
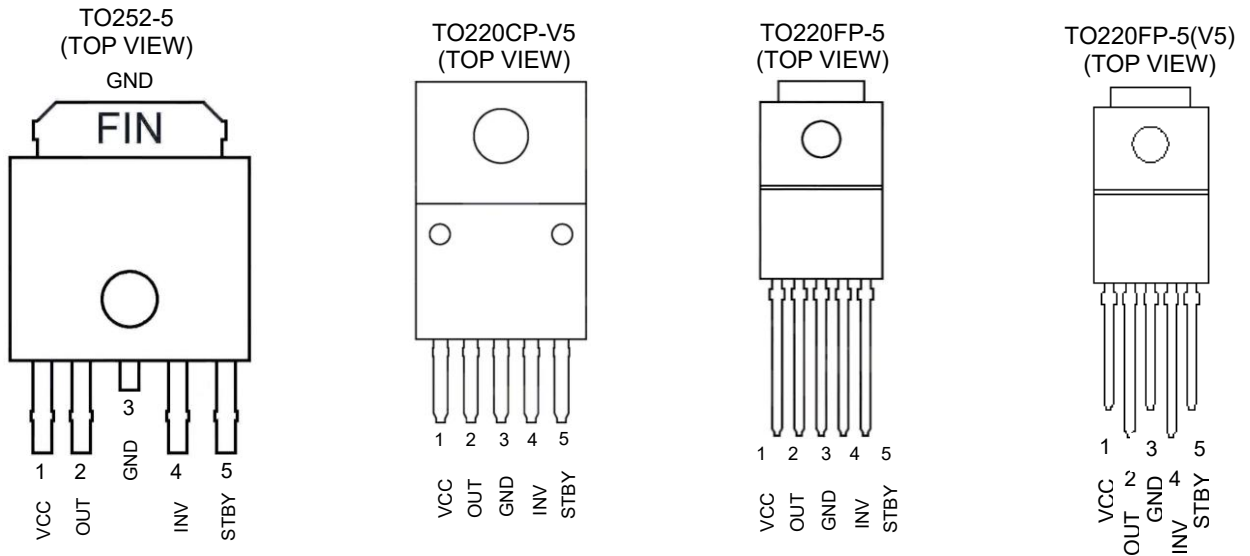

Figure 2. Block Diagram

Pin Configuration



Pin Description

Pin No.	Pin Name	Function
1	VCC	Power supply pin
2	OUT	Internal Pch FET drain pin
3,FIN ^(Note 1)	GND	Ground
4	INV	Output voltage feedback pin
5	STBY	ON/OFF control pin

(Note 1) FIN is assigned in the case of TO252-5.

Absolute Maximum Ratings (Ta=25°C)

Parameter	Symbol	Rating	Unit
Supply Voltage (VCC-GND)	V _{CC}	36	V
STBY-GND	V _{STBY}	36	V
OUT-GND	V _{OUT}	36	V
INV-GND	V _{INV}	10	V
Maximum Output Current	I _{OUT}	1.5	A
Power Dissipation	Pd	0.8 (Note 2)	W
		2 (Note 3)	
Operating Temperature	Topr	-40 to +85	°C
Storage Temperature Range	Tstg	-55 to +150	°C

(Note 2) Without external heat sink, reduced by 6.4mW/°C over 25°C

(Note 3) Without external heat sink, reduced by 16.0mW/°C over 25°C

Reduced by 160mW/°C, when mounted on ideal size heatsink (Tc = Ta)

Caution: Operating the IC over the absolute maximum ratings may damage the IC. The damage can either be a short circuit between pins or an open circuit between pins and internal circuitry. Therefore, it is important to consider circuit protection measures, such as adding a fuse, in case the IC is operated over the absolute maximum ratings.

Recommended Operating Conditions (Ta=-40°C to +85°C)

Parameter	Symbol	Limit			Unit
		Min	Typ	Max	
Input Voltage	V _{CC}	8.0 or V _{OUT} +3 (Note 4)	-	35.0	V
Output Voltage	V _{OUT}	1.0	-	32	V

(Note 4) The minimum value of an input voltage is the higher either 8.0V or V_{OUT}+3

Electrical Characteristics

(Unless otherwise noted, Ta=25°C, V_{CC}=12V, V_{OUT}=5V, V_{STBY}=3V)

Parameter	Symbol	Limit			Unit	Conditions	
		Min	Typ	Max			
Output ON-Resistance	R _{ON}	-	1.0	1.5	Ω	Design guarantee	
Efficiency	η	-	86	-	%	I _{OUT} =0.5A Design guarantee	
Switching Frequency	f _{OSC}	80	100	120	kHz		
Load Regulation	ΔV _{OUTLOAD}	-	10	40	mV	V _{CC} =20V, I _{OUT} =0.5A to 1.5A	
Line Regulation	ΔV _{OUTLINE}	-	40	100	mV	V _{CC} =10V to 30V, I _{OUT} =1.0A	
Over Current Protection Limit	I _{OC}	1.6	-	-	A		
INV Pin Threshold Voltage	V _{INV}	0.98	1.00	1.02	V		
INV Pin Threshold Voltage Thermal Variation	ΔV _{INV}	-	±0.5	-	%	T _j =0°C to 85°C Design guarantee	
INV Pin Input Current	I _{INV}	-	1	-	μA	V _{INV} =1.0V	
STBY Pin Threshold Voltage	ON	V _{STBYON}	2.0	-	36	V	
	OFF	V _{STBYOFF}	-0.3	-	+0.3	V	
STBY Pin Input Current	I _{STBY}	5	25	50	μA	V _{STBY} =3V	
Circuit Current	I _{CC}	-	4	12	mA		
Stand-by Current	I _{ST}	-	0	5	μA	V _{STBY} =0V	

Typical Performance Curves

(Unless otherwise specified: $T_a=25\text{deg}$, $V_{CC}=12\text{V}$, $V_{OUT}=5\text{V}$, $V_{STBY}=3\text{V}$)

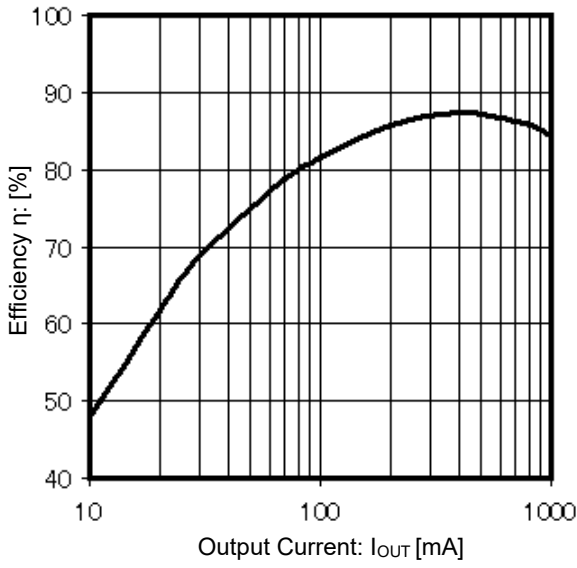

Figure 3. Efficiency vs Output Current

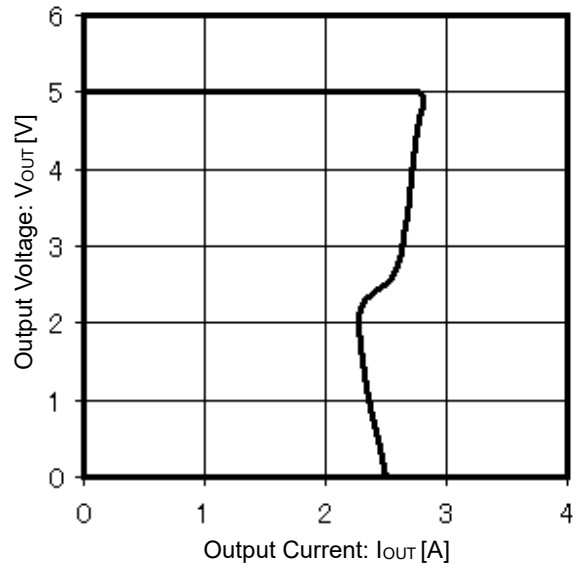

Figure 4. Output Voltage vs Output Current (OCP $V_{CC}=20\text{V}$)

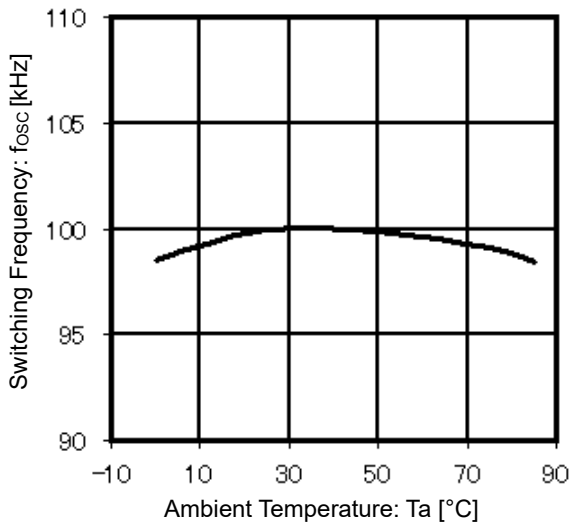

Figure 5. Switching Frequency vs Ambient Temperature

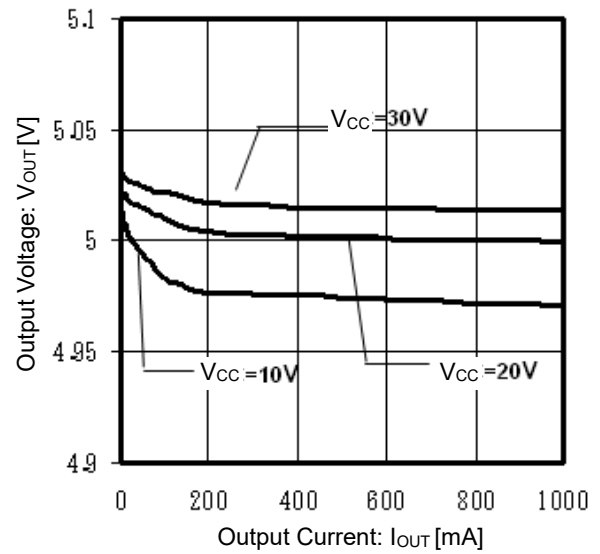

Figure 6. Output Voltage vs Output Current

Typical Performance Curves - continued

(Unless otherwise specified: $T_a=25\text{deg}$, $V_{CC}=12\text{V}$, $V_{OUT}=5\text{V}$, $V_{STBY}=3\text{V}$)

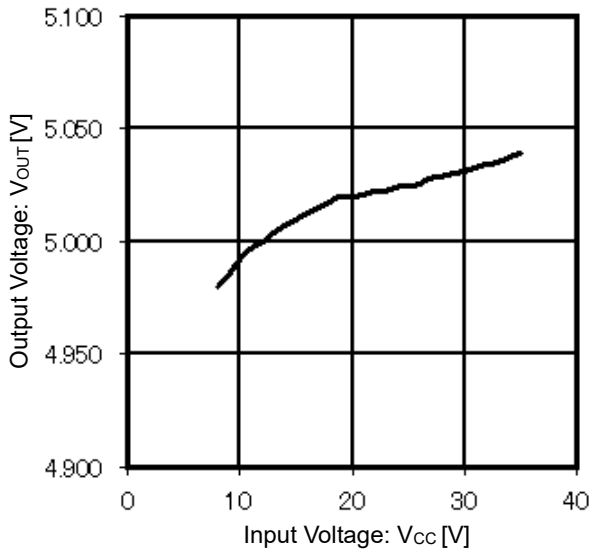

Figure 7. Output Voltage vs Input Voltage ($V_{OUT}=5\text{V}$, $R_{OUT}=5\Omega$)

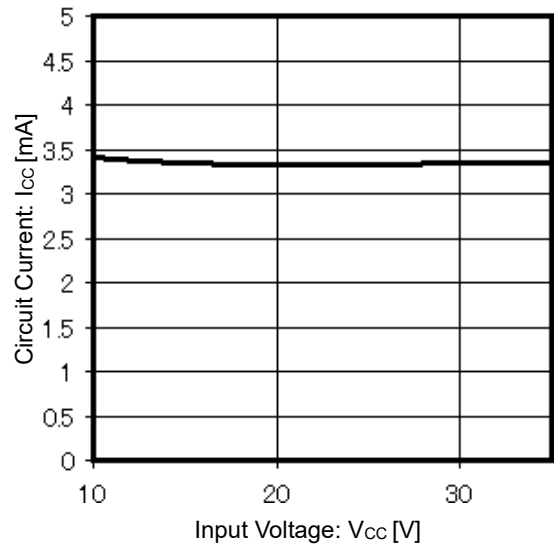

Figure 8. Circuit Current vs Input Voltage (No Load)

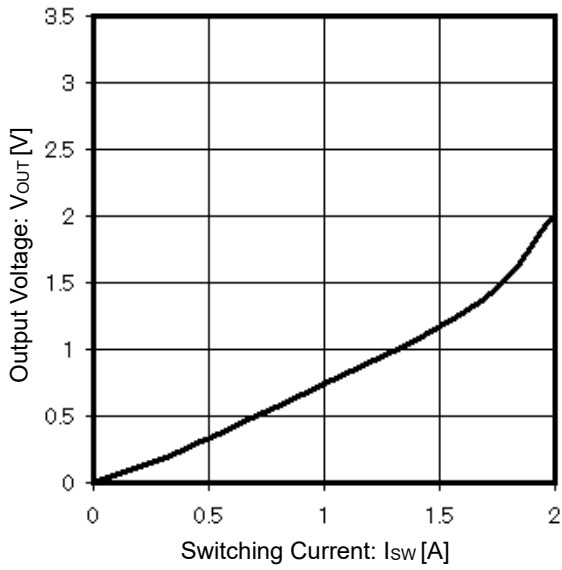

Figure 9. Output Voltage vs Switching Current

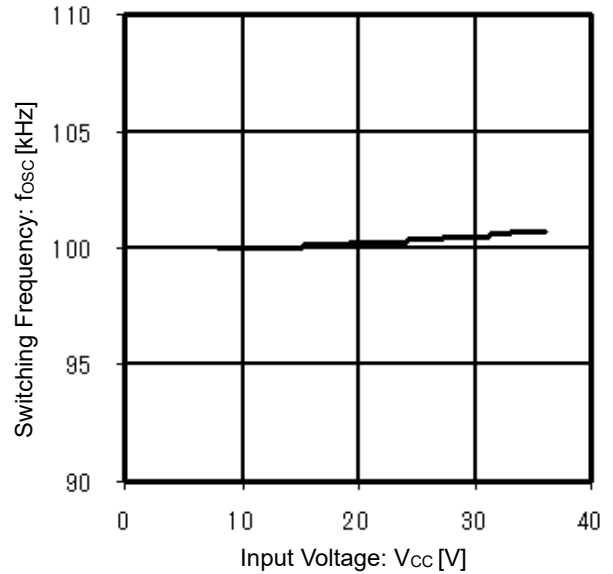

Figure 10. Switching Frequency vs Input Voltage

Typical Performance Curves- continued

(Unless otherwise specified: $T_a=25\text{deg}$, $V_{CC}=12\text{V}$, $V_{OUT}=5\text{V}$, $V_{STBY}=3\text{V}$)

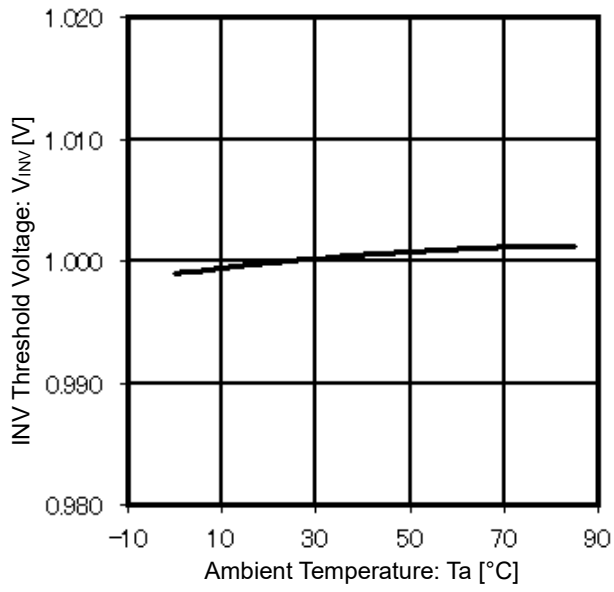

Figure 11. INV Threshold Voltage vs Ambient Temperature

Application Information

1. Block Function Explanation

- (1) VREF
This block generates a temperature independent regulated voltage from the VCC input.
- (2) OSC
This block generates a triangular waveform the frequency of which is set by internal resistors and capacitors. The 100kHz output of this block goes to the PWM comparator.
- (3) Error AMP
This block samples the output voltage from INV and compares it with the internal reference voltage. The output of this error amp goes into PWM COMP block. The reference voltage is 1.0V and accuracy is $\pm 2\%$.
- (4) PWM COMP
This block converts the Error AMP output to PWM pulses which go to the Driver block.
- (5) DRIVER
This push-pull FET driver which accepts PWM input pulses from PWM COMP block drives the internal Pch MOSFET.
- (6) STBY
ON/OFF operation of the IC is controlled via the STBY pin. The output is ON when STBY is High. The circuit current is under 5 μ A when STBY is Low.
- (7) Thermal Shutdown (TSD)
This circuit protects the IC against thermal runaway and damage due to excessive heat. A thermal sensor detects the junction temperature and switches the output OFF once the temperature exceeds a threshold value. This TSD has hysteresis and If the junction temperature goes down further than it, the output is turned ON again.
- (8) Over Current Protection (OCP)
The OCP circuit detects the voltage drop by measuring the current through the internal FET and turn ON the over current protection circuit. The OCP block is a self-recovery type (not latch).

2. Timing Chart

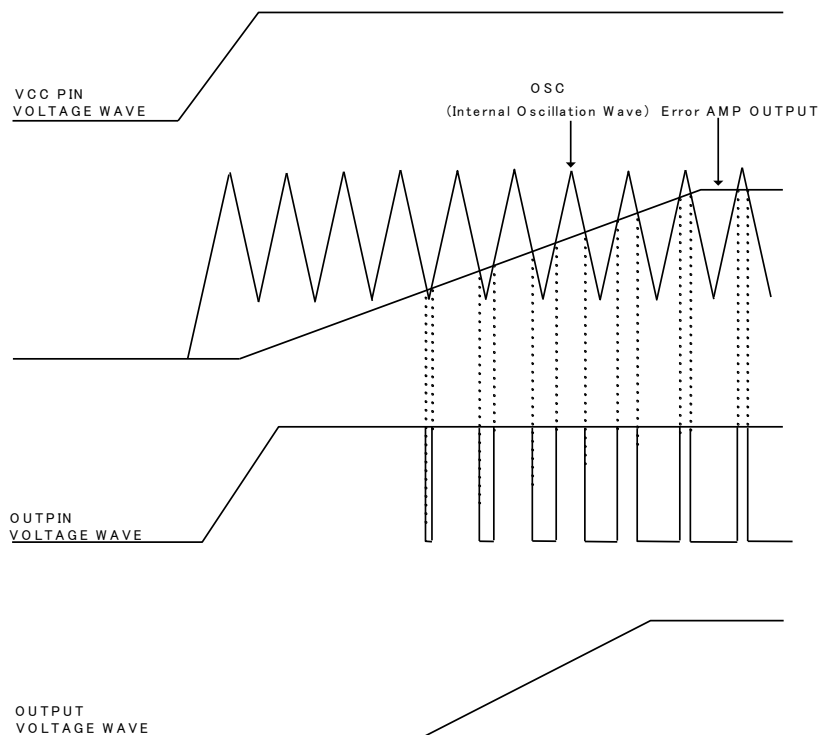

Figure 12. Timing Chart

3. Notes for PCB Layout

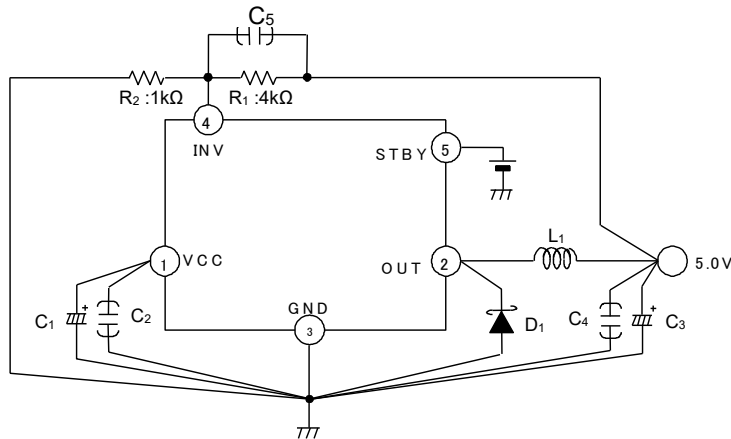

Figure 13. Layout

- (1) Place capacitors between VCC and Ground as close as possible to the IC to reduce ripple noise.
- (2) Place Schottky diode between OUT and Ground, and the Schottky diode as close as possible to the IC to reduce noise and maximize efficiency.
- (3) Connect resistors between INV and Ground, and the output capacitor filter at the same Ground potential in order to stabilize the output voltage.

4. Application Component Selection and Settings

(1) Inductor L_1

If the winding resistance of the choke coil is too high, the efficiency may deteriorate.

Even though the Over Current Protection operates when output current exceeds 1.6A minimum threshold, special attention should be given to the external inductor which could heat up due to the excessive current during over-load or short circuit.

Note that the current rating for the coil should be higher than $I_{OUT} (MAX) + \Delta I_L$. $I_{OUT} (MAX)$ is the maximum load current. If current through the coil exceeds the maximum rating, magnetic saturation, which accounts for efficiency deterioration or oscillation, may occur. Therefore, choose an inductor with current rating higher than the expected peak current.

$$\Delta I_L = \frac{(V_{CC} - V_{OUT})}{L_1} \times \frac{V_{OUT}}{V_{CC}} \times \frac{1}{f_{osc}}$$

Where:

L_1 is the inductor value

V_{CC} is the maximum input voltage

V_{OUT} is the output voltage

ΔI_L is the coil ripple current value

f_{osc} is the oscillation frequency

(2) **Schottky Barrier Diodes D₁**

A Schottky diode with extremely low forward voltage V_F should be used. Selection should be based on the following guidelines regarding maximum forward current, reverse voltage, and power dissipation:

- (a) The maximum current rating is higher than the combined maximum load current and coil ripple current (ΔI_L).
- (b) The reverse voltage rating is higher than the V_{IN} value.
- (c) Recommend using a diode with the smaller reverse current I_R as possible.
In the high temperature case, the reverse current is increasing and it may cause overdrive.
- (d) Power dissipation for the selected diode must be within the rated level.

The power dissipation of the diode is expressed by the following formula:

$$P_{di} = I_{OUT(MAX)} \times V_F \times (1 - V_{OUT} / V_{CC})$$

Where:

$I_{OUT(MAX)}$ is the maximum load current

V_F is the forward voltage

V_{OUT} is the output voltage

V_{CC} is the input voltage

(3) **Capacitor C₁, C₂, C₃, C₄, C₅**

Since large ripple currents flow through capacitors C_1 and C_3 , high frequency and low impedance electrolytic capacitors designed for switching power node must be used. Ceramic capacitor C_2 should be present to prevent noise from causing abnormal operation. If the ripple voltage of input and output is large, C_4 can be selected among ceramic, tantalum and OS capacitors with low ESR to reduce the ripple in addition to C_1 and C_3 . However if only low ESR capacitors are used, oscillation or unstable operation may occur. C_5 is the capacitor for phase compensation and is normally not used. If you need to improve the stability of the feedback network, connect C_5 between INV and OUTPUT or between INV and GND.

(4) **Feed Back Resistance R₁, R₂**

R_1 and R_2 are the feed back resistances for setting the output voltage. The output voltage is determined by the following expression:

$$V_{OUT} = (R_1 + R_2) V_{INV} / R_2$$

Where:

V_{INV} is INV Pin Threshold Voltage

The offset of output voltage is determined by both Feedback resistors and V_{IN} pin input current.

If feedback resistance is high, the setting of output voltage will change.

Recommended: Resistance between the INV pin and GND = 10 kΩ or less.

5. Recommended Circuit

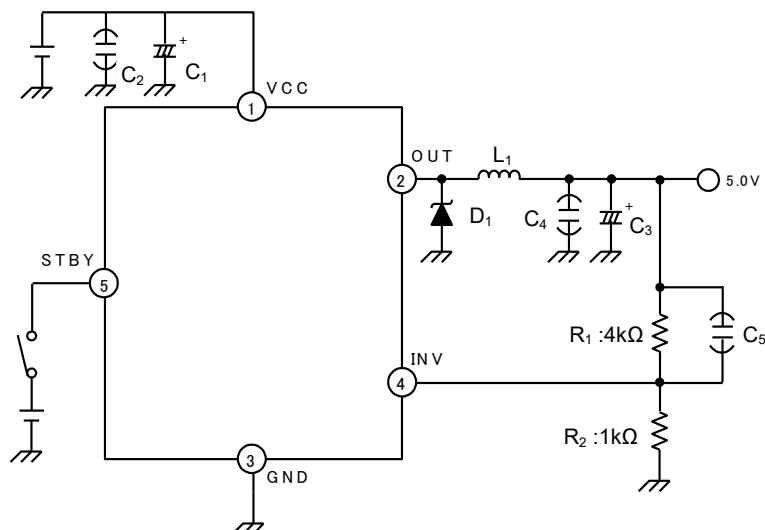

Figure 14. Recommended Circuit Output Voltage 5V: Application Circuit Example

<Recommended Components (Example)>

Inductor	L ₁ = 100μH	:CDRH127/LD (sumida)
Schottky Diode	D ₁	:RB050LA-40 (ROHM)
Capacitor	C ₁ = 100μF(50V)	:Al electric capacitor UHD1H101MPD (nichicon)
	C ₂ = OPEN	
	C ₃ = 220μF(25V)	:Al electric capacitor UHD1E221MPD (nichicon)
	C ₄ = OPEN	
	C ₅ = OPEN	

<Recommended Components example 2>

Inductor	L ₁ = 100μH	:CDRH127/LD (sumida)
Schottky Diode	D ₁	:RB050LA-40 (ROHM)
Capacitor	C ₁ = 220μF(25V)	:Al electric capacitor UVR1H221MPD (nichicon)
	C ₂ = 1.0μF(50V)	:Ceramic capacitor UMK105CBJ105MV-F (TAIYO YUDEN)
	C ₃ = 470μF(16V)	:Al electric capacitor UVR1E471MPD (nichicon)
	C ₄ = 150μF(20V)	:OS capacitor 20SVP150M (Panasonic)
	C ₅ = OPEN	

The product names listed in the bill of the materials are available ones at the time of creating this datasheet. In case some parts are no longer available in the future, select the equivalent products.

6. Test Circuit

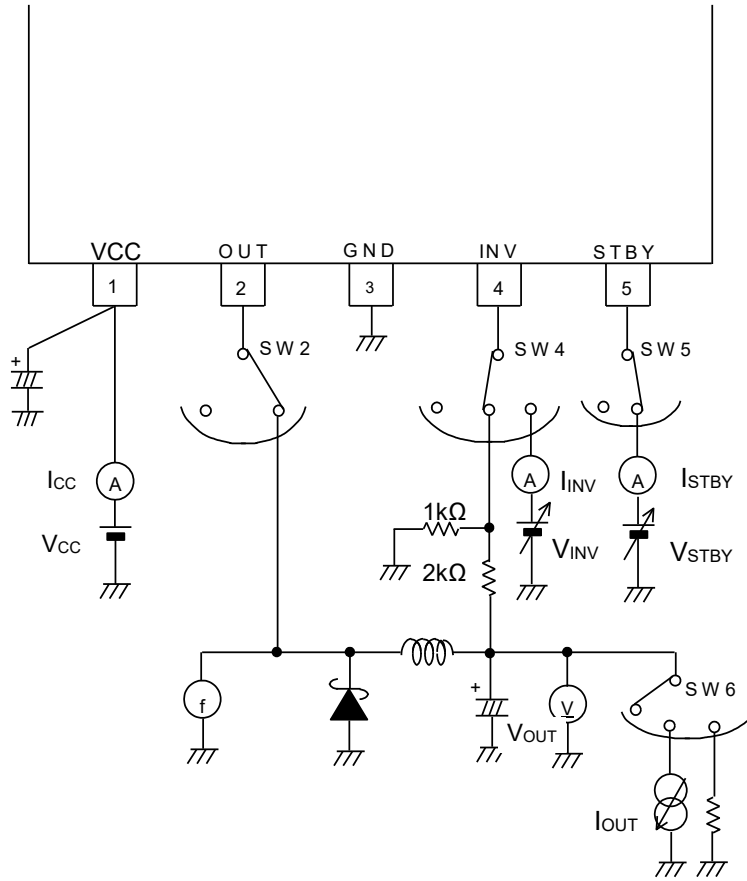

Figure 15. Input Output Measurement Circuit

Power Dissipation

TO252-5

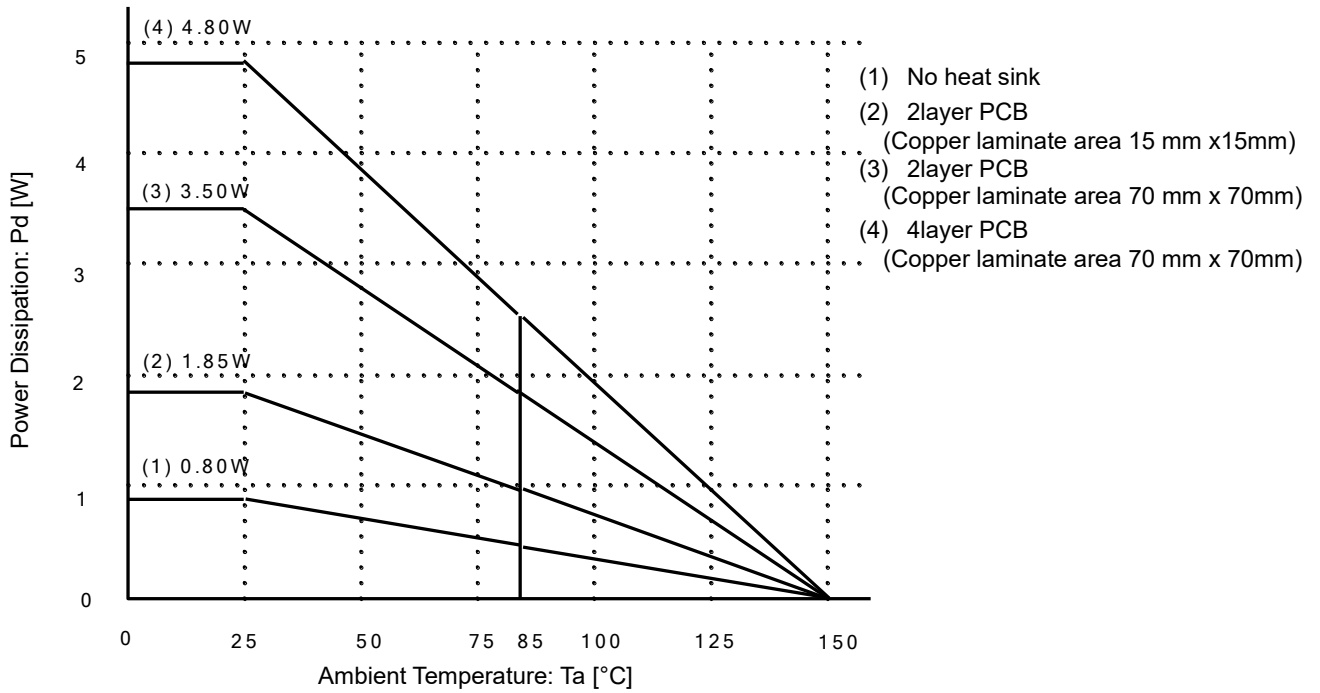

Figure 16. Power Dissipation

TO220

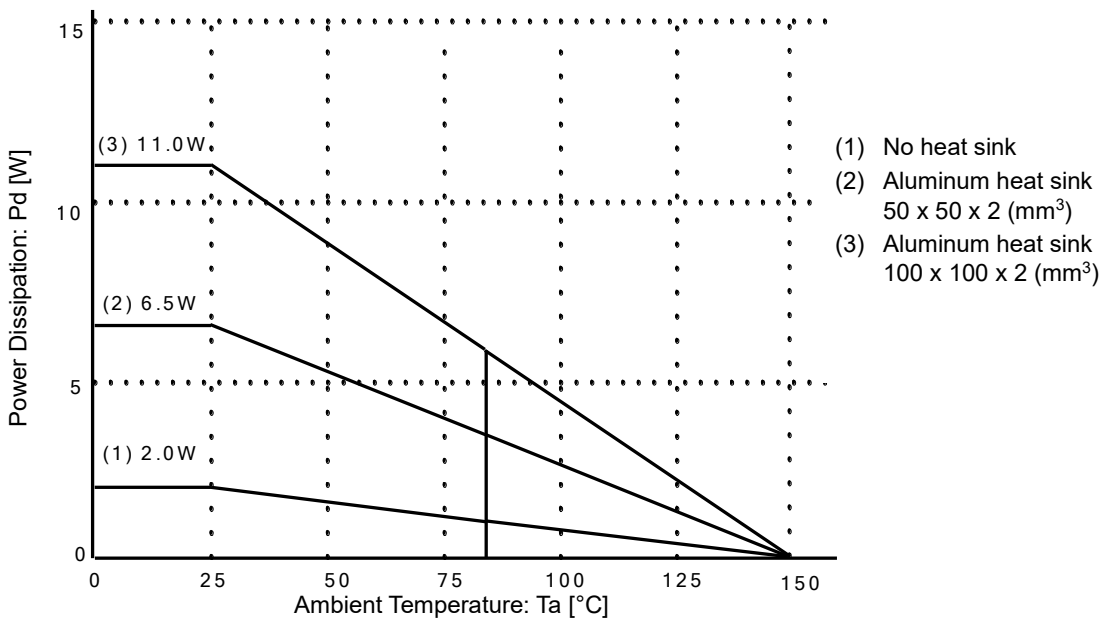

Figure 17. Power Dissipation

I/O Equivalent Circuit

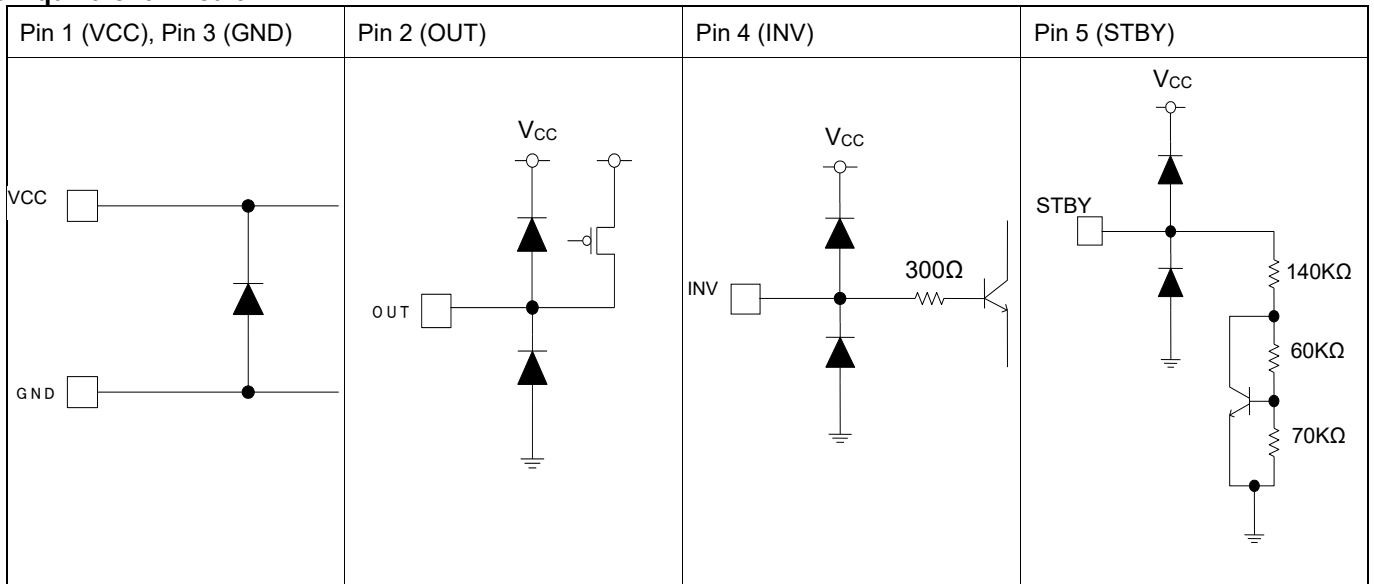

Figure 18. Input Output Equivalent Circuit

Operational Notes

1. Reverse Connection of Power Supply

Connecting the power supply in reverse polarity can damage the IC. Take precautions against reverse polarity when connecting the power supply, such as mounting an external diode between the power supply and the IC's power supply pins.

2. Power Supply Lines

Design the PCB layout pattern to provide low impedance supply lines. Separate the ground and supply lines of the digital and analog blocks to prevent noise in the ground and supply lines of the digital block from affecting the analog block. Furthermore, connect a capacitor to ground at all power supply pins. Consider the effect of temperature and aging on the capacitance value when using electrolytic capacitors.

3. Ground Voltage

Ensure that no pins are at a voltage below that of the ground pin at any time, even during transient condition.

4. Ground Wiring Pattern

When using both small-signal and large-current ground traces, the two ground traces should be routed separately but connected to a single ground at the reference point of the application board to avoid fluctuations in the small-signal ground caused by large currents. Also ensure that the ground traces of external components do not cause variations on the ground voltage. The ground lines must be as short and thick as possible to reduce line impedance.

5. Thermal Consideration

Should by any chance the power dissipation rating be exceeded the rise in temperature of the chip may result in deterioration of the properties of the chip. In case of exceeding this absolute maximum rating described in this datasheet, increase the board size and copper area to prevent exceeding the Pd rating.

6. Recommended Operating Conditions

These conditions represent a range within which the expected characteristics of the IC can be approximately obtained. The electrical characteristics are guaranteed under the conditions of each parameter.

7. Inrush Current

When power is first supplied to the IC, it is possible that the internal logic may be unstable and inrush current may flow instantaneously due to the internal powering sequence and delays, especially if the IC has more than one power supply. Therefore, give special consideration to power coupling capacitance, power wiring, width of ground wiring, and routing of connections.

8. Operation Under Strong Electromagnetic Field

Operating the IC in the presence of a strong electromagnetic field may cause the IC to malfunction.

9. Testing on Application Boards

When testing the IC on an application board, connecting a capacitor directly to a low-impedance output pin may subject the IC to stress. Always discharge capacitors completely after each process or step. The IC's power supply should always be turned off completely before connecting or removing it from the test setup during the inspection process. To prevent damage from static discharge, ground the IC during assembly and use similar precautions during transport and storage.

10. Inter-pin Short and Mounting Errors

Ensure that the direction and position are correct when mounting the IC on the PCB. Incorrect mounting may result in damaging the IC. Avoid nearby pins being shorted to each other especially to ground, power supply and output pin. Inter-pin shorts could be due to many reasons such as metal particles, water droplets (in very humid environment) and unintentional solder bridge deposited in between pins during assembly to name a few.

Operational Notes – continued

11. Unused Input Pins

Input pins of an IC are often connected to the gate of a MOS transistor. The gate has extremely high impedance and extremely low capacitance. If left unconnected, the electric field from the outside can easily charge it. The small charge acquired in this way is enough to produce a significant effect on the conduction through the transistor and cause unexpected operation of the IC. So unless otherwise specified, unused input pins should be connected to the power supply or ground line.

12. Regarding the Input Pin of the IC

This monolithic IC contains P+ isolation and P substrate layers between adjacent elements in order to keep them isolated. P-N junctions are formed at the intersection of the P layers with the N layers of other elements, creating a parasitic diode or transistor. For example (refer to figure below):

When $GND > Pin A$ and $GND > Pin B$, the P-N junction operates as a parasitic diode.
 When $GND > Pin B$, the P-N junction operates as a parasitic transistor.

Parasitic diodes inevitably occur in the structure of the IC. The operation of parasitic diodes can result in mutual interference among circuits, operational faults, or physical damage. Therefore, conditions that cause these diodes to operate, such as applying a voltage lower than the GND voltage to an input pin (and thus to the P substrate) should be avoided.

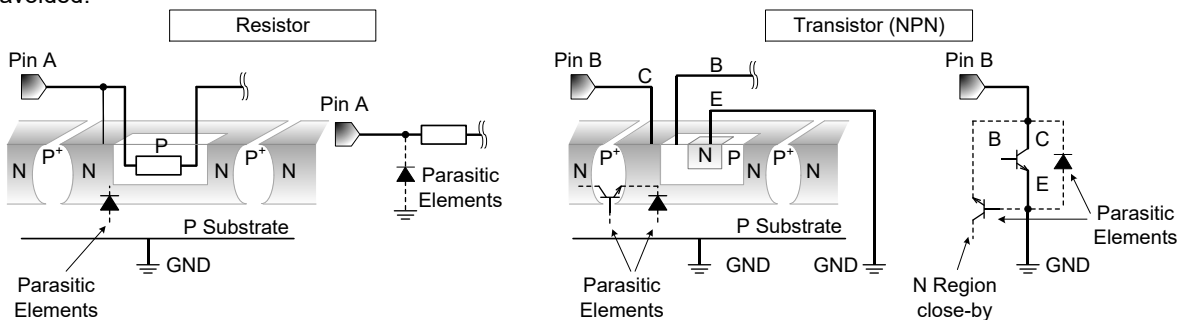

Figure 19. Example of monolithic IC structure

13. Thermal Shutdown Circuit(TSD)

This IC has a built-in thermal shutdown circuit that prevents heat damage to the IC. Normal operation should always be within the IC's power dissipation rating. If however the rating is exceeded for a continued period, the junction temperature (T_j) will rise which will activate the TSD circuit that will turn OFF all output pins. When the T_j falls below the TSD threshold, the circuits are automatically restored to normal operation.

Note that the TSD circuit operates in a situation that exceeds the absolute maximum ratings and therefore, under no circumstances, should the TSD circuit be used in a set design or for any purpose other than protecting the IC from heat damage.

14. Reverse Voltage

If reverse voltage is applied to VCC, there is a possibility that the internal circuits might be damaged.

For example, don't short VCC to GND while the external capacitors are charged.

Inserting a diode between VCC and the power terminal as reverse current prevention, or otherwise between the power terminal and other pins as a bypass diode are highly recommended.

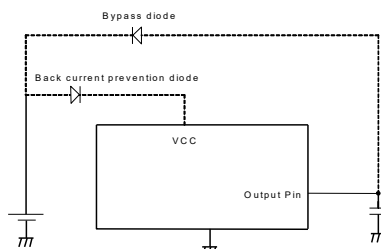

Figure 20

15. Application circuit

Although we can recommend the application circuits contained herein with a relatively high degree of confidence, we ask that you verify all characteristics and specifications of the circuit as well as performance under actual conditions. Please note that we cannot be held responsible for problems that may arise due to patent infringements or noncompliance with any and all applicable laws and regulations.

16. Operation

The IC will turn ON when the voltage at the STBY pin is greater than 2.0V and will become STBY state if under 0.3V. Therefore, do not keep the voltage between 0.3V and 2.0V. Malfunctions and/or physical damage may occur.

Ordering Information

B D 9 7 0 1 x x	-	x x x x
-----------------	---	---------

Part Number
9701=35V/1.5A

Package
FP : TO252-5
CP-V5 : TO220CP-V5
T/T-V5 : TO220FP-5(V5)

Packaging and forming specification
E2: Embossed tape and reel
None: Tray, Tube
V5 : Forming done

Lineup

Output Current	Switching Frequency	Package		Orderable Part Number	Part Number Marking
1.5A	100kHz (fixed)	TO252-5	Reel of 2000	BD9701FP-E2	BD9701
		TO220CP-V5	Reel of 500	BD9701CP-V5E2	BD9701CP
		TO220FP-5	Tube of 500	BD9701T	BD9701T
		TO220FP-5 (V5)	Tube of 500	BD9701T-V5	BD9701T

Marking Diagrams

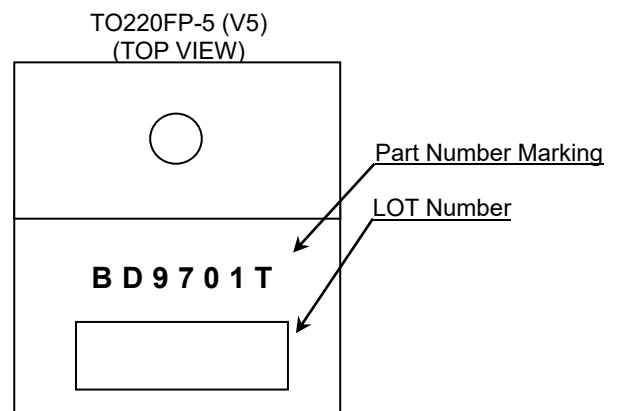
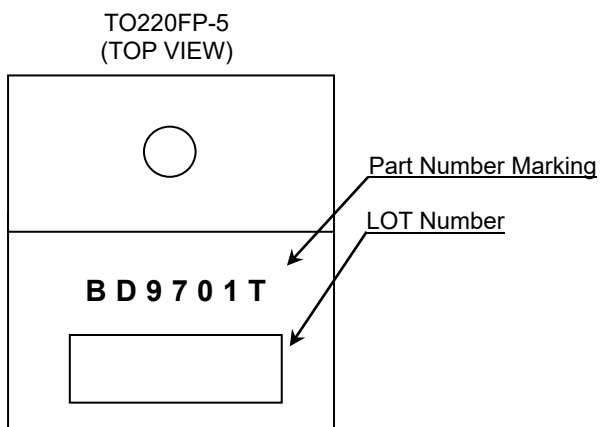
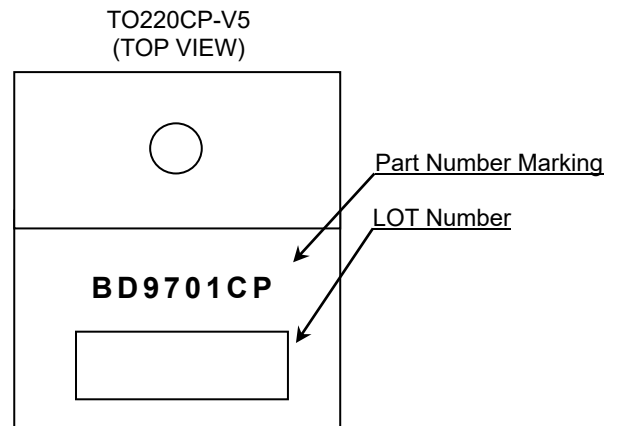
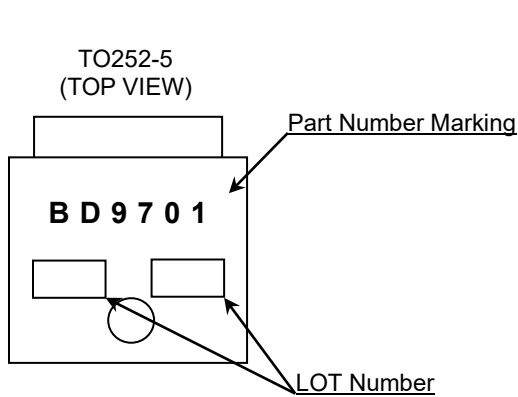

Physical Dimensions, Tape and Reel information

Package Name	TO252-5
--------------	---------

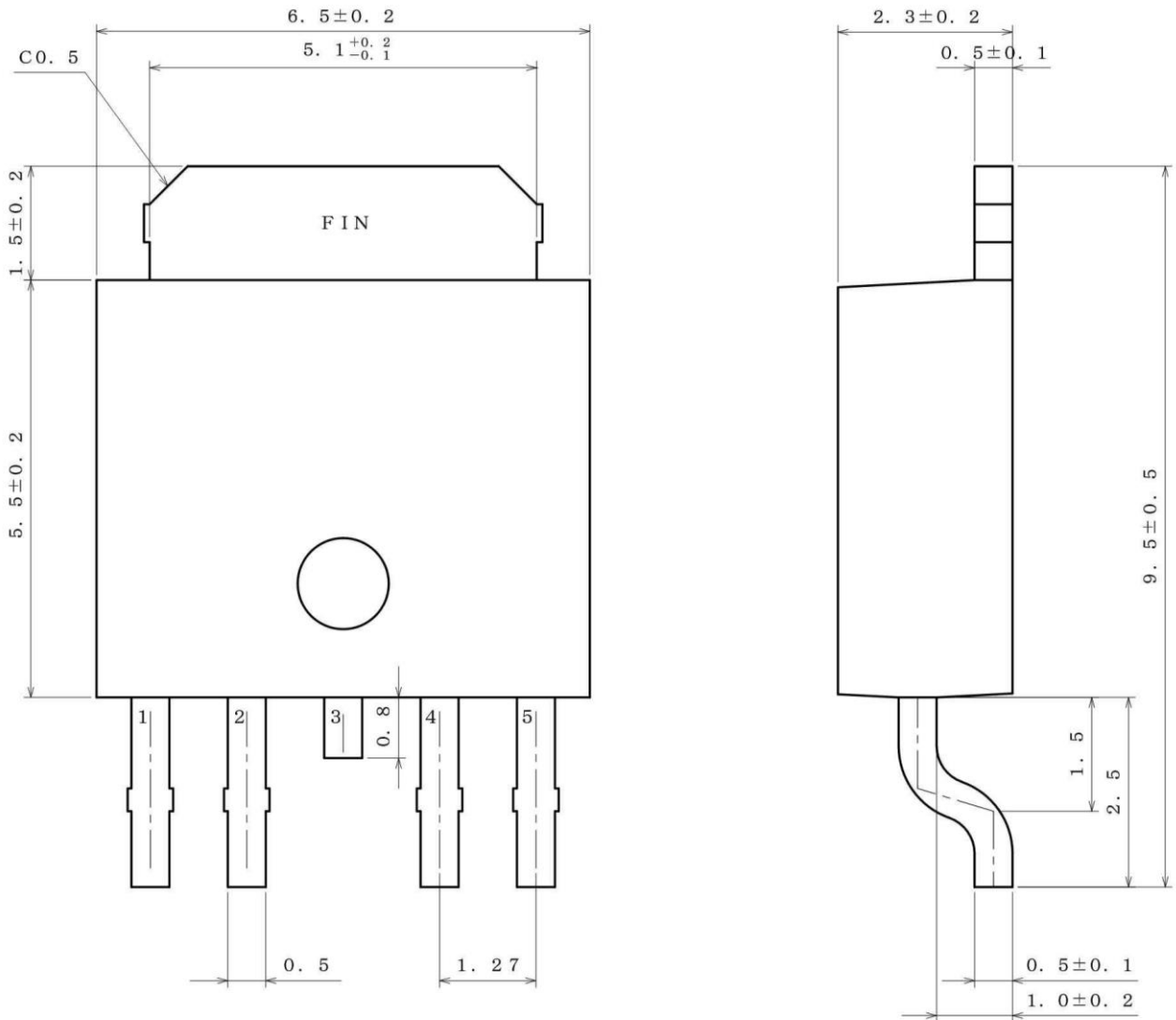

(UNIT : mm)
 PKG : TO252-5
 Drawing No. EX536-5001-1

<Tape and Reel information>

Tape	Embossed carrier tape
Quantity	2000pcs
Direction of feed	E2 (The direction is the 1pin of product is at the lower left when you hold reel on the left hand and you pull out the tape on the right hand)

* Order quantity needs to be multiple of the minimum quantity.

Physical Dimensions, Tape and Reel information - continued

Package Name	TO220CP-V5
--------------	------------

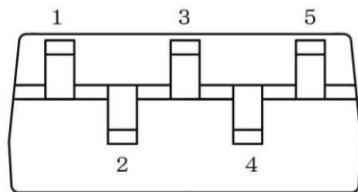
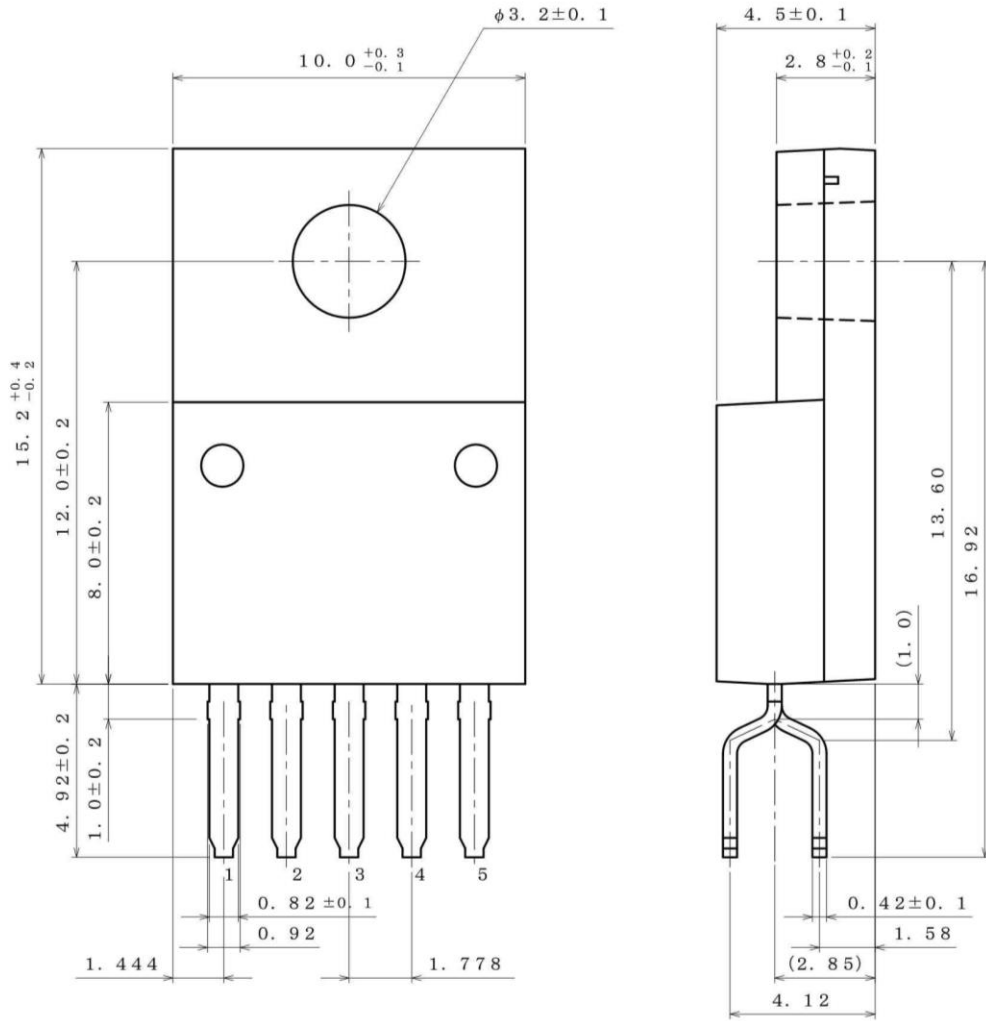

(UNIT : mm)
 PKG : TO220CP-V5
 Drawing No. EX545-5001

<Tape and Reel information>

Tape	Embossed carrier tape
Quantity	500pcs
Direction of feed	E2 (The direction is the 1pin of product is at the lower left when you hold reel on the left hand and you pull out the tape on the right hand)

*Order quantity needs to be multiple of the minimum quantity.

Physical Dimensions, Tape and Reel information - continued

Package Name	TO220FP-5
--------------	-----------

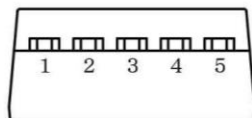
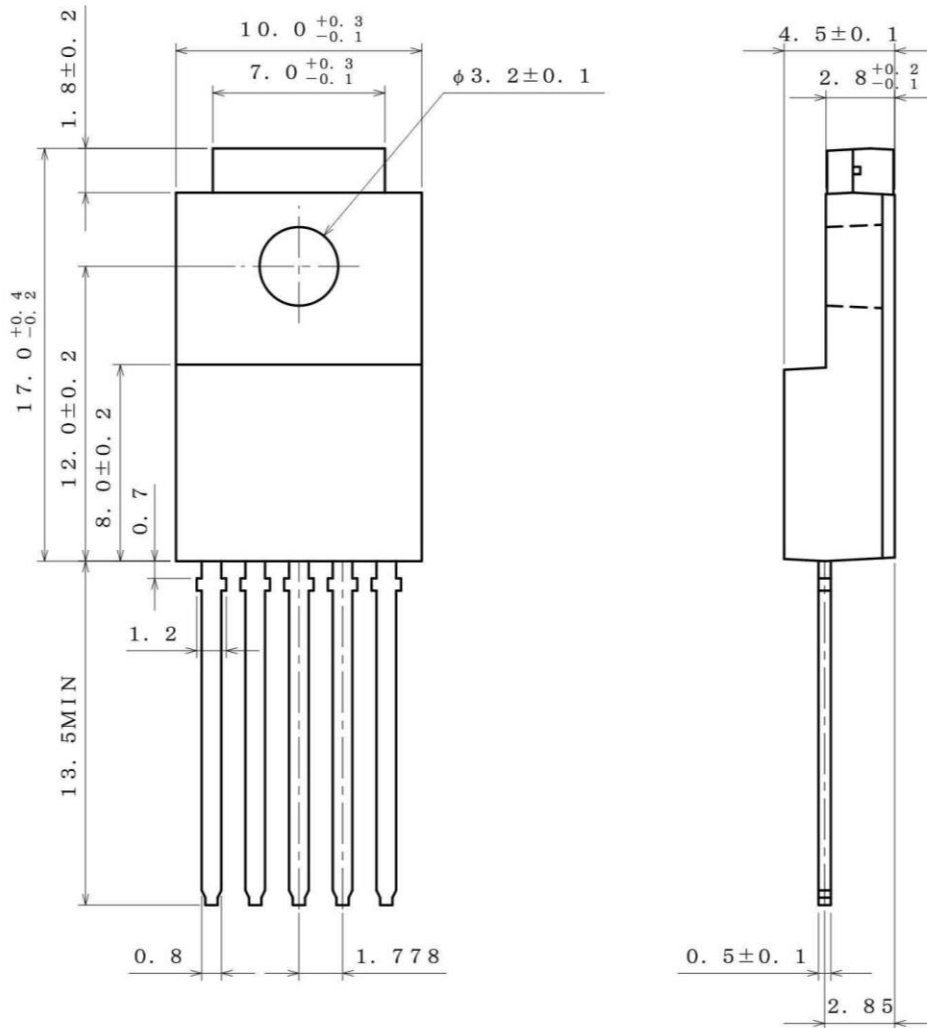

(UNIT : mm)

PKG : TO220FP-5

Drawing No. EX533-5002

<Tape and Reel information>

Container	Tube
Quantity	500pcs
Direction of feed	Direction of products is fixed in a container tube

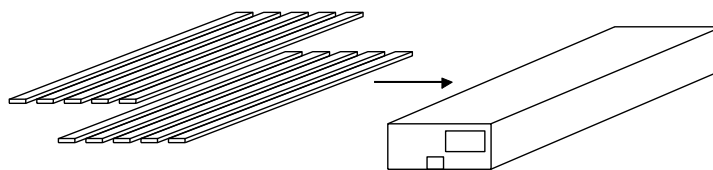

* Order quantity needs to be multiple of the minimum quantity.

Physical Dimensions, Tape and Reel information - continued

Package Name	TO220FP-5 V5
--------------	--------------

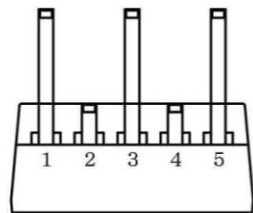
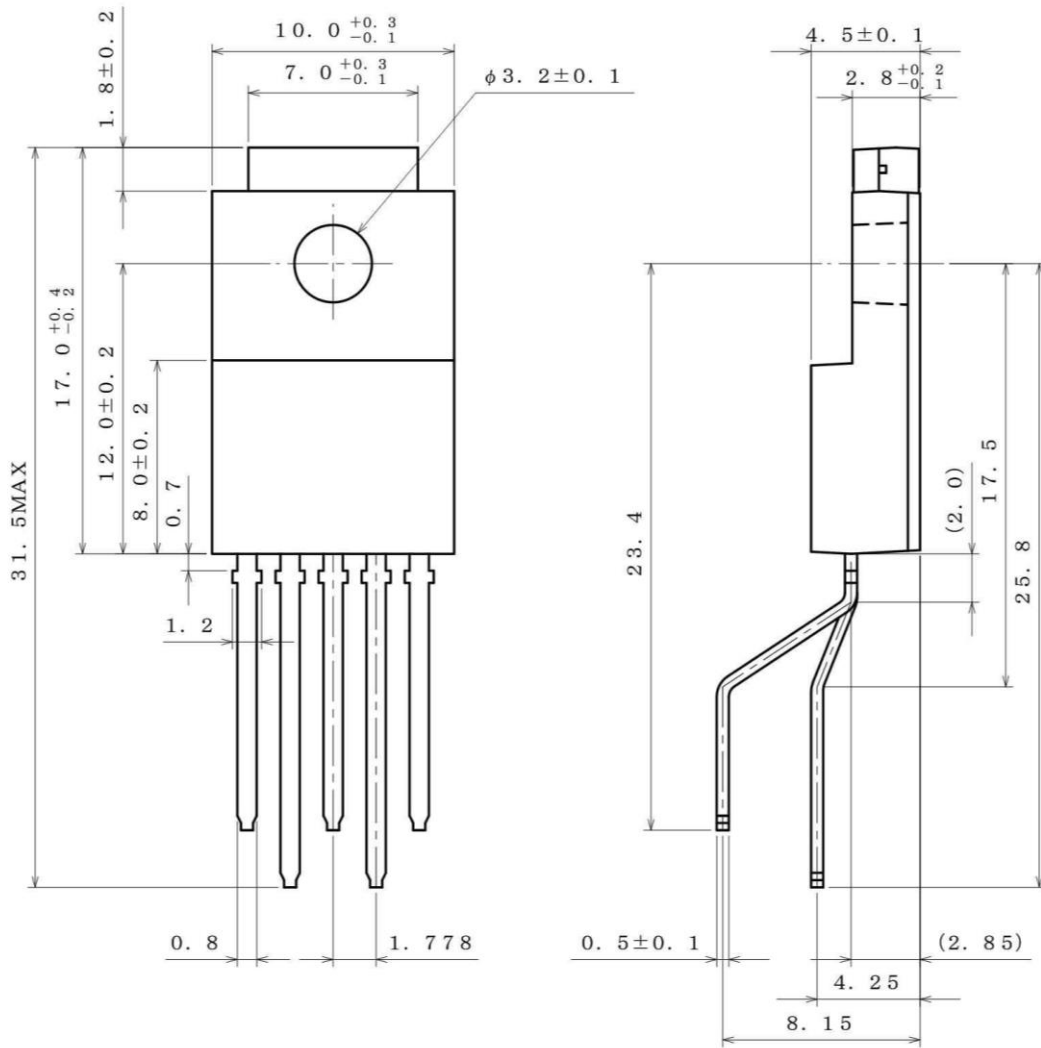

(UNIT : mm)
 PKG : TO220FP-5 V5
 Drawing No. EX534-5001

<Tape and Reel information>

Container	Tube
Quantity	500pcs
Direction of feed	Direction of products is fixed in a container tube

*Order quantity needs to be multiple of the minimum quantity.

Revision History

Date	Revision	Changes
04.Nov.2014	001	New Release
30.Sep.2021	002	Page 1 Fixed TO220CP-V5 package image Page 2 Fixed the pin description Page 3 Fixed the absolute maximum ratings parameter Page 4 Fixed the horizontal axis units of Figure 3 and Figure 6: A→mA Fixed the vertical axis: OSC Frequency -> Switching Frequency Page 7 Changed the descriptions in Application Information Page 8 Notes for PCB Layout: Fixed the description Application Component Selection and Settings: Fixed the description Page 9 Application Component Selection and Settings: Fixed the description Page 10 Recommend Circuit: Fixed part of the model names, manufacturer, and added a description Page 14, 15 Operational Notes: Fixed the descriptions

Notice

Precaution on using ROHM Products

- Our Products are designed and manufactured for application in ordinary electronic equipment (such as AV equipment, OA equipment, telecommunication equipment, home electronic appliances, amusement equipment, etc.). If you intend to use our Products in devices requiring extremely high reliability (such as medical equipment ^(Note 1), transport equipment, traffic equipment, aircraft/spacecraft, nuclear power controllers, fuel controllers, car equipment including car accessories, safety devices, etc.) and whose malfunction or failure may cause loss of human life, bodily injury or serious damage to property ("Specific Applications"), please consult with the ROHM sales representative in advance. Unless otherwise agreed in writing by ROHM in advance, ROHM shall not be in any way responsible or liable for any damages, expenses or losses incurred by you or third parties arising from the use of any ROHM's Products for Specific Applications.

(Note1) Medical Equipment Classification of the Specific Applications

JAPAN	USA	EU	CHINA
CLASS III	CLASS III	CLASS II b	CLASS III
CLASS IV		CLASS III	

- ROHM designs and manufactures its Products subject to strict quality control system. However, semiconductor products can fail or malfunction at a certain rate. Please be sure to implement, at your own responsibilities, adequate safety measures including but not limited to fail-safe design against the physical injury, damage to any property, which a failure or malfunction of our Products may cause. The following are examples of safety measures:
 - Installation of protection circuits or other protective devices to improve system safety
 - Installation of redundant circuits to reduce the impact of single or multiple circuit failure
- Our Products are designed and manufactured for use under standard conditions and not under any special or extraordinary environments or conditions, as exemplified below. Accordingly, ROHM shall not be in any way responsible or liable for any damages, expenses or losses arising from the use of any ROHM's Products under any special or extraordinary environments or conditions. If you intend to use our Products under any special or extraordinary environments or conditions (as exemplified below), your independent verification and confirmation of product performance, reliability, etc. prior to use, must be necessary:
 - Use of our Products in any types of liquid, including water, oils, chemicals, and organic solvents
 - Use of our Products outdoors or in places where the Products are exposed to direct sunlight or dust
 - Use of our Products in places where the Products are exposed to sea wind or corrosive gases, including Cl₂, H₂S, NH₃, SO₂, and NO₂
 - Use of our Products in places where the Products are exposed to static electricity or electromagnetic waves
 - Use of our Products in proximity to heat-producing components, plastic cords, or other flammable items
 - Sealing or coating our Products with resin or other coating materials
 - Use of our Products without cleaning residue of flux (Exclude cases where no-clean type fluxes is used. However, recommend sufficiently about the residue.) ; or Washing our Products by using water or water-soluble cleaning agents for cleaning residue after soldering
 - Use of the Products in places subject to dew condensation
- The Products are not subject to radiation-proof design.
- Please verify and confirm characteristics of the final or mounted products in using the Products.
- In particular, if a transient load (a large amount of load applied in a short period of time, such as pulse, is applied, confirmation of performance characteristics after on-board mounting is strongly recommended. Avoid applying power exceeding normal rated power; exceeding the power rating under steady-state loading condition may negatively affect product performance and reliability.
- De-rate Power Dissipation depending on ambient temperature. When used in sealed area, confirm that it is the use in the range that does not exceed the maximum junction temperature.
- Confirm that operation temperature is within the specified range described in the product specification.
- ROHM shall not be in any way responsible or liable for failure induced under deviant condition from what is defined in this document.

Precaution for Mounting / Circuit board design

- When a highly active halogenous (chlorine, bromine, etc.) flux is used, the residue of flux may negatively affect product performance and reliability.
- In principle, the reflow soldering method must be used on a surface-mount products, the flow soldering method must be used on a through hole mount products. If the flow soldering method is preferred on a surface-mount products, please consult with the ROHM representative in advance.

For details, please refer to ROHM Mounting specification

Precautions Regarding Application Examples and External Circuits

1. If change is made to the constant of an external circuit, please allow a sufficient margin considering variations of the characteristics of the Products and external components, including transient characteristics, as well as static characteristics.
2. You agree that application notes, reference designs, and associated data and information contained in this document are presented only as guidance for Products use. Therefore, in case you use such information, you are solely responsible for it and you must exercise your own independent verification and judgment in the use of such information contained in this document. ROHM shall not be in any way responsible or liable for any damages, expenses or losses incurred by you or third parties arising from the use of such information.

Precaution for Electrostatic

This Product is electrostatic sensitive product, which may be damaged due to electrostatic discharge. Please take proper caution in your manufacturing process and storage so that voltage exceeding the Products maximum rating will not be applied to Products. Please take special care under dry condition (e.g. Grounding of human body / equipment / solder iron, isolation from charged objects, setting of ionizer, friction prevention and temperature / humidity control).

Precaution for Storage / Transportation

1. Product performance and soldered connections may deteriorate if the Products are stored in the places where:
 - [a] the Products are exposed to sea winds or corrosive gases, including Cl₂, H₂S, NH₃, SO₂, and NO₂
 - [b] the temperature or humidity exceeds those recommended by ROHM
 - [c] the Products are exposed to direct sunshine or condensation
 - [d] the Products are exposed to high Electrostatic
2. Even under ROHM recommended storage condition, solderability of products out of recommended storage time period may be degraded. It is strongly recommended to confirm solderability before using Products of which storage time is exceeding the recommended storage time period.
3. Store / transport cartons in the correct direction, which is indicated on a carton with a symbol. Otherwise bent leads may occur due to excessive stress applied when dropping of a carton.
4. Use Products within the specified time after opening a humidity barrier bag. Baking is required before using Products of which storage time is exceeding the recommended storage time period.

Precaution for Product Label

A two-dimensional barcode printed on ROHM Products label is for ROHM's internal use only.

Precaution for Disposition

When disposing Products please dispose them properly using an authorized industry waste company.

Precaution for Foreign Exchange and Foreign Trade act

Since concerned goods might be fallen under listed items of export control prescribed by Foreign exchange and Foreign trade act, please consult with ROHM in case of export.

Precaution Regarding Intellectual Property Rights

1. All information and data including but not limited to application example contained in this document is for reference only. ROHM does not warrant that foregoing information or data will not infringe any intellectual property rights or any other rights of any third party regarding such information or data.
2. ROHM shall not have any obligations where the claims, actions or demands arising from the combination of the Products with other articles such as components, circuits, systems or external equipment (including software).
3. No license, expressly or implied, is granted hereby under any intellectual property rights or other rights of ROHM or any third parties with respect to the Products or the information contained in this document. Provided, however, that ROHM will not assert its intellectual property rights or other rights against you or your customers to the extent necessary to manufacture or sell products containing the Products, subject to the terms and conditions herein.

Other Precaution

1. This document may not be reprinted or reproduced, in whole or in part, without prior written consent of ROHM.
2. The Products may not be disassembled, converted, modified, reproduced or otherwise changed without prior written consent of ROHM.
3. In no event shall you use in any way whatsoever the Products and the related technical information contained in the Products or this document for any military purposes, including but not limited to, the development of mass-destruction weapons.
4. The proper names of companies or products described in this document are trademarks or registered trademarks of ROHM, its affiliated companies or third parties.

General Precaution

1. Before you use our Products, you are requested to carefully read this document and fully understand its contents. ROHM shall not be in any way responsible or liable for failure, malfunction or accident arising from the use of any ROHM's Products against warning, caution or note contained in this document.
2. All information contained in this document is current as of the issuing date and subject to change without any prior notice. Before purchasing or using ROHM's Products, please confirm the latest information with a ROHM sales representative.
3. The information contained in this document is provided on an "as is" basis and ROHM does not warrant that all information contained in this document is accurate and/or error-free. ROHM shall not be in any way responsible or liable for any damages, expenses or losses incurred by you or third parties resulting from inaccuracy or errors of or concerning such information.