

ISL55100A

Quad 18V Pin Electronics Driver/Window Comparator

FN7486
Rev 3.00
December 4, 2014

The ISL55100A is a Quad pin driver and window comparator fabricated in a wide voltage CMOS process. It is designed specifically for Test During Burn In (TDBI) applications, where cost, functional density and power are all at a premium.

This IC incorporates four channels of programmable drivers and window comparators into a small 72 Ld QFN package. Each channel has independent driver levels, data and high impedance control. Each receiver has dual comparators, which provide high and low threshold levels.

The ISL55100A uses differential mode digital inputs and can therefore mate directly with LVDS or CML outputs. Single-ended logic families are handled by connecting one of the digital input pins to an appropriate threshold voltage (e.g., 1.4V for TTL compatibility). The comparator outputs are single-ended and the output levels are user defined to mate directly with any digital technology.

The 18V driver output and receiver input ranges allow this device to interface directly with TTL, ECL, CMOS (3V, 5V and 7V), LVCMOS and custom level circuitry, as well as the high voltage (super voltage) level required for many special test modes for Flash Devices.

Features

- Low driver output resistance
- R_{OUT} maximum: ISL55100A 7.0Ω
- 18V I/O range
- 50MHz operation
- 4-channel driver/receiver pairs with per pin flexibility
- Dual level - per pin - input thresholds
- Differential or single-ended digital inputs
- User defined comparator output levels
- Low channel-to-channel timing skew
- Small footprint (72 Ld QFN)
- Pb-free (RoHS compliant)

Applications

- Burn in ATE
- Wafer level flash memory test
- LCD panel test
- Low cost ATE
- Instrumentation
- Emulation
- Device programmers

Functional Block Diagram

QUAD - WIDE RANGE, LOW ROUT, TRI-STATEABLE - DRIVERS

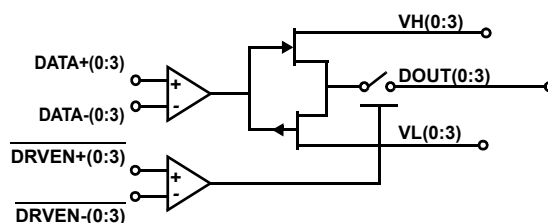

QUAD - DUAL LEVEL COMPARATOR - RECEIVERS

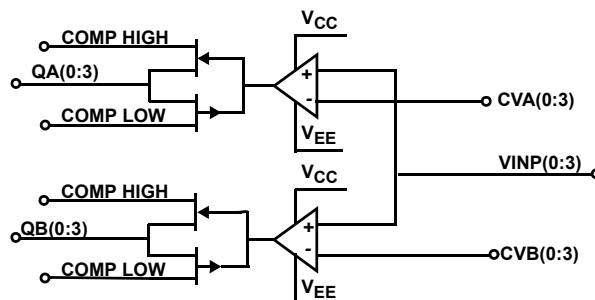

Ordering Information

PART NUMBER (Notes 1, 2, 3)	PART MARKING	TEMP. RANGE (°C)	PACKAGE (RoHS Compliant)	PKG. DWG. #
ISL55100AIRZ	ISL55100 AIRZ	-40 to +85	72 Ld QFN	L72.10x10
ISL55100AEVAL3Z	Evaluation Board			

NOTES:

1. Add "-T" suffix for tape and reel. Please refer to [TB347](#) for details on reel specifications
2. These Intersil Pb-free plastic packaged products employ special Pb-free material sets, molding compounds/die attach materials, and 100% matte tin plate plus anneal (e3 termination finish, which is RoHS compliant and compatible with both SnPb and Pb-free soldering operations). Intersil Pb-free products are MSL classified at Pb-free peak reflow temperatures that meet or exceed the Pb-free requirements of IPC/JEDEC J STD-020.
3. For Moisture Sensitivity Level (MSL), please see product information page for [ISL55100A](#) For more information on MSL, please see tech brief [TB363](#).

Pin Configuration

ISL55100A
(72 LD QFN)
TOP VIEW

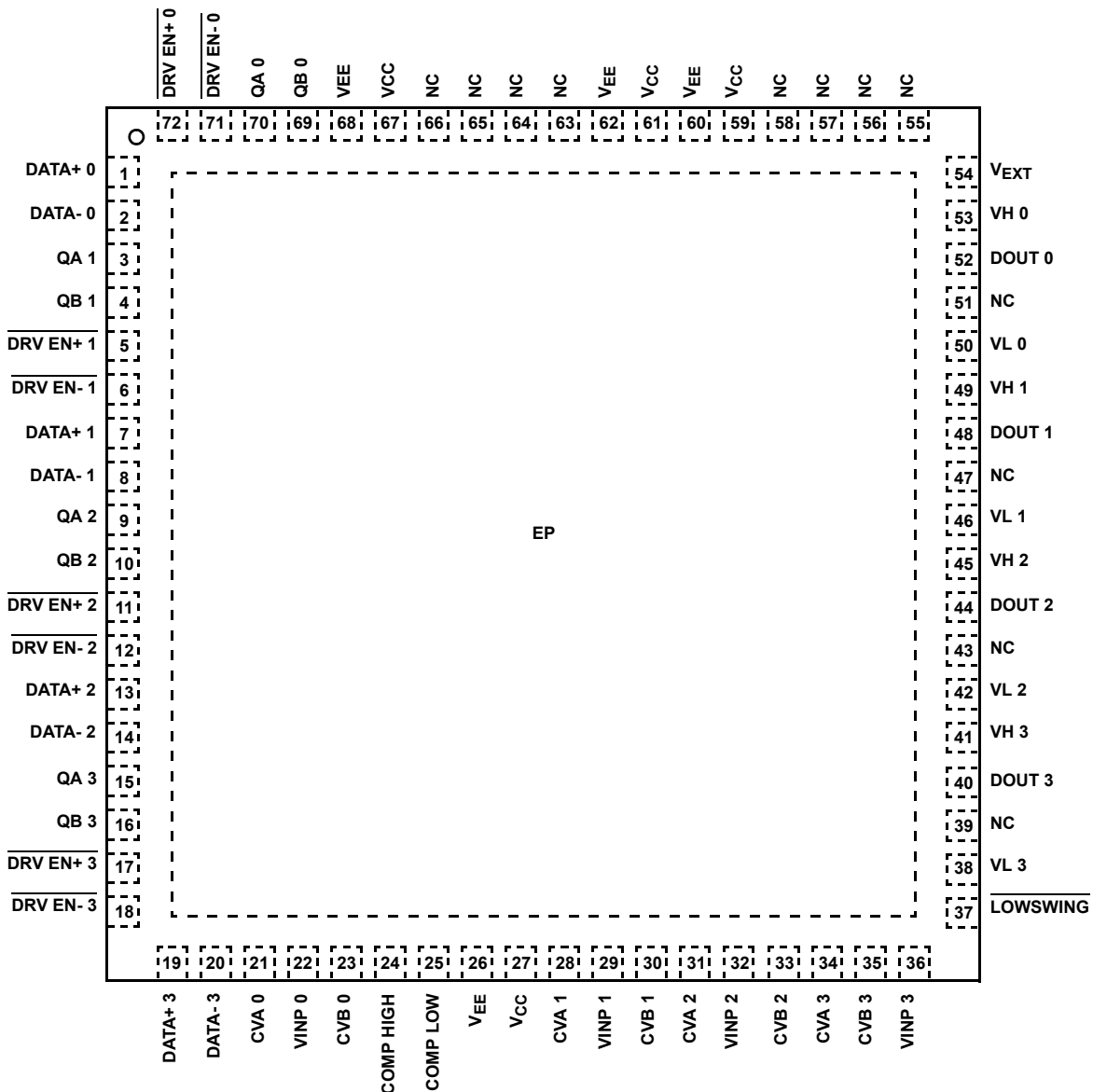

Pin Descriptions

PIN NAME	FUNCTION
DATA+(0:3)	Positive differential digital input that determines the driver output state when it is enabled.
DATA-(0:3)	Negative differential digital input that determines the driver output state when it is enabled.
$\overline{\text{DRV EN}}+(0:3)$	Positive differential digital input that enables or disables the corresponding driver.
$\overline{\text{DRV EN}}-(0:3)$	Negative differential digital input that enables or disables the corresponding driver.
QA (0:3)	Comparator digital outputs. QA(X) is high when VINP(X) exceeds CVA(X).
QB (0:3)	Comparator digital outputs. QB(X) is high when VINP(X) exceeds CVB(X).
DOUT (0:3)	Driver outputs.
VINP (0:3)	Comparator inputs.
VH (0:3)	Unbuffered analog inputs that set each individual driver's "high" voltage level.
VL (0:3)	Unbuffered analog inputs that set each individual driver's "low" voltage level. VL must be a lower voltage than VH.
NC	No internal connection.
CVA (0:3)	Analog inputs that set the threshold for the corresponding Channel's A comparators.
CVB (0:3)	Analog inputs that set the threshold for the corresponding Channel's B comparators.
COMP HI	Supply voltage, unbuffered input that sets the high output level of all comparators. Must be greater than COMP LO.
COMP LO	Supply voltage, unbuffered input that sets the low output level of all comparators. Must be less than COMP HI.
V _{CC}	Positive power supply (5% tolerance).
V _{EE}	Negative power supply (5% tolerance). This is also the potential of the exposed thermal pad on the package bottom.
V _{EXT}	External 5.5VDC power supply (5.5VDC to 6.0VDC as referenced to V_{EE} , NOT GND. Recommended V _{EXT} = 5.5V) for internal logic. Connect pin to V _{EE} when not using an external supply.
$\overline{\text{LOWSWING}}$	Input that selects driver output configurations optimized to yield minimum overshoots for low level swings (VH < V _{EE} +5V), or optimized for large output swings. Connect $\overline{\text{LOWSWING}}$ to V _{EE} to select low swing circuitry, or connect it to V _{CC} to select high swing circuitry.
EP	QFN package exposed thermal pad; connect to V _{EE} .

Truth Tables

DRIVERS		
INPUTS		OUTPUT
DATA	$\overline{\text{DRV EN}}$	DOUT
X	+ > -	Hi - Z
+ > -	+ < -	VH
+ < -	+ < -	VL

X = DON'T CARE

RECEIVERS			
INPUT		OUTPUTS	
VINP		QA	QB
<CVA	<CVB	0	0
<CVA	>CVB	0	1
>CVA	<CVB	1	0
>CVA	>CVB	1	1

Absolute Maximum Ratings

V_{CC} to V_{EE}	-0.5V to 19V
V_{EXT} to V_{EE}	-0.5V to 7V
Input Voltages	
DATA, DRV EN, CVX, VH, VL, VINP, COMPX, LOWSWING	
.....	($V_{EE} - 0.5V$) to ($V_{CC} + 0.5V$)
Output Voltages	
DOUT	($V_{EE} - 0.5V$) to ($V_H + 0.5V$)
QX	(COMP LOW - 0.5V) to (COMP HIGH + 0.5V)

Thermal Information

Thermal Resistance (Typical, Notes 4, 5)	θ_{JA} ($^{\circ}C/W$)	θ_{JC} ($^{\circ}C/W$)
72 Ld QFN Package	23	2.0
Maximum Junction Temperature (Plastic Package)	+150 $^{\circ}C$	
Maximum Storage Temperature Range	-65 $^{\circ}C$ to +150 $^{\circ}C$	
Pb-Free Reflow Profile	see TB493	

CAUTION: Do not operate at or near the maximum ratings listed for extended periods of time. Exposure to such conditions may adversely impact product reliability and result in failures not covered by warranty.

NOTES:

- θ_{JA} is measured in free air with the component mounted on a high effective thermal conductivity test board with "direct attach" features. See Tech Brief [TB379](#).
- For θ_{JC} , the "case temp" location is the center of the exposed metal pad on the package underside.
- Device temperature is closely tied to data-rates, driver loads and overall pin activity. Review "[Power Dissipation Considerations](#)" on page 9 for more information.

Recommended Operating Conditions

PARAMETER	SYMBOL	MIN (Note 13)	TYP	MAX (Note 13)	UNITS
Device Power-($V_{EXT} = V_{EE}$) V_{EXT} Not Used	$V_{CC} - V_{EE}$	12 (Note 10)	15	18	V
Device Power-($V_{EXT} = V_{EE} + 5.5V$)	$V_{CC} - V_{EE}$	9 (Note 10)	15	18	V
V_{EXT} Optional External Logic Power	$V_{EXT} - V_{EE}$	5.5 (Note 10)	5.75	6.0	V
Driver Output High Rail	V_H	$V_{EE} + 1$	-	$V_{CC} - 0.5$	V
Driver Output Low Rail	V_L	$V_{EE} + 0.5$	-	$V_{EE} + 6$	V
Comparator Output High Rail	COMP-High	$V_{EE} + 1$	-	$V_{CC} - 0.5$	V
Comparator Output Low Rail	COMP-Low	$V_{EE} + 0.5$	-	$V_{EE} + 6$	V
Ambient Temperature	T_A	-40	-	+85	$^{\circ}C$
Junction Temperature	T_J	-	-	+150	$^{\circ}C$

Electrical Specifications

Test Conditions: $V_{CC} = 1.2V$, $V_{EE} = -3V$, $V_H = 6V$, $V_L = 0V$, Comp-High = 5V, Comp-Low = 0V, $V_{5V} = V_{EE}$ and LOWSWING = V_{CC} .

PARAMETER	SYMBOL	TEST CONDITIONS	MIN	TYP	MAX	UNITS
DRIVER DC CHARACTERISTICS						
ISL55100A Output Resistance	R_{OUTD}	$I_O = \pm 200mA$, data not toggling	3	4.5	7.0	Ω
ISL55100A DC Output Current	I_{OUTD}	Per Individual driver	± 200	-	-	mA
ISL55100A AC Output Current (Note 6)	I_{OUTDAC}	Per Individual driver	-	1.0	-	A
ISL55100A Minimum Output Swing	V_{OMIN}	$V_H = 200mV$, $V_L = 0V$	185	-	-	mV
Disabled HIZ Leakage Current	HIZ	$V_{OUT} = V_{CC}$ with $V_H = V_L + V_{EE}$ or $V_{OUT} = V_{EE}$ with $V_H = V_L = V_{CC}$	-1	0	1	μA
DRIVER TIMING CHARACTERISTICS						
Data \pm to DOUT Propagation Delay	t_{pD}	Lowswing Disabled (Note 9)	8	12	16	ns
		Lowswing Enabled (Note 9)	9	13	17	ns
Driver Timing Skew, All Edges (Note 7)			-	<1	-	ns
Disable (HIZ) Time	t_{DIS}	DVREN \pm Transition from Enable to Disable	16	18	26	ns

Electrical Specifications Test Conditions: $V_{CC} = 12V$, $V_{EE} = -3V$, $V_H = 6V$, $V_L = 0V$, Comp-High = 5V, Comp-Low = 0V, $V_{5V} = V_{EE}$ and $LOWSWING = V_{CC}$. (Continued)

PARAMETER	SYMBOL	TEST CONDITIONS	MIN	TYP	MAX	UNITS	
Enable Time	t_{EN}	DVREN± Transition from Disable to Enable: Lowswing Disabled (Note 9)	13	15	23	ns	
		DVREN± Transition from Disable to Enable: Lowswing Enabled (Note 9)	13	18	23	ns	
ISL55100A Rise/Fall Times (Note 7)	t_R, t_F	100pF Load	$\Delta V = 0.4V$ (20% to 80%)	-	2.5	-	ns
			$\Delta V = 1V$ (20% to 80%)	-	2.5	-	ns
			$\Delta V = 5V$ (10% to 90%)	-	2.5	-	ns
			$\Delta V = 10V$ (10% to 90%)	-	2.5	-	ns
			$\Delta V = 14V$ (10% to 90%)	-	2.5	-	ns
ISL55100A Rise/Fall Times (Note 7)	t_R, t_F	1000pF Load	$\Delta V = 1V$ (20% to 80%)	-	8.0	-	ns
			$\Delta V = 5V$ (10% to 90%)	-	10.0	-	ns
			$\Delta V = 10V$ (10% to 90%)	-	14.0	-	ns
ISL55100A Maximum Toggle Frequency	FMAXD	No Load, 50% Symmetry	50	65	-	MHz	
ISL55100A Min Driver Pulse Width	t_{WIDD}	Standard Load, 1k/100pF (Note 8)	-	7.7	-	ns	
ISL55100A Overshoot Lowswing Mode (Note 7)	OS	Lowswing Enabled, ($V_H - V_L < 2V$)	-	20mV+ 10% of output swing	-	%+V	
RECEIVER DC CHARACTERISTICS							
Input Offset Voltage	V_{OS}	$CVA = CVB = 1.5V$	-50	-	50	mV	
Input Bias Current	I_{BIAS}	$V_{INP} - CV_{(A/B)} = \pm 5V$	-	10	30	nA	
Output Resistance	R_{OUTR}		18	25	35	Ω	
RECEIVER TIMING CHARACTERISTICS							
Propagation Delay	t_{PP}		7	12	18	ns	
Maximum Operating Frequency	F_{MAXR}	Under No Load, PWOUT Symmetry 50%	50	65	-	MHz	
Minimum Pulse Width	t_{WIDR}		-	7.7	-	ns	
Rcvr Channel-to-channel Skew (Note 7)			-	<1	-	ns	
DIGITAL INPUTS							
Differential Input High Voltage	V_{DIFFH}	$V_{DIG+} - V_{DIG-}$	200	-	-	mV	
Differential Input Low Voltage	V_{DIFFL}	$V_{DIG+} - V_{DIG-}$	-	-	-200	mV	
Input Current	I_{IN}	$V_{IN} = V_{CC}$ or V_{EE}	-50	0	50	nA	
Common Mode Input Voltage Range	V_{CM}	$V_{DIFFL} \geq V_{DIFFH} - 0.2V$			$V_{CC} - 5V$	V	
		$V_{DIFFH} \leq V_{DIFFL} + 0.2V$	$V_{EE} + 0.2V$	-	-	V	
POWER SUPPLIES, DRIVER/RECEIVER STATIC CONDITIONS $V_{EXT} = V_{EE}$, EXTERNAL LOGIC POWER OPTION NOT USED. (Notes 10, 11)							
Positive Supply Current	I_{CC}	$V_{CC} = V_H = 12V$, $V_{EE} = V_L = -3V$, $V_{EXT} = V_{EE}$, Outputs Unloaded	-	65	85	mA	
Negative Supply Current	I_{EE}	$V_{CC} = V_H = 12V$, $V_{EE} = V_L = -3V$, $V_{EXT} = V_{EE}$, Outputs Unloaded	-85	-65	-	mA	
V_{EXT} Supply Current	I_{EXT}	$V_{CC} = V_H = 12V$, $V_{EE} = V_L = -3V$, $V_{EXT} = V_{EE}$, Outputs Unloaded	-	<1	-	mA	
POWER SUPPLIES, DRIVER/RECEIVER STATIC CONDITIONS $V_{EXT} = V_{EE} + 5.5V$, EXTERNAL LOGIC POWER OPTION USED. (Notes 11, 12)							
Positive Supply Current	I_{CC}	$V_{CC} = V_H = 12V$, $V_{EE} = V_L = -3V$, $V_{EXT} = V_{EE}$ + 5.5V, Outputs Unloaded	-	35	50	mA	

Electrical Specifications Test Conditions: $V_{CC} = 12V$, $V_{EE} = -3V$, $V_H = 6V$, $V_L = 0V$, Comp-High = 5V, Comp-Low = 0V, $V_{5V} = V_{EE}$ and $\overline{LOWSWING} = V_{CC}$. (Continued)

PARAMETER	SYMBOL	TEST CONDITIONS	MIN	TYP	MAX	UNITS
Negative Supply Current	I_{EE}	$V_{CC} = V_H = 12V$, $V_{EE} = V_L = -3V$, $V_{EXT} = V_{EE} + 5.5V$, Outputs Unloaded	-50	-35	-	mA
V_{EXT} Supply Current	I_{EXT}	$V_{CC} = V_H = 12V$, $V_{EE} = V_L = -3V$, $V_{EXT} = V_{EE} + 5.5V$, Outputs Unloaded	-	25	40	mA

NOTES:

7. Lab characterization, room temp, Timing Parameters Matched Stimulus/Loads, Channel to Channel Skew < 500ps, 1ns Max by design.
8. Measured across 100pF/1k lump sum load + 15pF PCB/Scope Probe. Capacitor and Resistor Surface Mount/Stacked ~0.5inch from Pin.
9. To Enable $\overline{LOWSWING}$, connect $\overline{LOWSWING}$ to V_{EE} and keep $V_H < V_{EE} + 5$. To disable $\overline{LOWSWING}$, connect it to V_{CC} .
10. When V_{EXT} is connected to V_{EE} (External Device Power not used) then the Minimum $V_{CC} - V_{EE}$ is 12V. When V_{EXT} is connected to an external 5.5V supply, then the minimum $V_{CC} - V_{EE}$ voltage is 9.0V. Recommended $V_{EXT} = 5.5V$ as referenced to V_{EE} .
11. I_{CC} and I_{EE} values are based on static conditions and will increase with pattern rates. I_{CC} and I_{EE} reach 400mA to 500mA at maximum data rates (provided sufficient device cooling is employed). These currents can be reduced by: Reducing the $V_{CC} - V_{EE}$ operating voltage or by Utilizing the V_{EXT} option.
12. When using $V_{EXT} = 5.5V$, current requirements of the V_{EXT} input can approach 100mA at maximum pattern rates.
13. Parameters with MIN and/or MAX limits are 100% tested at +25°C, unless otherwise specified. Temperature limits established by characterization and are not production tested.

Test Circuits and Waveforms

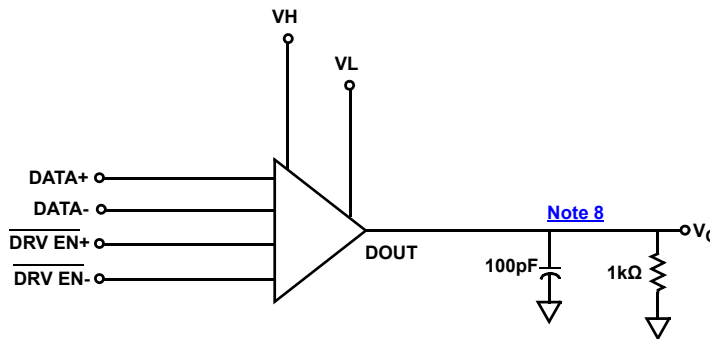

FIGURE 1. DRIVER SWITCHING TEST CIRCUIT

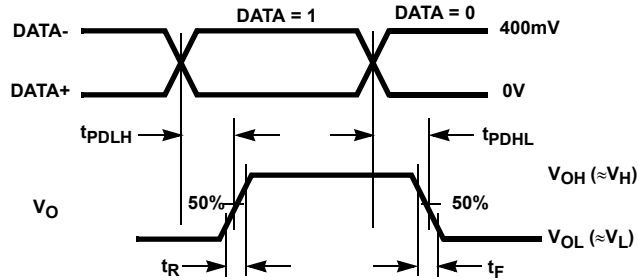

FIGURE 2. DRIVER PROPAGATION DELAY AND TRANSITION TIME MEASUREMENT POINTS

Test Circuits and Waveforms (Continued)

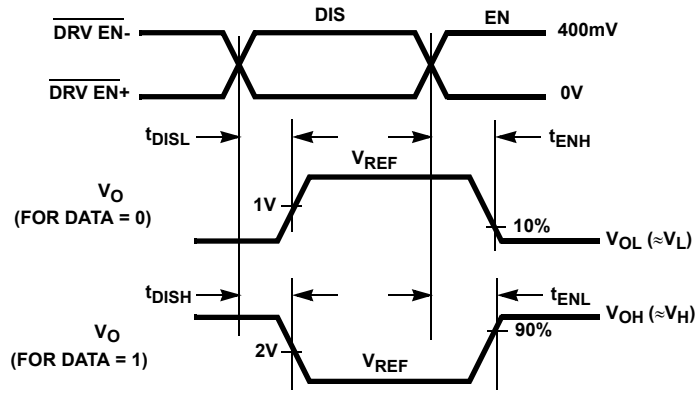

FIGURE 3. DRIVER ENABLE AND DISABLE TIME MEASUREMENT POINTS

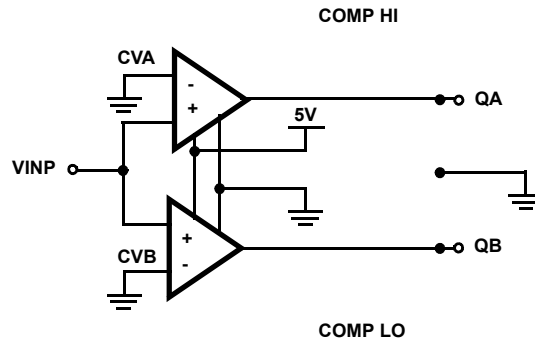

FIGURE 4. RECEIVER SWITCHING TEST CIRCUIT

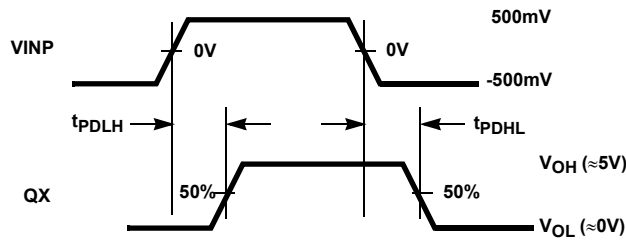

FIGURE 5. RECEIVER PROPAGATION DELAY MEASUREMENT POINTS

Application Information

The ISL55100A provides Quad pin drivers and Quad dual level comparator receivers in a small footprint. The four channels may be used as bidirectional or split channels. Drivers have per channel level, data and high impedance controls, while comparators have per channel high and low threshold levels.

Receiver Features

The receivers are four independent window comparators that feature high output current capability, and user defined high and low output levels to interface with a wide variety of logic families. Each receiver, comprises two comparators and each comparator has an independent threshold level input, making it easy to implement window comparator functions. The CVA and CVB pins set the threshold levels of the A and B comparators respectively. COMP HIGH and COMP LOW set all the comparator output levels, and COMP HIGH must be more positive than COMP LOW. These two inputs are unbuffered supply pins, so the sources driving these pins must provide adequate current for the expected load. COMP HIGH and COMP LOW typically connect to the power supplies of the logic device driven by the comparator outputs. The "Truth Table" for Receivers is on [page 3](#). Receiver outputs are not tri-statable, and do not incorporate any on-chip short-circuit current protection. Momentary short circuits to GND, or any supply voltage, won't cause permanent damage, but care must be taken to avoid longer duration short circuits. If tolerable to the application, current limiting resistors can be inserted in series with the QA(0 to 3) and QB(0 to 3) Outputs to protect the receiver outputs from damage due to overcurrent conditions.

Driver Features

The drivers are single-ended outputs featuring a wide voltage range, an output stage capable of delivering 200mA while providing a low out resistance and tri-state capability. Additionally, the driver output can be toggled to drive one of two user defined output levels High (VH) or Low (VL).

Driver waveforms are greatly affected by load characteristics. The ISL55100A actually double bonds the VH(0 to 3) and VL(0 to 3) supply pins for each channel. The Driver Output Pins (DOUT(0 to 3)) are triple bonded. Multiple bond wires help reduce the effects of Inductance between the IC Die (Wafer) and the packaging. Also the QFN style of packaging reduces inductance over other types of packaging.

While the inductance of a bond wire might seem insignificant, it can reduce high-frequency waveform fidelity. Therefore, this should be borne in mind when doing PCB layout and DUT interconnect. Lead lengths should be kept as short as possible, maintaining as much decoupling on the drive rails as possible and make sure scope measurements are made properly. Often the inductance of a scope probe ground can be the actual cause of the waveform distortion.

VH and VL (Driver Output Rails)

There are sets of VH and VL pins designated for each driver. These are unbuffered analog inputs that determine the Drive High (VH) and Drive Low (VL) Voltages that the drivers will

deliver. These inputs are double bonded to reduce inductance and decrease AC Impedance.

Each VH and VL should be decoupled with 4.7 μ F and 0.1 μ F capacitors to ground. If all four VH/VLs are bussed per device then one 4.7 μ F can be used for multiple VH/VL pins. Layouts should also accommodate the placement of capacitance "across" VH and VL. So in addition to decoupling the VH/VL pins to ground, they are also decoupled to each other.

Logic Inputs

The ISL55100A uses differential mode digital inputs, and can therefore mate directly with LVDS or CML outputs. Single-ended logic families are handled by connecting one of the digital input pins to an appropriate threshold voltage (e.g., 1.4V for TTL compatibility).

LOWSWING Circuit Option

The drivers include switchable circuitry that is optimized for either low (VH - VL < 3V) or high output swings, and this selection is accomplished via the LOWSWING pin. Connecting LOWSWING to VEE selects the circuits optimized for low overshoots at low swings, while tying the pin VCC enables the large signal circuitry (see [Figure 7](#)).

With LOWSWING = VEE, the low swing circuitry activates whenever VH < VEE + 5V, and the VH and VL currents increase, so for the lowest power dissipation set LOWSWING = VEE only if the output swing (VH - VL) is less than 3V, and better than 10% overshoots are required.

For the best small signal performance, the VH/VL common mode voltage [(VH + VL)/2] must be VEE + 1.5V. So if VEE = 0V, and the desired swing is 500mV, set VH = 1.75V, and VL = 1.25V.

Driver and Receiver Overload Protection

The ISL55100A is designed to provide minimum and balanced Driver R_{OUT}. Great care should be taken when making use of the ISL55100A low R_{OUT} drivers as there is no internal protection. There is no short-circuit protection built into either the driver or the receiver/comparator outputs. Also there are no junction temperature monitors or thermal shutdown features.

The driver or receiver outputs may be damaged by more than a momentary short-circuit directly to any low impedance voltage. If included, a 50 Ω Series Termination Resistor provides suitable driver protection, but should be properly rated.

External Logic Supply Option (V_{EXT})

Connection of the V_{EXT} Pin to a 5.5V DC Source (Referenced to VEE) will reduce the VCC - VEE current drain. Current drain is directly proportional to Data Rate. This option will help with Power Supply/Dissipation should heat distribution become an issue.

Power Supply Bypassing and Printed Circuit Board Layout

As with any high frequency device, good printed circuit board layout is necessary for optimum performance. Ground plane

construction is highly recommended, lead lengths should be as short as possible, and the power supply pins must be well bypassed to reduce the risk of oscillation. For normal single supply operation, where the VEE pin is connected to ground, one 0.1µF ceramic capacitor should be placed from the VCC pin to ground. A 4.7µF tantalum capacitor should then be connected from the VCC pin to ground. This same capacitor combination should be placed at each supply pin to ground if split supplies are to be used.

Power Dissipation Considerations

Specifying continuous data rates, driver loads and driver level amplitudes are key in determining power supply requirements as well as dissipation/cooling necessities. Driver Output patterns also impact these needs. The faster the pin activity, the greater the need to supply current and remove heat.

[Figures 17](#) and [18](#) address power consumption relative to Frequency of Operation. These graphs are based on Driving 6.0/0.0V Out into a 1kΩ Load. T_{JA} for the device package is 23.0°C/W, 16.6°C/W and 14.9°C/W based on airflows of 0m/s, 1m/s and 2.5m/s. The device is mounted per [Note 4](#) under [“Thermal Information” on page 4](#). With the high speed data rate capability of the ISL55100A, it is possible to exceed the +150°C “absolute maximum junction temperature” as operating conditions and frequencies increase. Therefore, it is important to calculate the maximum junction temperature for the application to determine if operating conditions need to be modified for the device to remain in the safe operating area.

The maximum power dissipation allowed in a package is determined according to [Equation 1](#):

$$P_{DMAX} = \frac{T_{JMAX} - T_{AMAX}}{\theta_{JA}} \quad (\text{EQ. 1})$$

where:

- T_{JMAX} = Maximum junction temperature
- T_{AMAX} = Maximum ambient temperature
- θ_{JA} = Thermal resistance of the package
- P_{DMAX} = Maximum power dissipation in the package

The maximum power dissipation actually produced by an IC is the total quiescent supply current times the total power supply voltage, plus the power in the IC due to the loads. Power also depends on the number of channels changing state, and the frequency of operation. The extent of continuous active pattern generation/reception will greatly effect dissipation requirements.

The power dissipation curves ([Figure 17](#)), provide a way to see if the device will overheat. The junction temperature rise above ambient vs. operating frequency can be found graphically in [Figure 18](#). This graph is based on the package type T_{JA} ratings and actual current/wattage requirements of the ISL55100A when driving a 1k load with a 6V High Level and a 0V Low Rail. The temperatures are indicated as calculated junction temperature over the ambient temperature of the user's system. Plots indicate temperature change as operating frequency increases (the graph assumes continuous operation). The user should evaluate various heat sink/cooling

options in order to control the ambient temperature part of the equation. This is especially true if the user's applications require continuous, high speed operation.

The reader is cautioned against assuming the same level of thermal performance in actual applications. A careful inspection of conditions in your application should be conducted. Great care must be taken to ensure Die Temperature does not exceed Absolute Maximum Thermal Limits.

Important Note: The ISL55100A package metal pad (EP) is used for heat sinking of the device. It is electrically connected to the negative supply potential (VEE). If VEE is tied to ground, the thermal pad can be connected to ground. Otherwise, the thermal pad (VEE) must be isolated from other power planes.

Power Supply Sequencing

The ISL55100A references every supply with respect to VEE. Therefore apply VEE, then VCC followed by the VH, VL busses, then the COMP High and Comp Low followed by the CVA and CVB Supplies. Digital Inputs should be set with a differential bias as soon as possible. In cases where VEXT is being utilized ($V_{EXT} = V_{EE} + 5.5V$), it should be powered up immediately after VCC. Basically, no pin should be biased above VCC or below VEE.

Data Rates

Please note that the Frequency (MHz) in [Figures 17](#) and [18](#) contain two transitions within each period. A digital application that requires a new test pattern every 50ns would be running at a 20MHz Data Rate. [Figure 19](#) reveals that a 100ns period, 10MHz in frequency parlance, results in two 50ns digital patterns.

ESD Protection

[Figure 6](#) is the block diagram depicting the ESD protection networks. The DOUT-to-VH diode is the upper FET's drain-to-body diode.

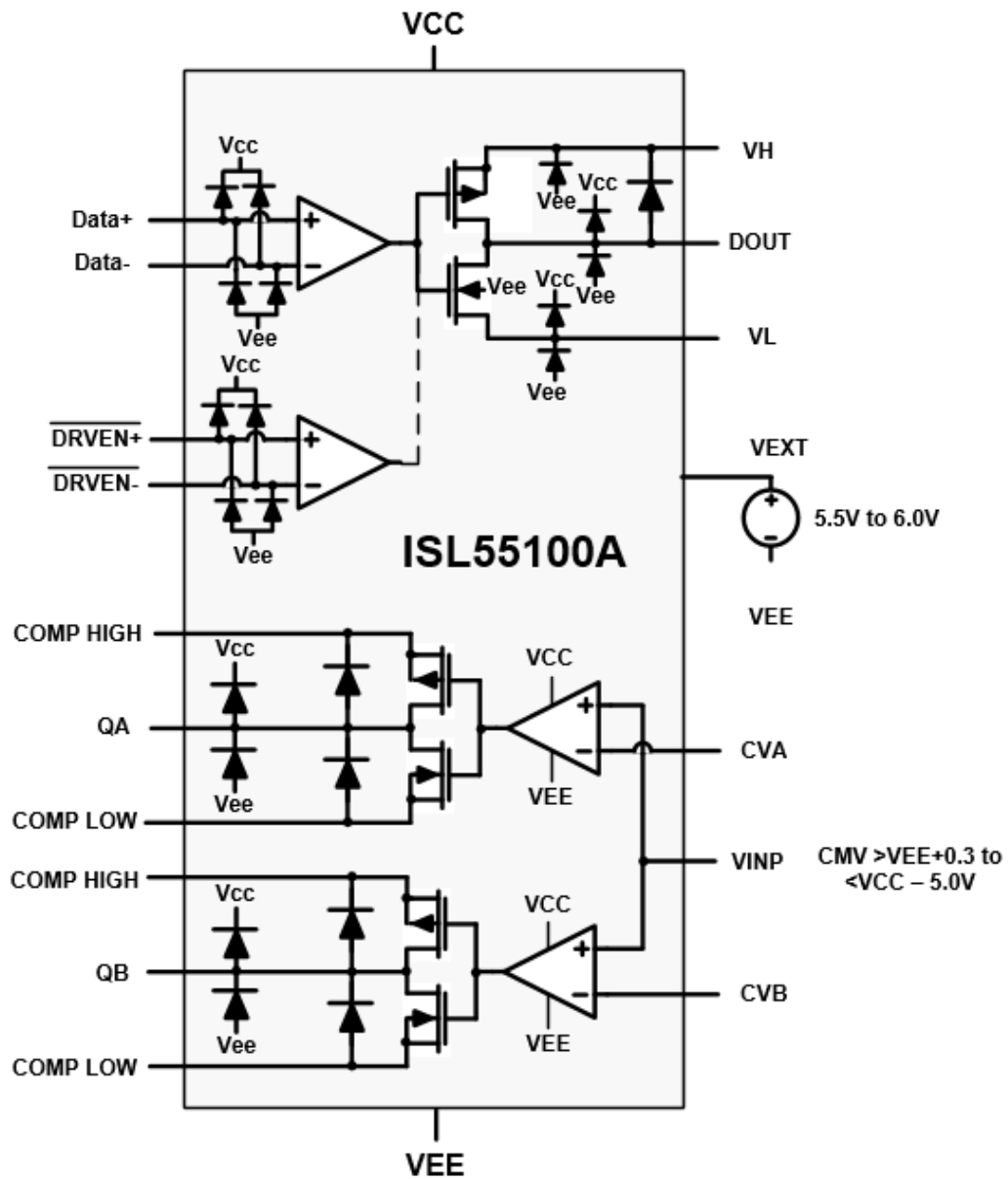

FIGURE 6. ESD STRUCTURE BLOCK DIAGRAM

Typical Performance Curves Device installed on Intersil ISL55100A Evaluation Board.

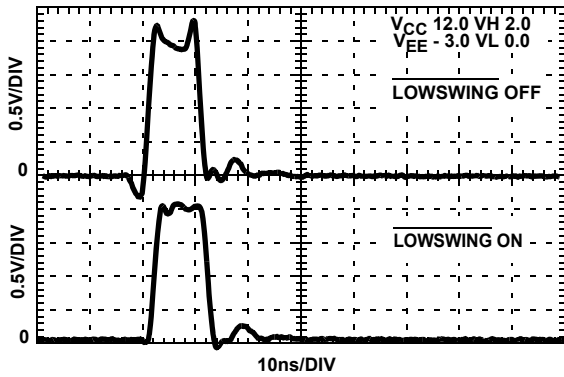

FIGURE 7. LOWSWING EFFECTS ON DRIVER SHAPE AND t_{PD} (100pF-1k LOAD)

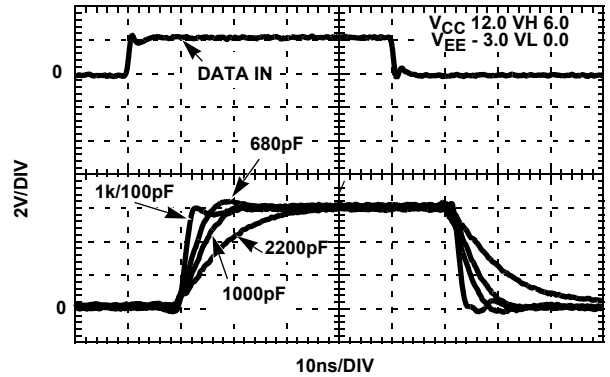

FIGURE 8. DRIVER WAVEFORMS UNDER VARIOUS LOADS

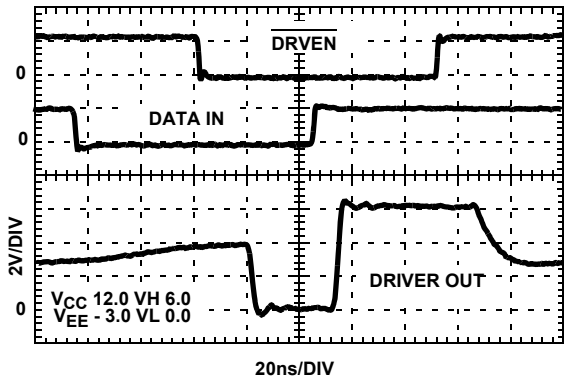

FIGURE 9. DATA/HIZ/DRIVER OUT TIMING

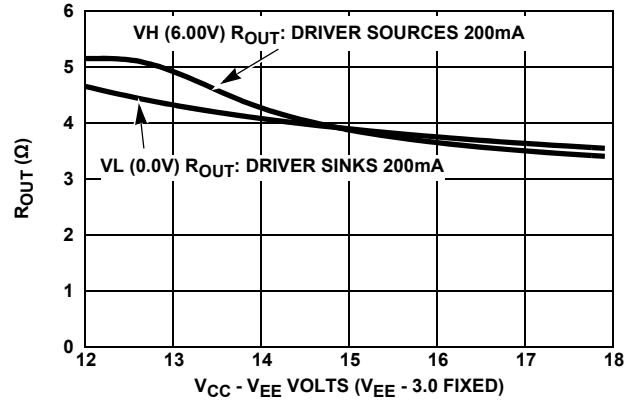

FIGURE 10. R_{OUT} vs DEVICE VOLTAGE

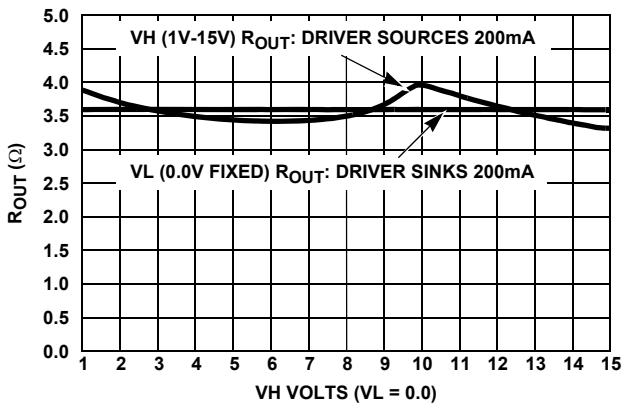

FIGURE 11. R_{OUT} vs VH RAIL

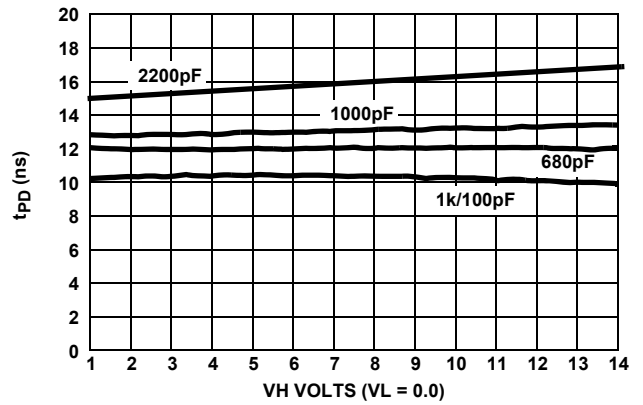

FIGURE 12. PROPAGATION DELAY vs VH RAIL, VARIOUS LOADS

Typical Performance Curves Device installed on Intersil ISL55100A Evaluation Board. (Continued)

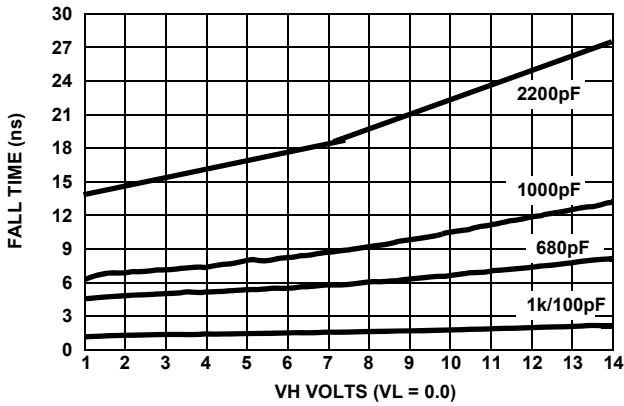

FIGURE 13. DRIVER FALL TIME vs VH RAIL, VARIOUS LOADS

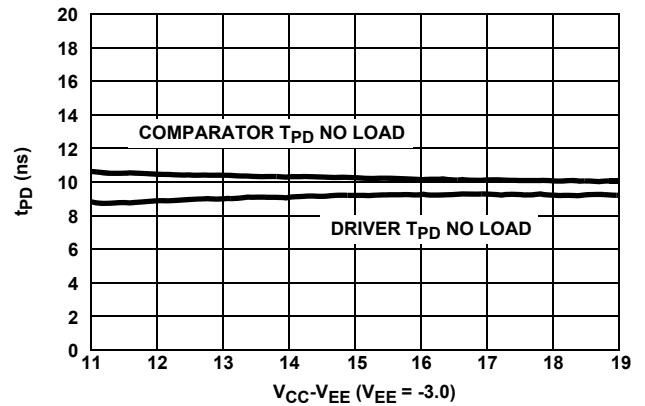

FIGURE 14. DRIVER AND RECEIVER TPD VARIANCE vs VCC

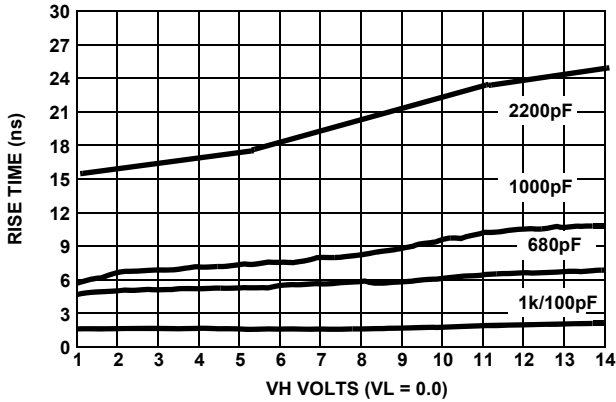

FIGURE 15. DRIVER RISE TIME vs VH RAIL, VARIOUS LOADS

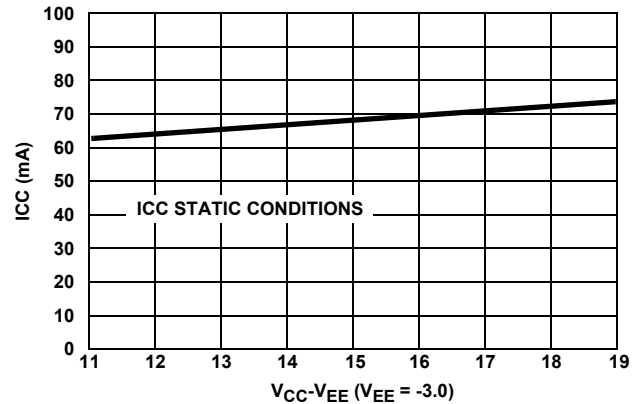

FIGURE 16. STATIC ICC vs VCC

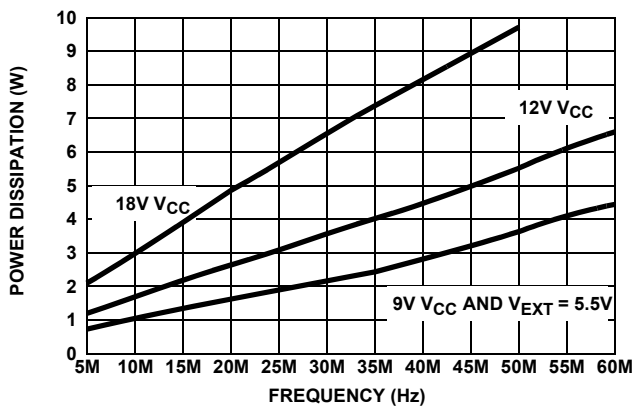

FIGURE 17. DEVICE POWER DISSIPATION WITH $V_{CC} - V_{EE} = 18, 12$ AND 9.0 ($V_{EXT} = 5.5V$) VOLTS. ALL FOUR PINS MAKING TWO TRANSITIONS PER PERIOD

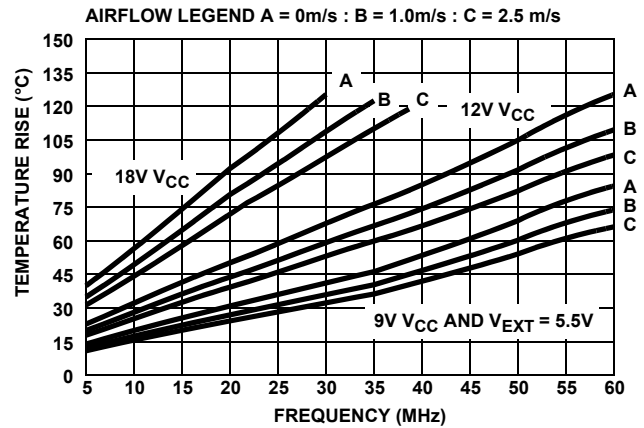

FIGURE 18. CALCULATED JUNCTION TEMP ABOVE AMBIENT WITH $V_{CC} - V_{EE} = 18, 12$ AND 9.0 ($V_{EXT} = 5.5V$) VOLTS. ALL FOUR PINS MAKING TWO TRANSITIONS PER PERIOD.

Typical Performance Curves

Device installed on Intersil ISL55100A Evaluation Board. (Continued)

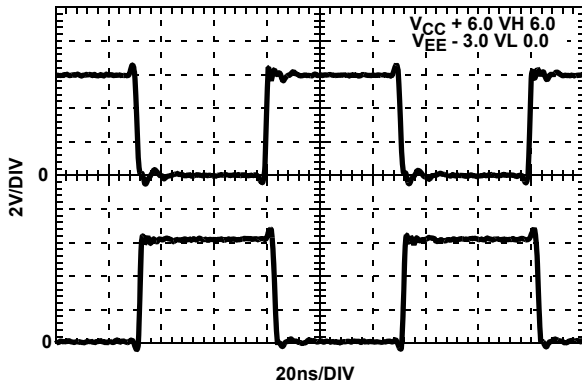

FIGURE 19. FREQUENCY OF 10MHz = 50ns PATTERN RATE

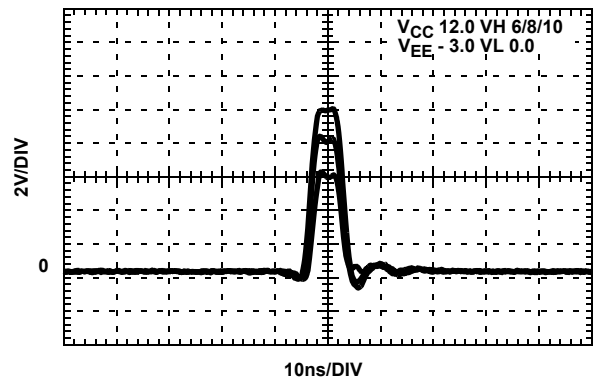

FIGURE 20. MINIMUM PULSE WIDTH VH 6/8/10V

Revision History

The revision history provided is for informational purposes only and is believed to be accurate, but not warranted. Please go to the web to make sure that you have the latest revision.

DATE	REVISION	CHANGE
December 4, 2014	FN7489.3	<p>Update the datasheet throughout to Intersil's new standard.</p> <p>On page 2, updated the ordering information by adding MSL note.</p> <p>On page 3, in "Pin Descriptions" table, added "This is also the potential of the exposed thermal pad on the package bottom." to the VEE row. Added "EP" row.</p> <p>On page 4, under "Absolute Maximum Ratings" changed "DOUT" range from "VL - 0.5V" to "VEE - 0.5V".</p> <p>On page 9, changed a sentence in the 5th paragraph from "The maximum safe power temperature vs operating frequency can be found graphically in Figure 18." to "The junction temperature rise above ambient vs. operating frequency can be found graphically in Figure 18."</p> <p>On page 9, edited "ESD Protection" paragraph.</p> <p>On page 10, revised Figure 6 to represent actual ESD structures.</p> <p>On page 12, changed the Y-axis label from "Temperature" to "Temperature Rise".</p> <p>Added Revision History and About Intersil sections.</p>

About Intersil

Intersil Corporation is a leading provider of innovative power management and precision analog solutions. The company's products address some of the largest markets within the industrial and infrastructure, mobile computing and high-end consumer markets.

For the most updated datasheet, application notes, related documentation and related parts, please see the respective product information page found at www.intersil.com.

You may report errors or suggestions for improving this datasheet by visiting www.intersil.com/ask.

Reliability reports are also available from our website at www.intersil.com/support

© Copyright Intersil Americas LLC 2005-2014. All Rights Reserved.

All trademarks and registered trademarks are the property of their respective owners.

For additional products, see www.intersil.com/en/products.html

Intersil products are manufactured, assembled and tested utilizing ISO9001 quality systems as noted in the quality certifications found at www.intersil.com/en/support/qualandreliability.html

Intersil products are sold by description only. Intersil may modify the circuit design and/or specifications of products at any time without notice, provided that such modification does not, in Intersil's sole judgment, affect the form, fit or function of the product. Accordingly, the reader is cautioned to verify that datasheets are current before placing orders. Information furnished by Intersil is believed to be accurate and reliable. However, no responsibility is assumed by Intersil or its subsidiaries for its use; nor for any infringements of patents or other rights of third parties which may result from its use. No license is granted by implication or otherwise under any patent or patent rights of Intersil or its subsidiaries.

For information regarding Intersil Corporation and its products, see www.intersil.com

Quad Flat No-Lead Plastic Package (QFN)
Micro Lead Frame Plastic Package (MLFP)

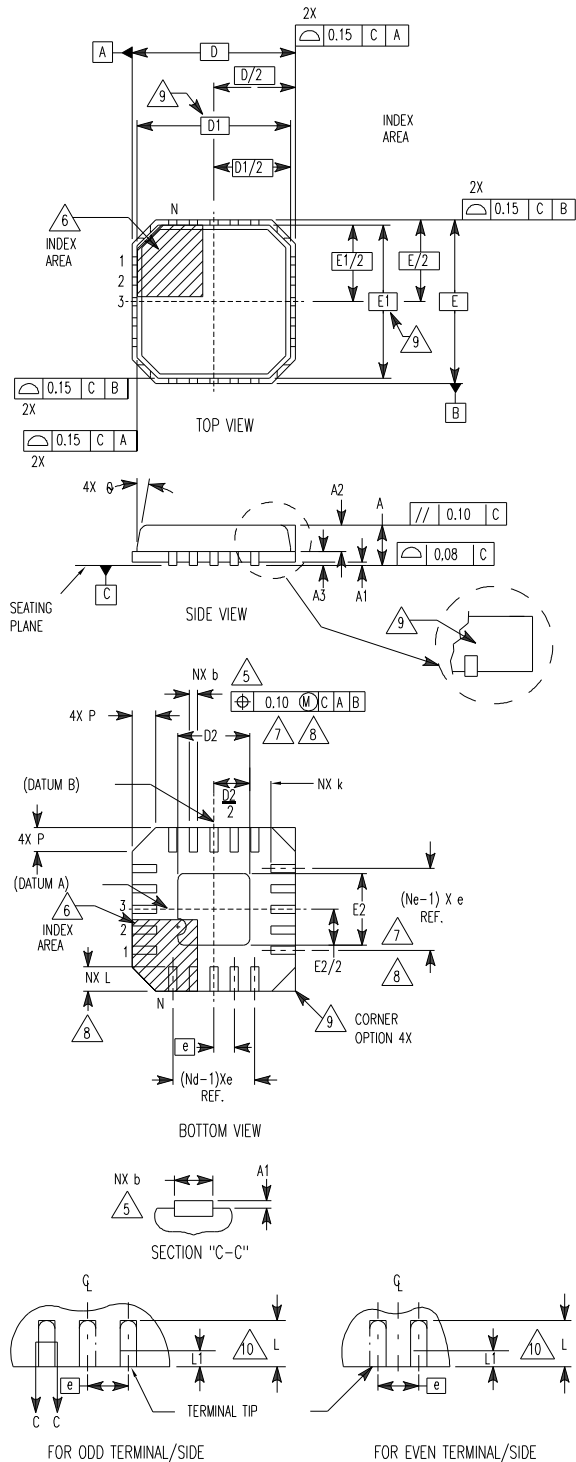

L72.10x10
72 LEAD QUAD FLAT NO-LEAD PLASTIC PACKAGE

SYMBOL	MILLIMETERS			NOTES
	MIN	NOMINAL	MAX	
A	0.80	0.90	1.00	-
A1	-	0.02	0.05	-
A2	-	0.65	1.00	9
A3	0.20 REF			9
b	0.18	0.25	0.30	5, 8
D	10.00 BSC			-
D1	9.75 BSC			9
D2	5.85	6.00	6.15	7, 8
E	10.00 BSC			-
E1	9.75 BSC			9
E2	5.85	6.00	6.15	7, 8
e	0.50 BSC			-
k	0.20	-	-	-
L	0.30	0.40	0.50	8, 10
N	72			2
Nd	18			3
Ne	18			3
P	-	-	0.60	9
θ	-	-	12	9

Rev. 1 11/04

NOTES:

1. Dimensioning and tolerancing conform to ASME Y14.5-1994.
2. N is the number of terminals.
3. Nd and Ne refer to the number of terminals on each D and E.
4. All dimensions are in millimeters. Angles are in degrees.
5. Dimension b applies to the metallized terminal and is measured between 0.15mm and 0.30mm from the terminal tip.
6. The configuration of the pin #1 identifier is optional, but must be located within the zone indicated. The pin #1 identifier may be either a mold or mark feature.
7. Dimensions D2 and E2 are for the exposed pads which provide improved electrical and thermal performance.
8. Nominal dimensions are provided to assist with PCB Land Pattern Design efforts, see Intersil Technical Brief TB389.
9. Features and dimensions A2, A3, D1, E1, P & θ are present when Anvil singulation method is used and not present for saw singulation.
10. Compliant to JEDEC MO-220VND-3 except for the "L" min dimension.