

OPTICAL ENCODERS

RE20F

FEATURES

- Compact, dia.: 20 mm
- Low torque, low inertia
- RoHS compliant

RoHS compliant



PART NUMBER DESIGNATION

RE20F - 100 - 100

Series name

Resolution (P/R)

100, 300

Output phase

1 : "A" only
2 : "A" & "B" (100 P/R only)

LIST OF PART NUMBERS

Resolution	Item	Output phases	Part number
100 (P/R)		"A" only	RE20F-100-100
300 (P/R)			RE20F-300-100
100 (P/R)		"A" & "B"	RE20F-100-200

※ Verify the above part numbers when placing orders.

STANDARD SPECIFICATIONS

Electrical characteristics

Item	Output phases	"A" only	"A" & "B"
Photo-sensor maximum current		45 mA maximum (at 25 °C)	
Output wave form		Quasi-sinusoidal	
Output phases		A	A, B
Resolution		100, 300	100
Phase difference of outputs A & B		—	90° ± 45°
Maximum frequency response		—	12 kHz
Output signal		150 mVp-p minimum ※1	1 Vp-p minimum
Output signal amplitude variation ※2		40 % maximum	
Light source		LED	

※ 1 Measured at CP1 in the fig.A of 'MEASUREMENT CIRCUIT' on the following page.

※ 2 One phase only : Measured at CP2 in the fig.A of 'MEASUREMENT CIRCUIT' on the following page.

Mechanical characteristics

Starting torque	0.05 mN·m {0.5 gf·cm} maximum	
Inertia	0.2 g·cm ² maximum	
Shaft loading (When mounting)	Radial	1.96 N {200 gf} maximum
	Axial	4.9 N {500 gf} maximum
Net weight	Approx. 15 g	

Environmental characteristics

Operating temp. range	0 ~ 50 °C
Storage temp. range	- 20 ~ 80 °C
Protection grade	IP40

RE20F

OPTICAL ENCODERS

RELIABILITY TEST

The output wave form and starting torque shall satisfy the STANDARD SPECIFICATIONS after the following tests.

Test item		Test conditions	
Vibration	Power OFF	Amplitude : 1.52 mm or 98.1 m/s ² (10 G) whichever is smaller. 10 ~ 500 Hz excursion 5 min/cycle, 1 hour each for X, Y, Z, directions.	
Shock	Power OFF	1 time each in 6 directions (X, Y, Z) at 490 m/s ² (50 G), 11 ms.	
High temperature exposure	Power OFF	80 °C 96 h	(To be measured after leaving samples for 1 h at normal temperature and humidity after the test.)
	Power ON	50 °C 96 h	
Low temperature exposure	Power OFF	- 20 °C 96 h	
	Power ON	0 °C 96 h	
Humidity	Power OFF	(To be measured after wiping out moisture and leaving samples for 1 h at normal temperature and humidity after the test.)	
Thermal shock	Power OFF	To be done 10 cycles with the following condition (To be measured after leaving samples for 1 h at normal temperature and humidity after the test.) 70 °C 1 h, - 20 °C 1 h	

OUTLINE DIMENSIONS

Unless otherwise specified, tolerance: ± 0.4 (Unit: mm)

RE20F

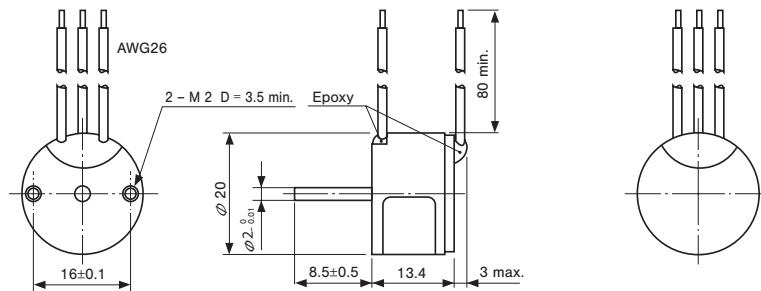

OUTPUT

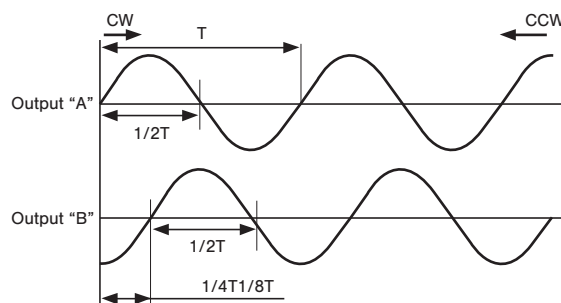

RE20F

OPTICAL ENCODERS

EXTERNAL SCHEMATICS

(2 phase) 100 P/R

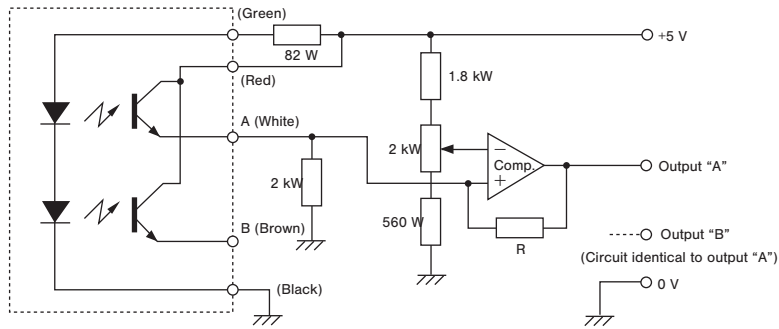

INTERNAL CIRCUIT

(1 phase) 100 • 300 P/R

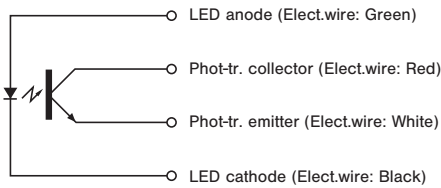

(2 phases) 100 P/R

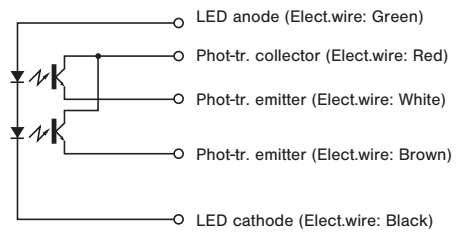

MEASUREMENT CIRCUIT

(1 phase) 100 • 300 P/R

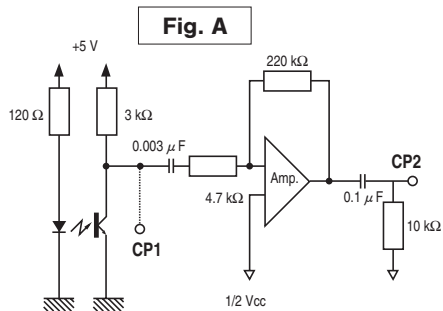

Frequency characteristics: 3 kHz (at constant speed)

(2 phases) 100 P/R

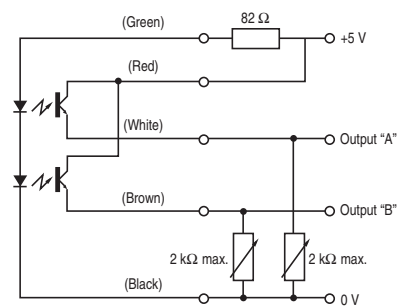

RATINGS

LED

(at 25 °C)

Maximum current	45 mA
Reverse voltage	4 V
Power dissipation (P _D)	75 mW
Temp. derating of P _D (25 ~ 60 °C)	-1.4 mW/°C

Photo-sensor

(at 25 °C)

Collector current	20 mA
Collector to emitter voltage (forward)	20 V
Collector to emitter voltage (reverse)	5 V
Collector dissipation (P _D)	75 mW
Temp. derating of P _D (25 ~ 60 °C)	-1.0 mW/°C