

QT-Brightek High Power Series

1.0 W High Power IR LED

Part No.: QBHP684-IR4XU

U = 350mA

4 = 740nm

X = Viewing Angle (X=A:60° ; X=B:120°)

Table of Contents:

Introduction	3
Electrical / Optical Characteristic (Ta=25 °C)	4
Absolute Maximum Rating	4
Characteristic Curves.....	5
IR Reflow Soldering Profile	7
Packing	8
Labeling	9
Ordering Information	9
Revision History	10
Disclaimer	10

Introduction

Feature:

- 1W High Bright IR LED
- Packed in tape and reel
- High radiant power output
- Viewing Angle 60° typ. (QBHP684-IR4AU)
- Viewing Angle 120° typ. (QBHP684-IR4BU)
- Isolated Heat Slug

Description:

This 1W high power IR LED has compact size of 3.5 x 3.5mm. It is ideal for both infrared sensing applications.

Application:

- Data transmission
- Sensing
- Remote control

Certification & Compliance:

- TS16949
- ISO9001
- RoHS Compliant



Outline Dimensions:

60°

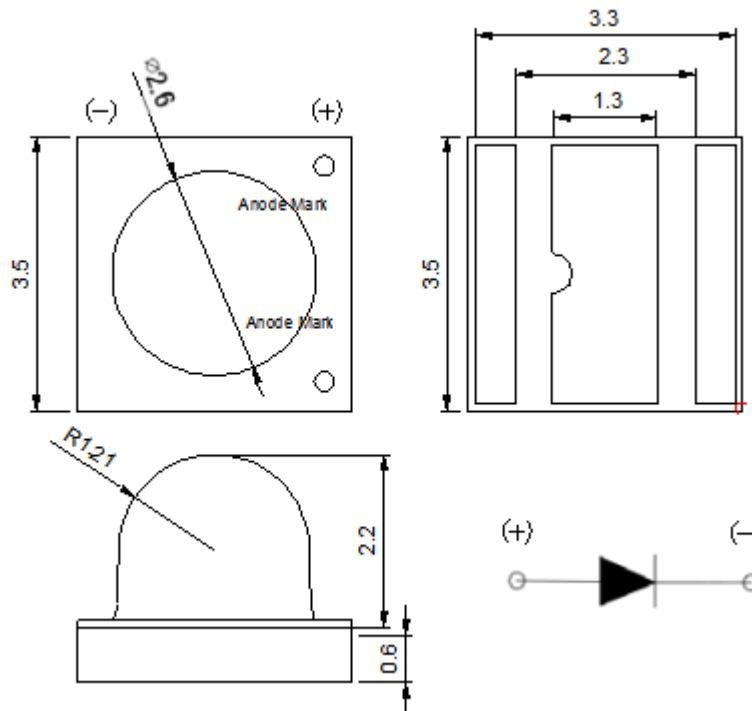

120°

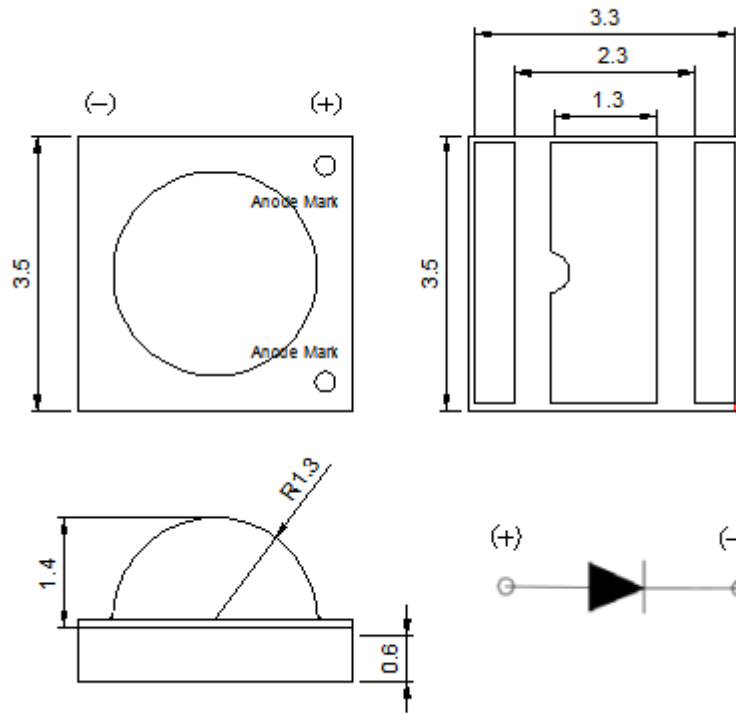

Units: mm / tolerance = +/-0.2mm

Electrical / Optical Characteristic (Ta=25 °C)

Product Number	Color	I _F (mA)	V _F (V)			λ _p (nm)			P _O (mW)	
			Min.	Typ.	Max.	Min.	Typ.	Max.	Min.	Typ.
QBHP684-IR4AU	Infrared	350	1.4	1.9	2.4	730	740	750	250	320
QBHP684-IR4BU										

Absolute Maximum Rating

P _d (W)	I _F (mA)	I _{FP} (mA)	V _R (V)	T _{OP} (°C)	T _{ST} (°C)	T _{SOL} (°C)
1.68	700	1000	5	-40 to +85	-40 to +100	260

Radiometric Power P_O @ I_F=350mA

Bin	Min.	Max.	Unit
P30	250	300	mW
P35	300	350	
P40	350	400	

Characteristic Curves

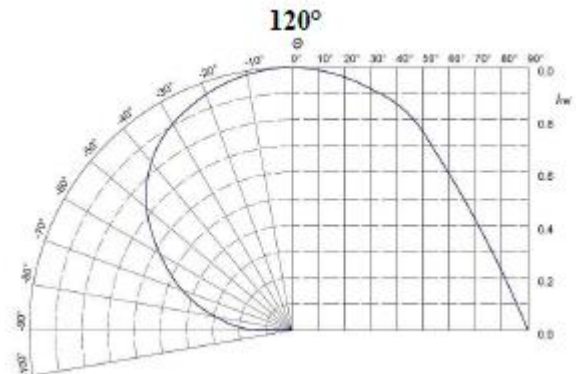
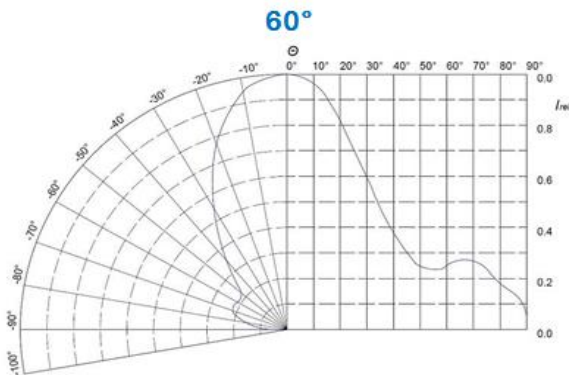
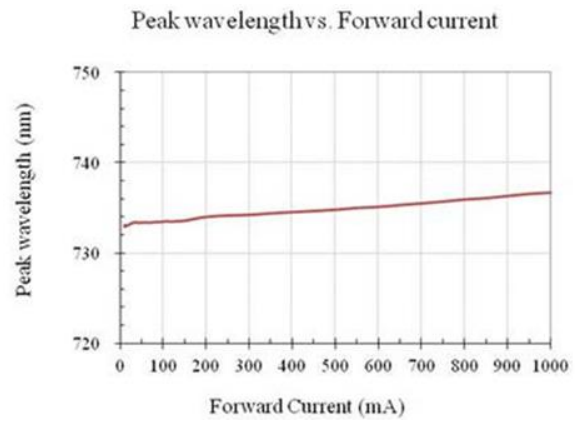
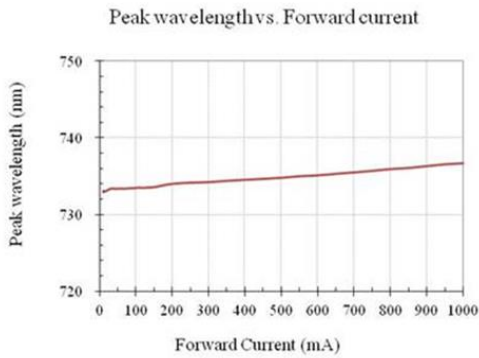
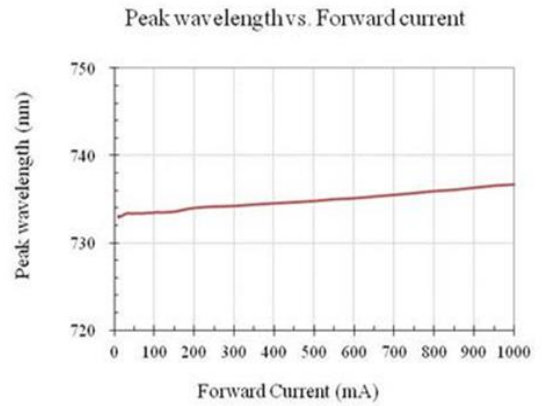
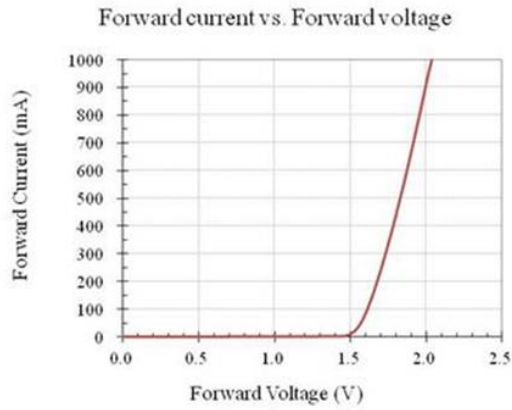

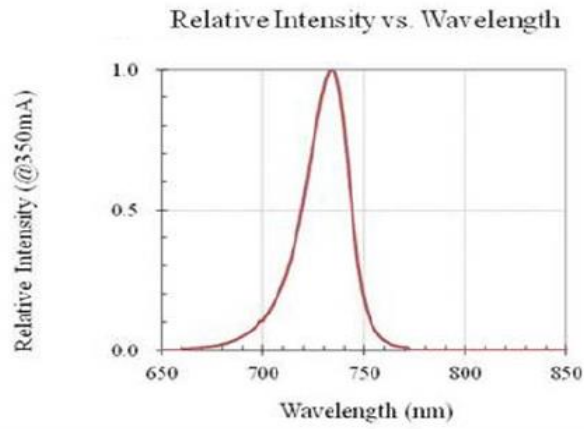

IR Reflow Soldering Profile

Lead Free solder

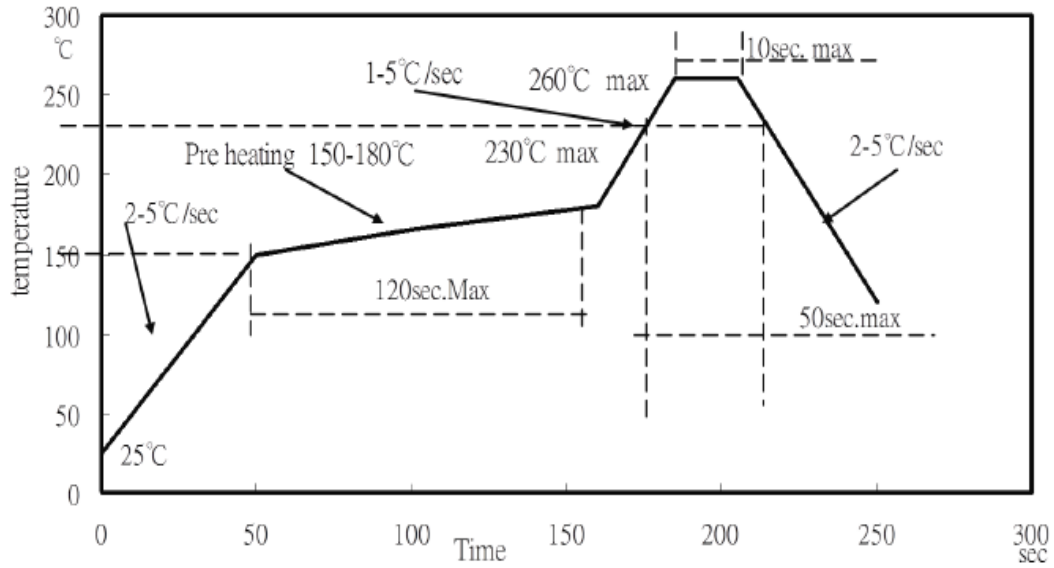

Recommended Soldering Pad:

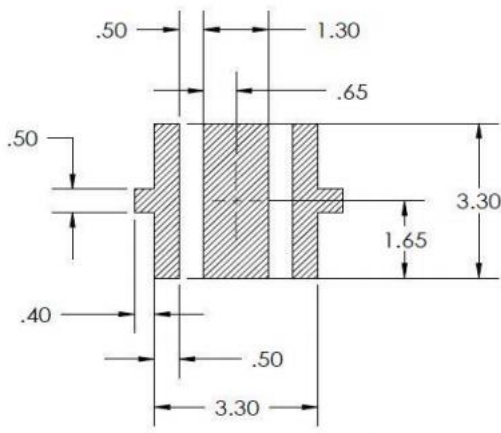

RECOMMENDED PCB SOLDER PAD

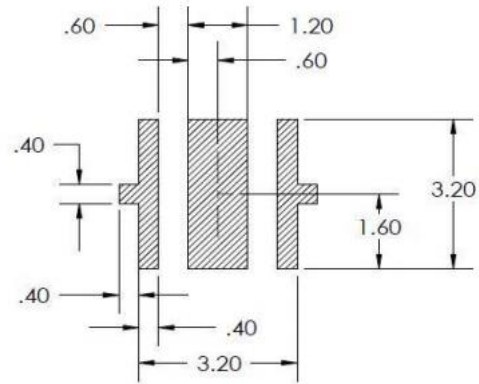

RECOMMENDED STENCIL PATTERN
(HATCHED AREA IS OPENING)

Unit: mm

Packing

Tape and Reel:

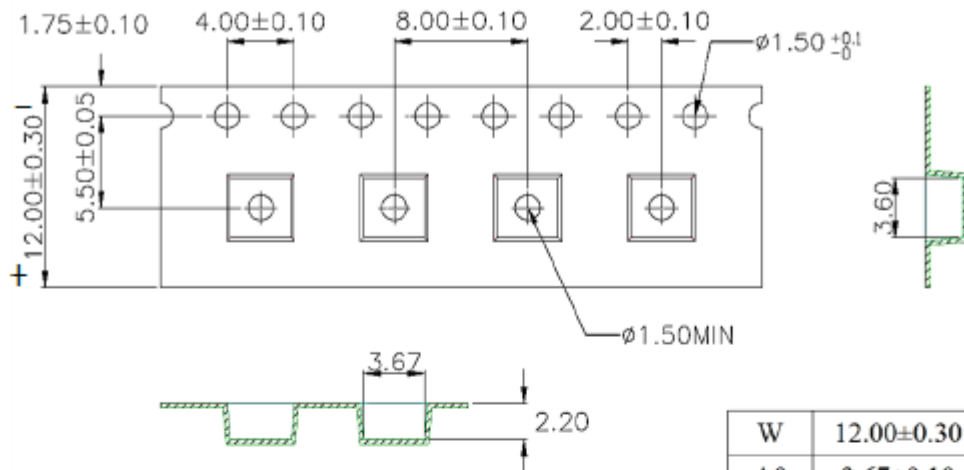

1. 10 sprocket hole pitch cumulative tolerance ± 0.20 .
2. Carrier camber is within 1 mm in 250 mm.
3. Material : Black Conductive Polystyrene Alloy.
4. All dimensions meet EIA-481-D requirements.
5. Thickness : 0.30 ± 0.05 mm.

W	12.00±0.30
A0	3.67±0.10
B0	3.60±0.10
K0	2.20±0.10

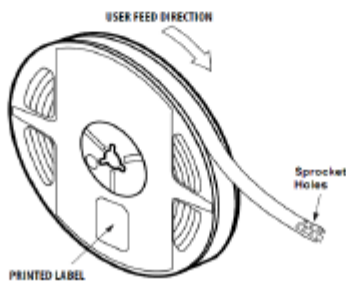
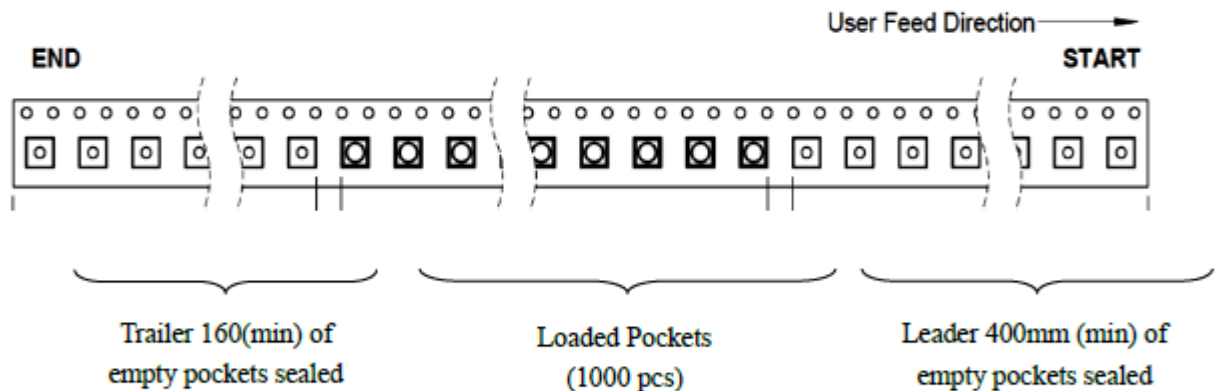

Unit: mm

Labeling

Part No: _____

Customer P/N: _____

Item: _____

Q'ty: _____

Vf: _____

Iv: _____

WI: _____

Date: _____

Made in Taiwan**Ordering Information**

Part #	Orderable Part #	Spec Range	Quantity per reel
QBHP684-IR4AU	QBHP684-IR4AU	Po=320mW typ. @ I _F =350mA, λ _P =730nm ~ 750nm, VA=60°	500
QBHP684-IR4BU	QBHP684-IR4BU	Po=320mW typ. @ I _F =350mA, λ _P =730nm ~ 750nm, VA=120°	1000

Revision History

Description:	Revision #	Revision Date
New Release of QBHP684-IR4XU	V1.0	02/19/2016
Fix part# and order part# typos at Ordering Information section	V1.1	02/29/2016
Correct the packing spec for QBHP684-IR4AU	V1.2	03/24/2016
Update drawing dimension	V1.3	09/08/2016
Update brightness	V1.4	08/04/2021

Disclaimer

QT-BRIGHTEK reserves the right to make changes without further notice to any products herein to improve reliability, function or design. QT-BRIGHTEK does not assume any liability arising out of the application or use of any product or circuit described herein; neither does it convey any license under its patent rights, nor the rights of others.

Life Support Policy

QT-BRIGHTEK's products are not authorized for use as critical components in life support devices or systems without the express written approval of QT-BRIGHTEK. As used herein:

1. Life support devices or systems are devices or systems which, (a) are intended for surgical implant into the body, or (b) support or sustain life, and (c) whose failure to perform when properly used in accordance with instructions for use provided in the labeling, can be reasonably expected to result in a significant injury of the user.
2. A critical component in any component of a life support device or system whose failure to perform can be reasonably expected to cause the failure of the life support device or system, or to affect its safety or effectiveness.