

GP - GLANDPLATES

BUL10293
REV. B

ASSEMBLY INSTRUCTIONS FOR GLANDPLATE ACCESSORIES

INSTRUCTIONS :

- A) Locate glandplate in desired location on enclosure.
- B) Use glandplate as template for marking hole and cutout location. Mark around outside of glandplate then offset 5/8" (16mm) and remark. (Use chart to confirm cutout size)
- C) Drill (1/4" / 6mm) holes and cut glandplate opening.
- D) Install gasket onto body of enclosure.
- E) Install glandplate with provided 10-32 hardware.

Torque screws to 5.4 Nm (4lbf/ft)

PART NUMBER	CUTOUT SIZE		NUMBER OF SCREWS
	H	W	
GP063	1.50	5.06	4
GP134	2.31	11.75	6
GP136	4.63	12.13	6
GP216	4.63	19.63	12

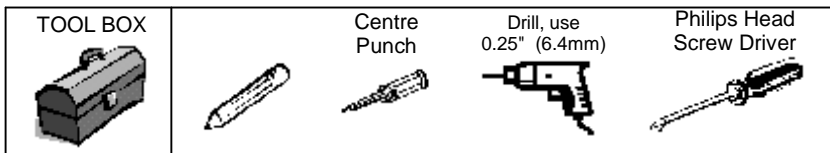
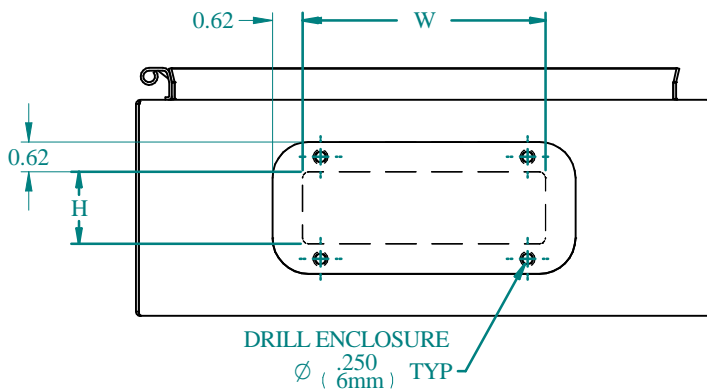
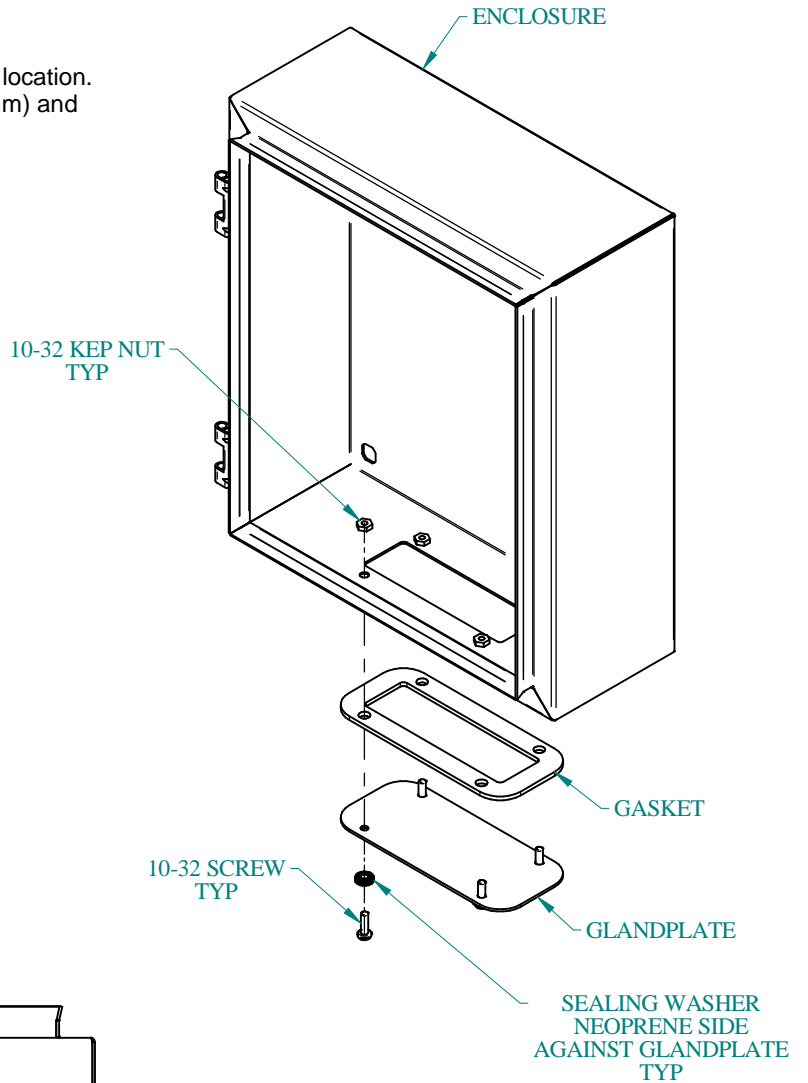

**HAMMOND
MANUFACTURING™
ENCLOSURES**